

HS21 SERIES UNITS

HS21 early model units (-411, -511, -651) and late model units (-036, -048, -060) are high efficiency residential split-system condensing units which features a two-speed compressor. Models are available in sizes ranging from 3 through 5 tons in either single or three-phase configuration. The series features solid-state two-speed control, which regulates compressor speed in response to thermostat demand. The HS21 is designed for use with an expansion valve at the indoor coil.

This manual is divided into sections which discuss the components, refrigerant system, charging procedures, maintenance and operation sequences.

Information contained in this manual is intended for use by Lennox service technicians only. All specifications are subject to change. Procedures outlined in this manual are presented as a recommendation only and do not supersede or replace local or state codes. In the absence of local or state codes, the guidelines and procedures outlined in this manual (except where noted) are recommended only.

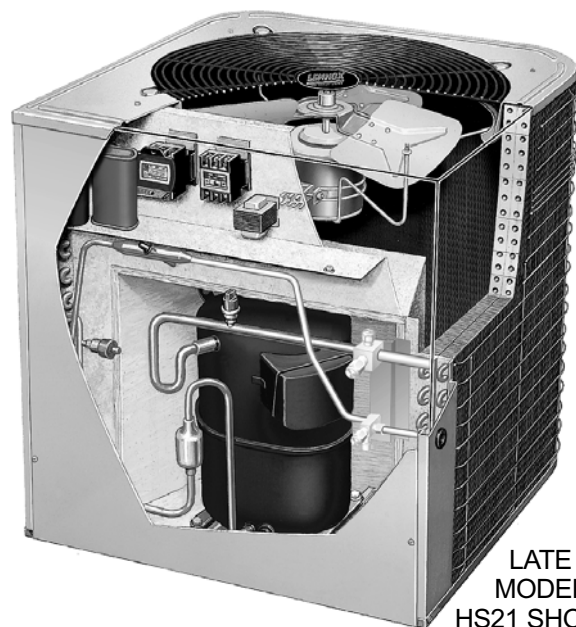

LATE
MODEL
HS21 SHOWN

SPECIFICATIONS (Early Model)

Model No.		HS21-411 HS21-413	HS21-511 HS21-513	HS21-651 HS21-653
Condenser Coil	Face area (sq.ft.)	21.64/	21.64/	23.92/
	outside / inside	20.81	20.81	23.01
	Tube diameter (in.)	3/8	3/8	3/8
	No. of Rows	2	2	2
Condenser Fan	Fins per inch	20	20	20
	Diameter (in.)	24	24	24
	No. of Blades	3	3	4
	Motor hp	1/6	1/6	1/4
	Cfm	3200	3200	4200
	Rpm	815	815	815
	Watts	170	170	310
Refrigerant Charge (HCFC-22)		11lbs. 6oz.	11lbs. 14oz.	13lbs. 14oz.
Liquid line connection (sweat)		3/8	3/8	3/8
Suction line connection (sweat)		7/8	7/8	1-1/8

ELECTRICAL DATA (Early Model)

Model No.		HS21-411	HS21-413	HS21-511	HS21-513	HS21-651	HS21-653
Line voltage data - 60hz.		208/230/1ph	208/230/3ph	208/230/1ph	208/230/3ph	208/230/1ph	208/230/3ph
Compressor	Rated load amps	17.6	12.7	21.6	15.8	30.8	19.9
	Power factor	.98	.90	.98	.90	.92	.90
	Locked rotor amps	90.0	60.0	120.0	85.0	141.0	91.0
Outdoor Coil Fan Motor	Full load amps	1.0	1.0	1.0	1.0	1.7	1.7
	Locked rotor amps	1.9	1.9	1.9	1.9	2.9	2.9
Max fuse or circuit breaker size (amps)		40	25	45	35	60	45
*Minimum circuit ampacity		23.0	16.9	28.0	20.8	40.2	26.6

*Refer to National Electrical Code Manual to determine wire, fuse and disconnect size requirements.

NOTE - Extremes of operating range are plus 10% and minus 5% of line voltage

SPECIFICATIONS (Late Models)

Model No.		HS21-036		HS21-048		HS21-060		
Nominal Tonnage		3		4		5		
Liquid line — in. (mm) o.d. connection (sweat)		3/8 (9.5)						
Suction line — in. (mm) o.d. connection (sweat)		7/8 (22.2)				1-1/8 (28.5)		
Condenser Coil	Net face area — sq. ft. (m ²)	Outer coil		21.77 (2.02)		24.06 (2.24)		
		Inner coil		21.11 (1.96)		23.33 (2.17)		
	Tube diameter — in. (mm) & no. of rows		5/16 (7.9) — 2					
	Fins per inch (m)		22 (866)					
Condenser Fan	Diameter — in. (mm) & no. of blades		24 (610) — 3			24 (610) — 4		
	Motor hp		1/6 (124)			1/4 (187)		
	Cfm (L/s)		3200 (1510)			4200 (1980)		
	Rpm		815					
	Watts		170			310		
*Refrigerant charge furnished (HCFC-22)		10 lbs. 10 oz. (4.80 kg)		11 lbs. 0 oz. (4.98 kg)		12 lbs. 4 oz. (5.55 kg)		
Shipping weight — lbs. (kg) 1 package		328 (149)		329 (149)		352 (160)		
OPTIONAL ACCESSORIES - MUST BE ORDERED EXTRA								
Mounting Base		MB2-L (69J07)						
Low Ambient Kit		LB-57113BC (24H77)						
Indoor Blower Speed Relay Kit		72G36						
CCB1 EfficiencyPlus™ Humidity Control		35H00						
EBR1 Blower Relay Kit		75H90						
Compressor Monitor (Canada Only)		T6-1469 (45F08)						

*Refrigerant charge is sufficient for 15 ft. (4.5 m) length line set.

ELECTRICAL DATA (Late Models)

Model No.		HS21-036		HS21-048		HS21-060	
Line voltage data — 60 hz		208/230v - 1ph	208/230v - 3ph	208/230v - 1ph	208/230v - 3ph	208/230v - 1ph	208/230v - 3ph
Rec. Max fuse/circuit breaker size (amps)		40	25	45	35	60	45
*Minimum circuit ampacity		23.0	16.9	28.0	20.8	40.2	26.6
Compressor	Rated load amps	17.6	12.7	21.6	15.8	30.8	19.9
	Power factor	.98	.90	.98	.90	.92	.90
	Locked rotor amps	90.0	60.0	120.0	85.0	141.0	91.0
Condenser Coil Fan Motor	Full load amps	1.0	1.0	1.0	1.0	1.7	1.7
	Locked rotor amps	1.9	1.9	1.9	1.9	2.9	2.9

*Refer to National or Canadian Electrical Code manual to determine wire, fuse and disconnect size requirements.
NOTE — Extremes of operating range are plus 10% and minus 5% of line voltage.

**HS21 COMPONENTS (EARLY MODEL)
-411, -511, -651**

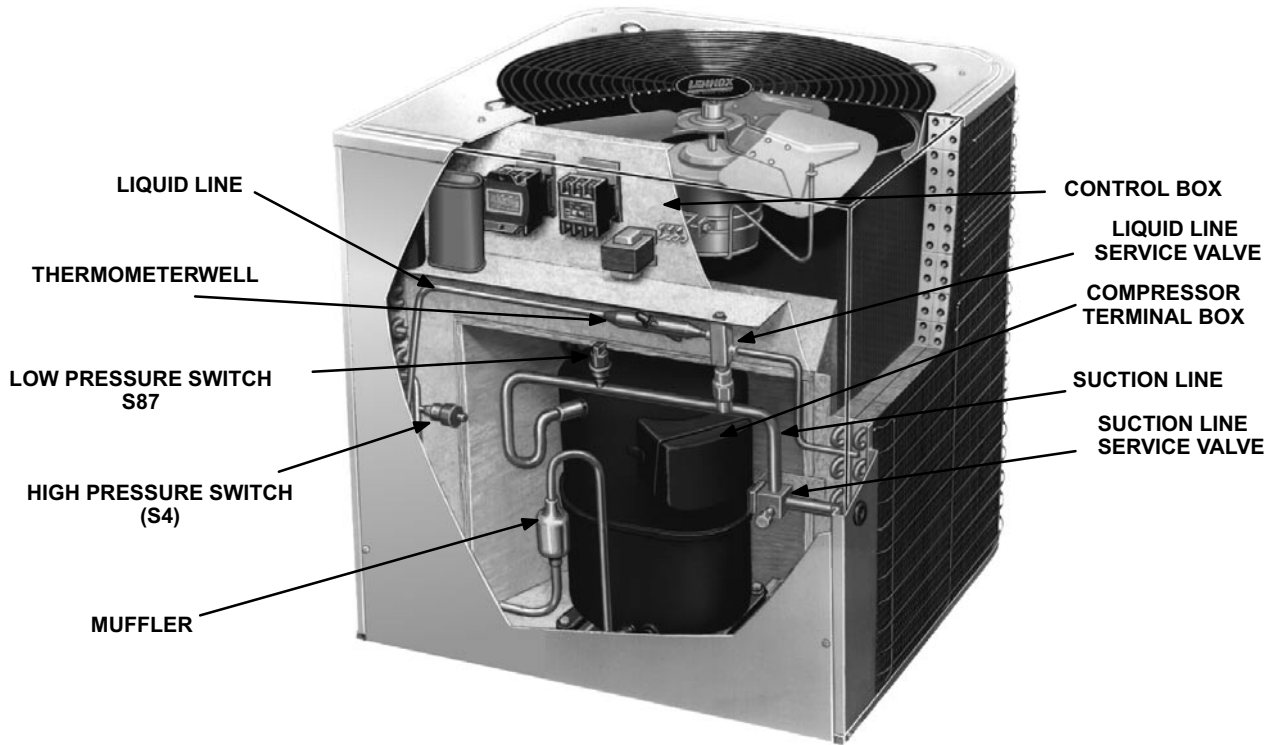

FIGURE 1

**HS21 COMPONENTS (LATE MODEL)
-036, -048, -060**

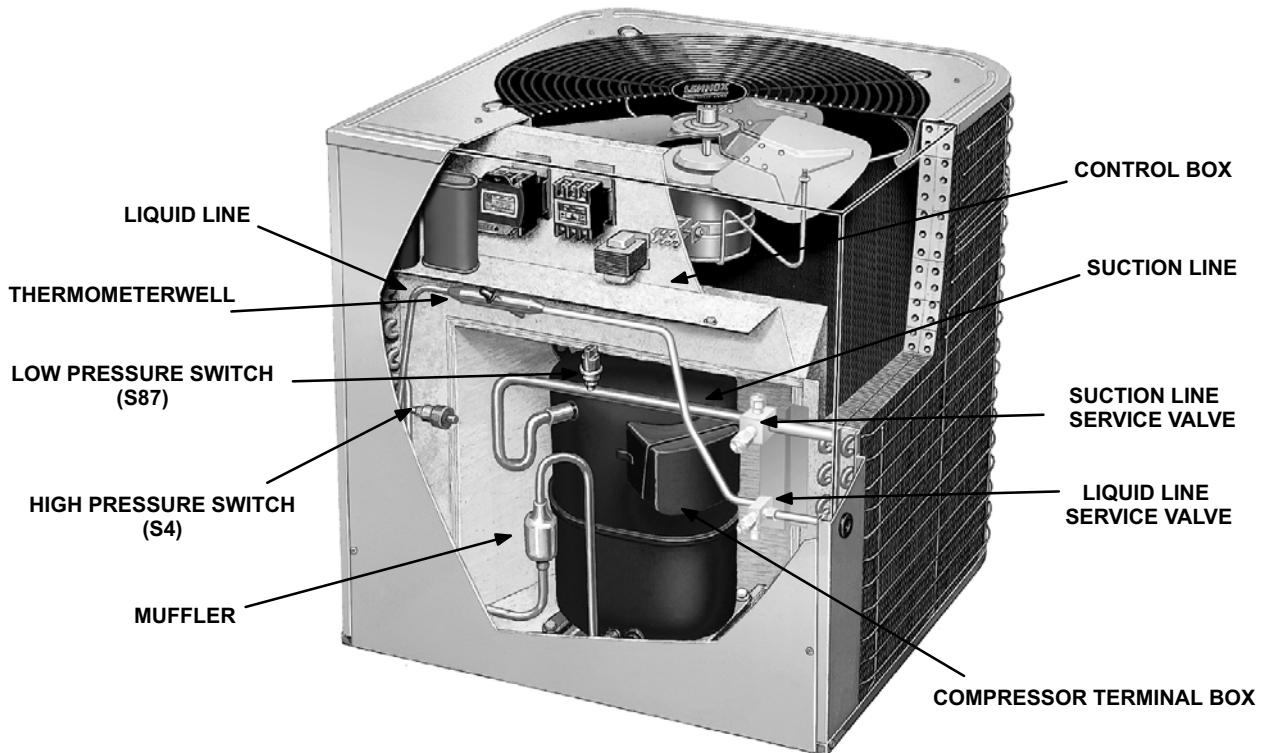

FIGURE 2

HS21 SINGLE PHASE CONTROL BOX COMPONENTS

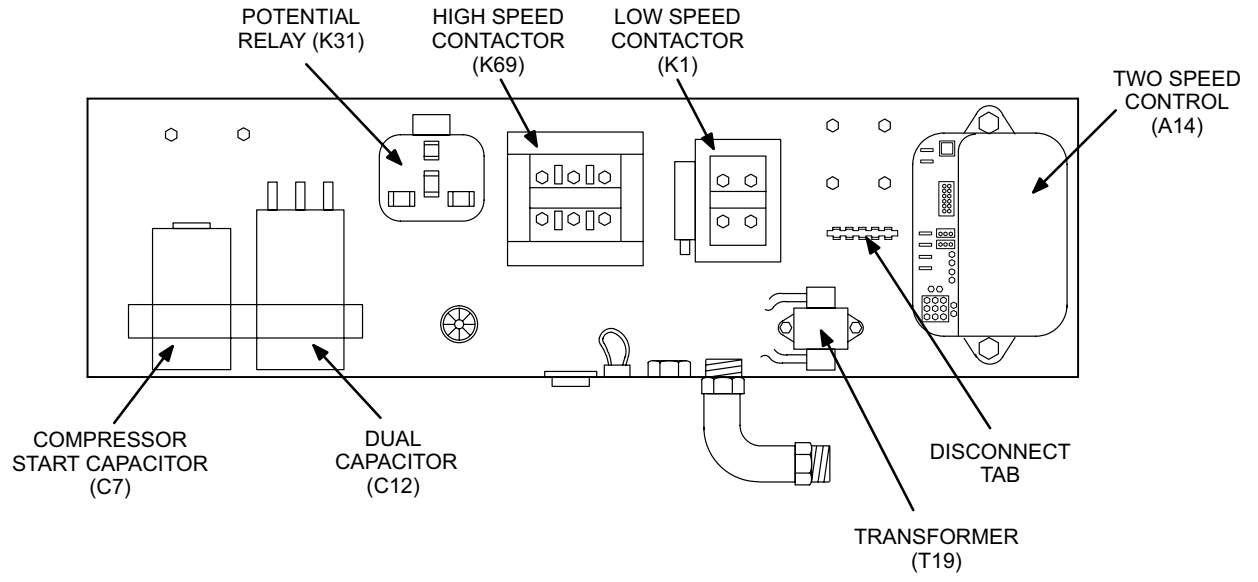

FIGURE 3

HS21 THREE PHASE CONTROL BOX COMPONENTS

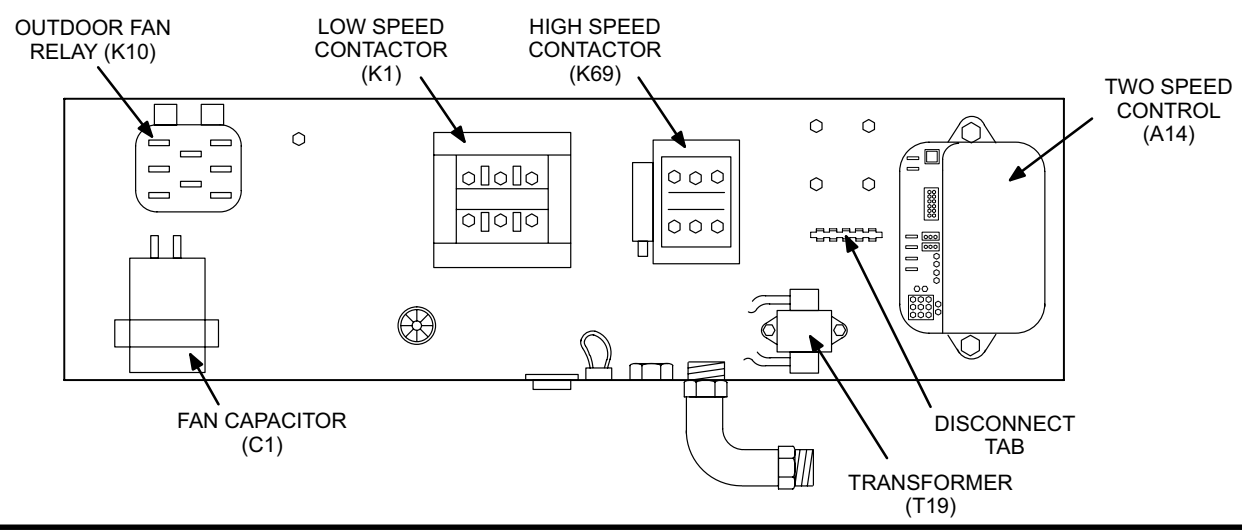

FIGURE 4

I-APPLICATION

All major components (indoor blower/coils) must be matched according to Lennox recommendations for the compressor to be covered under warranty. Refer to Engineering Handbook for approved system matchups. A misapplied system will cause erratic operation, can result in early failure of compressor or other components, and could affect the warranty.

ELECTROSTATIC DISCHARGE (ESD) Precautions and Procedures

⚠ CAUTION

Electrostatic discharge can affect electronic components. Take precautions during unit installation and service to protect the unit's electronic controls. Precautions will help to avoid control exposure to electrostatic discharge by putting the unit, the control and the technician at the same electrostatic potential. Neutralize electrostatic charge by touching hand and all tools on an unpainted unit surface before performing any service procedure.

II-UNIT COMPONENTS

HS21 unit components are shown in figures 1 and 2.

A-Control Box Components

HS21 control box is shown in figures 3 and 4. The control box is located in the top front section of the unit.

TABLE 1

HS21 Component	Source of Power
Two-Speed Control A14	24VAC from Outdoor Unit Transformer T19
Contactors K1	
Contactors K69	
High Pressure Limit S4	
Low Pressure Limit S87	
Fan Relay K10 (3 phase)	
Potential Relay K31 (1 phase)	Line Voltage
Crankcase Heater HR1	
Compressor Fan Dual Capacitor C12 (1 phase)	
Compressor Start Capacitor C7 (1 phase)	
Bleed Resistor R21 (1 phase)	
Fan Capacitor C1 (3 phase)	
Compressor B1	
Outdoor Fan B4	

1-Control Transformer T19

All units are equipped with a line voltage to 24VAC transformer which supplies power to unit controls as shown in table 1. The transformer is rated at 70VA and has two primary voltage taps (red - 208V, orange - 230V, and black - common). Refer to unit wiring diagram for detailed information regarding unit wiring.

2-Contactors K1 and K69

The compressor is energized by a set of contactors (K1 and K69) located in the control box. Contactors in HS21 units are energized as shown in table 2.

Contactors K1 energizes low speed compressor operation in all units (single-phase and three-phase.) In single-phase units K1 is a double-pole double-break contactor and in three-phase units K1 is a double-break contactor with three sets of normally open contacts and two sets of normally closed contacts. K1 is also equipped with a set of single-pole double-throw auxiliary contacts located on the side of the contactor. The contactor is energized in response to low speed thermostat demand (from two-speed control jackplug J44/P44 pin 9).

TABLE 2

Compressor Speed	Contactors Energized	
	Single-Phase	Three-Phase
Low	K1	K1
High	K1 & K69	K69

In single-phase units, K1 also de-energizes the crankcase heater and energizes the condenser fan during compressor operation.

Contactors K69 energizes high speed operation in all units (single-phase and three-phase). K69 is a double-break contactor with three sets of normally open contacts and two sets of normally closed contacts for single-phase models, and is a three pole double break contactor for three-phase models. This contact arrangement provides unique switching characteristics for two-speed operation. K69 is also equipped with a set of single-pole double-throw auxiliary contacts located on the side of the contactor. The contactor is energized in response to high speed thermostat demand from JP44-8 (two-speed control jackplug J44/P44 pin 8).

⚠ DANGER

**Electric Shock Hazard.
May cause injury or death.**



Line voltage is present at all components when unit is not in operation on units with single pole contactors.

Disconnect all remote electrical power supplies before opening this panel.

Unit may have multiple power supplies.

Contactors Operation: Single-Phase Units

Low speed demand energizes contactor K1. K1 de-energizes the crankcase heater and energizes the compressor and condenser fan. High speed demand energizes both contactors K1 and K69. K69 N.O. contacts close to redirect the circuit to the high speed start windings and the N.C. contacts open to de-energize the low speed start windings. K69-2 N.C. contacts and K69-2 N.O. contacts also switch when K69 is energized to ensure that K1 is energized with K69 during high speed operation (refer to unit wiring diagram).

Contactors Operation: Three-Phase Units

Low speed demand energizes contactor K1. K1 energizes the compressor and locks out contactor K69. High speed demand de-energizes K1 and energizes contactor K69. K69 locks out K1, through the K69-1 contacts and energizes the compressor on high speed.

K1 is wired so that when de-energized, the contactor forms a parallel common connection to the motor windings for high speed, forming a parallel "Delta" connection for Copeland compressors. When K1 is energized, the contactor forms a series Delta connection to the compressor windings. Refer to operation sequence in back of this manual for more information.

3-Outdoor Fan Relay K10 (three-phase only)

All three-phase HS21 series units use an outdoor fan relay (K10) to control the operation of the condenser fan and the crankcase heater. The relay energizes the condenser fan and de-energizes the crankcase heater during demand.

4-Potential Relay K31 (single-phase only)

All single-phase HS21 units use a potential relay to control the operation of the compressor starting circuit. The relay is normally closed when the compressor (contactor K1) is de-energized. Capacitor (C7) is connected in series to a set of normally closed K31 contacts and assists the compressor in starting. When K1 energizes, the compressor immediately begins start-up. K31 remains de-energized during compressor start-up and the start capacitor (C7) remains in the circuit. As the compressor gains speed K31 is energized by electromotive forces generated by the compressor. When K31 energizes, its contacts open to take the start capacitor out of the circuit.

5-Fan Capacitor C1 (three-phase units only)

All three-phase HS21 series units use single-phase permanent split capacitor (PSC) fan motors which require an external run capacitor. Ratings will be printed on side of capacitor.

6-Start Capacitor C7 (single-phase only)

All single-phase HS21 units are equipped with a start capacitor connected in parallel with the compressor side of the dual capacitor. The capacitor is switched off by the potential relay when the compressor nears full speed. The start capacitor is rated 145-175mfd. @ 330VAC in all single-phase units.

7-Bleed Resistor R21 (single-phase only)

All single-phase HS21 units are equipped with a bleed resistor connected in parallel with start capacitor C7. The resistor is used to slowly discharge the capacitor when not in use. R21 is a 15,000 ohm 2 watt resistor.

8-Dual Capacitor C12 (single-phase only)

All single-phase HS21 units use a single dual capacitor to maximize motor efficiency in both the fan motor and the compressor, which use PSC motors. A dual capacitor has two independent capacitors inside one can. Each side of the capacitor has different ratings. Ratings will be printed on side of capacitor. The dual capacitor is wired in parallel with the start capacitor and is electrically connected as shown in the unit wiring diagram.

9-Disconnect Tab

The disconnect tab has 10 pins where 10 wire connections are made from the various components in the control box. The disconnect tab simplifies the connections between the components in the control box.

10-TSC5 Two Speed Control A14

The TSC (A14) two-speed control (figure 7) is a Lennox-built control designed for use with two-speed condensing units. The control provides automatic switching from low speed to high speed operation and back. A14 is electrically connected as shown in the unit wiring diagram. The two speed control is covered in detail in section III.

B-Unit Components

1-Compressor B1

All compressors are rated at 208/230 VAC and may be single-phase or three-phase. All compressors are equipped with internal pressure relief valves set at 450 ± 50 psig. Compressors in all units use insertion-type crankcase heaters. See "ELECTRICAL DATA" or compressor nameplate for specifications. Figure 5 shows the compressor terminal box.

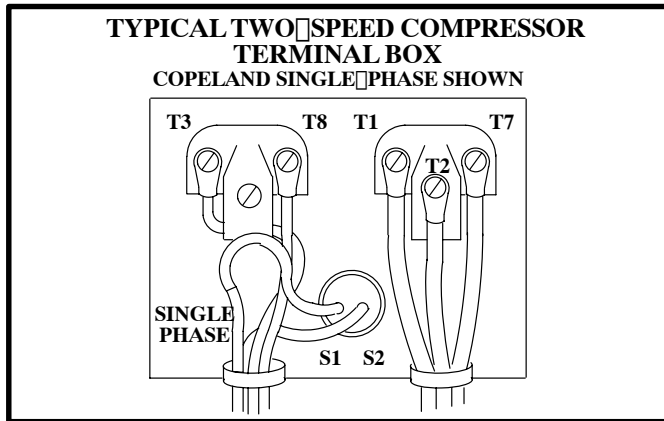

FIGURE 5

2-Compressor Heater HR1 (all units)

A crankcase heater is used on all HS21 models. The well-mounted, insertion-type heater is self-regulating. Heaters are rated at 40 watts for all HS21 models. The heater is thermostat-actuated and operates only when demand is satisfied.

3-Outdoor Fan Motor B4

The table on page 1 of this manual shows the specifications of outdoor fans used in all HS21 units. In single-phase units, the outdoor fan is controlled by the compressor contactor K1. In three-phase units, the outdoor fan is controlled by relay K10. See figure 6 if outdoor fan motor replacement is necessary.

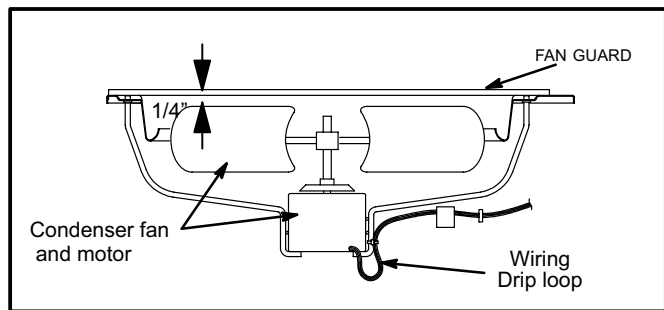

FIGURE 6

4-High Pressure Limit Switch S4

All units are equipped with a SPST N.C. high pressure limit switch mounted on the compressor discharge line. When the pressure rises above 410 ± 10 psig, the switch opens to shut off the compressor. The switch is manually reset and is electrically connected in series with low pressure switch S87 in the two-speed control's safety circuit.

5-Low Pressure Switch S87

All units are equipped with a SPST N.C. low pressure switch mounted on the compressor suction line. The switch opens, shutting off the compressor, when suction line pressure drops below 25 ± 5 psig. When the pressure rises above 55 ± 5 psig the switch automatically resets (closes). The switch is electrically connected in series with high pressure switch S4 in the two-speed control's safety circuit.

C-Optional Equipment

1-Humidity control A20

The CCB1 EfficiencyPlus Comfort Management System may be used with the HS21 unit to control humidity. The EfficiencyPlus automatically controls the compressor and the indoor blower, to maintain a selected level of relative humidity throughout the conditioned space during a thermostat demand. The EfficiencyPlus "DS" output is designed to directly control the variable speed motors used in the CB21, G21V, CB31MV and G32V indoor units.

2-EBR1 Control Kit A51

EBR1 Blower Relay Kit provides the option of varying indoor blower speeds of multi-tap motors when using the EfficiencyPlus with a two-speed HS21. When the EfficiencyPlus is used with the HS21, most of the dehumidification is provided by forcing the compressor into high speed when the thermostat calls for low speed. The kit provides more dehumidification by simultaneously decreasing the indoor blower speed.

3-Room Thermostat S1

The HS21 unit can be used with numerous types of thermostats. The two-heat two-cool electromechanical thermostat (51H34) is recommended. The subbase is furnished with the thermostat and features system selector switch (Off-Heat-Auto-Cool) and fan switch (Auto-On) for continuous or intermittent blower operation. The thermostat also has an indicator light to indicate low or high speed compressor operation.

4-Low Pressure (Low Ambient) Switch S11

The HS21 unit will operate satisfactorily down to 45°F (7°C) outdoor air temperature without any additional controls. For cases where operation of the unit is required at low ambient, a Low Ambient Control Kit LB-57113BC (24H77) can be added in the field, enabling the unit to operate properly down to 30°F (-1°C).

III-TSC5 TWO-SPEED CONTROL OPERATION

The TSC (A14) two-speed control contains relays which energize compressor operation in response to thermostat demand. High speed operation can be energized and de-energized without passing through low speed. The control also contains safety timed-off delays and compressor over-temperature sensing which protect the compressor. A timed-off delay in the control prevents short cycling by locking out compressor operation for five minutes after the end of a thermostat demand or after a power failure. The control also counts "unit fault conditions." When the compressor stops due to a safety limit trip, or if the compressor winding temperature becomes too hot, the control's internal cycle counter accumulates one fault. If three unit faults are counted during the same thermostat demand, the control "locks out" and stops all unit operation. The control can be reset by breaking and remaking thermostat demand. Unit faults are erased when power is interrupted. When thermostat demand changes stages, compressor operation stops for approximately one minute to allow refrigerant pressure to equalize in the system.

A manual override button aids servicing and troubleshooting, on the control. The manual override button, when pressed and released, bypasses the five-minute delay so low speed or high speed operation can be immediately energized. However, the control provides a one-minute delay between speed changes, which can not be bypassed.

Do not use the override button immediately after power-up. If the button is pushed during the ten-second power-up delay, it has no effect. The control completes the five-minute delay.

The control continually self-tests its internal circuits and uses the diagnostic lights to indicate control failure.

Normal Operation Sequence

- 1- The control begins a five-minute delay during which the unit is not operational (control and outdoor unit do not respond to thermostat demand). Once the five-minute delay is complete, the control waits in "OFF" mode for thermostat demand.
- 2- After receiving a thermostat demand, the TSC delays three seconds before responding.
- 3- Low speed demand (JP44-9) energizes low speed operation OR high speed demand (JP44-8) energizes high speed operation.
- 4- During unit operation, if low speed demand changes to high speed demand or if high speed demand changes to low speed, the control delays three seconds before responding. Then, all unit operation stops for 60±5 seconds (control de-energizes JP44-8 and JP44-9). This allows refrigerant pressure to equalize in the system. At the end of the 60±5 second delay, the control responds to whatever thermostat demand is present. If no thermostat demand is present, the control resets (see unit fault conditions section) and returns to step 2 above.
- 5- When thermostat demand is satisfied, all unit operation stops after a three-second delay (control de-energizes JP44-8 and JP44-9), the control resets (see unit fault conditions section) and returns to step two.
- 6- General Operation
On power-up, the control begins a ten-second initial delay.

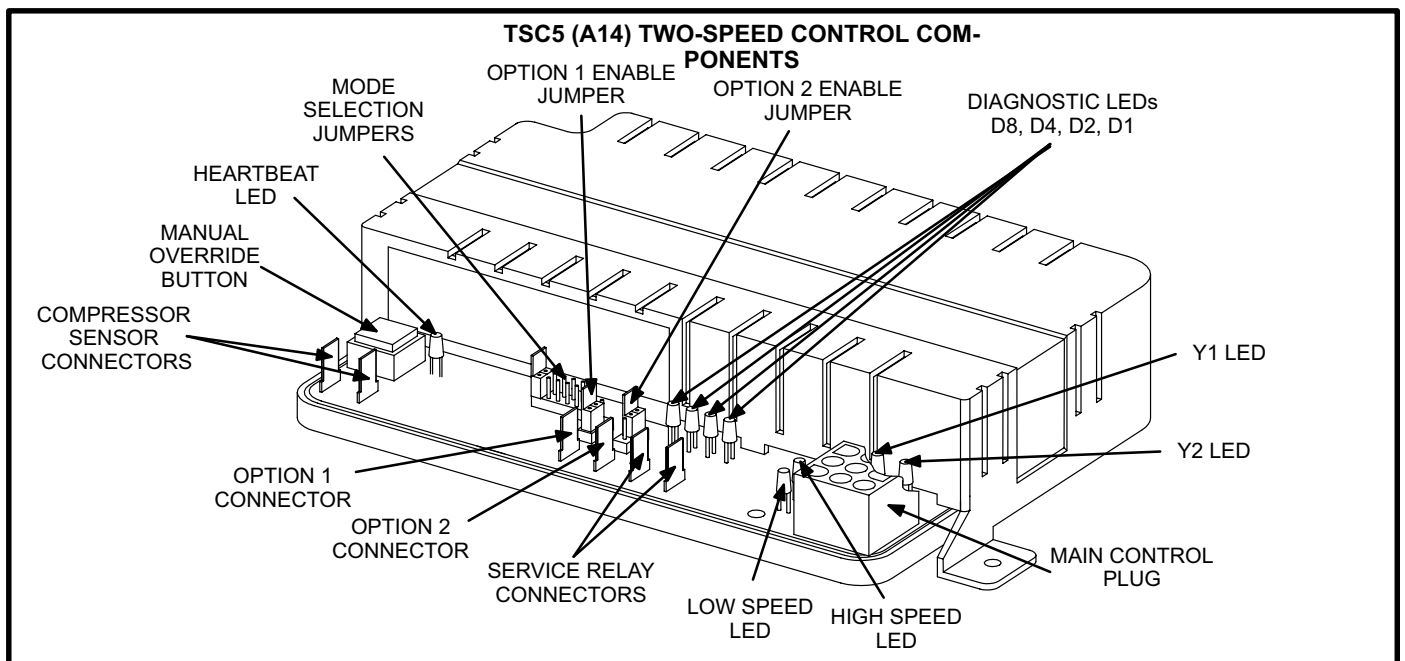

FIGURE 7

TSC5 (A14) MAIN CONTROL PLUG

JP44-1	24VAC POWER (INPUT)
JP44-2	24VAC COMMON
JP44-3	24VAC (SPARE, NOT USED)
JP44-4	2nd STAGE THERMOSTAT DEMAND
JP44-5	THERMOSTAT COMMON (C)
JP44-6	1st STAGE THERMOSTAT DEMAND
JP44-7	24VAC FROM SAFETY SWITCHES TO INTERNAL CONTACTOR COIL (INPUT)
JP44-8	HIGH SPEED (24VAC OUTPUT)
JP44-9	LOW SPEED (24VAC OUTPUT)

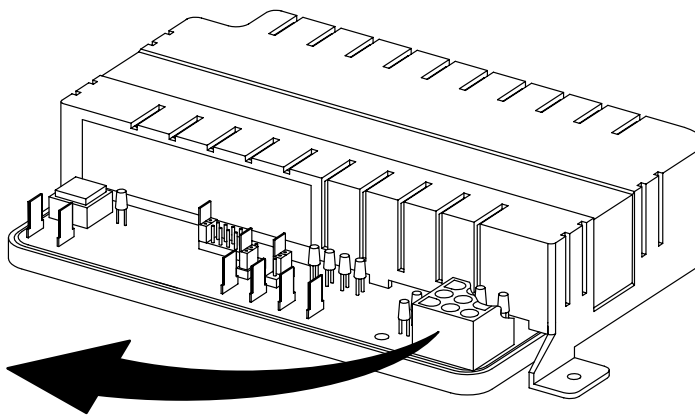
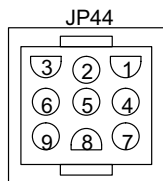

FIGURE 8

Two-Speed Control Fault Conditions

If the control is in low speed operation, high speed operation, "OFF" mode or speed change delay, the control "counts" or accumulates faults on an internal cycle counter. Only faults which occur during compressor operation and which cause the compressor to shut off are counted. After a fault is counted, the control stops unit operation, resets and begins a five-minute time delay (step 2, operation sequence). If the control senses a fault at the end of five minutes, the unit will not restart. If the control counts three faults during the same thermostat demand, the control locks out unit operation.

! IMPORTANT

If the control locks out, it can be reset by breaking thermostat demand for about five seconds then re-making thermostat demand. Also, anytime thermostat demand is removed or power is interrupted, the control resets to zero faults.

! IMPORTANT

If the cycle counter counts three faults during the same thermostat demand, the control locks out. The outdoor unit remains inoperable until thermostat demand is broken. This indicates further troubleshooting is needed. Though the control can be reset by breaking thermostat demand, the unit may remain inoperable. The high pressure or low pressure conditions may still exist and must be located and corrected before the unit can be placed back in service. See diagnostic codes to determine problem.

! IMPORTANT

Intermittent continuity (bad connection or failing components) can cause false lockout or lit diagnostic lights. Check electrical connections thoroughly.

A fault occurs when:

- 1- Compressor operation is monitored by high and low pressure switches. These controls are wired in series. If either one trips, compressor operation is interrupted and one fault is counted. The control locks out compressor operation for a minimum of five minutes when a safety device terminates operation. High pressure switch must be reset manually but low pressure switch resets automatically.
It is likely that the control could count three unit faults from the low pressure switch during a single thermostat demand since this switch resets automatically. However, the cycle counter can only count unit faults from the high pressure switch if the reset button is pushed without interrupting thermostat demand.
- 2- On all units using the TSC two-speed control, terminals S1 and S2 on the control are connected to temperature sensors (thermistors) which monitor the temperature of the compressor motor windings. The two-speed control measures the resistance through the sensors. The sensors increase their resistance as temperature increases (for example, too much superheat). When the resistance through the sensors increases above a preset limit, the control stops compressor operation for a minimum of five minutes. As the compressor windings cool, the resistance through the sensors drops below the reset limit, the control resets automatically and one fault is counted.

Check sensors by measuring resistance (ohms) through the sensors with the wires disconnected from the control (unit not running). The sensor wires are not polarity sensitive. Table 3 shows winding temperature sensor resistance values which will cause the TSC to lock out. When unit is operating normally, resistance through the sensors should be below the trip value shown in table 3.

TABLE 3

Compressor Winding Temperature Sensor	Trip Ohms Temp. Rise	Reset Ohms Temp. Fall
TSC5 Copeland Compressor	25K to 35K	8.4K to 10K

The control can be checked by comparing the resistance measured through the sensors to the voltage measured across the sensor terminals with the unit running. Table 4 shows voltage measured across two-speed control terminals S1 and S2 with the compressor running.

TABLE 4

COMPRESSOR WINDING SENSOR OPERATING RANGE		
Resistance Through Compressor Winding Temperature Sensor K-ohms (ohms x 1000)	Voltage Across TSC5 compressor sensor terminals with Unit Running DC Volts	
0	0	} Reset Range
1.0	1.70 - 1.82	
5.5	6.07 - 6.48	
6.9	6.86 - 7.33	
8.4	7.55 - 8.07	
10.0	8.16 - 8.72	
16.0	9.69 - 10.36	
20.0	10.34 - 11.05	
24.0	10.82 - 11.57	
25.0	10.93 - 11.68	
30.0	11.35 - 12.14	
35.0	11.68 - 12.48	

MODE SELECTION JUMPERS

The control has six mode selection jumpers for selection of operating modes and problem code recall or test. Choose one of the first four modes for operation.

Normal: Normal operation (default mode). Unit runs on high or low speed as the indoor thermostat load demands.

Latch 1: After high speed demand is met, the unit remains in high speed until the low speed demand is satisfied.

Latch 2: After the unit operates in low speed for 15 minutes consecutively, it switches to high speed until low speed demand is satisfied.

Latch 3: After the unit operates in low speed for 30 minutes consecutively, it switches to high speed until low speed demand is satisfied.

Recall: Used in conjunction with the bypass button to recall the stored problem codes.

Test: Used in conjunction with the control button to start test mode.

Latch 2 or 3 modes are recommended in high humidity areas. If the jumper falls off or is removed, the control will continue to operate in the previously set mode until the control is reset due to loss of power, then the control will default to the Normal mode. The latch feature does not affect the indoor blower operation.

TEST MODE

The control has a test mode. To initiate this mode, move the jumper to the test position and push the control button. The unit will operate in low speed for 10 seconds, turn off for ten seconds, then operate in high speed for 10 seconds. The control will only go into the test mode if there is no thermostat demand and 5 minutes has elapsed since the unit ran. The indoor blower does not run during this mode. The test mode cannot run more than once every 5 minutes.

LED LIGHTS

Y1 and Y2 lights are connected directly to the inputs from the thermostat. They indicate low and high speed demand, respectively.

The HI and LO lights are connected directly across the contactor coils. They indicate if the high and low speed contactors are energized.

The HEARTBEAT light is connected to the microcontroller unit (MCU). It indicates when the control's MCU is operating correctly, and also when the control is in delay mode. It blinks at a rate of four times a second when the MCU is operating properly and at a rate of once every two seconds when in the delay mode (such as the 1 or 5 minute delay). If the LED is continuously on or off (assuming the power is on), the MCU is not operating properly and the control needs to be replaced.

The D1, D2, D4, and D8 (see figure 7) diagnostic lights display diagnostic codes to aid in unit troubleshooting. Refer to Diagnostic Code Table (table 5).

Diagnostic Code Display

A problem code is normally displayed only for the duration of the error. There is one exception. During a lockout, the code for the problem causing the lockout flashes once a second even if the problem condition no longer exists. If other problems occur during a lockout condition, the codes for those problems will be saved in memory, but not displayed. The stored problem codes are displayed by recalling them from memory. The diagnostic codes can be re-displayed by setting the jumper to the recall position. The stored codes are displayed by pushing the push button. As previously mentioned, the push button is used to bypass the five-minute delay and to initiate the test mode. In addition, the button is used to step back through the stored diagnostic codes and erase the diagnostic code memory. Diagnostic codes are recalled in the

reverse order of actual occurrence. Each subsequent button push will display additional codes until the last one, which will stay on with additional button pushes. Hold the button down until the lights go off (approximately five seconds) to erase the memory. The control has a nonvolatile memory that stores the 63 most recent diagnostic codes. These codes are stored in memory, even in the event of a power loss.

Not all codes cause lockouts or indicate problems. The purpose of the diagnostic lights is to let the installer or service technician know what is going on with the entire system, not just the two-speed control. Some codes do indicate malfunctions or problems with either the control or the HS21, while others inform the technician of the unit's status. All codes, except for three, are stored in memory and may be recalled.

Code 1 - Power Loss for Two Electrical Cycles

This code indicates that the unit's power skipped two electrical cycles (33-40 milliseconds). It may suggest that power to the unit is "dirty" or is of low quality. Code 1 is stored.

Code 2 - Input Indication

This code indicates that a change has been made and that the control acknowledges the change. It does not indicate a problem condition. It indicates activity such as jumper setting changes, delay overrides, or addition of an optional safety device to Option 1 or 2. Code 2 is not stored.

Code 3 - Unsteady Thermostat Input

Code 3 indicates intermittent inputs from the room thermostat. Most likely, there is a loose connection at the thermostat when this condition appears. Code 3 is stored.

Code 4 - Pressure Switch Opens < Two Minutes

If the low or high pressure switch opens after the compressor has run for **less than** two minutes, Code 4 will be displayed. This may indicate blockage or fan failure. Code 4 is stored. If the unit still operates after code is displayed, the low pressure switch stops operation (low pressure is auto-reset). Check for low system charge.

Code 5 - Pressure Switch Opens > Two Minutes

If the low or high pressure switch opens after the compressor has run for **more than** two minutes, Code 5 is displayed. This may indicate an improper charge or coil obstruction. Code 5 is stored. If the unit still operates after code is displayed, the low pressure switch stops operation (low pressure is auto-reset). Check for low system charge.

**TABLE 5
TSC5 DIAGNOSTICS CODES**

CODE NUMBER	CONDITION	DISPLAY LIGHTS			
		8	4	2	1
1	Power loss for two cycles	OFF	OFF	OFF	ON
2	Input Indication	OFF	OFF	ON	OFF
3	Unsteady Input	OFF	OFF	ON	ON
4	Pressure Switch Open <2 minutes	OFF	ON	OFF	OFF
5	Pressure Switch Open > 2 minutes	OFF	ON	OFF	ON
6	Hot Compressor < 5 min. (or open sensor)	OFF	ON	ON	OFF
7	Hot Compressor > 5 min. (or open sensor)	OFF	ON	ON	ON
8	Option 1 < 5 minutes	ON	OFF	OFF	OFF
9	Option 1 > 5 minutes	ON	OFF	OFF	ON
10	Option 2 Open	ON	OFF	ON	OFF
11	Compressor Sensor Problem	ON	OFF	ON	ON
12	Not Used on TSC5	ON	ON	OFF	OFF
13	Not Used	ON	ON	OFF	ON
14	Test Mode	ON	ON	ON	OFF
15	No Jumper in place Indication	ON	ON	ON	ON

Code 6 - Hot Compressor < Five Minutes

Code 6 indicates the compressor temperature exceeded its limit after running **less than** five minutes. Code 6 is stored.

Code 7 - Hot Compressor > Five Minutes

Code 7 indicates the compressor temperature exceeded its limit after running **more than** five minutes. Code 7 is stored.

Code 8 - Option 1 < Five Minutes

Code 8 occurs if the Option 1 safety device switch opens after the compressor runs **less than** five minutes. Code 8 is stored.

Code 9 - Option 1 > Five Minutes

Code 9 occurs if the Option 1 safety device switch opens after the compressor runs **more than** five minutes. Code 9 is stored.

Code 10 - Option 2

Code 10 is displayed if the Option 2 safety device switch opens. Code 10 is stored.

Code 11 - Compressor Temperature Sensor Shorted

This code indicates that the compressor temperature sensor wires have shorted together. Code 11 is stored.

Code 12 - Not used on TSC5

This code does not pertain to the two-speed control (TSC5) used on condensing units.

Code 13 - Not Used

This code may be used in future models of the two-speed control, but at this time has no function and, therefore, is not stored.

Code 14 - Test Mode

Code 14 does not indicate a problem. The control is in TEST mode when this code is displayed. See Mode Jumper Selections section.

Code 15 - No Jumper in Place

Code 15 is displayed when the mode jumper is not in place. Make sure jumper is placed securely across the selected set of pins for the appropriate mode of operation.

SERVICE RELAY

The control has a built-in service relay. This relay controls the thermostat service light or communicates with an alarm device. The relay signals the alarm device in such a manner that the alarm device can distinguish between a lockout and a non-lockout condition. The relay contacts are normally open when no problems or lockout conditions occur. A non-lockout condition is reported by closing the contacts for the duration of the next no-demand period. If the control goes into a lockout state, the relay will close and remain closed until the next loss of demand. If the service light on the room thermostat is connected to the service relay, the light will turn on if the control is in a lockout. It will not turn on if the control is detecting non-lockout problems. In order for the service relay to indicate only a lockout condition, one side of the relay must be wired to the alarm and the other side to Y2. During a simultaneous Y1 and Y2 demand with a non-lockout condition, the alarm will energize for a very short duration (.2 seconds). If both an alarm device and thermostat service lights are used, an additional external relay may be required depending on the thermostat used.

OPTIONAL INPUTS

The control has two optional inputs for additional protection devices. If options 1 or 2 are going to be used, move the three pin mini-jumper to the YES side. OPT 1 input will lock out the compressor on the third count. OPT 2 input will not lock out the compressor at any time, but will display and store the problem code (see Diagnostic code Table). These inputs are designed for normally closed switches connected to 24VAC.

⚠ CAUTION

Do not remove the jumpers unless additional protection controls are going to be installed. If OPT 1 jumper is not connected to the NO pin, the control will lock out the compressor. If OPT 2 is not connected to the NO pin, the display only shows the problem code.

IV-REFRIGERANT SYSTEM**A-Plumbing**

Field refrigerant piping consists of liquid and suction lines from the indoor coil to the outdoor unit (sweat connections). Use Lennox L10 series line sets as shown in table 6 or field fabricated refrigerant lines. Install filter drier, provided with unit, in the liquid line as close as possible to the expansion device.

TABLE 6

HS21 UNIT	LIQUID LINE	VAPOR LINE	L10 LINE SETS	L15 LINE SETS
-410 -036	3/8 In	3/4 In	L10-41 20 ft - 50 ft.	L15-41 15 ft. - 50 ft.
-510 -048		7/8 In	L10-65 30 ft. - 50 ft.	L15-65 15 ft. - 50 ft.
-650 -060		1-1/8 In	FIELD FABRICATED	

B-Discharge Muffler

All units are equipped with a discharge muffler located in the discharge line of the compressor. The muffler attenuates discharge gas pulsations from the compressor to lower sound levels. The discharge muffler is located immediately in front of the compressor in the compressor compartment. See figure 1 or 2.

C-Thermometer Well

All units are equipped with a thermometer well for use in measuring liquid line temperature when charging the unit. The thermometer well is used in all Lennox recommended charging procedures. It is located in the liquid line adjacent to the liquid line service valve.

D-Service Valves

The liquid line and suction line service valves and gauge ports are accessible by removing the compressor access cover. Full service liquid and suction line valves are used. See figures 9 and 11. The service ports are used for leak testing, evacuating, charging and checking charge.

1-Liquid Line Service Valve

A full-service liquid line valve made by one of several manufacturers may be used. All liquid line service valves function the same way, differences are in construction. Valves manufactured by Parker are forged assemblies. Valves manufactured by Primore are brazed together. Valves are not rebuildable. If a valve has failed it must be replaced. The liquid line service valve for HS21-411, -511, and -060 is illustrated in figure 9. The liquid line service valve for HS21-036, -048 and -060 is illustrated in figure 10.

The valve is equipped with a service port. There is no schrader valve installed in the liquid line service port. A service port cap is supplied to seal off the port.

The liquid line service valve is a front and back seating valve. When the valve is backseated the service port is not pressurized. The service port cap can be removed and gauge connections can be made.

⚠ CAUTION

A schrader valve is not provided on the liquid line service port. The service port cap is used to seal the liquid line on the service valve. Access to service port requires backseating the service valve to isolate the service port from the system. Failure to do so will cause refrigerant leakage.

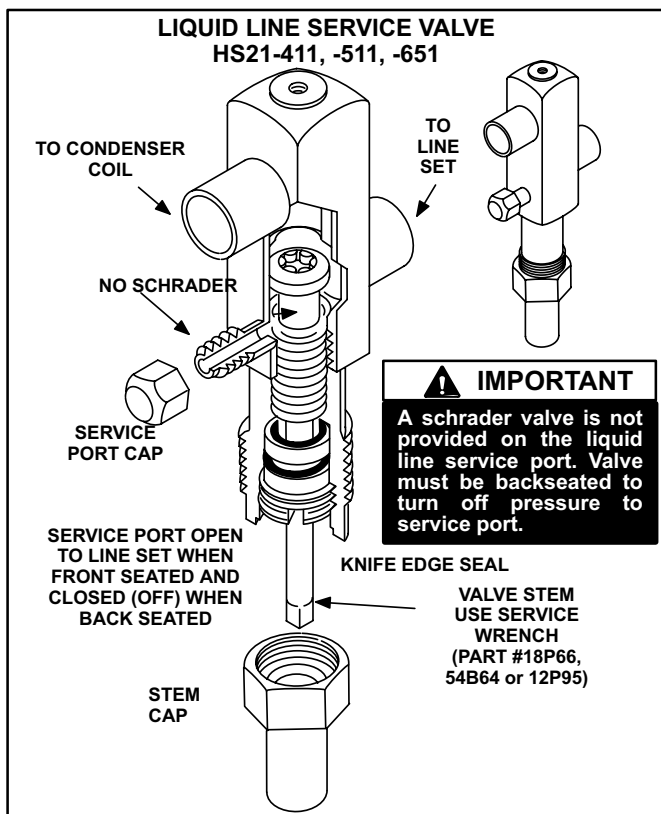

FIGURE 9

To Access Service Port:

- 1- Remove the stem cap. Use a service wrench to make sure the service valve is backseated.
- 2- Remove service port cap and connect high pressure gauge to service port.
- 3- Using service wrench, open valve stem (one turn clockwise) from backseated position.
- 4- When finished using port, backseat stem with service wrench. Tighten firmly.
- 5- Replace service port and stem cap. Tighten finger tight, then tighten an additional 1/6 turn.

To Close Off Service Port:

- 1- Using service wrench, backseat valve.
 - a-Turn stem counterclockwise.
 - b-Tighten firmly.

To Open Liquid Line Service Valve:

- 1- Remove the stem cap with an adjustable wrench.
- 2- Using service wrench, backseat valve.
 - a-Turn stem counterclockwise until backseated.
 - b-Tighten firmly.
- 3- Replace stem cap, finger tighten then tighten an additional 1/6 turn.

To Close Liquid Line Service Valve:

- 1- Remove the stem cap with an adjustable wrench.
- 2- Turn the stem in clockwise with a service wrench to front seat the valve. Tighten firmly.
- 3- Replace stem cap, finger tighten then tighten an additional 1/6 turn.

2-Suction Line (Seating Type) Service Valve

A full service non-backseating suction line service valve is used on all HS21 series units. Different manufacturers of valves may be used. All suction line service valves function the same way, differences are in construction.

Valves manufactured by Parker are forged assemblies. Primore and Aeroquip valves are brazed together. Valves are not rebuildable. If a valve has failed it must be replaced. The suction line service valve for HS21-411, -511 and -060 is illustrated in figure 11. The suction line service valve for HS21-036, -048 and -060 is illustrated in figure 12.

The valve is equipped with a service port. A schrader valve is factory installed. A service port cap is supplied to protect the schrader valve from contamination and assure a leak free seal.

To Access Schrader Valve:

- 1- Remove service port cap with an adjustable wrench.
- 2- Connect gauge to the service port.
- 3- When testing is completed, replace service port cap. Tighten finger tight, then an additional 1/6 turn.

To Open Suction Line Service Valve:

- 1- Remove stem cap with an adjustable wrench.
- 2- Using service wrench and 5/16" hex head extension back the stem out counterclockwise until the valve stem just touches the retaining ring.
- 3- Replace stem cap tighten firmly. Tighten finger tight, then tighten an additional 1/6 turn.

⚠ DANGER

Do not attempt to backseat this valve. Attempts to backseat this valve will cause snap ring to explode from valve body under pressure of refrigerant. Personal injury and unit damage will result.

To Close Suction Line Service Valve:

- 1- Remove stem cap with an adjustable wrench.
- 2- Use service wrench and 5/16" hex head extension turn stem clockwise to seat the valve. Tighten firmly.
- 3- Replace stem cap. Tighten finger tight, then tighten an additional 1/6 turn.

V-CHARGING

The unit is factory-charged with the amount of HCFC-22 refrigerant indicated on the unit rating plate. This charge, as shown in the specification table on page 1, is based on a matching indoor coil and outdoor coil with 15 feet of line set.

For varying lengths of line set, refer to table 7 for refrigerant charge adjustment. A blank space is provided on the unit rating plate to list actual field charge.

TABLE 7

LIQUID LINE SET DIAMETER	Ounce per 5 foot (ml per mm) adjust from 15 foot (4.5 m) line set*
1/4 in. (6 mm)	1 ounce per 5 feet (30 ml per 1524 mm)
5/16 in. (8mm)	2 ounce per 5 feet (60 ml per 1524 mm)
3/8 in. (10 mm)	3 ounce per 5 feet (90 ml per 1524 mm)

*If line set is greater than 15 ft. (4.5m) add this amount. If line set is less than 15 feet (4.5m) subtract this amount

Units are designed for line sets up to 50 ft. Consult Lennox Refrigerant Piping Manual (Corp. 9351-L9) for line sets over 50 ft.

A-Leak Testing

After the line set has been connected to the indoor and outdoor units, check the line set connections and indoor unit for leaks.

⚠ WARNING

Refrigerant can be harmful if it is inhaled. Refrigerant must be used and recovered responsibly.

Failure to follow this warning may result in personal injury or death.

⚠ WARNING



Danger of explosion: Can cause equipment damage, injury or death. Never use oxygen to pressurize a refrigeration or air conditioning system. Oxygen will explode on contact with oil and could cause personal injury.

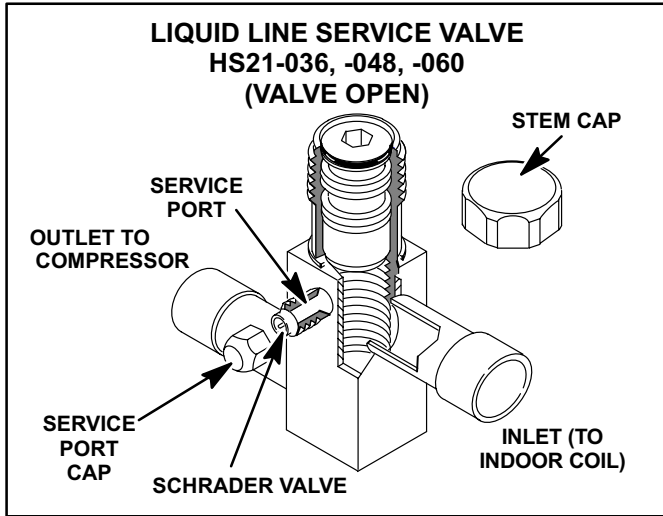

FIGURE 10

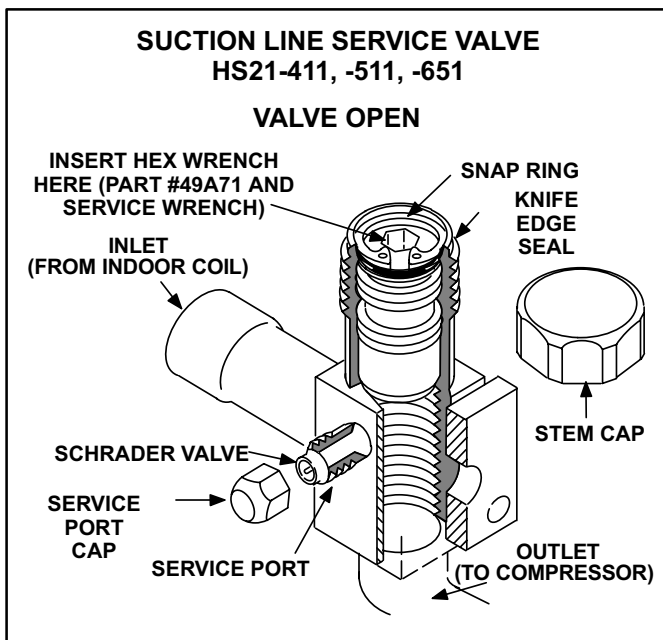

FIGURE 11

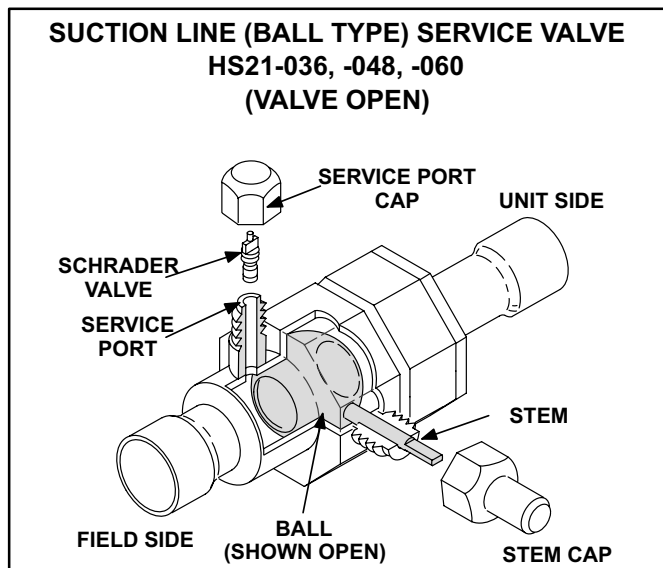

FIGURE 12

WARNING

Danger of explosion: Can cause equipment damage, injury or death. When using a high pressure gas such as dry nitrogen to pressurize a refrigeration or air conditioning system, use a regulator that can control the pressure down to 1 or 2 psig (6.9 to 13.8 kPa).

Using an Electronic Leak Detector or Halide

- 1 - Connect a cylinder of HCFC-22 to the center port of the manifold gauge set.
 - 2 - With both manifold valves closed, open the valve on the HCFC-22 cylinder (vapor only).
 - 3 - Open the high pressure side of the manifold to allow the HCFC-22 into the line set and indoor unit. Weigh in a trace amount of HCFC-22. [A trace amount is a maximum of 2 ounces (57 g) or 3 pounds (31 kPa) pressure.] Close the valve on the HCFC-22 cylinder and the valve on the high pressure side of the manifold gauge set. Disconnect the HCFC-22 cylinder.
 - 4 - Connect a cylinder of nitrogen with a pressure regulating valve to the center port of the manifold gauge set.
 - 5 - Connect the manifold gauge set high pressure hose to the vapor valve service port. (Normally, the high pressure hose is connected to the liquid line port; however, connecting it to the vapor port better protects the manifold gauge set from high pressure damage.)
 - 6 - Adjust the nitrogen pressure to 150 psig (1034 kPa). Open the valve on the high side of the manifold gauge set which will pressurize line set and indoor unit.
 - 7 - After a few minutes, open a refrigerant port to ensure the refrigerant you added is adequate to be detected. (Amounts of refrigerant will vary with line lengths.) Check all joints for leaks. Purge nitrogen and HCFC-22 mixture. Correct any leaks and recheck.
- 2 - Connect micron gauge.
 - 3 - Connect the vacuum pump (with vacuum gauge) to the center port of the manifold gauge set.
 - 4 - Open both manifold valves and start the vacuum pump.

B-Evacuating the System

Evacuating the system of noncondensables is critical for proper operation of the unit. Noncondensables are defined as any gas that will not condense under temperatures and pressures present during operation of an air conditioning system. Noncondensables and water vapor combine with refrigerant to produce substances that corrode copper piping and compressor parts.

IMPORTANT

Use a thermocouple or thermistor electronic vacuum gauge that is calibrated in microns. Use an instrument that reads from 50 microns to at least 10,000 microns.

- 1 - Connect manifold gauge set to the service valve ports:
 - low pressure gauge to *vapor* line service valve
 - high pressure gauge to *liquid* line service valve
- 2 - Connect micron gauge.
- 3 - Connect the vacuum pump (with vacuum gauge) to the center port of the manifold gauge set.
- 4 - Open both manifold valves and start the vacuum pump.
- 5 - Evacuate the line set and indoor unit to an **absolute pressure** of 23,000 microns (29.01 inches of mercury). During the early stages of evacuation, it is desirable to close the manifold gauge valve at least once to determine if there is a rapid rise in **absolute pressure**. A rapid rise in pressure indicates a relatively large leak. If this occurs, repeat the leak testing procedure.
*NOTE - The term **absolute pressure** means the total actual pressure within a given volume or system, above the absolute zero of pressure. Absolute pressure in a vacuum is equal to atmospheric pressure minus vacuum pressure.*
- 6 - When the absolute pressure reaches 23,000 microns (29.01 inches of mercury), close the manifold gauge valves, turn off the vacuum pump and disconnect the manifold gauge center port hose from vacuum pump. Attach the manifold center port hose to a nitrogen cylinder with pressure regulator set to 150 psig (1034 kPa) and purge the hose. Open the manifold gauge valves to break the vacuum in the line set and indoor unit. Close the manifold gauge valves.

CAUTION

Danger of Equipment Damage. Avoid deep vacuum operation. Do not use compressors to evacuate a system. Extremely low vacuums can cause internal arcing and compressor failure. Damage caused by deep vacuum operation will void warranty.

- 7 - Shut off the nitrogen cylinder and remove the manifold gauge hose from the cylinder. Open the manifold gauge valves to release the nitrogen from the line set and indoor unit.

- 8 - Reconnect the manifold gauge to the vacuum pump, turn the pump on, and continue to evacuate the line set and indoor unit until the absolute pressure does not rise above 500 microns (29.9 inches of mercury) within a 20-minute period after shutting off the vacuum pump and closing the manifold gauge valves.
- 9 - When the absolute pressure requirement above has been met, disconnect the manifold hose from the vacuum pump and connect it to an upright cylinder of HCFC-22 refrigerant. Open the manifold gauge valves to break the vacuum from 1 to 2 psig positive pressure in the line set and indoor unit. Close manifold gauge valves and shut off the HCFC-22 cylinder and remove the manifold gauge set.

C-Charging

The following procedures are intended as a general guide for use with expansion valve systems only. For best results, indoor temperature should be between 70 °F and 80 °F. Outdoor temperature should be 60 °F or above. Slight variations in charging temperature and pressure should be expected. Large variations may indicate a need for further servicing.

The outdoor unit should be charged during warm weather. However, applications arise in which charging must occur in the colder months. *The method of charging is determined by the unit's refrigerant metering device and the outdoor ambient temperature.*

Measure the liquid line temperature and the outdoor ambient temperature as outlined below:

- 1 - Connect the manifold gauge set to the service valves:
 - low pressure gauge to *vapor* valve service port
 - high pressure gauge to *liquid* valve service port
 Connect the center manifold hose to an upright cylinder of HCFC-22. Close manifold gauge set valves.
- 2 - Set the room thermostat to call for heat. This will create the necessary load for properly charging the system in the cooling cycle.
- 3 - Use a digital thermometer to record the outdoor ambient temperature.
- 4 - When the heating demand has been satisfied, switch the thermostat to cooling mode with a set point of 68°F (20°C). When pressures have stabilized, use a digital thermometer to record the liquid line temperature.
- 5 - The outdoor temperature will determine which charging method to use. Proceed with the appropriate charging procedure.

Weighing in the Charge Fixed Orifice or TXV Systems – Outdoor Temp < 65° F (18° C)

If the system is void of refrigerant, or if the outdoor ambient temperature is cool, the refrigerant charge should be weighed into the unit. Do this after any leaks have been repaired.

- 1 - Recover the refrigerant from the unit.
- 2 - Conduct a leak check, then evacuate as previously outlined.
- 3 - Weigh in the unit nameplate charge.

If weighing facilities are not available or if you are charging the unit during warm weather, follow one of the other procedures outlined below.

Approach and Normal Operating Pressures TXV Systems – Outdoor Temp. ≥ 65° F (18° C)

The following procedure is intended as a general guide and is for use on expansion valve systems only. For best results, indoor temperature should be 70°F (21°C) to 80°F (26°C). Monitor system pressures while charging.

- 1 - Record outdoor ambient temperature using a digital thermometer.
- 2 - Attach high pressure gauge set and operate unit for several minutes to allow system pressures to stabilize.
- 3 - Compare stabilized pressures with those provided in tables 10 and 11, "Normal Operating Pressures." Minor variations in these pressures may be expected due to differences in installations. Significant differences could mean that the system is not properly charged or that a problem exists with some component in the system. Pressures higher than those listed indicate that the system is overcharged. Pressures lower than those listed indicate that the system is undercharged. Verify adjusted charge using the approach method.
- 4 - Outdoor temperature should be 65°F (18°C) or above. Use the same digital thermometer used to check outdoor ambient temperature to check liquid line temperature. Verify the unit charge using the approach method. The difference between the ambient and liquid temperatures should match values given in table 3. Refrigerant must be added to lower approach temperature and removed to increase approach temperature. Loss of charge results in low capacity and efficiency.

- 5 - If the values don't agree with the those in tables 8 and 9, add refrigerant to lower the approach temperature or recover refrigerant from the system to increase the approach temperature.

TABLE 8

APPROACH METHOD - EXPANSION VALVE SYSTEMS	
Model	Liquid Line °F Warmer Than Outside (Ambient) Temperature
HS21-411/413	4±1
HS21-511/513	4±1
HS21-651/653	3±1

TABLE 9

APPROACH METHOD - EXPANSION VALVE SYSTEMS	
Model	Liquid Line °F Warmer Than Outside (Ambient) Temperature
HS21-036	7±1
HS21-048	7±1
HS21-060	8±1

- 4- When unit is properly charged liquid and suction line pressures should approximate those in tables 10 or 11.

! IMPORTANT

Use tables 10 or 11 as a general guide for performing maintenance checks. Tables 10 and 11 are not a procedure for charging the system. Minor variations in these pressures may be expected due to differences in installations. Significant deviations could mean that the system is not properly charged or that a problem exists with some component in the system. Used prudently, tables 10 and 11 could serve as a useful service guide.

TABLE 10

NORMAL OPERATING PRESSURES - HIGH SPEED OPERATION						
OUTDOOR COIL ENTERING AIR TEMPERATURE	HS21-410		HS21-510		HS21-650	
	LIQ. ± 10 PSIG	SUC. ± 10 PSIG	LIQ. ± 10 PSIG	SUC. ± 10 PSIG	LIQ. ± 10 PSIG	SUC. ± 10 PSIG
65° F (TXV)	149	72	160	73	138	69
75° F (TXV)	173	74	185	76	165	72
85° F (TXV)	202	76	220	78	192	74
95° F (TXV)	232	79	255	80	223	76
105° F (TXV)	265	81	285	82	257	78

TABLE 11

NORMAL OPERATING PRESSURES - HIGH SPEED OPERATION						
OUTDOOR COIL ENTERING AIR TEMPERATURE	HS21-036		HS21-048		HS21-060	
	LIQ. ± 10 PSIG	SUC. ± 10 PSIG	LIQ. ± 10 PSIG	SUC. ± 10 PSIG	LIQ. ± 10 PSIG	SUC. ± 10 PSIG
65° F (TXV)	149	72	142	72	142	70
75° F (TXV)	173	74	168	74	173	75
85° F (TXV)	202	76	196	76	202	77
95° F (TXV)	218	78	227	77	238	78
105° F (TXV)	265	79	260	79	267	80

D-Oil Charge

Factory oil charge in all HS21 series units is 70 fl. oz. Suniso 3GS.

VI-MAINTENANCE

! WARNING



Electric shock hazard. Can cause injury or death. Before attempting to perform any service or maintenance, turn the electrical power to unit OFF at disconnect switch(es). Unit may have multiple power supplies.

Maintenance and service must be performed by a qualified installer or service agency. At the beginning of each cooling season, the system should be checked as follows:

- 1 - Clean and inspect the outdoor coil. The coil may be flushed with a water hose. Ensure the power is turned off before you clean the coil.
- 2 - Condenser fan motor is prelubricated and sealed. No further lubrication is needed.
- 3 - Visually inspect connecting lines and coils for evidence of oil leaks.
- 4 - Check wiring for loose connections.
- 5 - Check for correct voltage at unit (unit operating).
- 6 - Check amp-draw condenser fan motor.
Unit nameplate _____ Actual _____ .

NOTE - If owner complains of insufficient cooling, the unit should be gauged and refrigerant charge checked. Refer to section on refrigerant charging in this instruction.

Indoor Coil

- 1 - Clean coil, if necessary.
- 2 - Check connecting lines and coils for evidence of oil leaks.
- 3 - Check the condensate line and clean it if necessary.

Indoor Unit

- 1 - Clean or change filters.
- 2 - Adjust blower speed for cooling. Measure the pressure drop over the coil to determine the correct blower CFM. Refer to the unit information service manual for pressure drop tables and procedure.
- 3 - *Belt Drive Blowers* - Check belt for wear and proper tension.
- 4 - Check all wiring for loose connections
- 5 - Check for correct voltage at unit (blower operating).
- 6 - Check amp-draw on blower motor
Unit nameplate _____ Actual _____ .

VII-Miscellaneous

If the fan orifice should ever need to be removed for service, make sure the control box seals watertight before placing the unit back in service. Figure 13 shows the components used to make the control box watertight. Two screws securing the

top of the control box to the cabinet must have rubber washers installed. Also, the control box must be installed with a foam-rubber weatherstrip installed along the top edge (between the control box and the cabinet).

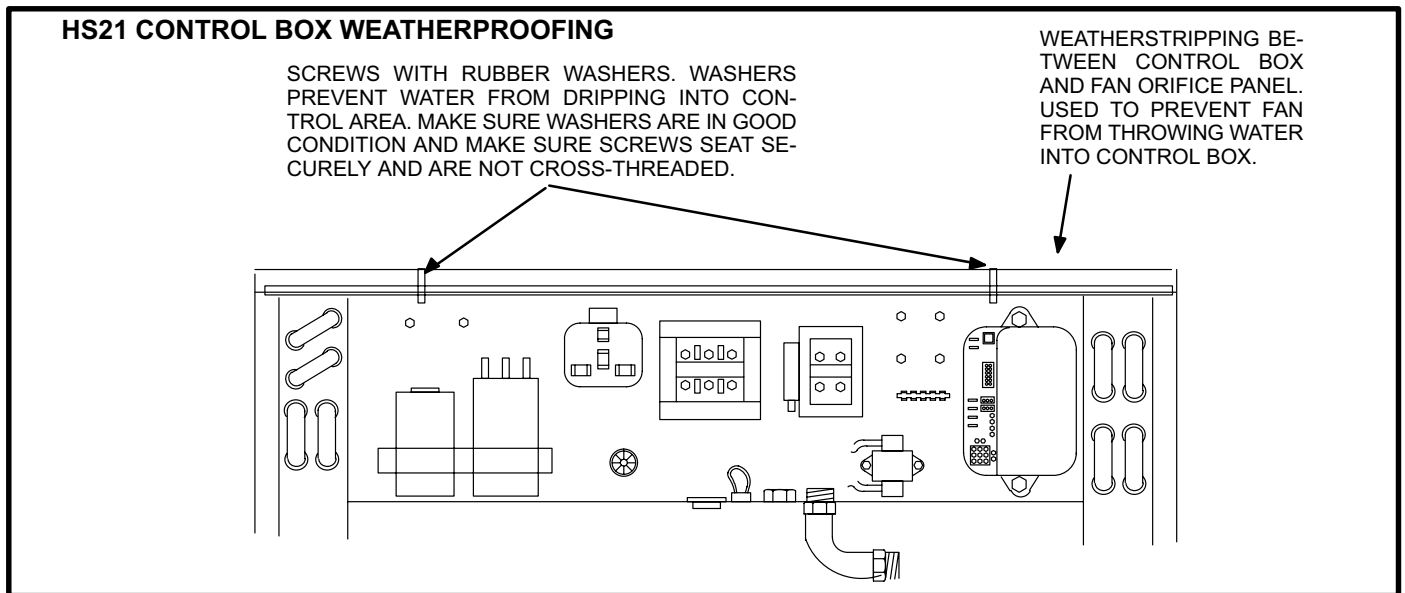

FIGURE 13

VIII-Operation Sequence - Compressor

Single-Phase Compressor Start-Up

Figure 14 shows single-phase compressor windings. This compressor has a two speed capacitor-start, capacitor-run motor. For starting, the start and run capacitors are in parallel to provide the proper starting torque. The start capacitor is disconnected by the start relay when the compressor comes up to speed. The run capacitor remains connected to the start winding and the motor runs as a two-phase induction motor with improved power factor and torque characteristics provided by the capacitor.

Low speed compressor operation is provided by powering the run windings (internally connected in series) from terminals 1 (common) and 7. The windings form a four-pole motor operating at 1800 RPM. The four low speed start windings are in series and are connected to terminals 1 (common) and 8. They are used with the start and run capacitors and start relay to start and bring the motor up to speed.

High speed compressor operation is provided when the run windings are connected in parallel; terminals 1 (common) and 7 to L1 and terminal 2 to L2. The windings form a two-pole motor operating at 3600 RPM. The two high speed start windings are in series and are connected to terminals 1 (common) and 3.

Three-Phase Compressor Start-Up

Figure 15 shows the windings of three-phase two-speed compressors. The compressors have two-speed, three-phase induction motors. Capacitors are not needed to provide the proper phase and torque characteristics.

Low speed operation is provided when the motor windings are connected in a series "Delta" circuit. The motor operates at 1800 RPM.

High speed operation is provided when the motor windings are connected in a parallel "Delta" circuit. Normally closed contacts on the low speed contactor provide this connection. The motor operates at 3600 RPM.

**SINGLE-PHASE MOTOR WINDINGS LOW SPEED
MOTOR LEAD TERMINALS**

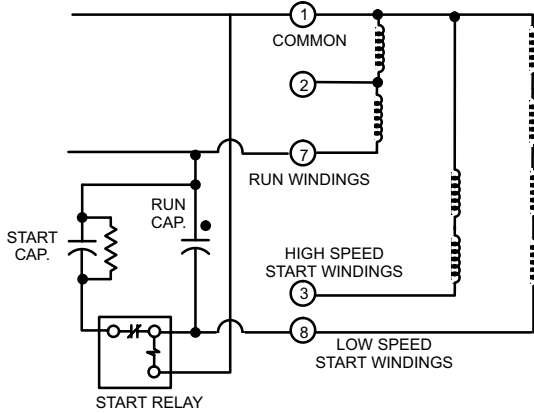

**SINGLE-PHASE MOTOR WINDINGS HIGH SPEED
MOTOR LEAD TERMINALS**

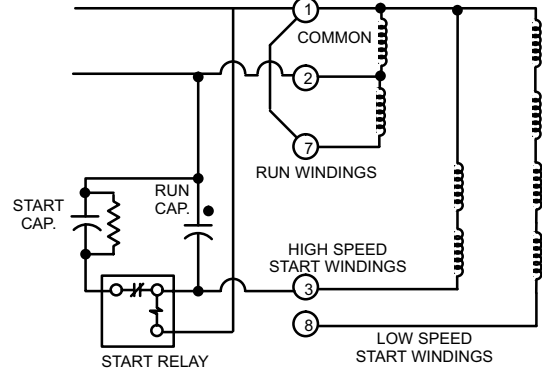
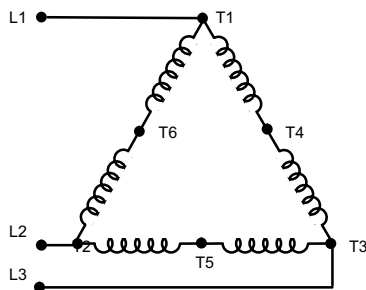

FIGURE 14

**THREE-PHASE MOTOR WINDINGS LOW SPEED
SERIES "DELTA" CIRCUIT**



**THREE-PHASE MOTOR WINDINGS HIGH SPEED
PARALLEL "DELTA" CIRCUIT**

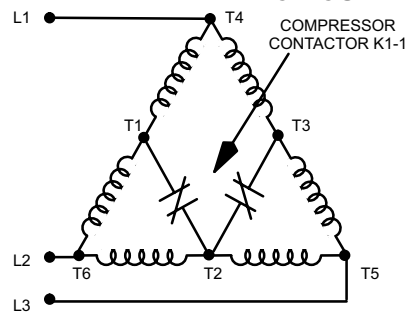
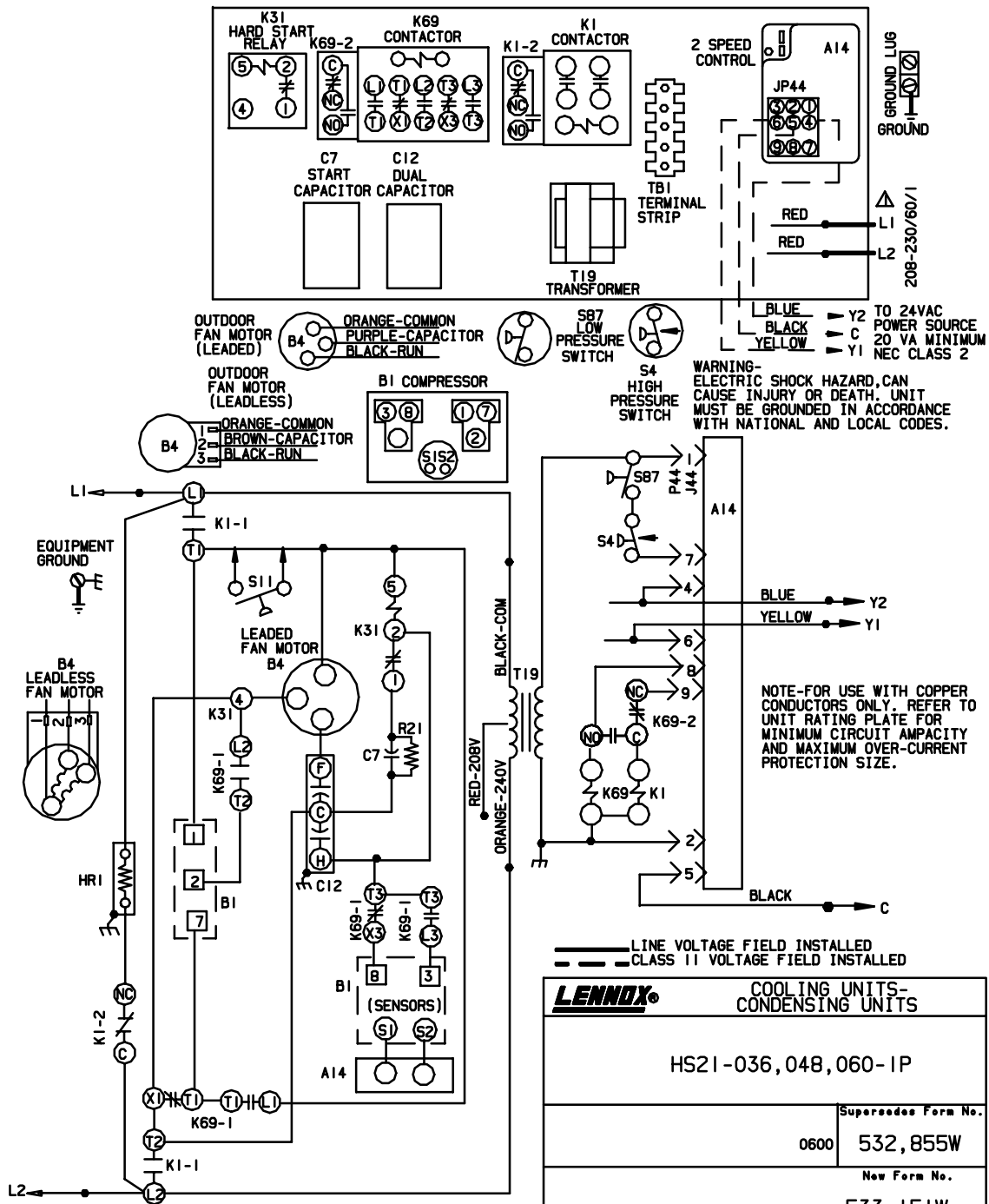

FIGURE 15

IX - WIRING DIAGRAMS AND SEQUENCE OF OPERATION

HS21 SINGLE PHASE -036, -048, 060



LENNOX®	
COOLING UNITS - CONDENSING UNITS	
HS21-036, 048, 060-1P	
0600	Supersedes Form No. 532, 855W
	New Form No. 533, 151W

©2000 Lennox Industries Inc.

Litho U.S.A.

HS21 SINGLE PHASE -411, -511, -651

Page 21

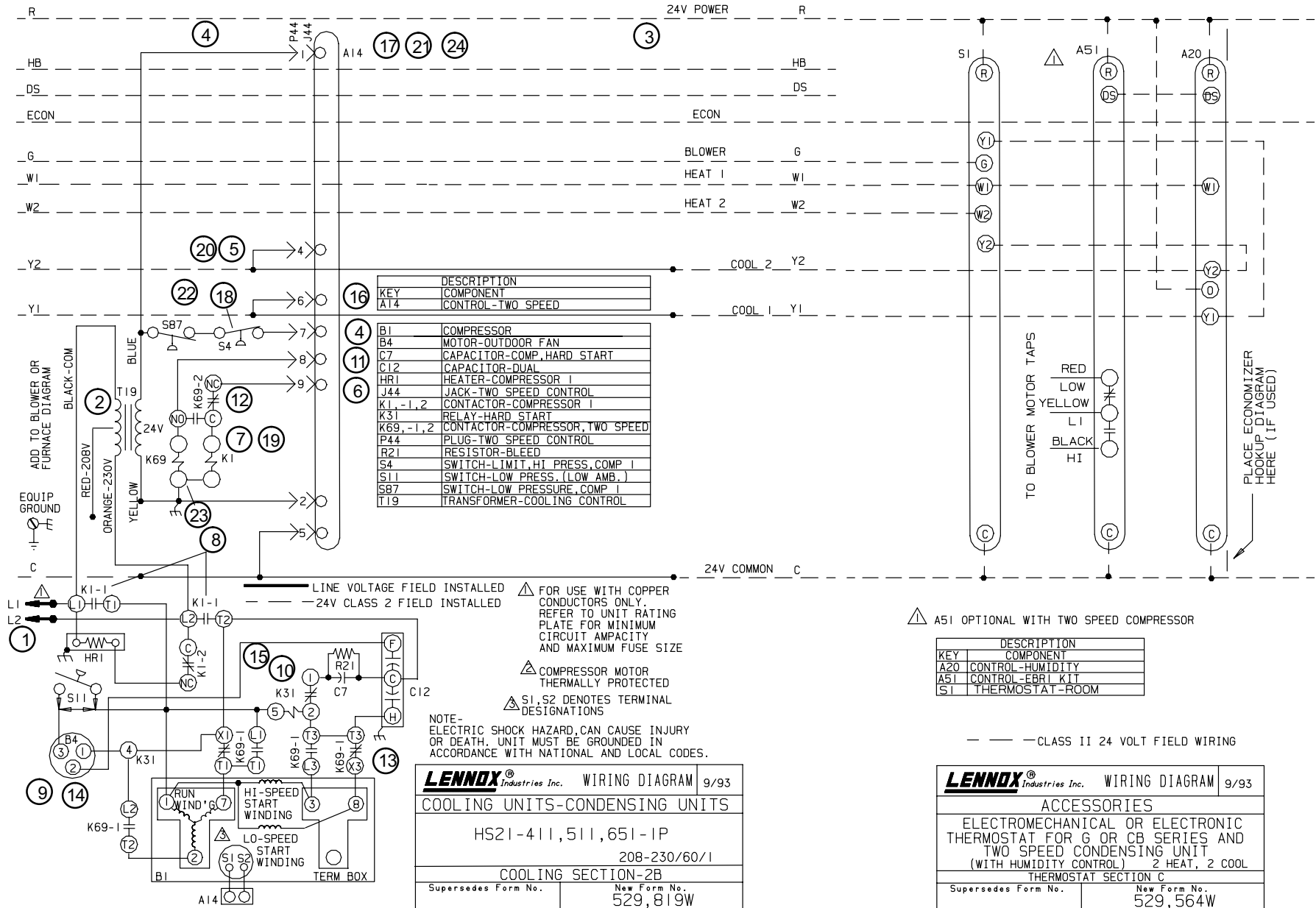

△ A51 OPTIONAL WITH TWO SPEED COMPRESSOR

KEY	DESCRIPTION
A20	CONTROL-HUMIDITY
A51	CONTROL-EBRI KIT
S1	THERMOSTAT-ROOM

--- CLASS II 24 VOLT FIELD WIRING

LENNOX Industries Inc. WIRING DIAGRAM 9/93
 COOLING UNITS-CONDENSING UNITS
 HS21-411, 511, 651-1P
 208-230/60/1
 COOLING SECTION-2B
 Supersedes Form No. _____ New Form No. 529,819W

LENNOX Industries Inc. WIRING DIAGRAM 9/93
 ACCESSORIES
 ELECTROMECHANICAL OR ELECTRONIC THERMOSTAT FOR G OR CB SERIES AND TWO SPEED CONDENSING UNIT (WITH HUMIDITY CONTROL) 2 HEAT, 2 COOL
 THERMOSTAT SECTION C
 Supersedes Form No. _____ New Form No. 529,564W

HS21 SINGLE PHASE UNITS

Electromechanical Thermostat Connected to HS21-411,511,651,036,048,060

SINGLE-PHASE STARTING SEQUENCE:

- 1- Line voltage feeds through L1 and L2 to energize outdoor transformer T19 and outdoor unit. Crankcase heater is energized through relay K1 auxiliary contacts.
- 2- Transformer T19 provides 24VAC to TSC (A14) and contactors K1 and K69.
- 3- The indoor transformer supplies 24VAC to the indoor unit and the indoor thermostat.
- 4- On power-up, 24VAC is fed through JP44-1 and JP44-7 to the TSC. The TSC begins a 10 second power-up delay.
- 5- The TSC begins a 5 minute delay during which the outdoor unit is not operational. After a 5 minute delay, the TSC waits in "OFF" mode for 1st stage or 2nd stage demand.

SINGLE-PHASE COMPRESSOR START-UP:

Low Speed

- 6- 1st stage demand: If all safety circuits check out, TSC energizes JP44-9.
- 7- Contactor K1 is energized through K69-2 N.C. contacts. K1-2 contacts open to de-energize the crankcase heater. All other K1 contacts close to start outdoor fan operation and to begin compressor low speed start-up.
- 8- Compressor B1 terminal 1 and the outdoor fan circuit are energized by K1 contacts L1-T1. Compressor terminal 7 is energized by contactor K1 terminal L2-T2 through contactor K69 terminal T1-X1. Compressor terminal 8 (start winding) is energized by contactor K1 terminal L2-T2 through the start (C7) and run (C5) capacitors and contactor K69 terminal T3-X3.
- 9- Outdoor fan B4 is energized when contactor K1 contacts L1-T1 and L2-T2 close.
- 10-As the compressor nears full speed, potential relay K31 energizes and K31 contacts open to de-energize the start capacitor.

High Speed

- 11-2nd stage demand: If all safety circuits check out, TSC energizes JP44-8.
- 12-Contactor K69 energizes and K69-2 auxiliary contacts close to energize contactor K1. K1-2 auxiliary contacts open to de-energize the crankcase heater. All other K1 contacts close. K69 contacts L1-T1, L2-T2 and L3-T3 close while contacts T1-X1 and T3-X3 open.
- 13-Compressor B1 terminal 3 (start winding) is energized by contactor K1 terminal L2-T2 through the start (C7) and the dual (C12) capacitors and through contactor K69 terminal L3-T3. Compressor terminal 2 is energized by contactor K1 terminal L2-T2, and contactor K69 terminal L2-T2. Compressor terminal 1 is energized directly by contactor K1 terminal L1-T1. Compressor terminal 7 is energized by contactor K1 terminal L1-T1 and through contactor K69 terminal L1-T1.

14-Outdoor fan B4 is energized when contactor K1 contacts L1-T1 and L2-T2 close.

15-As the compressor nears full speed, potential relay K31 energizes and K31 contacts open to de-energize start capacitor C7.

SINGLE-PHASE COOLING SEQUENCE:

16-1st stage cooling demand energizes TB15-Y1. TB15-Y1 energizes TSC terminal JP44-6.

NOTE-2nd stage cooling demand may be energized directly without passing through 1st stage.

17-TSC delays 3 seconds before responding to the new command.

18-If the unit is changing from 2nd stage to 1st stage demand, TSC initiates speed change delay and de-energizes JP44-8 and JP44-9 to stop all unit operation for 60±5 seconds. After TSC completes the 60±5 second speed change delay or if the unit is starting up in 1st stage directly from OFF mode, TSC checks safety circuits by looking for 24VAC at JP44-7 and by checking resistance through wires connected to S1 and S2.

19-If all safety circuits check out, TSC energizes K1 and compressor begins low speed start-up.

20-2nd stage cooling demand energizes TB15-Y1 and TB15-Y2. TB15-Y2 energizes TSC terminal JP44-4. TB15-Y1 energizes TSC terminal JP44-6.

21-TSC delays 3 seconds before responding.

22-If the unit is changing from 1st stage to 2nd stage demand, the TSC initiates speed change delay and de-energizes JP44-8 and JP44-9 to stop all unit operation for 60±5 seconds. After TSC completes the 60±5 second speed change delay or if the unit is starting up in 2nd stage directly from OFF mode, TSC checks safety circuits by looking for 24VAC at JP44-7 and by checking resistance through wires connected to S1 and S2.

23-If all safety circuits check out, TSC energizes K1 and K69. Compressor begins high speed start-up.

24-When thermostat demand is satisfied or if thermostat is switched OFF, all outdoor unit operation stops after a delay of 3 seconds. TSC then starts a 5 minute timed-off delay.

HS21 THREE PHASE -036, -048, -060

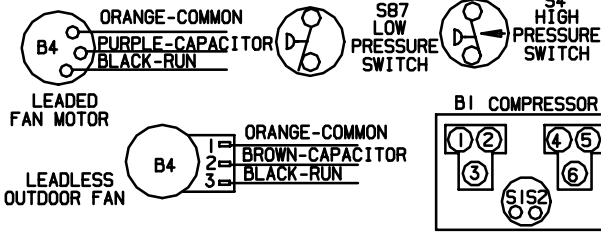
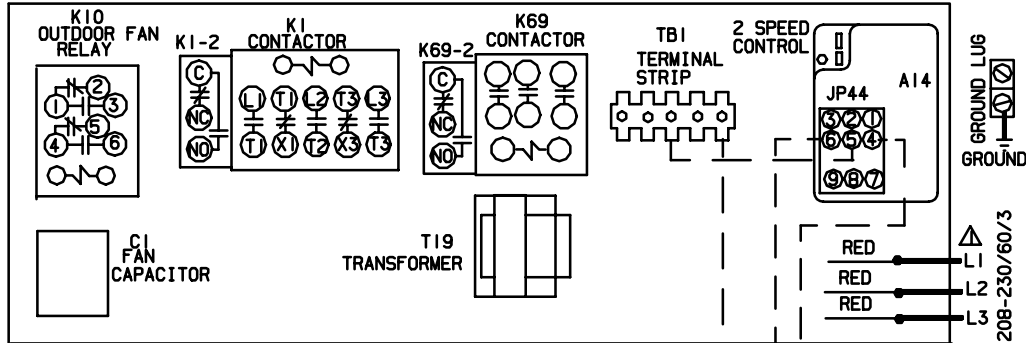

WARNING-
ELECTRIC SHOCK HAZARD, CAN
CAUSE INJURY OR DEATH. UNIT
MUST BE GROUNDED IN ACCORDANCE
WITH NATIONAL AND LOCAL CODES.

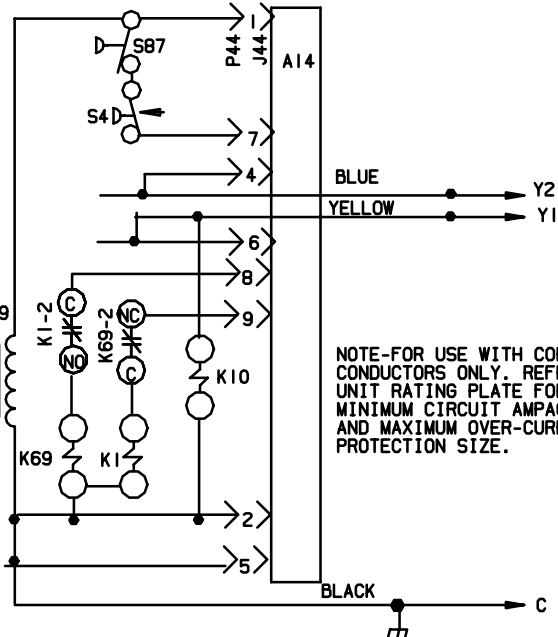
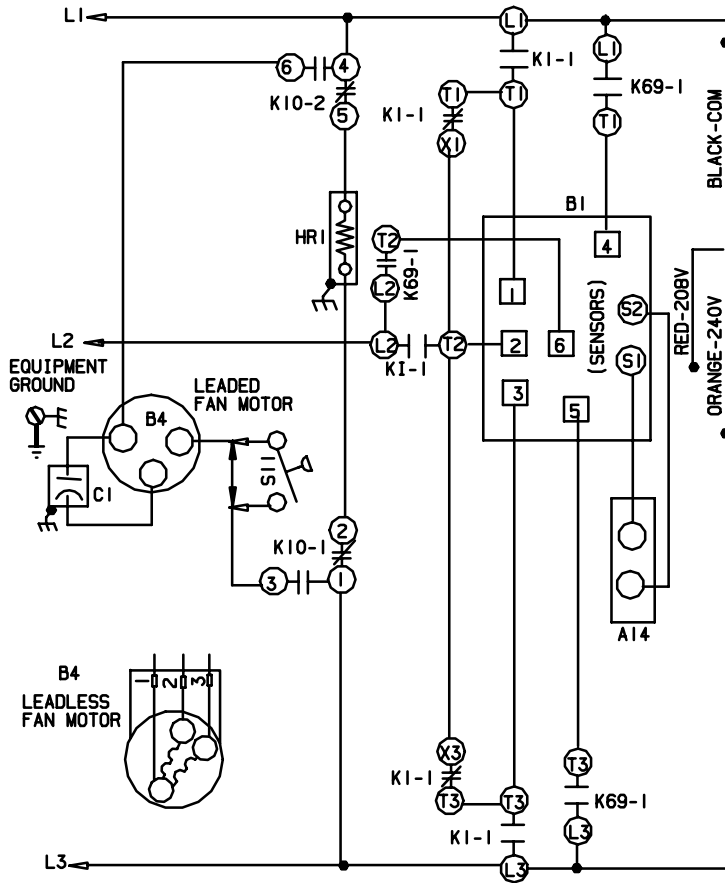

NOTE-FOR USE WITH COPPER
CONDUCTORS ONLY. REFER TO
UNIT RATING PLATE FOR
MINIMUM CIRCUIT AMPACITY
AND MAXIMUM OVER-CURRENT
PROTECTION SIZE.

— LINE VOLTAGE FIELD INSTALLED
- - - CLASS II VOLTAGE FIELD INSTALLED

LENNOX ®	
COOLING UNITS- CONDENSING UNITS	
HS21-036,048,060-1Y	
0600	Supersedes Form No. 532,856W
	New Form No. 533,152W

©2000 Lennox Industries Inc.

Litho U.S.A.

HS21 THREE PHASE -413, -513, -653

Page 24

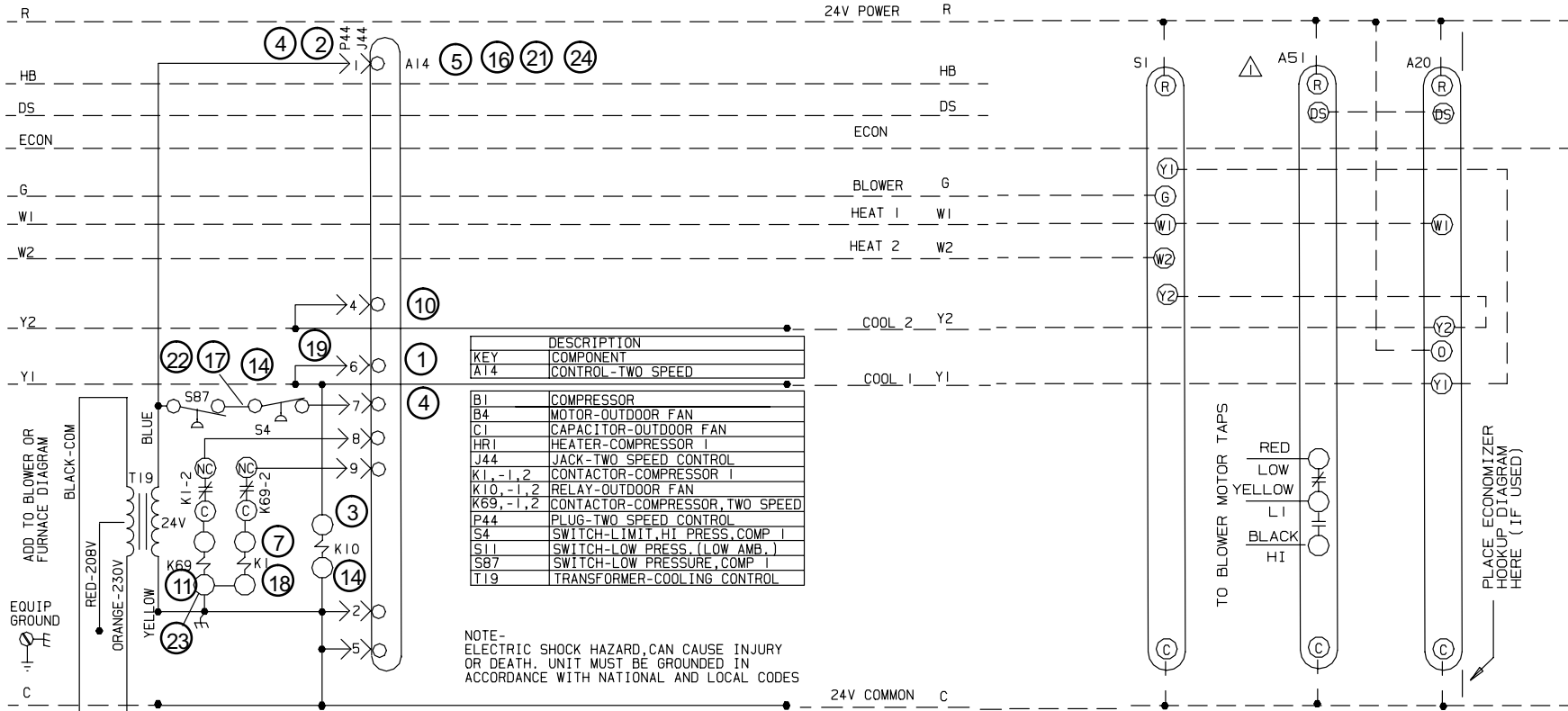

KEY	DESCRIPTION
A14	CONTROL-TWO SPEED
B1	COMPRESSOR
B4	MOTOR-OUTDOOR FAN
C1	CAPACITOR-OUTDOOR FAN
HRI	HEATER-COMPRESSOR 1
J44	JACK-TWO SPEED CONTROL
K1, -1, 2	CONTACTOR-COMPRESSOR 1
K10, -1, 2	RELAY-OUTDOOR FAN
K69, -1, 2	CONTACTOR-COMPRESSOR, TWO SPEED
P44	PLUG-TWO SPEED CONTROL
S4	SWITCH-LIMIT, HI PRESS, COMP 1
S11	SWITCH-LOW PRESS. (LOW AMB.)
S87	SWITCH-LOW PRESSURE, COMP 1
T19	TRANSFORMER-COOLING CONTROL

NOTE-
ELECTRIC SHOCK HAZARD, CAN CAUSE INJURY OR DEATH. UNIT MUST BE GROUNDED IN ACCORDANCE WITH NATIONAL AND LOCAL CODES

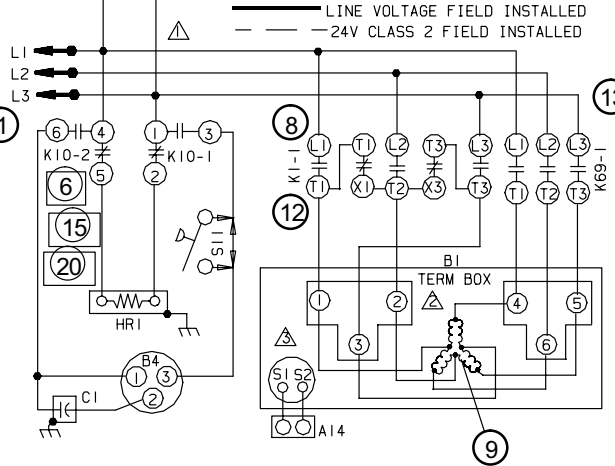
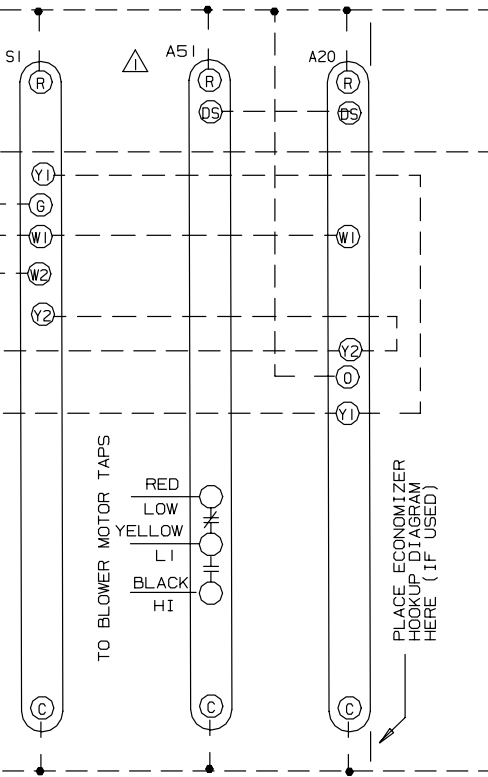

- ▲ FOR USE WITH COPPER CONDUCTORS ONLY. REFER TO UNIT RATING PLATE FOR MINIMUM CIRCUIT AMPACITY AND MAXIMUM FUSE SIZE
- ▲ COMPRESSOR MOTOR THERMALLY PROTECTED
- ▲ S1, S2 DENOTES TERMINAL DESIGNATIONS

▲ A51 OPTIONAL WITH TWO SPEED COMPRESSOR

KEY	DESCRIPTION
A20	CONTROL-HUMIDITY
A51	CONTROL-FBRI KIT
S1	THERMOSTAT-ROOM

--- CLASS II 24 VOLT FIELD WIRING

LENNOX Industries Inc. WIRING DIAGRAM 11/93
 COOLING UNITS-CONDENSING UNITS
 HS21-413, 513, 653-1Y
 COOLING SECTION-2B
 Supersedes Form No. _____ New Form No. 529, 820W
 ©1993 Lennox Industries Inc. Litho U.S.A.

LENNOX Industries Inc. WIRING DIAGRAM 9/93
 ACCESSORIES
 ELECTROMECHANICAL OR ELECTRONIC THERMOSTAT FOR G OR CB SERIES AND TWO SPEED CONDENSING UNIT (WITH HUMIDITY CONTROL) 2 HEAT, 2 COOL
 THERMOSTAT SECTION C
 Supersedes Form No. _____ New Form No. 529, 564W
 ©1993 Lennox Industries Inc. Litho U.S.A.

HS21 THREE PHASE UNITS

Electromechanical Thermostat Connected to HS21-413,513,653,036,048,060

THREE-PHASE STARTING SEQUENCE:

- 1- Line voltage feeds through L1, L2, and L3 to energize outdoor transformer T19 and outdoor unit. Crankcase heater is energized through relay K10-1 outdoor fan contacts.
- 2- Transformer T19 provides 24VAC to TSC (A14) and contactors K1 and K69.
- 3- The indoor transformer supplies 24VAC to the indoor unit, the indoor thermostat and the outdoor fan relay K10.
- 4- On power-up, 24VAC is fed through JP44-1 and JP44-7 to the TSC. The TSC begins a 10 second power-up delay.
- 5- The TSC begins a 5 minute delay during which the outdoor unit is not operational. After a 5 minute delay, the TSC waits in "OFF" mode for 1st stage or 2nd stage demand.

THREE-PHASE COMPRESSOR START-UP:

Low Speed

- 6- Low speed demand energizes outdoor fan relay K10 and JP44-6. K10-1 switches to energize the outdoor fan and de-energize the crankcase heater. Outdoor fan begins operating immediately.
- 7- After appropriate time delay and if all safety circuits check out, TSC energizes JP44-9. Contactor K1 is energized through K69-2 N.C. contacts.
- 8- K1 N.O. contacts close to begin compressor low speed start-up. K1 N.C. contacts open to disconnect the high speed wiring circuitry.
- 9- Compressor B1 terminal 1 is energized by K1 contacts L1-T1. Compressor terminal 2 is energized by contactor K1 terminal L2-T2. Compressor terminal 3 is energized by contactor K1 terminal L3-T3. This arrangement forms a series DELTA connection to the motor windings for low speed.

High Speed

- 10-High speed demand energizes JP44-4.
- 11-After appropriate time delay and if all safety circuits check out, TSC energizes JP44-8. Contactor K69 is energized through K1-2 N.C. contacts.
- 12-When contactor K1 is de-energized, contacts K1-1 normally closed contacts form a parallel DELTA connection to the motor windings for high speed.
- 13-N.O. K69-1 contacts close to begin compressor high speed start-up. Compressor terminal 4 is energized by contactor K69 terminal L1-T1. Compressor terminal 6 is energized by contactor K69 terminal L2-T2. Compressor terminal 5 is energized by contactor K69 terminal L3-T3.

THREE-PHASE COOLING SEQUENCE:

- 14-1st stage cooling demand energizes TB15-Y1. TB15-Y1 energizes TSC terminal JP44-6 and relay K10.

NOTE-2nd stage cooling demand may be energized directly without passing through 1st stage.

- 15-Relay contacts K10-1 switch to energize the outdoor fan and to de-energize the crankcase heater.
- 16-TSC delays 3 seconds before responding to the new command.
- 17-If the unit is changing from 2nd stage to 1st stage demand, TSC initiates speed change delay and de-energizes JP44-8 and JP44-9 to stop all unit operation for 60±5 seconds. Outdoor fan continues to operate. After TSC completes the 60±5 second speed change delay or if the unit is starting up in 1st stage directly from OFF mode, TSC checks safety circuits by looking for 24VAC at JP44-7 and by checking resistance through wires connected to S1 and S2.
- 18-If all safety circuits check out, TSC energizes K1 and compressor begins low speed start-up.
- 19-2nd stage cooling demand energizes TB15-Y1 and TB15-Y2. TB15-Y2 energizes TSC terminal JP44-4. TB15-Y1 energizes TSC terminal JP44-6 and outdoor fan relay K10.
- 20-Relay contacts K10-1 switch to energize the outdoor fan and to de-energize the crankcase heater.
- 21-TSC delays 3 seconds before responding.
- 22-If the unit is changing from 1st stage to 2nd stage demand, the TSC initiates speed change delay and de-energizes JP44-8 and JP44-9 to stop all unit operation for 60±5 seconds. After TSC completes the 60±5 second speed change delay or if the unit is starting up in 2nd stage directly from OFF mode, TSC checks safety circuits by looking for 24VAC at JP44-7 and by checking resistance through wires connected to S1 and S2.
- 23-If all safety circuits check out, TSC energizes K69. Compressor begins high speed start-up.
- 24-When thermostat demand is satisfied or if thermostat is switched OFF, all outdoor unit operation stops after a delay of 3 seconds. TSC then starts a 5 minute timed-off delay.

FIELD WIRING DIAGRAM HS21 WITH CB21

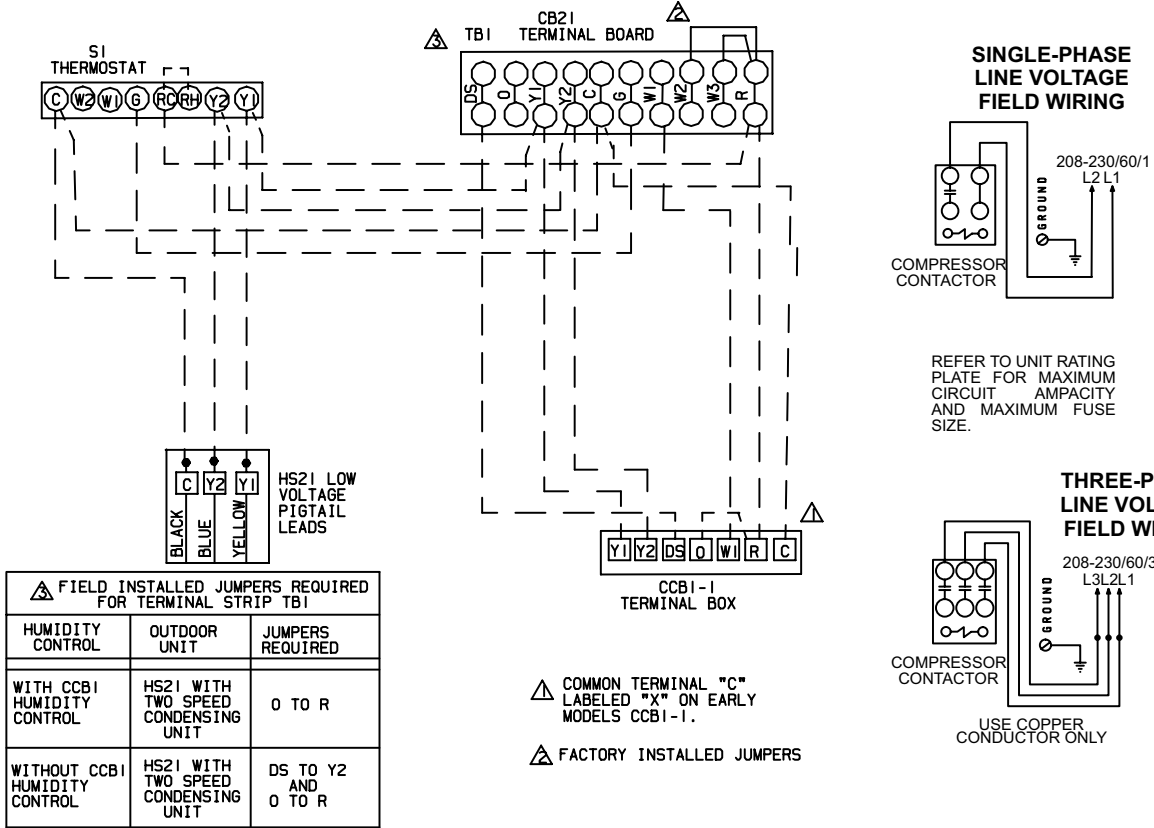

FIELD WIRING DIAGRAM HS21 WITH CB31MV

