

FG7S (D and M Series)

High Efficiency, Single Stage Condensing, Upflow/Horizontal and Downflow Gas Furnace Models

95.0 AFUE

38,000 - 120,000 Btuh Input

The high efficiency upflow gas furnace may be installed free standing in a utility room, basement, or enclosed in an alcove or closet. Upflow/horizontal units come ready for upflow or horizontal application. The extended flush jacket provides a pleasing "appliance appearance." Design certified by CSA for application in Canada and the United States.



WARRANTY

- 10-year all-parts warranty.
- 10 Year Quality Pledge to replace the unit if the heat exchanger fails within the first 10 years of operation, to the original owner.
- Consumer product registration required for 10 year All Parts Warranty and Quality Pledge within a limited period of time after the installation. See current warranty document or visit our consumer web site listed on the back of this document for warranty details.
- When registered, this product is upgraded to a limited lifetime heat exchanger warranty.

FEATURES and BENEFITS

- **100% fired and tested:** All units and each component are tested on the manufacturing line.
- **Best packaging in the industry:** Unique corner post design assures product will arrive to the homeowner dent free.
- **30 second blower delay** at start-up assures a warm duct temperature at furnace start-up. Adjustable blower off settings (60, 90, 120 and 180 seconds).
- **30 second post purge** increases life of heat exchanger.
- **Hot surface igniter:** Innovative application of a silicon nitride type igniter. Utilizes proven Smartlite® technology.
- **Color coded wire harness:** Designed to fit the components, all with quick-connect fittings for ease of service and replacement.
- **Flexible category IV venting system:** May be vertically or horizontally vented using either a one-pipe or two-pipe system for maximum flexibility in installation.
- **High Static Blowers:** All models equipped with high static blowers.
- **Low Boy Height:** Easy to apply in low ceiling applications, works well with taller high SEER coils, easier to handle and install.
- **Tubular primary heat exchanger:** Heavy gauge aluminized steel heat exchanger and stainless steel secondary heat exchanger assures a long life.
- **60 second fixed cooling cycle blower-off delay (TDR)** increases cooling performance when matched with a NORDYNE coil.
- **High efficiency blower kits** maximize efficiencies. On select units, a SEER improvement of up to 1 point is realized.
- **Multi-speed direct drive blower:** Designed to give a wide range of cooling capacities. Switches on PCB, provide ultra easy motor speed selection.
- **LP convertible:** Simple burner orifice and regulator spring change for ease of convertibility.
- **Diagnostic lights for easy troubleshooting without counting flashes:** Dedicated light for flame signal strength and 2 lights in combination to indicate all other fault codes with easy to recognize states without counting flashes.
- **Incorporates integrated control board** with connections for electronic air cleaner and humidifier.
- **Two piece door design** enhances furnace appearance and uses captured screws to prevent losing door screws.
- **Blower Compartment:** Sealed door to reduce air leakage and insulated for ultra quiet operation.
- **Sealed Vestibule** reduces burner and inducer sound levels.

GAS FURNACE COMPONENTS

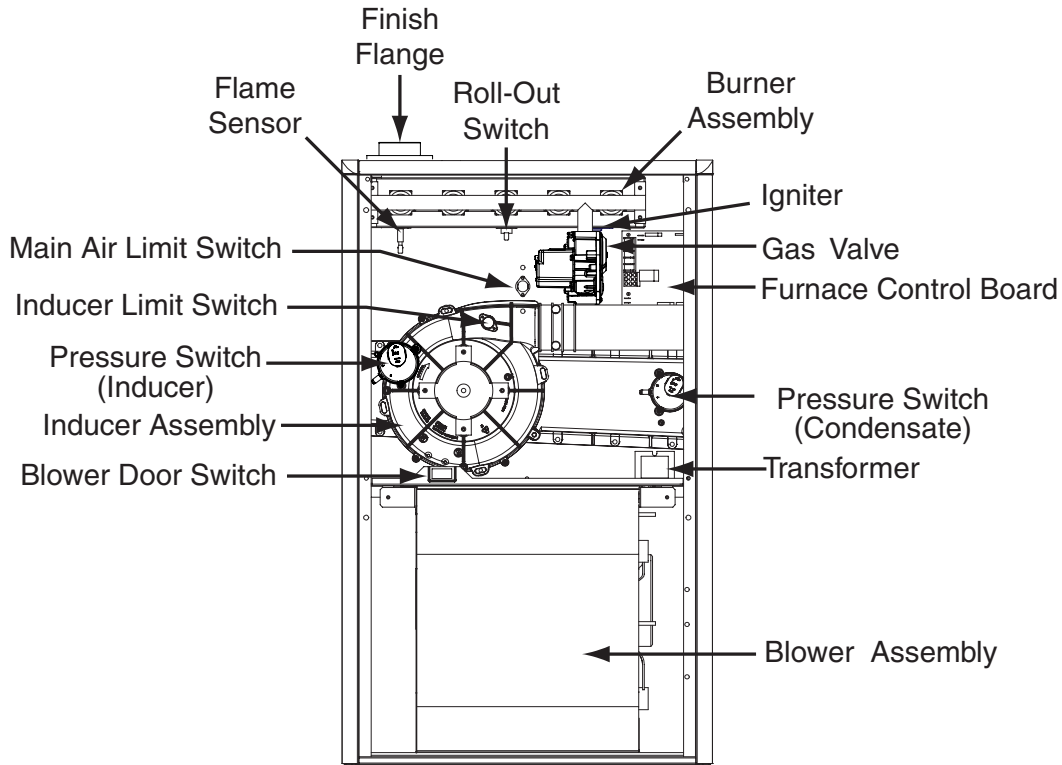

***SD Series -Upflow / Horizontal Furnace**

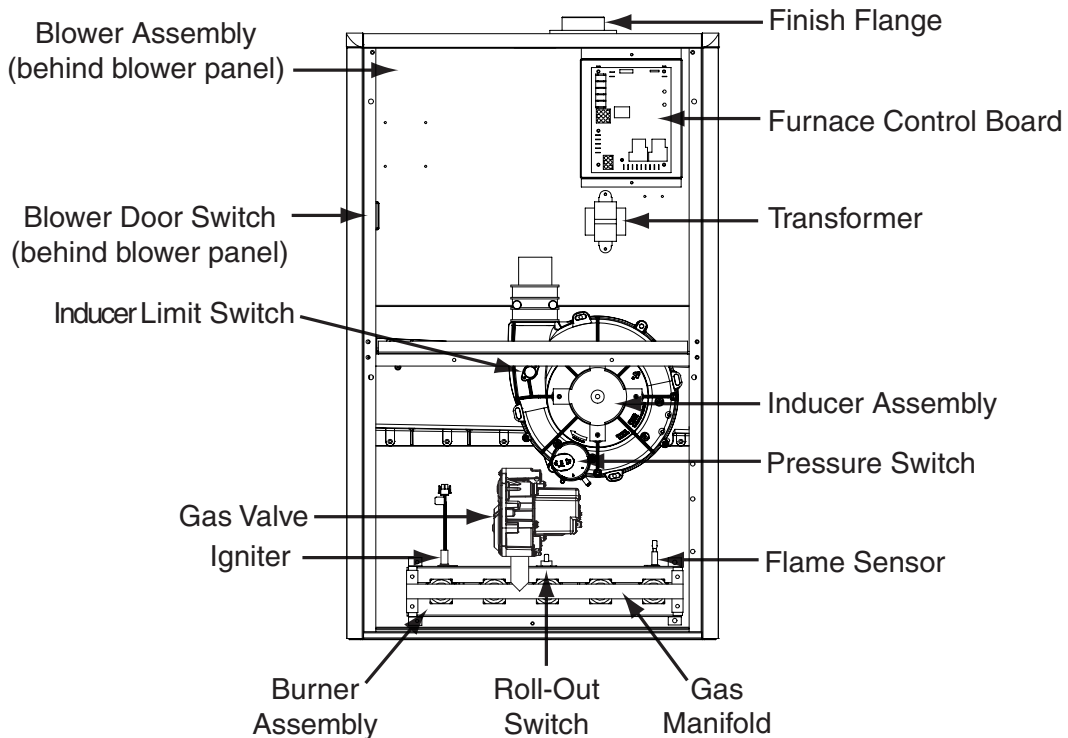

***SM Series Downflow Furnace**

DIMENSIONS

*SD Upflow / Horizontal Furnaces			
Model #'s	Dim. -A-	Dim -B-	Dim -C-
038D-24B	17 1/2	15 7/8	16 1/8
054D-24B			
072D-35C	21	19 3/8	19 5/8
090D-35C			
108D-45D	24 1/2	22 7/8	23 1/8
120D-45D			

NOTE: Dimensions shown in inches.

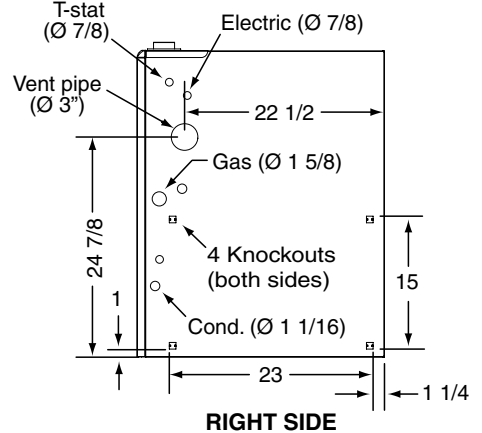
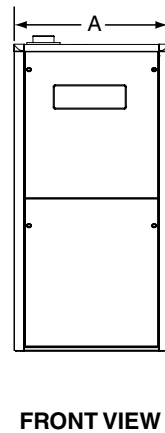
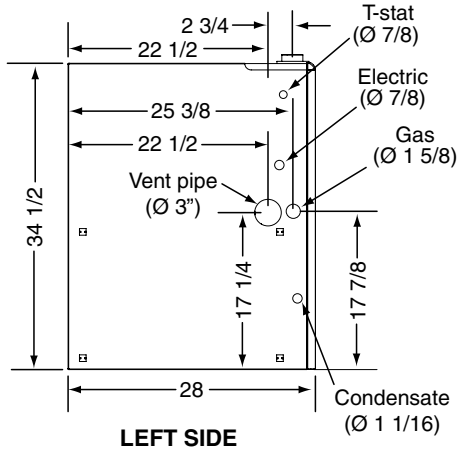
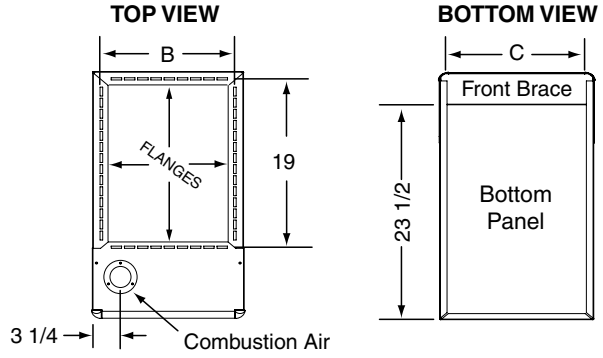

*SD Series -Upflow / Horizontal Furnace

*SM Downflow Furnaces			
Model #'s	Dim. -A-	Dim. -B-	Dim. -C-
054D24B	17 1/2	15 7/8	16 1/8
072D35C	21	19 3/8	19 5/8
090D35C			
118D45D	24 1/2	22 7/8	23 1/8

NOTE: Dimensions shown in inches.

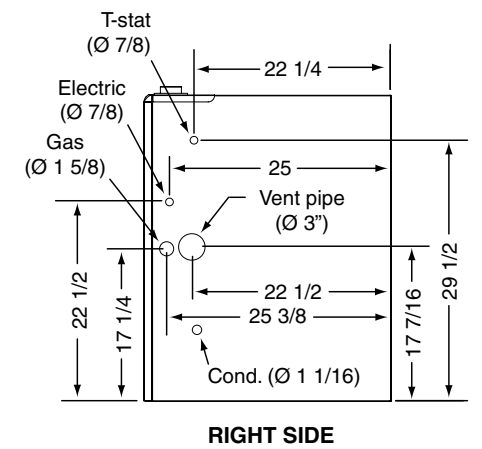
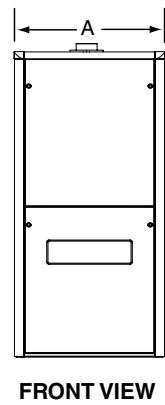
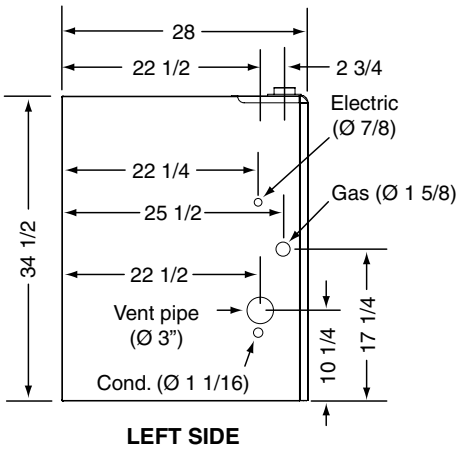
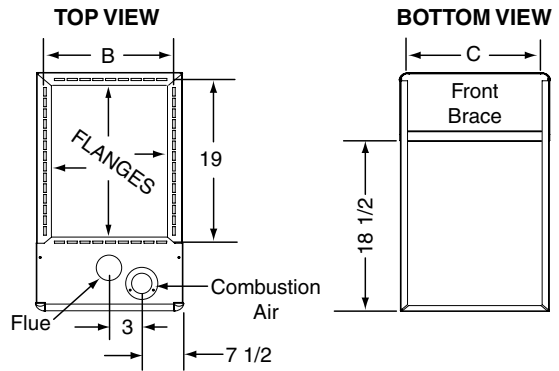

*SM Series Downflow Furnace

BLOWER PERFORMANCE - FG7SD

*SD - UPFLOW / HORIZONTAL FURNACES																	
Model Number & Heating Input (Btuh)	Motor Speed	External Static Pressure (Inches Water Column)															
		0.1		0.2		0.3		0.4		0.5		0.6		0.7		0.8	
		CFM	Rise	CFM	Rise	CFM	Rise	CFM	Rise	CFM	Rise	CFM	Rise	CFM	Rise	CFM	Rise
SD038D-24B Bottom Return (38,000)	HIGH*	1519	21	1483	22	1433	22	1397	23	1335	24	1272	25	1214	26	1130	27
	MED-H**	1238	28	1216	28	1188	28	1164	29	1136	30	1092	31	1043	32	973	34
	MED-L	1094	31	1082	32	1052	32	1034	33	1021	34	977	34	928	36	865	37
	LOW	841	40	817	42	801	43	786	45	750	46	720	48	683	49	639	53
SD038D-24B Side Return (38,000)	HIGH*	1664	18	1631	21	1596	21	1546	22	1489	23	1433	24	1366	25	1285	26
	MED-H	1272	26	1255	27	1249	27	1217	28	1189	29	1145	30	1096	31	1036	33
	MED-L**	1130	29	1114	31	1100	31	1079	31	1048	33	1025	33	987	35	944	36
	LOW	869	39	839	42	809	42	790	44	764	45	739	47	711	48	664	52
SD054D-24B Bottom Return (54,000)	HIGH*	1519	33	1483	34	1433	35	1397	36	1335	37	1272	39	1214	41	1130	44
	MED-H	1238	40	1216	41	1188	42	1164	43	1136	44	1092	46	1043	48	973	51
	MED-L**	1094	46	1082	46	1052	48	1034	48	1021	49	977	51	928	54	865	58
	LOW	841	59	817	61	801	62	786	64	750	67	720	69	683	73	639	78
SD054D-24B Side Return (54,000)	HIGH*	1664	30	1631	31	1596	31	1546	32	1489	34	1433	35	1366	37	1285	39
	MED-H	1272	39	1255	40	1249	40	1217	41	1189	42	1145	44	1096	46	1036	48
	MED-L**	1130	44	1114	45	1100	45	1079	46	1048	48	1025	49	987	51	944	53
	LOW	869	58	839	60	809	62	790	63	764	65	739	68	711	70	664	75
SD072D-35C Bottom Return (54,000)	HIGH*	1933	34	1857	36	1780	37	1695	39	1599	42	1498	45	1396	48	1280	52
	MED-H**	1872	36	1804	37	1731	39	1639	41	1551	43	1458	46	1353	49	1237	54
	MED-L	1320	51	1299	51	1264	53	1233	54	1183	56	1126	59	1059	63	963	69
	LOW	1185	56	1170	57	1132	59	1102	60	1067	62	1015	66	947	70	856	78
SD072D-35C Side Return (54,000)	HIGH*	1916	35	1848	36	1773	38	1692	39	1613	41	1515	44	1426	47	1316	51
	MED-H**	1815	37	1771	38	1711	39	1641	41	1553	43	1468	45	1373	49	1270	52
	MED-L	1259	53	1241	54	1224	54	1192	56	1163	57	1115	60	1056	63	982	68
	LOW	1139	59	1120	60	1096	61	1075	62	1047	64	1014	66	959	70	884	75
SCD72D-35C Side + Bottom or 2 Sides (72,000)	HIGH*	1954	34	1890	35	1824	37	1741	38	1656	40	1564	43	1470	45	1352	49
	MED-H**	1869	36	1805	37	1741	38	1685	40	1607	41	1516	44	1419	47	1308	51
	MED-L	1287	52	1262	53	1231	54	1197	56	1166	57	1117	60	1061	63	966	69
	LOW	1147	58	1115	60	1097	61	1075	62	1047	64	1014	66	959	70	884	75
SD090D-35C Bottom Return (90,000)	HIGH*	2288	36	2236	37	2161	39	2092	40	2017	41	1934	43	1841	45	1748	48
	MED-H**	2144	39	2093	40	2049	41	1985	42	1912	44	1842	45	1764	47	1668	50
	MED-L	1874	44	1845	45	1806	46	1766	47	1717	49	1661	50	1582	53	1503	55
	LOW	1541	54	1516	55	1509	55	1486	56	1456	57	1402	59	1361	61	1294	64
SD090D-35C Side Return (90,000)	HIGH*	2273	37	2222	38	2164	39	2098	40	2025	41	1947	43	1864	45	1780	47
	MED-H**	2084	40	2039	41	2007	42	1955	43	1895	44	1832	45	1750	48	1665	50
	MED-L	1784	47	1777	47	1749	48	1725	48	1679	50	1629	51	1576	53	1501	56
	LOW	1482	56	1470	57	1444	58	1432	58	1405	59	1375	61	1339	62	1286	65
SCD90D-35C Side + Bottom or 2 Sides (90,000)	HIGH*	2328	36	2273	37	2224	37	2151	39	2082	40	2005	42	1920	43	1825	46
	MED-H**	2124	39	2108	40	2052	41	2018	41	1954	43	1884	44	1813	46	1725	48
	MED-L	1825	46	1809	46	1781	47	1752	48	1706	49	1676	50	1615	52	1535	54
	LOW	1509	55	1488	56	1468	57	1440	58	1422	59	1379	60	1351	62	1292	64

BLOWER PERFORMANCE - FG7SD Continued

*SD - UPFLOW / HORIZONTAL FURNACES																	
Model Number & Heating Input (Btuh)	Motor Speed	External Static Pressure (Inches Water Column)															
		0.1		0.2		0.3		0.4		0.5		0.6		0.7		0.8	
		CFM	Rise	CFM	Rise	CFM	Rise	CFM	Rise	CFM	Rise	CFM	Rise	CFM	Rise	CFM	Rise
SD108D-45D Bottom Return (108,000)	HIGH*	2276	44	2228	45	2173	46	2108	47	2035	49	1961	51	1876	53	1778	56
	MED-H**	2113	47	2078	48	2019	50	1970	51	1904	53	1840	54	1768	57	1677	60
	MED-L	1819	55	1789	56	1757	57	1706	59	1666	60	1610	62	1551	64	1486	67
	LOW	1496	67	1484	67	1459	69	1430	70	1402	71	1363	73	1330	75	1262	79
SD108D-45D Side Return (108,000)	HIGH*	2306	43	2247	45	2192	46	2121	47	2044	49	1979	51	1892	53	1787	56
	MED-H**	2135	47	2103	50	2050	51	1995	53	1935	54	1858	57	1778	59	1690	62
	MED-L	1845	54	1834	57	1805	58	1776	59	1719	61	1663	63	1605	66	1533	69
	LOW	1543	65	1521	69	1502	70	1477	71	1452	73	1412	75	1368	77	1314	80
SD120D-45D Bottom Return (120,000)	HIGH*	2276	49	2228	50	2173	51	2108	53	2035	55	1961	57	1876	59	1778	62
	MED-H**	2113	53	2078	53	2019	55	1970	56	1904	58	1840	60	1768	63	1677	66
	MED-L	1819	61	1789	62	1757	63	1706	65	1666	67	1610	69	1551	72	1486	75
	LOW	1496	74	1484	75	1459	76	1430	78	1402	79	1363	82	1330	84	1262	88
SD120D-45D Side Return (120,000)	HIGH*	2306	48	2247	49	2192	51	2121	52	2044	54	1979	56	1892	59	1787	62
	MED-H**	2135	52	2103	53	2050	54	1995	56	1935	57	1858	60	1778	62	1690	66
	MED-L	1845	60	1834	61	1805	62	1776	63	1719	65	1663	67	1605	69	1533	72
	LOW	1543	72	1521	73	1502	74	1477	75	1452	77	1412	79	1368	81	1314	85

BLOWER PERFORMANCE - FG7SM

*SM - DOWNFLOW FURNACES																	
Model Number & Heating Input (Btuh)	Motor Speed	External Static Pressure (Inches Water Column)															
		0.1		0.2		0.3		0.4		0.5		0.6		0.7		0.8	
		CFM	Rise	CFM	Rise	CFM	Rise	CFM	Rise	CFM	Rise	CFM	Rise	CFM	Rise	CFM	Rise
SM054D-24B Top Return (54,000)	HIGH*	1590	31	1563	32	1538	33	1513	33	1477	34	1430	35	1370	36	1312	38
	MED-H	1228	41	1207	41	1193	42	1169	43	1157	43	1127	44	1084	46	1037	48
	MED-L**	1096	46	1079	46	1061	47	1038	48	1010	50	986	51	957	52	919	54
	LOW	855	58	825	61	800	63	777	64	753	66	723	69	696	72	665	75
SM072D-35C Top Return (72,000)	HIGH*	2235	30	2176	31	2121	31	2067	32	2010	33	1936	34	1864	36	1783	37
	MED-H**	2095	32	2052	32	2005	33	1957	34	1906	35	1852	36	1781	37	1709	39
	MED-L	1871	36	1838	36	1797	37	1761	38	1716	39	1667	40	1602	42	1536	43
	LOW	1568	43	1552	43	1527	44	1485	45	1457	46	1418	47	1370	49	1343	50
SM090D-35C Top Return (90,000)	HIGH*	2208	38	2150	39	2089	40	2026	41	1959	43	1893	44	1825	46	1738	48
	MED-H**	2065	40	2015	41	1970	42	1910	44	1866	45	1805	46	1737	48	1668	50
	MED-L	1802	46	1773	47	1750	48	1703	49	1670	50	1623	51	1556	54	1490	56
	LOW	1490	56	1482	56	1464	57	1436	58	1407	59	1380	60	1329	63	1271	66
SM118D-45D Top Return (118,000)	HIGH*	2358	46	2299	48	2253	48	2191	50	2130	51	2060	53	1990	55	1903	57
	MED-H**	2176	50	2135	51	2102	52	2046	53	1985	55	1932	57	1862	59	1777	61
	MED-L	1873	58	1852	59	1816	60	1790	61	1750	62	1699	64	1643	66	1571	70
	LOW	1544	71	1528	72	1514	72	1499	73	1462	75	1441	76	1429	76	1386	79

NOTES:

* Factory Set Cooling Speed

** Factory Set Heating Speed

- Two openings are recommended for airflows above 1,600 CFM if filter(s) is(are) adjacent to furnace
- Temperature rises in the table are approximate. Actual temperature rises may vary.
- Temperature rises shaded in gray are for reference only. These conditions are not recommended

VENTING

All models are approved for vertical non direct (1 pipe) and direct (2 pipe) venting applications. See Vent Table below for specified sizes and allowable lengths.

VENT TABLE

MODELS	SINGLE PIPE LENGTH (FT.) with 1 long radius elbow*		DIRECT VENT, DUEL PIPE LENGTH (ft.) WITH 1 long radius elbow on each pipe*	
	OUTLET	OUTLET	INLET/OUTLET	INLET/OUTLET
	2"	3"	2"	3"
SD038	50	70	50	70
SD054	70	90	70	90
SD072	50	90	50	90
SD090	60	90	60	90
SD108	N/A	90	N/A	90
SD120	N/A	90	N/A	90
SM054	70	90	70	90
SM072	50	90	50	90
SM090	60	90	60	90
SM118	N/A	90	N/A	90

* NOTE:

1. Subtract 2.5 ft. for each additional 2" elbow and 3.5 ft. for each additional 3" elbow.
2. Two 45 degree elbows are equivalent to one 90 degree elbow.
3. One short radius elbow is equivalent to two long radius elbows.
4. Do not include termination elbows in calculation of vent length.
5. This table is applicable for elevations from sea level to 2000 ft. For higher elevations decrease vent pipe lengths by 8% per 1000 ft. of altitude.
6. Only the listed pipe materials are approved for use with FG7 Condensing Furnaces.

MODEL IDENTIFICATION CODE

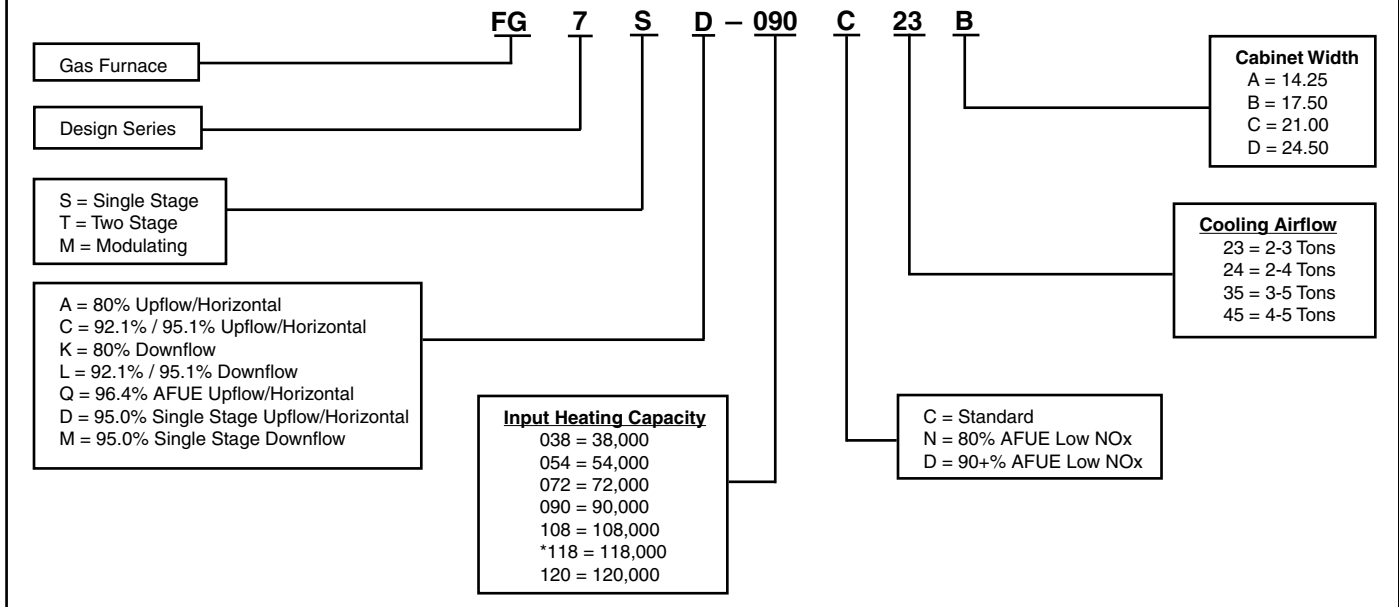

* 118 = 118,000 for SM Models

SPECIFICATIONS

FG7SD MODEL NUMBERS:	-038D-24B	-054D-24B	-072D-35C	-090D-35C	-108D-45D	-120D-45D
Input - Btuh (a)	38,000	54,000	72,000	90,000	108,000	120,000
Heating Capacity - Btuh	36,100	51,300	68,400	85,500	102,600	114,000
AFUE	95.0	95.0	95.0	95.0	95.0	95.0
Blower D x W	10 x 8	11 x 8	10 x 10	11 x 10	11 x 10	11 x 10
Motor H.P. - Speed - Type	1/2 - 4 - PSC	1/2 - 4 - PSC	1/2 - 4 - PSC	1 - 4 - PSC	1 - 4 - PSC	1 - 4 - PSC
Motor FLA	8.6	8.6	8.0	13.75	13.75	13.75
Rated Ext. SP - In. W.C.	0.5	0.5	0.5	0.5	0.5	0.5
Temperature Rise Range - °F	30-60	30-60	35-65	35-65	40-70	40-70
Shipping Weights	100lbs	120lbs	130lbs	135lbs	155lbs	155lbs

FG7SM MODEL NUMBERS:	-054D-24B	-072D-35C	-090D-35C	-118D-45D
Input - Btuh (a)	54,000	72,000	90,000	118,000
Heating Capacity - Btuh	51,300	68,400	85,500	112,100
AFUE	95.0	95.0	95.0	95.0
Blower D x W	11 x 8	11 x 10	11 x 10	11 x 10
Motor H.P. - Speed - Type	1/2 - 4 - PSC	1 - 4 - PSC	1 - 4 - PSC	1 - 4 - PSC
Motor FLA	8.6	13.7	13.7	13.75
Rated Ext. SP - In. W.C.	0.5	0.5	0.5	0.5
Temperature Rise Range - °F	30-60	35-65	35-65	40-70
Shipping Weights	120lbs	125lbs	135lbs	155lbs

Note: All models are 115V, 60 Hz. Gas Connections are 1/2" N.P.T. AFUE = Annual Fuel Utilization Efficiency
(a) Ratings to 2,000 ft. Over 2,000 ft. reduce 4% for each 1,000 ft. above sea level.

ACCESSORIES

FG7S (D, M) KITS	
Description	SKU
2" Concentric vent kit	904952
3" Concentric vent kit	904953
"B", "C", "D" Cabinet downflow sub base kit	904911
2" Side wall vent kit	904617
3" Side wall vent kit	904347
U.S. LP Conversion kit (0 to 10,000 ft.)	905028
Canada LP Conversion kit (0 to 4,500 ft.)	905029
Bottom return filter 20 per box, "B" cabinet	904916
Bottom return filter 20 per box, "C" cabinet	904917
Bottom return filter 20 per box, "D" cabinet	904918
Side return filter kit	541036
Neutralizer kit	902377
"A" Cabinet fixed speed, high efficiency, FSHE	904872
"B" Cabinet fixed speed, high efficiency, FSHE	904873
"C" Cabinet fixed speed, high efficiency, FSHE	904874
"D" Cabinet fixed speed, high efficiency, FSHE	904875
"A" Cabinet variable speed, high efficiency, VSHE	904876
"B" Cabinet variable speed, high efficiency, VSHE	904877
"C" Cabinet variable speed, high efficiency, VSHE	904878
"D" Cabinet variable speed, high efficiency, VSHE	904879



GENERAL TERMS OF LIMITED WARRANTY

NORDYNE will furnish a replacement for any part of this product which fails in normal use and service within the first ten years of installation, in accordance with the terms of the warranty.

For complete details of the Limited Warranty, including applicable terms and conditions, see your local installer or contact the NORDYNE warranty department for a copy.

NORDYNE
COMPLETE COMFORT. GENUINE VALUE.

8000 Phoenix Parkway | O'Fallon MO 63368-3827

Specifications and illustrations subject to change without notice and without incurring obligations. Printed in U.S.A (5/2012)

749D-0512 (Replaces 749D-0212)

www.westinghousevac.com

and Westinghouse are trademarks of Westinghouse Electric Corporation and used under license to NORDYNE.

© NORDYNE. All Rights Reserved.