

10
Inverter

Super Multi Zone Inverter Heat Pump

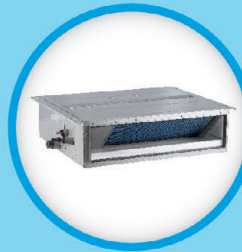

GREE+
SUPER

Multi-split System from 48,000-56,000BTU/h

Gree Super+MULTI is the latest generation of Multiple Inverter Air Conditioner, which is connectable up to 9 indoor units and offers rich choices of indoor units for different decoration requirement. With the GREE Inverter technology, the Super+MULTI can achieve a high energy efficient, steady operation, ultra comfort and low sound level to suit modern living environment.



Maximum 9 Indoor Unit Connections

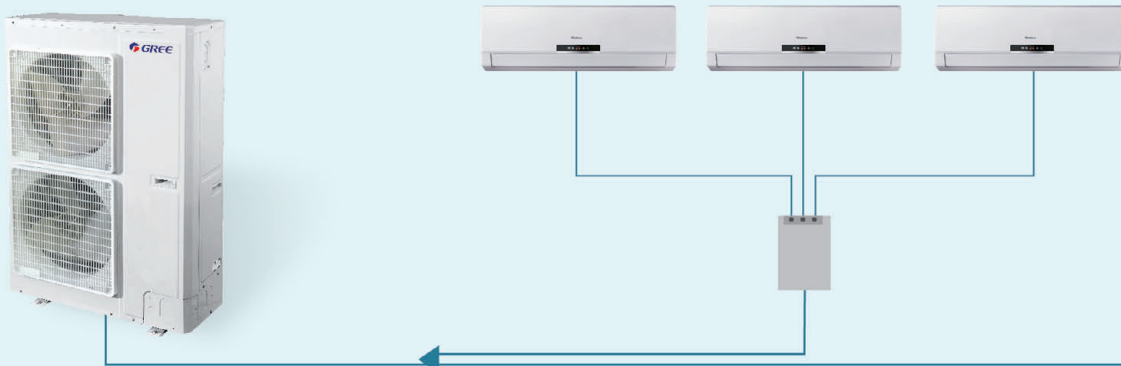

GREE Inverter Technology

Thanks to GREE Inverter technology, the unit operates with lower power consumption, lower noise and more comfort.

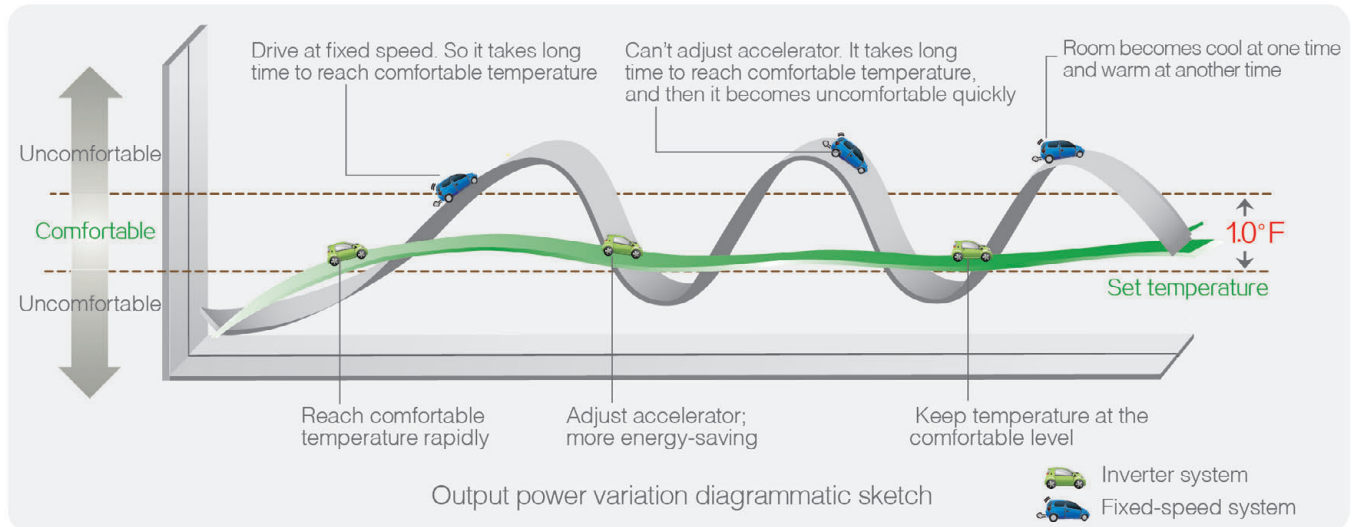

More Power Saving

GREE with advanced DC inverter 180° vector control ensures the stable operation of the compressor and saves up to 20% power per year (compared with the normal air conditioner).

Highly Comfortable

The GREE intelligent inverter control delivers the required capacity, according to the load variation from 10% to 120% and maintain the room temperature within $\pm 1.0^{\circ}\text{F}$ of the set

Lower Noise

The technology also optimizes the electrical sine wave to the compressor and results in smoother motor rotation, so that it can weaken the compressor vibration and peak of pipe stress changes, and lower the noise.



Optimized System Design



- ① Compressor
- ② Fan and Motor
- ③ Oil Separator
- ④ Components and Pipeline
- ⑤ Heat Exchanger
- ⑥ Electrical Box
- ⑦ Built-in Debugger
- ⑧ Service Port
- ⑨ Flexible Piping Connection

Compressor

The High Efficiency NRER (Non-Rare Earth Reluctance) Dual-rotor Inverter Compressor can fully utilize the reluctance torque of the motor for higher torque output that the efficiency can be increase by 5% with same output capacity and the performance of anti-demagnetization is better under high temperature.

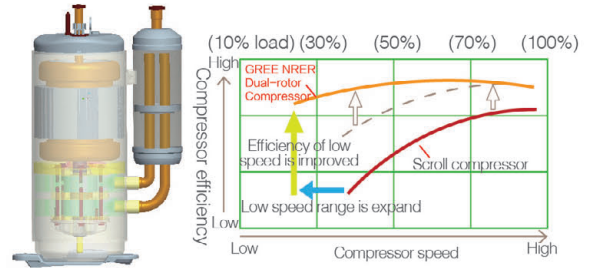
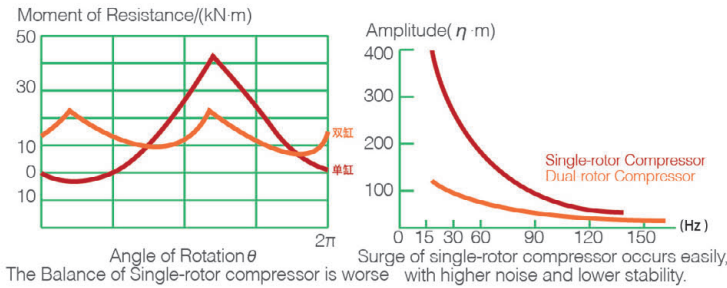

GREE Dual-rotor Compressor VS Single-rotor Compressor

Compared with the single-rotor compressor, the Dual-rotor compressor overcomes the weakness of the poor balancing performance, and noise & vibration is lower, stability of low frequency operation is better.

GREE Dual-rotor Compressor VS Scroll Compressor

Compared with scroll compressor, the size of dual-rotor compressor is smaller, the weight is only 60% of traditional scroll compressor, the operation frequency range is wider, and efficiency is higher.

Fan and Motor

• Optimized Fan

Optimized fan reduces the operation noise of the unit, providing comfortable indoor environment.

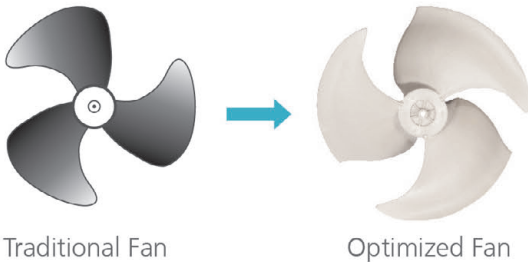

• High-efficiency DC Brushless Fan Motor

High-efficiency DC brushless fan motor offers greater efficiency and reduces operating noise,



Oil Separator

Adopting high efficient oil separator, of which maximum efficiency reaches to 99%, with Intelligent Oil return operation, system will automatically recover the chilled oil efficiently to ensure lubrication of the compressor.



Efficient oil separator

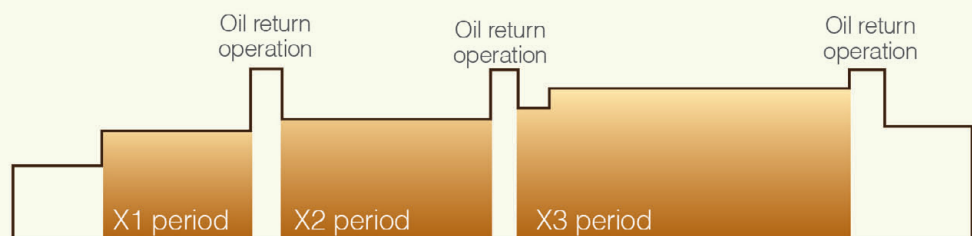

Optimized System Design

Components and Pipeline

In order to further reduce the discordant noise due to the operation of components, dynamic simulation of product component is conducted. The 3-D simulation of damping design for the pipelines has efficiently eliminated the hydrodynamic noise of refrigerant and ensures the quite operation of the system.



Heat Exchanger

• High Efficiency Inner-grooved Copper Tube

Heat exchanging performance is increased with high efficiency inner-grooved design.



• Slit Type Fin with Anti-corrosion Coating

The slit type fin enlarges heat exchange area significantly by 5%, meanwhile the anti-corrosive performance in salt-spray testing is 200%~300% higher than conventional.

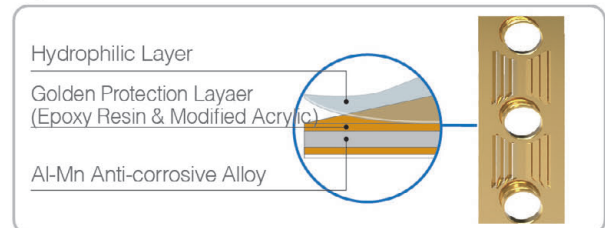

• New "2-1" Pass

The new "2-1" high efficiency heat exchanger design increased the exchanging effect and reducing the refrigerant pressure, system reliability is higher.

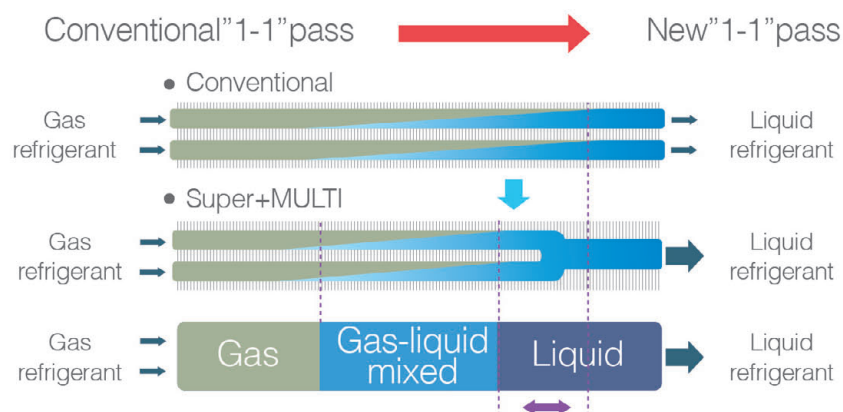

Electrical Box

New electrical box, design with quick debugger, easier for testing, commissioning and maintenance.

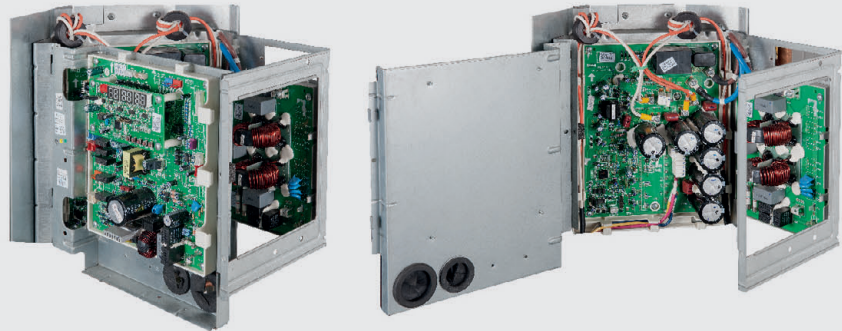

Built-in Debugger

Unique design with built in debugger, convenient for commissioning.

- Automatically detect indoor unit numbers.
- Automatically assign indoor unit addresses.
- Automatically display real running function and error code.
- Option settings to suit the demand of the customer.
- Remember and look up history running data.

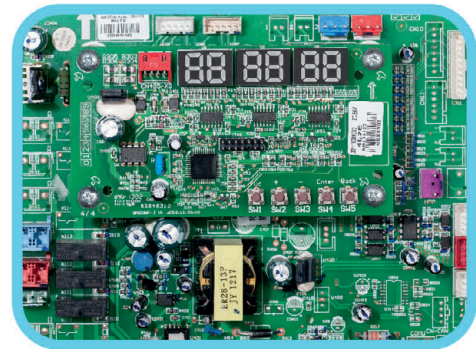

Service Port

Special service port for easier pressure detection and maintenance.

- Detect the high pressure at cooling mode.
- Detect the low pressure at heating mode.
- Charge additional refrigerant.

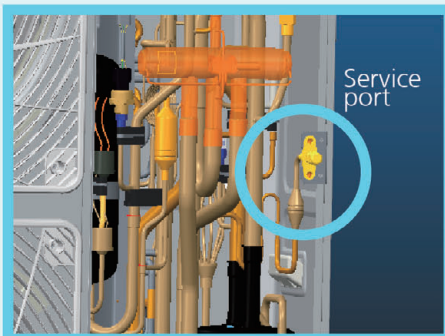

Flexible Piping Connection

The gas and liquid stop valves can be attached from different directions for seamless installation.

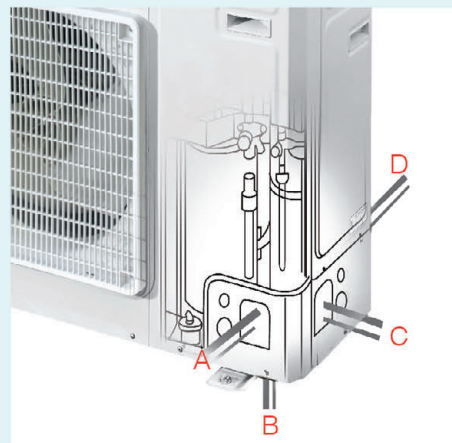

Flexible Piping Work with BU Module

The Super+MULTI introduces the BU (Branching Unit) module to simplify the piping work, so that the refrigerant piping is easier in handling and connecting, installation time and materials can be significantly reduced.



- Quick & Safe

By using flared connection, the installation is easier with less welding, higher safety and reliable.

- Comfort & Quite

The BU module can calculate cool and heat loads and precisely distribute refrigerant to each room. EXV built-in BU module allows a comfortable silence for living.

- Convenient Service

Quickly check refrigerant leak point; the welding points are less so once there is refrigerant leak, the leak point can be quickly found.

- Y-Joint Connection

Quickly check refrigerant leak point; the welding points are less so once there is refrigerant leak, the leak point can be quickly found.

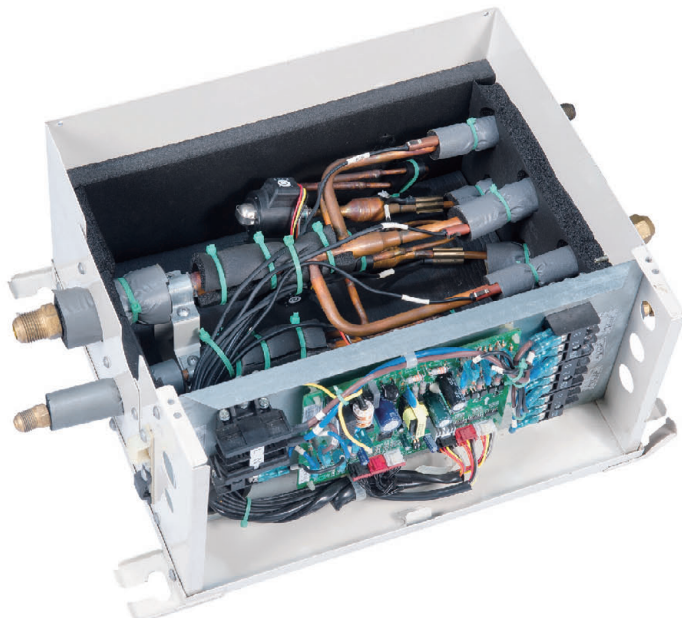

Liquid pipe



Gas pipe

Super Cooling Technology

65 °F of super cooling is achieved by exactly control of EXVs and real-time detection of the temperature sensors, so that the max total piping length can reach to 475ft, which is 98ft longer than conventional product, and capacity decreasing less than 10% under 328ft total piping length.

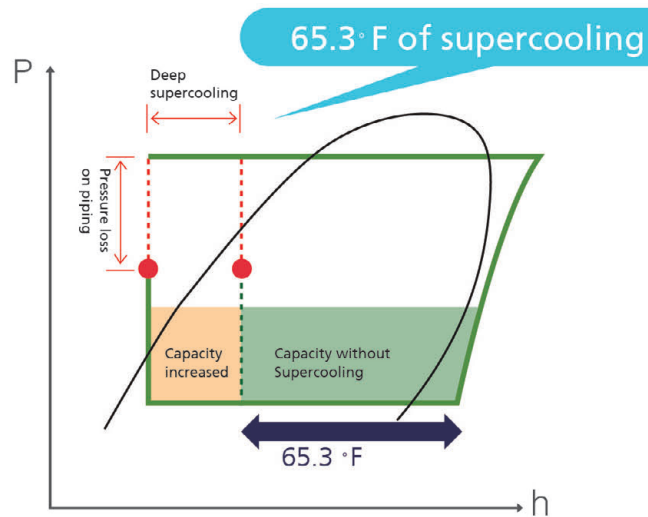

Flexible Piping Installation

- Total pipe length $\leq 475\text{ft}$
- Total pipe length between outdoor unit and BU $\leq 180\text{ft}$
- Total pipe length between BU and indoor unit $\leq 295\text{ft}$
- Piping length between the farthest indoor unit and the outdoor units $\leq 230\text{ft}$
- Pipe length between BU and indoor unit $\leq 49\text{ft}$
- Different in height between outdoor unit and indoor unit $\leq 98\text{ft}$

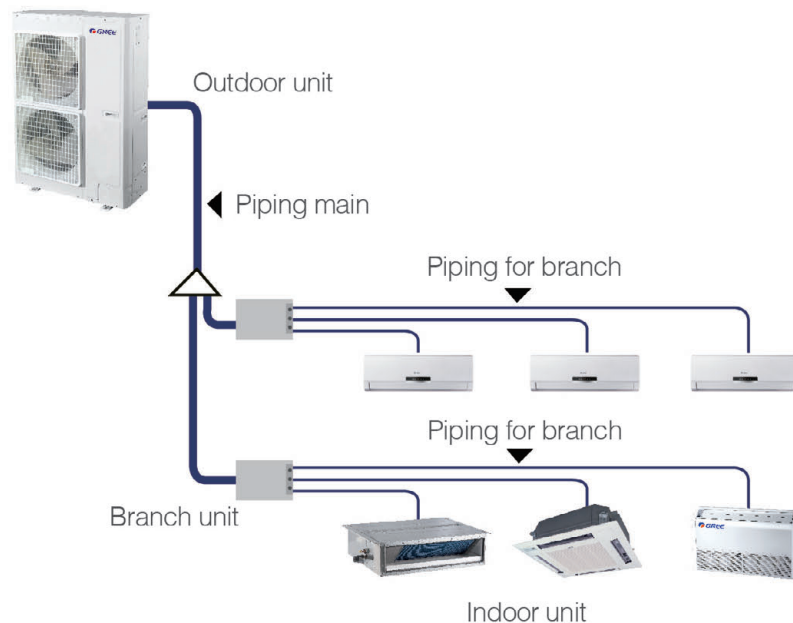

Wide Range of Outdoor and Indoor Unit

With various types of indoor unit and wide range of outdoor units, the Super+MULTI can satisfy both residential and commercial air conditioning requirements, such as villas, apartments, offices, shops, etc. It is not only an air conditioner but also a perfect indoor decoration.

Outdoor unit

2 models

48K Btu、56K Btu

There are 2 models outdoor unit for precise power to suit the size of house, offices of shops.

1-Phase model:
MULTI48HP230V1A
MULTI56HP230V1A



Outdoor Unit





Outdoor Unit HP Inverter			MULTI48HP230V1AO	MULTI56HP230V1AO
Cooling Capacity (Min-Max)	Btu/h		47,800(3,412-54,592)	52,900(3,412-61,416)
Heating Capacity (Min-Max)	Btu/h		54,600(4,094-59,369)	61,400(4,094-63,122)
Power Supply	V/Hz		208~230V/60Hz	208~230V/60Hz
Rated Current (A) Cooling	amps		23	25
Rated Current (A) Heating	amps		20	23
Operation Range - Cooling	deg F		5-118	5-118
Operation Range - Heating	deg F		-4~75	-4~75
Sound Pressure Level	db (A)		57	57
Max # Indoor Units			8	9
Refrigerant			R410A	R410A
Connecting pipe diameter	Gas/Suction	inch	φ5/8	φ5/8
	Liquid	inch	φ3/8	φ3/8
Max. Total Piping Length (Ft.)	feet		476	476
Max. Equivalent Length (Outdoor to last Indoor)	feet		230	230
Max. Elevation (Outdoor to Indoor Unit)	feet		99	99
Unit Dimension (WxHxD)	inch		35x53x15	35x53x15
Package Dimension (WxHxD)	inch		35x53x15	39x55x18
Net / Gross Weight	lb		256/276	256/276

BU Module

BU Port Expander Modules			RFX12A	RFX13A
No. of IDU can connected			2	3
Power Supply	V/Hz		208~230V/60Hz	208~230V/60Hz
Rated Current	amps		3.15	3.15
Connection Method	-		Flare	Flare
Connecting pipe diameter (to IDU)	Gas/Suction	inch	φ3/8	φ3/8
	Liquid	inch	φ1/4	φ1/4
Connecting pipe diameter (to ODU)	Gas/Suction	inch	φ5/8	φ5/8
	Liquid	inch	φ3/8	φ3/8
Maximum connect IDU NO.	-		2	3
Max. Equivalent Length (BU unit to Last Indoor)	feet		60	60
Unit Dimension (WxHxD)	inch		20.9 x 12.3 x 7.2	20.9 x 12.3 x 7.2
Package Dimension (WxHxD)	inch		27.0 x 15.5 x 10.6	27.0 x 15.5 x 10.6
Net weight/Gross weight	lbs		12/16	13/17

17 models 1 type

A wide range of indoor units includes 17 models in 1 type. Indoor unit can be selected to match each room and preference.

Capacity Index(BTU/h)			9000	12000	18000	24000
Wall mounted type	Neo		●	●	●	
Duct type			●	●	●	●
Cassette type				●	●	●
Floor ceiling type			●	●	●	●
Mini-Console type			●	●	●	

Control System Lineup

Controlling system	Product series	Wall mounted type	Duct type	Cassette type	Floor ceiling type	Console type
		Neo				
Wireless remote controller		●		●	●	●
Wired controller		●	●	●	●	

Note: ● means standard, ● means optional.

NEO WALL MOUNT



Wireless remote controller

Neo Wall Mount Units		NEO09HP230V1AH	NEO12HP230V1AH	NEO18HP230V1AH
Nominal Capacity - Cooling	Btu/h	9,000	12,000	18,000
Nominal Capacity - Heating	Btu/h	9,800	13,000	19,800
Power Supply	V/Hz	208-230V/60Hz	208-230V/60Hz	208-230V/60Hz
Running Current	amps	0.17	0.17	0.32
Airflow-T/H/M/L	CFM	306/277/253/218	335/277/253/218	500/459/383/324
SoundPressureLevel -T/H/M/L	db (A)	42/38/35/32	44/39/36/33	49/44/40/35
Connecting pipe diameter	Gas/Suction	inch	φ3/8	φ1/2
	Liquid	inch	φ1/4	φ1/4
Unit Dimension (WxHxD)	inch	33.3x10.8x7.1	33.3x10.8x7.1	37.0x11.7x7.9
PackageDimension (WxHxD)	inch	36.1x14.6x10.2	36.1x14.6x10.2	39.8x15.0x11.2
Net /GrossWeight	lbs	22/29	22/29	24/31

INDOOR UNIT

SLIM DUCT



Wired controller

Duct Indoor Unit		DUCT09HP230V1AD	DUCT12HP230V1AD	DUCT18HP230V1AD	DUCT24HP230V1AD
Nominal Capacity - Cooling	Btu/h	8,533	11,946	15,359	24,232
Nominal Capacity - Heating	Btu/h	9556	13,140	18,772	27,304
Power Supply	V/Hz	208/230V/60hz	208/230V/60hz	208/230V/60hz	208/230V/60hz
Airflow- T/H/M/L	CFM	265	294	412	588
Sound Pressure Level - T/H/M/L	db (A)	37/31	39/32	41/33	42/34
External Static Pressure Level	WG	Medium	Medium	Medium	Medium
Connecting pipe diameter	Gas/Suction	inch	φ3/8	φ3/8	φ1/2
	Liquid	inch	φ1/4	φ1/4	φ1/4
Unit Dimension (WxHxD)	inch	27.5x24.0x7.9	27.5x24.0x7.9	35.5x24.0x7.9	43.5x24.0x7.9
Package Dimension (WxHxD)	inch	35x29x12	35x29x12	44x29x12	52x29x12
Net / Gross Weight	lbs	48.5/60	51/64	60/79	68/90

CASSETTE



Wireless remote controller



Wired controller

Ceiling Cassette Indoor Unit		CAS12HP230V1AC	CAS18HP230V1AC	CAS24HP230V1AC
Nominal Capacity - Cooling	Btu/h	11,946	15,359	22,867
Nominal Capacity - Heating	Btu/h	13,652	17,065	27,304
Power Supply	V/Hz	1/208~230/60	1/208~230/60	1/208~230/60
Airflow- T/H/M/L	CFM	353	353	694
Sound Pressure Level - T/H/M/L	db (A)	46/44/42	46/44/42	39/37/35
Connecting pipe diameter	Gas/Suction	inch	φ3/8	φ1/2
	Liquid	inch	φ1/4	φ1/4
Unit Dimension (WxHxD)	inch	22.5x22.5x9.0	22.5x22.5x9.0	33.0x33.0x9.5
Package Dimension (WxHxD)	inch	33.5x29.0x13.0	33.5x29.0x13.0	38.0x38.0x13.0
Net / Gross Weight	lbs	40/51	40/51	62/77

Decorative Discharge Grille		CASGRILLE15M	CASGRILLE15M	CASGRILLE1LG
Unit Dimension (WxHxD)	inch	25.5x25.5x2.0	25.5x25.5x2.0	37.5x37.5x2.5
Package Dimension (WxHxD)	inch	29.0x26.5x4.5	29.0x26.5x4.5	4.0x40.5x5
Net / Gross Weight	lbs	6/8	6/8	7/10

FLOOR CEILING



Wired controller

Floor/Ceiling Indoor Unit			FLR09HP230V1AF	FLR12HP230V1AF	FLR18HP230V1AF	FLR24HP230V1AF
Nominal Capacity - Cooling	Btu/h		8,533	11,946	17,065	22,867
Nominal Capacity - Heating	Btu/h		9556	13,140	18,772	27,304
Power Supply	V/Hz		208/230V/60hz	208/230V/60hz	208/230V/60hz	208/230V/60hz
Airflow- T/H/M/L	CFM		382	382	559	736
Sound Pressure Level - T/H/M/L	db (A)		40/38/36	40/38/36	45/42/40	48/46/44
Connecting pipe diameter	Gas/Suction	inch	φ3/8	φ3/8	φ1/2	φ5/8
	Liquid	inch	φ1/4	φ1/4	φ1/4	φ3/8
Unit Dimension (WxHxD)	inch		48.0 x 27.5 x 9.0	48.0 x 27.5 x 9.0	48.0 x 27.5 x 9.0	48.0 x 27.5 x 9.0
Package Dimension (WxHxD)	inch		53 x 32 x 12.5	53 x 32 x 12.5	53 x 32 x 12.5	53 x 32 x 12.5
Net / Gross Weight	lbs		88/110	88/110	88/110	100/120

MINI-FLOOR CONSOLE



Wireless remote controller

Console Indoor Unit			CONS09HP230V1AF	CONS12HP230V1AF	CONS18HP230V1AF
Nominal Capacity - Cooling	Btu/h		8,874	11,946	18,089
Nominal Capacity - Heating	Btu/h		9,556	12,969	19,795
Power Supply	V/Hz		208/230V/60hz	208/230V/60hz	208/230V/60hz
Airflow- T/H/M/L	CFM		294	353	383
Sound Pressure Level - T/H/M/L	db (A)		40/38/36/33/30/27/25	42/40/38/37/35/32/27	48/46/44/41/37/35/32
Connecting pipe diameter	Gas/Suction	inch	φ3/8	φ3/8	φ1/2
	Liquid	inch	φ1/4	φ1/4	φ1/4
Unit Dimension (WxHxD)	inch		27.5 x 24.0 x 8.5	27.5 x 24.0 x 8.5	27.5 x 24.0 x 8.5
Package Dimension (WxHxD)	inch		31 x 28 x 11	31 x 28 x 11	31 x 28 x 11
Net / Gross Weight	lbs		33/40	33/40	33/40



GREE ELECTRIC APPLIANCES, INC. OF ZHUHAI

For more information, visit greecomfort.com

Specifications and appearance are subject to change without notice.
Copyright ©Gree Electric Appliances, Inc. of Zhuhai. All rights reserved.

GC-1410-1



Distributor information