

## DUCT FREE SPLIT SYSTEM HIGH WALL, R-410A

Efficient Up To 22 SEER Air Conditioners and  
10 HSPF Heat Pumps

### ¾ THRU 3 TONS

- Inverter driven compressors in all models
- Wireless remote standard for enhanced functionality
- Timer
- Sleep mode
- Diagnostics
- Auto-Swing louvers
- Compressor lockout protection
- 115 volt on ¾ and 1 ton models
- Factory charged with R-410A refrigerant
- Cooling low ambient control feature allows operation down to 5°F (-15°C) on size 12K - 30K, 230 volt models.
- 7 year limited compressor, 5 year limited coil and parts warranties



Use of the AHRI Certified TM Mark indicates a manufacturer's participation in the program. For verification of certification for individual products, go to [www.ahridirectory.org](http://www.ahridirectory.org).



Air Conditioners		
Outdoor Section	Size (tons)	Dimensions W x H x D in. (mm)
Indoor Section		
DLC4AV09J1A	¾	33.4 x 21.3 x 12.6 (848.4 x 541 x 320)
DLF4AH09J1A	¾	33.3 x 10.7 x 7.1 (846 x 272 x 180)
DLC4AV12J1A	1	33.4 x 21.3 x 12.6 (848.4 x 541 x 320)
DLF4AH12J1A	1	33.3 x 10.7 x 7.1 (846 x 272 x 180)
DLC4AV12K1A	1	33.4 x 23.2 x 12.6 (848.4 x 541 x 320)
DLF4AH12K1A	1	33.3 x 10.7 x 7.1 (846 x 272 x 180)
DLC4AV18K1B	1½	37.6 x 27.6 x 15.6 (955 x 701 x 396.2)
DLF4AH18K1A	1½	37 x 11.7 x 7.9 (940 x 297 x 201)
DLC4AV24K1A	2	38.6 x 31.1 x 16.8 (980.4 x 789.9 x 426.7)
DLF4AH24K1A	2	39.7 x 12.4 x 8.6 (1008 x 315 x 218)
DLC4AV36K1A	3	38.6 x 31.1 x 16.8 (980.4 x 789.9 x 426.7)
DLF4AH36K1A	3	53.1 x 12.8 x 10 (1349 x 325 x 254)
Heat Pumps		
Outdoor Section	Size (tons)	Dimensions W x H x D in. (mm)
Indoor Section		
DLC4HV09J1A	¾	33.4 x 21.3 x 12.6 (848.4 x 541 x 320)
DLF4HH09J1A	¾	33.3 x 10.7 x 7.1 (846 x 272 x 180)
DLC4HV12J1A	1	33.4 x 21.3 x 12.6 (848.4 x 541 x 320)
DLF4HH12J1A	1	33.3 x 10.7 x 7.1 (846 x 272 x 180)
DLC4HV12K1A	1	33.4 x 21.3 x 12.6 (848.4 x 541 x 320)
DLF4HH12K1A	1	33.3 x 10.7 x 7.1 (846 x 272 180)
DLC4HV18K1A	1½	37.6 x 27.6 x 15.6 (955 x 701 x 396.2)
DLF4HH18K1A	1½	37 x 11.7 x 7.9 (940 x 297 x 201)
DLC4HV24K1A	2	38.6 x 31.1 x 16.8 (980.4 x 789.9 x 426.7)
DLF4HH24K1A	2	39.7 x 12.4 x 8.6 (1008 x 315 x 218)
DLC4HV30K1A	2½	38.6 x 31.1 x 16.8 (980.4 x 789.9 x 426.7)
DLF4HH30K1A	2½	53.1 x 12.8 x 10 (1349 x 325 x 254)
DLC4HV36K1A	3	38.6 x 31.1 x 16.8 (980.4 x 789.9 x 426.7)
DLF4HH36K1A	3	53.1 x 12.8 x 10 (1349 x 325 x 254)

Note: W = Width includes service valve

**Required Clearances**

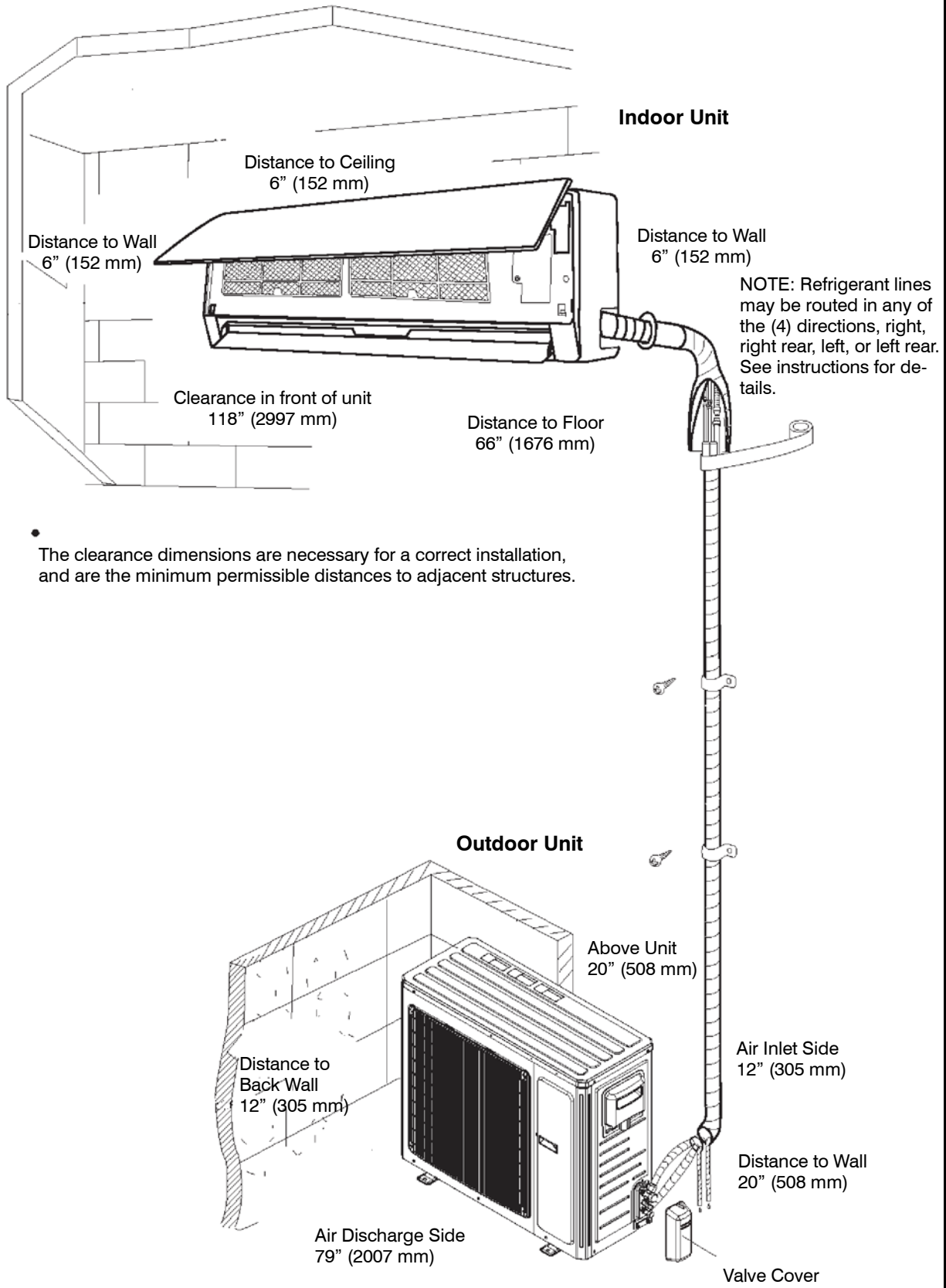

• The clearance dimensions are necessary for a correct installation, and are the minimum permissible distances to adjacent structures.

**Note:**

- If the outdoor unit is higher than the indoor unit, prevent rain from flowing into the indoor unit along the connection pipe by making a downward arc in the connection pipe before it enters the wall to the indoor unit. This will ensure that rain will drip from the connection pipe before it enters the wall.
- The illustration above is only a sketch. Different models may be slightly different.

## DIMENSIONS

### INDOOR

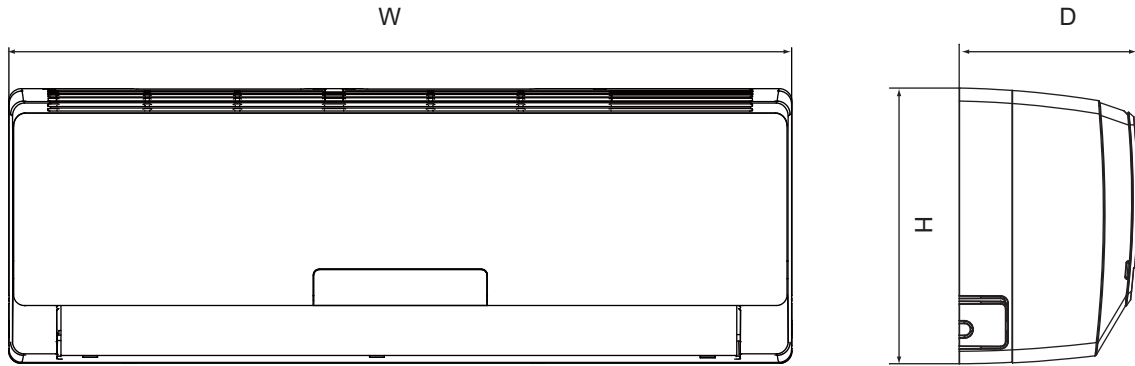

A12377

Unit Size	W In. (mm)	H In. (mm)	D In. (mm)	Net Operating Weight Lbs. (Kg)
9k	33.3 (846)	10.7 (272)	7.1 (180)	29 (13)
12k	33.3 (846)	10.7 (272)	7.1 (180)	29 (13)
18k	37.0 (940)	11.7 (297)	7.9 (201)	29 (13)
24k	39.7 (1008)	12.4 (315)	8.6 (218)	35 (16)
30k	53.1 (1349)	12.8 (325)	10.0 (54)	44.1 (20.0)
36k	53.1 (1349)	12.8 (325)	10.0 (54)	44.1 (20.0)

### OUTDOOR

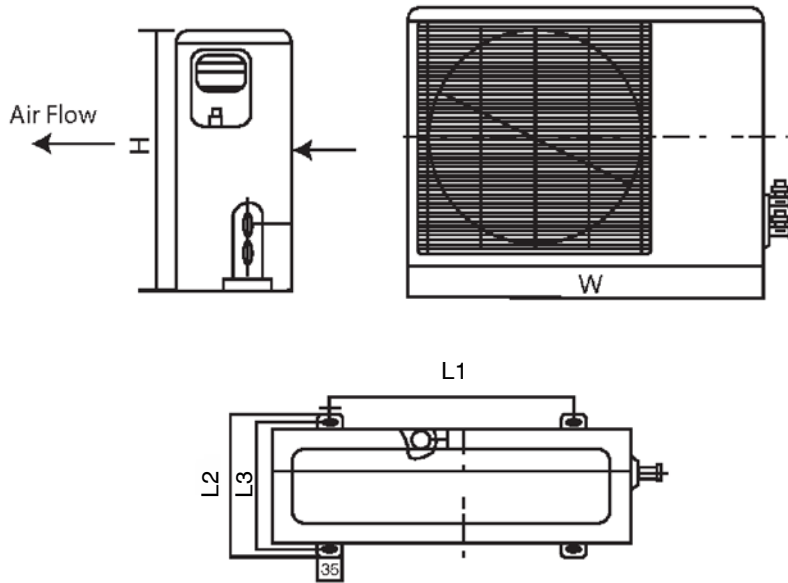

Model Size	W in. (mm)	H in. (mm)	L1 in. (mm)	L2 in. (mm)	L3 in. (mm)	Operating Weight lb (kg) Cooling Only	Operating Weight lb (kg) Heat Pumps
09	30 (762)	21.3 (541)	21.3 (541)	12.6 (320)	11.3 (287)	96 (44)	96 (44)
12	30 (762)	23.2 (589)	21.3 (541)	12.6 (320)	11.3 (287)	99 (45)	99 (45)
18	35 (889)	27.6 (701)	22 (559)	15.6 (396)	14.5 (368)	107 (49)	107 (49)
24	36 (914)	31.1 (790)	24 (610)	16.8 (427)	15.7 (399)	121 (55)	121 (55)
30	36 (914)	31.1 (790)	24 (610)	16.8 (427)	15.7 (399)	154 (70)	154 (70)
36	36 (914)	31.1 (790)	24 (610)	16.8 (427)	15.7 (399)	161 (73)	161 (73)

<b>Physical Data - Air Conditioner</b>						
<b>OUTDOOR/INDOOR MODEL SIZE</b>	<b>09J1A</b>	<b>12J1A</b>	<b>12K1A</b>	<b>18K1A</b>	<b>24K1A</b>	<b>36K1A</b>
Cooling Capacity	9000	12000	12000	18000	21400	33600
SEER	22	20	20	18	18	16
Operating Range °F (°C)	55 - 115 (13 - 46)	55 - 115 (13 - 46)	5 - 109 (-15 - 43)	5 - 109 (-15 - 43)	5 - 109 (-15 - 43)	64 - 109 (18 - 43)
Moisture removal Pints/hr (Liters/hr)	1.69 (0.8)	2.96 (1.4)	2.96 (1.4)	3.8 (1.8)	5.28 (2.5)	7.4 (3.5)
Indoor Fan CFM (L/M/H/HH)	218/253/294/330	218/253/278/300	218/253/278/300	324/383/459/500	353/412/471/589	677/706/824
Indoor Sound Pressure dBa	26/30/34/38	26/32/36/40	33/36/39/44	35/40/44/49	37/41/45/51	53/56/58
Outdoor Sound Pressure dBa	53	55	62	55	56	65
Mixed Phase Line Connection Size (in)	1/4	1/4	1/4	1/4	1/4	1/4
Vapor Line Connection Size (in)	3/8	3/8	3/8	1/2	5/8	5/8
Maximum vertical Separation ft (m)	33 (10)	33 (10)	33 (10)	33 (10)	33 (10)	33 (10)
Maximum Line Length ft (m)	50 (15)	66 (20)	66 (20)	82 (25)	82 (25)	98 (30)
Factory Charge R-410A lbs. (kg)	2.65 (1.2)	2.86 (1.3)	2.86 (1.3)	3.09 (1.4)	3.53 (1.6)	5.3 (2.4)
Additional charge (over 25 ft) oz./ft (g/m)	0.16 (15)	0.16 (15)	0.16 (15)	0.16 (15)	0.16 (15)	0.54 (50)
<b>Outdoor Electrical Data - Air Conditioner</b>						
Supply Voltage	115-1-60 AC			208/230-1-60 AC		
Minimum Circuit Ampacity MCA	22	23	10	13	16	24
Maximum Over current Protective Device MOCP	35	40	15	20	25	35
Compressor RLA/LRA	16.03/33	17.53/33	6.47/13.8	9.7/13.8	11.04/18.5	16.92/67
Fan Motor Amps	0.17	0.17	0.14	0.32	1.10	0.73
<b>Indoor Electrical Data - Air Conditioner</b>						
Required Supply Voltage	115-1-60 AC			208/230-1-60 AC		
FLA	0.38	0.38	0.20	0.28	0.24	0.47

Physical Data - Heat Pumps							
OUTDOOR/INDOOR MODEL SIZE	09J1A	12J1A	12K1A	18K1A	24K1A	30K1A	36K1A
Cooling Capacity	9000	12000	12000	18000	21400	28000	33600
SEER	22	20	20	18	18	16	16
Heating Capacity	9500	12100	13000	19800	23000	30600	34600
SEER	9.8	9.6	9.2	10	10	8.2	7.8
Cooling Ambient Operating Range °F (°C)	55 - 115 (13 - 46)	55 - 115 (13 - 46)	5 - 109 (-15 - 43)	5 - 109 (-15 - 43)	5 - 109 (-15 - 43)	5 - 109 (-15 - 43)	64 - 109 (18 - 43)
Heating Ambient Operating Range °F (°C)	5 - 75 (-15 - 24)	5 - 75 (-15 - 24)	5 - 75 (-15 - 24)	19.4 - 75 (-7 - 24)	19.4 - 75 (-7 - 24)	19.4 - 75 (-7 - 24)	19.4 - 75 (-7 - 24)
Moisture removal Pints/hr (Liters/hr)	1.69 (0.8)	2.96 (1.4)	2.96 (1.4)	3.8 (1.8)	5.28 (2.5)	7.4 (3.5)	7.4 (3.5)
Indoor Fan CFM (L/M/H/HH)	218/253/ 294/330	218/253/ 278/300	218/253/ 278/300	324/383/ 459/500	353/412/ 471/589	677/706/ 824	677/706/ 824
Indoor Sound Pressure dBa	26/30/34/38	26/32/36/40	33/36/39/44	35/40/44/49	37/41/45/51	53/56/58	53/56/58
Outdoor Sound Pressure dBa	53	55	62	55	56	65	65
Mixed Phase Line Connection Size (in)	1/4	1/4	1/4	1/4	1/4	1/4	1/4
Vapor Line Connection Size (in)	3/8	3/8	3/8	1/2	5/8	5/8	5/8
Maximum vertical Separation ft (m)	33 (10)	33 (10)	33 (10)	33 (10)	33 (10)	33 (10)	33 (10)
Maximum Line Length ft (m)	50 (15)	66 (20)	66 (20)	82 (25)	82 (25)	98 (30)	98 (30)
Factory Charge R-410A lbs. (kg)	2.65 (1.2)	2.86 (1.3)	2.86 (1.3)	3.09 (1.4)	3.53 (1.6)	5.3 (2.4)	5.73 (2.6)
Additional charge (over 25 ft) oz./ft (g/m)	0.22 (20)	0.22 (20)	0.22 (20)	0.22 (20)	0.54 (50)	0.54 (50)	0.54 (50)
Outdoor Electrical Data - Heat Pumps							
Supply Voltage	115-1-60 AC			208/230-1-60 AC			
Minimum Circuit Ampacity - MCA (amps)	22	23	10	13	16	20	24
Maximum Over Current Protective Device - MOCP (amps)	35	40	15	20	25	30	40
Compressor RLA/LRA	16.03/33	17.53/33	6.47/13.8	9.7/13.8	11.04/18.5	13.45/40	17.5/67
Fan Motor Amps	0.17	0.17	0.14	0.32	1.10	0.45	0.73
Indoor Electrical Data - Heat Pumps							
Required supply Voltage	115-1-60 AC			208/230-1-60 AC			
FLA	0.38	0.38	0.20	0.28	0.24	0.40	0.47

ACCESSORIES			
Part Number	Description	Used On Voltage	Used On Model Size
NADA001DK	Condensate Pump	115V	9, 12
NADA002DK	Condensate Pump	208/230V	12, 18, 24
NADA003DK	Condensate Pump	208/230V	30, 36

MODEL NOMENCLATURE											
MODEL SERIES	D	L	C	4	A	V	0	9	J	1	A
Position Number	1	2	3	4	5	6	7	8	9	10	11
DLC = Outdoor DLF = Indoor			Outdoor/Indoor								
4AV = AC Outdoor 4AH = AC Indoor 4HV = HP Outdoor 4HH = HP Indoor						Type					
09 = 9k BTU 12 = 12k BTU 18 = 18k BTU 24 = 24k BTU 30 = 30k BTU 36 = 36k BTU						Size					
J = 115-1-60 K = 208/230-1-60						Voltage					
1A						Factory Designation					