



Advanced Heating  
& Hot Water Systems

High Efficiency

# UFT BOILER

## Medium Mass

316L Stainless Steel, Fire  
Tube Heat Exchanger

10 to 1 Turndown Ratio

Advanced Modulating Gas  
Condensing Boiler; up to  
96% AFUE

Venting: 2" or 3" PVC, CPVC  
or Polypropylene

No Primary / Secondary  
Piping Needed

Supply and Return Connections  
on Both the Top and Bottom



[www.htproducts.com](http://www.htproducts.com)



**FIGHTING THE HIGH COST OF HEATING**

# UFT Boiler

A CLOSER LOOK

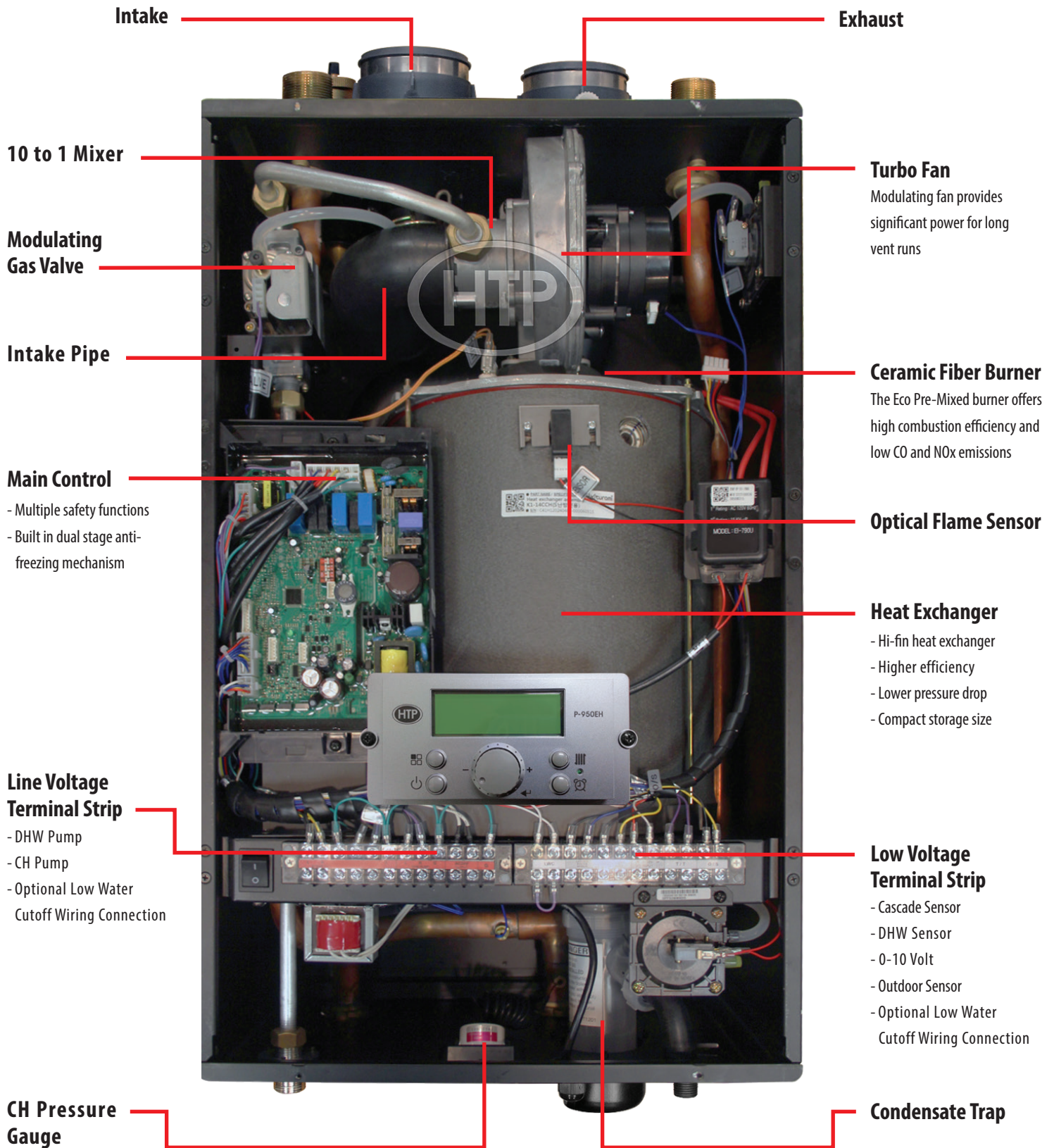

**Intake**

**Exhaust**

**10 to 1 Mixer**

**Modulating Gas Valve**

**Intake Pipe**

**Main Control**

- Multiple safety functions
- Built in dual stage anti-freezing mechanism

**Line Voltage Terminal Strip**

- DHW Pump
- CH Pump
- Optional Low Water Cutoff Wiring Connection

**CH Pressure Gauge**

**Turbo Fan**

Modulating fan provides significant power for long vent runs

**Ceramic Fiber Burner**

The Eco Pre-Mixed burner offers high combustion efficiency and low CO and NOx emissions

**Optical Flame Sensor**

**Heat Exchanger**

- Hi-fin heat exchanger
- Higher efficiency
- Lower pressure drop
- Compact storage size

**Low Voltage Terminal Strip**

- Cascade Sensor
- DHW Sensor
- 0-10 Volt
- Outdoor Sensor
- Optional Low Water Cutoff Wiring Connection

**Condensate Trap**

# MULTIFUNCTION CONTROL PANEL

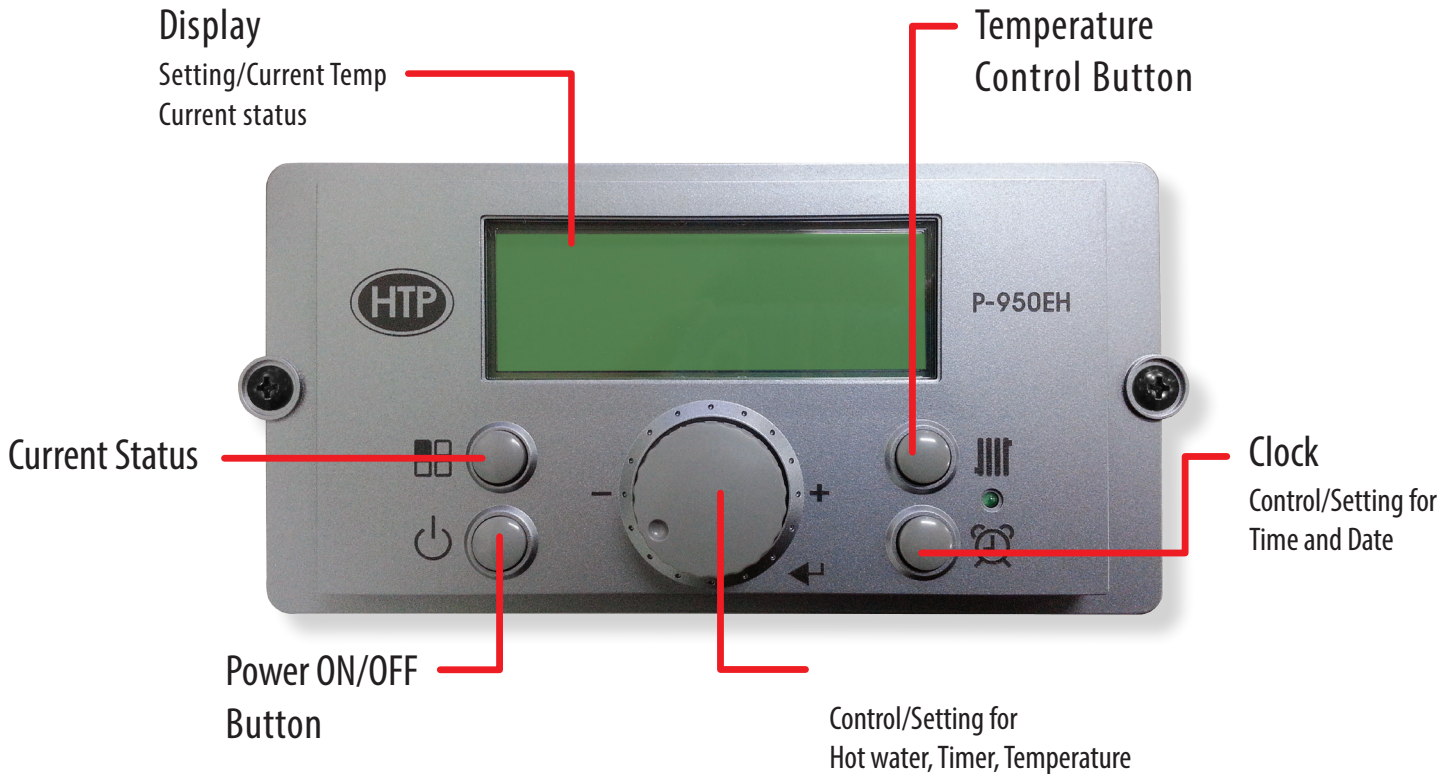

## INCLUDED IN THE BOX

- 2 Vent Screens (3")
- 30 PSI Pressure Relief Valve
- 1 1/4" x 1 1/4" x 3/4" Tee (steel)  
& 3/4" Street Elbow (steel)
- Anchors & Wall Mounting  
Bracket
- Quick Reference Guide,  
User & Installation Manuals
- Condensate Hose
- Spare Parts Kit
- 3" CPVC Pipe (6" Length)
- Outdoor Sensor with  
Screws & Anchors

## OPTIONAL EQUIPMENT

- System Sensor
- Indirect Tank Sensor
- 3", 4", 6" Stainless Steel  
Outside Termination Vent Kit
- 3" PVC Concentric Vent Kit
- U.L. 353 Compliant Low  
Water Cutoff w/ Manual Reset
- PC Connection Kit
- Condensate Neutralizer

Model	UFT-80W	UFT-100W	UFT-120W	UFT-140W	UFT-175W	UFT-199W
AFUE	95.4%	95.1%	95.6%	95.0%	95.9%	96.0%



# DIMENSIONS

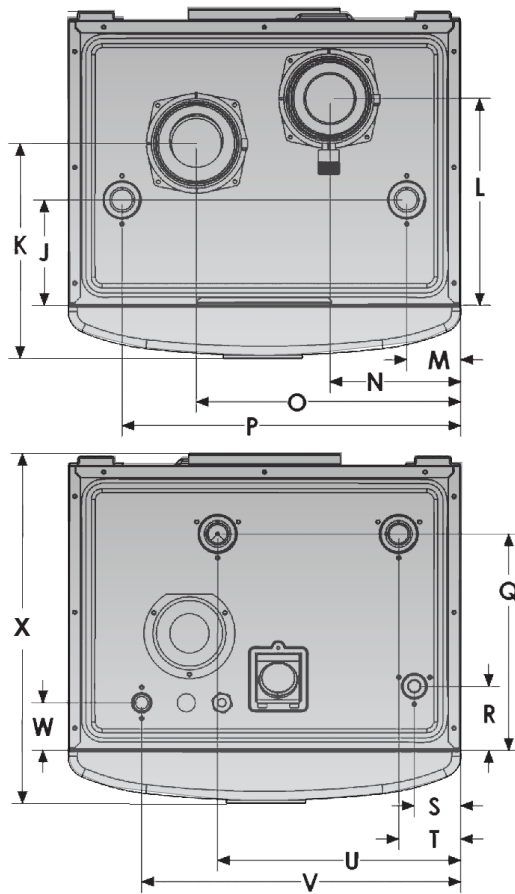
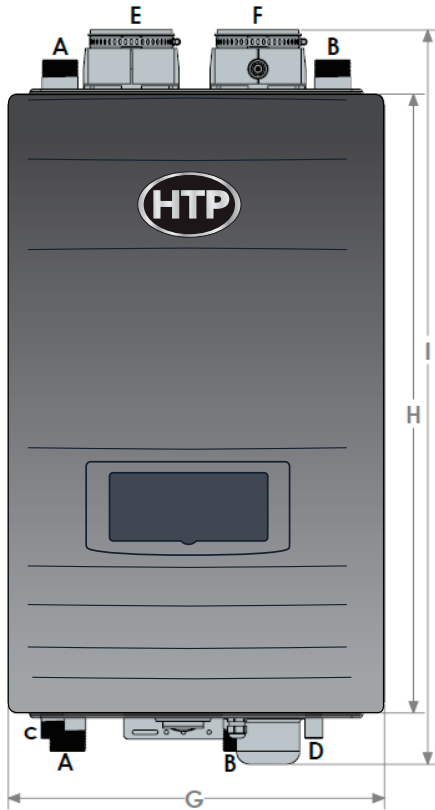

	DESCRIPTION	DIAMETER
A	CH SUPPLY ADAPTERS	1-1/4" NPT
B	CH RETURN ADAPTERS	1-1/4" NPT
C	GAS CONNECTION ADAPTER	3/4" NPT
D	CONDENSATE DRAIN ADAPTER	1/2" NPT
E	AIR INTAKE PIPE CONNECTION	3"
F	EXHAUST PIPE CONNECTION	3"

MODEL	G	H	I	J	K	L	M	N	O	P	Q	R	S	T	U	V	W	X
UFT-80W UFT-100W	17.5	28.75	34	47	73	9.1	2.4	5.8	11.7	14.9	9.6	2.8	2.1	2.7	10.7	14.1	2.1	15.4
UFT-120W UFT-140W	17.5	28.75	34	47	73	9.1	2.4	5.8	11.7	14.9	9.6	2.8	2.1	2.7	10.7	14.1	2.1	15.4
UFT-175W UFT-199W	19.7	31.9	37	67	88	10.8	2.75	5.8	12.5	17.5	9.9	2.8	2.1	2.2	11.7	15.8	2.2	16.8

Model	UFT-80W	UFT-100W	UFT-120W	UFT-140W	UFT-175W	UFT-199W
Input Rate	8,000~80,000 Btu/hr	10,000~100,000 Btu/hr	12,000~120,000 Btu/hr	14,000~140,000 Btu/hr	19,900~175,000 Btu/hr	19,900~199,000 Btu/hr
AFUE	95.4%	95.1%	95.6%	95.0%	95.9%	96.0%
Dimensions (W - H - D)	W 17.25" - H 29.0" - D 15.5"				W 19.68" - H 31.89" - D 17"	
Installation Type	Indoor / Wall hung					
Vent Type	Forced Draft Direct-vent					
Combined Vent Length & Venting Materials	2"(50ft) , 3"(100ft) / PVC, CPVC, PP & Power Vent					
Ignition	Direct Electronic Ignition					
Gas Supply Pressure	Natural Gas		3.5" WC to 14" WC			
	Propane Gas		3.5" WC to 14" WC			
Power Supply	Main Supply		120V 60Hz			
	Max Power		160W			
Water Pressure	Min 12 ~ Max 30 PSI					
Connection Sizes	Supply/Return		1-1/4" NPT			
	Gas Inlet		3/4" NPT			
Warranty	Limited 10 Year Residential Warranty					

In accordance with our company policy of ongoing product improvement, HTP Inc. reserves the right to make changes without prior notice.

MKTLIT-81 - 04 / 2016 © HTP

72 Duchaine Blvd, New Bedford, MA 02745 • 1-800-323-9651 • [www.htproducts.com](http://www.htproducts.com)