

10GCS/10CHA/10CHP MERIT SERIES UNITS

The **10GCS** heat/cool package series units, are available in sizes ranging from 2 through 5 tons (7.0 through 17.6 kW). The GCS series units were designed for outdoor residential use only. Units can be installed at ground level, or roof top applications. Gas heat sections are available with Lennox tested S-curve heat exchangers in 50,000, 75,000, 100,000, 125,000 and 150,000 Btuh input sizes.

The unit utilizes a single heavy duty, high efficient, reciprocating compressor except for the 10GCS-048 and 10GCS-060 which utilizes a scroll compressor. The compressor has overload protection and it's own cover, for reducing operating sound levels.

The **10CHA** series units are available in sizes ranging from 2 through 5 tons (7.0 through 17.6 kW). The CHA 29 series units were designed for outdoor residential use only. Units can be installed at ground level or rooftop applications. Optional field installed electric heat is available in 5, 7, 10, 15, 20 and 25 kW. All electric heat operates in single stage.

The unit utilizes a single heavy duty, high efficient, reciprocating compressor except for the 10CHA-048 and 10CHA-060 which utilizes a scroll compressor. The compressor has overload protection and it's own cover, for reducing operating sound levels.

The **10CHP** package heat pump series units are available in sizes ranging from 2 through 5 tons (7.0 through 17.6 kW). The 10CHP series units were designed for outdoor residential use only. Units can be installed at ground level or rooftop applications. The unit utilizes a reversing valve, defrost control and other parts common to a heat pump. Optional field installed supplemental electric heat is available in 5, 7, 10, 15, 20 and 25 kW. All electric heat operates in single stage.

The unit utilizes a single heavy duty, high efficient, reciprocating compressor except for the 10CHP-048 and 10CHP-060 which utilizes a scroll compressor. The compressor has overload protection

Information contained in this manual is intended for use by qualified service technicians only. All specifications are subject to change. Procedures outlined in this manual are presented as a recommendation only and do not supersede or replace local or state codes.



10GCS



10CHA



10CHP

TABLE of CONTENTS

Introduction.....1	VI Charging25,26
Specifications/Blower Data 10GCS.....3,6	Charging 10CHP25
High Altitude 10GCS.....6	Charging 10GCS, 10CHA26
Specifications/Blower Data 10CHA.....7,8	VII Maintenance27
Specifications/Blower Data 10CHP.....9,10	VIII Wiring Diagram and Sequence of Operation
Parts Arrangement.....11,13	10GCS28
I Application14	10CHP29
II Unit Components14,18	10CHA30
Control Box14,18	Optional Electric Heat31
Gas17,18	
III Main Blower18	
IV Electric Heat19,23	
V Cooling Components24	

**ELECTROSTATIC DISCHARGE (ESD)
Precautions and Procedures**

⚠ CAUTION

Electrostatic discharge can affect electronic components. Take precautions during unit installation and service to protect the unit's electronic controls. Precautions will help to avoid control exposure to electrostatic discharge by putting the unit, the control and the technician at the same electrostatic potential. Neutralize electrostatic charge by touching hand and all tools on an unpainted unit surface before performing any service procedure.

**ELECTROSTATIC DISCHARGE (ESD)
Precautions and Procedures**

⚠ CAUTION

Electrostatic discharge can affect electronic components. Take precautions during furnace installation and service to protect the furnace's electronic controls. Precautions will help to avoid control exposure to electrostatic discharge by putting the furnace, the control and the technician at the same electrostatic potential. Neutralize electrostatic charge by touching hand and all tools on an unpainted unit surface, such as the gas valve or blower deck, before performing any service procedure.

SPECIFICATIONS - 10GCS

Model No.		10GCS024-50 10GCS024X-50	10GCS024-75 10GCS024X-75	10GCS030-50 10GCS030X-50	10GCS030-75 10GCS030X-75	10GCS036-50 10GCS036X-50	10GCS036-75 10GCS036X-75
Heating capacity input- Btuh (kW)		50,000 (14.7)	75,000 (22.0)	50,000 (14.7)	75,000 (22.0)	50,000 (14.7)	75,000 (22.0)
Heating capacity output- Btuh (kW)		40,000 (11.7)	60,000 (17.6)	40,000 (11.7)	60,000 (17.6)	40,000 (11.7)	60,000 (17.6)
① A.F.U.E.		80.0%					
Temperature Rise - °F (°C)		30-60 (17-33)	45-75 (25-42)				
Gas Supply Connections fpt - in. (mm)		1/2 (13)					
Recommended Gas Supply Pressure - in. w.g. (Pa)		7 (1.7) Natural Gas, 11 (2.7) LPG/Propane					
② ARI Standard 210/240 Ratings	Total cooling capacity - Btuh (kW)	23,400 (6.9)		29,000 (8.5)		35,000 (10.3)	
	Total unit watts	2540		3150		3850	
	SEER (Btuh/Watt)	10.00					
	EER (Btuh/Watt)	9.2				9.1	
Sound Rating Number (db)		76				80	
Refrigerant Charge (HCFC-22)		3 lbs. 4 oz. (1.47 kg)		3 lbs. 3 oz. (1.45 kg)		3 lbs. 10 oz. (1.64 kg)	
Evaporator Blower	Blower wheel size dia. x width in. (mm)	10 x 8 (254 x 203)					
	Motor horsepower (W)	1/2 (373)					
Evaporator Coil	Net face area - sq. ft. (m ²)	3.6 (0.33)					
	Tube diameter - in. (mm) & No. of rows	3/8 (9.5) - 2				3/8 (9.5) - 3	
	Fins per inch (m)	14 (551)					
Condenser Coil	Net face area - sq. ft. (m ²)	9.3 (0.86)		10.3 (0.96)			
	Tube dia. - in. (mm) & No. of rows	5/16 (8) - 1		3/8 (9.5) - 1			
	Fins per inch (m)	18 (709)					
Condenser Coil Fan	Diameter - in. (mm) & No. of blades	18 (457) - 3		18 (457) - 4			
	Air Volume - cfm (L/s)	2100 (990)				2300 (1085)	
	Motor horsepower (W)	1/8 (93)				1/4 (187)	
	Motor watts	170				250	
Condensate drain size fpt - in. (mm)		(1) 3/4 (19)					
③ No. & size of filters - in. (mm)		(1) 24 x 25 x 1 (610 x 635 x 25)					
Net weight of basic unit - lbs. (kg)		280 (127)	290 (132)	295 (134)	300 (136)	350 (159)	320 (145)
Shipping weight of basic unit - lbs. (kg) (1 Package)		295 (134)	305 (138)	310 (141)	315 (143)	365 (166)	335 (152)
Electrical characteristics (60 hz)		208/230v - 1 ph - 60 hz					
OPTIONAL ACCESSORIES - MUST BE ORDERED EXTRA							
LPG/Propane Kit		42K91					
Low Ambient Control Kit		42K88					
Timed-Off Control		42K90					
High Pressure Switch		42K89					

① Annual Fuel Utilization Efficiency based on U.S. DOE test procedures and FTC labeling regulations.

② Rated in accordance with ARI Standard 210/240; 95°F (35°C) outdoor air temperature, 80°F (27°C) db / 67°F (19°C) wb entering evaporator air.

③ Filters are not furnished and must be field provided.

SPECIFICATIONS - 10GCS

Model No.		10GCS036-100 10GCSX036-100	10GCS042-75 10GCSX042-75	10GCS042-100 10GCSX042-100	10GCS048-100 10GCSX048-100	10GCS048-125 10GCSX048-125
Heating capacity input- Btuh (kW)		100,000 (29.3)	75,000 (22.0)	100,000 (29.3)	100,000 (29.3)	125,000 (36.6)
Heating capacity output- Btuh (kW)		80,000 (23.4)	60,000 (17.6)	80,000 (23.4)	80,000 (23.4)	100,000 (29.3)
①A.F.U.E.		80.0%				
Temperature Rise - °F (°C)		55-85 (31-47)	45-75 (14-30)	55-85 (31-47)	40-70 (22-39)	45-75 (14-30)
Gas Supply Connections fpt - in. (mm)		1/2 (13)				
Recommended Gas Supply Pressure - in. w.g. (Pa)		7 (1.7) Natural Gas, 11 (2.7) LPG/Propane				
②ARI Standard 210/240 Ratings	Total cooling capacity - Btuh (kW)	35,000 (10.3)	41,000 (12.0)		47,000 (13.8)	
	Total unit watts	3850	4460		5050	
	SEER (Btuh/Watt)	10.00				
	EER (Btuh/Watt)	9.1	9.2		9.3	
Sound Rating Number (db)		80				
Refrigerant Charge (HCFC-22)		3 lbs. 10 oz. (1.64 kg)	4 lbs. 9 oz. (2.07 kg)		5 lbs. 13 oz. (2.64 kg)	
Evaporator Blower	Blower wheel size dia. x width in. (mm)	10 x 8 (254 x 203)	10 x 9 (254 x 229)		12 x 10 (305 x 254)	
	Motor horsepower (W)	1/2 (373)			1 (746)	
Evaporator Coil	Net face area - sq. ft. (m ²)	3.6 (0.33)	4.2 (0.39)		6.1 (0.57)	
	Tube diameter - in. (mm) & No. of rows	3/8 (9.5) - 3				
	Fins per inch (m)	14 (551)			15 (591)	
Condenser Coil	Net face area - sq. ft. (m ²)	10.3 (0.96)			15.4 (1.43)	
	Tube diameter - in. (mm) & No. of rows	3/8 (9.5) - 1				
	Fins per inch (m)	18 (709)				
Condenser Coil Fan	Diameter - in. (mm) & No. of blades	18 (457) - 4			20 (508) - 4	
	Air Volume - cfm (L/s)	2300 (1085)			3000 (1415)	
	Motor horsepower (W)	1/4 (187)				
	Motor watts	250			325	
Condensate drain size fpt - in. (mm)		(1) 3/4 (19)				
③No. & size of filters - in. (mm)		(1) 24 x 25 x 1 (610 x 635 x 25)	(1) 28 x 25 x 1 (711 x 635 x 25)		(1) 30 x 30 x 1 (762 x 762 x 25)	
Net weight of basic unit - lbs. (kg)		330 (150)	350 (158)	360 (163)	410 (186)	430 (195)
Shipping weight of basic unit - lbs. (kg) (1 Package)		345 (156)	365 (166)	375 (170)	425 (193)	445 (202)
Electrical characteristics		208/230v-1ph-60hz				
OPTIONAL ACCESSORIES - MUST BE ORDERED EXTRA						
LPG/Propane Kit		42K91				
Low Ambient Control Kit		42K88				
Timed-Off Control		42K90				
High Pressure Switch		42K89				

①Annual Fuel Utilization Efficiency based on U.S. DOE test procedures and FTC labeling regulations.

②Rated in accordance with ARI Standard 210/240; 95°F (35°C) outdoor air temperature, 80°F (27°C) db / 67°F (19°C) wb entering evaporator air.

③Filters are not furnished and must be field provided.

SPECIFICATIONS - 10GCS

Model No.		10GCS048-150 10GCSX048-150	10GCS060-100 10GCSX060-100	10GCS060-125 10GCSX060-125	10GCS060-150 10GCSX060-150
Heating capacity input- Btuh (kW)		150,000 (44.0)	100,000 (29.3)	125,000 (36.6)	150,000 (44.0)
Heating capacity output- Btuh (kW)		120,000 (35.2)	80,000 (23.4)	100,000 (29.3)	120,000 (35.2)
①A.F.U.E.		80.0%			
Temperature Rise - °F (°C)		60-90 (33-50)	40-70 (22-39)	45-75 (14-30)	60-90 (33-50)
Gas Supply Connections fpt - in. (mm)		1/2 (13)			
Recommended Gas Supply Pressure - in. w.g. (Pa)		7 (1.7) Natural Gas, 11 (2.7) LPG/Propane			
②ARI Standard 210/240 Ratings	Total cooling capacity - Btuh (kW)	47,000 (13.8)	58,000 (17.0)		
	Total unit watts	5050	6445		
	SEER (Btuh/Watt)	10.00			
	EER (Btuh/Watt)	9.3	9.0		
Sound Rating Number (db)		80			
Refrigerant Charge (HCFC-22)		5 lbs. 13 oz. (2.64 kg)	6 lbs. 14 oz. (3.12 kg)		
Evaporator Blower	Blower wheel size dia. x width in. (mm)	12 x 10 (305 x 254)			
	Motor horsepower (W)	1 (746)	.9 (671)		
Evaporator Coil	Net face area - sq. ft. (m ²)	6.1 (0.57)			
	Tube diameter - in. (mm) & No. of rows	3/8 (9.5) - 3			
	Fins per inch (m)	15 (591)			
Condenser Coil	Net face area - sq. ft. (m ²)	15.4 (1.43)	17.5 (1.63)		
	Tube diameter - in. (mm) & No. of rows	3/8 (9.5) - 1			
	Fins per inch (m)	18 (709)			
Condenser Coil Fan	Diameter - in. (mm) & No. of blades	20 (508) - 4			
	Air Volume - cfm (L/s)	3000 (1415)			
	Motor horsepower (W)	1/4 (187)			
	Motor watts	325			
Condensate drain size fpt - in. (mm)		(1) 3/4 (19)			
③No. & size of filters - in. (mm)		(1) 30 x 30 x 1 (762 x 762 x 25)			
Net weight of basic unit - lbs. (kg)		440 (200)	450 (204)	460 (209)	470 (213)
Shipping weight of basic unit - lbs. (kg) (1 Package)		455 (206)	465 (211)	475 (215)	485 (220)
Electrical characteristics		208/230v-1ph-60hz			
OPTIONAL ACCESSORIES - MUST BE ORDERED EXTRA					
LPG/Propane Kit		42K91			
Low Ambient Control Kit		42K88			
Timed-Off Control		42K90			
High Pressure Switch		42K89			

①Annual Fuel Utilization Efficiency based on U.S. DOE test procedures and FTC labeling regulations.

②Rated in accordance with ARI Standard 210/240; 95°F (35°C) outdoor air temperature, 80°F (27°C) db / 67°F (19°C) wb entering evaporator air.

③Filters are not furnished and must be field provided.

ELECTRICAL DATA - 10GCS

Model No.		10GCS024	10GCS030	10GCS036	10GCS042	10GCS048	10GCS060
Line voltage data - 60hz 1 phase		208/230v					
① Recommended maximum fuse size or circuit breaker size (amps)		25	30		35	40	45
② Minimum Circuit Ampacity		16.6	20.8	24.9	26.7	34.1	38.1
Compressor	Rated load amps	10.5	13.7	16.4	17.2	21.8	25.0
	Locked rotor amps	56	76.1	96	105	116	170
Condenser Coil Fan Motor	Full load amps	0.9			1.8		
	Locked rotor amps	1.7			3.8		
Evaporator Coil Blower Motor	Full load amps	2.6			3.4	5.0	
	Locked rotor amps	5.5			8.3	10.9	
Unit power factor		.98	.99	.95		.98	

① Where current does not exceed 100 amps, HACR type circuit breaker may be used in place of fuse (U.S. only).

② Refer to National or Canadian Electrical Code manual to determine wire, fuse and disconnect size requirements.

NOTE - Extremes of operating range are plus and minus 10% of line voltage.

BLOWER DATA-10GCS

10GCS024 BLOWER PERFORMANCE							
① Horizontal Air Flow							
External Static Pressure		Air Volume at Various Blower Speeds					
		High		Medium		Low	
in. w.g.	Pa	cfm	L/s	cfm	L/s	cfm	L/s
.20	50	1350	635	1140	540	1050	495
.30	75	1280	605	1090	515	1010	475
.40	100	1220	575	1050	495	970	455
.50	125	1140	540	980	460	900	425
.60	150	1060	500	920	435	850	400
.70	175	960	455	820	385	760	360
.80	200	850	400	750	355	700	330

① For down-flow air volume, add 0.10 in. w.g. (25 Pa) to duct static.
NOTE — All air data is measured external to unit without air filters.

10GCS042 BLOWER PERFORMANCE							
① Horizontal Air Flow							
External Static Pressure		Air Volume at Various Blower Speeds					
		High		Medium		Low	
in. w.g.	Pa	cfm	L/s	cfm	L/s	cfm	L/s
.20	50	1590	750	1520	715	1470	695
.30	75	1540	725	1470	695	1420	670
.40	100	1460	690	1430	675	1350	635
.50	125	1380	650	1340	630	1270	600
.60	150	1300	615	1250	590	1200	565
.70	175	1220	575	1190	560	1130	535
.80	200	1130	535	1100	520	1050	495

① For down-flow air volume, add 0.10 in. w.g. (25 Pa) to duct static.
NOTE — All air data is measured external to unit without air filters.

10GCS030 AND 10GCS036 BLOWER PERFORMANCE							
① Horizontal Air Flow							
External Static Pressure		Air Volume at Various Blower Speeds					
		High		Medium		Low	
in. w.g.	Pa	cfm	L/s	cfm	L/s	cfm	L/s
.20	50	1420	670	1170	550	1060	500
.30	75	1360	640	1140	540	1040	490
.40	100	1300	615	1100	520	1020	480
.50	125	1220	515	1050	495	970	460
.60	150	1140	535	990	465	920	435
.70	175	1050	495	910	430	850	400
.80	200	940	445	800	380	770	360

① For down-flow air volume, add 0.10 in. w.g. (25 Pa) to duct static.
NOTE — All air data is measured external to unit without air filters.

10GCS048 AND 10GCS060 BLOWER PERFORMANCE							
① Horizontal Air Flow							
External Static Pressure		Air Volume at Various Blower Speeds					
		High		Medium		Low	
in. w.g.	Pa	cfm	L/s	cfm	L/s	cfm	L/s
.20	50	2360	1115	2140	1010	1820	860
.30	75	2290	1080	2090	985	1800	850
.40	100	2190	1035	2020	955	1780	840
.50	125	2110	995	1920	905	1750	825
.60	150	2010	950	1850	875	1680	795
.70	175	1920	905	1780	840	1610	760
.80	200	1820	860	1710	805	1470	695

① For down-flow air volume, add 0.10 in. w.g. (25 Pa) to duct static.
NOTE — All air data is measured external to unit without air filters.

HIGH ALTITUDE DERATE-10GCS

Units may be installed at altitudes up to 4500 feet (1372 m) above sea level without any modification. At altitudes above 4500 feet (1372 m), units must be derated 4% for every 1000 feet (470 m) above 4500 feet (1372 m). (Example - At an altitude of 6500 feet (1981 m) the unit would require a derate of 8%.)

NOTE — This is the only permissible derate for these units.

SPECIFICATIONS-10CHA

Model No.		10CHA024	10CHA030	10CHA036	10CHA042	10CHA048	10CHA060
ARI Standard 210/240 Ratings	Total cooling capacity - Btuh (kW)	23,400 (6.9)	29,000 (8.5)	35,000 (10.3)	41,000 (12.0)	47,000 (13.8)	58,000 (17.0)
	Total unit watts	2540	3150	3850	4460	5050	6445
	SEER (Btuh/Watt)	10.00					
	EER (Btuh/Watt)	9.2	9.2	9.1	9.2	9.3	9.0
Sound Rating Number (db)		76			80		
Refrigerant Charge (HCFC-22)		3 lbs 4 oz. (1.47 kg)	3 lbs. 3 oz. (1.45 kg)	3 lbs. 10 oz. (1.64 kg)	4 lbs. 9 oz. (2.07 kg)	5 lbs. 13 oz. (2.64 kg)	6 lbs. 14 oz. (3.12 kg)
Evaporator Blower	Blower wheel size dia. x width in. (mm)	10 x 6 (152 x 203)	10 x 8 (254 x 203)		10 x 9 (254 x 229)	12 x 10 (305 x 254)	
	Motor horsepower (W)	1/2 (373)			1 (746)		
Evaporator Coil	Net face area - sq. ft. (m ²)	3.6 (0.33)			4.2 (0.39)	6.1 (0.57)	
	Tube diameter - in. (mm) & No. of rows	3/8 (9.5) - 2		3/8 (9.5) - 3			
	Fins per inch (m)	14 (551)				15 (591)	
Condenser Coil	Net face area - sq. ft. (m ²)	9.3 (0.86)	10.3 (0.96)		14.4 (1.34)	15.4 (1.43)	17.5 (1.63)
	Tube diameter - in. (mm) & No. of rows	5/16 (7.9) - 1	3/8 (9.5) - 1				
	Fins per inch (m)	18 (709)					
Condenser Coil Fan	Diameter - in. (mm) & No. of blades	18 (457) - 3		18 (457) - 4		20 (508) - 4	
	Air Volume - cfm (L/s)	2100 (990)		2300 (1085)		3000 (1415)	
	Motor horsepower (W)	1/8 (93)		1/4 (187)			
	Motor watts	170		250		325	
Condensate drain size fpt - in. (mm)		(1) 3/4 (19)					
No. & size of filters - in. (mm)		(1) 24 x 25 x 1 (610 x 635 x 25)			(1) 28 x 25 x 1 (711 x 635 x 25)		(1) 30 x 30 x 1 (762 x 762 x 25)
Net weight of basic unit - lbs. (kg)		260 (118)	280 (127)	300 (136)	330 (150)	420 (191)	440 (200)
Shipping weight of basic unit - lbs. (kg) (1 Package)		275 (125)	295 (134)	315 (143)	345 (157)	435 (197)	455 (206)
Electrical characteristics (60 hz)		208/230v-1ph					
OPTIONAL ACCESSORIES - MUST BE ORDERED EXTRA							
Electric Heat - kW range		05-07-10	05-07-10-15-20			10-15-20-25	
Low Ambient Control Kit		42K88					
Timed-Off Control		42K90					
Outdoor Thermostat Kit	Thermostat Kit	LB-29740BA (56A87)					
	Mounting Box	M-1595 (31461)					
High Pressure Switch		42A89					

① Rated in accordance with ARI Standard 210/240; 95°F (35°C) outdoor air temperature, 80°F (27°C) db / 67°F (19°C) wb entering evaporator air.

② Filters are not furnished and must be field provided.

ELECTRICAL DATA-10CHA

Model No.		10CHA024	10CHA030	10CHA036	10CHA042	10CHA048	10CHA060
Line voltage data - 60hz 1 phase		208/230v					
① Recommended maximum fuse size or circuit breaker size (amps)		25	30		35	40	45
② Minimum Circuit Ampacity		16.6	20.8	24.9	26.7	34.1	38.1
Compressor	Rated load amps	10.5	13.7	16.4	17.2	21.8	25.0
	Locked rotor amps	56	76.1	96	105	116	170
Condenser Coil Fan Motor	Full load amps	0.9		1.8			
	Locked rotor amps	1.7		3.8			
Evaporator Coil Blower Motor	Full load amps	2.6			3.4	5.0	
	Locked rotor amps	5.5			8.3	10.9	
Unit power factor		.98	.99	.95	.93	.98	

① Where current does not exceed 100 amps, HACR type circuit breaker may be used in place of fuse (U.S. only).

② Refer to National or Canadian Electrical Code manual to determine wire, fuse and disconnect size requirement

NOTE - Extremes of operating range are plus and minus 10% of line voltage.

BLOWER DATA-10CHA

10CHA024 BLOWER PERFORMANCE							
① Horizontal Air Flow							
External Static Pressure		Air Volume at Various Blower Speeds					
		High		Medium		Low	
in. w.g.	Pa	cfm	L/s	cfm	L/s	cfm	L/s
.20	50	1350	635	1140	540	1050	495
.30	75	1280	605	1090	515	1010	475
.40	100	1220	575	1050	495	970	460
.50	125	1140	540	980	460	900	425
.60	150	1060	500	920	435	850	400
.70	175	960	455	820	385	760	360
.80	200	850	400	750	355	700	330

① For down-flow air volume, add 0.10 in. w.g. (25 Pa) to duct static.

NOTE — All air data is measured external to unit without air filters.

10CHA042 BLOWER PERFORMANCE							
① Horizontal Air Flow							
External Static Pressure		Air Volume at Various Blower Speeds					
		High		Medium		Low	
in. w.g.	Pa	cfm	L/s	cfm	L/s	cfm	L/s
.20	50	1590	750	1520	715	1470	695
.30	75	1540	725	1470	695	1420	670
.40	100	1460	690	1430	675	1350	640
.50	125	1380	650	1340	630	1270	600
.60	150	1300	615	1250	590	1200	565
.70	175	1220	575	1190	560	1130	535
.80	200	1130	525	1100	520	1050	495

① For down-flow air volume, add 0.10 in. w.g. (25 Pa) to duct static.

NOTE — All air data is measured external to unit without air filters.

10CHA030 AND 10CHA036 BLOWER PERFORMANCE							
① Horizontal Air Flow							
External Static Pressure		Air Volume at Various Blower Speeds					
		High		Medium		Low	
in. w.g.	Pa	cfm	L/s	cfm	L/s	cfm	L/s
.20	50	1420	670	1170	550	1060	500
.30	75	1360	640	1140	540	1040	490
.40	100	1300	615	1100	520	1020	480
.50	125	1220	575	1050	495	970	460
.60	150	1140	540	990	470	920	435
.70	175	1050	495	910	430	850	400
.80	200	940	445	800	380	770	365

① For down-flow air volume, add 0.10 in. w.g. (25 Pa) to duct static.

NOTE — All air data is measured external to unit without air filters.

10CHA048 AND 10CHA060 BLOWER PERFORMANCE							
① Horizontal Air Flow							
External Static Pressure		Air Volume at Various Blower Speeds					
		High		Medium		Low	
in. w.g.	Pa	cfm	L/s	cfm	L/s	cfm	L/s
.20	50	2360	1115	2140	1010	1820	860
.30	75	2290	1080	2090	985	1800	850
.40	100	2190	1035	2020	955	1780	840
.50	125	2110	995	1920	905	1750	825
.60	150	2010	950	1850	875	1680	790
.70	175	1920	905	1780	840	1610	760
.80	200	1820	860	1710	805	1470	695

① For down-flow air volume, add 0.10 in. w.g. (25 Pa) to duct static.

NOTE — All air data is measured external to unit without air filters.

SPECIFICATIONS-10CHP

Model No.		10CHP024	10CHP030	10CHP036	10CHP042	10CHP048	10CHP060	
ARI Cooling Ratings	Cooling Capacity — Btuh (kW)	23,000 (6.7)	29,000 (8.5)	34,000 (10.0)	40,000 (11.7)	48,000 (14.1)	59,000 (17.3)	
	Total unit watts	2500	3185	3775	4445	5335	6555	
	SEER (Btuh/Watts)	10.0						
	EER (Btuh/Watts)	9.2	9.1	9.0				
ARI Certified High Temperature Heating Ratings	Total Capacity — Btuh (kW)	22,600 (6.6)	28,600 (8.4)	34,000 (10.0)	40,000 (11.7)	47,000 (13.8)	59,000 (17.3)	
	Total unit watts	2104	2700	3160	3660	4440	5760	
	C.O.P (Coefficient of Performance)	3.1		3.15	3.2	3.1	3.0	
	HSPF — Region IV	6.8		7.0	7.2	6.8		
ARI Certified Low Temperature Heating Ratings	Total Capacity — Btuh (kW)	12,600 (3.7)	15,800 (4.6)	21,000 (6.2)	22,600 (6.6)	27,600 (8.1)	36,000 (10.5)	
	Total unit watts	1850	2310	2800	3010	4040	5275	
	C.O.P (Coefficient of Performance)	2.0		2.2		2.0		
Sound Rating Number (db)		76			80			
Refrigerant Charge (HCFC-22)		5.0 lbs.0 oz. (2.3 kg)	4 lbs 11oz. (2.1 Oz.)	5 lbs. 9 oz. (2.5 kg)	6 lbs 6 oz. (2.9 kg)	7 lbs. 4 oz. (3.4 kg)	11 lbs 8 oz. (5.2 kg)	
Indoor Coil Blower	Blower wheel size D x W in. (mm)	10 x 6 (254 x 152)	10 x 8 (254 x 203)		10 x 9 (254 x 229)	12 x 10 (305 x 254)		
	Motor horsepower (W)	1/2 (373)				.9 (671)		
Indoor Coil	Net face area - sq. ft. (m ²)	3.6 (0.33)			4.2 (0.39)	6.1 (0.57)		
	Tube dia. - in. (mm) & No. of rows	5/16 (16.9) - 3			3/8 (9.5) - 3			
	Fins per inch (m)	14 (551)						
Outdoor Coil	Net face area - sq. ft. (m ²)	10.3 (0.96)	12.3 (1.14)		14.4 (1.34)	17.5 (1.63)		
	Tube dia. - in. (mm) & No. of rows	5/16 (16.9) - 1	3/8 (9.5) - 1				3/8 (9.5) - 2	
	Fins per inch (m)	16 (630)	20 (787)	15 (591)		16 (630)	15 (591)	
Outdoor Coil Fan	Diameter - in. (mm) & No. of blades	18 (457) - 4				20 (508) - 4		
	Air Volume - cfm (L/s)	2100 (990)		2300 (1085)		3000 (1415)		
	Motor horsepower (W)	1/8 (93)		1/4 (187)				
	Motor watts	170		250		325		
Condensate drain size fpt - in. (mm)		(1) 3/4 (19)						
No. & size of filters - in. (mm)		(1) 24 x 25 x 1 (610 x 635 x 25)			(1) 28 x 25 x 1 (711 x 635 x 25)	(1) 30 x 30 x 1 (762 x 762 x 25)		
Net weight of basic unit - lbs. (kg)		260 (118)	280 (127)	300 (136)	330 (149)	420 (195)	440 (200)	
Shipping weight of basic unit - lbs. (kg) (1 Package)		275 (125)	295 (134)	315 (143)	345 (156)	435 (197)	455 (206)	
Electrical characteristics		208/230v-1ph-60 hz						
OPTIONAL ACCESSORIES - MUST BE ORDERED EXTRA								
Supplemental Electric Heat - kW range		05-07-10	05-07-10-15-20			10-15-20-25		
Timed-Off Control		42K90						
Outdoor Thermostat Kit	Thermostat Kit	LB-29740BA (56A87)						
	Mounting Box	M-1595 (31461)						
High Pressure Switch		42K89						

ARI Rated in accordance with ARI Standard 210/240; 95°F (35°C) outdoor air temperature, 80°F (27°C) db / 67°F (19°C) wb entering evaporator air..

Filters are not furnished and must be ordered extra.

ELECTRICAL DATA-10CHP

Model No.	10CHP024	10CHP030	10CHP036	10CHP042	10CHP048	10CHP060	
Line voltage data - 60hz 1 phase	208/230v						
① Recommended maximum fuse size or circuit breaker size (amps)	25	30		35	45	55	
② Minimum Circuit Ampacity	15.8	20.6	21.7	26.6	34.0	41.6	
Compressor	Rated load amps	9.8	13.7	13.8	17.1	21.8	27.8
	Locked rotor amps	56	75	78.8	105	131	170
Outdoor Coil Fan Motor	Full load amps	0.9		1.8			
	Locked rotor amps	1.7		3.8			
Indoor Coil Blower Motor	Full load amps	2.6		3.4	5.0		
	Locked rotor amps	5.5		8.3	10.9		
Unit power factor	.97	.96	.98	.95	.98		

① Where current does not exceed 100 amps, HACR type circuit breaker may be used in place of fuse (U.S. only).

② Refer to National or Canadian Electrical Code manual to determine wire, fuse and disconnect size requirement

NOTE - Extremes of operating range are plus and minus 10% of line voltage.

BLOWER DATA-10CHP

10CHP024 BLOWER PERFORMANCE							
① Horizontal Air Flow							
External Static Pressure		Air Volume at Various Blower Speeds					
		High		Medium		Low	
in. w.g.	Pa	cfm	L/s	cfm	L/s	cfm	L/s
.20	50	1100	520	940	445	850	400
.30	75	1060	500	890	420	800	380
.40	100	1000	470	870	410	790	375
.50	125	940	445	840	395	770	365
.60	150	880	415	800	380	750	355
.70	175	800	380	720	385	670	315
.80	200	720	340	660	310	600	285

① For down-flow air volume, add 0.10 in. w.g. (25 Pa) to duct static.

NOTE — All air data is measured external to unit without air filters.

10CHP042 BLOWER PERFORMANCE							
① Horizontal Air Flow							
External Static Pressure		Air Volume at Various Blower Speeds					
		High		Medium		Low	
in. w.g.	Pa	cfm	L/s	cfm	L/s	cfm	L/s
.20	50	1640	775	1570	740	1480	700
.30	75	1560	735	1500	710	1430	675
.40	100	1500	710	1440	680	1360	640
.50	125	1400	660	1340	630	1290	610
.60	150	1300	615	1270	600	1230	580
.70	175	1260	595	1200	565	1170	550
.80	200	1160	545	1100	520	1050	495

① For down-flow air volume, add 0.10 in. w.g. (25 Pa) to duct static.

NOTE — All air data is measured external to unit without air filters.

10CHP030 AND 10CHP036 BLOWER PERFORMANCE							
① Horizontal Air Flow							
External Static Pressure		Air Volume at Various Blower Speeds					
		High		Medium		Low	
in. w.g.	Pa	cfm	L/s	cfm	L/s	cfm	L/s
.20	50	1400	660	1160	545	1050	495
.30	75	1350	635	1120	530	1020	480
.40	100	1280	605	1080	510	1000	470
.50	125	1200	565	1030	485	950	450
.60	150	1120	530	980	460	910	430
.70	175	1030	485	900	425	840	395
.80	200	920	435	780	370	750	355

① For down-flow air volume, add 0.10 in. w.g. (25 Pa) to duct static.

NOTE — All air data is measured external to unit without air filters.

10CHP048 AND 10CHP060 BLOWER PERFORMANCE							
① Horizontal Air Flow							
External Static Pressure		Air Volume at Various Blower Speeds					
		High		Medium		Low	
in. w.g.	Pa	cfm	L/s	cfm	L/s	cfm	L/s
.20	50	2150	1015	1920	905	1750	825
.30	75	2100	990	1870	880	1720	810
.40	100	2030	960	1790	845	1650	780
.50	125	1950	920	1730	815	1600	755
.60	150	1875	885	1650	780	1550	730
.70	175	1750	825	1580	745	1480	700
.80	200	1650	780	1500	710	1400	660

① For down-flow air volume, add 0.10 in. w.g. (25 Pa) to duct static.

NOTE — All air data is measured external to unit without air filters.

10GCS PARTS ARRANGEMENT

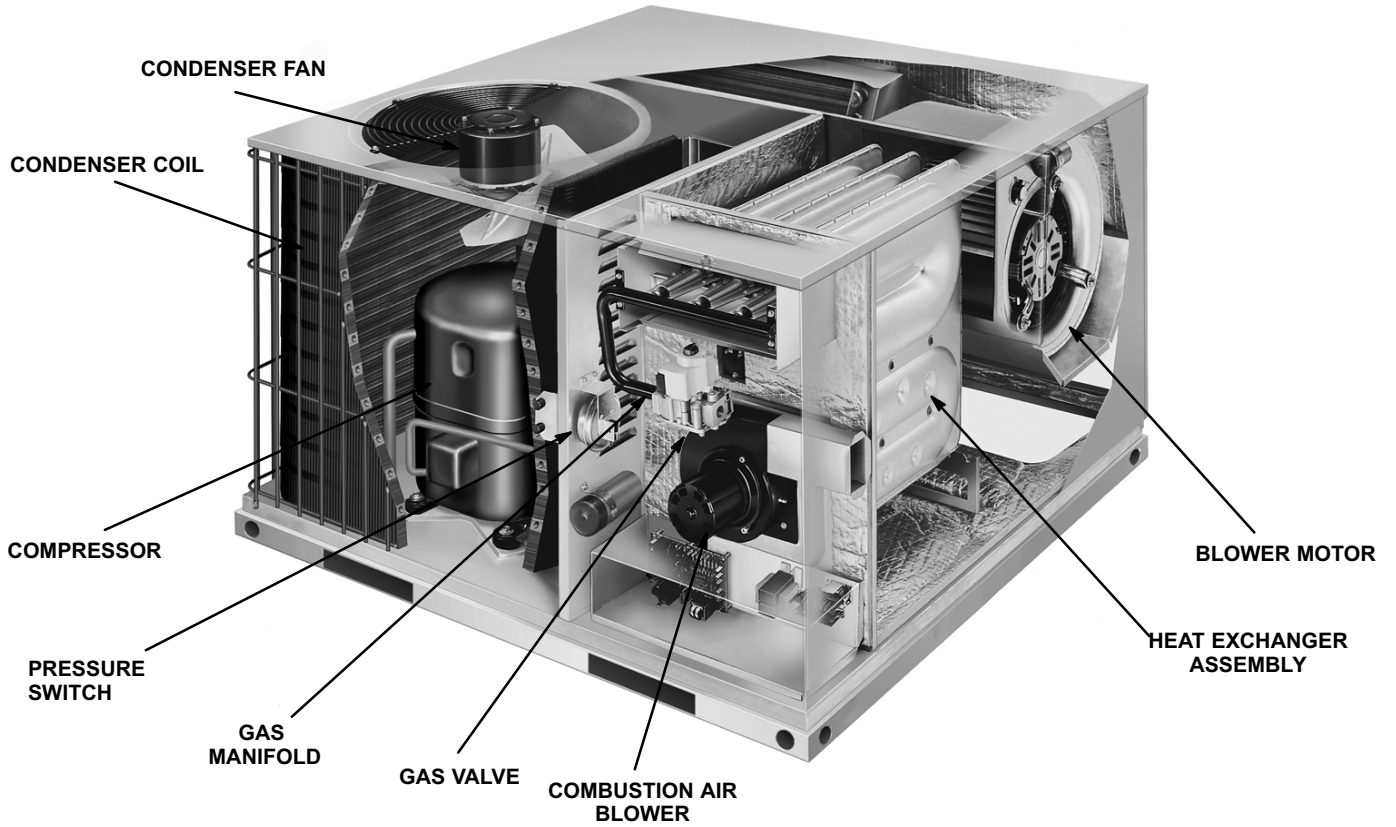

FIGURE 1

10CHA PARTS ARRANGEMENT



FIGURE 2

10CHP PARTS ARRANGEMENT

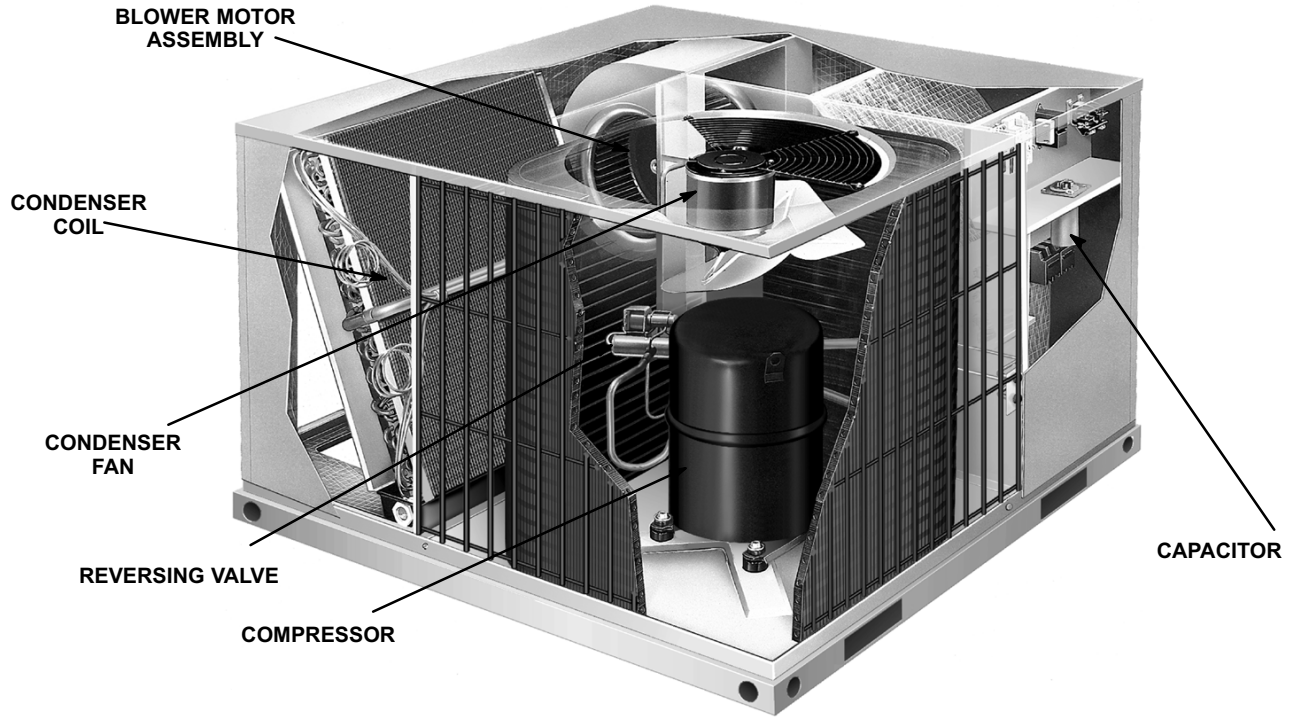

FIGURE 3

10GCS CONTROL BOX

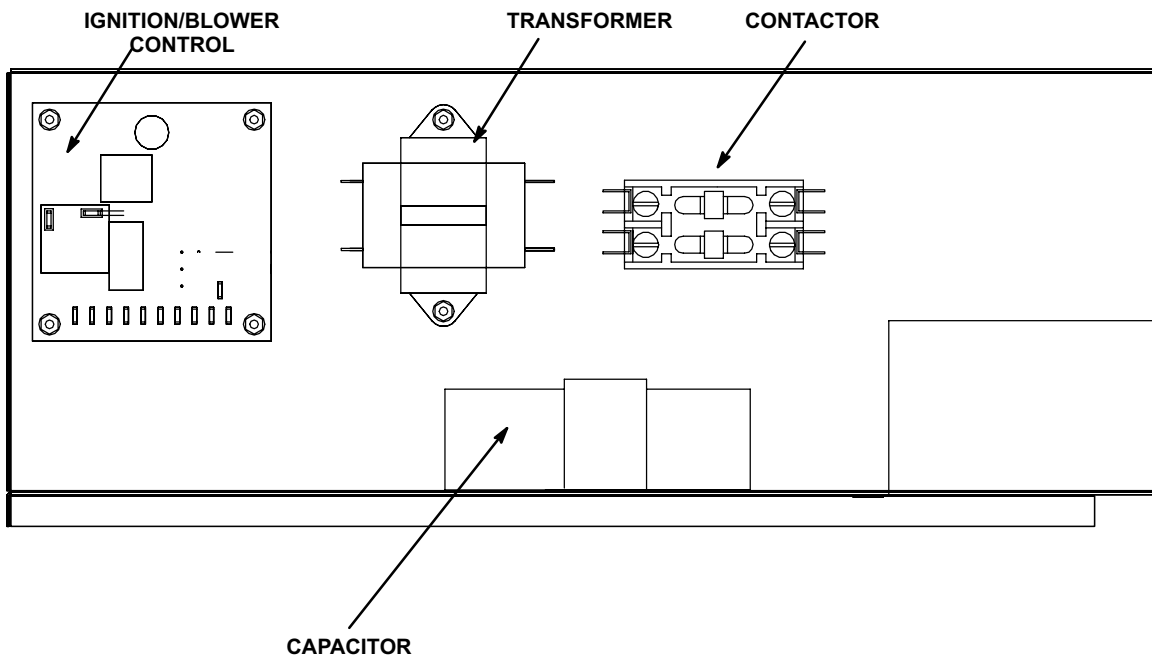

FIGURE 4

10CHA CONTROL BOX

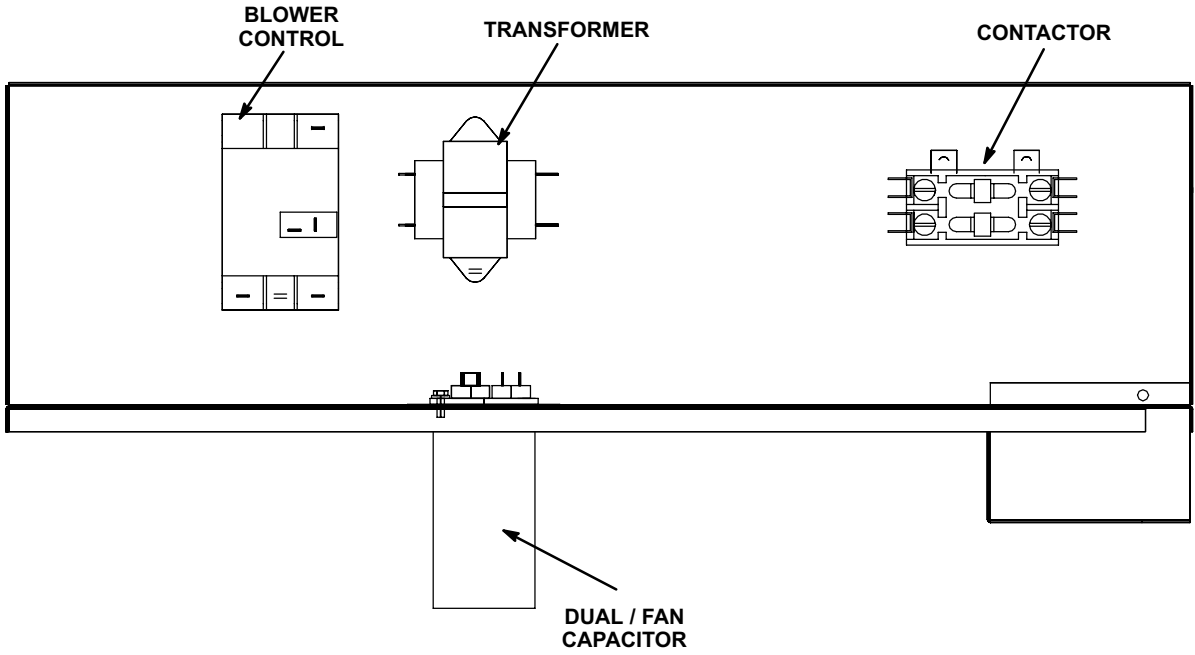

FIGURE 5

10CHP CONTROL BOX

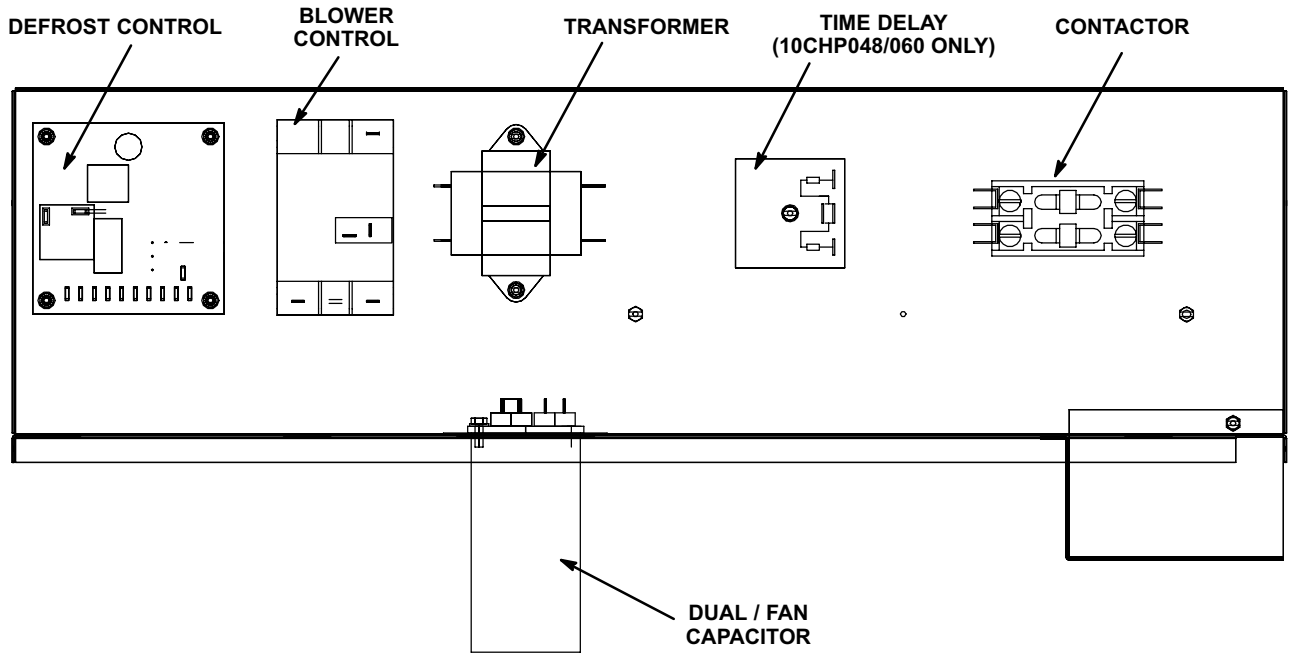

FIGURE 6

I-APPLICATION

GCS,CHA and 10CHP 2 to 5 ton (7.0 to 17.6 kW) units are available in three cabinet sizes. All three models share the same cabinet according to tonnage size (refer to the Engineering Handbook for more specific application data). ALL GCS, CHA and CHP units are single-phase and residential only.

II-UNIT COMPONENTS

10GCS components are shown in figure 1. 10CHA components are shown figure 2. 10CHP components are in figure 3.

A-Control Box Components

10GCS control box components are shown in figure 4. 10CHA components are shown in figure 5. 10CHP components are shown in figure 6.

1-Compressor Contactor K1 (all models)

K1 is a 24VAC to line voltage double-pole contactor, used to energize the compressor and condenser fan in response to thermostat demand.

2-Control Transformer T1 (all models)

All GCS/CHA/CHP series units use a single line voltage to 24VAC transformer mounted in the control box. The transformer supplies power to control circuits in the unit. Transformers use two primary voltage taps as shown in figure 7.

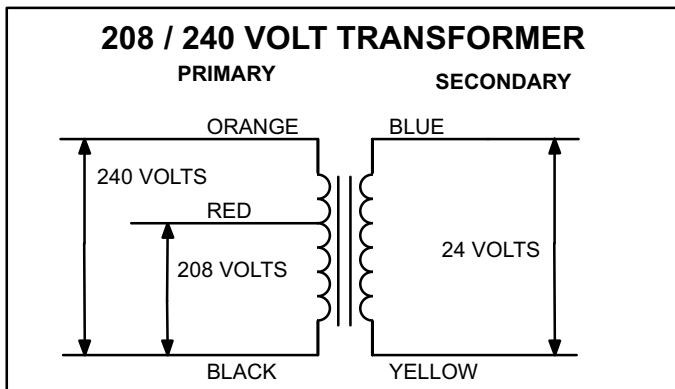

FIGURE 7

3-Dual Capacitor C12 (all models)

The compressor and condensing fan in the GCS/CHA/CHP series units use split capacitor motors. The capacitor is located in the unit control box. A single dual capacitor is used for both the fan motor and the compressor (see unit wiring diagram per respective unit). The fan side and the compressor side of the capacitor have different MFD ratings. GCS and CHA units share the same compressors and dual capacitors. Ratings will be on side of capacitor.

4-Ignition/Blower Control (A3)

All 10GCS series units are equipped with an integrated ignition/blower control (figure 8) which controls ignition, safety circuits, blower operation and fan off timing. The control is a printed circuit board which is divided into two sections, 230 and 24VAC. Table 1 shows jack plug terminal designations.

Ignition control

All 10GCS units use direct spark ignition which is controlled by the control board. On a call for heat the control monitors the combustion air blower pressure switch. The control will not begin the heating cycle if the pressure switch is closed (bypassed). Once the pressure switch is determined to be open, the combustion air blower is energized. When the differential in the pressure switch is great enough, the pressure switch closes and a 30 second pre-purge begins. After the pre-purge period, the gas valve will open and ignition (spark) is attempted for 10 seconds. If the initial attempt for ignition fails, the sequence is repeated two more times. After a total attempt of three trials the board goes into "Watchguard". During watchguard mode, the board will be de-energized for one hour. After one hour the control will repeat the ignition sequence. Watchguard may be manually reset by breaking or remaking thermostat demand.

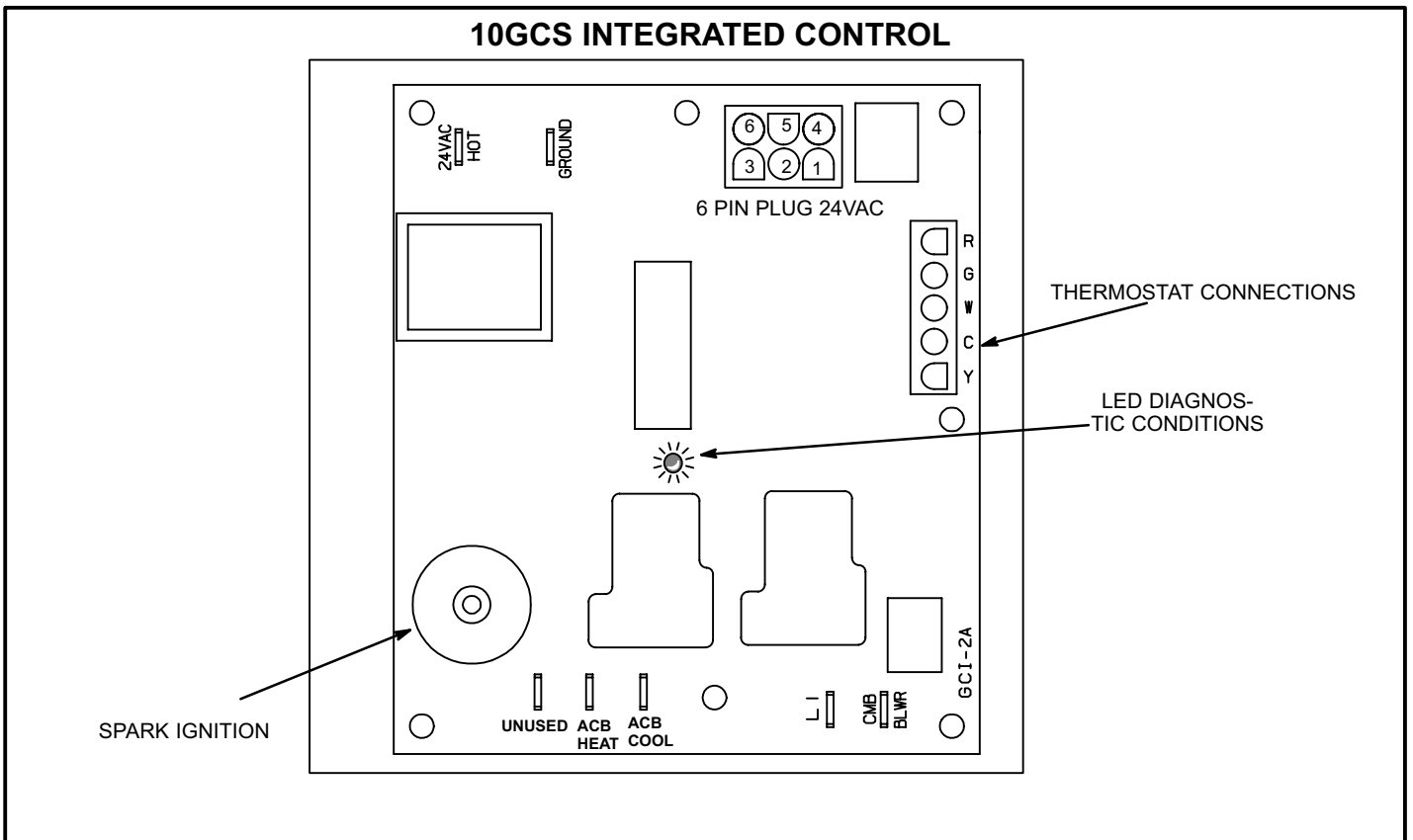

FIGURE 8

Safety Circuits

During the heating cycle the control monitors the safety circuits. If the primary or secondary heating limits open, the control de-energizes the gas valve and combustion air blower while the indoor blower remains energized. When the limit automatically resets the ignition sequence also resets.

The roll-out switch circuit is also monitored by the control. If the switch opens, the control will de-energize the gas valve and the combustion air blower. The unit will remain de-energized until the switch is manually reset.

Blower Operation / Fan Off Time

Fan "off" timing (time that the blower operates after the heat demand is satisfied) is factory set at 120 seconds and is not adjustable. The fan "off" time is initiated after a heating demand but not after a cooling demand. Fan "on" time is factory set at 30 seconds following the opening of the gas valve and is not adjustable.

Table 1

CONTROL BOARD JACK/PLUG TERMINAL DESIGNATIONS	
PIN #	FUNCTION
1	Rollout Switch Out
2	Pressure Switch
3	Gas Valve Out
4	Gas Valve Common
5	High Limit Out
6	Rollout Switch Return

Thermostat Connection

Thermostat wires are connected to terminals found on the control board. The terminals are clearly marked with the corresponding thermostat designation. (See figure 8)

Troubleshooting

The control board is equipped with a diagnostic green LED to indicate mode of unit. The codes are given in table 2.

Table 2

CONTROL BOARD DIAGNOSTIC CODES	
Slow Flash	Normal operation no call for heat
Fast Flash	Normal operation call for heat
2 Flashes	Lockout-failed to detect or sustain flame
3 Flashes	Pressure switch open or closed/ Auxiliary limit open.*
4 Flashes	High limit or Rollout switch open
5 Flashes	Flame sensed and gas valve not energized
Steady Flash	Circuit board self-check failure or ignition/blower control wired incorrectly

*This LED code will not appear until after the indoor blower has been de-energized for for approximately 120 seconds.

5- Blower Control A15 (CHA, CHP Only)

Blower control A15 is found in the control box of all CHA/10CHP units. The control is responsible for energizing the blower in response to thermostat demand. The control has a **set** on delay timing of less than 5 seconds and a **set** off timing of 90 seconds \pm 20%. These timings are not adjustable.

6-Time Delay DL8 (optional all models)

An optional feature on all GCS/CHA/10CHP units is a time delay relay. DL8 provides a 5-minute delay between the compressor cycle. This delay prevents compressor short-cycling which could lead to failure, due to rapid on-off thermostat mode selection.

7-Defrost Control CMC1 (CHP Only)

If outdoor ambient conditions are such that frost forms on the outdoor coil, the defrost control monitors the need for and initiates and terminates defrost cycles to maintain system performance. The defrost control is time/temperature initiated and temperature terminated with a maximum defrost time (time-out) of 10 minutes. Time between defrost cycles is pre-set at 60 minute intervals at the factory, but can be field adjusted between 30, 60 or 90 minutes. See figure 9 for field adjustment of defrost timing.

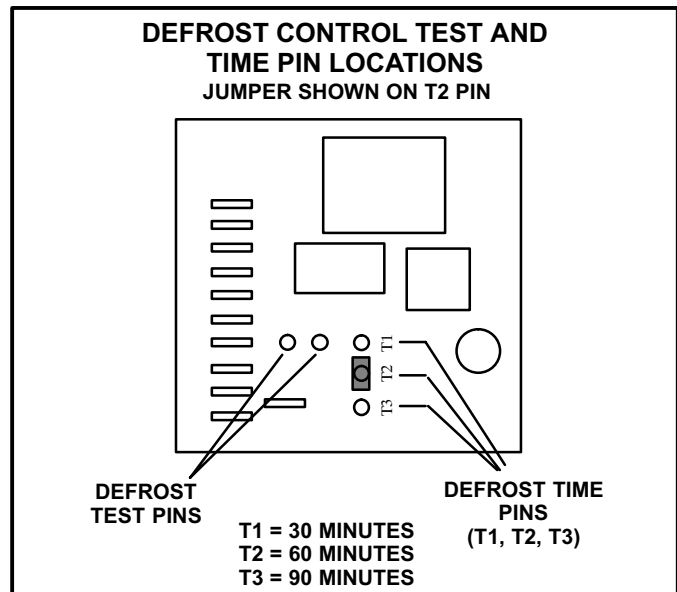

FIGURE 9

The defrost control initiates a defrost cycle if time period has elapsed and the defrost sensor detects a temperature below freezing. At the start of defrost cycle, the defrost control energizes the reversing valve solenoid, shifting the reversing valve and de-energizing the outdoor fan. The defrost relay also energizes auxiliary heat for increased comfort during defrost. The unit will remain in the defrost mode until the defrost sensor has determined that the frost has been removed from the coil or a 10 minute time period has elapsed.

The defrost control is also equipped with a set of test pins to aid in troubleshooting of the defrost system. The following is a brief outline of the testing of the defrost system.

Defrost sensor closes at 32° F or below. If temperatures are such that switch is not closed, jumper between defrost sensor terminals on defrost control.

Start system in Heating Operation.

Jumper test pins. A 1/4" quick connect terminal crimped onto a solid wire or brazing rod works well for test jumper. Closing test pins speeds up time interval by a factor of 256.

DEFROST CONTROL TEST CYCLE TIME

T1-30 minutes	7 seconds
T2-60 minutes	14 seconds
T3-90 minutes	21 seconds

After closing test pins and appropriate cycle time has elapsed, the reversing valve should shift to defrost mode and outdoor fan should stop. After 2 seconds of defrost operation, reversing valve should shift back to heating operation and outdoor fan should start.

B-Gas Components (GCS Only)

1-Auto Reset Limit Control S10

All 10GCS units are equipped with closed face, auto reset, high temperature limit. S10 protects the unit from high temperature operation. It is located on the heating vest panel just below the burner box. The N.C. contacts are actuated by a bi-metal shim when temperature in the heating compartment is high enough. When the N.C. contacts open, the ignition control and gas valve are de-energized shutting down the unit except for the main blower. The limit automatically resets when unit temperature returns to normal. All limits are 3" in length with varying setpoints. Limit setpoints will be printed on side.

⚠ IMPORTANT

Limit replacement must be of exact length and setpoint. Different length or setpoint can result in unsafe operation of unit.

2-Rollout Switch S47

Rollout switch S47 is a high temperature limit located on the burner box. The limit is a N.C. manual reset switch connected in series with the ignition control A3. When S47 senses flame rollout (opens), ignition control and gas valve are de-energized. The switch is factory set at 400°F and cannot be adjusted. S47 can be manually reset when temperatures allow.

⚠ IMPORTANT

Rollout Switch must be of exact setpoint. Different setpoint can result in unsafe operation of unit.

3-Auto Reset Auxiliary Limit S21

S21 is a high temperature control located on the blower scroll (see figure10). The switch is an automatic reset disc with a bi-metal shim that actuates on temperature rise. S21 is wired in series with primary limit S10. When the N.C. contacts open the ignition control and gas valve are de-energized. The safety switch protects against high temperatures which would occur if circulating blower B3 fails. The switch will automatically reset when temperatures in the blower housing return to normal. Limit setpoints will be printed on side.

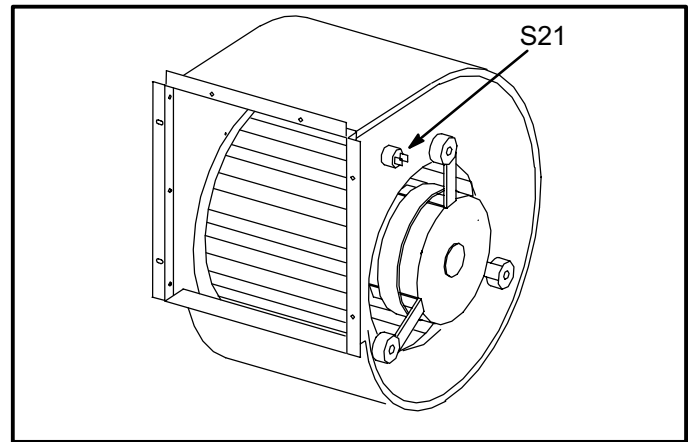

FIGURE 10

4-Combustion Air Pressure Switch S18

The combustion air pressure switch S18 is a SPST N.O. differential pressure switch, which monitors combustion air blower operation. The switch is wired in series with ignition board A3. When the combustion air blower begins operation and pressure drop reaches .17" w.c. across the switch, the contacts close and ignition can be initiated.

5-Electrode/Flame Sensor

The electrode/sensor is used for ignition and is located in the left-hand mounting hole. The location varies by model. 10GCS-1 models will have a single bracket with the electrode /sensor. 10GCS-2 models will have a split electrode /sensor. The electrode tip protrudes into the flame envelope of the adjacent burner. If the blower/ignition control A3 does not receive signal from the electrode/flame sensor indicating that the burners have established flame, the main gas valve GV1 will close after the 10-second sensing interval built into the ignition control A3. To measure the flame current, follow the procedure below:

- 1- Disconnect power to unit.
- 2- Remove lead from sensing electrode and install a micro-amp meter in series between the sensing electrode and sensing lead.
- 3- Reconnect power and adjust thermostat for heating demand.
- 4- When flame is established, meter reading should be between 1 and 5 microamps. Drop-out signal is .45 amps.
- 5- Disconnect power to unit before disconnecting meter. Make sure sensor wire is securely reconnected before reconnecting power to unit.

6-Combustion Air Blower B6

Combustion air blower B6 provides fresh air to the burners while clearing exhaust gases out of the heat exchanger clams. The blower begins operating immediately upon receiving a thermostat demand and is de-energized immediately when thermostat demand is satisfied. Combustion air blower specifications are shown in table 3. All combustion air blower motors are sealed and cannot be oiled.

Table 3

COMBUSTION AIR BLOWER				
Unit Input Btuh	Volts/Phase	HP	RPM	Bearings
50K 75K 100K 125K 150K	208/ 230/1	1/30	3000	Ball

7-Gas Valve GV1

The 10GCS uses a gas valve manufactured by Honeywell. The valves are internally redundant to assure safety shutoff. If the valve must be replaced, the same valve type must be used. 24VAC terminals and gas control knob are located on top of the valve. All terminals on the gas valve are connected to wires going to the ignition board A3. 24VAC applied to the "MV" on the valve opens the valve. A regulator adjustment screw is located on the valve. See figure 11 .

An LP changeover kit (Lennox part #42K91) is available. The kit includes burner orifices and a regulator conversion kit. Follow kit instructions when converting unit to LP.

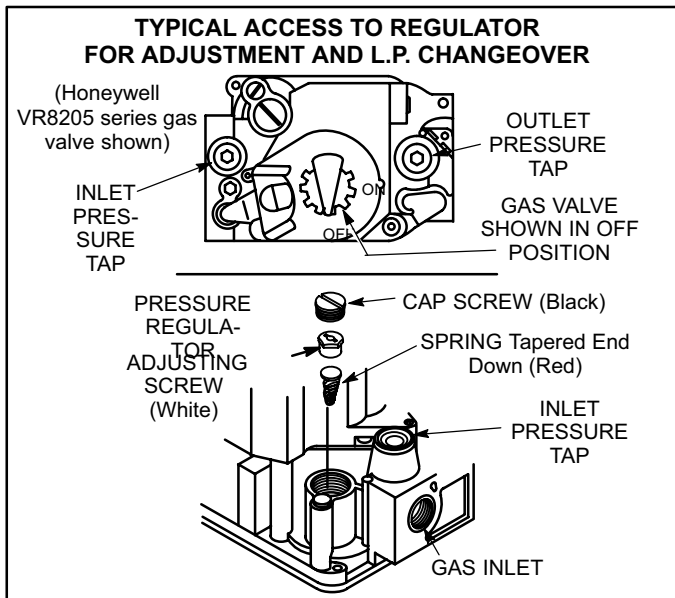

FIGURE 11

8-Clamshell Heat Exchanger

The 10GCS units use a aluminized steel tapered S-curve heat exchanger. Heat is transferred to the air stream from all surfaces of the heat exchanger. The combustion air blower pulls fresh air through the burner box. This air is mixed with gas in the burner Venturi. The gas/air mixture is then burned at the entrance of each clam shell. Combustion gases are pulled through the heat exchanger and travel through the exhaust vent.

9-Burners/Orifices

All 10GCS units use inshot burners. A flame retention ring located in the burner keeps flame from lifting off the burner. All 10GCS units use orifices that are precisely matched to the burner input. Each burner is supported by the orifice but can easily be removed for service. If service is necessary, the following instructions should be applied.

- 1- Close main manual shutoff valve and shut off all power to the unit.
- 2- Open the union fitting in the gas supply line just upstream of the unit gas valve and downstream from the manual shutoff valve.
- 3- Remove the four screws, two on the side and two on the bottom, that mount the burner rack assembly to the burner plate.
- 4- Disconnect wiring to the gas valve and the electrode/flame sensor. Remove the burner rack assembly from the unit by pulling back. Burners and gas orifices are now accessible to service.
- 5- Reverse the above procedure to replace the assembly. Make sure that burners are level and centered into each burner's corresponding heat exchanger tube.

III-Evaporator Blower B3 & Capacitor C4 (all models)

All GCS/CHA/10CHP units use single-phase motors. A single run capacitor is mounted on the blower housing. Capacitor ratings will be printed on the side. See wiring diagram for factory set speed tap and "ELECTRICAL DATA " section in this manual or blower nameplate for blower ratings.

IV-Electric Heat (optional CHA/CHP only)

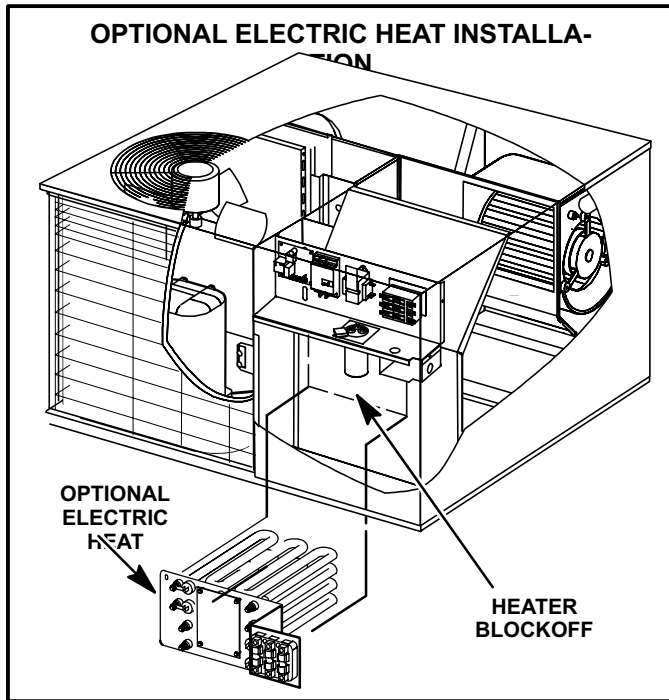

FIGURE 12

A-Matchups and Ratings

Tables 5 through 8 show all approved ECH29 matchups and ratings.

B-Electric Heat Components

See figure 13 for electric heat parts arrangement.

1-Primary Limit S15

S15 is a N.C. auto-reset high temperature limit located on the electric heat vest panel. Each heating element is wired in series with a high temperature limit. When S15 opens, the corresponding heating element is de-energized. All other heating elements remain energized. S15 automatically closes when temperatures return to normal.

2-Thermal Fuse F5

All ECH29 series units use a high temperature cutoff fuse connected in series with each element. The fuse provides secondary high temperature protection to each element. The fuses are non-resettable fusible links which must be replaced after being tripped.

3-Electric Heat Sequencer Relays K32, K33, K34, K35

Relays K32, K33, K34 and K35 are N.O. sequencer relays with a resistive element for a coil and bi-metal disk which actuates the contacts. The relays are located on the electric heat vest panel and are energized by a 24V heating demand (W1 and W2) via jack/plug P2 which is used to connect electric heat to the blower control circuit. When energized, the internal resistance heats the bi-metal disk causing the contacts to close. When the relay is de-energized the disk cools and the contacts open. The relays energize different stages of heat, as well as the blower. The blower is always first on and last off.

4-Terminal Strip TB2 ECH29-05, -07, -10

For electric heat sections without circuit breakers or fuses, line voltage connections are made to terminal strip TB2.

5-Heating Element HE1 through HE5

Heating elements are composed of helix-wound bare nichrome wire exposed directly to the air stream. The elements are supported by insulators mounted to the wire frame. Each element is energized independently by a corresponding relay located on the heat vest panel. Once energized, heat transfer is instantaneous. High temperature protection is provided by a high temperature limit.

6-Circuit Breaker CB1, CB2 and CB3 ECH29-15, -20, -25

Line voltage connections are made to circuit breakers CB1, CB2 and CB3 in electric heat sections with circuit breakers. Table 4 shows amp rating for each circuit breaker used. All electric heat sections use two-pole circuit breakers.

Table 4

ECH29 Circuit Breakers			
UNIT	CB1 AMPS	CB2 AMPS	CB3 AMPS
ECH29-15-1-P	60 AMPS	30 AMPS	N/A
ECH29-20-1-P	60 AMPS	60 AMPS	N/A
ECH29-25-1-P	60 AMPS	60 AMPS	30 AMPS

Table 5 Electric Heat 10CHP UNITS

Packaged Unit Model No.	Electric Heater Model No. & Net Weight	kW Input	No. of Steps & Phase	Volts Input	Electric Heat kW Input	Electric Heat Btuh Input	Heater Only †Minimum Circuit Ampacity	
							Circuit 1	Circuit 2
10CHP-024	ECH29-05 (71K18) (4 lbs.) (2 kg)	5	1 step (1 phase)	208	3.8	12,800	25.8	----
				220	4.2	14,300	27.1	----
				230	4.6	15,700	28.3	----
				240	5.0	17,100	29.3	----
	ECH29-07 (74K64) (5 lbs.) (2 kg)	7	1 step (1 phase)	208	5.3	18,100	34.8	----
				220	5.9	20,100	36.7	----
				230	6.4	21,800	38.0	----
				240	7.0	23,900	39.7	----
	ECH29-10 (71K19) (5 lbs.) (2 kg)	10	1 step (1 phase)	208	7.5	25,600	48.4	----
				220	8.4	28,700	51.1	----
				230	9.2	31,400	53.3	----
				240	10.0	34,100	55.3	----
10CHP-030 10CHP-036	ECH29-05 (71K18) (4 lbs.) (2 kg)	5	1 step (1 phase)	208	3.8	12,800	25.8	----
				220	4.2	14,300	27.1	----
				230	4.6	15,700	28.3	----
				240	5.0	17,100	29.3	----
	ECH29-07 (74K64) (5 lbs.) (2 kg)	7	1 step (1 phase)	208	5.3	18,100	34.8	----
				220	5.9	20,100	36.7	----
				230	6.4	21,800	38.0	----
				240	7.0	23,900	39.7	----
	ECH29-10 (71K19) (5 lbs.) (2 kg)	10	1 step (1 phase)	208	7.5	25,600	48.4	----
				220	8.4	28,700	51.1	----
				230	9.2	31,400	53.3	----
				240	10.0	34,100	55.3	----
	ECH29-15 (71K20) (18 lbs.) (9 kg)	15	1 step (1 phase)	208	11.3	38,600	48.4	22.6
				220	12.6	43,000	51.1	23.8
				230	13.8	47,100	53.3	25.0
				240	15.0	51,200	55.3	26.0
	ECH29-20 (71K21) (20 lbs.) (9 kg)	20	1 step (1 phase)	208	15.0	51,200	48.4	45.1
				220	16.8	57,300	51.1	47.8
				230	18.4	62,800	53.3	50.0
				240	20.0	68,300	55.3	52.1

†Refer to National or Canadian Electrical Code manual to determine wire, fuse and disconnect size requirements. Use wires suitable for at least 167°F (75°C).

Table 6 Electric Heat 10CHP Units

Packaged Unit Model No.	Electric Heater Model No. & Net Weight	kW Input	No. of Steps & Phase	Volts Input	Electric Heat kW Input	Electric Heat Btuh Input	Heater Only †Minimum Circuit Ampacity		
							Circuit 1	Circuit 2	Circuit 3
10CHP-042	ECH29-05 (71K18) (4 lbs.) (2 kg)	5	1 step (1 phase)	208	3.8	12,800	26.8	----	----
				220	4.2	14,300	28.1	----	----
				230	4.6	15,700	29.3	----	----
				240	5.0	17,100	30.3	----	----
	ECH29-07 (74K64) (5 lbs.) (2 kg)	7	1 step (1 phase)	208	5.3	18,100	35.8	----	----
				220	5.9	20,100	37.7	----	----
				230	6.4	21,800	39.0	----	----
				240	7.0	23,900	40.7	----	----
	ECH29-10 (71K19) (5 lbs.) (2 kg)	10	1 step (1 phase)	208	7.5	25,600	49.4	----	----
				220	8.4	28,700	52.1	----	----
				230	9.2	31,400	54.3	----	----
				240	10.0	34,100	56.3	----	----
	ECH29-15 (71K20) (18 lbs.) (8 kg)	15	1 step (1 phase)	208	11.3	38,600	49.4	22.6	----
				220	12.6	43,000	52.1	23.8	----
				230	13.8	47,100	53.3	25.0	----
				240	15.0	51,200	56.3	26.0	----
ECH29-20 (71K21) (20 lbs.) (9 kg)	20	1 step (1 phase)	208	15.0	51,200	49.4	45.1	----	
			220	16.8	57,300	52.1	23.8	----	
			230	18.4	62,800	53.3	25.0	----	
			240	20.0	68,300	56.3	52.1	----	
10CHP-048 10CHP-060	ECH29-10 (71K19) (5 lbs.) (2 kg)	10	1 step (1 phase)	208	7.5	25,600	51.4	----	----
				220	8.4	28,700	54.1	----	----
				230	9.2	31,400	56.3	----	----
				240	10.0	34,100	58.4	----	----
	ECH29-15 (71K20) (18 lbs.) (8 kg)	15	1 step (1 phase)	208	11.3	38,600	51.4	22.6	----
				220	12.6	43,000	54.1	23.8	----
				230	13.8	47,100	56.3	25.0	----
				240	15.0	51,200	58.4	26.0	----
	ECH29-20 (71K21) (20 lbs.) (9 kg)	20	1 step (1 phase)	208	15.0	51,200	51.4	45.1	----
				220	16.8	57,300	54.1	47.8	----
				230	18.4	62,800	56.3	50.0	----
				240	20.0	68,300	58.4	52.1	----
	ECH29-25 (71K22) (20 lbs.) (9 kg)	25	1 step (1 phase)	208	18.8	64,200	51.7	45.1	22.6
				220	21.0	71,700	54.1	47.8	23.8
				230	23.0	78,500	56.3	50.0	25.0
				240	25.0	85,300	58.4	52.1	26.0

†Refer to National or Canadian Electrical Code manual to determine wire, fuse and disconnect size requirements. Use wires suitable for at least 167°F (75°C).

Table 7 Electric Heat 10CHA Units

Packaged Unit Model No.	Electric Heater Model No. & Net Weight	kW Input	No. of Steps & Phase	Volts Input	Electric Heat kW Input	Electric Heat Btuh Input	Heater Only Ⓜ Minimum Circuit Ampacity	
							Circuit 1	Circuit 2
10CHA-024	ECH29-05 (71K18) (4 lbs.) (2 kg)	5	1 step (1 phase)	208	3.8	12,800	25.8	----
				220	4.2	14,300	27.1	----
				230	4.6	15,700	28.3	----
				240	5.0	17,100	29.3	----
	ECH29-07 (74K64) (5 lbs.) (2 kg)	7	1 step (1 phase)	208	5.3	18,100	34.8	----
				220	5.9	20,100	36.7	----
				230	6.4	21,800	38.0	----
				240	7.0	23,900	39.7	----
	ECH29-10 (71K19) (5 lbs) (2 kg)	10	1 step (1 phase)	208	7.5	25,600	48.4	----
				220	8.4	28,700	51.1	----
				230	9.2	31,400	53.3	----
				240	10.0	34,100	55.3	----
10CHA-030 10CHA-036	ECH29-05 (71K18) (4 lbs.) (2 kg)	5	1 step (1 phase)	208	3.8	12,800	25.8	----
				220	4.2	14,300	27.1	----
				230	4.6	15,700	28.3	----
				240	5.0	17,100	29.3	----
	ECH29-07 (74K64) (5 lbs.) (2 kg)	7	1 step (1 phase)	208	5.3	18,100	34.8	----
				220	5.9	20,100	36.7	----
				230	6.4	21,800	38.0	----
				240	7.0	23,900	39.7	----
	ECH29-10 (71K19) (5 lbs) (2 kg)	10	1 step (1 phase)	208	7.5	25,600	48.4	----
				220	8.4	28,700	51.1	----
				230	9.2	31,400	53.3	----
				240	10.0	34,100	55.3	----
	ECH29-15 (71K20) (17 lbs.) (8 kg)	15	1 step (1 phase)	208	11.3	38,600	48.4	22.6
				220	12.6	43,000	51.1	23.8
				230	13.8	47,100	53.3	25.0
				240	15.0	51,200	55.3	26.0
	ECH29-20 (71K21) (20 lbs.) (9 kg)	20	1 step (1 phase)	208	15.0	51,200	48.4	45.1
				220	16.8	57,300	51.1	47.8
				230	18.4	62,800	53.3	50.0
				240	20.0	68,300	55.3	52.1
10CHA-042	ECH29-05 (71K18) (4 lbs.) (2 kg)	5	1 step (1 phase)	208	3.8	12,800	26.8	----
				220	4.2	14,300	28.1	----
				230	4.6	15,700	29.3	----
				240	5.0	17,100	30.3	----
	ECH29-07 (74K64) (5 lbs.) (2 kg)	7	1 step (1 phase)	208	5.3	18,100	35.8	----
				220	5.9	20,100	37.7	----
				230	6.4	21,800	39.0	----
				240	7.0	23,900	40.7	----
	ECH29-10 (71K19) (5 lbs) (2 kg)	10	1 step (1 phase)	208	7.5	25,600	49.4	----
				220	8.4	28,700	52.1	----
				230	9.2	31,400	54.3	----
				240	10.0	34,100	56.3	----
	ECH29-15 (71K20) (17 lbs.) (8 kg)	15	1 step (1 phase)	208	11.3	38,600	49.4	22.6
				220	12.6	43,000	52.1	23.8
				230	13.8	47,100	53.3	25.0
				240	15.0	51,200	56.3	26.0
	ECH29-20 (71K21) (20 lbs.) (9 kg)	20	1 step (1 phase)	208	15.0	51,200	49.4	45.1
				220	16.8	57,300	52.1	23.8
				230	18.4	62,800	53.3	25.0
				240	20.0	68,300	56.3	52.1

Ⓜ Refer to National or Canadian Electrical Code manual to determine wire, fuse and disconnect size requirements. Use wires suitable for at least 167°F (75°C).

Table 8 Electric Heat 10CHA Units

Packaged Unit Model No.	Electric Heater Model No. & Net Weight	kW Input	No. of Steps & Phase	Volts Input	Electric Heat kW Input	Electric Heat Btuh Input	Heater Only Minimum Circuit Ampacity		
							Circuit 1	Circuit 2	Circuit 3
10CHA-048 10CHA-060	ECH29-10 (71K19) (5 lbs) (2 kg)	10	1 step (1 phase)	208	7.5	25,600	51.4	----	----
				220	8.4	28,700	54.1	----	----
				230	9.2	31,400	56.3	----	----
				240	10.0	34,100	58.4	----	----
	ECH29-15 (71K20) (18 lbs.) (8 kg)	15	1 step (1 phase)	208	11.3	38,600	51.4	22.6	----
				220	12.6	43,000	54.1	23.8	----
				230	13.8	47,100	56.3	25.0	----
				240	15.0	51,200	58.4	26.0	----
	ECH29-20 (71K21) (20 lbs.) (9 kg)	20	1 step (1 phase)	208	15.0	51,200	51.4	45.1	----
				220	16.8	57,300	54.1	47.8	----
				230	18.4	62,800	56.3	50.0	----
				240	20.0	68,300	58.4	52.1	----
	ECH29-25 (71K22) (20 lbs.) (9 kg)	25	1 step (1 phase)	208	18.8	64,200	51.7	45.1	22.6
				220	21.0	71,700	54.1	47.8	23.8
				230	23.0	78,500	56.3	50.0	25.0
				240	25.0	85,300	58.4	52.1	26.0

Refer to National or Canadian Electrical Code manual to determine wire, fuse and disconnect size requirements. Use wires suitable for at least 167°F (75°C).

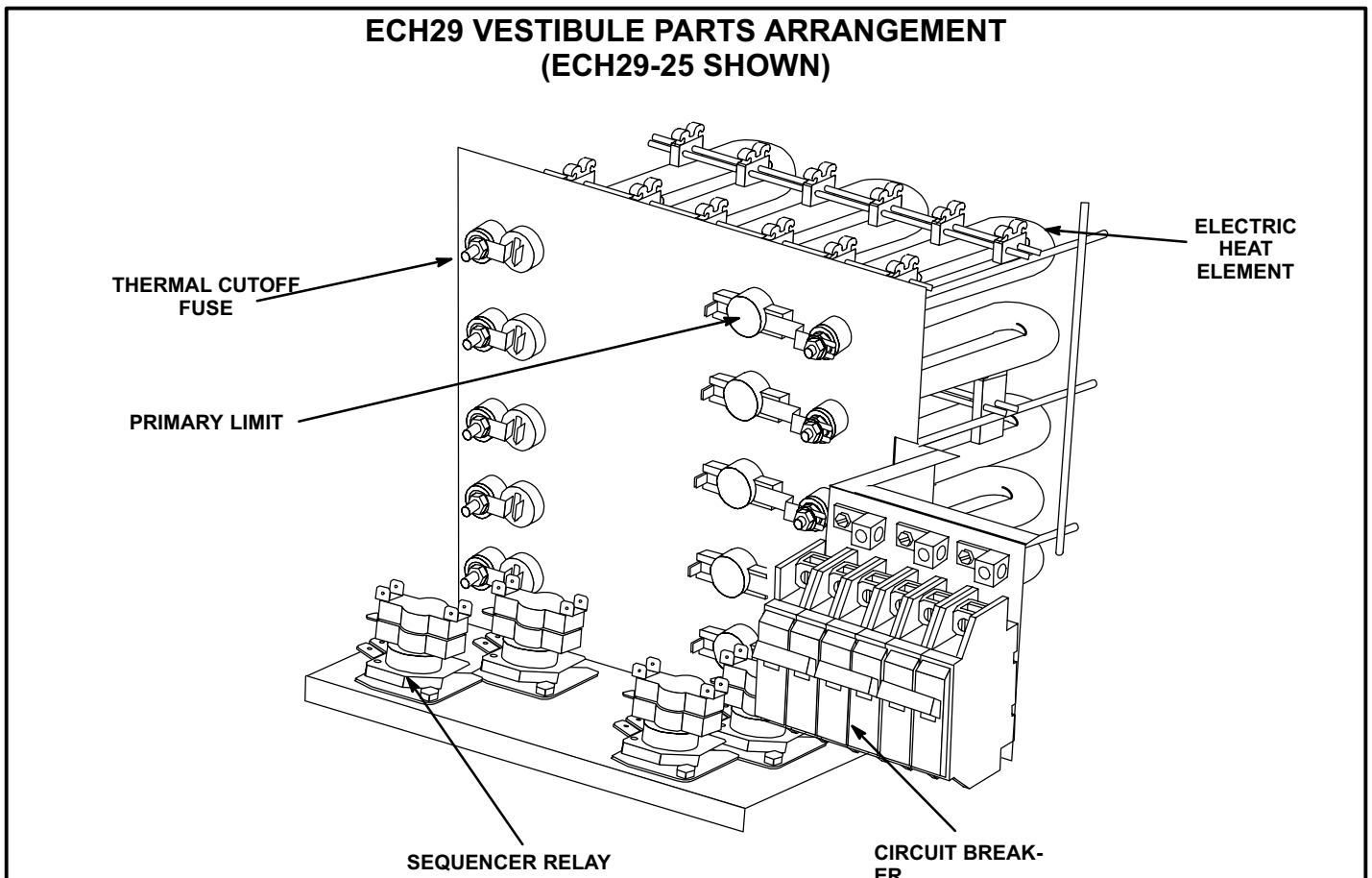

FIGURE 13

V-Cooling Components

A-Compressor B1 (all models)

All GCS/CHA/CHP units use a high efficiency reciprocating compressor except 10CHP-048 and the 10CHP-060 which use a scroll compressor. Compressors are energized by contactors found in unit control box. Compressor specifications are given in "ELECTRICAL DATA" section in this manual or compressor nameplate.

WARNING

Electrical shock hazard. Compressor must be grounded. Do not operate without protective cover over terminals. Disconnect power before removing protective cover. Discharge capacitors before servicing unit. Failure to follow these precautions could cause electrical shock resulting in injury or death.

B-Condenser Fan B4 (all models)

All GCS/CHA/CHP units use single phase condenser fans. Specifications for the condenser fans are at the front of this manual. See table of contents.

C-Reversing Valve L1 (CHP only)

Reversing valve L1 has a 24volt solenoid coil used to reverse refrigerant flow during unit operation in all 10CHP units. The reversing valve is connected in the vapor lines of the refrigerant circuit. The reversing valve coil is energized during cooling demand and during defrost.

D-Accumulator (CHP only)

All 10CHP units have an accumulator. The accumulator traps and evaporates all liquid refrigerant and prevents liquid refrigerant from entering the compressor.

E-Filter Drier (CHP only)

All 10CHP units have a filter drier in the liquid line. The drier removes contaminants and moisture from the system.

F-Defrost Thermostat Switch S6 (CHP only)

Defrost thermostat switch S6 is a S.P.S.T. N.O. switch which closes on temperature fall (initiating defrost). The switch is located on the distributor assembly at the outdoor coil inlet. The switch monitors the outdoor coil suction temperature to determine when defrost is needed. When the outdoor coil suction temperature falls to $32^{\circ}\text{F} \pm 4^{\circ}\text{F}$ ($0^{\circ}\text{C} \pm 2.2^{\circ}\text{C}$) the switch closes (initiating defrost after minimum run times of 30, 60, or 90 minutes). The switch will open when the temperature rises to $55^{\circ}\text{F} \pm 5^{\circ}\text{F}$ ($12.7^{\circ}\text{C} \pm 2.8^{\circ}\text{C}$).

G-Low Ambient Control Kit (optional all models)

The low ambient control kit is designed to permit the unit to operate during low ambient conditions. Low evaporator temperatures and liquid flood-back can occur if a sufficient condensing pressure is not maintained. The control cycles the condenser fan B4 to maintain high pressures. The control set-points are adjustable. The recommended settings are 300 PSIG cut in pressure with a 100 PSIG differential. When outdoor temperatures are cool, B4 will cycle on and off to maintain a discharge pressure between 200 and 300 PSIG.

H-High Pressure Switch (optional all models)

The high pressure switch is an auto-reset N.C. switch that opens on pressure rise. This switch is an optional feature for all models. The switch is wired in series with the compressor contactor K1 and is located on the discharge line. When discharge pressure rises to 450 psig (3102 kPa) the switch opens and the compressor is de-energized. When discharge pressure drops to 250 psig (1723 kPa) the pressure switch closes.

VI-Charging

A-10CHP

For maximum performance of this heat pump system, the operating temperatures and pressures should be checked and superheat determined at Standard ARI test conditions of 82°F outdoor - 80°F indoor dry bulb/67°F wet bulb. If superheat measured deviates from values in table 9, refrigerant charge should be adjusted accordingly for maximum performance.

Verify system performance using table 10 or table 11 as a general guide. These tables should not be used for charging the unit. Minor variations in these pressures may be expected due to differences in installations. Significant differences could mean that the system is not properly charged or that a problem exists with some component in the system. Used carefully, this table could serve as a useful service guide. Table 10 should be used when unit is charged during the heating

mode. If outdoor ambient is below 45°F, run unit through defrost cycle first, wait 15 minutes for system pressures to stabilize, then measure pressures. Data in table 10 is based on 70°F dry bulb return air. Data in table 11 is based on 80°F dry bulb / 87°F wet bulb return air. Allow unit operation to stabilize before taking pressure readings.

**TABLE 9
10CHP SUCTION SUPERHEAT TABLE**

UNIT MODEL NO.	SUCTION SUPERHEAT 82°F OD 80°F IDDB / 67°F IDWB
10CHP-024	18 - 20°
10CHP-030	17 - 19°
10CHP-036	17 - 19°
10CHP-042	18 - 20°
10CHP-048	12 - 14°
10CHP-060	12 - 14°

**TABLE 10
NORMAL OPERATING PRESSURES -- HEATING MODE**

70°F db RETURN AIR		AIR TEMPERATURE ENTERING OUTDOOR COIL (°F)												
MODEL	PRESSURE	0°	5°	10°	15°	20°	25°	30°	35°	40°	45°	50°	55°	60°
10CHP-024	SUCTION	19	23	27	31	35	38	42	45	49	53	57	51	65
10CHP-030		18	22	25	29	33	37	41	45	49	52	56	60	65
10CHP-036		19	23	25	30	34	38	41	45	48	51	55	59	63
10CHP-042		18	21	25	28	32	38	40	44	48	51	55	59	63
10CHP-048		17	18	22	25	27	29	31	31	41	49	53	57	62
10CHP-060		17	18	23	26	28	30	32	35	48	55	59	65	69
10CHP-024	LIQUID	138	145	153	160	170	180	190	200	206	216	225	235	244
10CHP-030		139	146	154	161	170	178	186	197	205	212	221	230	239
10CHP-036		140	147	155	162	170	178	186	194	200	205	214	222	230
10CHP-042		138	145	153	160	170	180	190	200	209	217	226	236	245
10CHP-048		139	140	150	157	162	171	182	197	215	235	249	255	265
10CHP-060		160	175	187	200	210	221	225	235	244	254	256	279	291

**TABLE 11
NORMAL OPERATING PRESSURES -- COOLING MODE**

80°F db / 67°F wb RETURN AIR		AIR TEMPERATURE ENTERING OUTDOOR COIL (°F)											
MODEL	PRESSURE	65°	70°	75°	80°	82°	85°	90°	95°	100°	105°	110°	115°
10CHP-024	SUCTION	68	70	75	78	81	82	84	86	89	91	94	96
10CHP-030		68	70	74	78	80	80	81	82	84	87	89	91
10CHP-036		64	70	75	81	83	84	85	87	90	93	95	98
10CHP-042		69	73	76	80	81	82	83	85	88	91	93	96
10CHP-048		74	77	79	80	81	82	82	84	84	85	86	87
10CHP-060		72	74	75	78	80	81	83	84	85	86	88	90
10CHP-024	LIQUID	182	198	216	233	240	249	265	280	297	314	331	348
10CHP-030		172	190	208	227	234	242	255	268	288	304	321	339
10CHP-036		189	205	221	238	244	253	269	283	304	325	346	367
10CHP-042		195	210	226	241	247	257	274	291	311	331	360	370
10CHP-048		183	211	231	239	244	252	265	287	302	324	345	361
10CHP-060		171	183	195	211	223	239	251	264	281	298	318	333

B-GCS/10CHA

For maximum performance of these cooling systems, the operating temperatures and pressure should be checked and superheat determined at Standard ARI test conditions of 82°F outdoor temperature - 80°F indoor dry bulb / 67°F indoor wet bulb. If superheat measured deviates from values in tables 12 or 13, refrigerant charge should be adjusted accordingly for maximum performance.

Verify system performance using table 14 or 15 as a general guide. Tables should not be used for charging unit. Minor variations in these pressures may be expected due to differences in installations. Significant differences could mean that the system is not properly charged or that a problem exists with some component in the system. Used carefully, this table could serve as a useful service guide. Data below is based on 80°F dry bulb / 67°F wet bulb return air. Allow unit operation to stabilize before taking pressure readings.

**TABLE 12
10GCS SUCTION SUPERHEAT TABLE**

UNIT MODEL NO.	SUCTION SUPERHEAT 82°F OD 80°F IDDB / 67°F IDWB
10GCS-024	18 - 20°
10GCS-030	17 - 19°
10GCS-036	17 - 19°
10GCS-042	18 - 20°
10GCS-048	16 - 18°
10GCS-060	16 - 18°

**TABLE 13
10CHA SUCTION SUPERHEAT TABLE**

UNIT MODEL NO.	SUCTION SUPERHEAT 82°F OD 80°F IDDB / 67°F IDWB
10CHA-024	18 - 20°
10CHA-030	17 - 19°
10CHA-036	17 - 19°
10CHA-042	18 - 20°
10CHA-048	16 - 18°
10CHA-060	16 - 18°

**TABLE 14
10GCS NORMAL OPERATING PRESSURES**

80°F db / 67°F wb RETURN AIR		AIR TEMPERATURE ENTERING OUTDOOR COIL (°F)											
MODEL	PRESSURE	65°	70°	75°	80°	82°	85°	90°	95°	100°	105°	110°	115°
10GCS-024	SUCTION	72	75	79	81	82	83	85	87	88	89	91	92
10GCS-030		67	70	73	75	77	78	81	83	84	84	85	85
10GCS-036		72	75	77	80	81	82	84	86	88	89	91	92
10GCS-042		72	75	78	82	83	84	86	88	89	90	92	93
10GCS-048		75	79	80	81	83	84	85	86	87	88	89	90
10GCS-060		79	79	80	81	81	82	83	84	85	86	87	88
10GCS-024	LIQUID	171	185	199	213	219	229	244	260	267	275	301	327
10GCS-030		186	192	198	215	221	231	247	263	282	300	312	323
10GCS-036		175	191	207	224	230	239	255	271	288	305	320	335
10GCS-042		181	197	213	229	235	245	261	277	294	310	328	345
10GCS-048		172	184	197	212	220	235	251	262	279	297	321	335
10GCS-060		192	205	222	236	249	263	277	293	313	331	348	360

**TABLE 15
10CHA NORMAL OPERATING PRESSURES**

80°F db / 67°F wb RETURN AIR		AIR TEMPERATURE ENTERING OUTDOOR COIL (°F)											
MODEL	PRESSURE	65°	70°	75°	80°	82°	85°	90°	95°	100°	105°	110°	115°
10CHA-024	SUCTION	72	75	79	81	82	83	85	87	88	89	91	92
10CHA-030		67	70	73	75	77	78	81	83	84	84	85	85
10CHA-036		72	75	77	80	81	82	84	86	88	89	91	92
10CHA-042		72	75	78	82	83	84	86	88	89	90	92	93
10CHA-048		77	79	80	81	83	84	85	86	87	88	89	90
10CHA-060		79	79	80	81	81	82	83	84	85	86	87	88
10CHA-024	LIQUID	171	185	199	213	219	229	244	260	267	275	301	327
10CHA-030		166	182	198	215	221	231	247	263	282	300	312	323
10CHA-036		175	191	207	224	230	239	255	271	288	305	320	335
10CHA-042		181	197	213	229	235	245	261	277	294	310	328	345
10CHA-048		172	184	197	212	220	235	251	262	279	297	321	335
10CHA-060		192	205	222	236	249	263	277	293	313	331	348	360

VII-Maintenance

Periodic inspection and maintenance normally consists of changing or cleaning filters and (under some conditions) cleaning the coils.

FILTERS

Not supplied. Inspect once a month. Replace disposable or clean permanent type as necessary. DO NOT replace permanent type with disposable.

MOTORS

Indoor and outdoor fan motors are permanently lubricated and require no maintenance.

OUTDOOR COIL

Dirt should not be allowed to accumulate on the outdoor coil surface or other parts in the air circuit. Cleaning should be as often as necessary to keep coil clean. Use a brush, vacuum cleaner attachment, or other suitable means. If water is used to clean coil, be sure power to the unit is shut off prior to cleaning.

NOTE - Care should be used when cleaning the coil so that the coil fins are not damaged.

TO CLEAN BURNERS (10GCS only)

Remove them from the furnace as explained in "Burner Instructions" in "GAS COMPONENTS" section. Vacuum and/or brush or brush as required.

VENT OUTLET

Visually inspect vent outlet periodically to make sure that

the buildup of soot and dirt is not excessive. If necessary, clean to maintain adequate opening to discharge flue products.

CLEANING FLUE PASSAGES & HEATING ELEMENTS

With proper combustion adjustment the heat exchanger will seldom need cleaning. If the heat exchanger should become sooted, it can be cleaned as follows:

- 1 - Remove the burner assembly as outlined in "BURNER INSTRUCTIONS" in "GAS COMPONENTS" section in this manual.
- 2 - Remove the combustion blower.
- 3 - At the bottom of the heat section, remove the screws securing the flue collector box. Carefully remove the flue collector box without ripping the adjacent insulation.
- 4 - Using a wire brush on a flexible wand, brush out the inside of each heat exchanger clam from the burner inlet and flue outlet ends.
- 5 - Brush out the inside of the flue collector box.
- 6 - If soot build-up is excessive, remove the vent motor and clean the wheel and housing. Run the wire brush down the flue extension at the outlet of the vent housing.
- 7 - After brushing is complete, blow all brushed areas with air. Vacuum as needed.
- 8 - Replace parts in the reverse order they were removed in steps 1 to 3.
- 9 - When replacing the flue collector box, be careful not to tear the adjoining insulation.
- 10 - Assure that all joints on the vent side of the combustion system are air tight. Apply a high temperature (+500°F) sealing compound where needed.

VIII-Wiring Diagram and Sequence of Operation

A-10GCS-024/060-1 MODELS

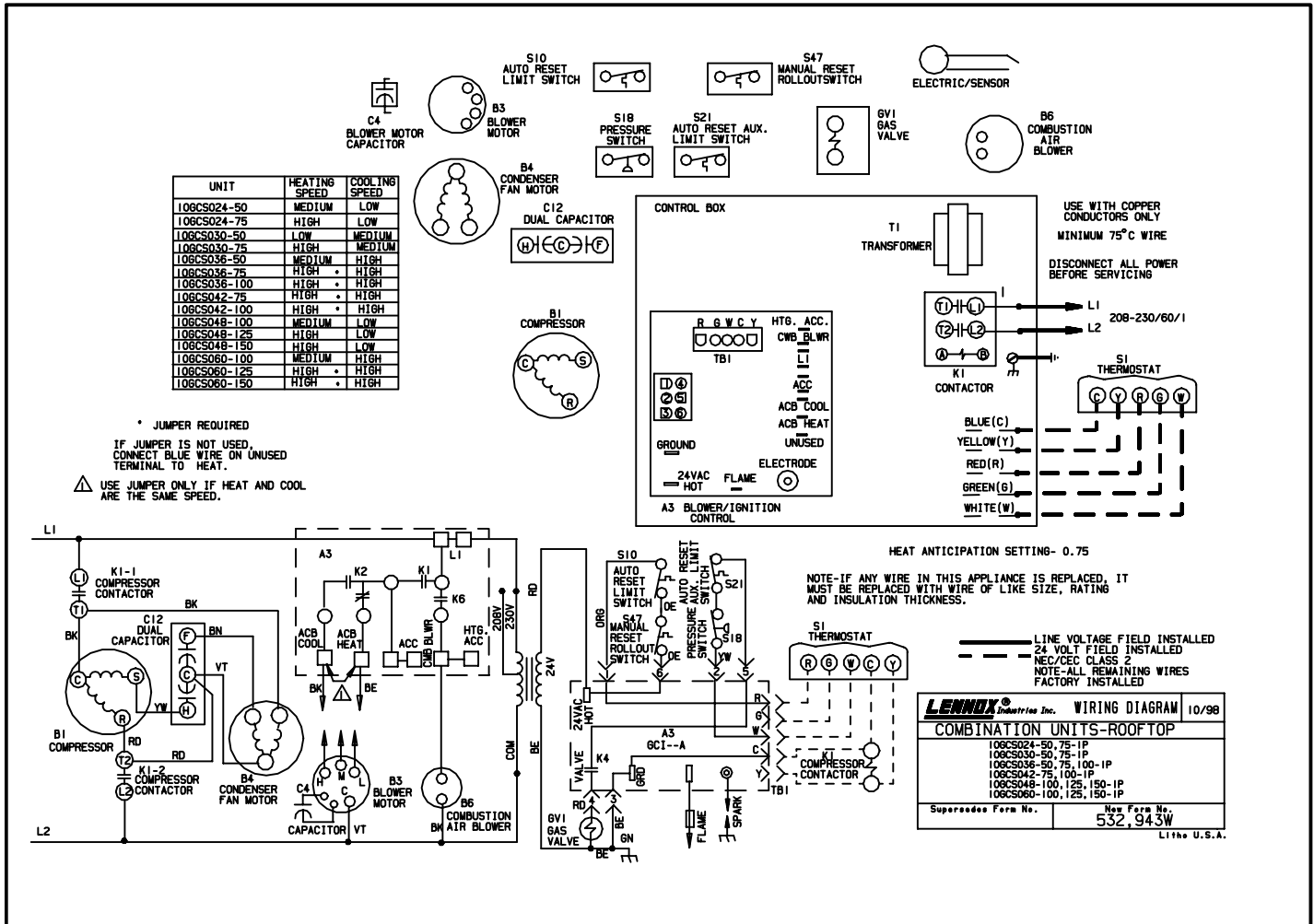

Cooling

- 1- Cooling demand initiates at Y1 in the indoor thermostat.
- 2- 24VAC from Y1 energizes time delay DL8, which energizes compressor contactor K1 if 5 minute delay has been satisfied. (DL8 is not shown and is an optional component. If unit is not equipped with DL8, 24VAC will go straight to K1.)
- 3- K1-1 and K1-2 close energizing compressor B1 and outdoor fan motor B4.
- 4- Compressor B1 and outdoor fan B4 begin immediate operation.
- 5- When cool demand is satisfied, "Y1" in the indoor thermostat de-energizes K1 contactor. K1-1 and K1-2 open de-energizing compressor B1 and outdoor fan B4.

Heating

- 1- Heating demand initiates at "W1" in the indoor thermostat.
- 2- A3 energizes the combustion air blower B6. When the N.O. combustion air prove switch closes, a prepurge period of 30 seconds will follow.
- 3- Assuming primary limit S10 and S47 rollout switch are closed, ignition control A3 will start ignition spark.
- 4- When flame is sensed, spark stops and main valve opens to light burners.
- 5- After 30 seconds blower control A3 energizes the main blower B3.
- 6- When heat demand is satisfied, "W1" in the indoor thermostat de-energizes control A3 which de-energizes the gas valve and combustion air blower B6. The main blower B3 runs for a designated period of 120 seconds.

B-10GCS-024/060-2 MODELS

UNIT	HEATING SPEED	COOLING SPEED
10GCS024-50	MEDIUM	LOW
10GCS024-75	HIGH	LOW
10GCS030-50	LOW	MEDIUM
10GCS030-75	HIGH	MEDIUM
10GCS036-50	MEDIUM	HIGH
10GCS036-75	HIGH	HIGH
10GCS036-100	HIGH	HIGH
10GCS042-75	HIGH	HIGH
10GCS042-100	HIGH	HIGH
10GCS048-100	MEDIUM	LOW
10GCS048-125	HIGH	LOW
10GCS048-150	HIGH	LOW
10GCS060-100	MEDIUM	HIGH
10GCS060-125	HIGH	HIGH
10GCS060-150	HIGH	HIGH

* JUMPER REQUIRED
 IF JUMPER IS NOT USED,
 CONNECT BLUE WIRE ON UNUSED
 TERMINAL TO HEAT.

△ USE JUMPER ONLY IF HEAT AND COOL
 ARE THE SAME SPEED.

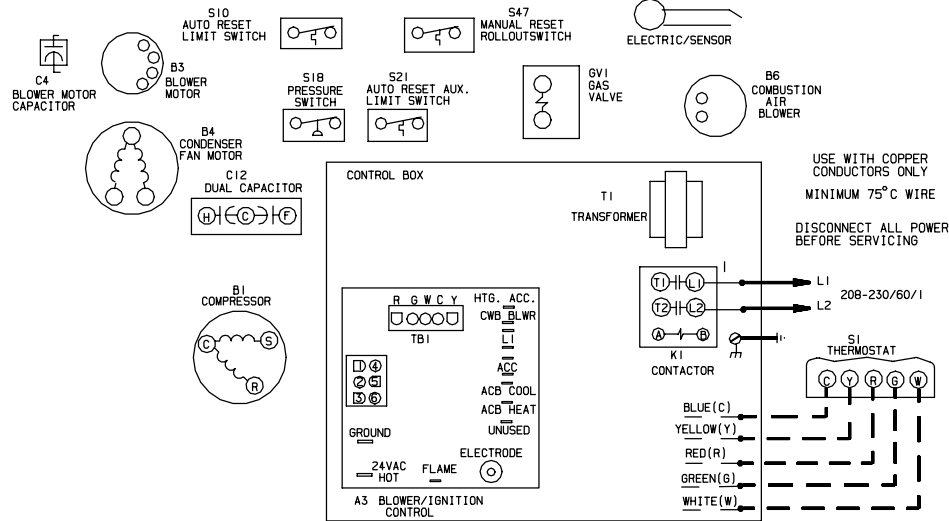

USE WITH COPPER
 CONDUCTORS ONLY
 MINIMUM 75°C WIRE

DISCONNECT ALL POWER
 BEFORE SERVICING

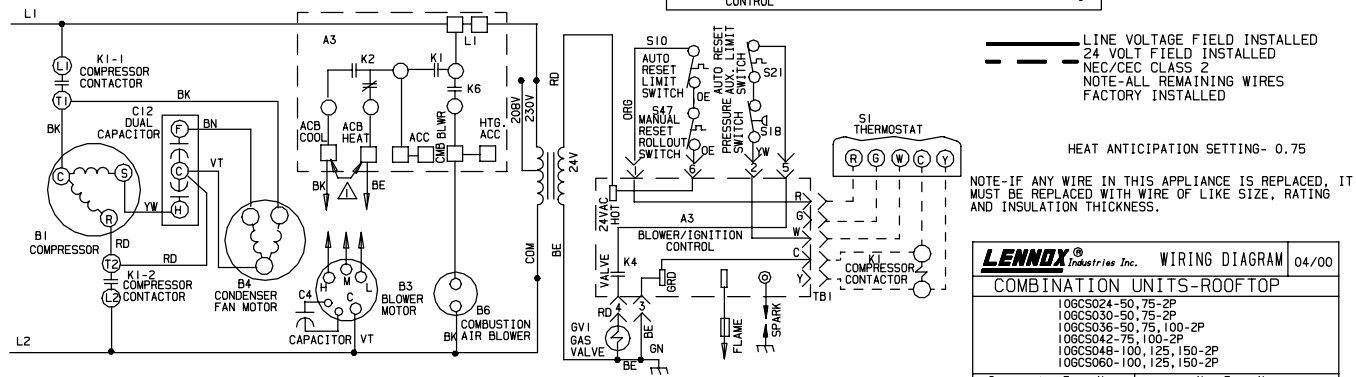

— LINE VOLTAGE FIELD INSTALLED
 --- 24 VOLT FIELD INSTALLED
 NEC/CEC CLASS 2
 NOTE-ALL REMAINING WIRES
 FACTORY INSTALLED

HEAT ANTICIPATION SETTING- 0.75

NOTE-IF ANY WIRE IN THIS APPLIANCE IS REPLACED, IT
 MUST BE REPLACED WITH WIRE OF LIKE SIZE, RATING
 AND INSULATION THICKNESS.

LENNOX Industries Inc. WIRING DIAGRAM		04/00
COMBINATION UNITS-ROOFTOP		
10GCS024-50, 75-2P 10GCS030-50, 75-2P 10GCS036-50, 75, 100-2P 10GCS042-75, 100-2P 10GCS048-100, 125, 150-2P 10GCS060-100, 125, 150-2P		
Supersedes Form No.	New Form No. 533,466W	

Litho U.S.A.

Cooling

- 1- Cooling demand initiates at Y1 in the indoor thermostat.
- 2- 24VAC from Y1 energizes time delay DL8, which energizes compressor contactor K1 if 5 minute delay has been satisfied. (DL8 is not shown and is an optional component. If unit is not equipped with DL8, 24VAC will go straight to K1.)
- 3- K1-1 and K1-2 close energizing compressor B1 and outdoor fan motor B4.
- 4- Compressor B1 and outdoor fan B4 begin immediate operation.
- 5- When cool demand is satisfied, "Y1" in the indoor thermostat de-energizes K1 contactor. K1-1 and K1-2 open de-energizing compressor B1 and outdoor fan B4.

Heating

- 1- Heating demand initiates at "W1" in the indoor thermostat.
- 2- A3 energizes the combustion air blower B6. When the N.O. combustion air prove switch closes, a prepurge period of 30 seconds will follow.
- 3- Assuming primary limit S10 and S47 rollout switch are closed, ignition control A3 will start ignition spark.
- 4- When flame is sensed, spark stops and main valve opens to light burners.
- 5- After 30 seconds blower control A3 energizes the main blower B3.
- 6- When heat demand is satisfied, "W1" in the indoor thermostat de-energizes control A3 which de-energizes the gas valve and combustion air blower B6. The main blower B3 runs for a designated period of 120 seconds.

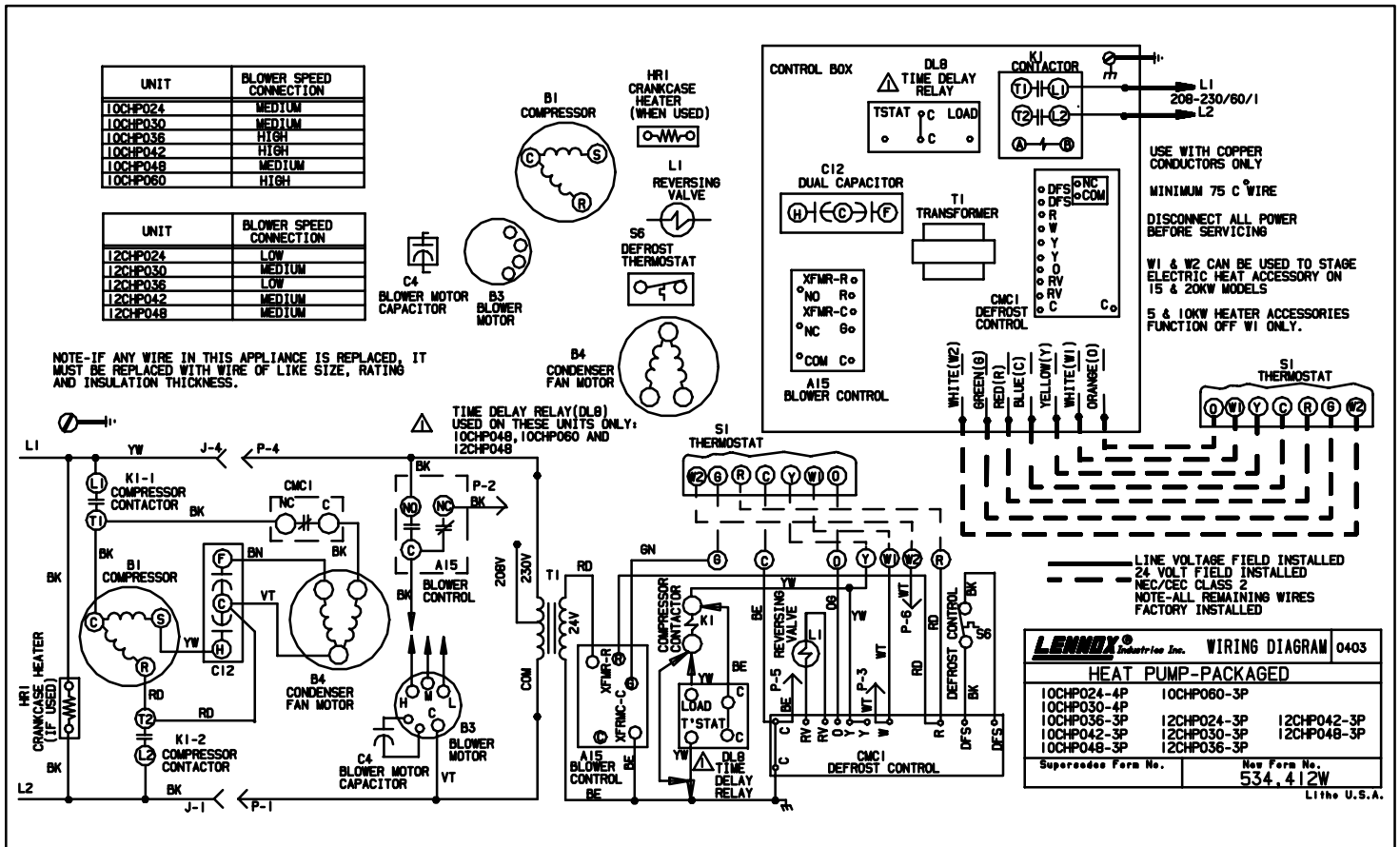

Cooling

- Internal thermostat wiring energizes terminal "O" by cooling mode selection, energizing reversing valve L1.
- Cooling demand initiates at Y1 in the indoor thermostat.
- 24VAC from Y1 energizes compressor contactor K1. (10CHP048/060, Y1 energizes time delay DL8, which energizes compressor contactor K1 if 5 minute delay has been satisfied).
- K1-1 and K1-2 close energizing compressor B1 and outdoor fan motor B4.
- Compressor B1 and outdoor fan B4 begin immediate operation.
- Main blower B3 begins operation.
- When cool demand is satisfied, "Y1" in the indoor thermostat de-energizes K1 contactor. K1-1 and K1-2 open de-energizing compressor B1 and outdoor fan B4.
- Main blower B3 is de-energized following 90 second delay.
- Terminal "O" is de-energized when internal thermostat is out of cool mode, de-energizing reversing valve L1.

First Stage Heat

- Heating demand initiates at "Y1" in the thermostat.
- 24VAC energizes compressor contactor K1. (10CHP048/060, Y1 energizes time delay DL8, which energizes compressor contactor K1 if 5 minute delay has been satisfied).
- K1-1 and K1-2 close, energizing compressor B1 and outdoor fan B4.
- Compressor B1 and outdoor fan B4 begin operation.
- Main blower B3 begins operation.

Defrost Mode

- During heating operation when outdoor coil temperature drops below 32°F (0°C) defrost switch S6 closes.
- Defrost control CMC1 begins timing. If defrost thermostat S6 remains closed at the end of 30, 60 or 90 minute period, defrost control energizes and defrost begins
- During defrost CMC1 energizes the reversing valve L1 and de-energizes the outdoor fan B4.
- Defrost continues 10 minutes or until defrost thermostat switch S6 opens. When defrost thermostat switch opens, defrost control CMC1 loses power and resets.
- When CMC1 resets, reversing valve L1 is de-energized while outdoor fan B4 is energized.

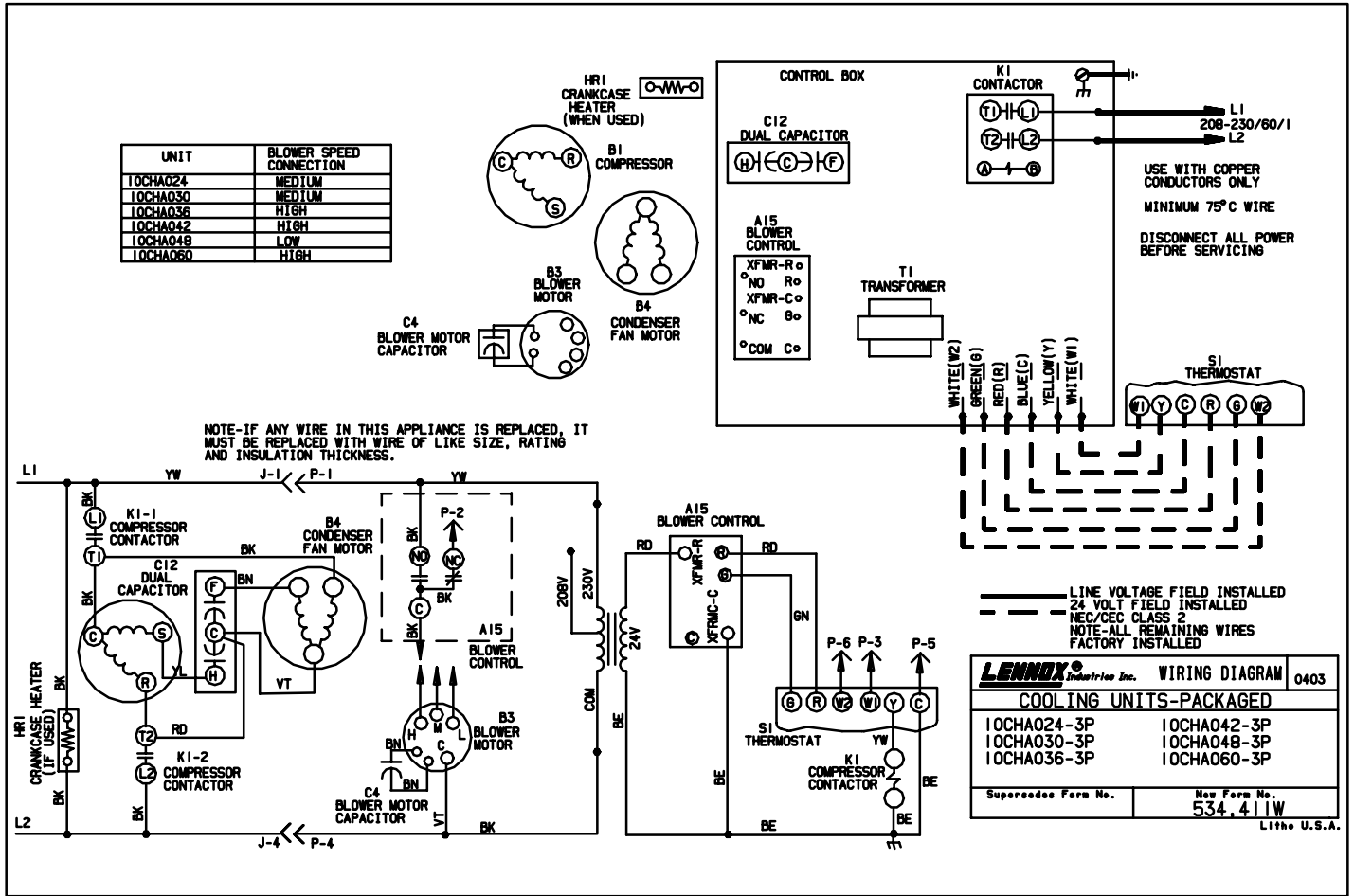

Cooling

- 1- Cooling demand initiates at Y1 in the indoor thermostat.
- 2- 24VAC from Y1 energizes time delay DL8, which energizes compressor contactor K1 if 5 minute delay has been satisfied. (DL8 is not shown and is an optional component. If unit is not equipped with DL8, 24VAC will go straight to K1.)
- 3- K1-1 and K1-2 close energizing compressor B1 and outdoor fan motor B4.

- 4- Compressor B1 and outdoor fan B4 begin immediate operation.
- 5- Main blower B3 is energized.
- 6- When cool demand is satisfied, "Y1" in the indoor thermostat de-energizes K1 contactor. K1-1 and K1-2 open de-energizing compressor B1 and outdoor fan B4.
- 7- Main blower B3 is de-energized following 90 second delay.

Heating

See electric heat sequence of operation.

E-ECH29-1-P (ECH29-25 Shown)

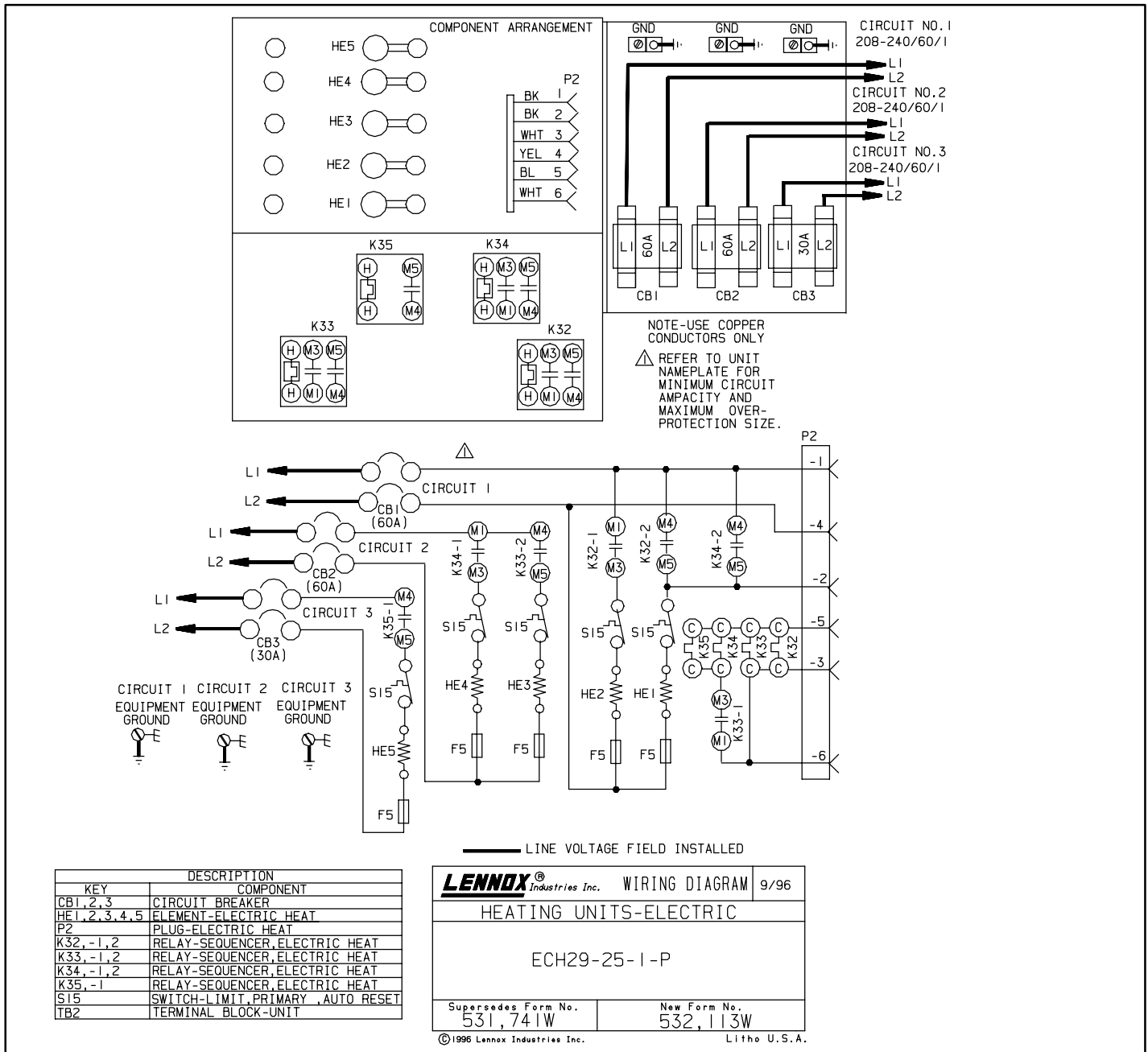

First Stage Heat

1. When there is a call for heat, W1 energizes electric heat relays K32 and K33.
2. When K32-1 closes, electric heat element HE2 is energized assuming the N.C. primary limit S15 is closed. K32-2 closes energizing blower B3 and heating element HE1.
3. When K33-2 closes, heating element HE3 is energized assuming primary limit S15 is closed.

Second Stage Heat

4. K33-1 closes energizing K34 and K35.
5. When K34-1 closes, heating element HE4 is energized assuming primary limit S15 is closed.
6. When K34-2 closes, the blower will energize (if it has not energized before).
7. When K35-1 closes, heating element HE5 is energized assuming primary limit S15 is closed.