



©2011 Lennox Industries Inc.
Dallas, Texas, USA



These instructions are intended as a general guide and do not supersede local codes in any way. Consult authorities having jurisdiction before installation.

RETAIN THESE INSTRUCTIONS FOR FUTURE REFERENCE

NOTICE TO INSTALLER

UNIT PLACEMENT

It is critical for proper unit operation to place outdoor unit on an elevated surface as described in *Unit Placement* section on page 6.

BRAZING LINE SET TO SERVICE VALVES

It is imperative to follow the brazing technique illustrated starting on page 11 to avoid damaging the service valve's internal seals.

CAUTION

Physical contact with metal edges and corners while applying excessive force or rapid motion can result in personal injury. Be aware of, and use caution when working near these areas during installation or while servicing this equipment.

WARNING

Improper installation, adjustment, alteration, service or maintenance can cause personal injury, loss of life, or damage to property.

Installation and service must be performed by a licensed professional installer (or equivalent) or a service agency.

IMPORTANT

The Clean Air Act of 1990 bans the intentional venting of refrigerant (CFCs, HCFCs and HFCs) as of July 1, 1992. Approved methods of recovery, recycling or reclaiming must be followed. Fines and/or incarceration may be levied for noncompliance.

IMPORTANT

This unit must be matched with an indoor coil as specified in Lennox Engineering Handbook. Coils previously charged with HCFC-22 must be flushed.

INSTALLATION INSTRUCTIONS

Merit® Series 13HPX Units

HEAT PUMP UNITS

506727-01

06/11

Supersedes 04/11



TABLE OF CONTENTS

Shipping and Packing List 1

General 1

Model Number Identification 2

Unit Dimensions 3

Typical Parts Arrangement 3

Caps and Fasteners Torque Requirements 3

Operating Gauge Set and Service Valves 3

Recovering Refrigerant from Existing System 5

New Outdoor Unit Placement 6

Removing and Installing Panels 8

Line Set Requirements 9

Brazing Connections 11

Indoor Refrigerant Metering Device Removal and Flushing Line Set and Indoor Coil 14

Installing New Indoor Metering Device 15

Leak Test Line Set and Indoor Coil 16

Evacuating Line Set and Indoor Coil 17

Electrical Connections 18

Unit Start-Up 23

Servicing and Weighing In Refrigerant for Units Delivered Void of Charge 23

Optimizing System Refrigerant Charge 25

System Operation 29

Defrost System 29

Maintenance (Dealer and Homeowner) 30

Start-Up and Performance Checklist 32

Shipping and Packing List

Check the unit components for shipping damage. If you find any damage, immediately contact the last carrier.

1 — Assembled outdoor unit

General

The 13HPX outdoor unit uses HFC-410A refrigerant. This unit must be installed with a matching indoor blower coil and line set as outlined in the 13HPX Engineering Handbook. These outdoor units are designed for use in check / expansion valve (CTXV) systems only and are not to be used with other refrigerant flow control devices. An indoor coil check / expansion valve approved for use with HFC-410A must be ordered separately and installed prior to operating the unit.



Model Number Identification

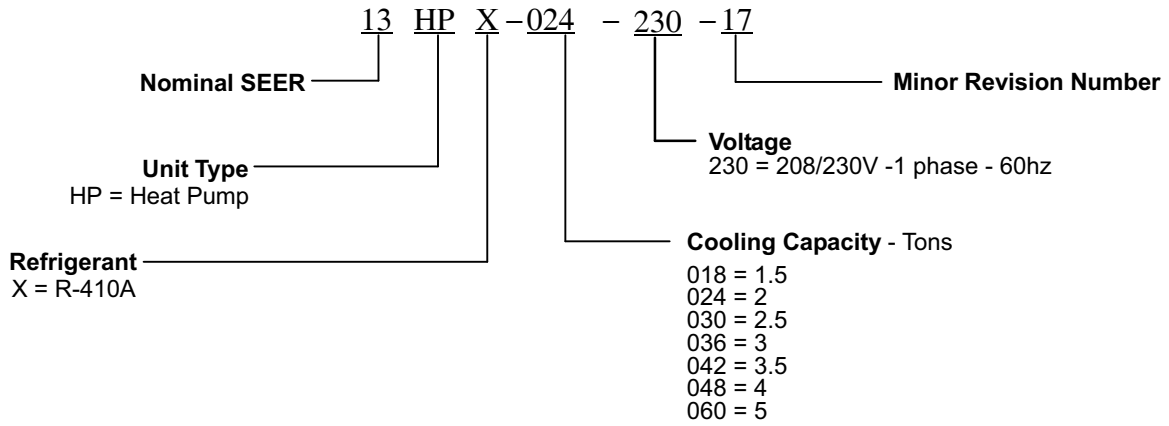

Unit Dimensions - inches (mm)

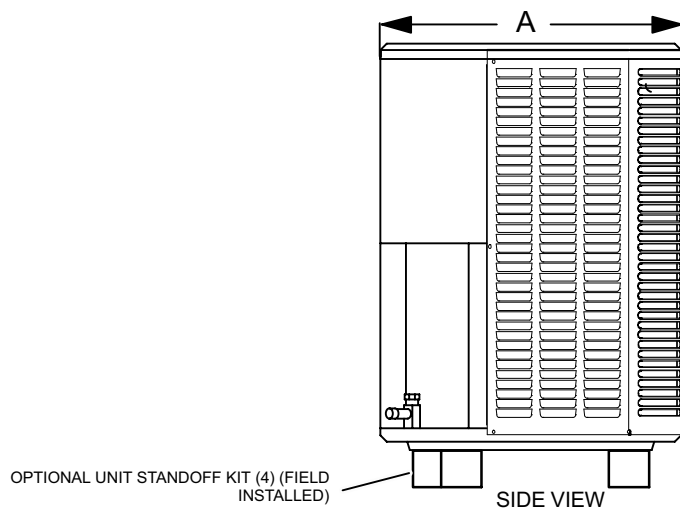
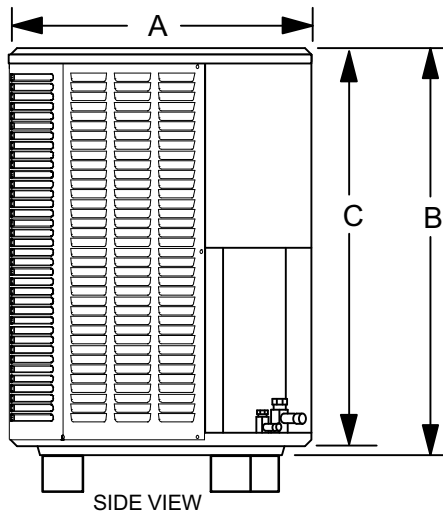

Model No.	A	B	C
13HPX-018-230	24-1/4 (616)	33-1/4 (845)	32-1/2 (826)
13HPX-024-230	24-1/4 (616)	33-1/4 (845)	32-1/2 (826)
13HPX-030-230	28-1/4 (718)	29-1/4 (743)	28-1/2 (724)
13HPX-036-230	28-1/4 (718)	37-1/4 (946)	36-1/2 (927)
13HPX-042-230	28-1/4 (718)	43-1/4 (1099)	42-1/4 (1073)
13HPX-048-230	28-1/4 (718)	33-1/4 (845)	32-1/2 (826)
13HPX-060-230	28-1/4 (718)	37-1/4 (946)	36-1/2 (927)

Typical Unit Parts Arrangement

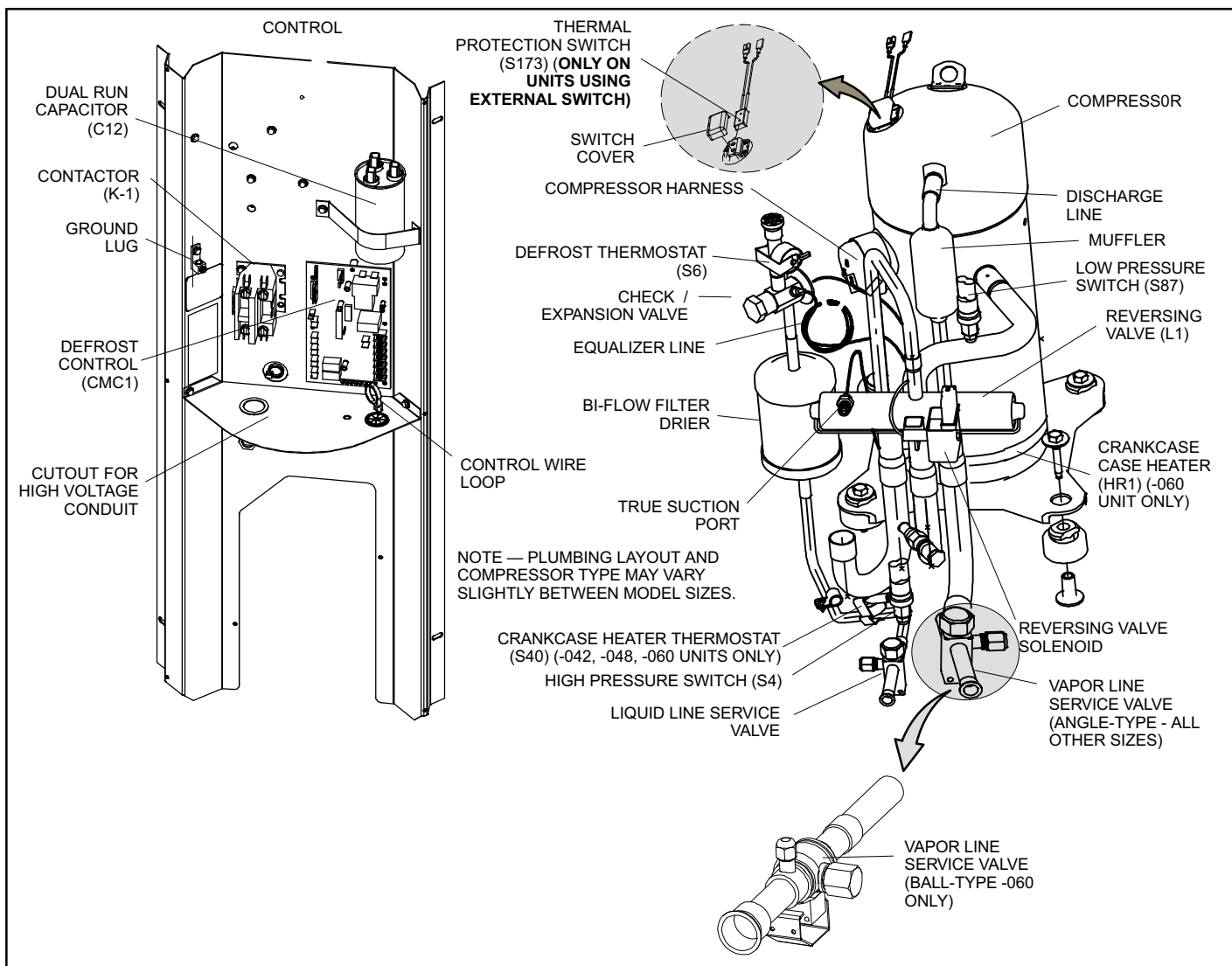

Figure 1. Typical Unit Parts Arrangement

Caps and Fasteners Torque Requirements

! IMPORTANT

Only use Allen wrenches of sufficient hardness (50Rc - Rockwell Harness Scale minimum). Fully insert the wrench into the valve stem recess.

Service valve stems are factory-torqued (from 9 ft.-lbs for small valves, to 25 ft.-lbs for large valves) to prevent refrigerant loss during shipping and handling. Using an Allen wrench rated at less than 50Rc risks rounding or breaking off the wrench, or stripping the valve stem recess.

See the Lennox Service and Application Notes #C-08-1 for further details and information.

When servicing or repairing HVAC components, ensure the fasteners are appropriately tightened. Table 1 provides torque values for fasteners.

Table 1. Torque Requirements

Parts	Recommended Torque	
Service valve cap	8 ft.- lb.	11 NM
Sheet metal screws	16 in.- lb.	2 NM
Machine screws #10	28 in.- lb.	3 NM
Compressor bolts	90 in.- lb.	10 NM
Gauge port seal cap	8 ft.- lb.	11 NM

Operating Gauge Set and Service Valves

⚠ IMPORTANT

To prevent stripping of the various caps used, the appropriately sized wrench should be used and fitted snugly over the cap before tightening.

OPERATING SERVICE VALVES

The liquid and vapor line service valves are used for refrigerant recovery, flushing, leak testing, evacuating, weighing in refrigerant and optimizing system charge.

Each valve is equipped with a service port which has a factory-installed valve core. Figure 2 provides information on how to access and operate both angle- and ball-type service valves.

USING MANIFOLD GAUGE SET

When checking the system charge, only use a manifold gauge set that features low-loss anti-blow back fittings.

Manifold gauge set used for HFC-410A refrigerant systems must be capable of handling the higher system operating pressures. The manifold gauges should be rated for:

- High side — Pressure range of 0 - 800 pound-force per square inch gauge (psig)
- Low side — Use with 30" vacuum to 250 psig with dampened speed to 500 psig
- Manifold gauge set hoses must be rated for use to 800 psig of pressure with a 4000 psig burst rating.

Operating Angle-Type Service Valve:

1. Remove stem cap with an appropriately sized wrench.
2. Use a service wrench with a hex-head extension (3/16" for liquid line valve sizes and 5/16" for vapor line valve sizes) to back the stem out counterclockwise as far as it will go to open the service valve.

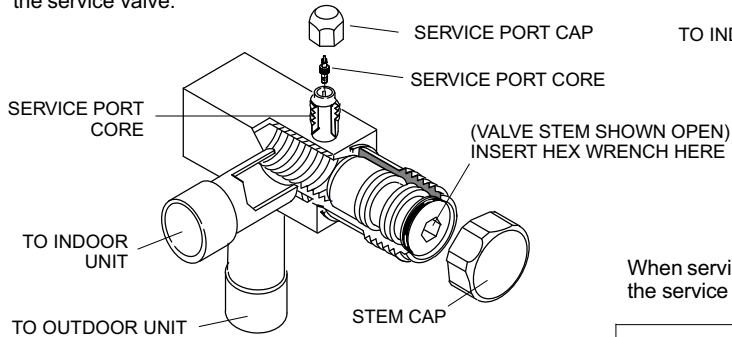

When service valve is **OPEN**, the service port is open to line set, indoor and outdoor unit.

Operating Ball-Type Service Valve:

1. Remove stem cap with an appropriately sized wrench.
2. Use an appropriately sized wrench to open.

A To **open** rotate stem counterclockwise 90°.

B To **close** rotate stem clockwise 90°.

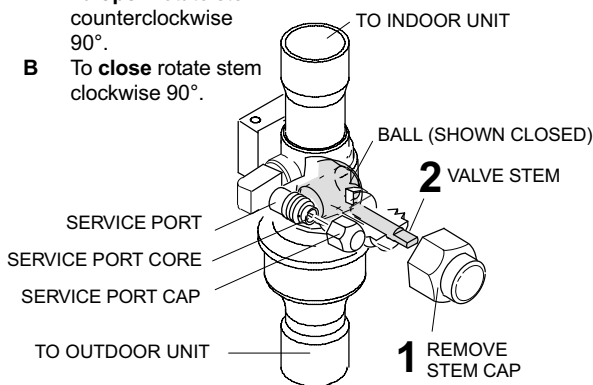

NOTE — A label with specific torque requirements may be affixed to the stem cap. If the label is present, use the specified torque.

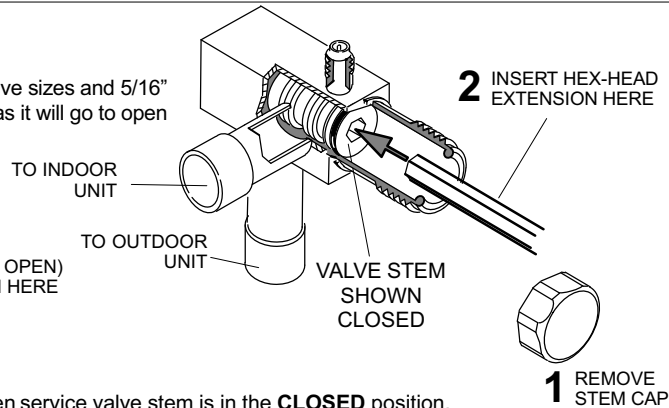

When service valve stem is in the **CLOSED** position, the service port is open to the line set and indoor unit.

To Access Service Port:

A service port cap protects the service port core from contamination and serves as the primary leak seal.

1. Remove service port cap with an appropriately sized wrench.
2. Connect gauge set to service port.
3. When testing is completed, replace service port cap and tighten as follows:
 - With torque wrench: Finger tighten and torque cap per table 1.
 - Without torque wrench: Finger tighten and use an appropriately sized wrench to turn an additional 1/6 turn clockwise.

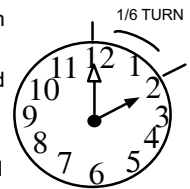

Reinstall Stem Cap:

Stem cap protects the valve stem from damage and serves as the primary seal. Replace the stem cap and tighten as follows:

- With Torque Wrench: Finger tighten and then torque cap per table 1.
- Without Torque Wrench: Finger tighten and use an appropriately sized wrench to turn an additional 1/12 turn clockwise.

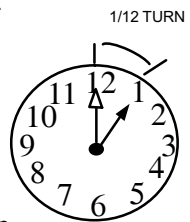
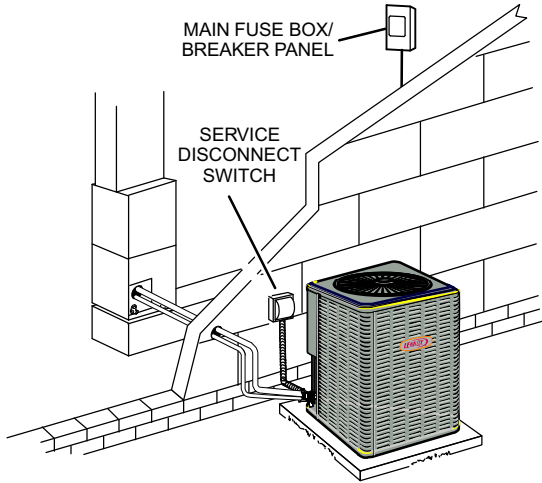

Figure 2. Angle and Ball Service Valves

Recovering Refrigerant from Existing System

1 DISCONNECT POWER

Disconnect all power to the existing outdoor unit at the disconnect switch and/or main fuse box/breaker panel.



2 CONNECT MANIFOLD GAUGE SET

Connect a manifold gauge set, clean recovery cylinder and a recovery machine to the service ports of the existing unit.

NOTE — Use the recovery machine instructions to make the correct manifold gauge set connections for recovery refrigerant. The illustration below is a typical connection.

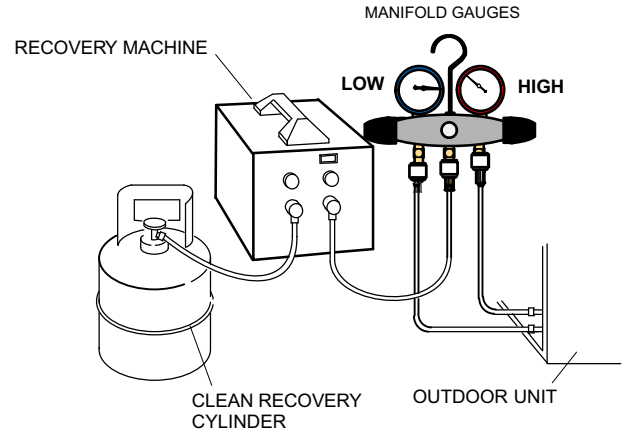

3 RECOVERING REFRIGERANT

Remove existing refrigerant using one of the following procedures:

METHOD 1:

Use **Method 1** if the existing outdoor unit is **not** equipped with shut-off valves, or if the unit is **not** operational and you plan to **use the existing** to flush the system. Recover all refrigerant from the existing system using a recovery machine and clean recovery cylinder. Check gauges after shutdown to confirm that the entire system is completely void of refrigerant.

METHOD 2:

Use **Method 2** if the existing outdoor unit is equipped with manual shut-off valves, and you plan to **use new refrigerant** to flush the system.

Perform the following task:

- A Start the existing system in the cooling mode and close the liquid line valve.
- B Use the compressor to pump as much of the existing HCFC-22 refrigerant into the outdoor unit until the outdoor system is full. Turn the outdoor unit main power OFF and use a recovery machine to remove the remaining refrigerant from the system.

NOTE — It may be necessary to bypass the low pressure switches (if equipped) to ensure complete refrigerant evacuation.

- C When the low side system pressures reach 0 psig, close the vapor line valve.
- D Check gauges after shutdown to confirm that the valves are not allowing refrigerant to flow back into the low side of the system.

METHOD 2 LIMITATIONS

NOTE — When using **Method 2**, the listed devices below **could prevent** full system charge recovery into the outdoor unit:

- Outdoor unit's high or low-pressure switches (if applicable) when tripped can cycle the compressor OFF.
- Compressor can stop pumping due to tripped internal pressure relief valve.
- Compressor has internal vacuum protection that is designed to unload the scrolls (compressor stops pumping) when the pressure ratio meets a certain value or when the suction pressure is as high as 20 psig. (**Compressor suction pressures should never be allowed to go into a vacuum. Prolonged operation at low suction pressures will result in overheating of the scrolls and permanent damage to the scroll tips, drive bearings and internal seals.**)

Once the compressor can not pump down to a lower pressure due to any of the above mentioned system conditions, shut off the vapor valve. Turn OFF the main power to unit and use a recovery machine to recover any refrigerant left in the indoor coil and line set.

Figure 3. Refrigerant Recovery

⚠ IMPORTANT

The Environmental Protection Agency (EPA) prohibits the intentional venting of HFC refrigerants during maintenance, service, repair and disposal of appliance. Approved methods of recovery, recycling or reclaiming must be followed.

⚠ WARNING

Refrigerant can be harmful if it is inhaled. Refrigerant must be used and recovered responsibly. Failure to follow this warning may result in personal injury or death.

New Outdoor Unit Placement

CAUTION

In order to avoid injury, take proper precaution when lifting heavy objects.

Remove existing outdoor unit prior to placement of new outdoor unit. See *Unit Dimensions* on page 2 for sizing mounting slab, platforms or supports. Refer to figure 4 for mandatory installation clearance requirements.

POSITIONING CONSIDERATIONS

Consider the following when positioning the unit:

- Some localities are adopting sound ordinances based on the unit's sound level registered from the adjacent property, not from the installation property. Install the unit as far as possible from the property line.
- When possible, do not install the unit directly outside a window. Glass has a very high level of sound

transmission. For proper placement of unit in relation to a window see the provided illustration in figure 5, detail A.

PLACING UNIT ON SLAB

When installing unit at grade level, the top of the slab should be high enough above grade so that water from higher ground will not collect around the unit. The slab should have a slope tolerance as described in figure 5, detail B.

ROOF MOUNTING

Install the unit a minimum of 4 inches (102 mm) above the roof surface to avoid ice build-up around the unit. Locate the unit above a load bearing wall or area of the roof that can adequately support the unit. Consult local codes for rooftop applications. See figure 5, detail C for other roof top mounting considerations.

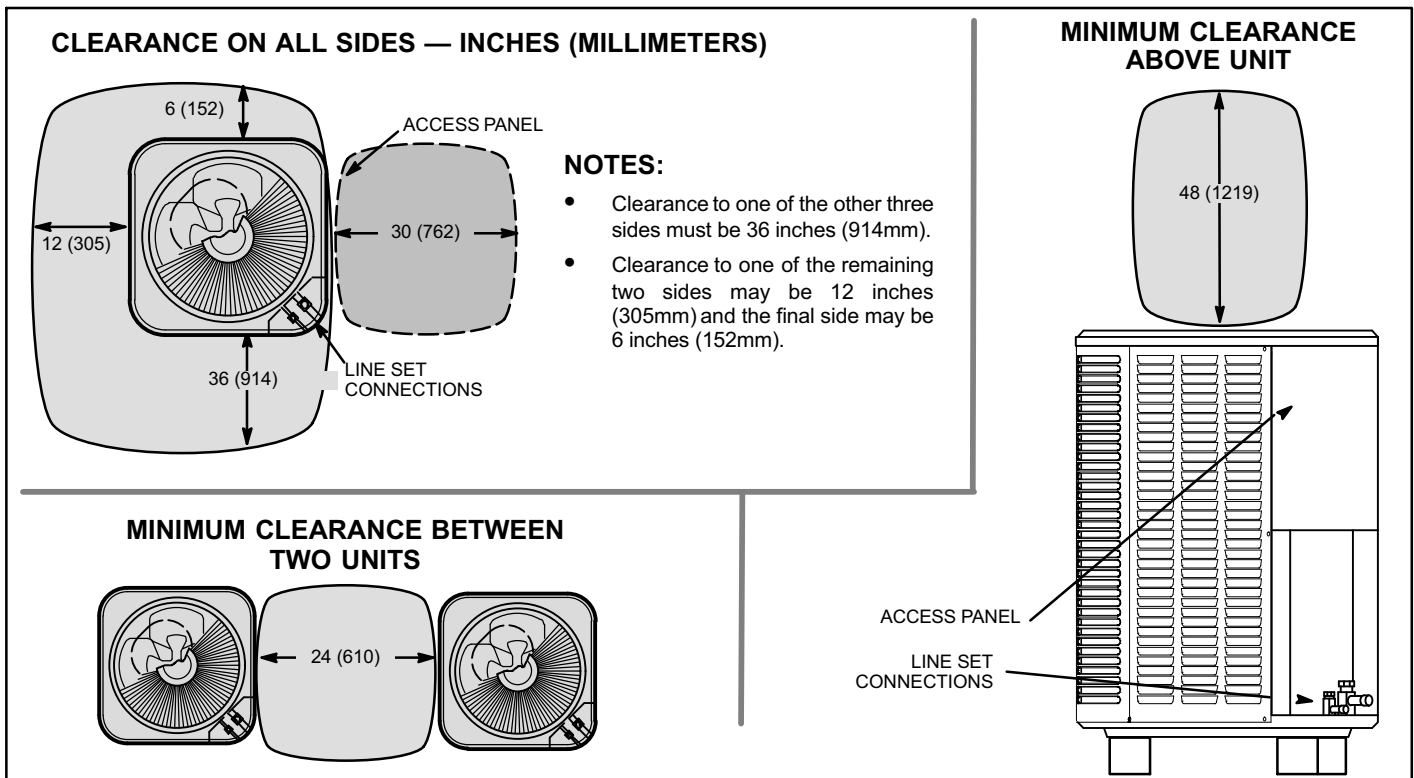

Figure 4. Installation Clearances

NOTICE

Roof Damage!

This system contains both refrigerant and oil. Some rubber roofing material may absorb oil and cause the rubber to swell when it comes into contact with oil. The rubber will then bubble and could cause leaks. Protect the roof surface to avoid exposure to refrigerant and oil during service and installation. Failure to follow this notice could result in damage to roof surface.

DETAIL A

INSTALL UNIT AWAY FROM WINDOWS

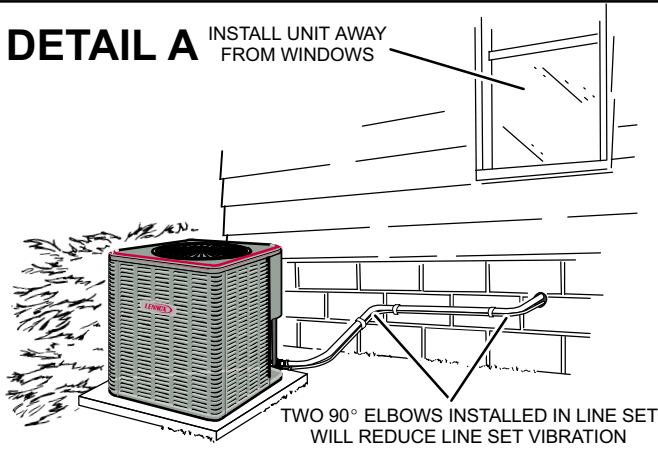

DETAIL C

If unit coil cannot be mounted away from prevailing winter winds, a wind barrier should be constructed. Size barrier at least the same height and width as outdoor unit. Mount barrier 24 inches (610 mm) from the sides of the unit in the direction of prevailing winds as illustrated.

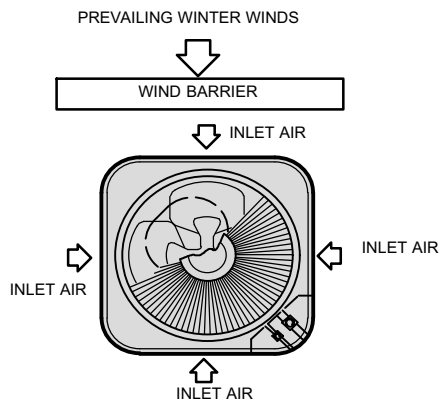

DETAIL B

These units operate under a wide range of weather conditions; therefore, several factors must be considered when positioning the outdoor unit. The unit must be positioned to give adequate clearances for sufficient airflow and servicing.

- Install unit level or, if on a slope, maintain slope tolerance of 2 degrees (or 2 inches per 5 feet [50 mm per 1.5 m]) away from building structure.
- Install the unit high enough above the ground or roof to allow adequate drainage of defrost water and prevent ice or snow build-up.
- In heavy snow areas, do not locate the unit where drifting will occur. The unit base should be elevated above the depth of average snows. Stand-off kits are available for ordering using either catalog numbers — 94J45 (4 each) or 30K79 (20 each).
- When installed in areas where low ambient temperatures exist, locate unit so winter prevailing winds do not blow directly onto outdoor unit.
- Locate unit away from overhanging roof lines which would allow water or ice to drop on, or in front of, coil or onto unit.

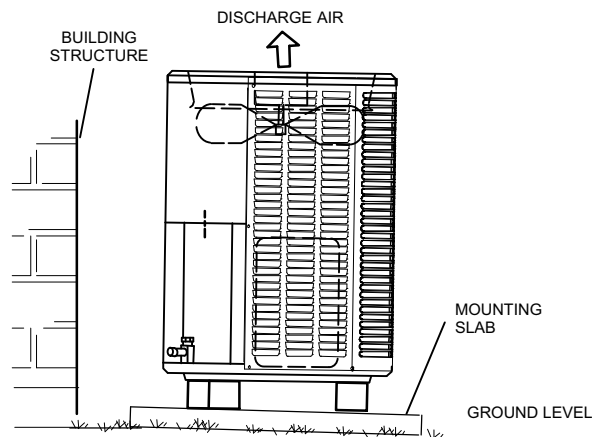

Figure 5. Placement, Slab Mounting and Wind Barrier

Removing and Installing Louvers

⚠ WARNING

To prevent personal injury, or damage to panels, unit or structure, be sure to observe the following:

While installing or servicing this unit, carefully stow all removed panels out of the way, so that the panels will not cause injury to personnel, nor cause damage to objects or structures nearby, nor will the panels be subjected to damage (e.g., being bent or scratched).

While handling or stowing the panels, consider any weather conditions, especially windy conditions, that may cause panels to be blown around and battered.

When removing the unit panels. Remove panel **A** first, then **B**, **C** and finally **D**.
When reinstalling panels, reverse that order starting with panel **D**, **C**, **B** and finally **A**.

REMOVAL

STEP 1

TO REMOVE PANEL, REMOVE MOUNTING SCREWS SECURING PANEL TO THE UNIT.

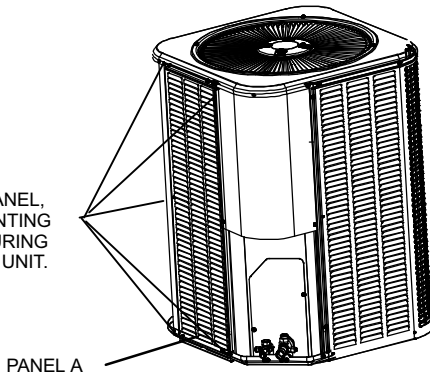

STEP 2

SLIGHTLY LIFT PANEL **A** IN ORDER TO CLEAR SIDE LIPS OF PANEL FROM BASE OF UNIT.

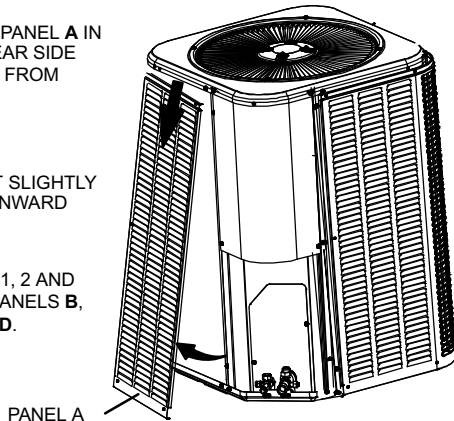

STEP 3

TILT PANEL OUT SLIGHTLY AND PULL DOWNWARD TO REMOVE.

REPEAT STEPS 1, 2 AND 3 TO REMOVE PANELS **B**, **C** AND FINALLY **D**.

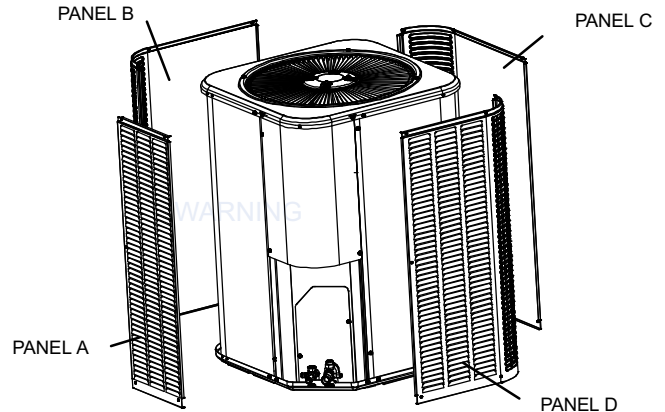

INSTALLATION

STEP 1

STARTING WITH PANEL **D**, INSERT PANEL UNDER UNIT TOP CAP LIP AND LIFT SLIGHTLY TO CLEAR SIDE LIP OF PANEL FROM BASE.

STEP 2

MOVE PANEL IN TOWARDS UNIT. ALIGN LEFT/RIGHT SIDE LIPS OF PANEL WITH GROOVE INSERTS ALONG LEFT/RIGHT SIDE OF UNIT.

STEP 3

SECURE PANEL, WITH MOUNTING SCREWS.

REPEAT STEPS 1 AND 2 TO INSTALL PANELS **C**, **B** AND FINALLY **A**.

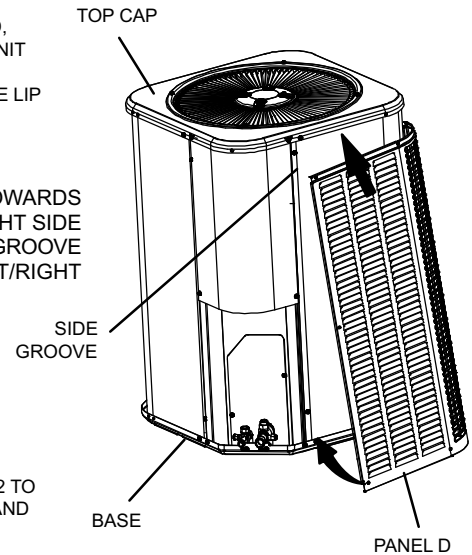

Figure 6. Louvers

Line Set Requirements

This section provides information on: installation of new or replacement line set.

- Adding Polyol ester oil requirements
- New or replacement line set installation
- Using existing line set.

ADDING POLYOL ESTER OIL REQUIREMENTS

⚠ IMPORTANT

Mineral oils are not compatible with HFC-410A. If oil must be added, it must be a Polyol Ester oil.

The compressor is charged with sufficient Polyol Ester oil (POE) for line set lengths up to 50 feet. Recommend adding oil to system based on the amount of refrigerant charge in the system. Systems with 20 pounds or less of refrigerant required no oil to be added.

For systems over 20 pounds - add one ounce for every five (5) pounds of HFC-410A refrigerant.

Recommended topping-off POE oils are Mobil EAL ARCTIC 22 CC or ICI EMKARATE™ RL32CF.

NEW OR REPLACEMENT LINE SET INSTALLATION

Field refrigerant piping consists of both liquid and vapor lines from the outdoor unit to the indoor coil. Use Lennox L15 (sweat, non-flare) series line set, or field-fabricated refrigerant line sizes as specified in table 2.

If refrigerant lines are routed through a wall, then seal and isolate the opening so vibration is not transmitted to the building. Pay close attention to line set isolation during installation of any HVAC system. When properly isolated from building structures (walls, ceilings, floors), the refrigerant lines will not create unnecessary vibration and subsequent sounds. See figure 7 for recommended installation practices.

NOTE — When installing refrigerant lines longer than 50 feet, see the Lennox Refrigerant Piping Design and Fabrication Guidelines, CORP. 9351-L9, or contact Lennox Technical Support Product Applications for assistance. To obtain the correct information from Lennox, be sure to communicate the following information:

- Model (13HPX) and size of unit (e.g. -036).
- Line set diameters for the unit being installed as listed in table 2 and total length of installation.
- Number of elbows vertical rise or drop in the piping.

USING EXISTING LINE SET

Things to consider:

- Liquid line that meter the refrigerant, such as RFC1 liquid line, **must not** be used in this application.
- Existing line set of proper size as listed in table 2 may be reused.
- If system was previously charged with HCFC-22 refrigerant, then existing line set must be flushed (see *Flushing Line Set and Indoor Coil* on page 14).

If existing line set is being used, then proceed to *Brazing Connections* on page 11.

⚠ IMPORTANT

Lennox highly recommends changing line set when converting the existing system from HCFC-22 to HFC-410A. If that is not possible and the line set is the proper size as reference in table 2, use the procedure outlined under *Flushing Line Set and Indoor Coil* on page 13.

⚠ IMPORTANT

If this unit is being matched with an approved line set or indoor unit coil which was previously charged with mineral oil, or if it is being matched with a coil which was manufactured before January of 1999, the coil and line set must be flushed prior to installation. Take care to empty all existing traps. Polyol ester (POE) oils are used in Lennox units charged with HFC-410A refrigerant. Residual mineral oil can act as an insulator, preventing proper heat transfer. It can also clog the expansion device, and reduce the system performance and capacity. Failure to properly flush the system per the instructions below will void the warranty.

Table 2. Refrigerant Line Set — Inches (mm)

Model	Field Connections		Recommended Line Set		
	Liquid Line	Vapor Line	Liquid Line	Vapor Line	L15 Line Sets
13HPX-018-230	3/8 in. (10 mm)	3/4 in. (19 mm)	3/8 in. (10 mm)	3/4 in. (19 mm)	L15-41 — 15 ft. - 50 ft. (4.6 m - 15 m)
13HPX-024-230					
13HPX-030-230					
13HPX-036-230					
13HPX-042-230	3/8 in. (10 mm)	7/8 in. (22 mm)	3/8 in. (10 mm)	7/8 in. (22 mm)	L15-65 — 15 ft. - 50 ft. (4.6 m - 15 m)
13HPX-048-230					
13HPX-060-230	3/8 in. (10 mm)	1-1/8 in. (29 mm)	3/8 in. (10 mm)	1-1/8 in. (29 mm)	Field Fabricated

NOTE — Some applications may require a field provided 7/8" to 1-1/8" adapter

Line Set Isolation — The following illustrations are examples of proper refrigerant line set isolation:

REFRIGERANT LINE SET — TRANSITION FROM VERTICAL TO HORIZONTAL

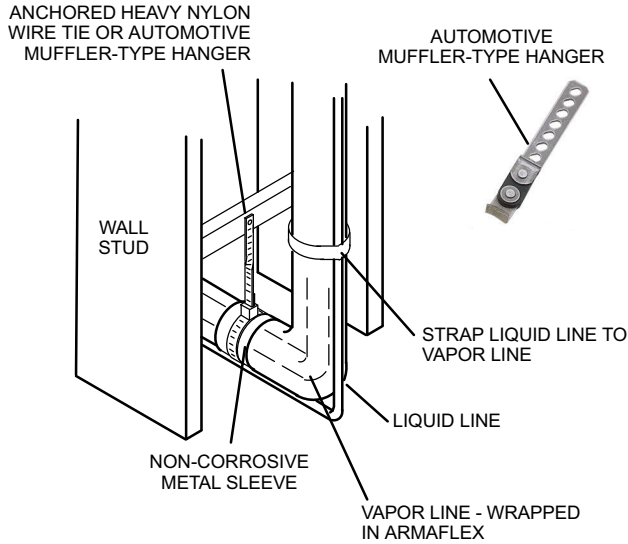

REFRIGERANT LINE SET — INSTALLING VERTICAL RUNS (NEW CONSTRUCTION SHOWN)

NOTE — Insulate liquid line when it is routed through areas where the surrounding ambient temperature could become higher than the temperature of the liquid line or when pressure drop is equal to or greater than 20 psig.

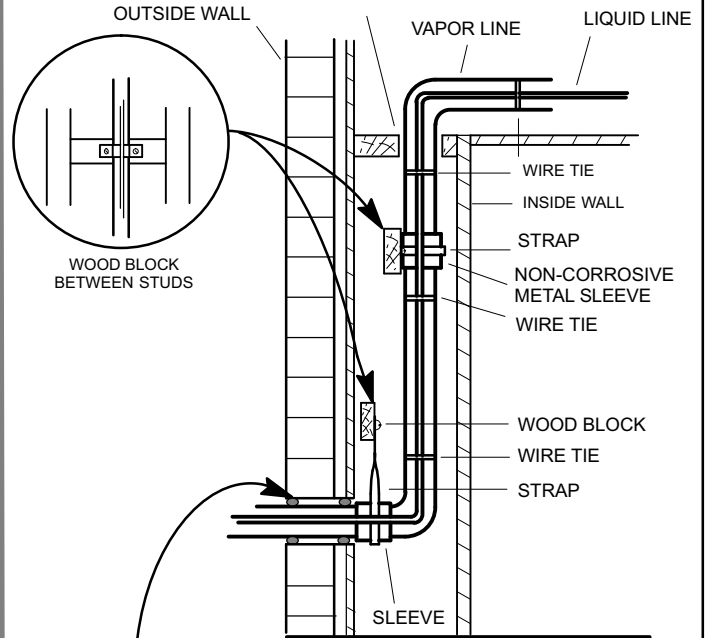

REFRIGERANT LINE SET — INSTALLING HORIZONTAL RUNS

To hang line set from joist or rafter, use either metal strapping material or anchored heavy nylon wire ties.

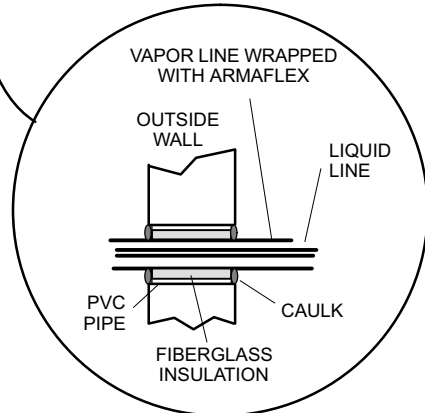
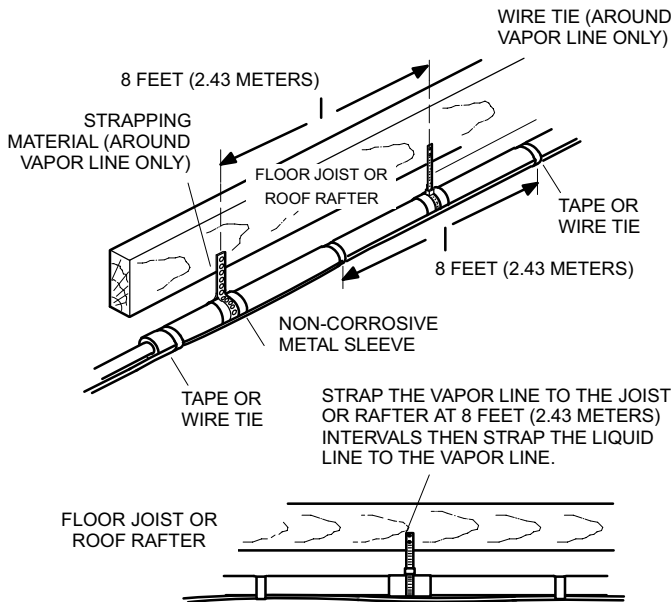

NOTE — Similar installation practices should be used if line set is to be installed on exterior of outside wall.

Figure 7. Line Set Installation

Brazing Connections

Use the procedures outline in figures 8 and 9 for brazing line set connections to service valves.

IMPORTANT

Polyol ester (POE) oils used with HFC-410A refrigerant absorb moisture very quickly. It is very important that the refrigerant system be kept closed as much as possible. **DO NOT** remove line set caps or service valve stub caps until you are ready to make connections.

WARNING



Danger of fire. Bleeding the refrigerant charge from only the high side may result in pressurization of the low side shell and suction tubing. Application of a brazing torch to a pressurized system may result in ignition of the refrigerant and oil mixture - Check the high and low pressures before applying heat.

CAUTION

Brazing alloys and flux contain materials which are hazardous to your health.

Avoid breathing vapors or fumes from brazing operations. Perform operations only in well-ventilated areas.

Wear gloves and protective goggles or face shield to protect against burns.

Wash hands with soap and water after handling brazing alloys and flux.

IMPORTANT

Allow braze joint to cool before removing the wet rag from the service valve. Temperatures above 250°F can damage valve seals.

IMPORTANT

Use silver alloy brazing rods with 5% minimum silver alloy for copper-to-copper brazing. Use 45% minimum alloy for copper-to-brass and copper-to-steel brazing.

WARNING



Fire, Explosion and Personal Safety Hazard.

Failure to follow this warning could result in damage, personal injury or death.

Never use oxygen to pressurize or purge refrigeration lines. Oxygen, when exposed to a spark or open flame, can cause fire and/or an explosion, that could result in property damage, personal injury or death.

WARNING



When using a high pressure gas such as dry nitrogen to pressurize a refrigeration or air conditioning system, use a regulator that can control the pressure down to 1 or 2 psig (6.9 to 13.8 kPa).

1 CUT AND DEBUR

Cut ends of the refrigerant lines square (free from nicks or dents) and debur the ends. The pipe must remain round. Do not crimp end of the line.

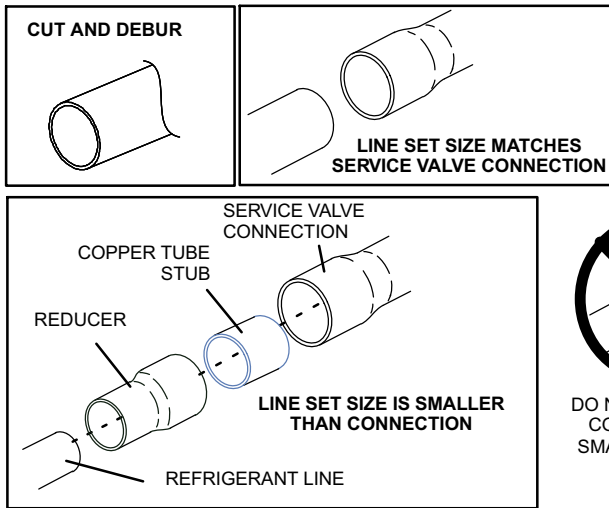

2 CAP AND CORE REMOVAL

Remove service cap and core from both the suction / vapor and liquid line service ports.

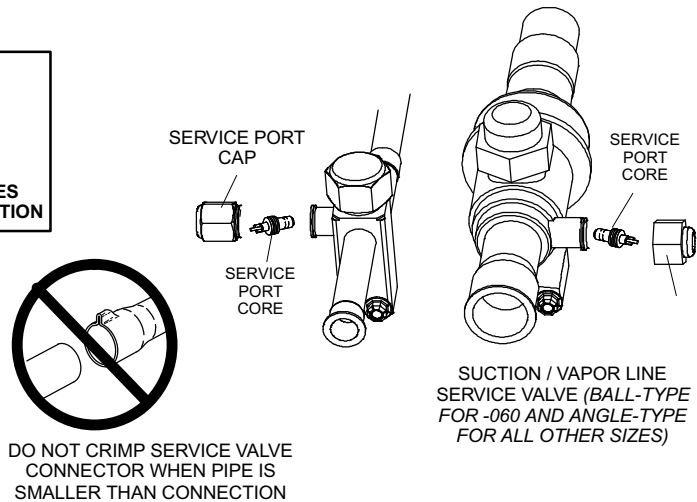

3 ATTACH THE MANIFOLD GAUGE SET FOR BRAZING LIQUID AND SUCTION / VAPOR LINE SERVICE VALVES

Flow regulated nitrogen (at 1 to 2 psig) through the low-side refrigeration gauge set into the liquid line service port valve, and out of the suction / vapor line service port valve.

- A Connect gauge set low pressure side to liquid line service valve (service port).
- B Connect gauge set center port to bottle of nitrogen with regulator.
- C Remove core from valve in suction / vapor line service port to allow nitrogen to escape.

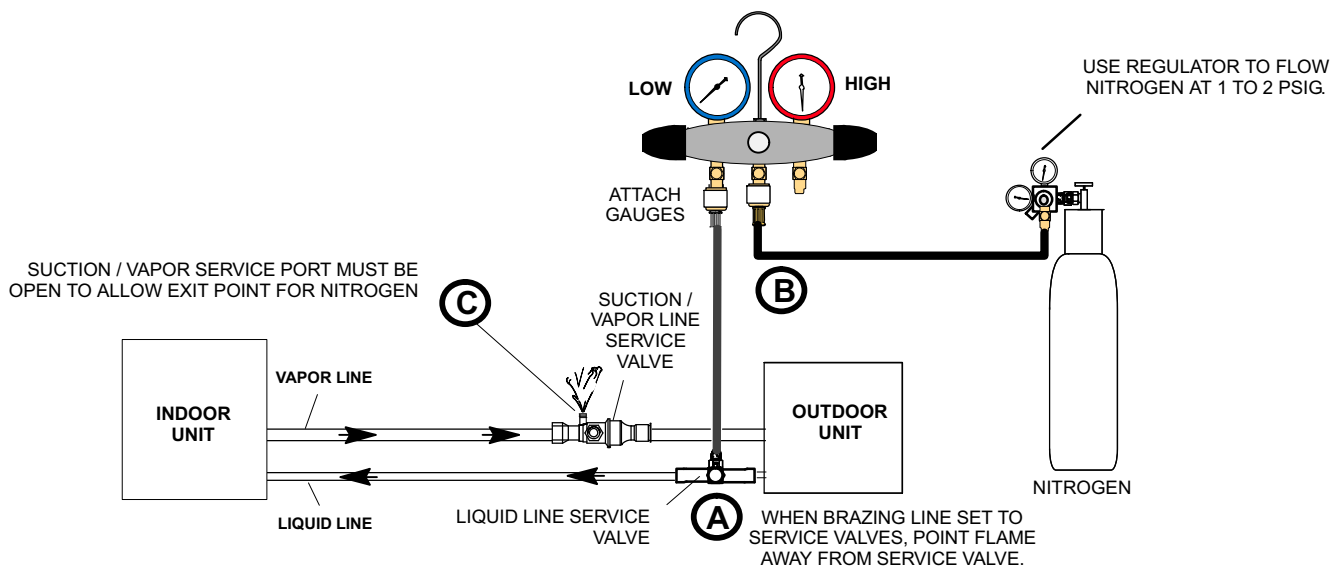

Figure 8. Brazing Procedures

4 WRAP SERVICE VALVES

To help protect service valve seals during brazing, wrap water saturated cloths around service valve bodies and copper tube stubs. Use additional water saturated cloths underneath the valve body to protect the base paint.

5 FLOW NITROGEN

Flow regulated nitrogen (at 1 to 2 psig) through the refrigeration gauge set into the valve stem port connection on the liquid service valve and out of the suction / vapor valve stem port. See steps **3A**, **3B** and **3C** on manifold gauge set connections

6 BRAZE LINE SET

Wrap both service valves with water saturated cloths as illustrated here and as mentioned in step 4, before brazing to line set. Water saturated cloths must remain water saturated throughout the brazing and cool-down process.

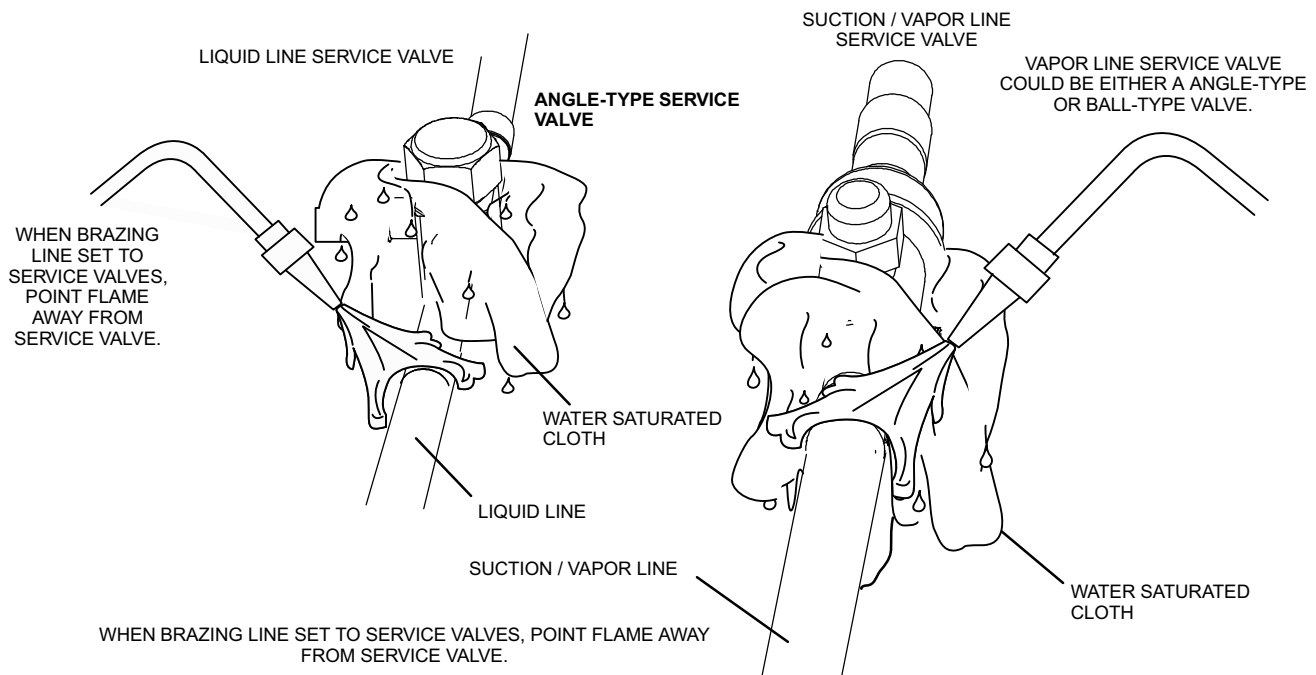

7 PREPARATION FOR NEXT STEP

After all connections have been brazed, disconnect manifold gauge set from service ports. Apply additional water saturated cloths to both service valves to cool piping. Once piping is cool, remove all water saturated cloths.

Figure 9. Brazing Procedures (continued)

⚠ IMPORTANT

Allow braze joint to cool. Apply additional water saturated cloths to help cool brazed joint. Do not remove water saturated cloths until piping has cooled. Temperatures above 250°F will damage valve seals.

⚠ WARNING



FIRE, PERSONAL INJURY, OR PROPERTY DAMAGE may result if you do not wrap a water saturated cloth around both liquid and suction line service valve bodies and copper tube stub while brazing in the line set! The braze, when complete, must be quenched with water to absorb any residual heat. Do not open service valves until refrigerant lines and indoor coil have been leak-tested and evacuated. Refer to procedures provided in this supplement.

Indoor Refrigerant Metering Device Removal and Flushing Line Set and Indoor Coil

Flushing is only required when the existing system used HCFC-22 refrigerant. If the existing system used HFC-410a, then remove the original indoor coil metering device and proceed to **Installing New Indoor Metering Device** on page .

1A TYPICAL EXISTING FIXED ORIFICE REMOVAL PROCEDURE (UNCASED OR COIL SHOWN)

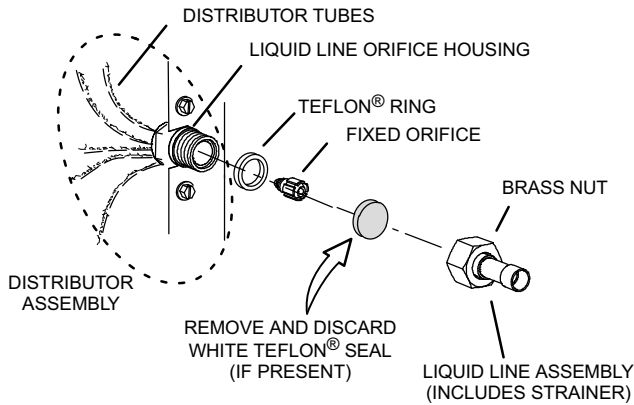

- A** On fully cased coils, remove the coil access and plumbing panels.
- B** Remove any shipping clamps holding the liquid line and distributor assembly.
- C** Using two wrenches, disconnect liquid line from liquid line orifice housing. Take care not to twist or damage distributor tubes during this process.
- D** Remove and discard fixed orifice, valve stem assembly if present and Teflon® washer as illustrated above.
- E** Use a field-provided fitting to temporary reconnect the liquid line to the indoor unit's liquid line orifice housing.

1B TYPICAL EXISTING EXPANSION VALVE REMOVAL PROCEDURE (UNCASED COIL SHOWN)

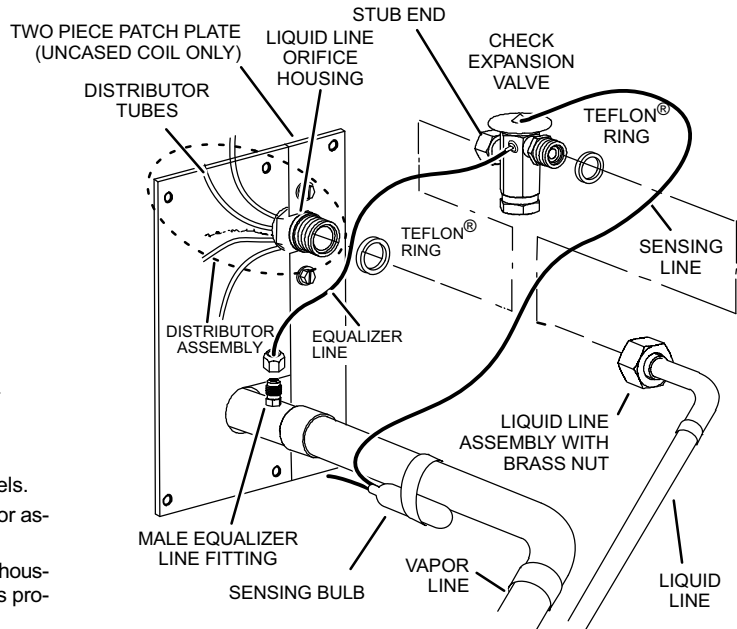

- A** On fully cased coils, remove the coil access and plumbing panels.
- B** Remove any shipping clamps holding the liquid line and distributor assembly.
- C** Disconnect the equalizer line from the check expansion valve equalizer line fitting on the vapor line.
- D** Remove the vapor line sensing bulb.
- E** Disconnect the liquid line from the check expansion valve at the liquid line assembly.
- F** Disconnect the check expansion valve from the liquid line orifice housing. Take care not to twist or damage distributor tubes during this process.
- G** Remove and discard check expansion valve and the two Teflon® rings.
- H** Use a field-provided fitting to temporary reconnect the liquid line to the indoor unit's liquid line orifice housing.

2 CONNECT GAUGES AND EQUIPMENT FOR FLUSHING PROCEDURE

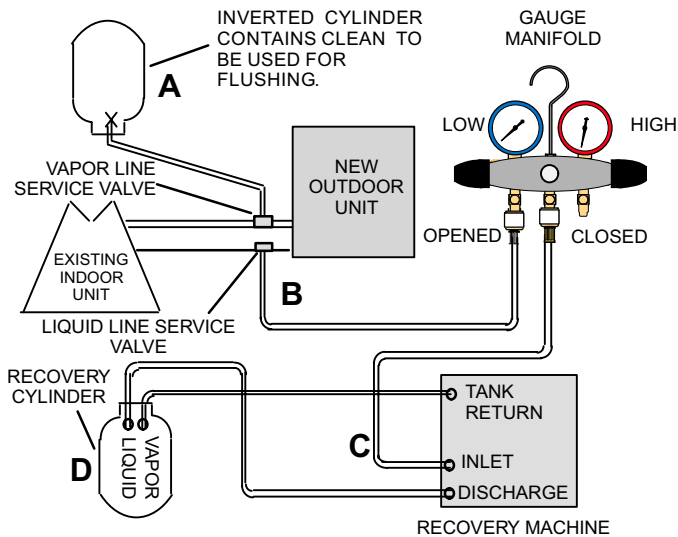

- A** Inverted cylinder with clean refrigerant to the vapor service valve.
- B** gauge set (low side) to the liquid line valve.
- C** gauge set center port to inlet on the recovery machine with an empty recovery tank to the gauge set.
- D** Connect recovery tank to recovery machines per machine instructions.

3 FLUSHING LINE SET

The line set and indoor unit coil must be flushed with at least the same amount of clean refrigerant that previously charged the system. Check the charge in the flushing cylinder before proceeding.

- A** Set the recovery machine for liquid recovery and start the recovery machine. Open the gauge set valves to allow the recovery machine to pull a vacuum on the existing system line set and indoor unit coil.
- B** Invert the cylinder of clean and open its valve to allow liquid refrigerant to flow into the system through the vapor line valve. Allow the refrigerant to pass from the cylinder and through the line set and the indoor unit coil before it enters the recovery machine.
- C** After all of the liquid refrigerant has been recovered, switch the recovery machine to vapor recovery so that all of the vapor is recovered. Allow the recovery machine to pull down to 0 the system.
- D** Close the valve on the inverted drum and the gauge set valves. Pump the remaining refrigerant out of the recovery machine and turn the machine off.

Figure 10. Removing Indoor Refrigerate Metering Device and Flushing Procedures

Installing New Indoor Metering Device

This outdoor unit is designed for use in HFC-410A systems that use a check / expansion valve metering device (purchased separately) at the indoor coil.

See the *Lennox 13HPX Engineering Handbook* for approved check / expansion valve kit match-ups. The check / expansion valve device can be installed either internal or external to the indoor coil. In applications where an uncased coil is being installed in a field-provided plenum, install the check / expansion valve in a manner that will provide access for field servicing of the check / expansion valve (see figure 11).

INDOOR EXPANSION VALVE INSTALLATION

(Uncased Coil Shown)

Labels in diagram: TWO PIECE PATCH PLATE (UNCASED COIL ONLY), LIQUID LINE ORIFICE HOUSING, STUB END EXPANSION VALVE, TEFLON® RING, SENSING LINE, DISTRIBUTOR TUBES, DISTRIBUTOR ASSEMBLY, EQUALIZER LINE, LIQUID LINE ASSEMBLY WITH BRASS NUT, VAPOR LINE, LIQUID LINE, MALE EQUALIZER LINE FITTING (SEE EQUALIZER LINE INSTALLATION FOR FURTHER DETAILS).

Sensing bulb insulation is required if mounted external to the coil casing. sensing bulb installation for bulb positioning.

- A** Remove the field-provided fitting that temporary reconnected the liquid line to the indoor unit's distributor assembly.
- B** Install one of the provided Teflon® rings around the stubbed end of the expansion valve and lightly lubricate the connector threads and expose surface of the Teflon® ring with refrigerant oil.
- C** Attach the stubbed end of the expansion valve to the liquid line orifice housing. Finger tighten and use an appropriately sized wrench to turn an additional 1/2 turn clockwise as illustrated in the figure above, or 20 ft-lb.
- D** Place the remaining Teflon® washer around the other end of the expansion valve. Lightly lubricate connector threads and expose surface of the Teflon® ring with refrigerant oil.
- E** Attach the liquid line assembly to the expansion valve. Finger tighten and use an appropriately sized wrench to turn an additional 1/2 turn clockwise as illustrated in the figure above or 20 ft-lb.

EQUALIZER LINE INSTALLATION

- A** Remove and discard either the flare seal cap or flare nut with copper flare seal bonnet from the equalizer line port on the vapor line as illustrated in the figure to the right.
- B** Remove and discard either the flare seal cap or flare nut with copper flare seal bonnet from the equalizer line port on the vapor line as illustrated in the figure to the right.

Labels in diagram: FLARE SEAL CAP, FLARE NUT, COPPER FLARE SEAL BONNET, MALE BRASS EQUALIZER LINE FITTING, VAPOR LINE.

SENSING BULB INSTALLATION

- A** Attach the vapor line sensing bulb in the proper orientation as illustrated to the right using the clamp and screws provided.

NOTE — Confirm proper thermal contact between vapor line and expansion bulb before insulating the sensing bulb once installed.

- B** Connect the equalizer line from the expansion valve to the equalizer vapor port on the vapor line. Finger tighten the flare nut plus 1/8 turn (7 ft-lbs) as illustrated below.

Labels in diagram: VAPOR LINE, BULB.

ON LINES SMALLER THAN 7/8", MOUNT SENSING BULB AT EITHER THE 3 OR 9 O'CLOCK POSITION.

ON 7/8" AND LARGER LINES, MOUNT SENSING BULB AT EITHER THE 4 OR 8 O'CLOCK POSITION. NEVER MOUNT ON BOTTOM OF LINE.

NOTE — NEVER MOUNT ON BOTTOM OF LINE.

Figure 11. Installing Indoor Check / Expansion Valve

! IMPORTANT

Leak detector must be capable of sensing HFC refrigerant.

CONNECT GAUGE SET

- A** Connect an HFC-410A manifold gauge set high pressure hose to the vapor valve service port.

NOTE — Normally, the high pressure hose is connected to the liquid line port. However, connecting it to the vapor port better protects the manifold gauge set from high pressure damage.

- B** With both manifold valves closed, connect the cylinder of HFC-410A refrigerant to the center port of the manifold gauge set.

NOTE — Later in the procedure, the HFC-410A container will be replaced by the nitrogen container.

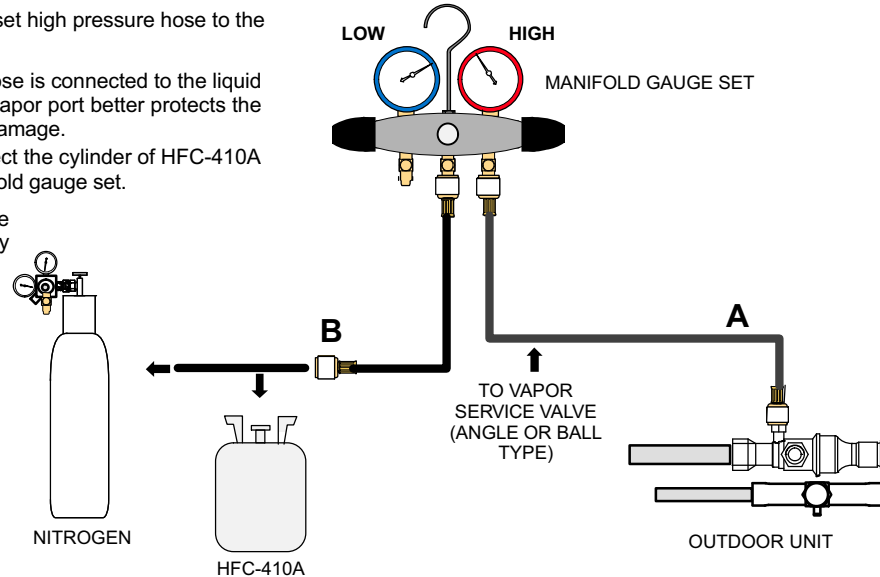

Figure 12. Manifold Gauge Set Connections for Leak Testing

TEST FOR LEAKS

After the line set has been connected to the indoor and outdoor units, check the line set connections and indoor unit for leaks. Use the following procedure to test for leaks:

1. With both manifold valves closed, connect the cylinder of HFC-410A refrigerant to the center port of the manifold gauge set. Open the valve on the HFC-410A cylinder (vapor only).
2. Open the high pressure side of the manifold to allow HFC-410A into the line set and indoor unit. Weigh in a trace amount of HFC-410A. [A trace amount is a maximum of two ounces (57 g) refrigerant or three pounds (31 kPa) pressure]. Close the valve on the HFC-410A cylinder and the valve on the high pressure side of the manifold gauge set. Disconnect the HFC-410A cylinder.
3. Connect a cylinder of dry nitrogen with a pressure regulating valve to the center port of the manifold gauge set.
4. Adjust dry nitrogen pressure to 150 psig (1034 kPa). Open the valve on the high side of the manifold gauge set in order to pressurize the line set and the indoor unit.
5. After a few minutes, open one of the service valve ports and verify that the refrigerant added to the system earlier is measurable with a leak detector.
6. After leak testing disconnect gauges from service ports.

Evacuating Line Set and Indoor Coil

Evacuating the system of non-condensables is critical for proper operation of the unit. Non-condensables are defined as any gas that will not condense under temperatures and pressures present during operation of an air conditioning system. Non-condensables and water suction combine with refrigerant to produce substances that corrode copper piping and compressor parts.

1 CONNECT GAUGE SET

NOTE — Remove cores from service valves (if not already done).

- A** Connect low side of manifold gauge set with 1/4 SAE in-line tee to vapor line service valve
- B** Connect high side of manifold gauge set to liquid line service valve
- C** Connect micron gauge available connector on the 1/4 SAE in-line tee.
- D** Connect the vacuum pump (with vacuum gauge) to the center port of the manifold gauge set. The center port line will be used later for both the HFC-410A and nitrogen containers.

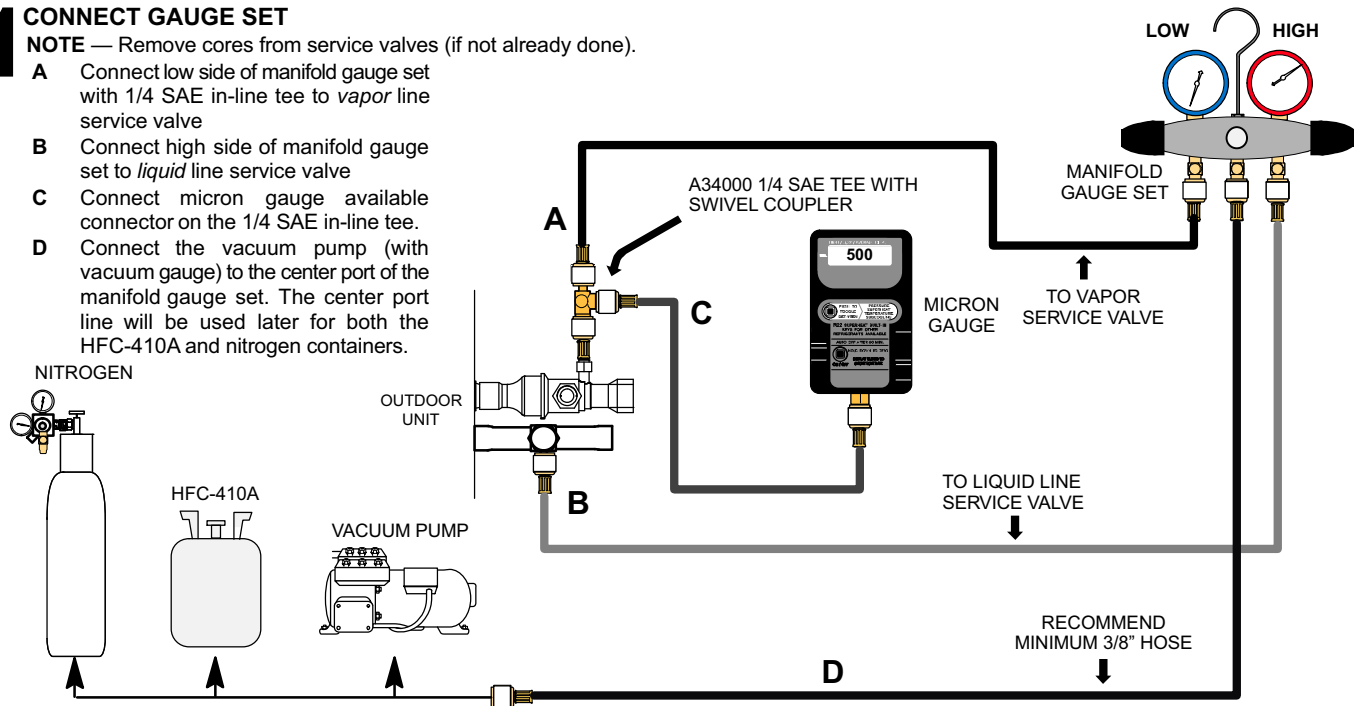

2 EVACUATE THE SYSTEM

- A** Open both manifold valves and start the vacuum pump.
- B** Evacuate the line set and indoor unit to an **absolute pressure** of 23,000 microns (29.01 inches of mercury).

NOTE — During the early stages of evacuation, it is desirable to close the manifold gauge valve at least once. A rapid rise in pressure indicates a relatively large leak. If this occurs, **repeat the leak testing procedure**.

NOTE — The term **absolute pressure** means the total actual pressure within a given volume or system, above the absolute zero of pressure. Absolute pressure in a vacuum is equal to atmospheric pressure minus vacuum pressure.
- C** When the absolute pressure reaches 23,000 microns (29.01 inches of mercury), perform the following:
 - Close manifold gauge valves
 - Close valve on vacuum pump and turn off vacuum pump
 - Disconnect manifold gauge center port hose from vacuum pump
 - Attach manifold center port hose to a dry nitrogen cylinder with pressure regulator set to 150 psig (1034 kPa) and purge the hose.
 - Open manifold gauge valves to break the vacuum in the line set and indoor unit.
 - Close manifold gauge valves.
- D** Shut off the dry nitrogen cylinder and remove the manifold gauge hose from the cylinder. Open the manifold gauge valves to release the dry nitrogen from the line set and indoor unit.
- E** Reconnect the manifold gauge to the vacuum pump, turn the pump on, and continue to evacuate the line set and indoor unit until the absolute pressure does not rise above 500 microns (29.9 inches of mercury) within a 20-minute period after shutting off the vacuum pump and closing the manifold gauge valves.
- F** When the absolute pressure requirement above has been met, disconnect the manifold hose from the vacuum pump and connect it to an upright cylinder of HFC-410A refrigerant. Open the manifold gauge valve 1 to 2 psig in order to release the vacuum in the line set and indoor unit.
- G** Perform the following:
 - Close manifold gauge valves.
 - Shut off HFC-410A cylinder.
 - Reinstall service valve cores by removing manifold hose from service valve. Quickly install cores with core tool while maintaining a positive system pressure.
 - Replace stem caps and secure finger tight, then tighten an additional one-sixth (1/6) of a turn as illustrated.

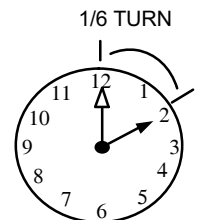

Figure 13. Evacuating Line Set and Indoor Coil

⚠ IMPORTANT

Use a thermocouple or thermistor electronic vacuum gauge that is calibrated in microns. Use an instrument capable of accurately measuring down to 50 microns.

⚠ WARNING

Danger of Equipment Damage. Avoid deep vacuum operation. Do not use compressors to evacuate a system. Extremely low vacuums can cause internal arcing and compressor failure. Damage caused by deep vacuum operation will void warranty.

SIZE CIRCUIT AND INSTALL SERVICE DISCONNECT SWITCH

Refer to the unit nameplate for minimum circuit ampacity, and maximum fuse or circuit breaker (HACR per NEC). Install power wiring and properly sized disconnect switch.

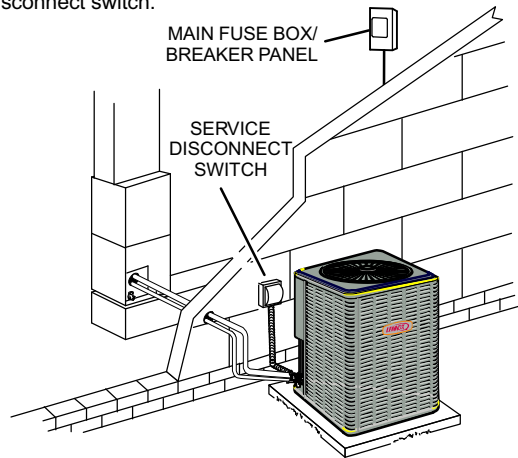

NOTE — Units are approved for use only with copper conductors. Ground unit at disconnect switch or to an earth ground.

Electrical Connections

In the U.S.A., wiring must conform with current local codes and the current National Electric Code (NEC). In Canada, wiring must conform with current local codes and the current Canadian Electrical Code (CEC).

Refer to the furnace or air handler installation instructions for additional wiring application diagrams and refer to unit nameplate for minimum circuit ampacity and maximum overcurrent protection size.

24VAC TRANSFORMER

Use the transformer provided with the furnace or air handler for low-voltage control power (24VAC - 40 VA minimum)

INSTALL THERMOSTAT

Install room thermostat (ordered separately) on an inside wall approximately in the center of the conditioned area and 5 feet (1.5m) from the floor. It should not be installed on an outside wall or where it can be affected by sunlight or drafts.

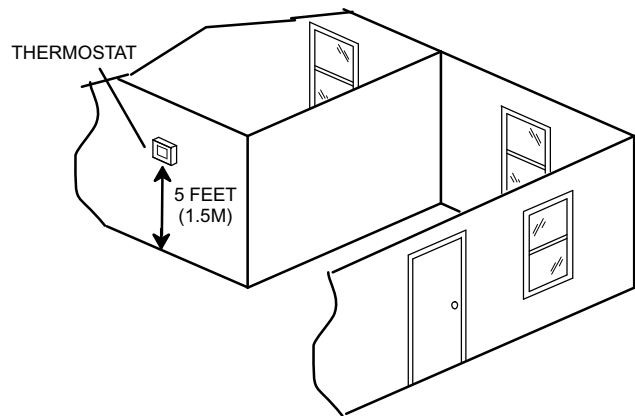

NOTE — 24VAC, Class II circuit connections are made in the control panel.

⚠ WARNING



Electric Shock Hazard. Can cause injury or death. Unit must be grounded in accordance with national and local codes.

Line voltage is present at all components when unit is not in operation on units with single-pole contactors. Disconnect all remote electric power supplies before opening access panel. Unit may have multiple power supplies.

ROUTING HIGH VOLTAGE/ GROUND AND CONTROL WIRING

HIGH VOLTAGE / GROUND WIRES

Any excess high voltage field wiring should be trimmed and secured away from any low voltage field wiring. To facilitate a conduit, a cutout is located in the bottom of the control panel. Connect conduit to the control panel using a proper conduit fitting.

CONTROL WIRING

Install low voltage wiring from outdoor to indoor unit and from thermostat to indoor unit as illustrated.

- A** Run 24VAC control wires through hole with grommet.
- B** Make 24VAC thermostat wire connections to CMC1.

NOTE — Do not bundle any excess 24VAC control wires inside control panel.

NOTE — For proper voltages, select thermostat wire (control wires) gauge per table below.

WIRE RUN LENGTH	AWG#	INSULATION TYPE
LESS THAN 100' (30 METERS)	18	TEMPERATURE RATING
MORE THAN 100' (30 METERS)	16	35°C MINIMUM.

- HIGH VOLTAGE FIELD WIRING
- LOW VOLTAGE FIELD WIRING
- FACTORY WIRING

SINGLE PHASE

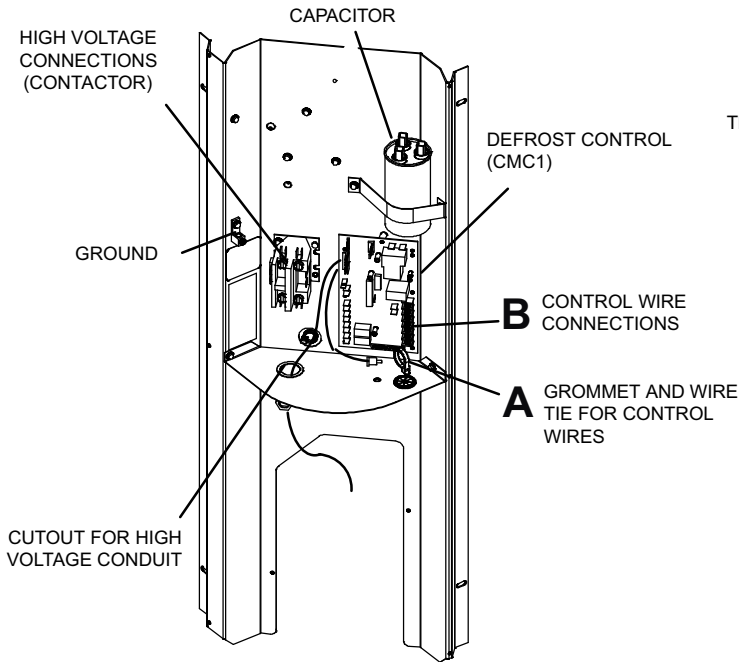

NOTE — Wire tie provides low voltage wire strain relief and to maintain separation of field installed low and high voltage circuits.

TYPICAL CONTROL WIRING

Low Voltage Wiring

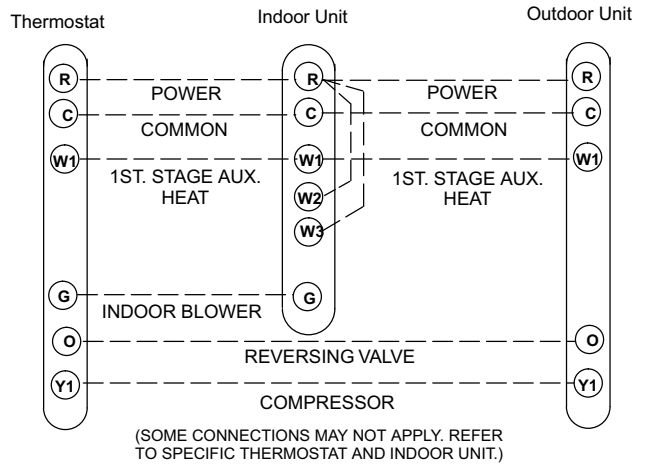

Low Voltage Wiring (with Auxiliary Heat)

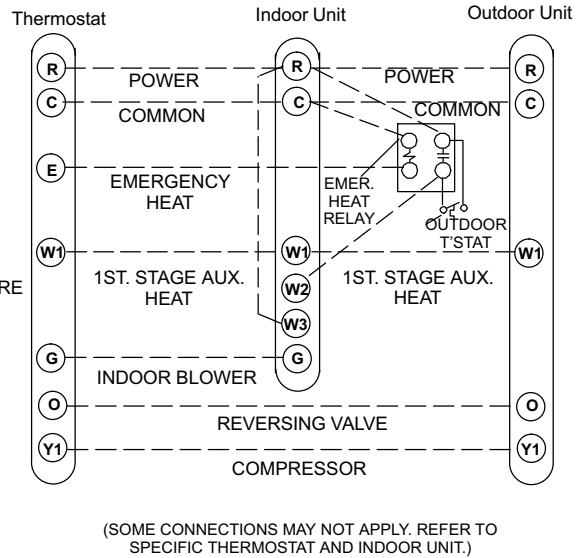

Figure 14. Connections

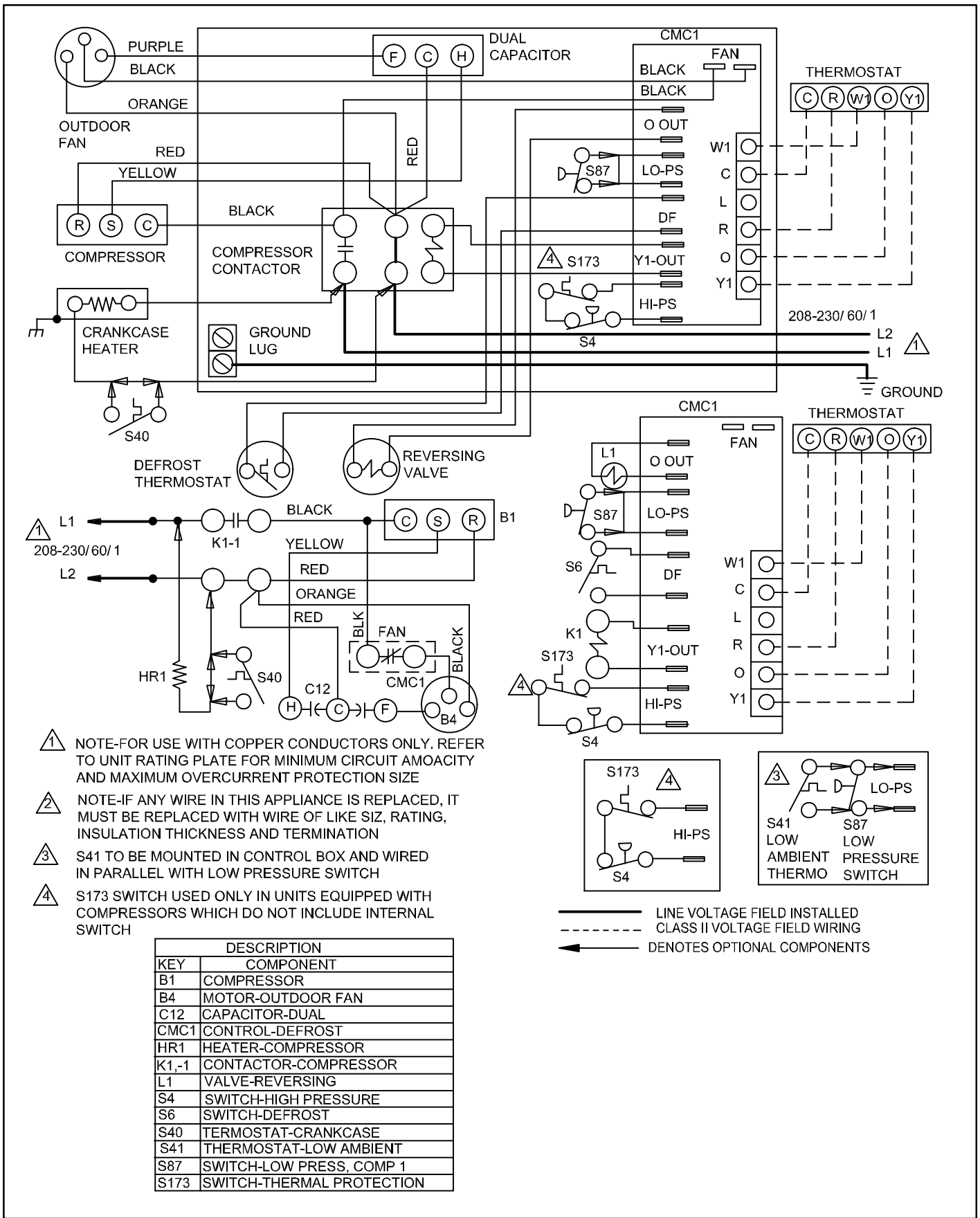

Figure 15. Typical Unit Wiring Diagram

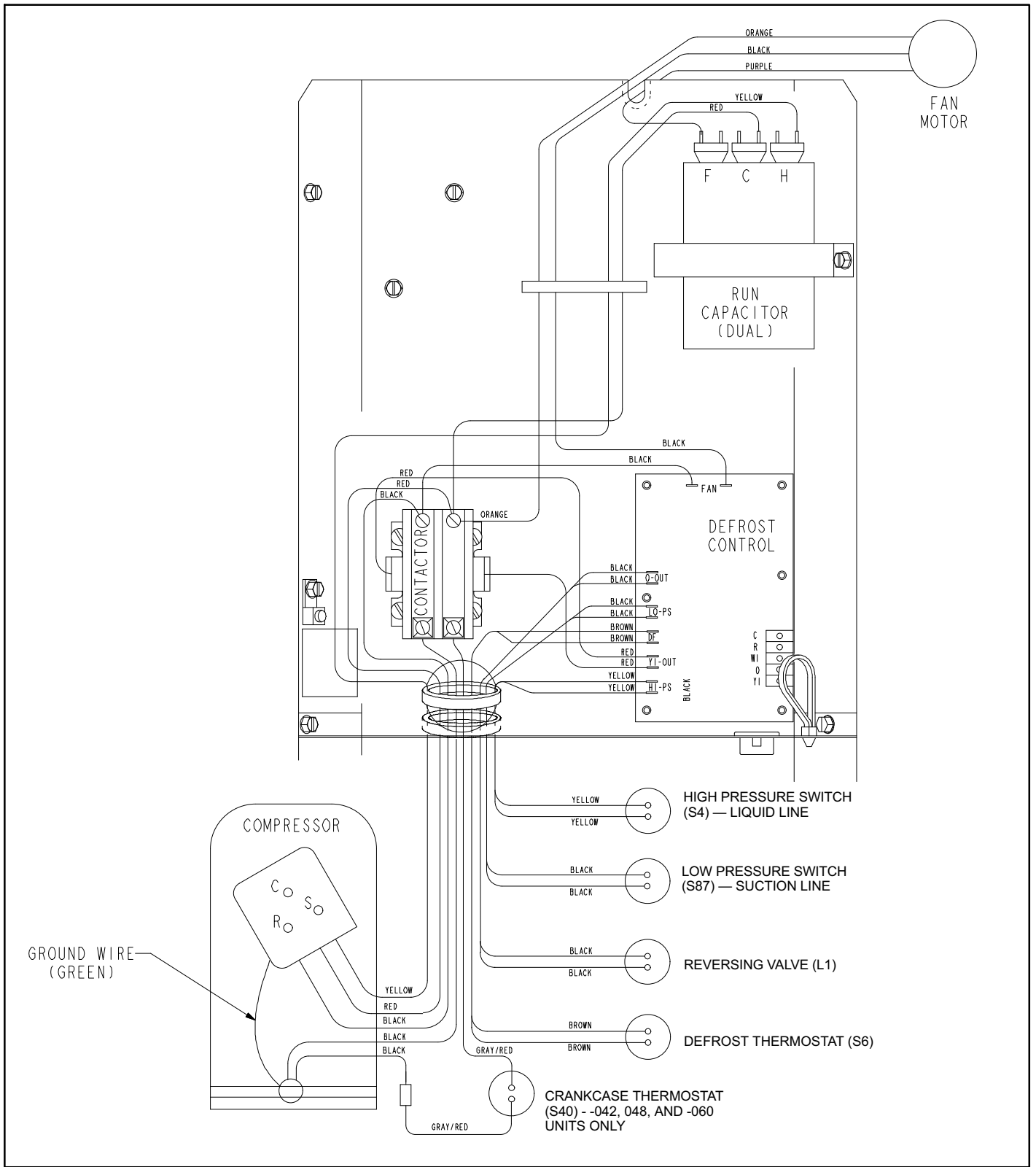

Figure 16. Typical Unit Factory Wiring

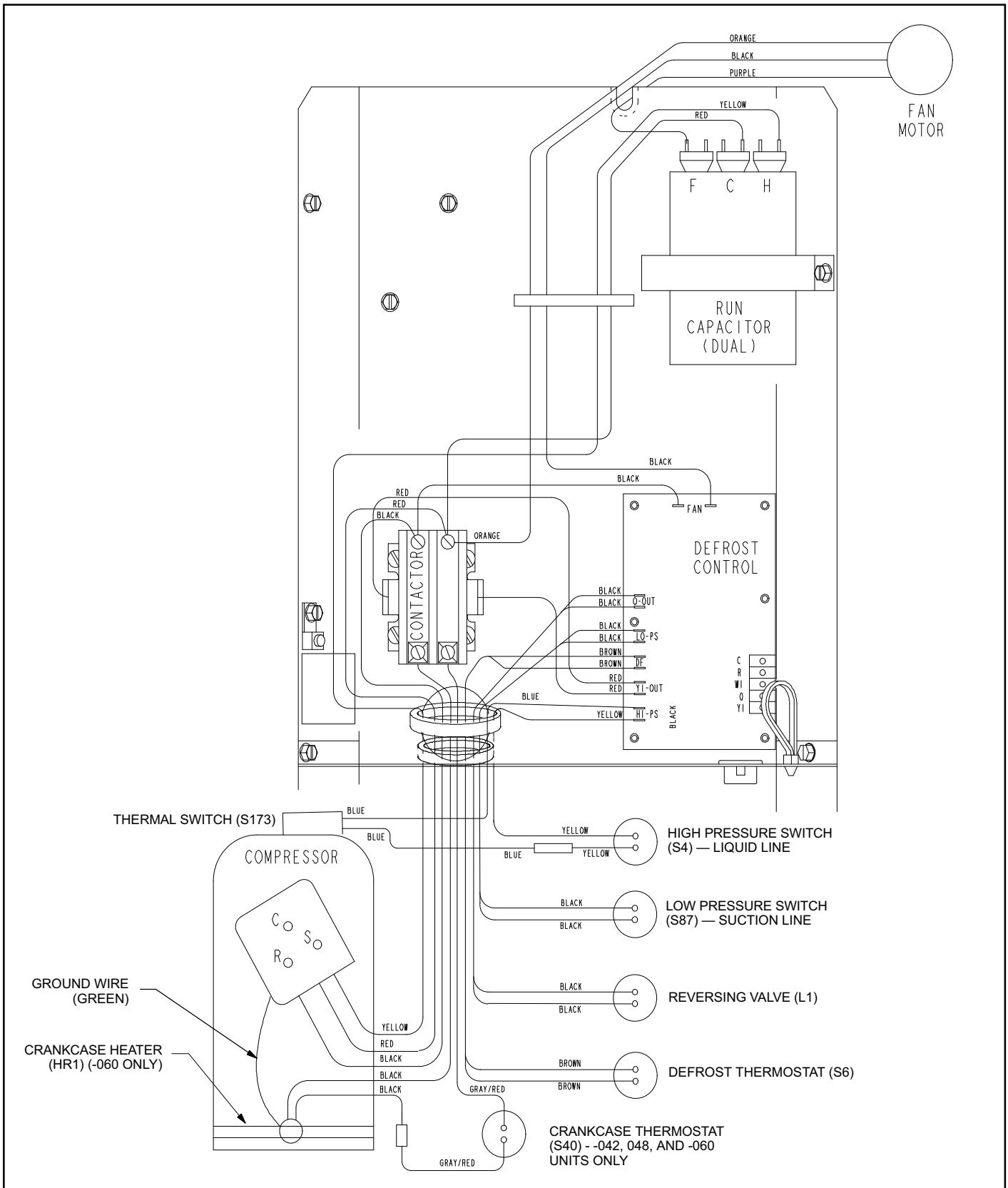

Figure 17. Typical Unit Factory Wiring — Compressor with Thermal Protection Switch (S173)

Unit Start-Up

IMPORTANT

If unit is equipped with a crankcase heater, it should be energized 24 hours before unit start-up to prevent compressor damage as a result of slugging.

UNIT START-UP

1. Rotate fan to check for binding.
2. Inspect all factory- and field-installed wiring for loose connections.
3. Verify that the manifold gauge set is connected as illustrated in figure 19. Use a temperature sensor positioned near the liquid line service port as illustrated in figure 19 which will be required later when using the subcooling method for optimizing the system refrigerant charge.
4. Replace the stem caps and tighten to the value listed in table 1.
5. Check voltage supply at the disconnect switch. The voltage must be within the range listed on the unit's nameplate. If not, do not start the equipment until you have consulted with the power company and the voltage condition has been corrected.
6. Open both the liquid and vapor line service valves to release the refrigerant charge contained in outdoor unit into the system.
7. Use figure 18 to determine next step in system preparation.

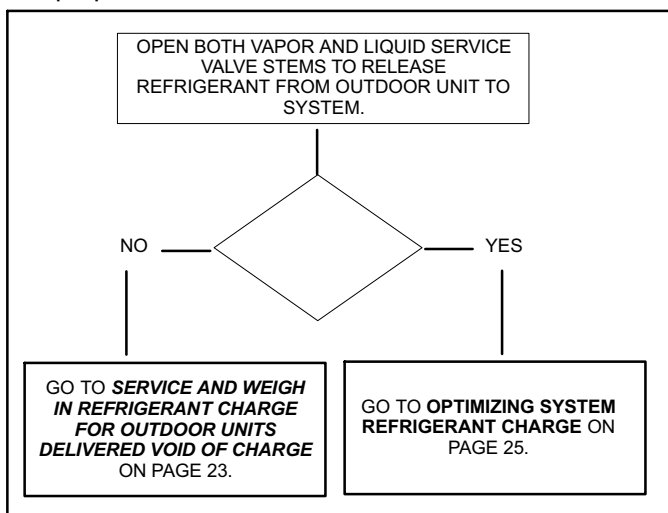

Figure 18. Outdoor Unit Factory Charge

Service and Weigh In Refrigerant for Outdoor Units Delivered Void of Charge

The following procedures are only required if it has been determined that the new outdoor unit is void of charge. Skip to the next section if refrigerant charge is present.

LEAK CHECK, REPAIR AND EVACUATE

If the outdoor unit is void of refrigerant, clean the system using the procedure described below.

1. Leak check system using procedures provided on page 16. Repair any leaks discovered during leak test.
2. Evacuate the system using procedure provided in figure 13.
3. Use nitrogen to break the vacuum and install a new filter drier in the system.
4. Evacuate the system again using procedure in figure 13.

CONNECT MANIFOLD GAUGE SET AND WEIGH IN CHARGE

After the evacuation procedure, reconnect the manifold gauge set as illustrated in figure 19.

NOTE - Temperature sensor illustrated in figure 19 is not required for initial system weigh in charging.

1. Close manifold gauge set valves and connect the gauge set as exemplified in figure 19.
2. Check that fan rotates freely.
3. Inspect all factory- and field-installed wiring for loose connections.
4. Open the high side manifold gauge valve and weigh in liquid refrigerant. Use figure 20 to calculate the correct weigh-in charge.
5. Close manifold gauge valves.
6. Monitor the system to determine the amount of moisture remaining in the oil. It may be necessary to replace the bi-flow filter drier several times to achieve the required dryness level. If system dryness is not verified, the compressor will fail in the future.
7. Continue to **Optimizing System Refrigerant Charge** on page 25 to optimize the system charge using subcooling method.

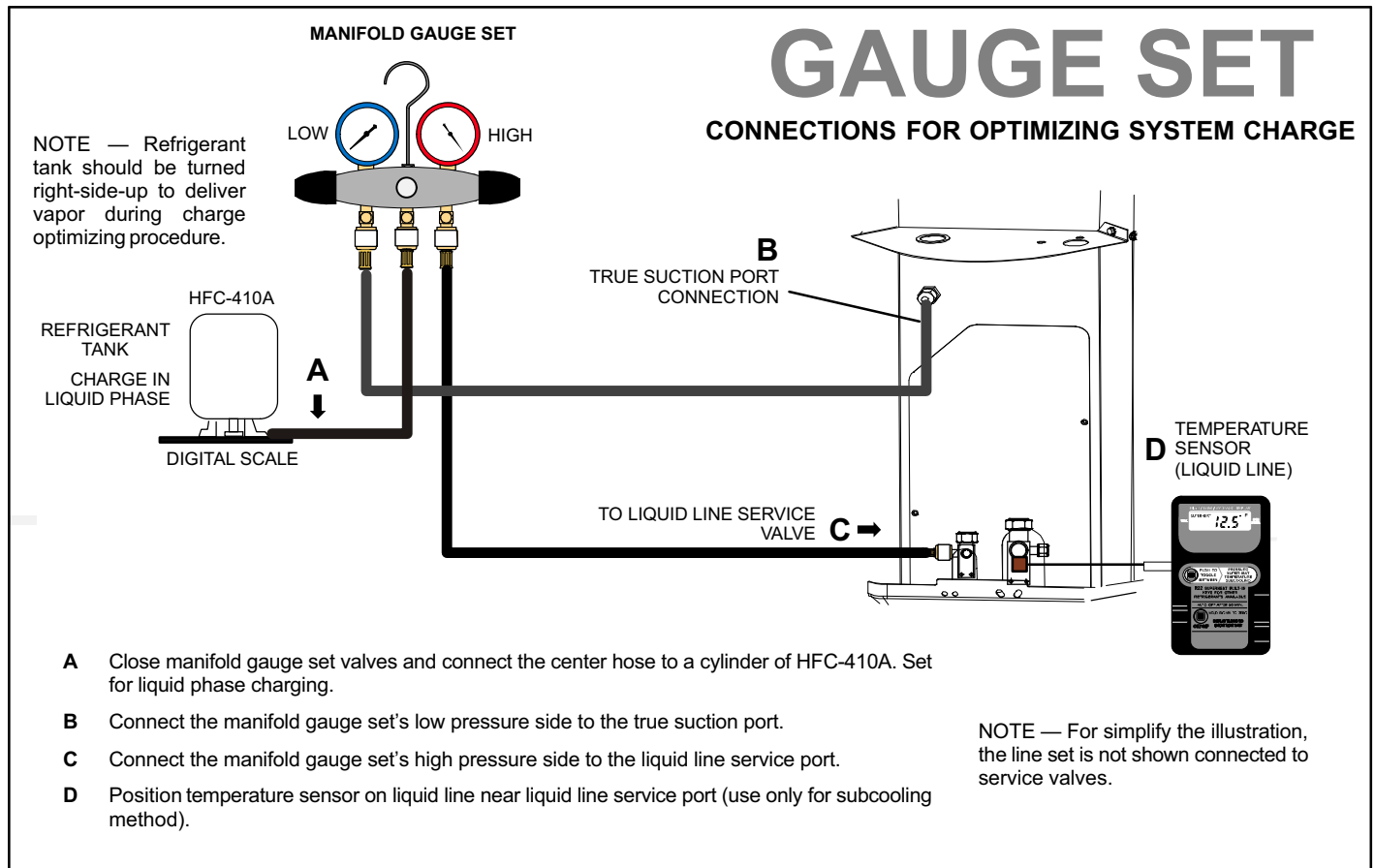

Figure 19. Typical Gauge Set Connections for Initial Weight-in Charge or Optimizing System Charge

WEIGH-IN CHARGING

CALCULATING SYSTEM CHARGE FOR OUTDOOR UNIT VOID OF CHARGE

If the system is void of refrigerant, first, locate and repair any leaks and then weigh in the refrigerant charge into the unit. To calculate the total refrigerant charge:

Amount specified on nameplate	±	Adjust amount, for variation in line set length listed on line set length table below.	+	Additional charge specified per match indoor air handler or coil listed in table 3.	=	Total Charge
_____		_____		_____		_____

Refrigerant Charge per Line Set Length

LIQUID LINE SET DIAMETER	OUNCES PER 5 FEET (GRAMS PER 1.5 METERS) ADJUST FROM 15 FEET (4.6 METERS) LINE SET*
3/8" (9.5 MM)	3 OUNCE PER 5' (85 GRAMS PER 1.5 M)

*If line length is greater than 15 feet (4.6 meters), add this amount. If line length is less than 15 feet (4.6 meters), subtract this amount.

NOTE — Insulate liquid line when it is routed through areas where the surrounding ambient temperature could become higher than the temperature of the liquid line or when pressure drop is equal to or greater than 20 psig.

NOTE — The above nameplate is for illustration purposes only. Go to actual nameplate on outdoor unit for charge information.

Figure 20. Using HFC-410A Weigh In Method

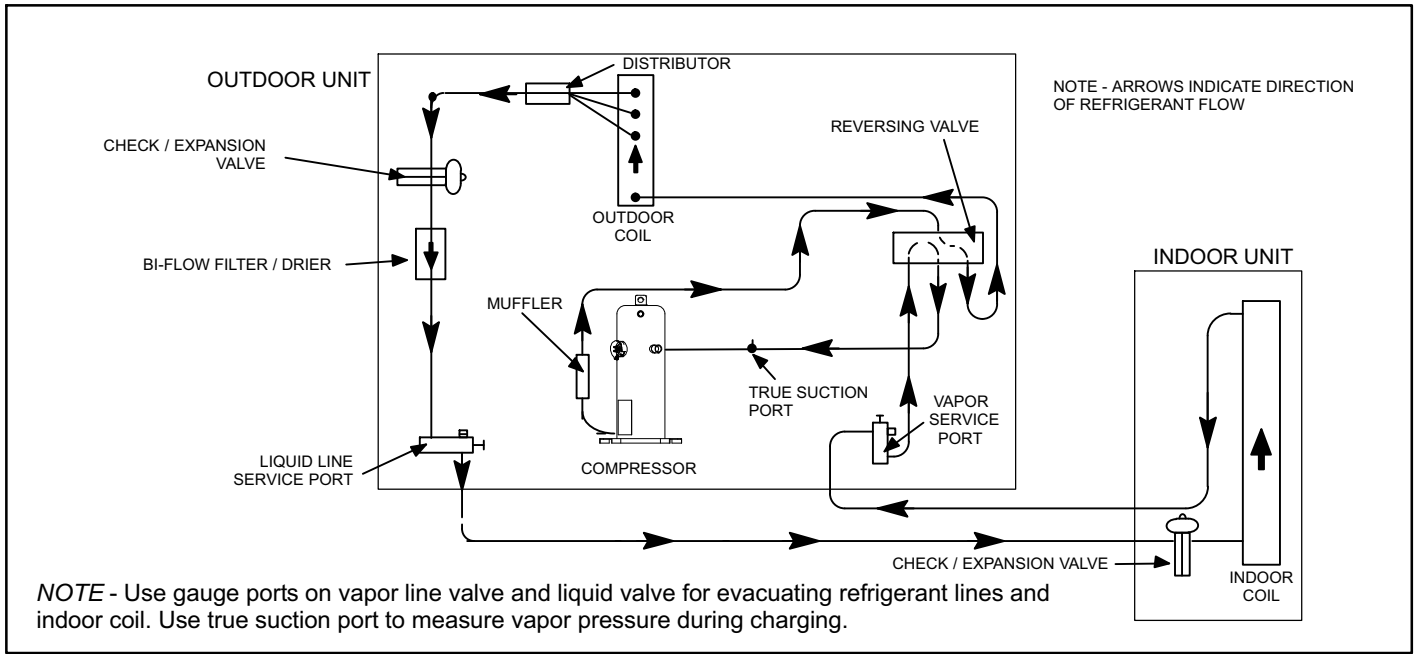

Figure 21. Heat Pump Cooling Cycle

Optimizing System Refrigerant Charge

This section provides instructions on optimizing the system charge. This section includes:

- Optimizing procedure
- Adjusting indoor airflow
- Using subcooling method
- Approved matched components, targeted subcooling (SC) values and add charge values
- Normal operating pressures
- Temperature pressures

OPTIMIZING PROCEDURE

1. Move the low-side manifold gauge hose from the vapor line service valve to the true suction port (see figure 19).
2. Set the thermostat for either cooling or heating demand. Turn on power to the indoor unit and close the outdoor unit disconnect switch to start the unit.
3. Allow unit to run for five minutes to allow pressures to stabilize.
4. Check the airflow as instructed under *Adjusting Indoor Airflow* to verify or adjust indoor airflow for maximum

efficiency. Make any air flow adjustments before continuing with the optimizing procedure.

5. Use **subcooling method to optimize the system charge** (see figure 23). Adjust charge as necessary.

ADJUSTING INDOOR AIRFLOW

Heating Mode Indoor Airflow Check (Only use when indoor unit has electric heat)

Indoor blower airflow (CFM) may be calculated by energizing electric heat and measuring:

- Temperature rise between the return air and supply air temperatures at the indoor coil blower unit,
- Measuring voltage supplied to the unit,
- Measuring amperage being drawn by the heat unit(s).

Then, apply the measurements taken in the following formula to determine CFM:

$$\text{CFM} = \frac{\text{Amps} \times \text{Volts} \times 3.41}{1.08 \times \text{Temperature rise (F)}}$$

Cooling Mode Indoor Airflow Check

Check airflow using the Delta-T (DT) process using figure 22.

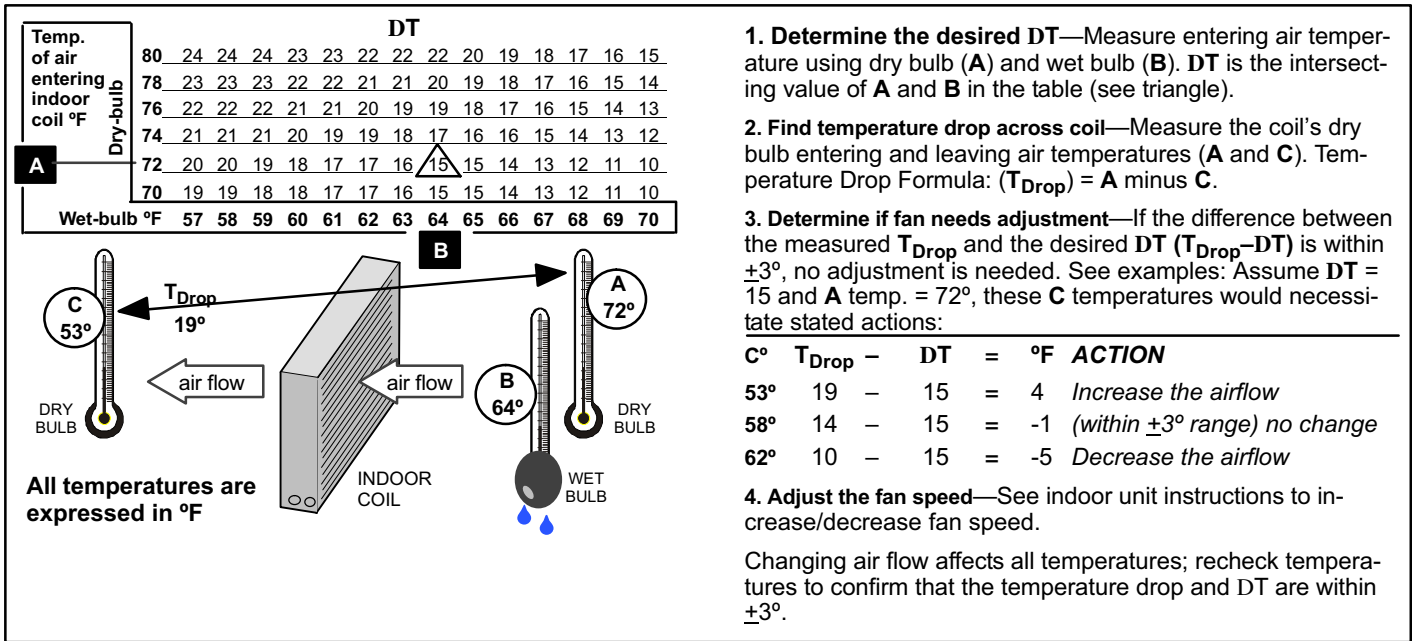

1. **Determine the desired DT**—Measure entering air temperature using dry bulb (A) and wet bulb (B). DT is the intersecting value of A and B in the table (see triangle).

2. **Find temperature drop across coil**—Measure the coil's dry bulb entering and leaving air temperatures (A and C). Temperature Drop Formula: (T_{Drop}) = A minus C.

3. **Determine if fan needs adjustment**—If the difference between the measured T_{Drop} and the desired DT (T_{Drop}–DT) is within ±3°, no adjustment is needed. See examples: Assume DT = 15 and A temp. = 72°, these C temperatures would necessitate stated actions:

C°	T _{Drop}	–	DT	=	°F	ACTION
53°	19	–	15	=	4	Increase the airflow
58°	14	–	15	=	-1	(within ±3° range) no change
62°	10	–	15	=	-5	Decrease the airflow

4. **Adjust the fan speed**—See indoor unit instructions to increase/decrease fan speed.

Changing air flow affects all temperatures; recheck temperatures to confirm that the temperature drop and DT are within ±3°.

Figure 22. Checking Airflow over Indoor Coil Using Delta-T Formula

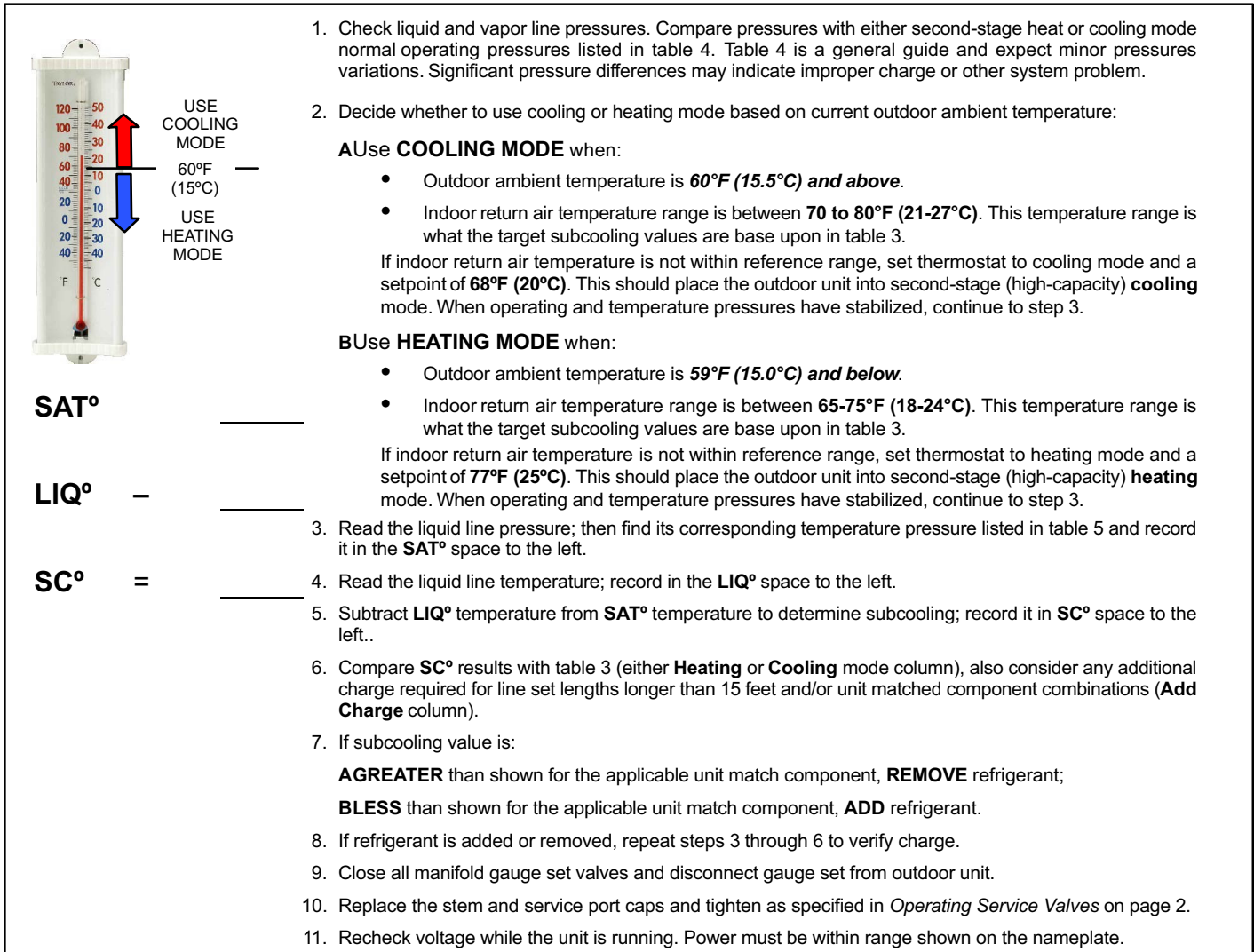

Figure 23. Using HFC-410A Subcooling Method — Second Stage (High Capacity) — Optimizing Charge

APPROVED MATCHED SYSTEM COMPONENTS, TARGETED SUBCOOLING (SC) VALUES AND ADD CHARGE VALUES

Listed below are the **approved matched system components** (air handlers and indoor coils), **targeted subcooling** and **add charge** values for the 13HPX. This information is also listed on the unit charging sticker located on the outdoor unit access panel.

Subcooling values listed in the following tables are based on outdoor ambient air temperature of:

- **60°F (15.5°C) and above** for cooling mode
- **59°F (15.0°C) and below** for heating mode.

Table 3 - Indoor Unit Matches, Targeted Subcooling and Add Charge Values

Size	Indoor Coil or Air Handler	Subcooling		*Additional Charge		Size	Indoor Coil or Air Handler	Subcooling		*Additional Charge		Size	Indoor Coil or Air Handler	Subcooling		*Additional Charge			
		Heat	Cool	Lbs	Oz.			Heat	Cool	Lbs	Oz.			Heat	Cool	Lbs	Oz.		
-018	CBX26UH-018	11	8	0	0	-030 (continued)	(continued)								-042 (continued)	(continued)			
	CBX27UH-024	11	14	1	1		CBX40UHV-036	9	22	1	0	CH33-48C	7	14		1	2		
	CBX32M-018/024	10	12	0	5		CH33-42B	10	7	0	0	CR33-50/60C	8	21		2	4		
	CBX32MV-024/030	11	14	1	1		CH33-31B	10	7	0	0	CX34-43B	8	14		1	13		
	CBX32MV-018/024	10	12	0	5		CR33-30/36AB/C	9	7	0	9	CX34-50/60C	8	14		1	13		
	CBX40UHV-024	10	18	1	8		CX34-31A/B	9	19	0	14	CBX26UH-048	7	7		1	2		
	CH33-25A	13	7	0	4		CBX26UH-036	19	15	0	0	CBX27UH-048	10	8		1	5		
	CH33-36A	13	7	0	4		CBX27UH-036	8	13	1	2	CBX27UH-060	8	10		1	9		
	CR33-30/36A/B/C	11	4	0	4		CBX32M-036	8	13	1	2	CBX32M-048	10	8		1	5		
	CX34-25A/B	11	12	0	3		CBX32MV-036	8	13	1	2	CBX32M-060	9	6		0	9		
-024	CBX26UH-024	12	12	1	9	-036	CBX40UHV-030	8	13	1	2	-048	CBX32MV-048	10	8	1	5		
	CBX27UH-024	12	18	1	15		CBX40UHV-036	8	13	1	2		CBX32MV-060	9	6	0	9		
	CBX27UH-030	11	22	1	6		CH33-36C	8	12	0	5		CBX40UHV-042	10	8	1	5		
	CBX32M-030	12	18	1	15		CH33-42B	8	7	0	0		CBX40UHV-048	10	8	1	5		
	CBX32MV-018/024	8	15	2	2		CH33-31B	8	7	0	0		CBX40UHV-060	9	8	1	3		
	CBX32MV-024/030	12	18	1	15		CR33-48B/C	9	6	0	8		CH33-50/60C	9	7	1	6		
	CBX32MV-036	11	22	1	6		CX34-38A/B	8	16	1	2		CH33-60D	7	6	0	11		
	CBX40UHV-024	11	22	1	6		CX34-44/48B/C	8	19	1	6		CR33-50/60C	7	6	0	12		
	CH33-25B	11	13	0	15		CBX26UH-042	11	7	1	1		CR33-60D	7	6	0	12		
	CH33-36B	11	13	0	15		CBX27UH-042	8	23	2	11		CX34-49C	6	7	0	0		
CR33-30/36A/B/C	11	6	0	0	CBX27UH-048	8	23	2	11	CX34-60D	9	5	0	0					
-030	CX34-25A/B	12	16	1	9	-042	CBX32M-048	8	23	2	11	-060	CBX26UH-060	6	8	1	11		
	CBX26UH-030	9	16	0	14		CBX32MV-036	7	8	0	0		CBX27UH-060	6	8	2	1		
	CBX27UH-030	9	22	1	0		CBX32MV-048	8	23	2	11		CBX32MV-060	6	7	0	15		
	CBX32M-036	9	22	1	0		CBX40UHV-042	8	23	2	11		CBX32MV-068	8	11	2	2		
	CBX32MV-024/030	9	18	3	3		CBX40UHV-048	8	23	2	11		CBX40UHV-060	6	7	0	15		
	CBX32MV-036	9	22	1	0		CBX40UHV-036	7	8	0	0		CH33-62D	7	11	2	1		
	CBX40UHV-024	9	22	1	0		CH33-43C	7	14	1	2		CR33-60D	10	6	1	6		
	CBX40UHV-030	9	22	1	0								CX34-62C	7	8	1	6		
													CX34-62D	7	7	0	0		

*Amount of charge required in addition to charge shown on unit nameplate.

Table 4. Normal Operating Pressures - Liquid +10 and Vapor +5 PSIG

⚠ IMPORTANT																
Use table 4 as a general guide when performing maintenance checks. This is not a procedure for charging the unit (Refer to Charging / Checking Charge section). Minor variations in these pressures may be expected due to differences in installations. Significant differences could mean that the system is not properly charged or that a problem exists with some component in the system.																
Vapor Line Pressures																
Model Number	Heating Mode					Cooling Mode										
	20 (-7)	30 (-1)	40 (4.5)	50 (10)	60 (16)	65 (18)	70 (21)	75 (24)	80 (27)	85 (29)	90 (32)	95 (35)	100 (38)	105 (41)	110 (43)	115 (45)
13HPX-018	66	80	96	116	136	136	138	138	138	139	140	141	142	144	145	147
13HPX-024	65	79	93	112	134	138	139	139	140	141	143	144	145	144	145	146
13HPX-030	58	73	88	103	119	139	140	141	141	142	143	144	145	146	147	147
13HPX-036	78	87	98	110	128	133	134	134	136	136	137	138	138	139	139	140
13HPX-042	60	75	89	108	125	135	136	137	138	139	140	141	142	143	145	146
13HPX-048	59	71	84	92	95	135	136	137	138	139	140	142	142	143	144	147
13HPX-060	63	76	88	101	113	131	132	133	134	135	136	137	138	139	140	142

*Temperature of the air entering the outside coil.

Liquid Line Pressures																
Model Number	Heating Mode					Cooling Mode										
	20 (-7)	30 (-1)	40 (4.5)	50 (10)	60 (16)	65 (18)	70 (21)	75 (24)	80 (27)	85 (29)	90 (32)	95 (35)	100 (38)	105 (41)	110 (43)	115 (45)
13HPX-018	275	289	305	323	340	236	252	272	294	316	339	363	389	415	443	472
13HPX-024	267	283	299	316	334	251	271	293	315	337	361	386	413	441	471	502
13HPX-030	267	279	292	305	317	259	283	307	331	355	379	403	427	451	475	499
13HPX-036	289	309	301	335	353	264	284	305	327	350	372	399	425	452	480	510
13HPX-042	275	288	299	313	324	238	258	280	303	325	350	375	402	430	459	490
13HPX-048	274	286	299	309	316	245	265	285	307	330	354	381	409	438	469	505
13HPX-060	275	287	293	326	339	259	272	294	315	343	366	388	416	443	474	494

*Temperature of the air entering the outside coil.

Table 5. HFC-410A Temperature — Pressure (Psig)

°F	°C	Psig	°F	°C	Psig
-40	-40.0	11.6	60	15.6	170
-35	-37.2	14.9	65	18.3	185
-30	-34.4	18.5	70	21.1	201
-25	-31.7	22.5	75	23.9	217
-20	-28.9	26.9	80	26.7	235
-15	-26.1	31.7	85	29.4	254
-10	-23.3	36.8	90	32.2	274
-5	-20.6	42.5	95	35.0	295
0	-17.8	48.6	100	37.8	317
5	-15.0	55.2	105	40.6	340
10	-12.2	62.3	110	43.3	365
15	-9.4	70.0	115	46.1	391
20	-6.7	78.3	120	48.9	418
25	-3.9	87.3	125	51.7	446
30	-1.1	96.8	130	54.4	476
35	1.7	107	135	57.2	507
40	4.4	118	140	60.0	539
45	7.2	130	145	62.8	573
50	10.0	142	150	65.6	608
55	12.8	155			

System Operation

UNIT COMPONENTS

⚠ IMPORTANT

Some scroll compressor have internal vacuum protector that will unload scrolls when suction pressure goes below 20 psig. A hissing sound will be heard when the compressor is running unloaded. Protector will reset when low pressure in system is raised above 40 psig. **DO NOT REPLACE COMPRESSOR.**

The outdoor unit and indoor blower cycle on demand from the room thermostat. If the thermostat blower switch is in the **ON** position, the indoor blower operates continuously.

Bi-Flow Liquid line Filter Drier

The unit is equipped with a large-capacity bi-flow filter drier which keeps the system clean and dry. If replacement is necessary, order another of the same design and capacity. The replacement filter drier must be suitable for use with HFC-410A refrigerant.

Low Pressure Switch (S87)

The 13HPX is equipped with an auto-reset low pressure switch which is located on the vapor line. The switch shuts off the compressor when the vapor pressure falls below the factory setting. This switch, which is ignored during defrost operation, closes at pressures at or above 40 ± 5 psig (276 ± 34 kPa) and opens at 25 ± 5 psig (172 ± 34 kPa). It is not adjustable.

Low Pressure Switch Bypass (S41) (Optional)

For use in applications where the heat pump is operated in outdoor ambient temperatures below 15°F.

- Prevents nuisance trips from the low pressure switch
- Wired in parallel with the low pressure switch

High Pressure Switch (S4)

The 13HPX is equipped with an auto-reset high pressure switch (single-pole, single-throw) which is located on the liquid line. The switch shuts off the compressor when discharge pressure rises above the factory setting. The switch is normally closed and is permanently adjusted to trip (open) at 590 ± 15 psig (4068 ± 103 kPa).

NOTE — A Schrader core is under the pressure switches.

Defrost Thermostat (S6)

The defrost thermostat is located on the liquid line between the check/expansion valve and the distributor. When defrost thermostat senses 42°F (5.5°C) or cooler, the thermostat contacts close and send a signal to the defrost control to start the defrost timing. It also terminates defrost when the liquid line warms up to 70°F (21°C).

Crankcase Heater (HR1) and Thermostat Switch (S40) (-60 model only)

All models sizes are equipped with a belly band type crankcase heater. HR1 prevents liquid from accumulating in the compressor. The HR1 is controlled by a single pole, single throw thermostat switch (S40) located on the liquid line (see figure 1 for location). On all other units, the heater is on when there is no compressor operation.

Thermal Protection Switch (S173) — Compressor Mounted

Some XC13 units are equipped with a compressor mounted normally closed temperature switch that prevents compressor damage due to overheating caused by internal friction. The switch is located on top of the compressor casing (see figure 1). This switch senses the compressor casing temperature and opens at 239-257°F (115°C-125°C) to shut off compressor operation. The auto-reset switch closes when the compressor casing temperature falls to 151-187°F (66°C-86°C), and the compressor is re-energized. This single-pole, single-throw (SPST) bi-metallic switch is wired in series with the 24V Y input signal to control compressor operation.

Defrost System

The defrost system includes a defrost thermostat (S6) and a defrost control (CMC1).

DEFROST CONTROL (CMC1)

This defrost control includes the combined functions of a time/temperature defrost control, defrost relay, time delay, diagnostic LEDs, and a terminal strip for field wiring connections.

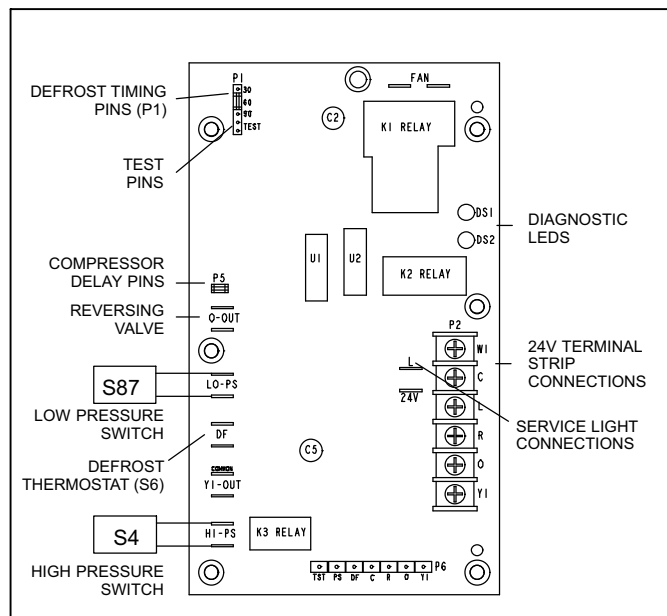

Figure 24. Defrost Control (CMC1)

The defrost control provides automatic switching from normal heating operation to defrost mode and back. When the defrost thermostat is closed, the control accumulates compressor run time at 30, 60 or 90 minute field adjustable intervals. When the selected compressor run time interval is reached, the defrost relay is energized and defrost begins.

Defrost Control Timing Pins (P1)

Each timing pin selection provides a different accumulated compressor run time period for one defrost cycle. This time period must occur before a defrost cycle is initiated. The defrost interval can be adjusted to 30 (T1), 60 (T2), or 90 (T3) minutes (see figure 24). The maximum defrost period is 14 minutes and cannot be adjusted.

NOTE — Defrost control part number is listed near the **P1** timing pins.

- Units with defrost control **100269-02**: Factory default is 60 minutes
- Units with defrost control **100269-04**: Factory default is 90 minutes

If the timing selector jumper is missing, the defrost control defaults to a 90-minute defrost interval.

Compressor Delay (P5)

The defrost control has a field-selectable function to reduce occasional sounds that may occur while the unit is cycling in and out of the defrost mode.

- Units with defrost control **100269-02**: The compressor will be cycled off for 30 seconds going in and out of the defrost mode when the compressor delay jumper is removed.
- Units with defrost control **100269-04**: The compressor will be cycled off for 30 seconds going in and out of the defrost mode when the compressor delay jumper is installed.

NOTE — The 30-second compressor feature is ignored when jumpering the TEST pins.

Time Delay

The timed-off delay is five minutes long. The delay helps to protect the compressor from short-cycling in case the power to the unit is interrupted or a pressure switch opens. The delay is bypassed by placing the timer select jumper across the TEST pins for 0.5 seconds.

Test Mode (P1)

A TEST option is provided for troubleshooting. **The TEST mode may be started any time the unit is in the heating mode and the defrost thermostat is closed or jumpered.** If the jumper is in the TEST position at power-up, the defrost control will ignore the test pins. When the jumper is placed across the TEST pins for two seconds, the defrost control will enter the defrost mode. If the jumper is removed before an additional 5-second period has elapsed (7 seconds total), the unit will remain in defrost mode until the defrost thermostat opens or 14 minutes have passed. If the jumper is not removed until after the additional 5-second period has elapsed, the defrost will terminate and the test option will not function again until the jumper is removed and re-applied.

Service Light Connection

The defrost control includes terminal connections for a service light which provides a signal that activates the room thermostat service light during periods of inefficient operation.

Defrost Control Diagnostic LEDs

The defrost board uses two LEDs for diagnostics. The LEDs flash a specific sequence according to the condition.

Table 6. Defrost Control (CMC1) Diagnostic LEDs

Mode	Green LED (DS2)	Red LED (DS1)
No power to control	OFF	OFF
Normal operation / power to control	Simultaneous Slow FLASH	
Anti-short cycle lockout	Alternating Slow FLASH	
High pressure switch fault	Slow FLASH	OFF
High pressure switch lockout	ON	OFF

Maintenance

Outdoor Unit

1. Clean and inspect outdoor coil (may be flushed with a water hose). Ensure power is off before cleaning.
2. Outdoor unit fan motor is pre-lubricated and sealed. No further lubrication is needed.
3. Visually inspect all connecting lines, joints and coils for evidence of oil leaks.
4. Check all wiring for loose connections.
5. Check for correct voltage at unit (unit operating).
6. Check amp draw on outdoor fan motor.

Motor Nameplate: _____ **Actual:** _____.

7. Inspect drain holes in coil compartment base and clean if necessary.

NOTE - If insufficient heating or cooling occurs, the unit should be gauged and refrigerant charge should be checked.

Outdoor Coil

It may be necessary to flush the outdoor coil more frequently if it is exposed to substances which are corrosive or which block airflow across the coil (e.g., pet urine, cottonwood seeds, fertilizers, fluids that may contain high levels of corrosive chemicals such as salts)

- Outdoor Coil — The outdoor coil may be flushed with a water hose.
- Outdoor Coil (Sea Coast) — Moist air in ocean locations can carry salt, which is corrosive to most metal. Units that are located near the ocean require frequent inspections and maintenance. These inspections will determine the necessary need to wash the unit including the outdoor coil. Consult your installing contractor for proper intervals/procedures for your geographic area or service contract.

Indoor Unit

1. Clean or change filters.
2. Lennox blower motors are prelubricated and permanently sealed. No more lubrication is needed.
3. Adjust blower speed for cooling. Measure the pressure drop over the coil to determine the correct blower CFM. Refer to the unit information service manual for pressure drop tables and procedure.
4. *Belt Drive Blowers* - Check belt for wear and proper tension.

5. Check all wiring for loose connections.
6. Check for correct voltage at unit. (blower operating)
7. Check amp draw on blower motor.

Motor Nameplate: _____ **Actual:** _____.

Indoor Coil

1. Clean coil if necessary.
2. Check connecting lines, joints and coil for evidence of oil leaks.
3. Check condensate line and clean if necessary.

HOMEOWNER

Cleaning of the outdoor unit's coil should be performed by a trained service technician. Contact your dealer and set up a schedule (preferably twice a year, but at least once a year) to inspect and service your outdoor unit. The following maintenance may be performed by the homeowner.

CAUTION

Physical contact with metal edges and corners while applying excessive force or rapid motion can result in personal injury. Be aware of, and use caution when working near these areas during installation or while servicing this equipment.

IMPORTANT

Sprinklers and soaker hoses should not be installed where they could cause prolonged exposure to the outdoor unit by treated water. Prolonged exposure of the unit to treated water (i.e., sprinkler systems, soakers, waste water, etc.) will corrode the surface of steel and aluminum parts and diminish performance and longevity of the unit.

Outdoor Coil

The outdoor unit must be properly maintained to ensure its proper operation.

- Please contact your dealer to schedule proper inspection and maintenance for your equipment.
- Make sure no obstructions restrict airflow to the outdoor unit.
- Grass clippings, leaves, or shrubs crowding the unit can cause the unit to work harder and use more energy.
- Keep shrubbery trimmed away from the unit and periodically check for debris which collects around the unit.

Routine Maintenance

In order to ensure peak performance, your system must be properly maintained. Clogged filters and blocked airflow prevent your unit from operating at its most efficient level.

1. **Air Filter** — Ask your Lennox dealer to show you where your indoor unit's filter is located. It will be either at the indoor unit (installed internal or external to the cabinet) or behind a return air grille in the wall or

ceiling. Check the filter monthly and clean or replace it as needed.

2. **Disposable Filter** — Disposable filters should be replaced with a filter of the same type and size.

NOTE — If you are unsure about the filter required for your system, call your Lennox dealer for assistance.

3. **Reusable Filter** — Many indoor units are equipped with reusable foam filters. Clean foam filters with a mild soap and water solution; rinse thoroughly; allow filter to dry completely before returning it to the unit or grille.

NOTE — The filter and all access panels must be in place any time the unit is in operation.

4. **Indoor Unit** — The indoor unit's evaporator coil is equipped with a drain pan to collect condensate formed as your system removes humidity from the inside air. Have your dealer show you the location of the drain line and how to check for obstructions. (This would also apply to an auxiliary drain, if installed.)

Thermostat Operation

See the thermostat homeowner manual for instructions on how to operate your thermostat.

Heat Pump Operation

Your new Lennox heat pump has several characteristics that you should be aware of:

- Heat pumps satisfy heating demand by delivering large amounts of *warm* air into the living space. This is quite different from gas- or oil-fired furnaces or an electric furnace which deliver lower volumes of considerably *hotter* air to heat the space.
- Do not be alarmed if you notice frost on the outdoor coil in the winter months. Frost develops on the outdoor coil during the heating cycle when temperatures are below 45°F (7°C). An electronic control activates a defrost cycle lasting 5 to 15 minutes at preset intervals to clear the outdoor coil of the frost.
- During the defrost cycle, you may notice steam rising from the outdoor unit. This is a normal occurrence. The thermostat may engage auxiliary heat during the defrost cycle to satisfy a heating demand; however, the unit will return to normal operation at the conclusion of the defrost cycle.

Extended Power Outage

The heat pump is equipped with a compressor crankcase heater which protects the compressor from refrigerant *slugging* during cold weather operation.

If power to your unit has been interrupted for several hours or more, set the room thermostat selector to the EMERGENCY HEAT setting to obtain temporary heat without the risk of serious damage to the heat pump.

In EMERGENCY HEAT mode, all heating demand is satisfied by auxiliary heat; heat pump operation is locked out. After a six-hour compressor crankcase warm-up period, the thermostat can be switched to the HEAT setting and normal heat pump operation may resume.

Preservice Check

If your system fails to operate, check the following before calling for service:

- Verify room thermostat settings are correct.
- Verify that all electrical disconnect switches are ON.
- Check for any blown fuses or tripped circuit breakers.
- Verify unit access panels are in place.
- Verify air filter is clean.
- If service is needed, locate and write down the unit

model number and have it handy before calling.

Accessories

For update-to-date information, see any of the following publications:

- Lennox 13HPX Engineering Handbook
- Lennox Product Catalog
- Lennox Price Book

Start-Up and Performance Checklist		
Job Name _____	Job no. _____	Date _____
Job Location _____	City _____	State _____
Installer _____	City _____	State _____
Unit Model No. _____	Serial No. _____	Service Technician _____
Nameplate Voltage _____		
Rated Load Ampacity _____	Compressor _____	Outdoor Fan _____
Maximum Fuse or Circuit Breaker _____		
Electrical Connections Tight? <input type="checkbox"/>	Indoor Filter clean? <input type="checkbox"/>	Supply Voltage (Unit Off) _____
Indoor Blower RPM _____	S.P. Drop Over Indoor (Dry) _____	Outdoor Coil Entering Air Temp. _____
Discharge Pressure _____	Vapor Pressure _____	Refrigerant Charge Checked? <input type="checkbox"/>
Refrigerant Lines: - Leak Checked? <input type="checkbox"/>	Properly Insulated? <input type="checkbox"/>	Outdoor Fan Checked? <input type="checkbox"/>
Service Valves: --- Fully Opened? <input type="checkbox"/>	Caps Tight? <input type="checkbox"/>	Thermostat
Voltage With Compressor Operating _____	Calibrated? <input type="checkbox"/>	Properly Set? <input type="checkbox"/> Level? <input type="checkbox"/>