



ENGINEERING DATA

FEATURES

WARRANTY

All covered components - limited warranty for five years in residential applications, one year in non-residential applications.

Refer to the Lennox Equipment Limited Warranty certificate included with the unit for additional details.

APPROVALS

Units are UL listed per ANSI/UL 998 and CSA C22.2 No.104-01.

APPLICATIONS

Applicable to most forced air installations.

Installs on the supply air plenum with a by-pass duct from the return plenum in up-flow and horizontal applications. Installs on the return air plenum with a by-pass duct from the supply plenum in down-flow applications. See Typical Applications.

Provides additional humidity to the home during the heating season to increase comfort level.

Do not install where freezing may occur.

Humidifier, saddle valve and manual or automatic humidifier control (depending on model) shipped in one package.

SEQUENCE OF OPERATION

Humidifier will only operate when indoor blower is operating.

When the level of moisture in the return air or living space area drops below the set point of the humidifier control, the water solenoid valve opens, water flows into distribution tray and weeps down through the evaporator pad. By-pass air flows over the evaporator pad, increasing the humidity of the air, and then back into the return air stream. When the humidifier control is satisfied the water solenoid valve closes.

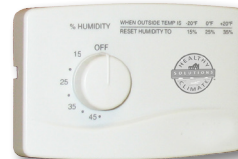

Manual Humidistat
(furnished with standard Models)



Automatic Humidifier Control
(furnished with "A" Models)

CABINET

Rugged, corrosion resistant molded plastic. Humidifier is shipped for left-hand by-pass duct connection.

For right-hand by-pass duct connection, rotate humidifier cabinet 180° top for bottom and relocate drain spud. See Installation Instructions for additional details.

Built-in damper included to close off bypass duct during summer cooling operation.

MODEL NUMBER IDENTIFICATION

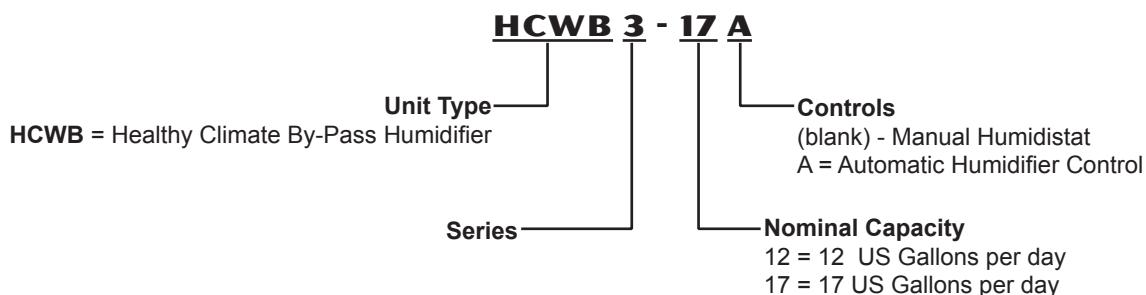

FEATURES

CONTROLS

Manual Humidistat - HCWB3-12 and HCWB3-17

Can be horizontally mounted on wall or duct.

Provides manual control of room relative humidity.

Wired in series with the humidifier water solenoid valve.

Adjustable setting.

Automatic Humidifier Control - HCWB3-12A and HCWB3-17A

Wall or duct mounted.

Automatic or manual mode control. Manual Mode label (with resistor to bypass outdoor temperature sensor) are furnished to indicate when humidistat is installed in Manual Mode.

Senses indoor relative humidity and outdoor temperature. Includes outdoor temperature sensor for use with automatic control option and resistor for manual control setting.

Adjusts humidity setpoint to provide optimum humidity levels within the space.

Adjustable setting.

WATER SUPPLY

Consists of supply tubing, orifice, distribution tray, cleanable/replaceable internal strainer and 24 volt brass water solenoid valve with stainless steel seat.

Drain

1/2 in. drain fitting at bottom of cabinet.

1/2 in. ID plastic tubing must be field provided.

Unused water from the evaporator pad is drained from the unit to help remove mineral deposits left from the evaporative process.

Distribution Tray

Reservoir and unique polyester liner provides even water distribution across the evaporator media pad for optimal performance.

Tray and support frame removable for cleaning or replacement.

Evaporator Media Pad

Provides large evaporation capacity.

Pad and support frame removable for cleaning or replacement.

Annual pad replacement recommended.

Saddle Valve

All necessary fittings furnished as standard equipment.

Field installs in the water supply line

OPTIONAL ACCESSORIES

Installation Kit (Canada Only)

Kit contains: 6 in. dia. duct ring flange, 2.5 ft. of 6 in. dia. galvanized steel flexible duct, 10 ft. of 1/4 in. OD polyethylene water feed tube, 15 ft. of 1/2 in. ID clear nylon drain tube, 10 ft. of 2-conductor 18 AWG thermostat wire, one hose clamp, two plastic compression sleeves, and two plastic compression ferrules.

MAINTENANCE SUPPLIES

Replacement Media

Recommended annual replacement of media pad.

See Specifications table for catalog number.

SPECIFICATIONS

Model No.	With Manual Humidistat Control	HCWB3-12	HCWB3-17
	With Automatic Humidifier Control	HCWB3-12A	HCWB3-17A
Capacity - 120°F plenum temperature, 0.20 in. w.c. static pressure drop		12 US gallons per day	17 US gallons per day
Water Feed Rate (gallons per hour @ 50 PSI water pressure)		3	3
Evaporator pad size - H x W x D - in.		9-1/2 x 9-5/8 x 1-11/16	13 x 10 x 1-11/16
Connections	Plenum H x W - in.	9-1/2 x 9-1/2	12-3/4 x 10
	By-Pass Duct - in.	6 round	6 round
	Water supply	1/4 in. compression	1/4 in. compression
	Drain	1/2 in. I.D.	1/2 in. I.D.
Electrical characteristics		24V	24V
Shipping Data - lbs. (1 package)		8	9
MAINTENANCE SUPPLIES - MUST BE ORDERED EXTRA			
Replacement Media		X2660	X2661
OPTIONAL ACCESSORIES - MUST BE ORDERED EXTRA			
Installation Kit (Canada Only)		21N85	21N85

TYPICAL APPLICATIONS

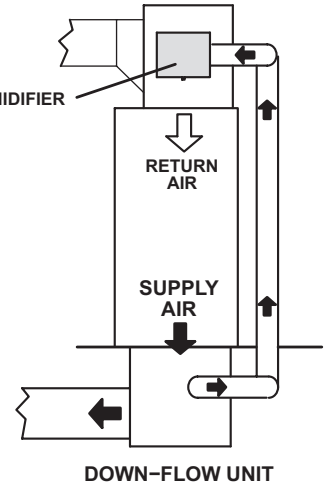
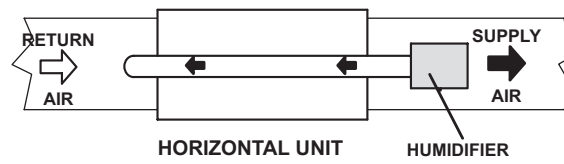
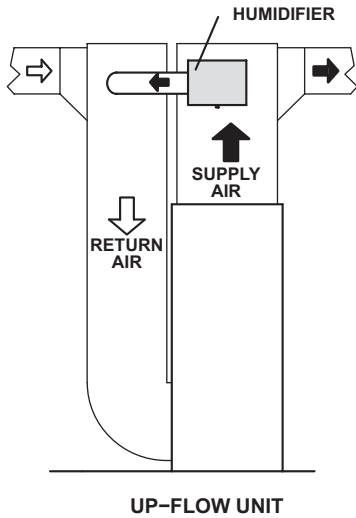

DIMENSIONS - INCHES (MM)

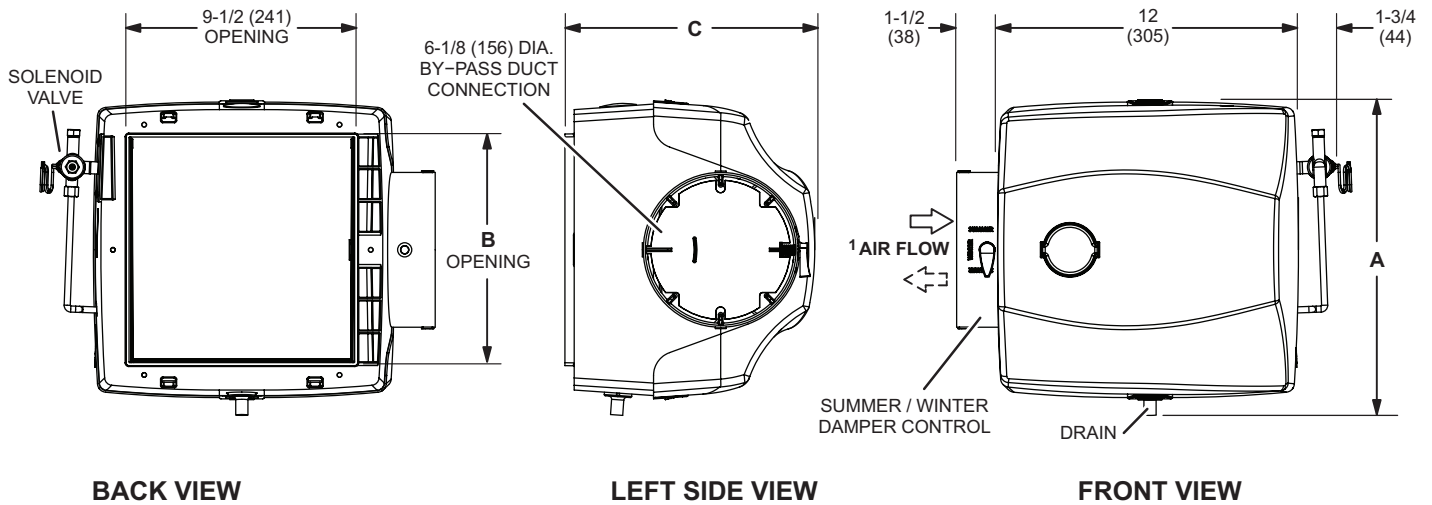

NOTES:

- By-pass duct air flow direction is dependent on application.
- For upflow/horizontal applications air flow is from the humidifier to return air duct.
 - For downflow applications, air-flow is to the humidifier from the supply air duct.

¹ Left hand air inlet/outlet shown. For right-hand inlet/outlet, rotate humidifier cabinet 180° top for bottom and relocate drain to alternate location on cabinet. See Installation Instructions for additional details.

Model No.	A		B		C	
	in.	mm	in.	mm	in.	mm
HCWB3-12(A)	12-7/8	327	9-1/2	241	10-1/4	260
HCWB3-17(A)	15-7/8	403	12-3/4	324	10-1/2	267

HUMIDIFIER SIZING INFORMATION

(BASED ON VOLUME OF HOME)

Model No.	Type of Home	8 Foot Ceiling	9 Foot Ceiling	10 Foot Ceiling
		Home Area (sq. ft.)	Home Area (sq. ft.)	Home Area (sq. ft.)
HCWB3-12, HCWB3-12A	Loose	750	666	600
	Average	1500	1350	1200
	Tight	3000	2700	2400
HCWB3-17, HCWB3-17A	Loose	1000	888	800
	Average	2000	1800	1600
	Tight	4000	3600	3200

NOTES:

Loose Home = Two Air Change Rates per hour: Typically, loose in construction and is over 20 years old. Not very well insulated and may have single pane windows, etc.

Average Home = One Air Change Rate per hour: Average in construction, 15 to 20 years old on average.

Tight Home = One-Half Air Change Rate per hour: Newer home with tight construction..

Also see Healthy Climate Power Humidifier HCWP3 bulletin for additional sizing conditions if needed.



Visit us at www.lennox.com

For the latest technical information, www.lennox.com

Contact us at 1-800-4-LENNOX

NOTE - Due to Lennox' ongoing commitment to quality, Specifications, Ratings and Dimensions subject to change without notice and without incurring liability. Improper installation, adjustment, alteration, service or maintenance can cause property damage or personal injury. Installation and service must be performed by a qualified installer and servicing agency.

©2009 Lennox Industries, Inc.