



## LENNOX' ELITE® SERIES

Home Comfort Systems



### G61

Two-stage, high-efficiency furnace



HOME COMFORT SYSTEMS  
*Innovation never felt so good.™*



# Elite® Series G61 Gas Furnace

Innovation never felt so good.™

Two-stage operation minimizes up-and-down temperature changes

High efficiency can save you hundreds of dollars each year

Low-speed, continuous fan setting provides a quiet, consistent flow of air

ENERGY STAR® qualified

The G61 gas furnace has two levels of heat output for enhanced comfort and efficiency. It's like having two furnaces in one: a small furnace (low heat) for mild days and a larger furnace (high heat) for extremely cold days.

## TWO LEVELS OF HEAT, A HIGH LEVEL OF COMFORT

Unlike typical single-stage models that operate only at full capacity, the G61 can adjust outputs to match household heating demand. More than 80% of the time, it runs at low stage, which means more even heat distribution and quieter operation.

### SPACE TEMPERATURE COMPARISON

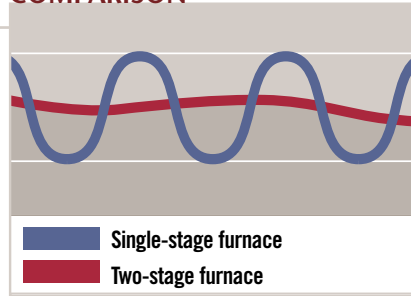

### 3-YEAR HEATING SAVINGS

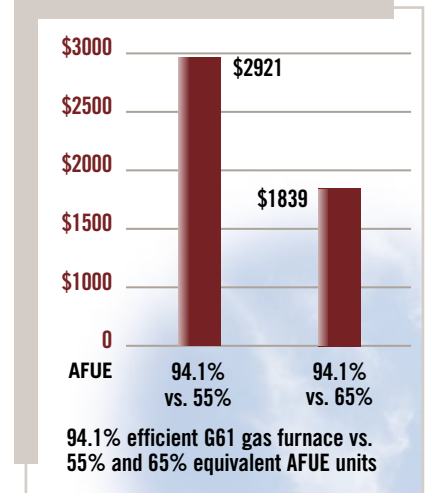

## Efficient More comfort for your energy dollar

With its two-stage design, the G61 not only keeps you warm – it reduces your energy costs. With an efficiency rating of 94.1% AFUE (Annual Fuel Utilization Efficiency), compared with older 55% AFUE units, the G61 can save you up to \$1,000 per year.

This chart depicts potential energy savings you can expect from the G61 gas furnace versus older furnaces with lower efficiency ratings. Criteria used in this example are 2,000 full-load heating hours, with a 60,000-Btuh heating design load and \$1.074 ccf for gas. Your actual savings will vary depending on the weather, local fuel rates and your lifestyle.

Source: U.S. Department of Energy national average energy rates.

### EFFICIENCY RATING

**94.1% AFUE** (Annual Fuel Utilization Efficiency).

### WARRANTY\*

Limited lifetime warranty on the heat exchanger.

5-year limited warranty on all remaining covered components.



For even greater efficiency, the G61 can be paired with an electric heat pump.

Called dual fuel, this combination minimizes heating costs by seamlessly

alternating between the two energy sources, depending on outdoor conditions.

\*Applies to residential applications only. See actual warranty certificate for details.

## INNOVATIVE FEATURES FOR ENHANCED COMFORT AND EFFICIENCY

### Duralok Plus® Heat Exchanger –

Made of high-quality, patented ArmorTuf™ aluminized steel. Life-tested in excess of industry standards for long product life and durability.

### Stainless Steel Secondary Heat Exchanger –

Improves efficiency by capturing additional heat.

**Two-Stage Heating** – Provides two levels of heat output for greater temperature control and comfort.

### Continuous Low-Speed Fan –

Slowly circulates air for improved comfort and air quality.

### SureLight® Control Board –

Ensures reliable and efficient operation.

**SureLight® Igniter** – Nitride design provides long product life and reliable operation.

### Insulated Blower Compartment –

Minimizes operating sounds.

### Durable Steel Cabinet –

Built to last and coated with high-quality, corrosion resistant polyester, textured-paint finish.

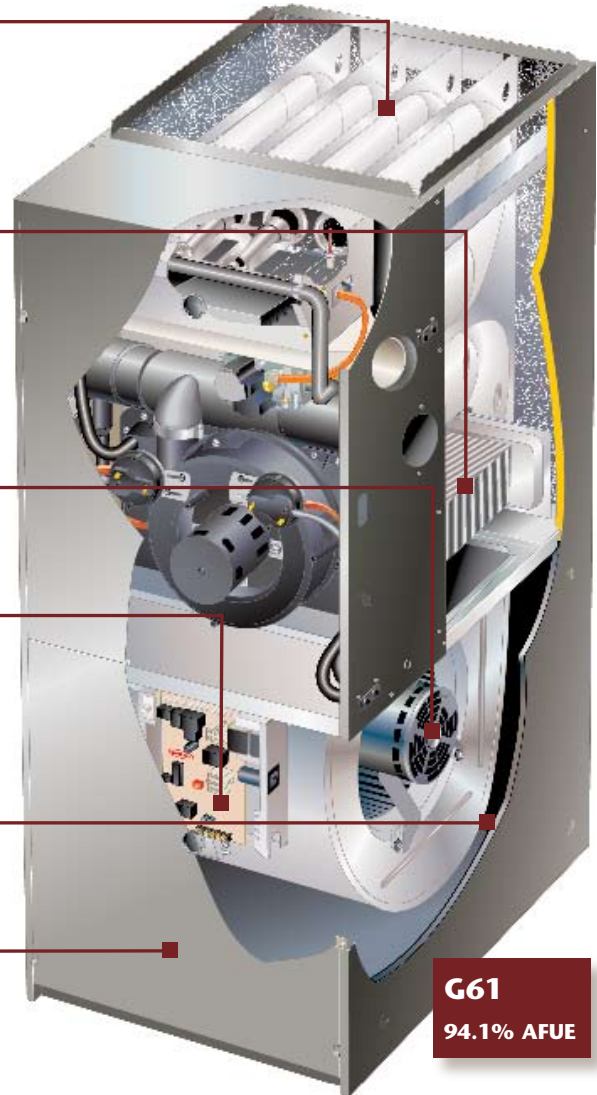

## Elite® Series G61 Specifications

G61	36B-045	36B-070	48C-090	60C-090	48C-110	60C-110	60D-135
AFUE	94.1%	94.1%	94.1%	94.1%	94.1%	94.1%	94.1%
Dimensions							
HxWxD (in.)	40 x 17-1/2 x 28-1/2	40 x 17-1/2 x 28-1/2	40 x 21 x 28-1/2	40 x 21 x 28-1/2	40 x 21 x 28-1/2	40 x 21 x 28-1/2	40 x 24-1/2 x 28-1/2
HxWxD (mm)	1016 x 446 x 724	1016 x 446 x 724	1016 x 533 x 724	1016 x 533 x 724	1016 x 533 x 724	1016 x 533 x 724	1016 x 622 x 724

**Note:** Due to Lennox' ongoing commitment to quality, all specifications, ratings and dimensions are subject to change without notice.

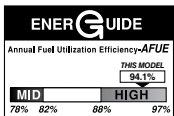

Many Lennox® home comfort systems meet ENERGY STAR® requirements when used with appropriate components. Ask your dealer for details.



Lennox is proud of the fact that these products have earned the Good Housekeeping Seal.



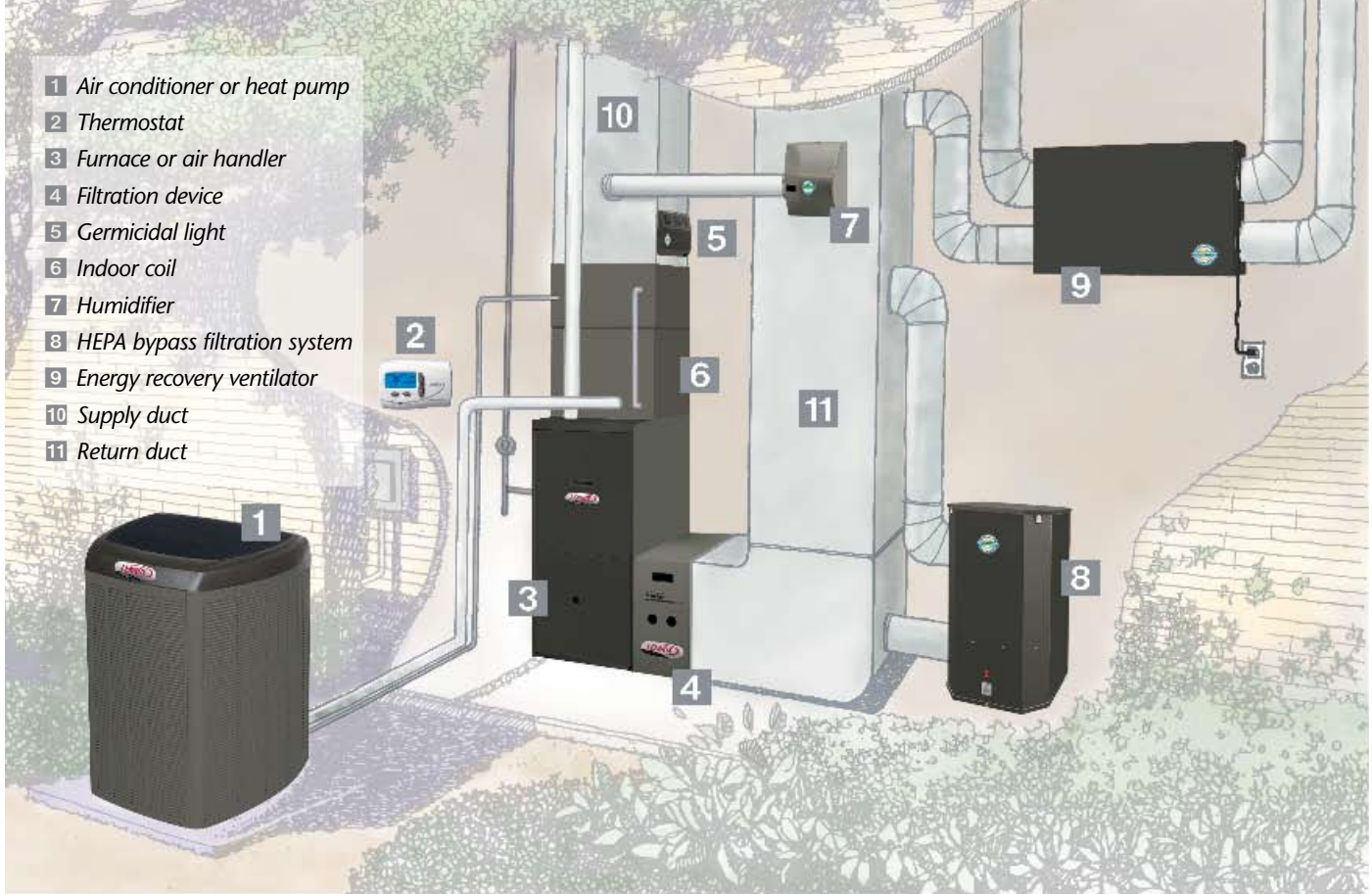

- 1 Air conditioner or heat pump
- 2 Thermostat
- 3 Furnace or air handler
- 4 Filtration device
- 5 Germicidal light
- 6 Indoor coil
- 7 Humidifier
- 8 HEPA bypass filtration system
- 9 Energy recovery ventilator
- 10 Supply duct
- 11 Return duct

## CUSTOMIZE YOUR COMFORT

Lennox® heating, cooling and Healthy Climate® indoor air quality products are designed to provide efficient, economical comfort—not only as individual units, but also together as an integrated system. This combined network of products delivers on every comfort count, from consistent temperatures and balanced humidity to improved indoor air quality.

## DEALERS YOU CAN COUNT ON

Choosing the right dealer for your home's heating, cooling and air quality needs is every bit as important as choosing the right brand. We think you'll agree our independent dealers are a big reason you can count on quality customer service whenever you call. Your Lennox dealer's dedication to quality shows in his knowledge, training and expertise in designing the right system for your home, installing it properly and keeping it running perfectly for many years to come.



**LENNOX**

HOME COMFORT SYSTEMS  
*Innovation never felt so good.™*

© Lennox Industries Inc. 2002

Visit us at [www.lennox.com](http://www.lennox.com), or contact us at 1-800-9-LENNOX.