



**RETAIN THESE INSTRUCTIONS
 FOR FUTURE REFERENCE**

⚠ IMPORTANT

**The O23V series unit must be serviced annually.
 All service must be performed by a qualified service technician.**

O23V SERIES UNITS ARE NOT FOR USE IN ZONING APPLICATIONS!

General

These instructions are intended as a general guide and do not supersede local codes in any way. Only qualified technicians can install and service the Dave Lennox Signature™ Collection O23V oil furnaces. In Canada, refer to CSA B139 for recommended installation procedures. Consult authorities who have jurisdiction before installation.

Shipping & Packing List

- 1 - Assembled oil furnace
- 1 - Barometric draft control
- 1 - Side exhaust pipe collar
- 1 - Direct intake collar (AFII burner units only)

Check the components for shipping damage. If you find any damage, immediately contact the last carrier.

INSTALLATION INSTRUCTIONS

O23V Series Units

OIL UNITS
 505,082M
 10/05

TP Technical
 Publications
 Litho U.S.A.

Table of Contents

General	1
Shipping & Packing List	1
O23V Unit Dimensions	2
O23V Unit Parts Arrangement	3
O23V Oil Burner Parts Arrangement	3
Requirements	4
Locate & Level the Unit	4
Unit Adjustments	5
Venting	5
Flue Connections	10
Supply & Return Air Plenums	10
Oil Supply Lines Sizing	10
Oil Supply Line & Filter Connections	12
Leak Check	12
Electrical	12
Blower Control	13
Unit Start-Up & Adjustments	17
Service	18
Heating Events Actions & Responses	18
Troubleshooting	19
Oil Furnace Start-Up & Check List	24

⚠ WARNING

Do not store or use gasoline or other flammable vapors and liquids in the vicinity of this or any other appliance.

⚠ WARNING

This product contains fiberglass wool. Disturbing the insulation during installation, maintenance, or repair will expose you to fiberglass wool dust. Breathing this may cause lung cancer. (Fiberglass wool is known to the State of California to cause cancer.)

Fiberglass wool may also cause respiratory, skin, and eye irritation.

To reduce exposure to this substance or for further information, consult material safety data sheets available from address shown below, or contact your supervisor.

**Lennox Industries Inc.
 P.O. Box 799900
 Dallas, TX 75379-9900**



O23V Unit Dimensions - Inches (mm)

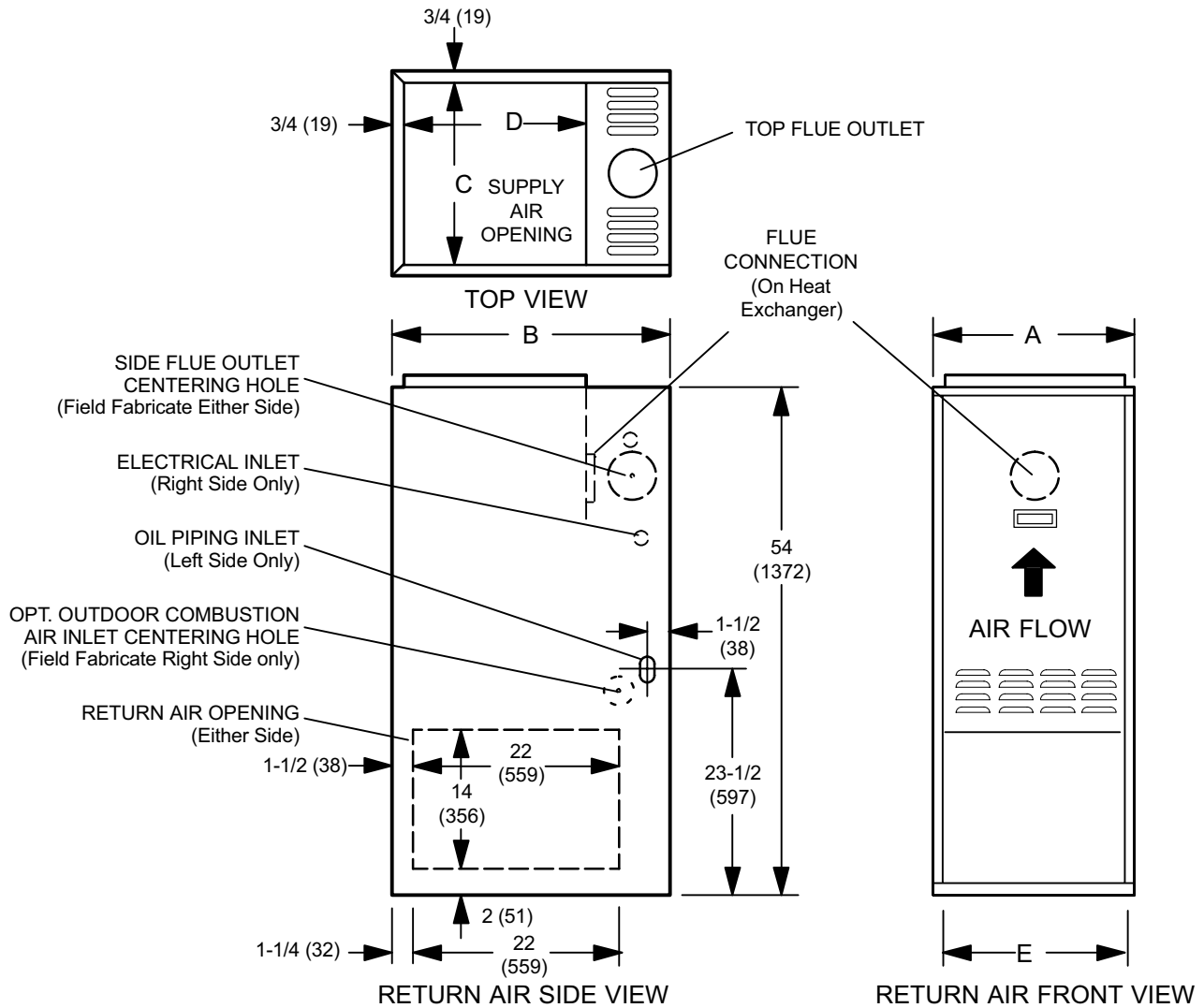

Figure 1

O23V Unit Dimensions - Inches (mm)

O23V Model	A	B	C	D	E
-Q2/3-70/90 & - Q3/4-105/120	19-1/2 (495)	30-5/8 (778)	18 (457)	19-5/8 (498)	16 (406)
-Q5-140/154	22-1/2 (572)	33-1/8 (841)	21 (533)	22-1/8 (562)	18 (457)

⚠ WARNING

Improper installation, adjustment, alteration, service or maintenance can cause personal injury, loss of life, or damage to property.

Installation and service must be performed by a qualified installer or service agency.

⚠ CAUTION

Never burn garbage or paper in the heating system. Never leave papers near or around the unit.

O23V Unit Parts Arrangement

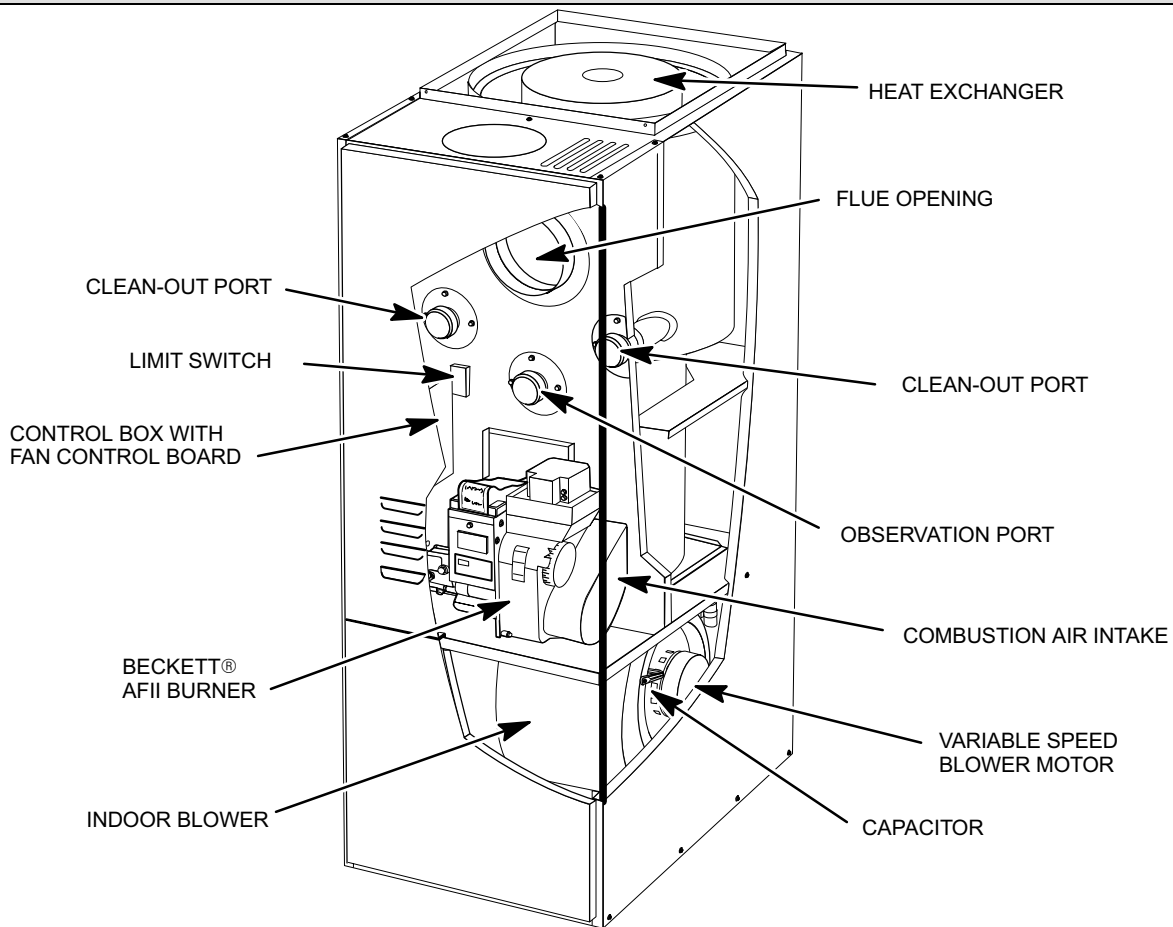

Figure 2

O23V Oil Burner Parts Arrangement

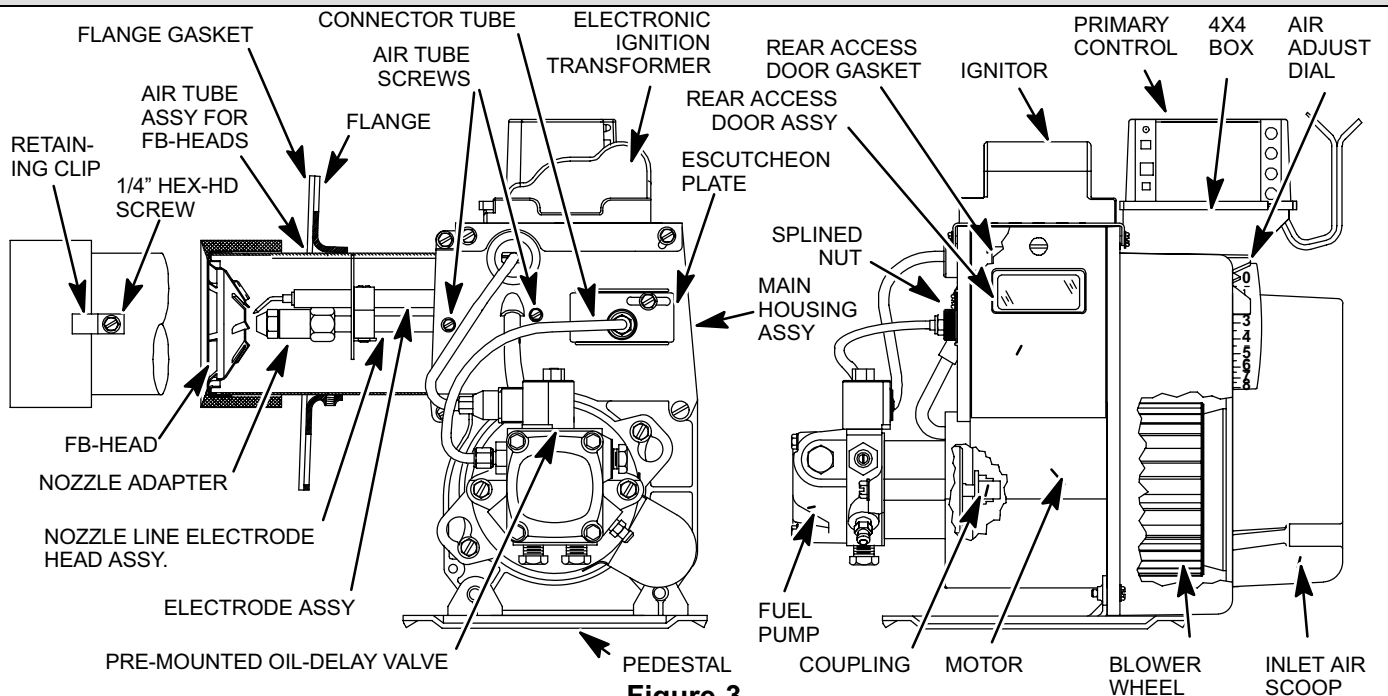

Figure 3

Requirements

CAUTION

When venting this appliance, keep vent terminal free of snow, ice and debris.

CAUTION

Physical contact with metal edges and corners while applying excessive force or rapid motion can result in personal injury. Be aware of, and use caution when working near these areas during installation or while servicing this equipment.

- Installation of Lennox oil-fired furnaces must conform with the National Fire Protection Association Standard for the Installation of Oil Burning Equipment, NFPA No. 31, the National Electrical Code, ANSI/NFPA No.70 (in the U.S.A.), CSA Standard CAN/CSA-B139 (in Canada), Installation Code for Oil Burning Equipment, the Canadian Electrical Code Part1, CSA 22.1 (Canada), the recommendations of the National Environmental Systems Contractors Association and any state or provincial laws or local ordinances. Authorities having jurisdiction should be consulted before installation. Such applicable regulations or requirements take precedence over general instructions in this manual.
- Chimneys and chimney connectors must be of the type and construction outlined in section 160 of NFPA No. 31.
- Air for combustion and ventilation must conform to standards outlined in section 140 of NFPA No. 31 or, in Canada, CSA Standard B139. When installing O23V units in confined spaces such as utility rooms, two combustion air openings are required. Dimensions of combustion air openings are shown in table 1. One opening shall be below burner level and the other opening shall be no more than 6”(152 mm) from the room’s ceiling.

Table 1

Combustion Air Opening Dimensions	
Model No.	(2 openings required)
O23V-70/90/105/120	10” X 20” (254 mm X 508 mm)
O23V-140/154	11” X 22” (279 mm X 559 mm)

- This unit is approved for use on combustible flooring and for clearances to combustible material as listed on unit rating plate and in table 2. Unit service and accessibility clearances take precedence over fire protection clearances.

IMPORTANT

An opening to the outside for combustion air is strongly recommended, especially in new homes. Refer to table 1 or the unit rating plate for specific combustion air opening dimensions.

- The combustion air opening should provide a minimum free area one-half square inch per 1,000 Btu per hour input. This combustion air should be brought into the area containing the furnace below the level of the furnace burner.

Table 2

O23V Installation Clearances	
Clearances	inches (mm)
top of plenum & duct	2 (51)
plenum sides	3 (76)
sides	0 (0)
rear	0 (0)
front	4 (120)
flue pipe	6 (152)

- With the HEAT selector pin in the position shown in the wiring diagram (on page 16), the unit must operate at a temperature rise in the range listed in table 7 (on page 17).
- When installed, furnace must be electrically grounded in accordance with local codes or, in the absence of local codes, with the current National Electric Code, ANSI/NFPA No. 70, or Canadian Electric Code (CEC) if an external electrical source is utilized.
- Field wiring connections with the unit must meet or exceed specifications of type T wire and must withstand a 63°F (17°C) temperature rise.
- If installing a programmable thermostat, use a type which retains its memory in event of a power loss.
- When the furnace is used in conjunction with cooling units, it shall be installed in parallel with, or on the upstream side of, cooling units to avoid condensation in the heating element. With a parallel flow arrangement, a damper (or other means to control the flow of air) shall be adequate to prevent chilled air from entering the furnace and, if manually operated, must be equipped with means to prevent operation of either unit, unless damper is in the full “heat” or “cool” position.

WARNING

When an air conditioning unit is used in conjunction with the furnace, the evaporator coil must be installed in the discharge (supply) air. Do not install an evaporator coil in the return air; excessive condensation will occur within the furnace.

Locate & Level the Unit

Set the unit in desired location keeping in mind the clearances listed in table 2. Also keep in mind oil supply connections, electrical supply, flue connections and sufficient clearance for installing and servicing unit.

Level the unit from side to side and from front to rear. If the furnace is not level, place fireproof wedges or shims between the low side of the furnace and the floor. Make sure the weight of the furnace is distributed evenly on all four corners. Strain on sides of cabinet causing cracking and popping noises may occur if weight of furnace is not evenly distributed.

Unit Adjustments

Neither the nozzle setting nor the air adjustments are factory set. The furnace is fire tested and the limit control is checked to make sure it functions properly; no factory settings are made. During installation, the furnace must be "set up." The installing dealer/contractor must have and use proper test equipment in order to correctly set up the oil furnace. Proper testing equipment is required to ensure correct operation of the unit. The use of test equipment is now more critical than ever due to tighter tolerances needed to keep the furnace operating efficiently.

Among the test equipment for an oil furnace, the proper combustion test kit should contain the following:

- Draft gauge
- CO₂ or O₂ analyzer
- Smoke tester
- Pressure gauge
- High temperature thermometer
- Beckett T-500 gauge
- Oil vacuum gauge
- Knowledge of proper test equipment operation

⚠ CAUTION

Improper nozzle and/or air adjustment of this unit may result in sooting problems. Refer to the following section for correct adjustment procedures.

Adjusting the Nozzle

Proper adjustment of the nozzle assembly is critical because alignment may have changed during shipping. Before the furnace and oil lines are installed, the nozzle assembly must be checked. To check the nozzle assembly, remove the entire burner assembly (not just the nozzle) from the furnace. The lower firing nozzle is factory installed. This should be verified by the installer. Inspect the spark transformer leads also to ensure they are still attached to the electrodes.

The burner assembly is attached to the vestibule panel by three nuts. Slots are provided in the mounting flange for removing the burner assembly from the vestibule. By loosening the nuts and by turning the whole burner assembly counterclockwise (figure 4), the entire burner assembly will come out of the furnace. There is adequate wire to remove the burner without disconnecting wires. Once removed, turn the burner around in the vest panel area.

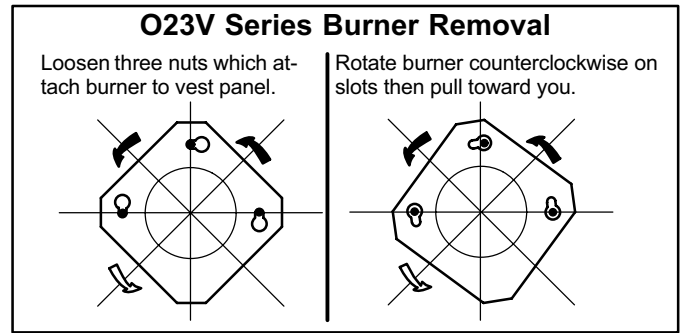

Figure 4

To correctly adjust the nozzle, use a Beckett #T-500 gauge. Insert the small end of the gauge into the end of the cone and measure from the flat of the end cone to the tip of the nozzle. When nozzle depth is correct, the tip of the nozzle should just touch the end of the gauge. Refer to the illustration sheet provided with the gauge. Note that the scale side of the gauge is not used for this purpose. Make corrections by sliding the nozzle assembly forward or backward within the blast tube (figure 5). At the same time, check the nozzle alignment.

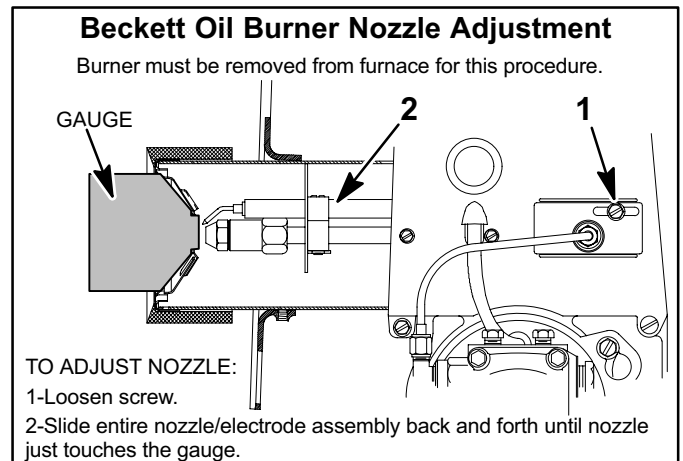

Figure 5

To check nozzle alignment, again insert the small end into the end cone and measure the nozzle and electrode alignment against the center lines marked on the gauge (again refer to enclosed illustration sheet). If the nozzle is not centered, but found to be too far left or right, a new nozzle assembly will need to be ordered. Do not attempt to adjust by bending the 90 degree elbow in the oil line.

Venting

⚠ WARNING

Combustion air openings in front of the furnace must be kept free of obstructions. Any obstruction will cause improper burner operation and may result in a fire hazard.

⚠ WARNING

The barometric damper shall be in the same atmospheric pressure zone as the combustion air inlet to the furnace. Deviation from this practice will cause improper burner operation and may result in a fire hazard.

⚠ WARNING

This furnace is certified for use with type "L" vent. "B" vent must not be used with oil furnaces.

⚠ CAUTION

Do not store combustible materials near the furnace or supply air ducts. The material (such as paint, motor oil, gasoline, paint thinner, etc.) may ignite by spontaneous combustion creating a fire hazard.

NOTE - Oil burning equipment may be vented into an approved masonry chimney or type L vent. (Type L vent is similar in construction to type B gas vent. Type L vent carries a higher temperature rating and is constructed with an inner liner of stainless steel, rather than aluminum.)

Prior to installation of unit, make a thorough inspection of the chimney to determine whether repairs are necessary. Make sure the chimney is properly constructed and sized according to the requirements of the National Fire Protection Association. The smallest dimensions of the chimney should be at least equal to the diameter of the furnace vent connector. Make sure the chimney will produce a steady draft sufficient to remove all the products of combustion from the furnace. A draft of at least .04" w.c. (9.9 Pa) is required during burner operation.

1. Local building codes may have more stringent installation requirements and should be consulted before installation of unit.
2. The vent connector should be as short as possible to do the job.
3. The vent connector should not be smaller than the outlet diameter of the vent outlet of the furnace.
4. Pipe should be at least 24 gauge galvanized.
5. Single wall vent pipe should not run outside or through any unconditioned space.
6. Chimney should extend 3 feet (0.9 m) above highest point where the vent passes through the roof, and 2 feet (0.6 m) higher than any portion of a building within a horizontal distance of 10 feet (3 m).
7. The vent must not pass through a floor or ceiling. Clearances to single wall vent pipe should be no less than 6" (152 mm); more if local codes require it.
8. The vent may pass through a wall where provisions have been made for a thimble as specified in the Standards of the National Board of Fire Underwriters. See figure 6.

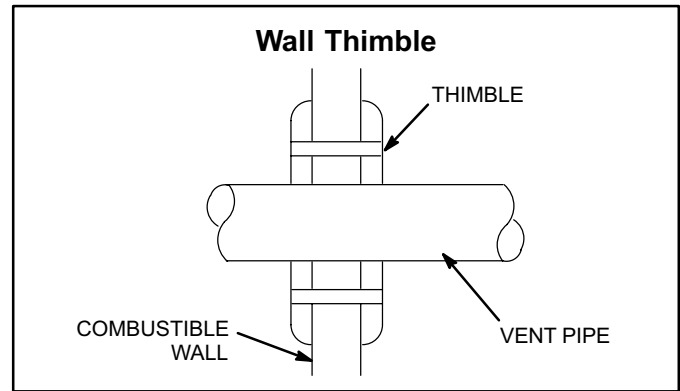

Figure 6

9. The vent pipe should slope upward toward the chimney on horizontal run at least 1/4 inch (6 mm) to the foot (0.3 m) and should be supported by something other than the furnace, such as isolation hangers. See figure 7.

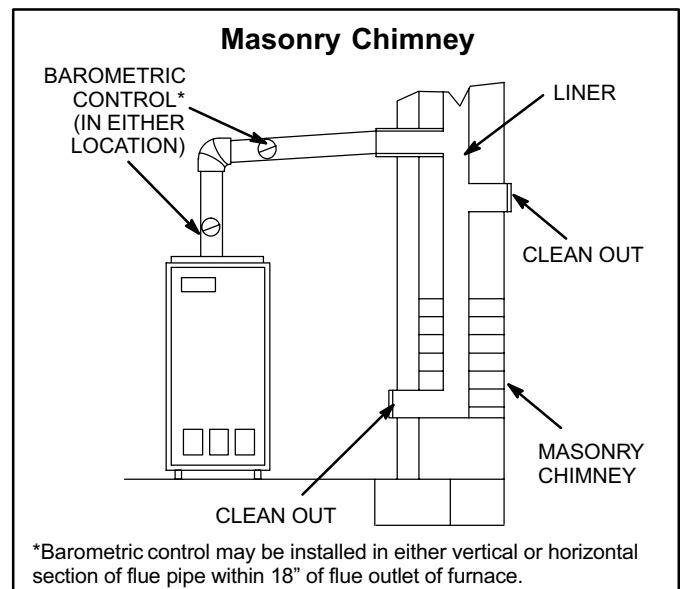

Figure 7

10. Extend the vent pipe into the chimney so that it is flush with the inside of the vent liner. Seal the joint between the pipe and the liner.
11. The furnace shall be connected to a factory built chimney or vent complying with a recognized standard, or masonry or concrete chimney lined with a lining material acceptable to the authority having jurisdiction.
12. When two or more appliances vent into a common vent, the area of the common vent should not be less than the area of the largest vent or vent connection plus 50% of the area of the additional vent or vent connection. Chimney must be able to sufficiently vent all appliances operating at the same time.
13. The vent pipe shall not be connected to a chimney vent serving a solid fuel appliance or any mechanical draft system.
14. All unused chimney openings should be closed.
15. All vent pipe run through unconditioned areas or outside shall be constructed of factory built chimney sections. See figure 8.

16. Where condensation of vent gas is apparent, the vent should be repaired or replaced. Accumulation of condensation in the vent is unacceptable.
17. Vent connectors serving this appliance shall not be connected into any portion of mechanical draft systems operating under positive pressure.
18. Keep the area around the vent terminal free of snow, ice and debris.

NOTE - If vent pipe needs to exit from side of cabinet, use the pilot hole (located on either side of the unit) to cut a 6" (152 mm) round hole. Attach finishing plate (provided) with four sheet metal screws to cover rough edges.

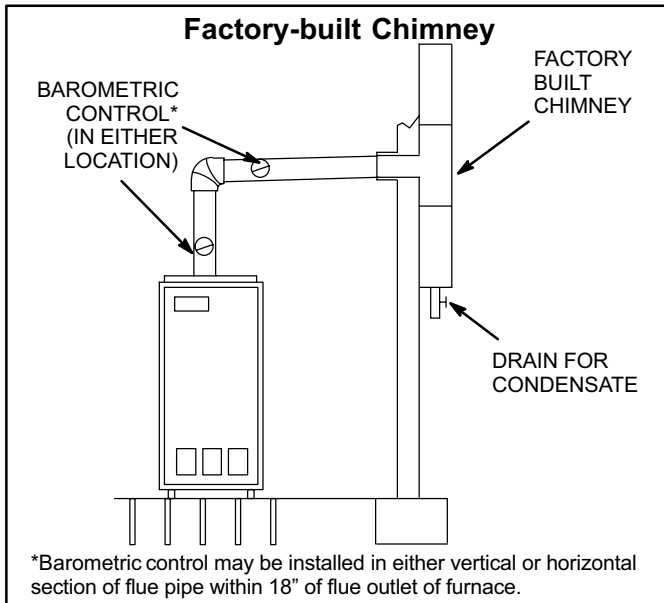

Figure 8

Combustion and Ventilation Air (Confined and Unconfined Spaces)

Homes built with energy conservation in mind use tight construction practices. These houses are sealed so well that it becomes necessary to provide a means of bringing in air from outside for combustion. Also, exhaust fans, appliance vents, chimneys and fireplaces force additional air that could be used for combustion out of the house. Unless outside air is brought into the home for combustion, negative pressure (pressure outside is greater than inside pressure) will build to the point that a down draft can occur in the furnace vent pipe or chimney. Combustion gases enter the living space creating a potentially dangerous situation.

The importance of the previous paragraph cannot be overstated. Users may inadvertently block fresh air intakes after installation.

In the absence of local codes concerning air for combustion and ventilation, the following section outlines guidelines and recommends procedures for operating oil furnaces in a manner that ensures efficient and safe operation. Special consideration must be given to combustion air needs as well as requirements for exhaust vents and oil piping.

Combustion Air Requirements

! WARNING

PERSONAL INJURY OR DEATH! A living space which provides insufficient combustion air to the furnace can result in headaches, nausea, dizziness or asphyxiation.

! CAUTION

Insufficient combustion air to the furnace can cause excess water accumulation in the heat exchanger, resulting in rusting and premature heat exchanger failure. It can also cause property damage.

All oil-fired appliances require air to be used for the combustion process. If sufficient amounts of combustion air are not available, the furnace or other appliance will operate in an inefficient and unsafe manner. Enough air must be provided to meet the needs of all fuel-burning appliances, as well as appliances such as exhaust fans which force air out of the home. When fireplaces, exhaust fans, or clothes dryers are used at the same time as the furnace, much more air is required to ensure proper combustion and to prevent a down-draft situation. Insufficient amounts of air also cause incomplete combustion which can result in sooting. Requirements for providing air for combustion and ventilation depend largely on whether the furnace is installed in an unconfined or confined space.

Unconfined Space

An unconfined space is an area such as a basement or large equipment room with a volume greater than 50 cubic feet (1.4 cubic meters) per 1,000 Btu (293 W) per hour of the combined input rating of all appliances installed in that space. This space also includes adjacent rooms which are not separated by a door. Though an area may appear to be unconfined, it might be necessary to bring in outdoor air for combustion if the structure does not provide enough air by infiltration. If the furnace is located in a building of tight construction with weather stripping and caulking around the windows and doors, follow the procedures outlined for using air from the outside for combustion and ventilation.

Confined Space

A confined space is an area with volume less than 50 cubic feet (1.4 cubic meters) per 1,000 Btu (293 W) per hour of the combined input rating of all appliances installed in that space. This definition includes furnace closets or small equipment rooms.

When the furnace is installed so that supply ducts carry air circulated by the furnace to areas outside the space containing the furnace, the return air must be handled by ducts which are sealed to the furnace casing and which terminate outside the space containing the furnace. This is especially important when the furnace is mounted on a platform in a confined space (e.g., closet or small equipment room). Even a small leak around the base of the unit at the platform or at the return air duct connection can cause a potentially dangerous negative pressure condition. Air for combustion and ventilation can be brought into the confined space either from inside the building or from outside.

Air from an Adjacent Space

If the confined space housing the furnace adjoins space categorized as unconfined, air can be brought in by providing two permanent openings between the two spaces. Each opening must have a minimum free area of 1 square inch (6.4 square centimeters) per 1,000 Btu (293 W) per hour of the total input rating of all fuel-fired equipment in the confined space. Each opening must be at least 100 square inches (614.5 square centimeters). One opening shall be within 12" (305 mm) of the top of the enclosure and one opening within 12" (305 mm) of the bottom (See figure 9).

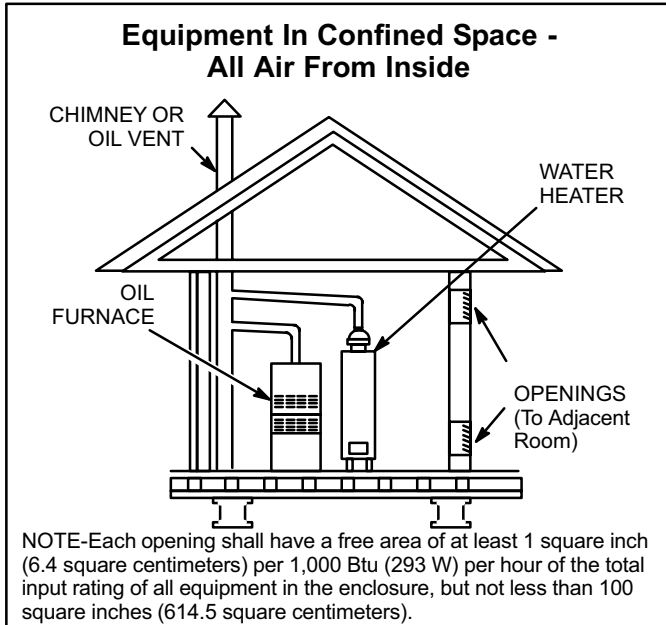

Figure 9

Air from Outside

If air from outside is brought in for combustion and ventilation, the confined space shall be provided with two permanent openings. One opening shall be within 12" (305 mm) of the top of the enclosure and one within 12" (305 mm) of the bottom. These openings must communicate directly or by ducts with the outdoors or spaces (crawl or attic) that freely communicate with the outdoors or indirectly through vertical ducts. Each opening shall have a minimum free area of 1 square inch (6.4 square centimeters) per 4,000 Btu (1172 W) per hour of total input rating of all equipment in the enclosure (See figures 10 and 12). When communicating with the outdoors through horizontal ducts, each

opening shall have a minimum free area of 1 square inch (6.4 square centimeters) per 2,000 Btu (586 W) per total input rating of all equipment in the enclosure (See figure 12).

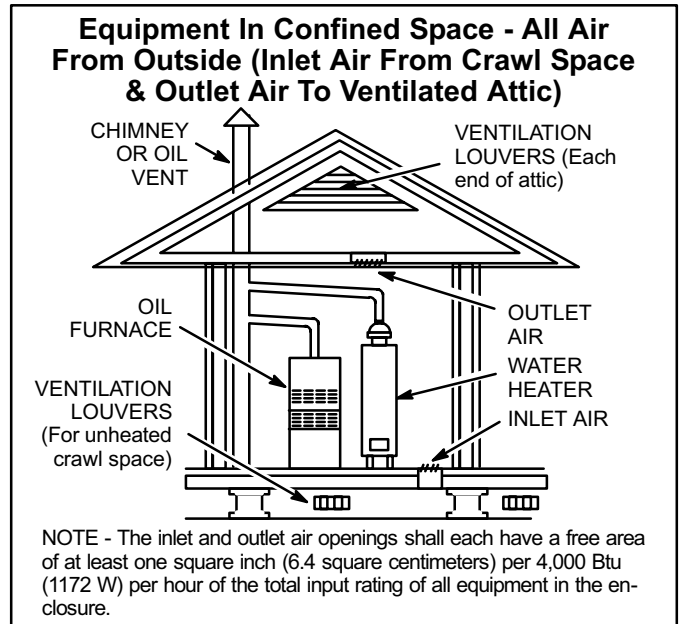

Figure 10

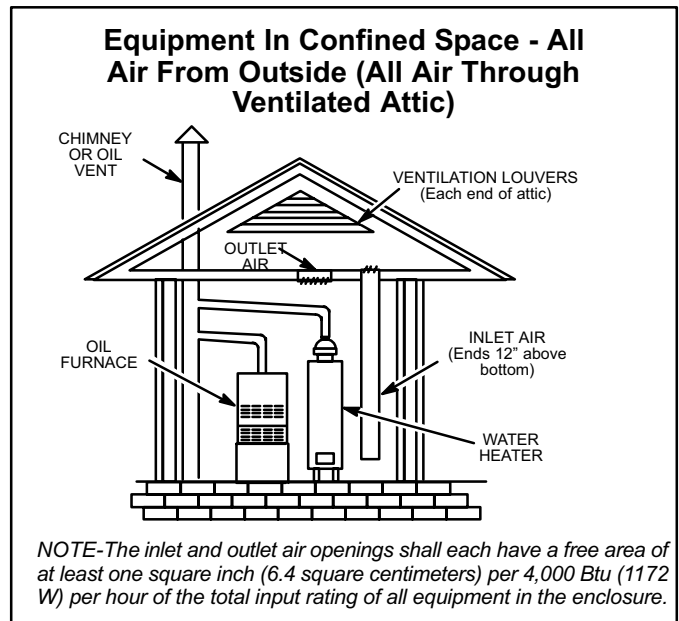

Figure 11

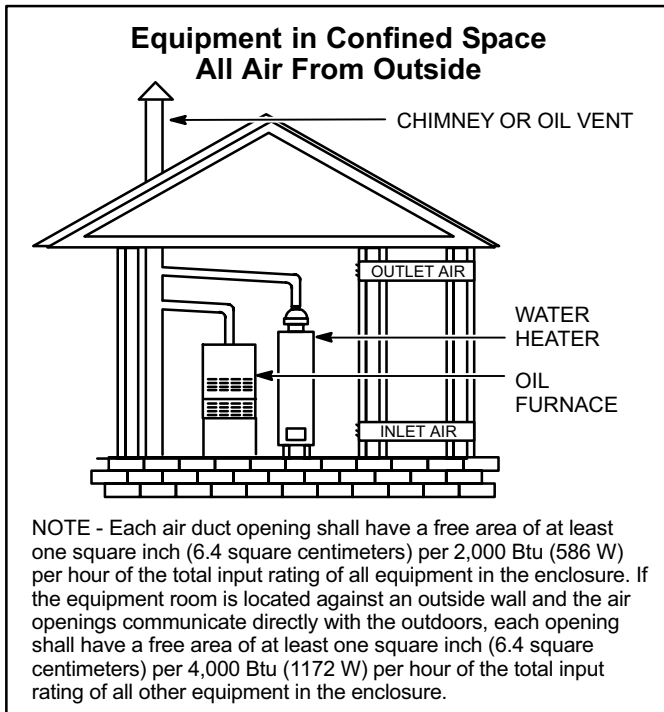

Figure 12

When ducts are used, they shall be of the same cross-sectional area as the free area of the openings to which they connect. The minimum dimension of rectangular air ducts shall be no less than 3" (76 mm). In calculating free area, the blocking effect of louvers, grilles, or screens must be considered. If the design and free area of protective covering is not known for calculating the size opening required, it may be assumed that wood louvers will have 20 to 25% free area and metal louvers and grilles will have 60 to 75% free area. Louvers and grilles must be fixed in the open position or interlocked with the equipment so that they are opened automatically during equipment operation.

Direct Connection of Outdoor Air for Combustion

The Beckett AFII burner was designed to allow for direct air intake piping (4" [102 mm]). The maximum equivalent length of pipe is 70 feet (21.3 m). A 90° elbow equals 6 feet (1.8 m). The enclosed intake pipe ring may be used to facilitate direct air intake to the burner through the right side of the cabinet.

To convert the AFII burner from confined space to outside combustion air, simply remove the three screws attaching the inlet air scoop to the burner and insert 4" (102 mm) direct air intake piping.

The use of a barometric relief placed in the intake pipe is recommended when outdoor combustion air is directly connected to the burner. This will allow confined space air to be used as combustion air in the event that the opening to the outdoor air becomes blocked. Using a barometric relief in the intake will reduce the chance of sooting.

CAUTION

DO NOT USE a barometric draft relief in exhaust vent pipe if outdoor combustion air is connected directly to the burner.

Removal of Unit from Common Venting System

In the event that an existing furnace is removed from a venting system commonly run with separate appliances, the venting system is likely to be too large to properly vent the remaining attached appliances. The following test should be conducted while each appliance is in operation and the other appliances not in operation remain connected to the common venting system. If venting system has been installed improperly, the system must be corrected as outlined in the previous section.

1. Seal any unused openings in the common venting system.
2. Visually inspect venting system for proper size and horizontal pitch and determine there is no blockage or restriction, leakage, corrosion or other deficiencies which could cause an unsafe condition.
3. Insofar as is practical, close all building doors and windows and all doors between the space in which the appliances remaining connected to the common venting system are located and other spaces of the building. Turn on clothes dryers and any appliances not connected to the common venting system. Turn on any exhaust fans, such as range hoods and bathroom exhausts, so they will operate at maximum speed. Do not operate a summer exhaust fan. Close fireplace dampers.
4. Following the lighting instruction on the unit, place the appliance being inspected in operation. Adjust thermostat so appliance will operate continuously.
5. Test for spillage using a draft gauge.
6. After it has been determined that each appliance remaining connected to the common venting system properly vents when tested as outlined above, return doors, windows, exhaust fans, fireplace dampers and any other fuel burning appliance to their previous condition of use.
7. If improper venting is observed during any of the above tests, the common venting system must be corrected.

Horizontal Venting

The O23V is approved for horizontal venting with the following mechanical vent systems:

- Tjernlund (sideshot) #SS1C
 - Field Controls #SWG-5 with the CK-61 control kit
- Refer to the manufacturers' installation instructions for installation procedures and service parts information. Do not use the same vent with any other appliance when using a sidewall vent system.

Maximum permissible vent length is 70 equivalent feet. Minimum length is 15 equivalent feet. Calculate the equivalent vent pipe footage from the furnace to the mechanical vent system (Tjernlund or Field Controls) by adding the straight vent pipe length and the equivalent elbow lengths together.

Locate the barometric draft control within 18 inches of the furnace flue outlet. See figure 13 for barometric draft control location.

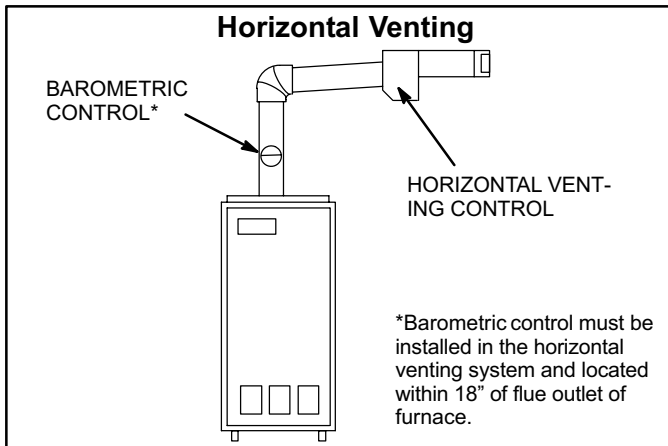

Figure 13

Flue Connections

⚠ IMPORTANT

When flue pipe is installed at less than minimum clearance listed in table 2, radiation shields must be installed. See figure 14.

Use 24 gauge or heavier galvanized smoke pipe and fittings to connect the furnace to the vent. Connect flue pipe to chimney using the least number of elbows and angles possible. Flue pipe or vent connector must be inserted into but not beyond the outside wall of the chimney flue. No reduction in diameter of flue pipe is acceptable. It is best to have flue pipe as short and direct as possible. Where two or more appliances vent into a common flue, the area of the common flue should be at least equal to the area of the largest flue or vent connector, plus 50% of the area of any additional flues or vent connectors. Install a barometric draft control (provided) and flue pipe according to instructions packed with control.

Inspect flue pipe annually. Clean soot or ash from flue pipe, if necessary. If pipe is rusted, replace.

Install draft control at least 12 inches beyond the furnace. If there is no space to install the draft control in the flue pipe it may be installed in the vent above the flue pipe. Follow the instructions packed with the draft control.

Alternate Side Flue Connections

The vent pipe may exit the top or sides of the cabinet. A hole is provided in the top cap for top exit. For side exit, locate the center hole punched in the side of the cabinet. See unit dimensions on page 2. Using it as the center point, cut a 6 inch (152 mm) round hole in the cabinet's side. Install the barometric draft control within 18 inches of the furnace flue outlet.

Attach the provided finishing plate to cover rough edges.

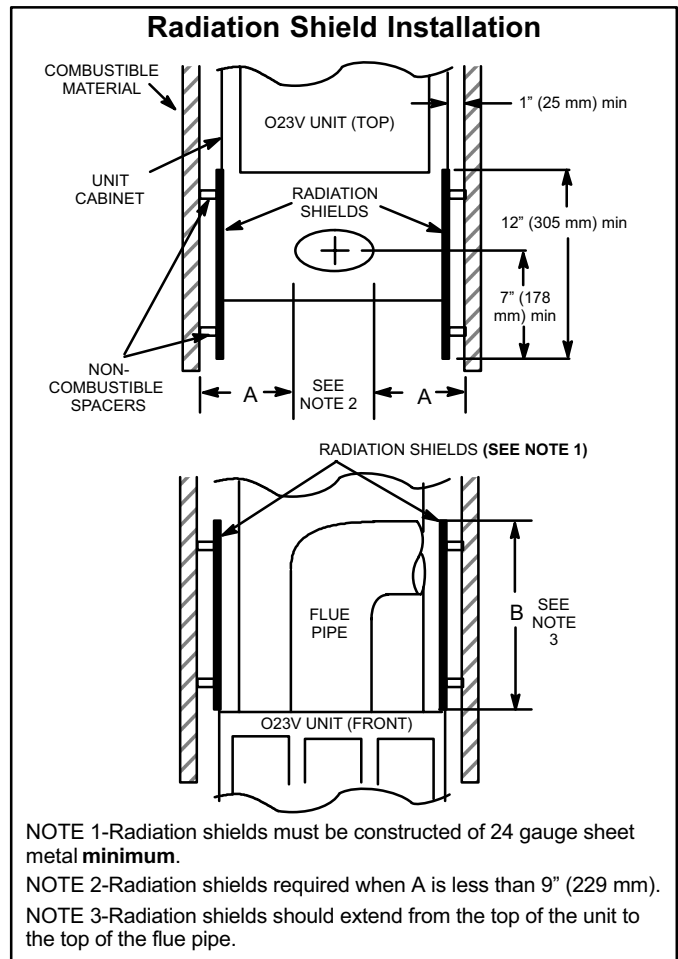

Figure 14

Supply & Return Air Plenums

Secure return air plenum to unit using sheet metal screws. *NOTE - The following are suggested procedures that should be followed when installing the supply air plenum.*

1. Use sealing strips of fiberglass.
2. In all cases, the plenum should be secured to furnace or evaporator cabinet with sheet metal screws.
3. Install supply and return air ducts as desired.

Oil Supply Lines Sizing

Ensure that the restrictions of the piping system, plus any lift involved, do not exceed the capability of the oil pump. Use the following guidelines when determining whether to use a single- or two-stage oil pump.

One-Pipe System

When using a one-pipe system (see figure 15), even with the oil tank that is above the burner and a vacuum of 6" (152 mm) Hg or less, a single-stage fuel pump with a supply line and no return line should be adequate.

Manual bleeding of the fuel pump is required on initial start up. Failure to bleed air from the oil pump could result in an air lock/oil starvation condition.

NOTE - As an extra precaution, cycle heating on and off ten times after bleeding air from the oil pump. This will eliminate air in the gun assembly.

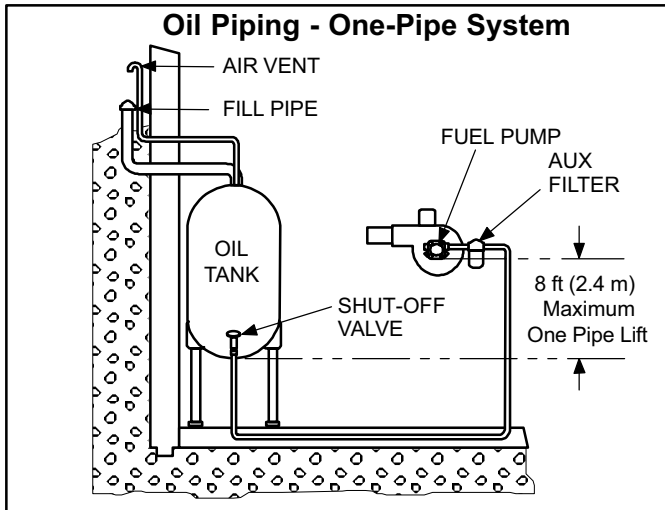

Figure 15

To determine the correct tubing size for piping, refer to table 3

Table 3

One-Pipe Oil Sizing	
Line Length	Pipe Diameter (OD Tubing)
0-50' (15 m)	3/8" (10 mm)
51-100' (15 m)	1/2" (12 mm)

Two-Pipe System

When using a two-pipe system (see figure 16) with the oil tank below the level of the burner, use a single-stage fuel pump in lift conditions of up to 10 feet (3 m) and/or a vacuum of 10" (254 mm) Hg or less. Use a two-stage fuel pump when lift exceeds 10 feet (3 m) and/or a vacuum of 10" (254 mm) Hg to 15" (381 mm) Hg. Both conditions require that you use of a two-pipe system, which consists of a return line that purges the fuel pump of air by returning it to the tank. To determine the run and lift for piping, refer to table 4

Use continuous lengths of heavy wall copper tubing or steel pipe for oil supply pipe. Install oil supply pipe under floor or near walls to protect it from damage. Avoid running pipes along joists or reverberating surfaces. Always use flare fittings. All fittings must be accessible. Do not use compression fittings.

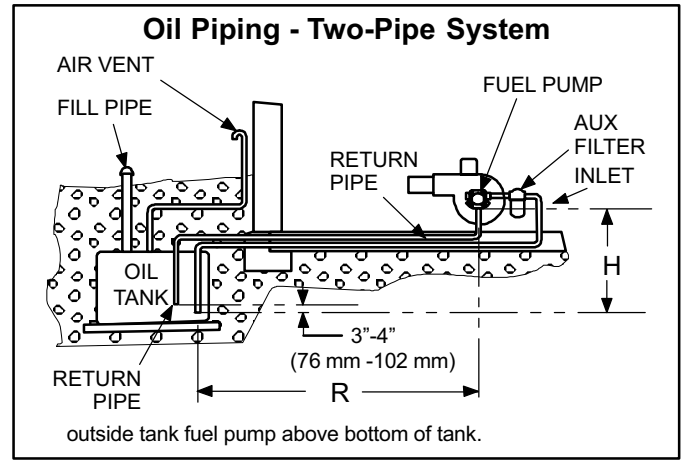

Figure 16

⚠ IMPORTANT

Both oil supply and return pipes must be submerged in oil in the supply tank.

Table 4

Two-Pipe Maximum Pipe Length (H + R) 3450 RPM - 3 GPH (11.4 LPH)				
Lift "H" ft (m)	Single-Stage	Two-Stage	Single-Stage	Two-Stage
	3/8" (10 mm) OD Tubing - ft (m)		1/2" (12 mm) OD Tubing	
0' (0.0)	84 (25.6)	93 (28.3)	100 (30.5)	100 (30.5)
2' (0.6)	73 (22.3)	85 (25.9)	100 (30.5)	100 (30.5)
4' (1.2)	63 (19.2)	77 (23.5)	100 (30.5)	100 (30.5)
6' (1.8)	52 (15.8)	69 (21.0)	100 (30.5)	100 (30.5)
8' (2.4)	42 (12.8)	60 (18.3)	100 (30.5)	100 (30.5)
10' (3.0)	31 (9.4)	52 (15.9)	100 (30.5)	100 (30.5)
12' (3.7)	21 (6.4)	44 (13.4)	83 (25.3)	100 (30.5)
14' (4.3)	---	36 (11.0)	41 (12.5)	100 (30.5)
16' (4.9)	---	27 (8.2)	---	100 (30.5)
18' (5.5)	---	---	---	76 (23.2)

Oil Supply Line & Filter Connections

One-Pipe Systems

CAUTION

Do not install the bypass plug into the pump on one-pipe systems.

The burner is shipped with fuel pump set for one-pipe operation. For one-pipe systems, the oil supply pipe is connected to the inlet tap on the pump. A one-pipe system should only be used where there is gravity oil flow to the pump and the pipe is not run at any point above the oil level in the tank.

1. Connect the inlet pipe to the pump inlet. Start the burner.
2. Arrange the primary burner control for continuous operation during purging (see figure 15).
3. Turn the bleed valve one turn counterclockwise to open.
4. Bleed the unit until all air bubbles disappear.

NOTE - Hurried bleeding will prevent the unit from operating properly.

5. Tighten the bleed valve securely.

Two-Pipe Systems

If the installation requires a two-pipe operation, install the bypass plug included in the bag which is attached to the pump. To convert the pump, install the bypass plug according to the provided pump instructions. Notice in the two-pipe system the return pipe must terminate in the tank 3" (76 mm) to 4" (102 mm) above the supply inlet. Ensure the return pipe terminates at the correct measurement or air may escape into the system. This could result in loss of prime.

NOTE - If using an outside tank in cold climates a number one fuel or an oil treatment is strongly recommended.

1. Remove 1/4" plug from return port.
2. Insert bypass plug and tighten it (see figure 16).
3. Attach the return and inlet pipes. Start the burner. Air bleeding is automatic.

NOTE - If a faster bleed is necessary, open the bleed valve.

4. The return pipe must terminate 3" to 4" above the supply pipe inlet (see figure 16).

NOTE - If the return pipe does not terminate where it should, air may enter the system, and prime may be lost.

An oil filter is required for all models. Install filter inside the building between the tank shut-off valve and the burner. Locate filter close to burner for easy maintenance. Table 5 lists the filters for the O23V furnace.

Table 5

Installation Clearances inches (mm)	
Oil Filters	Cat. No.
10 micron filter (no mounting bracket)	81P89
10 micron replacement cartridge for filter, 45 gph	53P93
Filter restriction indicator gauge	53P90

Consult burner manufacturer's instructions packaged with unit for further details concerning oil supply pipe connections.

Leak Check

After oil piping is completed, carefully check all piping connections (factory and field) for oil leaks.

Oil Pipe Heater (Optional)

A heater for the oil pipe is available for applications that are located in cold climates. The heater warms the oil pipe to assist the initial start-up.

Electrical

Wiring must conform to current National Electric Code ANSI/NFPA No. 70, or Canadian Electric Code Part I, CSA Standard C22.1, and local building codes. Refer to figure 18 for wiring diagram and to unit nameplate for minimum circuit ampacity and maximum overcurrent protection size. Select the proper supply circuit conductors in accordance with tables 310-16 and 310-17 in the National Electric Code, ANSI/NFPA No. 70 or tables 1 through 4 in the Canadian Electric Code, Part I, CSA Standard C22.1.

CAUTION

USE COPPER CONDUCTORS ONLY.

This unit is provided with holes for conduit. Reducer washers are provided for sizing the hole to allow for smaller conduit. Use provided caps to seal holes not used. Refer to figure 17 for the terminal designations on the A54 blower control board. Refer to figure 18 for unit schematic wiring diagram with typical field wiring.

Separate openings are provided for 24V low voltage and for line voltage. Refer to figure 1 for specific location.

WARNING

Run 24V Class II wiring only through specified low voltage opening. Run line voltage wiring only through specified high voltage opening. Do not combine voltage in one opening.

1. Refer to the appliance rating plate for proper fuse size.

⚠ IMPORTANT

If using a programmable thermostat, be sure to use a type of thermostat that retains its memory in event of a power loss.

2. Install the room thermostat and make wire connections to the fan control board. Avoid installing thermostat on an outside wall or where it can be affected by radiant heat. Set the adjustable heat anticipator on thermostat according to the wiring diagram sticker provided on unit.
3. Install a separate fused disconnect switch near unit so power can be shut off for servicing.
4. Complete line voltage wiring from disconnect switch near unit to make-up box.

NOTE - An equipment ground screw is provided. Refer to unit wiring diagram and figure 18 for O23V series units. Ground unit using a suitable ground wire.

5. Any accessory rated up to 1 amp can be connected to the EAC terminal. (EAC terminal is energized when the blower is operating.)

Blower Control

⚠ WARNING



Electric shock hazard. Can cause injury or death. Before attempting to perform any service or maintenance, turn the electrical power to unit OFF at disconnect switch(es). Unit may have multiple power supplies.

Blower Control Board (A54)

O23V units are equipped with a variable speed motor which is controlled by the A54 blower control board. Blower control board settings and operation are described in this section.

O23V units equipped with a variable speed motor are capable of maintaining a specified CFM throughout the external static range. A particular CFM can be obtained by positioning **COOL** jumpers on the blower control board. The COOL jumper selections are labeled A, B, C and D; each letter corresponds with an air volume (CFM) setting. The **ADJUST** jumper is labeled Test, -, +, and Norm. The + and - pin settings are used to add or subtract a percentage of the CFM selected. The Test jumper is used to operate the motor in the test mode. See figure 17.

Factory settings for the blower speed jumpers are given in the wiring diagram in figure 18. Figure 17 shows the blower control board. Use table 6 to determine the correct air volume for operation in heat and cool mode.

The **CFM** LED located on the blower control board flashes one time per 100 cfm to indicate selected blower speed. For example, if the unit is operating at 1000 CFM, **CFM** LED will flash 10 times.

At times, the light may appear to flicker or glow. This takes place when the control is communicating with the motor between cycles. This is normal operation. Read through the jumper settings section before adjusting the jumper to obtain the appropriate blower speed.

To change jumper positions, gently pull the jumper off the pins and place it on the desired set of pins. The following section outlines the different jumper selections available and conditions associated with each one (see figure 17).

After the CFM for each application has been determined, the jumper settings must be adjusted to reflect those given in table 6. From the table, determine which row most closely matches the desired CFM. Once a specific row has been chosen (+, NORMal, or -), CFM volumes from other rows cannot be used. Below are descriptions of the jumper selections.

The variable speed motor slowly ramps up to and down from the selected air flow during both cooling and heating demand. This minimizes noise and eliminates the initial blast of air when the blower is initially energized.

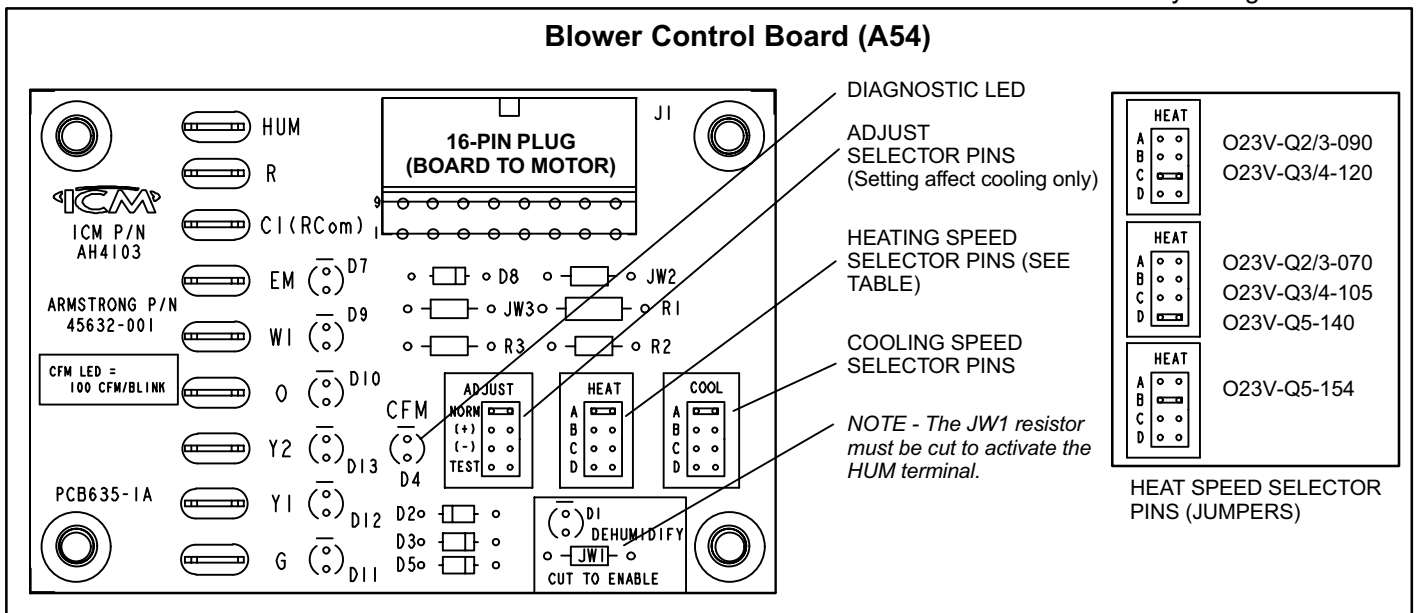

Figure 17

ADJUST

The **ADJUST** pins allow the motor to run at normal speed, approximately 15% higher than normal speed, or 15% lower than normal speed. Table 6 gives three rows—NORM, (+), and (–) with their respective CFM volumes. Notice that the normal “NORM” adjustment setting for cool speed position C in table 6 is 800 CFM. The “(+)” adjustment setting for that position is 920 CFM (115% of 800 CFM) and the “(–)” adjustment setting is 680 CFM (85% of 800 CFM). After the adjustment setting has been determined, choose the remaining speed settings from those offered in the table in that row.

The **TEST** pin is available to bypass the blower control and run the motor at approximately 70% to make sure that the motor is operational. This is used mainly in troubleshooting. The **G** terminal must be energized for the motor to run.

COOL (single-stage systems)

The **COOL** jumper is used to determine the CFM during cooling operation. This jumper selection is activated for cooling when Y1 is energized. Y1 and Y2 must be jumpered for single stage cooling.

The blower motor runs at 82% CFM for the first 7-1/2 minutes of each cooling demand to allow for greater humidity removal and to conserve energy. If, after 7-1/2 minutes, the Y demand is not met, 100% CFM is supplied until the demand is satisfied.

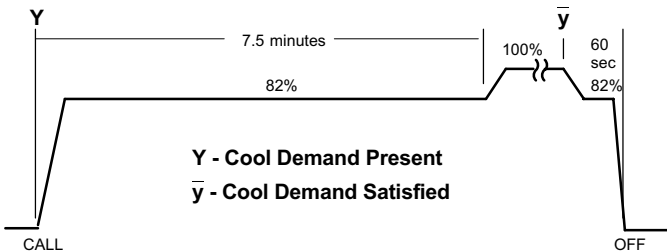

When the demand for cool is met, the blower ramps down to 82% CFM for 60 seconds, then turns off.

COOL (two-stage systems)

⚠ IMPORTANT

The unit is factory set for single-stage cooling. For two-stage cooling operation, the jumper wire from Y1 to Y2 on the blower control board must be cut (at terminal Y1) and connected to Y2 from the thermostat (A54 board “Y2” to thermostat “Y2”). See figure 18 wiring diagram.

A thermostat call for first-stage cooling closes the R to Y1 circuit on the A54 blower control board. The blower motor runs at 57% CFM for the first 7-1/2 minutes of the 1st-stage cooling demand. After 7-1/2 minutes, the blower motor runs at 70% CFM until the first-stage demand is satisfied.

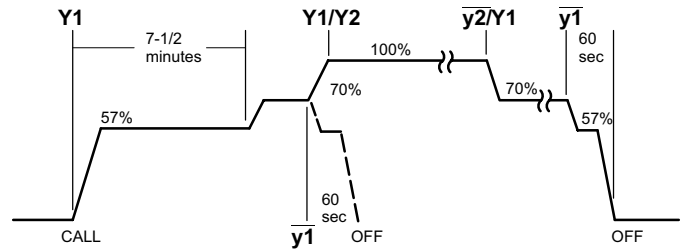

If first-stage cooling does not satisfy the demand, the thermostat calls for 2nd-stage cooling, closing the R to Y2 circuit on the A54 blower control board. The blower motor ramps up to 100% CFM.

When the Y2 demand is met, the blower ramps down to Y1 at 70% CFM until Y1 is met, and ramps down to 57% CFM for 1 minute, then turns off.

HEAT

The unit is factory-set to run at the middle of heating rise range as shown on the unit rating plate. The jumper on the tap marked **HEAT** should remain in the position (A, B, D, or D) as shown in the HEATING SPEED SELECTOR PINS graphic found in the wiring diagram (figure 18).

The **HEAT** jumper is used to determine CFM during gas heat operation only. These jumper selections are activated only when W1 is energized.

During the heat ON delay, the blower runs at 13% CFM for the first minute, 50% CFM for the second minute, and full CFM after two minutes.

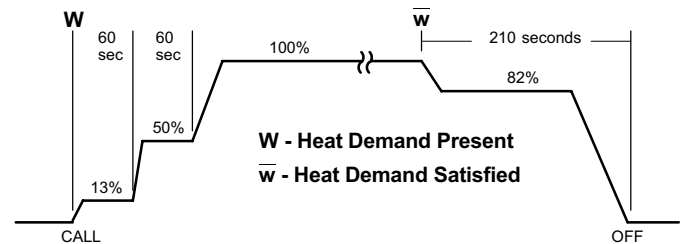

When the demand for heat is met, the blower ramps down to 82% CFM for 3-1/2 minutes, then turns off.

Heat Pump

⚠ IMPORTANT

For heat pump operation, cut the jumper between R and O near the R terminal of A54 and connect the pigtail to the thermostat O wire (A54 board “O” to thermostat “O”). See figure 18 wiring diagram.

In heat pump mode, a call for heat pump operation follows the same sequence as a call for cooling, with the exception that there is a 30-second blower ramp-up to blower CFM.

Continuous Fan

When the thermostat is set for “Continuous Fan” operation and there is no demand for heating or cooling, the blower control will provide 50% of the **COOL** CFM selected.

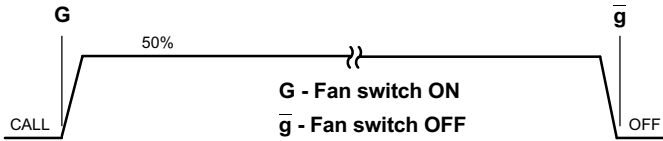

NOTE - With the proper thermostat and subbase, continuous blower operation is possible by closing the R to G circuit.

Dehumidification

The A54 blower control board (see figure 17) includes a

HUM terminal which provides for connection of a humidistat. The JW1 jumper on the blower control board must be cut to activate the HUM terminal. The humidistat must be wired to open on humidity rise. When the dehumidification circuit is used, the variable speed motor will reduce the selected air flow rate by 18% when humidity levels are high. An LED (D1) lights when the blower is operating in the dehumidification mode.

Humidification

Terminals are provided on the A15 control board for 120 volt output to operate a humidifier. The “HUM” terminal is energized when there is a call for heat. See figure 18.

Electronic Air Cleaner

Terminals are provided on A15 control board for 120 volt output to an electronic air cleaner. The “EAC” terminal is energized when there is a call for heat, cool, or continuous blower. See figure 18.

Table 6

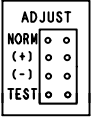
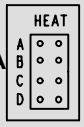
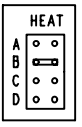
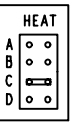
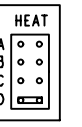
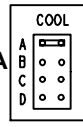
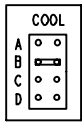
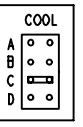
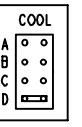
Blower Performance {0 through 0.80 in. w.g. (0 through 200 Pa) External Static Pressure Range}																
“ADJUST” Jumper Setting 	“HEAT” Jumper Speed Position [kBtuh heat input]				“COOL” Jumper Speed Position											
																
	cfm	L/s	cfm	L/s	cfm	L/s	cfm	L/s	cfm	L/s	cfm	L/s	cfm	L/s		
Model O23V2/3-70/90 Units																
	Do not use	Do not use	[-90]		[-70]											
(+)	N/A	N/A	N/A	N/A	Same as NORM		1380	650	1150	545	920	435	690	325		
NORM	N/A	N/A	N/A	N/A	1000	470	750	355	1200	565	1000	470	800	380	600	285
(-)	N/A	N/A	N/A	N/A	Same as NORM		1020	480	850	400	680	320	510	240		
Model O23V3/4-105/120 Units																
	Do not use	Do not use	[-120]		[-105]											
(+)	N/A	N/A	N/A	N/A	Same as NORM		1610	760	1380	650	1150	540	920	435		
NORM	N/A	N/A	N/A	N/A	1300	615	1200	565	1400	660	1200	565	1000	470	800	380
(-)	N/A	N/A	N/A	N/A	Same as NORM		1190	560	1020	480	850	400	680	320		
Model O23V5-140/154 Units																
	Do not use	[-154]		Do not use		[-140]										
(+)	N/A	N/A	Same as NORM		N/A	N/A	Same as NORM		2300	1085	2070	975	1840	870	1380	650
NORM	N/A	N/A	1730	816	N/A	N/A	1400	660	2000	945	1800	850	1600	755	1200	565
(-)	N/A	N/A	Same as NORM		N/A	N/A	Same as NORM		1700	800	1530	720	1360	640	1020	480
<i>NOTE - Continuous Fan air volume is 50% of COOL speed.</i>																

O23V Wiring Diagram

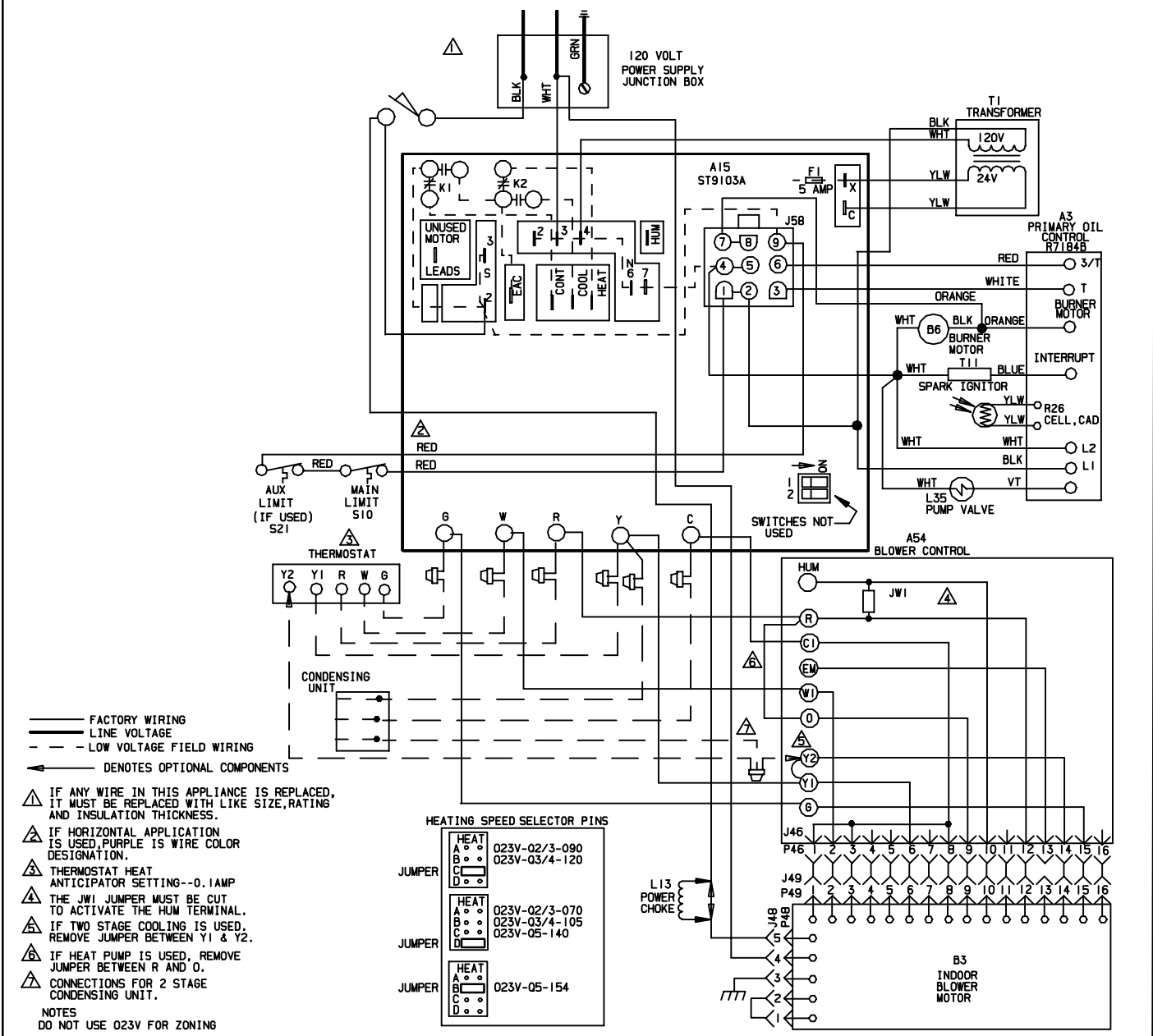

Figure 18

Unit Start-Up & Adjustments

Before starting unit, make sure the oil tank is adequately filled with clean No. 1 or No. 2 furnace oil.

NOTE - Water, rust or other contaminants in oil supply system will cause malfunction and failure of the internal parts of the fuel pump.

CAUTION

Never burn garbage or paper in the heating system. Never leave papers near or around the unit.

Blower door must be in place before start-up.

1. Set thermostat for heating demand and turn on electrical supply to unit.
2. Check initial air adjustment. All units are equipped with an air adjustment dial on the right side of the burner. See burner parts arrangement illustration.
3. Turn unit on. Place a can or container under the bleed port located on the fuel pump. Loosen nut on bleed port to release air and oil mixture from fuel line. Allow mixture to escape until a steady stream of oil is emitted from the port. Drain at least 1/2 pint of oil from the pump. Retighten the nut on bleed port. If lockout occurs, press reset button and continue with bleed procedure.

NOTE - A two-pipe fuel system will normally bleed itself by forcing air back to the tank through the return line. This type of bleeding procedure is not necessary.

4. If burner fails to start, push reset button on primary safety control and the burner motor reset button. See part arrangement illustration.

CAUTION

Do not push the reset button on the primary control more than one time.

5. If the burner fails to light again, refer to the troubleshooting section in this manual.

Measuring Fuel Pump Pressure

Measure fuel pump pressure with unit off. Attach pressure gauge to pump outlet. Turn unit on and check pressure and compare to table 7. Adjust if necessary.

Measuring Temperature Rise

To measure temperature rise, place plenum thermometers in warm air and return air plenums. Locate thermometer in warm air plenum where thermometer will not "see" the heat exchanger to prevent it from picking up radiant heat. Set thermostat to its highest setting to start unit. After plenum thermometers have reached their highest and steadiest readings, subtract the readings. The difference in temperatures in the supply and return air plenums should approximate the temperature rise range listed in table 7 and the appliance rating plate. If the rise is above the range shown in the table, check for high static pressure.

Table 7

O23V Unit	Nozzle Size, Spray Angle, & Pattern	Pump PSIG	Input Rating BTU/Hr	Output Rating BTU/Hr	Head	Temp Rise F°
-70	.50GPH-80° A	100	70,000	57,000	FB0	60-70
-90	.65GPH-80° B	100	90,000	72,000	FB0	60-70
-105	.65GPH-80° B	140	105,000	84,000	FB3	65-75
-120	.75GPH-80° B	140	119,000	105,000	FB3	70-80
-140	.85GPH-80° B	140	140,000	112,000	FB6	65-75
-154	1.0GPH-80° B	140	154,000	125,000	FB6	70-80

Adjusting Limit Control

DO NOT adjust limit control - it is preset at the factory.

Adjusting and Testing Burner

The following instructions are essential to the proper operation of O23V series oil furnaces. To prevent sooting, these instructions must be followed in sequence:

1. **Draft**—This test should be taken at the breach between the outlet of the vent connector and the barometric draft control. Generally a 1/4" hole will need to be drilled for the draft gauge to be inserted into the vent connector.

A minimum of 0.03 draft must be established without the burner in operation. With the burner in operation, the draft should be 0.04 to 0.05. This is VERY critical to the flame retention head burners.

Oil furnace installations also require careful inspection to make sure the chimney is in good shape and can accommodate the products of combustion. The temperature in the unconditioned space will also affect the draft if long vent connectors are allowed to get too cold.

2. **Overfire Draft**—This test should be taken with the burner in operation. Remove the screw from the center of the inspection port. Insert your draft gauge into the hole.

A reading of the overfire draft should be 0.02 less than the reading found in the vent connector. If a positive reading is seen at this point, the combustion fan is pumping too much air into the heat exchanger. Make the necessary adjustments at the air adjustment dial.

3. **Smoke Test**—The smoke test should be taken at the hole drilled in step 1.

Using a smoke test gun adjust the air inlet shutter so that you will have just a trace of smoke. Somewhere between a 0 and #1 smoke. This is the *starting* point. Do not stop here.

4. **CO₂ Test**—Again, take this sample at the vent pipe. With the unit firing at a trace of smoke, take a sample of the CO₂. From the results of this test, a "window of operation" will be determined. This window of operation establishes some tolerance. The tolerance the installer builds in provides room within the set-up for those things which might affect combustion. Those things which might affect combustion can then do so without

causing the unit to start sooting/smoking. Things which might affect combustion include a nozzle going bad, draft that changes during different climatic conditions, dirty oil, dirt obstructing the air inlet, etc.

To build in a “window of operation,” set up the burner to be 2% less in CO₂. For example, if you find a reading of 12% CO₂, adjust the air inlet shutter to increase the air and drop the CO₂ to 10%.

5. **Retest the Smoke**—With a drop in the CO₂ and increase in the air you should see that the smoke has returned to 0.
6. **Retest the Overfire Draft**—This test serves to confirm that you have not increased the air too much. Again you do not want a positive pressure at the test port. It should still be 0.02 less than the draft pressure reading taken at the breach. You may need to increase the stack draft by adjusting the barometric draft control.
7. **Stack Temperature**—Take a stack temperature reading in the vent pipe. Subtract the room air temperature from the stack temperature. This will give you the net stack temperature. Use the efficiency charts provided in most CO₂ analyzers to determine furnace efficiency.

Service

CAUTION

Do not tamper with unit controls. Call your qualified service technician.

Servicing the Air Filter

NOTE - Under no circumstances should the access panels to the blower compartment be left off or left partially open.

Throw-Away Type Filters—Check filters monthly and replace when necessary to assure proper furnace operation. Replace filters with like kind and size filters.

Reusable Type Filters—Filters should be checked monthly and cleaned when necessary to assure proper furnace operation.

Servicing the Blower

Blower motor is prelubricated and sealed for extended operation. No further lubrication is required. Disconnect power to unit before cleaning blower wheel for debris.

Inspecting the Flue Pipe

The flue pipe should be inspected annually by a qualified service technician. Remove and clean any soot or ash found in the flue pipe. Inspect pipe for holes or rusted areas. If replacement is necessary, replace with the same size and type as required by code. Inspect the flue draft control device and replace if found defective.

Cleaning the Heat Exchanger

1. Remove the vent pipe from the furnace.
2. Remove the locking screws and the caps from the clean out tubes. Remove flue access elbow.
3. Using a long spiral wire brush, sweep down the outer drum of the heat exchanger. Then using the hose attachment, vacuum out loose debris.

4. Remove the locking screw and cap from the observation tube and with the spiral wire brush, reach upward toward the rear of the heat exchanger to clean out the crossover tube.

CAUTION

Do not attempt to clean the combustion chamber. It can be easily damaged.

5. Replace the three clean out caps and flue access elbow. Make sure locking screws are secure.
6. Brush out and vacuum the vent outlet area of the outer drum and replace vent pipe.
7. Clean around the burner, blower deck and vestibule area.

NOTE - A heat exchanger clean-out kit ABRSH380 (35K09) is available from Lennox.

Servicing the Oil Burner

The nozzle and oil filter must be checked before each heating season. Also, recheck the conditions shown in the Oil Furnace Start-up Checklist (see page 24).

NOTE - Close the oil line shutoff valve if the burner is shut down for an extended period of time.

Heating Events - Actions & Responses

1. **Action: Thermostat calls for heat** (W terminal is energized)

Response:

- Blower control board closes oil primary control T-3T connections.
- After a 15-second pre-purge period, power is sent to the burner and ignition is established. When the burner pump reaches full speed, the solenoid valve is energized.
- Ignition system and oil primary control start the furnace. Oil flows as long as oil primary control senses flame.
- Burner motor energized and heat fan on ramp timing begins. When timing is complete, the circulating fan is at heat speed and warm air is delivered to the controlled space.

2. **Action: Thermostat ends call for heat** (W terminal is de-energized)

Response:

- Oil primary control is de-energized, terminating the burner cycle.
- Heat fan off ramp timing begins. When timing is complete, circulating fan is de-energized.
- Blower control board returns to standby mode (oil primary control and circulating fan are off).
- After the thermostat is satisfied, the thermostat circuit opens. The solenoid valve is de-energized before the pump rotation stops. Power to the burner is interrupted, shutting down the burner.

3. **Action: Burner fails to light**

Response:

- Oil primary control locks out within lockout timing (timing depends on oil primary control).
- Burner motor is de-energized.

4. Action: Established flame fails

Response:

- Burner motor is de-energized and oil primary control goes into recycle mode.
- If the fan off delay is longer than the recycle timing, the heat fan continues to run through the next trial for ignition.

5. Action: Limit Switch Opens

Response:

- Oil primary control shut off the burner.
- Circulating fan is energized immediately at cool speed.
- A15 control board opens oil primary control T-3T connections.
- Circulating fan runs as long as limit stays open.

6. Action: Limit Switch Closes

Response: If there is a heat demand, A15 control board energizes oil primary control, initiating burner light off.

Troubleshooting

Burner failure or improper operation can result from a number of different causes. Often the cause can be pinpointed by observing the different types of failure or by the process of elimination. The following troubleshooting charts list some failures, causes and a sequence of steps to isolate the point of failure. Check the simplest and most obvious items before progressing to other items.

Troubleshooting: Burner fails to start			
Source	Procedure	Causes	Correction
Thermostat	Check thermostat settings.	Thermostat in OFF or COOL	Switch to HEAT .
		Thermostat is set too low	Turn thermostat to higher temperature.
Safety Overloads	Check burner motor, primary safety control, & auxiliary limit switch.	Burner motor overload tripped	Push reset button pump motor.
		Primary control tripped on safety	Reset primary control.
		Auxiliary limit switch tripped on safety	Reset auxiliary limit.
Power	Check furnace disconnect switch & main disconnect.	Open switch	Close switch.
		Blown fuse or tripped circuit breaker	Replace fuse or reset circuit breaker.
Thermostat	Touch jumper wire across thermostat terminals on primary control. If burner starts, then fault is in the thermostat circuit.	Broken or loose thermostat wires	Repair or replace wires.
		Loose thermostat screw connection	Tighten connection.
		Dirty thermostat contacts	Clean contacts.
		Thermostat not level	Level thermostat.
		Faulty thermostat	Replace thermostat.
CAD Cell	Disconnect the flame detector wires at the primary control. If the burner starts, fault is in the detector circuit.	Flame detector leads are shorted	Separate leads.
		Flame detector exposed to light	Seal off false source of light.
		short circuit in the flame detector	Replace detector.
Primary Control	Place trouble light between the black and white leads. No light indicates that no power is going to the control.	Primary or auxiliary control switch is open	Check adjustment. Set the maximum setting. Jumper terminals; if burner starts, switch is faulty, replace control.
		Open circuit between disconnect switch and limit control	Trace wiring and repair or replace it.
		Low line voltage or power failure	Call the power company.
	Place trouble light between the orange and white leads. No light indicates faulty control.	Defective internal control circuit	Replace the control.

table continued on next page

Troubleshooting: Burner fails to start			
Source	Procedure	Causes	Correction
Burner	Place the trouble light between the black and white leads to the burner motor. No light indicates that no power is getting to the motor.	Blown fuse	Replace the fuse.
	Place trouble light between the black and white leads to the blower motor. Light indicates power to the motor and burner fault.	Binding burner blower wheel	Turn off power and rotate the blower wheel by hand. If seized, free the wheel or replace the fuel pump.
		Sized fuel pump	
		Defective burner motor	Replace the motor.

Troubleshooting: Burner starts, but no flame is established			
Source	Procedure	Causes	Correction
Oil Supply	Check tank gauge or use dip stick.	No oil in tank	Fill tank.
	Coat dip stick with litmus paste and insert into bottom of tank.	Water in oil tank	If water depth exceeds 1 inch, pump or drain water.
	Listen for pump whine.	Tank shut-off valve closed	Open valve.
Oil Filters & Oil Line	Listen for pump whine.	Oil line filter is plugged Kinks or restriction in oil line Plugged fuel pump strainer	Replace filter cartridges. Repair or replace oil line. Clean strainer or replace pump.
	Open bleed valve or gauge port. Start the burner. No oil or milky oil indicates loss or prime.	Air leak in oil supply line	Locate and correct leak. Tighten all connections.
Oil Pump	Install pressure gauge on pump and read pressure. Should not be less than 140 psi.	Pump is partially or completely frozen. No pressure and the motor locks out on overload.	Replace pump.
		Coupling disengaged or broken - no pressure	Re-engage or replace coupling.
		Fuel pressure too low	Adjust to 100 psi.
Nozzle	Disconnect ignition leads. Observe the oil spray (gun assembly must be removed from unit). Inspect the nozzle for plugged orifice or carbon build-up around orifice.	Nozzle orifice plugged Nozzle strainer plugged Poor or off center spray	Replace nozzle with the same size, spray angle, and spray type.
Ignition Electrodes	Remove gun assembly and inspect electrodes and leads.	Fouled or shorted electrodes	Clean electrode leads.
		Dirty electrodes and leads	
		Eroded electrode tips	Clean electrode tips and reset the gap to 5/32 inches and correctly position tips.
		Improper electrode gap spacing	
		Improper position of electrode tips	
		Bad buss bar connection	Re-tension and realign.
		Cracked or chipped insulators	Replace electrode.
Cracked or burned lead insulators	Replace electrode leads.		
Ignition Transformer	Connect ignition leads to the transformer. Start burner and observe spark. Check line voltage to transformer primary.	Low line voltage	Check voltage at power source. Correct cause of voltage drop or call the power company.
		Burned out transformer windings.	Replace the transformer.
		No spark or weak spark	Properly ground the transformer case.

table continued on next page

Troubleshooting: Burner starts, but no flame is established			
Source	Procedure	Causes	Correction
Burner Motor	Motor does not come up to speed and trips out on overload. Turn off power and rotate blower wheel by hand to check for binding or excessive drag.	Low line voltage	Check voltage at power source. Correct cause of voltage drop or the call power company.
		Pump or blower overloading motor	Correct cause of overloading.
		Faulty motor	Replace motor.

Troubleshooting: Burner starts and fires, but lock out on safety			
Source	Procedure	Causes	Correction
Poor Fire	After burner fires, immediately jumper across flame detector terminals at the primary control. • If burner continues to run, this may be due to poor fire. Inspect fire.	Unbalanced fire	Replace nozzle
		Too much air - -lean short fire	Reduce combustion air - check combustion.
		Too little air - - long dirty fire	Increase combustion air - check combustion.
		Excessive draft	Adjust barometric damper for correct draft.
		Too little draft or restriction	Correct draft or remove restriction.
Flame Detector	• If fire is good, fault is in the flame detector. Check detector circuit.	Dirty cad cell face	Clean cad cell face.
		Faulty cad cell - exceeds 15000 hms	Replace cad cell.
		Loose or defective cad cell wires	Secure connections or replace cad cell holder and wire leads.
Primary Control	• If burner locks out on safety, fault is in the primary control.	Primary control circuit defective	Replace primary control.

Troubleshooting: Burner starts and fires, but short cycles (too little heat)			
Source	Procedure	Causes	Correction
Thermostat	Check thermostat.	Heat anticipator set too low	Correct heat anticipator setting.
		Vibration at thermostat	Correct source of vibration.
		Thermostat in the path of a warm air draft	Shield thermostat from draft or relocate.
Limit Control	Connect voltmeter between line voltage connections to primary control (black & white leads). If burner cycles due to power interruption, it is cycling on limit.	Dirty furnace air filters	Clean or replace filter.
		Blower running too slow	Increase blower speed to maintain proper temp. rise. Check for high static pressure. Check HEAT selector pin per wiring diagram (figure 18, page 16).
		Blower motor seized or burned out	Replace motor.
		Blower bearings seized	Replace bearings and shaft.
		Blower wheel dirty	Clean blower wheel.
		Blower wheel in backward	Reverse blower wheel.
		Wrong motor rotation	Replace with properly rotating wheel.
		Restrictions in return or supply air system	Correct cause of restriction.
Adjustable limit control set too low	Reset limit to maximum stop setting.		

table continued on next page

Troubleshooting: Burner starts and fires, but short cycles (too little heat)

Source	Procedure	Causes	Correction
Power	If voltage fluctuates, fault is in the power source. Recheck voltage at the power source.	Loose wiring connection	Locate and secure connection.
		Low or fluctuating line voltage	Call power company.

Troubleshooting: Burner starts and fires, but loses flame and lock out on safety

Source	Procedure	Causes	Correction
Poor Fire	After burner fires, immediately jumper across flame detector terminals at the primary control. • If burner continues to run (does not lock out of safety), fault may be poor fire. Inspect fire.	Unbalanced fire	Replace nozzle
		Too much air - - lean short fire	Reduce combustion air - check combustion.
		Too little air - - long dirty fire	Increase combustion air - check combustion.
		Excessive draft	Adjust barometric damper for correct draft.
		Too little draft or restriction	Correct draft or remove restriction.
Flame Detector	• If fire is good, check for fault in flame detector circuit.	Dirty CAD cell face	Clean CAD cell face.
		Faulty CAD cell - - exceeds 15000 hms	Replace CAD cell.
		Loose or defective cad cell wires	Secure connections or replace cad cell holder and wire leads.
		Pump loses prime - air slug	Prime pump at bleed port
Oil Supply	• If burner loses flame (does not lock out on safety), fault is in the fuel system.	Pump loses prime - air leak in supply line	Check supply line for loose connections and tighten fittings.
		Water slug in line	Check oil tank for water (over 1 inch) pump or drain out water.
		Partially plugged nozzle or nozzle strainer	Replace nozzle.
	Listen for pump whine	Restriction in oil line	Clear restriction.
		Plugged fuel pump strainer	Clean strainer or replace pump.
		Cold oil - outdoor tank	Change to number 1 oil.

Troubleshooting: Burner runs continuously (too much or too little heat)

Too much heat

Source	Procedure	Causes	Correction
Thermostat	Disconnect thermostat wires at the primary control. • Burner turns off: thermostat circuit faulty.	Shorted or welded thermostat contacts	Repair or replace the thermostat.
		Stuck thermostat bimetal	Clear obstruction or replace thermostat.
		Thermostat not level	Level thermostat.
		Shorted thermostat wires	Repair short or replace wires.
		Thermostat out of calibration	Replace thermostat.
		Thermostat in cold draft	Correct draft or relocate the thermostat.
Primary control	• Burner not turning off: primary control faulty.	Defective primary control	Replace the defective primary control.

Too little heat

Combustion	Check burner combustion for CO ₂ , stack temperature, and smoke • Low CO ₂ less than 10%. • High smoke reading more than a trace.	Too much combustion air	Reduce combustion air.
		Air leaks into heat exchanger around inspection door, etc.	Correct cause of air leak.
		Excessive draft	Adjust barometric draft control for correct draft.
		Incorrect burner head adjustment	Correct burner head setting.
		Dirty or plugged heat exchanger	Clean heat exchanger. Readjust burner.
		Insufficient draft	Increase draft.
	• High stack temperature is more than 550°F net.	Incorrect burner head adjustment	Correct burner setting.
		Too little combustion air	Increase combustion air.
		Too little blower air	Check for high static pressure. Check HEAT selector pin per wiring diagram (figure 18, page 16).
		Dirty or plugged heat exchanger	Clean heat exchanger.
		Dirty blower wheel	Clean blower wheel.
		Dirty furnace air filters	Clean or replace filter.
		Restricted or closed registers/dampers	Readjust registers or dampers.
Oil Pressure	Inspect fire and check oil pressure.	Partially plugged or defective nozzle	Replace nozzle.
		Oil pressure too low: less than 100 psi.	Increase oil pressure top 100psi.

Oil Furnace Start-Up Checklist (Complete this page and keep for future reference)

Customer Name _____ Street Address _____ City _____ State/Zip Code _____

Furnace Model # _____ Serial # _____ Input Rate _____ Nozzle Used _____

New Construction _____ Replacement _____ Date of Installation _____

Installation Data

Furnace Location:

- A Basement - Open _____ Enclosed* _____
- B Utility Room - Open _____ Enclosed* _____
- C Closet - Open _____ Enclosed* _____
- D Crawl Space - Open _____ Enclosed* _____

*Provisions must be made for adequate air for combustion. See **Combustion and Ventilation Air** on page 7.

Chimney Data:

- A Inside/Outside _____
- B Brick _____ Masonry _____
- C Lined _____ Size _____
- D Type: Class A All purpose _____ Type: L _____
- E Condition _____

Flue Pipe:

- A Distance to Chimney _____ Pitch _____
- B Diameter _____
- C Barometric Damper Installed _____
- D Drill 5/16" hole in flue pipe 12" upstream of barometric damper _____
- E Drafting Reading: _____
- F Adjust Barometric: _____

Oil Tank Data:

- A Installed in Basement _____
- B Installed Outside _____
- C Buried/Depth _____
- D Size _____ Gallons _____
- E Age _____
- F Last cleaned on date _____

Oil Lines:

- A Size: 3/8" _____ 1/2" _____ Other _____
- B Single Pipe _____ Two Pipe _____
- C Distance from Tank _____ Lift _____
- D Filter Type _____ Inspect _____ Change _____
- E Pressure Test _____
- F All fittings checked for tightness _____

Thermostat

- A Type: Heating _____ Cooling _____
- B Anticipator Set: _____
- C Wires: New _____ Old _____

Air Filter

- A Filter Type: Permanent _____ Disposable _____
- B Installed: _____
- C Size: _____

Start-Up Procedure

- A Close disconnect switch _____
- B Set thermostat to call for heat _____
- C Bleed air from lines and pump; run for 20 seconds after bubble disappears _____
- D Install vacuum gauge; check pump vacuum _____
- E Install pressure gauge; adjust pressure gauge to 140 psig. Always verify proper pump pressure to corresponding tables with instructions supplied with unit.
- F After 10 minutes operating, obtain flue temperature reading:
1st _____ 2nd _____ 3rd _____
- G Obtain smoke reading:
1st _____ 2nd _____ 3rd _____
- H Measure CO₂:
1st _____ 2nd _____ 3rd _____
- I Check draft overfire: _____ Breech _____
- J Air shutter setting _____ Locked _____
- K Measure static pressure in duct system:
Supply side static pressure _____
Return side static pressure _____
Static pressure drop _____
- L Temperature rise after steady state conditions have been achieved: Supply side _____ Return side _____
- M Block off return air (limit control checkout); confirm burner shut down within 2 to 3 minutes _____

Owner Record

Installed by: _____

Dealer: _____

Address _____

Telephone No. () _____

License No. _____

Notes: _____