

**PRODUCT SPECIFICATIONS**



**UP TO 14 SEER**

**R-410A**

**COOLING CAPACITY: 18,000 - 60,000 BTU/H**

**HEATING CAPACITY: 18,000 - 59,000 BTU/H**

**SPLIT SYSTEM HEAT PUMP**

The Amana<sup>®</sup> brand ASZ14 Heat Pump uses the chlorine-free refrigerant R-410A and features operating sound levels that are among the best in the heating and cooling industry. Our quality manufacturing and easy installation and maintenance make this unit one of the best values on the market.

**Standard Features**

- R-410A chlorine-free refrigerant
- High-efficiency Copeland<sup>®</sup> scroll compressor
- High-density foam compressor sound blanket
- Copeland ComfortAlert diagnostics
- High- and low-pressure switches
- Factory-installed bi-flow liquid-line filter dryer
- Liquid refrigerant return protection
- Two-speed condenser fan motor
- Copper tube/enhanced aluminum fin coil
- Sweat connection service valves with easy access to gauge ports
- AHRI Certified; ETL Listed

**Cabinet Features**

- Amana brand sound control top design
- Wire fan discharge grille
- Steel louver coil guard
- Baked-on powder-paint finish
- Rust-resistant screws
- Compact footprint
- Top and side maintenance access
- Single-panel access to controls with space provided for field-installed accessories
- When properly anchored, meets the 2001 Florida Building Code unit integrity requirements for hurricane-type winds (Anchor bracket kits available.)

**Contents**

Nomenclature.....2  
 Product Specifications.....3  
 Expanded Cooling Data .....4  
 Expanded Heating Data.....18  
 AHRI Performance Ratings.....20  
 Dimensions.....25  
 Wiring Diagram .....26  
 Accessories .....27



\* To receive the Lifetime Unit Replacement Limited Warranty and 10-Year Parts Limited Warranty, online registration must be completed within 60 days of installation. Online registration is not required in California or Québec. Full warranty details are available at [www.amana-hac.com](http://www.amana-hac.com).

**NOMENCLATURE**

	<b>A</b>	<b>S</b>	<b>Z</b>	<b>14</b>	<b>036</b>	<b>1</b>	<b>AA</b>
	<b>1</b>	<b>2</b>	<b>3</b>	<b>4,5</b>	<b>6,7,8</b>	<b>9</b>	<b>10,11</b>
<b>Brand</b>	A Amana® Brand						<b>Engineering *</b> Major/ Minor Revisions * Neither revision is used for order entry or inventory management.
<b>Product Category</b>	S Split System						
<b>Unit Type</b>	C Condenser R-22	X Condenser R-410A	H Heat Pump R-22	Z Heat Pump R-410A			<b>Electrical</b>
						1 208/230 V, 1 Phase, 60 Hz	2 220/240 V, 1 Phase, 50 Hz
						3 208/230 V, 3 Phase, 60 Hz	4 460 V, 3 Phase, 60 Hz
						5 380/415 V, 3 Phase, 50 Hz	
<b>Efficiency</b>	13 13 SEER	14 14 SEER	16 16 SEER	18 18 SEER			<b>Nominal Capacity</b>
					018 1½ Tons	048 4 Tons	024 2 Tons
					030 2½ Tons	090 7½ tons	060 5 Tons
					036 3 Tons	120 10 Tons	042 3½ Tons

**Important EnergyStar Notice:** EnergyStar ratings are dependent upon conditions beyond equipment installation. Proper sizing and installation of equipment is critical to achieve optimal performance. Split system air conditioners and heat pumps must be matched with appropriate coil components to meet EnergyStar criteria. Ask your contractor for details or visit [www.energystar.gov](http://www.energystar.gov).

**SPECIFICATIONS**

	<b>ASZ14 0181A</b>	<b>ASZ14 0241A</b>	<b>ASZ14 0301A</b>	<b>ASZ14 0361A</b>	<b>ASZ14 0421A</b>	<b>ASZ14 0481A</b>	<b>ASZ14 0601A</b>
<b>Capacities and Ratings</b>							
Nominal Cooling (BTU/h)	18,000	24,000	30,000	36,000	42,000	48,000	60,000
Nominal Heating (BTU/h)	18,000	24,000	28,000	36,000	42,000	46,600	59,000
Decibels	70	72	72	73	73	74	75
<b>Compressor</b>							
RLA	9.0	12.8	14.1	16.7	17.9	19.9	26.4
LRA	48.0	58.3	73.0	79.0	112.0	109.0	134.0
<b>Condenser Fan Motor</b>							
Horsepower	1/12	1/6	1/6	¼	¼	¼	¼
FLA	0.6	0.9	1.10	1.5	1.5	1.5	1.5
LRA	1.0	1.5	1.9	3.1	3.1	3.1	3.1
<b>Refrigeration System</b>							
Refrigerant Line Size <sup>1</sup>							
Liquid Line Size ("O.D.)	¾"	¾"	¾"	¾"	¾"	¾"	¾"
Suction Line Size ("O.D.)	¾"	¾"	¾"	7/8"	1 1/8"	1 1/8"	1 1/8"
Refrigerant Connection Size							
Liquid Valve Size ("O.D.)	¾"	¾"	¾"	¾"	¾"	¾"	¾"
Suction Valve Size ("O.D.)	¾"	¾"	¾"	7/8"	7/8"	7/8"	7/8"
Valve Connection Type	Sweat	Sweat	Sweat	Sweat	Sweat	Sweat	Sweat
Refrigerant Charge	143	163	188	213	213	273	278
<b>Electrical Data</b>							
Volts / Hz / Phase	208/230-60-1			208/230-60-1			
Minimum Circuit Ampacity <sup>2</sup>	11.8	16.9	18.7	22.4	23.9	26.4	34.5
Max. Overcurrent Protection <sup>3</sup>	20	30	30	30	40	40	60
Min / Max Volts	197 / 253	197 / 253	197 / 253	197 / 253	197 / 253	197 / 253	197 / 253
Electrical Conduit Size	½" or ¾"	½" or ¾"	½" or ¾"	½" or ¾"	½" or ¾"	½" or ¾"	½" or ¾"
Low Voltage	½"	½"	½"	½"	½"	½"	½"
<b>Ship Weight (lbs)</b>	199	207	219	242	242	266	280

<sup>1</sup> Tested and rated in accordance with AHRI Standard 210/240

<sup>2</sup> Wire size should be determined in accordance with National Electrical Codes; extensive wire runs will require larger wire sizes

<sup>3</sup> Must use time-delay fuses or HACR-type circuit breakers of the same size as noted.

**Notes**

- Always check the S&R plate for electrical data on the unit being installed.
- Installer will need to supply 7/8" to 1 1/8" adapters for suction line connections.
- Unit is charged with refrigerant for 15' of 3/8" liquid line. System charge must be adjusted per Installation Instructions Final Charge Procedure.
- Installation of these units requires the specified TXV Kit to be installed on the indoor coil. THE SPECIFIED TXV IS DETERMINED BY THE OUTDOOR UNIT NOT THE INDOOR COIL.

EXPANDED COOLING DATA — MODEL: ASZ140181A\* / CA\*F3131\*6A\* +TXV / MBR800\*\* -1

IDB	Airflow	Outdoor Ambient Temperature																							
		65°F				75°F				85°F				95°F				105°F				115°F			
		59	63	67	71	59	63	67	71	59	63	67	71	59	63	67	71	59	63	67	71	59	63	67	71
70	MBh	17.6	18.3	20.0	-	17.2	17.9	19.6	-	16.8	17.4	19.1	-	16.4	17.0	18.6	-	15.6	16.2	17.7	-	14.4	15.0	16.4	-
	S/T	0.74	0.62	0.43	-	0.76	0.64	0.44	-	0.78	0.65	0.45	-	0.81	0.67	0.47	-	0.84	0.70	0.49	-	0.85	0.71	0.49	-
	ΔT	18	15	12	-	18	16	12	-	18	16	12	-	18	16	12	-	18	15	12	-	17	14	11	-
	KW	1.17	1.19	1.23	-	1.25	1.28	1.32	-	1.33	1.36	1.40	-	1.40	1.43	1.47	-	1.45	1.48	1.53	-	1.50	1.53	1.58	-
	Amps	4.2	4.3	4.4	-	4.5	4.6	4.8	-	4.9	5.0	5.2	-	5.3	5.4	5.6	-	5.6	5.7	5.9	-	5.9	6.1	6.3	-
	Hi PR	213	229	242	-	239	257	271	-	271	292	308	-	309	333	351	-	348	374	395	-	384	413	436	-
	Lo PR	107	113	124	-	113	120	131	-	117	124	136	-	123	131	143	-	129	137	150	-	133	142	155	-
	MBh	17.1	17.7	19.4	-	16.7	17.3	19.0	-	16.3	16.9	18.5	-	15.9	16.5	18.1	-	15.1	15.7	17.2	-	14.0	14.5	15.9	-
	S/T	0.70	0.59	0.41	-	0.73	0.61	0.42	-	0.75	0.62	0.43	-	0.77	0.64	0.45	-	0.80	0.67	0.46	-	0.81	0.67	0.47	-
	ΔT	18	16	12	-	19	16	12	-	19	16	12	-	19	16	12	-	19	16	12	-	17	15	11	-
KW	1.16	1.18	1.22	-	1.24	1.27	1.31	-	1.32	1.35	1.39	-	1.38	1.41	1.46	-	1.44	1.47	1.52	-	1.49	1.52	1.57	-	
Amps	4.2	4.3	4.4	-	4.5	4.6	4.8	-	4.9	5.0	5.2	-	5.2	5.3	5.5	-	5.5	5.7	5.9	-	5.9	6.0	6.2	-	
Hi PR	210	227	239	-	236	254	268	-	269	289	305	-	306	329	348	-	344	370	391	-	380	409	432	-	
Lo PR	105	112	122	-	111	119	129	-	116	123	134	-	122	129	141	-	127	136	148	-	132	140	153	-	
MBh	15.8	16.4	17.9	-	15.4	16.0	17.5	-	15.1	15.6	17.1	-	14.7	15.2	16.7	-	14.0	14.5	15.9	-	12.9	13.4	14.7	-	
S/T	0.68	0.57	0.39	-	0.70	0.59	0.41	-	0.72	0.60	0.42	-	0.74	0.62	0.43	-	0.77	0.64	0.45	-	0.78	0.65	0.45	-	
ΔT	19	16	12	-	19	16	12	-	19	16	12	-	19	17	13	-	19	16	12	-	18	15	12	-	
KW	1.13	1.15	1.19	-	1.21	1.24	1.28	-	1.29	1.31	1.35	-	1.35	1.38	1.42	-	1.41	1.44	1.48	-	1.45	1.48	1.53	-	
Amps	4.1	4.2	4.3	-	4.4	4.5	4.6	-	4.7	4.9	5.0	-	5.1	5.2	5.4	-	5.4	5.5	5.7	-	5.7	5.8	6.0	-	
Hi PR	204	220	232	-	229	247	260	-	261	280	296	-	297	319	337	-	334	359	379	-	369	397	419	-	
Lo PR	102	109	119	-	108	115	126	-	112	119	130	-	118	126	137	-	124	132	144	-	128	136	149	-	

75	MBh	17.9	18.5	20.0	21.5	17.5	18.0	19.5	21.0	17.1	17.6	19.1	20.5	16.7	17.2	18.6	20.0	15.9	16.3	17.7	19.0	14.7	15.1	16.4	17.6
	S/T	0.84	0.75	0.57	0.36	0.87	0.78	0.59	0.38	0.89	0.80	0.60	0.39	0.92	0.82	0.62	0.40	0.95	0.85	0.65	0.42	0.96	0.86	0.65	0.42
	ΔT	20	19	15	11	21	19	16	11	21	19	16	11	21	19	16	11	21	19	16	11	19	18	15	10
	KW	1.18	1.20	1.24	1.27	1.26	1.29	1.33	1.37	1.34	1.37	1.41	1.46	1.41	1.44	1.48	1.53	1.46	1.50	1.54	1.59	1.51	1.55	1.60	1.65
	Amps	4.2	4.3	4.5	4.6	4.6	4.7	4.8	5.0	5.0	5.1	5.2	5.4	5.3	5.4	5.6	5.8	5.6	5.8	6.0	6.2	6.0	6.1	6.3	6.5
	Hi PR	215	231	244	255	241	259	274	286	274	295	311	325	312	336	355	370	351	378	399	416	388	418	441	460
	Lo PR	108	114	125	133	114	121	132	141	118	126	137	146	124	132	144	154	130	138	151	161	135	143	156	166
	MBh	17.4	17.9	19.4	20.8	17.0	17.5	19.0	20.3	16.6	17.1	18.5	19.9	16.2	16.7	18.1	19.4	15.4	15.8	17.2	18.4	14.3	14.7	15.9	17.1
	S/T	0.80	0.71	0.54	0.35	0.83	0.74	0.56	0.36	0.85	0.76	0.57	0.37	0.88	0.78	0.59	0.38	0.91	0.81	0.62	0.40	0.92	0.82	0.62	0.40
	ΔT	21	20	16	11	22	20	16	11	22	20	16	11	22	20	16	11	22	20	16	11	20	18	15	10
KW	1.17	1.19	1.23	1.26	1.25	1.28	1.32	1.36	1.33	1.36	1.40	1.44	1.40	1.43	1.47	1.52	1.45	1.48	1.53	1.58	1.50	1.53	1.58	1.64	
Amps	4.2	4.3	4.4	4.6	4.5	4.6	4.8	5.0	4.9	5.0	5.2	5.4	5.3	5.4	5.6	5.8	5.6	5.7	5.9	6.1	5.9	6.1	6.3	6.5	
Hi PR	213	229	242	252	239	257	271	283	271	292	308	322	309	333	351	366	348	374	395	412	384	413	437	455	
Lo PR	107	113	124	132	113	120	131	139	117	124	136	145	123	131	143	152	129	137	150	159	133	142	155	165	
MBh	16.1	16.5	17.9	19.2	15.7	16.2	17.5	18.8	15.3	15.8	17.1	18.3	15.0	15.4	16.7	17.9	14.2	14.6	15.8	17.0	13.2	13.5	14.7	15.7	
S/T	0.77	0.69	0.52	0.34	0.80	0.71	0.54	0.35	0.82	0.73	0.55	0.36	0.84	0.76	0.57	0.37	0.88	0.78	0.59	0.38	0.88	0.79	0.60	0.39	
ΔT	22	20	16	11	22	20	17	11	22	20	17	11	22	20	17	12	22	20	16	11	20	19	15	11	
KW	1.14	1.16	1.20	1.24	1.22	1.25	1.29	1.33	1.30	1.32	1.37	1.41	1.36	1.39	1.44	1.48	1.42	1.45	1.49	1.54	1.47	1.50	1.54	1.60	
Amps	4.1	4.2	4.3	4.5	4.4	4.5	4.7	4.8	4.8	4.9	5.1	5.2	5.1	5.2	5.4	5.6	5.4	5.6	5.7	6.0	5.7	5.9	6.1	6.3	
Hi PR	206	222	234	244	231	249	263	274	263	283	299	312	300	323	341	355	337	363	383	400	373	401	423	442	
Lo PR	103	110	120	128	109	116	127	135	113	121	132	140	119	127	138	147	125	133	145	155	129	137	150	160	

IDB: Entering Indoor Dry Bulb Temperature  
 Shaded area reflects ACCA (TVA) conditions  
 kW=Total system power  
 Design Subcooling 9 ±3 °F @ the liquid service valve, AHRI 95 test conditions  
 Amps = outdoor unit amps (comp. +fan)

EXPANDED COOLING DATA — MODEL: ASZ140181A\* / CA\*F3131\*6A\* +TXV / MBR800\*\* -1 (CONT.)

IDB*	Airflow	Outdoor Ambient Temperature																							
		65°F				75°F				85°F				95°F				105°F				115°F			
		59	63	67	71	59	63	67	71	59	63	67	71	59	63	67	71	59	63	67	71	59	63	67	71
80	MBh	18.3	18.7	19.9	21.3	17.8	18.2	19.5	20.8	17.4	17.8	19.0	20.3	17.0	17.4	18.5	19.8	16.1	16.5	17.6	18.8	14.9	15.3	16.3	17.4
	S/T	0.92	0.86	0.70	0.52	0.95	0.89	0.73	0.54	1.00	0.92	0.75	0.56	1.00	0.94	0.77	0.57	1.00	1.00	0.80	0.60	1.00	1.00	0.80	0.60
	ΔT	23	22	19	15	24	22	19	15	23	22	19	15	23	22	19	16	22	21	18	15	20	21	18	14
	KW	1.19	1.21	1.25	1.28	1.27	1.30	1.34	1.38	1.35	1.38	1.42	1.47	1.42	1.45	1.50	1.54	1.48	1.51	1.56	1.61	1.53	1.56	1.61	1.66
	Amps	4.3	4.4	4.5	4.7	4.6	4.7	4.9	5.1	5.0	5.1	5.3	5.5	5.3	5.5	5.7	5.9	5.7	5.8	6.0	6.2	6.0	6.2	6.4	6.6
	Hi PR	217	233	247	257	243	262	277	288	277	298	315	328	315	339	358	374	355	382	403	420	392	422	445	465
	Lo PR	109	116	126	134	115	122	133	142	119	127	139	148	125	133	146	155	131	140	153	162	136	145	158	168
	MBh	17.7	18.1	19.4	20.7	17.3	17.7	18.9	20.2	16.9	17.3	18.5	19.7	16.5	16.8	18.0	19.2	15.7	16.0	17.1	18.3	14.5	14.8	15.8	16.9
	S/T	0.88	0.82	0.67	0.50	0.91	0.85	0.69	0.52	0.93	0.87	0.71	0.53	0.96	0.90	0.73	0.55	1.00	0.94	0.76	0.57	1.00	0.94	0.77	0.57
	ΔT	24	23	20	16	24	23	20	16	24	23	20	16	24	23	20	16	24	23	20	16	22	21	19	15
KW	1.18	1.20	1.24	1.27	1.26	1.29	1.33	1.37	1.34	1.37	1.41	1.46	1.41	1.44	1.48	1.53	1.46	1.50	1.54	1.59	1.51	1.55	1.60	1.65	
Amps	4.2	4.3	4.5	4.6	4.6	4.7	4.8	5.0	5.0	5.1	5.3	5.4	5.3	5.4	5.6	5.8	5.6	5.8	6.0	6.2	6.0	6.1	6.3	6.5	
Hi PR	215	231	244	255	241	259	274	286	274	295	311	325	312	336	355	370	351	378	399	416	388	418	441	460	
Lo PR	108	114	125	133	114	121	132	141	118	126	137	146	124	132	144	154	130	138	151	161	135	143	156	166	
MBh	16.4	16.7	17.9	19.1	16.0	16.3	17.4	18.6	15.6	15.9	17.0	18.2	15.2	15.6	16.6	17.8	14.5	14.8	15.8	16.9	13.4	13.7	14.6	15.6	
S/T	0.84	0.79	0.64	0.48	0.88	0.82	0.67	0.50	0.90	0.84	0.69	0.51	0.93	0.87	0.71	0.53	0.96	0.90	0.73	0.55	0.97	0.91	0.74	0.55	
ΔT	24	23	20	16	24	23	20	16	25	23	20	16	25	24	21	16	24	23	20	16	23	22	19	15	
KW	1.15	1.17	1.21	1.24	1.23	1.26	1.30	1.34	1.31	1.34	1.38	1.42	1.37	1.40	1.45	1.49	1.43	1.46	1.51	1.56	1.48	1.51	1.56	1.61	
Amps	4.1	4.2	4.4	4.5	4.5	4.6	4.7	4.9	4.8	4.9	5.1	5.3	5.2	5.3	5.5	5.7	5.5	5.6	5.8	6.0	5.8	5.9	6.1	6.4	
Hi PR	208	224	237	247	234	252	266	277	266	286	302	315	303	326	344	359	341	367	387	404	376	405	428	446	
Lo PR	104	111	121	129	110	117	128	136	115	122	133	142	120	128	140	149	126	134	147	156	131	139	152	161	

85	MBh	18.6	18.9	19.8	21.2	18.1	18.5	19.4	20.7	17.7	18.1	18.9	20.2	17.3	17.6	18.4	19.7	16.4	16.7	17.5	18.7	15.2	15.5	16.2	17.3
	S/T	0.96	0.93	0.84	0.68	1.00	0.96	0.87	0.71	1.00	0.99	0.89	0.72	1.00	1.00	0.92	0.75	1.00	1.00	0.95	0.77	1.00	1.00	0.96	0.78
	ΔT	24	24	23	20	25	24	23	20	24	24	23	20	24	24	23	20	22	23	23	20	21	21	21	18
	KW	1.19	1.22	1.26	1.29	1.28	1.31	1.35	1.39	1.36	1.39	1.43	1.48	1.43	1.46	1.51	1.56	1.49	1.52	1.57	1.62	1.54	1.57	1.62	1.68
	Amps	4.3	4.4	4.6	4.7	4.7	4.8	4.9	5.1	5.1	5.2	5.3	5.5	5.4	5.5	5.7	5.9	5.7	5.9	6.1	6.3	6.1	6.2	6.4	6.7
	Hi PR	219	236	249	260	246	265	279	291	280	301	318	331	318	343	362	377	358	386	407	425	396	426	450	469
	Lo PR	110	117	127	136	116	123	135	143	121	128	140	149	127	135	147	157	133	141	154	164	137	146	159	170
	MBh	18.0	18.4	19.3	20.5	17.6	18.0	18.8	20.1	17.2	17.5	18.4	19.6	16.8	17.1	17.9	19.1	15.9	16.2	17.0	18.2	14.8	15.0	15.8	16.8
	S/T	0.92	0.89	0.80	0.65	0.95	0.92	0.83	0.67	0.98	0.94	0.85	0.69	1.00	0.97	0.88	0.71	1.00	1.00	0.91	0.74	1.00	1.00	0.92	0.74
	ΔT	25	25	24	20	26	25	24	21	26	25	24	21	26	25	24	21	24	25	24	21	23	23	22	19
KW	1.19	1.21	1.25	1.28	1.27	1.30	1.34	1.38	1.35	1.38	1.42	1.47	1.42	1.45	1.50	1.54	1.48	1.51	1.56	1.61	1.53	1.56	1.61	1.66	
Amps	4.3	4.4	4.5	4.7	4.6	4.7	4.9	5.1	5.0	5.1	5.3	5.5	5.3	5.5	5.7	5.9	5.7	5.8	6.0	6.2	6.0	6.2	6.4	6.6	
Hi PR	217	233	247	257	243	262	277	288	277	298	315	328	315	339	358	374	355	382	403	420	392	422	445	465	
Lo PR	109	116	126	134	115	122	133	142	119	127	139	148	125	133	146	155	131	140	153	162	136	145	158	168	
MBh	16.6	17.0	17.8	19.0	16.3	16.6	17.4	18.5	15.9	16.2	16.9	18.1	15.5	15.8	16.5	17.6	14.7	15.0	15.7	16.8	13.6	13.9	14.5	15.5	
S/T	0.89	0.85	0.77	0.63	0.92	0.89	0.80	0.65	0.94	0.91	0.82	0.66	0.97	0.94	0.85	0.69	1.00	0.97	0.88	0.71	1.00	0.98	0.89	0.72	
ΔT	26	25	24	21	26	26	24	21	26	26	24	21	26	26	24	21	26	26	24	21	24	24	23	20	
KW	1.16	1.18	1.22	1.25	1.24	1.27	1.31	1.35	1.32	1.35	1.39	1.43	1.38	1.41	1.46	1.51	1.44	1.47	1.52	1.57	1.49	1.52	1.57	1.62	
Amps	4.2	4.3	4.4	4.6	4.5	4.6	4.8	4.9	4.9	5.0	5.2	5.3	5.2	5.3	5.5	5.7	5.5	5.7	5.8	6.1	5.9	6.0	6.2	6.4	
Hi PR	210	226	239	249	236	254	268	280	269	289	305	318	306	329	348	362	344	370	391	408	380	409	432	451	
Lo PR	105	112	122	130	111	118	129	138	116	123	134	143	122	129	141	150	127	136	148	158	132	140	153	163	

IDB: Entering Indoor Dry Bulb Temperature  
 Shaded area reflects AHR1 conditions  
 kW=Total system power  
 Design Subcooling 9 ±3 °F @ the liquid service valve, AHR1 95 test conditions  
 Amps = outdoor unit amps (comp. +fan)

EXPANDED COOLING DATA — MODEL: ASZ140241A\* / CA\*F3636\*6A\*+TXV / MBR800\*\* -1

IDB*	Airflow	Outdoor Ambient Temperature																							
		65°F				75°F				85°F				95°F				105°F				115°F			
		59	63	67	71	59	63	67	71	59	63	67	71	59	63	67	71	59	63	67	71	59	63	67	71
70	MBh	23.5	24.4	26.7	-	23.0	23.8	26.1	-	22.4	23.2	25.5	-	21.9	22.7	24.8	-	20.8	21.5	23.6	-	19.3	20.0	21.9	-
	S/T	0.75	0.63	0.44	-	0.78	0.65	0.45	-	0.80	0.67	0.46	-	0.83	0.69	0.48	-	0.86	0.72	0.50	-	0.87	0.72	0.50	-
	ΔT	17	15	11	-	17	15	11	-	17	15	11	-	17	15	11	-	17	15	11	-	16	14	11	-
	KW	1.65	1.68	1.73	-	1.77	1.80	1.86	-	1.87	1.91	1.97	-	1.97	2.01	2.07	-	2.04	2.09	2.15	-	2.11	2.14	2.22	-
	Amps	10.1	10.2	10.4	-	10.5	10.7	10.9	-	11.0	11.2	11.4	-	11.5	11.7	11.9	-	12.0	12.2	12.4	-	12.4	12.6	12.9	-
	Hi PR	222	239	252	-	249	268	283	-	283	305	322	-	323	347	367	-	363	391	412	-	401	432	456	-
	Lo PR	110	117	128	-	116	124	135	-	121	129	140	-	127	135	147	-	133	142	155	-	138	146	160	-
	MBh	22.8	23.7	25.9	-	22.3	23.1	25.3	-	21.8	22.6	24.7	-	21.2	22.0	24.1	-	20.2	20.9	22.9	-	18.7	19.4	21.2	-
	S/T	0.72	0.60	0.42	-	0.74	0.62	0.43	-	0.76	0.64	0.44	-	0.79	0.66	0.46	-	0.82	0.68	0.47	-	0.83	0.69	0.48	-
	ΔT	18	15	12	-	18	16	12	-	18	16	12	-	18	16	12	-	18	15	12	-	17	14	11	-
	KW	1.64	1.67	1.72	-	1.75	1.79	1.84	-	1.86	1.90	1.95	-	1.95	1.99	2.05	-	2.03	2.07	2.14	-	2.09	2.14	2.21	-
	Amps	10.0	10.1	10.3	-	10.5	10.6	10.8	-	11.0	11.1	11.4	-	11.4	11.6	11.9	-	11.9	12.1	12.3	-	12.3	12.5	12.8	-
Hi PR	220	236	250	-	247	265	280	-	280	302	319	-	319	344	363	-	359	387	408	-	397	427	451	-	
Lo PR	109	116	127	-	115	122	134	-	120	127	139	-	126	134	146	-	132	140	153	-	136	145	158	-	
MBh	21.1	21.8	23.9	-	20.6	21.3	23.4	-	20.1	20.8	22.8	-	19.6	20.3	22.3	-	18.6	19.3	21.1	-	17.3	17.9	19.6	-	
S/T	0.69	0.58	0.40	-	0.72	0.60	0.42	-	0.74	0.62	0.43	-	0.76	0.63	0.44	-	0.79	0.66	0.46	-	0.80	0.66	0.46	-	
ΔT	18	16	12	-	18	16	12	-	18	16	12	-	18	16	12	-	18	16	12	-	17	15	11	-	
KW	1.60	1.63	1.68	-	1.72	1.75	1.80	-	1.82	1.85	1.91	-	1.90	1.94	2.00	-	1.98	2.02	2.08	-	2.04	2.09	2.15	-	
Amps	9.8	10.0	10.2	-	10.3	10.4	10.6	-	10.8	11.0	11.2	-	11.2	11.4	11.7	-	11.7	11.9	12.1	-	12.1	12.3	12.6	-	
Hi PR	213	229	242	-	239	257	272	-	272	293	309	-	310	333	352	-	349	375	396	-	385	414	438	-	
Lo PR	106	112	123	-	112	119	130	-	116	123	135	-	122	130	142	-	128	136	148	-	132	141	153	-	
75	MBh	23.9	24.6	26.7	28.6	23.4	24.1	26.0	27.9	22.8	23.5	25.4	27.3	22.2	22.9	24.8	26.6	21.1	21.8	23.6	25.3	19.6	20.2	21.8	23.4
	S/T	0.86	0.77	0.58	0.37	0.89	0.79	0.60	0.39	0.91	0.81	0.62	0.40	0.94	0.84	0.64	0.41	0.98	0.87	0.66	0.42	0.98	0.88	0.67	0.43
	ΔT	20	18	15	10	20	18	15	10	20	18	15	10	20	19	15	10	20	18	15	10	19	17	14	10
	KW	1.66	1.70	1.75	1.80	1.78	1.82	1.87	1.93	1.89	1.93	1.99	2.05	1.98	2.02	2.09	2.15	2.06	2.10	2.17	2.24	2.13	2.17	2.24	2.32
	Amps	10.1	10.2	10.4	10.7	10.6	10.7	10.9	11.2	11.1	11.3	11.5	11.8	11.6	11.8	12.0	12.3	12.0	12.2	12.5	12.8	12.5	12.7	13.0	13.3
	Hi PR	224	241	255	266	252	271	286	298	286	308	325	339	326	351	370	386	367	395	417	435	405	436	460	480
	Lo PR	111	118	129	138	117	125	136	145	122	130	142	151	128	136	149	159	134	143	156	166	139	148	161	172
	MBh	23.2	23.9	25.9	27.8	22.7	23.4	25.3	27.1	22.1	22.8	24.7	26.5	21.6	22.2	24.1	25.8	20.5	21.1	22.9	24.5	19.0	19.6	21.2	22.7
	S/T	0.82	0.73	0.55	0.36	0.85	0.76	0.57	0.37	0.87	0.78	0.59	0.38	0.90	0.80	0.61	0.39	0.93	0.83	0.63	0.41	0.94	0.84	0.63	0.41
	ΔT	21	19	15	11	21	19	16	11	21	19	16	11	21	19	16	11	21	19	16	11	19	18	15	10
	KW	1.65	1.68	1.73	1.78	1.77	1.80	1.86	1.92	1.87	1.91	1.97	2.03	1.97	2.01	2.07	2.13	2.04	2.09	2.15	2.22	2.11	2.16	2.22	2.30
	Amps	10.1	10.2	10.4	10.6	10.5	10.7	10.9	11.1	11.0	11.2	11.4	11.7	11.5	11.7	11.9	12.2	12.0	12.2	12.4	12.7	12.4	12.6	12.9	13.2
Hi PR	222	239	252	263	249	268	283	295	283	305	322	336	323	347	367	382	363	391	412	430	401	432	456	475	
Lo PR	110	117	128	136	116	124	135	144	121	129	140	150	127	135	147	157	133	142	155	165	138	146	160	170	
MBh	21.4	22.1	23.9	25.6	20.9	21.6	23.3	25.0	20.4	21.0	22.8	24.4	19.9	20.5	22.2	23.8	18.9	19.5	21.1	22.7	17.5	18.1	19.6	21.0	
S/T	0.79	0.70	0.53	0.34	0.82	0.73	0.55	0.36	0.84	0.75	0.57	0.36	0.86	0.77	0.58	0.38	0.90	0.80	0.61	0.39	0.90	0.81	0.61	0.39	
ΔT	21	19	16	11	21	19	16	11	21	19	16	11	21	20	16	11	21	19	16	11	20	18	15	10	
KW	1.61	1.64	1.69	1.74	1.73	1.76	1.82	1.87	1.83	1.87	1.92	1.98	1.92	1.96	2.02	2.08	2.00	2.04	2.10	2.17	2.06	2.10	2.17	2.24	
Amps	9.9	10.0	10.2	10.4	10.3	10.5	10.7	10.9	10.9	11.0	11.2	11.5	11.3	11.5	11.7	12.0	11.8	11.9	12.2	12.5	12.2	12.4	12.7	13.0	
Hi PR	215	232	245	255	242	260	275	286	275	296	312	326	313	337	356	371	352	379	400	417	389	419	442	461	
Lo PR	107	114	124	132	113	120	131	140	117	125	136	145	123	131	143	152	129	137	150	160	133	142	155	165	

IDB: Entering Indoor Dry Bulb Temperature  
 Shaded area reflects ACCA (TVA) conditions  
 kW=Total system power  
 Design Subcooling 9 ±3 °F @ the liquid service valve, AHRI 95 test conditions  
 Amps = outdoor unit amps (comp.+fan)

EXPANDED COOLING DATA — MODEL: ASZ140241A\* / CA\*F3636\*6A\*+TXV / MBR800\*\* -1 (CONT.)

IDB*	Airflow	Outdoor Ambient Temperature																							
		65°F				75°F				85°F				95°F				105°F				115°F			
		59	63	67	71	59	63	67	71	59	63	67	71	59	63	67	71	59	63	67	71	59	63	67	71
80	MBh	24.3	24.9	26.6	28.4	23.8	24.3	26.0	27.7	23.2	23.7	25.3	27.1	22.6	23.1	24.7	26.4	21.5	22.0	23.5	25.1	19.9	20.4	21.8	23.3
	S/T	0.94	0.88	0.72	0.54	1.00	0.91	0.74	0.56	1.00	0.94	0.76	0.57	1.00	0.97	0.79	0.59	1.00	1.00	0.82	0.61	1.00	1.00	0.82	0.62
	ΔT	22	21	18	15	23	21	19	15	22	21	19	15	22	21	19	15	22	21	18	15	19	20	17	14
	kW	1.67	1.71	1.76	1.81	1.80	1.83	1.89	1.95	1.90	1.94	2.00	2.06	2.00	2.04	2.10	2.17	2.08	2.12	2.19	2.26	2.15	2.19	2.26	2.33
	Amps	10.2	10.3	10.5	10.7	10.6	10.8	11.0	11.2	11.2	11.3	11.6	11.8	11.6	11.8	12.1	12.4	12.1	12.3	12.6	12.9	12.6	12.8	13.1	13.4
	Hi PR	226	244	257	268	254	273	289	301	289	311	328	343	329	354	374	390	370	399	421	439	409	440	465	485
	Lo PR	112	119	130	139	119	126	138	147	123	131	143	153	130	138	150	160	136	144	158	168	140	149	163	174
	MBh	23.6	24.1	25.8	27.6	23.1	23.6	25.2	26.9	22.5	23.0	24.6	26.3	22.0	22.5	24.0	25.7	20.9	21.3	22.8	24.4	19.3	19.8	21.1	22.6
	S/T	0.90	0.84	0.68	0.51	0.93	0.87	0.71	0.53	0.95	0.89	0.73	0.54	0.98	0.92	0.75	0.56	1.00	0.96	0.78	0.58	1.00	0.96	0.79	0.59
	ΔT	23	22	19	15	23	22	19	15	23	22	19	15	23	22	19	16	23	22	19	15	21	21	18	14
	kW	1.66	1.70	1.75	1.80	1.78	1.82	1.87	1.93	1.89	1.93	1.99	2.05	1.98	2.02	2.09	2.15	2.06	2.10	2.17	2.24	2.13	2.17	2.24	2.32
	Amps	10.1	10.2	10.4	10.7	10.6	10.7	10.9	11.2	11.1	11.3	11.5	11.8	11.6	11.8	12.0	12.3	12.0	12.2	12.5	12.8	12.5	12.7	13.0	13.3
Hi PR	224	241	255	266	252	271	286	298	286	308	325	339	326	351	370	386	367	395	417	435	405	436	460	480	
Lo PR	111	118	129	138	117	125	136	145	122	130	142	151	128	136	149	159	134	143	156	166	139	148	161	172	
MBh	21.8	22.3	23.8	25.5	21.3	21.8	23.3	24.9	20.8	21.3	22.7	24.3	20.3	20.7	22.2	23.7	19.3	19.7	21.0	22.5	17.9	18.2	19.5	20.8	
S/T	0.86	0.81	0.66	0.49	0.90	0.84	0.68	0.51	0.92	0.86	0.70	0.52	0.95	0.89	0.72	0.54	0.98	0.92	0.75	0.56	0.99	0.93	0.76	0.57	
ΔT	23	22	19	16	24	23	20	16	24	23	20	16	24	23	20	16	24	23	20	16	22	21	18	15	
kW	1.63	1.66	1.71	1.76	1.74	1.78	1.83	1.89	1.84	1.88	1.94	2.00	1.93	1.97	2.04	2.10	2.01	2.05	2.12	2.19	2.08	2.12	2.19	2.26	
Amps	9.9	10.1	10.3	10.5	10.4	10.5	10.7	11.0	10.9	11.1	11.3	11.6	11.4	11.5	11.8	12.1	11.8	12.0	12.3	12.6	12.3	12.5	12.7	13.1	
Hi PR	217	234	247	258	244	263	277	289	278	299	315	329	316	340	359	375	356	383	404	422	393	423	447	466	
Lo PR	108	115	125	133	114	121	132	141	118	126	138	146	124	132	144	154	130	139	151	161	135	143	157	167	
85	MBh	24.8	25.2	26.4	28.2	24.2	24.7	25.8	27.6	23.6	24.1	25.2	26.9	23.0	23.5	24.6	26.2	21.9	22.3	23.4	24.9	20.3	20.7	21.6	23.1
	S/T	0.98	0.95	0.86	0.70	1.00	0.98	0.89	0.72	1.00	1.00	0.91	0.74	1.00	1.00	0.94	0.76	1.00	1.00	0.98	0.79	1.00	1.00	0.98	0.80
	ΔT	23	23	22	19	23	23	22	19	23	23	22	19	22	23	22	19	21	21	22	19	19	20	20	18
	kW	1.69	1.72	1.77	1.83	1.81	1.85	1.90	1.96	1.92	1.96	2.02	2.08	2.01	2.05	2.12	2.19	2.09	2.14	2.21	2.28	2.16	2.21	2.28	2.35
	Amps	10.2	10.3	10.5	10.8	10.7	10.8	11.1	11.3	11.2	11.4	11.6	11.9	11.7	11.9	12.1	12.4	12.2	12.4	12.6	13.0	12.7	12.9	13.1	13.5
	Hi PR	229	246	260	271	257	276	292	304	292	314	332	346	332	358	378	394	374	402	425	443	413	445	470	490
	Lo PR	113	121	132	140	120	127	139	148	125	132	145	154	131	139	152	162	137	146	159	170	142	151	165	175
	MBh	24.0	24.5	25.7	27.4	23.5	23.9	25.1	26.8	22.9	23.4	24.5	26.1	22.4	22.8	23.9	25.5	21.2	21.7	22.7	24.2	19.7	20.1	21.0	22.4
	S/T	0.94	0.91	0.82	0.66	0.97	0.94	0.85	0.69	1.00	0.96	0.87	0.71	1.00	0.99	0.90	0.73	1.00	1.00	0.93	0.76	1.00	1.00	0.94	0.76
	ΔT	24	24	23	20	25	24	23	20	25	24	23	20	24	25	23	20	23	23	23	20	21	22	21	18
	kW	1.67	1.71	1.76	1.81	1.80	1.83	1.89	1.95	1.90	1.94	2.00	2.06	2.00	2.04	2.10	2.17	2.08	2.12	2.19	2.26	2.15	2.19	2.26	2.33
	Amps	10.2	10.3	10.5	10.7	10.6	10.8	11.0	11.2	11.2	11.3	11.6	11.8	11.6	11.8	12.1	12.4	12.1	12.3	12.6	12.9	12.6	12.8	13.1	13.4
Hi PR	226	244	257	268	254	273	289	301	289	311	328	343	329	354	374	390	370	399	421	439	409	440	465	485	
Lo PR	112	119	130	139	119	126	138	147	123	131	143	153	130	138	150	160	136	144	158	168	140	149	163	174	
MBh	22.2	22.6	23.7	25.3	21.7	22.1	23.1	24.7	21.2	21.6	22.6	24.1	20.6	21.0	22.0	23.5	19.6	20.0	20.9	22.3	18.2	18.5	19.4	20.7	
S/T	0.91	0.87	0.79	0.64	0.94	0.91	0.82	0.66	0.96	0.93	0.84	0.68	0.99	0.96	0.87	0.70	1.00	0.99	0.90	0.73	1.00	1.00	0.91	0.73	
ΔT	ΔT	24	23	20	25	25	23	20	25	25	23	20	25	25	24	20	24	25	23	20	22	23	22	19	
kW	1.64	1.67	1.72	1.77	1.75	1.79	1.84	1.90	1.86	1.90	1.95	2.02	1.95	1.99	2.05	2.12	2.03	2.07	2.13	2.20	2.09	2.14	2.21	2.28	
Amps	10.0	10.1	10.3	10.5	10.5	10.6	10.8	11.0	11.0	11.1	11.4	11.6	11.4	11.6	11.9	12.1	11.9	12.1	12.3	12.6	12.3	12.5	12.8	13.1	
Hi PR	220	236	250	260	246	265	280	292	280	302	319	332	319	344	363	378	359	387	408	426	397	427	451	470	
Lo PR	109	116	127	135	115	122	134	142	120	127	139	148	126	134	146	155	132	140	153	163	136	145	158	168	

IDB: Entering Indoor Dry Bulb Temperature  
 Shaded area reflects AHRI conditions  
 kW=Total system power  
 Amps = outdoor unit amps (comp. +fan)  
 Design Subcooling 9 ±3 °F @ the liquid service valve, AHRI 95 test conditions

EXPANDED COOLING DATA — MODEL: ASZ140301A\* / CA\*F3642\*6A\*+TXV / MBR1600\*\* -1

IDB*	Airflow	Outdoor Ambient Temperature																							
		65°F				75°F				85°F				95°F				105°F				115°F			
		59	63	67	71	59	63	67	71	59	63	67	71	59	63	67	71	59	63	67	71	59	63	67	71
70	MBh	28.2	29.3	32.0	-	27.6	28.6	31.3	-	26.9	27.9	30.6	-	26.3	27.2	29.8	-	24.9	25.8	28.3	-	23.1	23.9	26.2	-
	S/T	0.79	0.66	0.46	-	0.82	0.68	0.47	-	0.84	0.70	0.48	-	0.86	0.72	0.50	-	0.90	0.75	0.52	-	0.90	0.75	0.52	-
	ΔT	17	15	11	-	17	15	11	-	18	15	11	-	18	15	12	-	17	15	11	-	16	14	11	-
	kW	1.99	2.03	2.09	-	2.13	2.18	2.24	-	2.26	2.30	2.37	-	2.37	2.42	2.49	-	2.46	2.51	2.59	-	2.54	2.59	2.67	-
	Amps	2.3	2.5	2.7	-	2.9	3.0	3.3	-	3.5	3.7	4.0	-	4.1	4.3	4.6	-	4.6	4.8	5.1	-	5.1	5.4	5.7	-
	Hi PR	221	237	251	-	247	266	281	-	281	303	320	-	321	345	364	-	361	388	410	-	398	429	453	-
	Lo PR	112	119	130	-	118	126	137	-	123	131	143	-	129	137	150	-	135	144	157	-	140	149	162	-
	MBh	27.4	28.4	31.1	-	26.8	27.7	30.4	-	26.1	27.1	29.7	-	25.5	26.4	28.9	-	24.2	25.1	27.5	-	22.4	23.2	25.5	-
	S/T	0.75	0.63	0.43	-	0.78	0.65	0.45	-	0.80	0.67	0.46	-	0.82	0.69	0.48	-	0.85	0.71	0.49	-	0.86	0.72	0.50	-
	ΔT	18	16	12	-	18	16	12	-	18	16	12	-	18	16	12	-	18	16	12	-	17	15	11	-
kW	1.98	2.02	2.08	-	2.12	2.16	2.22	-	2.24	2.29	2.36	-	2.35	2.40	2.47	-	2.44	2.49	2.57	-	2.52	2.57	2.65	-	
Amps	2.3	2.4	2.6	-	2.8	3.0	3.2	-	3.4	3.6	3.9	-	4.0	4.2	4.5	-	4.5	4.7	5.1	-	5.1	5.3	5.6	-	
Hi PR	218	235	248	-	245	264	278	-	279	300	317	-	317	342	361	-	357	384	406	-	394	425	448	-	
Lo PR	111	118	129	-	117	124	136	-	122	129	141	-	128	136	148	-	134	142	155	-	138	147	161	-	
MBh	25.3	26.2	28.7	-	24.7	25.6	28.1	-	24.1	25.0	27.4	-	23.5	24.4	26.7	-	22.3	23.2	25.4	-	20.7	21.5	23.5	-	
S/T	0.72	0.60	0.42	-	0.75	0.63	0.43	-	0.77	0.64	0.44	-	0.79	0.66	0.46	-	0.82	0.69	0.48	-	0.83	0.69	0.48	-	
ΔT	18	16	12	-	19	16	12	-	19	16	12	-	19	16	12	-	18	16	12	-	17	15	11	-	
kW	1.94	1.97	2.03	-	2.07	2.11	2.17	-	2.19	2.23	2.30	-	2.30	2.34	2.41	-	2.38	2.43	2.51	-	2.46	2.51	2.59	-	
Amps	2.1	2.2	2.4	-	2.6	2.8	3.0	-	3.2	3.4	3.7	-	3.7	3.9	4.2	-	4.3	4.5	4.8	-	4.8	5.0	5.3	-	
Hi PR	212	228	241	-	238	256	270	-	270	291	307	-	308	331	350	-	346	373	394	-	383	412	435	-	
Lo PR	107	114	125	-	114	121	132	-	118	126	137	-	124	132	144	-	130	138	151	-	134	143	156	-	

75	MBh	28.7	29.5	32.0	34.3	28.0	28.9	31.2	33.5	27.4	28.2	30.5	32.7	26.7	27.5	29.8	31.9	25.4	26.1	28.3	30.3	23.5	24.2	26.2	28.1
	S/T	0.89	0.80	0.61	0.39	0.93	0.83	0.63	0.40	0.95	0.85	0.64	0.41	0.98	0.88	0.66	0.43	1.00	0.91	0.69	0.44	1.00	0.92	0.69	0.45
	ΔT	20	18	15	10	20	19	15	11	20	19	15	11	20	19	15	11	20	19	15	10	18	17	14	10
	kW	2.01	2.05	2.11	2.17	2.15	2.19	2.26	2.33	2.28	2.32	2.39	2.47	2.39	2.44	2.51	2.59	2.48	2.53	2.61	2.69	2.56	2.61	2.70	2.78
	Amps	2.4	2.5	2.8	3.0	2.9	3.1	3.4	3.7	3.6	3.8	4.0	4.4	4.1	4.3	4.6	5.0	4.7	4.9	5.2	5.6	5.2	5.5	5.8	6.2
	Hi PR	223	240	253	264	250	269	284	296	284	306	323	337	324	348	368	384	364	392	414	432	402	433	457	477
	Lo PR	113	120	131	140	119	127	139	148	124	132	144	153	130	139	151	161	137	145	159	169	141	150	164	175
	MBh	27.9	28.7	31.1	33.3	27.2	28.0	30.3	32.6	26.6	27.4	29.6	31.8	25.9	26.7	28.9	31.0	24.6	25.4	27.4	29.5	22.8	23.5	25.4	27.3
	S/T	0.85	0.76	0.58	0.37	0.88	0.79	0.60	0.38	0.91	0.81	0.61	0.39	0.94	0.84	0.63	0.41	0.97	0.87	0.66	0.42	0.98	0.88	0.66	0.43
	ΔT	21	19	16	11	21	19	16	11	21	19	16	11	21	20	16	11	21	19	16	11	20	18	15	10
kW	1.99	2.03	2.09	2.15	2.14	2.18	2.24	2.31	2.26	2.30	2.37	2.45	2.37	2.42	2.49	2.57	2.46	2.51	2.59	2.67	2.54	2.59	2.67	2.76	
Amps	2.3	2.5	2.7	3.0	2.9	3.0	3.3	3.6	3.5	3.7	4.0	4.3	4.1	4.3	4.6	4.9	4.6	4.8	5.1	5.5	5.1	5.4	5.7	6.1	
Hi PR	221	237	251	261	248	266	281	293	281	303	320	334	321	345	364	380	361	388	410	427	399	429	453	472	
Lo PR	112	119	130	138	118	126	137	146	123	131	143	152	129	137	150	160	135	144	157	167	140	149	162	173	
MBh	25.7	26.5	28.7	30.8	25.1	25.9	28.0	30.0	24.5	25.2	27.3	29.3	23.9	24.6	26.7	28.6	22.7	23.4	25.3	27.2	21.1	21.7	23.5	25.2	
S/T	0.82	0.74	0.56	0.36	0.85	0.76	0.58	0.37	0.87	0.78	0.59	0.38	0.90	0.81	0.61	0.39	0.94	0.84	0.63	0.41	0.94	0.84	0.64	0.41	
ΔT	21	19	16	11	21	20	16	11	21	20	16	11	22	20	16	11	21	20	16	11	20	18	15	10	
kW	1.96	1.99	2.05	2.11	2.09	2.13	2.19	2.26	2.21	2.25	2.32	2.39	2.31	2.36	2.43	2.51	2.40	2.45	2.53	2.61	2.48	2.53	2.61	2.69	
Amps	2.1	2.3	2.5	2.8	2.7	2.8	3.1	3.4	3.3	3.5	3.7	4.0	3.8	4.0	4.3	4.6	4.4	4.6	4.9	5.2	4.9	5.1	5.4	5.8	
Hi PR	214	230	243	254	240	258	273	285	273	294	310	324	311	335	353	369	350	376	398	415	387	416	439	458	
Lo PR	109	115	126	134	115	122	133	142	119	127	138	147	125	133	145	155	131	140	152	162	136	144	158	168	

IDB: Entering Indoor Dry Bulb Temperature  
 Shaded area reflects ACCA (TVA) conditions  
 kW=Total system power  
 Amps = outdoor unit amps (comp.+fan)  
 Design Subcooling 9 ±3 °F @ the liquid service valve, AHRI 95 test conditions



EXPANDED COOLING DATA — MODEL: ASZ140301A\* / CA\*F3642\*6A\*+TXV / MBR1600\*\* -1 (CONT.)

IDB*	Airflow	Outdoor Ambient Temperature																							
		65°F				75°F				85°F				95°F				105°F				115°F			
		59	63	67	71	59	63	67	71	59	63	67	71	59	63	67	71	59	63	67	71	59	63	67	71
80	MBh	29.2	29.8	31.9	34.1	28.5	29.2	31.1	33.3	27.9	28.5	30.4	32.5	27.2	27.8	29.7	31.7	25.8	26.4	28.2	30.1	23.9	24.4	26.1	27.9
	S/T	1.00	0.92	0.75	0.56	1.00	0.95	0.78	0.58	1.00	1.00	0.80	0.59	1.00	1.00	0.82	0.61	1.00	1.00	0.85	0.64	1.00	1.00	0.86	0.64
	ΔT	23	21	19	15	22	22	19	15	22	22	19	15	21	22	19	15	20	21	19	15	19	19	17	14
	kW	2.02	2.06	2.12	2.19	2.17	2.21	2.28	2.35	2.29	2.34	2.41	2.49	2.40	2.45	2.53	2.61	2.50	2.55	2.63	2.71	2.58	2.64	2.72	2.80
	Amps	2.4	2.6	2.8	3.1	3.0	3.2	3.4	3.7	3.7	3.9	4.1	4.5	4.2	4.4	4.7	5.1	4.8	5.0	5.3	5.7	5.3	5.6	5.9	6.3
	Hi PR	225	242	256	267	253	272	287	299	287	309	326	340	327	352	372	388	368	396	418	436	407	438	462	482
	Lo PR	114	121	133	141	121	128	140	149	125	133	146	155	132	140	153	163	138	147	160	171	143	152	166	177
	MBh	28.4	29.0	31.0	33.1	27.7	28.3	30.2	32.3	27.0	27.6	29.5	31.6	26.4	27.0	28.8	30.8	25.1	25.6	27.4	29.2	23.2	23.7	25.3	27.1
	S/T	0.94	0.88	0.71	0.53	0.97	0.91	0.74	0.55	0.99	0.93	0.76	0.57	1.00	0.96	0.78	0.59	1.00	1.00	0.81	0.61	1.00	1.00	0.82	0.61
	ΔT	23	22	19	15	24	23	20	16	24	23	20	16	23	23	20	16	22	22	19	16	20	21	18	15
kW	2.01	2.05	2.11	2.17	2.15	2.19	2.26	2.33	2.28	2.32	2.39	2.47	2.39	2.44	2.51	2.59	2.48	2.53	2.61	2.69	2.56	2.61	2.70	2.78	
Amps	2.4	2.5	2.8	3.0	2.9	3.1	3.4	3.7	3.6	3.8	4.0	4.4	4.1	4.3	4.6	5.0	4.7	4.9	5.2	5.6	5.2	5.5	5.8	6.2	
Hi PR	223	240	253	264	250	269	284	296	284	306	323	337	324	348	368	384	364	392	414	432	403	433	457	477	
Lo PR	113	120	131	140	119	127	139	148	124	132	144	154	130	139	151	161	137	145	159	169	141	150	164	175	
MBh	26.2	26.7	28.6	30.5	25.6	26.1	27.9	29.8	25.0	25.5	27.2	29.1	24.3	24.9	26.6	28.4	23.1	23.6	25.3	27.0	21.4	21.9	23.4	25.0	
S/T	0.90	0.85	0.69	0.51	0.93	0.88	0.71	0.53	0.96	0.90	0.73	0.55	0.99	0.93	0.75	0.56	1.03	0.96	0.78	0.59	1.04	0.97	0.79	0.59	
ΔT	24	23	20	16	24	23	20	16	24	23	20	16	24	23	20	16	24	23	20	16	22	21	18	15	
kW	1.97	2.00	2.06	2.12	2.10	2.14	2.21	2.27	2.22	2.27	2.34	2.41	2.33	2.38	2.45	2.53	2.42	2.47	2.55	2.63	2.50	2.55	2.63	2.72	
Amps	2.2	2.4	2.6	2.8	2.7	2.9	3.2	3.4	3.4	3.5	3.8	4.1	3.9	4.1	4.4	4.7	4.4	4.7	5.0	5.3	5.0	5.2	5.5	5.9	
Hi PR	216	233	246	256	243	261	276	287	276	297	313	327	314	338	357	372	353	380	402	419	390	420	444	463	
Lo PR	110	117	127	136	116	123	135	143	120	128	140	149	126	135	147	156	133	141	154	164	137	146	159	170	

85	MBh	29.7	30.3	31.7	33.9	29.0	29.6	31.0	33.1	28.3	28.9	30.3	32.3	27.6	28.2	29.5	31.5	26.3	26.8	28.0	29.9	24.3	24.8	26.0	27.7
	S/T	1.00	0.99	0.90	0.73	1.00	1.00	0.93	0.75	1.00	1.00	0.95	0.77	1.00	1.00	0.98	0.80	1.00	1.00	1.00	0.83	1.00	1.00	1.00	0.83
	ΔT	23	23	22	19	23	23	22	19	22	22	22	19	22	22	23	20	20	21	22	19	19	19	20	18
	kW	2.04	2.08	2.14	2.20	2.18	2.23	2.29	2.36	2.31	2.36	2.43	2.50	2.42	2.47	2.55	2.63	2.52	2.57	2.65	2.74	2.60	2.66	2.74	2.83
	Amps	2.5	2.7	2.9	3.2	3.1	3.3	3.5	3.8	3.7	3.9	4.2	4.5	4.3	4.5	4.8	5.2	4.9	5.1	5.4	5.8	5.4	5.7	6.0	6.4
	Hi PR	227	245	258	269	255	274	290	302	290	312	330	344	330	356	375	392	372	400	422	440	411	442	467	487
	Lo PR	115	123	134	143	122	130	141	151	127	135	147	157	133	141	154	164	139	148	162	172	144	153	167	178
	MBh	28.9	29.4	30.8	32.9	28.2	28.7	30.1	32.1	27.5	28.0	29.4	31.3	26.8	27.4	28.7	30.6	25.5	26.0	27.2	29.0	23.6	24.1	25.2	26.9
	S/T	0.98	0.95	0.85	0.69	1.00	0.98	0.88	0.72	1.00	1.00	0.91	0.74	1.00	1.00	0.94	0.76	1.00	1.00	0.97	0.79	1.00	1.00	0.98	0.80
	ΔT	25	24	23	20	25	25	23	20	24	25	23	20	24	24	23	20	22	23	23	20	21	21	22	19
kW	2.02	2.06	2.12	2.19	2.17	2.21	2.28	2.35	2.29	2.34	2.41	2.49	2.40	2.45	2.53	2.61	2.50	2.55	2.63	2.71	2.58	2.64	2.72	2.80	
Amps	2.4	2.6	2.8	3.1	3.0	3.2	3.4	3.7	3.7	3.9	4.1	4.5	4.2	4.4	4.7	5.1	4.8	5.0	5.3	5.7	5.3	5.6	5.9	6.3	
Hi PR	225	242	256	267	253	272	287	299	287	309	326	340	327	352	372	388	368	396	418	436	407	438	462	482	
Lo PR	114	121	133	141	121	128	140	149	125	133	146	155	132	140	153	163	138	147	160	171	143	152	166	177	
MBh	26.6	27.1	28.4	30.3	26.0	26.5	27.8	29.6	25.4	25.9	27.1	28.9	24.8	25.3	26.4	28.2	23.5	24.0	25.1	26.8	21.8	22.2	23.3	24.8	
S/T	0.95	0.91	0.82	0.67	0.98	0.95	0.85	0.69	1.00	0.97	0.87	0.71	1.00	1.00	0.90	0.73	1.00	1.00	0.94	0.76	1.00	1.00	0.94	0.77	
ΔT	25	25	23	20	25	25	24	21	25	25	24	21	25	25	24	21	24	24	24	20	22	22	22	19	
kW	1.98	2.02	2.08	2.14	2.12	2.16	2.22	2.29	2.24	2.29	2.35	2.43	2.35	2.40	2.47	2.55	2.44	2.49	2.57	2.65	2.52	2.57	2.65	2.74	
Amps	2.3	2.4	2.6	2.9	2.8	3.0	3.2	3.5	3.4	3.6	3.9	4.2	4.0	4.2	4.5	4.8	4.5	4.7	5.0	5.4	5.1	5.3	5.6	6.0	
Hi PR	218	235	248	259	245	264	278	290	279	300	317	330	317	341	361	376	357	384	406	423	394	424	448	467	
Lo PR	111	118	129	137	117	124	136	145	122	129	141	150	128	136	148	158	134	142	155	166	138	147	161	171	

IDB: Entering Indoor Dry Bulb Temperature  
 Shaded area reflects AHRl conditions  
 kW=Total system power  
 Design Subcooling 9 ±3 °F @ the liquid service valve, AHRl 95 test conditions  
 Amps = outdoor unit amps (comp.+fan)

EXPANDED COOLING DATA — MODEL: ASZ140361A\* / CA\*F4860\*6A\*+TXV / MBR1600\*\* -1

IDB*	Airflow	Outdoor Ambient Temperature																							
		65°F				75°F				85°F				95°F				105°F				115°F			
		59	63	67	71	59	63	67	71	59	63	67	71	59	63	67	71	59	63	67	71	59	63	67	71
70	MBh	33.9	35.1	38.5	-	33.1	34.3	37.6	-	32.3	33.5	36.7	-	31.5	32.7	35.8	-	30.0	31.1	34.0	-	27.8	28.8	31.5	-
	S/T	0.72	0.60	0.42	-	0.75	0.63	0.43	-	0.77	0.64	0.44	-	0.79	0.66	0.46	-	0.82	0.69	0.48	-	0.83	0.69	0.48	-
	ΔT	19	17	13	-	19	17	13	-	19	17	13	-	19	17	13	-	19	17	13	-	18	16	12	-
	kW	2.34	2.39	2.46	-	2.51	2.56	2.64	-	2.66	2.72	2.80	-	2.79	2.85	2.94	-	2.90	2.96	3.06	-	3.00	3.06	3.16	-
	Amps	8.6	8.8	9.1	-	9.3	9.5	9.8	-	10.1	10.3	10.6	-	10.7	11.0	11.3	-	11.4	11.7	12.0	-	12.0	12.3	12.7	-
	Hi PR	218	235	248	-	245	264	278	-	279	300	317	-	317	342	361	-	357	384	406	-	395	425	448	-
	Lo PR	105	112	122	-	111	118	129	-	115	123	134	-	121	129	141	-	127	135	148	-	132	140	153	-
	MBh	32.9	34.1	37.4	-	32.2	33.3	36.5	-	31.4	32.5	35.6	-	30.6	31.7	34.8	-	29.1	30.2	33.0	-	26.9	27.9	30.6	-
	S/T	0.69	0.58	0.40	-	0.71	0.60	0.41	-	0.73	0.61	0.42	-	0.76	0.63	0.44	-	0.79	0.66	0.45	-	0.79	0.66	0.46	-
	ΔT	20	17	13	-	20	17	13	-	20	17	13	-	20	18	13	-	20	17	13	-	19	16	12	-
kW	2.33	2.37	2.44	-	2.49	2.54	2.62	-	2.64	2.69	2.78	-	2.77	2.83	2.92	-	2.88	2.94	3.03	-	2.98	3.04	3.14	-	
Amps	8.6	8.8	9.0	-	9.2	9.4	9.7	-	10.0	10.2	10.5	-	10.6	10.9	11.2	-	11.3	11.6	11.9	-	11.9	12.2	12.6	-	
Hi PR	216	233	246	-	243	261	276	-	276	297	314	-	314	338	357	-	354	380	402	-	391	420	444	-	
Lo PR	104	111	121	-	110	117	128	-	114	122	133	-	120	128	140	-	126	134	146	-	130	139	151	-	
MBh	30.4	31.5	34.5	-	29.7	30.8	33.7	-	29.0	30.0	32.9	-	28.3	29.3	32.1	-	26.9	27.8	30.5	-	24.9	25.8	28.2	-	
S/T	0.67	0.56	0.38	-	0.69	0.58	0.40	-	0.71	0.59	0.41	-	0.73	0.61	0.42	-	0.76	0.63	0.44	-	0.76	0.64	0.44	-	
ΔT	20	18	13	-	20	18	13	-	20	18	13	-	21	18	14	-	21	18	13	-	19	16	12	-	
kW	2.28	2.32	2.39	-	2.44	2.49	2.56	-	2.58	2.63	2.71	-	2.71	2.76	2.85	-	2.81	2.87	2.96	-	2.90	2.97	3.06	-	
Amps	8.4	8.5	8.8	-	9.0	9.2	9.5	-	9.7	9.9	10.3	-	10.4	10.6	10.9	-	11.0	11.2	11.6	-	11.6	11.9	12.3	-	
Hi PR	210	226	238	-	235	253	267	-	268	288	304	-	305	328	346	-	343	369	390	-	379	408	431	-	
Lo PR	101	107	117	-	107	114	124	-	111	118	129	-	117	124	135	-	122	130	142	-	126	134	147	-	

75	MBh	34.5	35.5	38.4	41.2	33.7	34.7	37.5	40.3	32.9	33.8	36.6	39.3	32.1	33.0	35.7	38.4	30.5	31.4	34.0	36.4	28.2	29.1	31.5	33.8
	S/T	0.82	0.74	0.56	0.36	0.85	0.76	0.58	0.37	0.87	0.78	0.59	0.38	0.90	0.81	0.61	0.39	0.94	0.84	0.63	0.41	0.94	0.84	0.64	0.41
	ΔT	22	20	17	11	22	21	17	12	22	21	17	12	23	21	17	12	23	21	17	12	21	19	16	11
	kW	2.36	2.41	2.48	2.55	2.53	2.58	2.66	2.74	2.68	2.74	2.82	2.91	2.81	2.87	2.96	3.06	2.93	2.99	3.08	3.18	3.02	3.09	3.19	3.29
	Amps	8.7	8.9	9.2	9.5	9.4	9.6	9.9	10.3	10.2	10.4	10.7	11.1	10.8	11.1	11.4	11.8	11.5	11.8	12.1	12.6	12.1	12.4	12.8	13.3
	Hi PR	221	237	251	261	248	266	281	293	282	303	320	334	321	345	364	380	361	388	410	428	399	429	453	472
	Lo PR	106	113	123	131	112	119	130	139	117	124	136	144	123	130	142	152	128	137	149	159	133	141	154	164
	MBh	33.5	34.5	37.3	40.0	32.7	33.7	36.4	39.1	31.9	32.9	35.6	38.2	31.1	32.1	34.7	37.2	29.6	30.5	33.0	35.4	27.4	28.2	30.5	32.8
	S/T	0.78	0.70	0.53	0.34	0.81	0.73	0.55	0.35	0.83	0.75	0.56	0.36	0.86	0.77	0.58	0.37	0.89	0.80	0.60	0.39	0.90	0.81	0.61	0.39
	ΔT	23	21	17	12	23	21	18	12	23	21	18	12	23	22	18	12	23	21	17	12	22	20	16	11
kW	2.34	2.39	2.46	2.54	2.51	2.56	2.64	2.72	2.66	2.72	2.80	2.89	2.79	2.85	2.94	3.03	2.90	2.97	3.06	3.16	3.00	3.06	3.16	3.26	
Amps	8.7	8.8	9.1	9.4	9.3	9.5	9.8	10.2	10.1	10.3	10.6	11.0	10.7	11.0	11.3	11.7	11.4	11.7	12.0	12.5	12.0	12.3	12.7	13.2	
Hi PR	218	235	248	259	245	264	279	290	279	300	317	330	317	342	361	376	357	384	406	423	395	425	448	468	
Lo PR	105	112	122	130	111	118	129	137	116	123	134	143	121	129	141	150	127	135	148	157	132	140	153	163	
MBh	30.9	31.8	34.4	37.0	30.2	31.1	33.6	36.1	29.5	30.3	32.8	35.2	28.7	29.6	32.0	34.4	27.3	28.1	30.4	32.7	25.3	26.0	28.2	30.3	
S/T	0.76	0.68	0.51	0.33	0.78	0.70	0.53	0.34	0.80	0.72	0.54	0.35	0.83	0.74	0.56	0.36	0.86	0.77	0.58	0.37	0.87	0.78	0.59	0.38	
ΔT	23	22	18	12	24	22	18	12	24	22	18	12	24	22	18	12	24	22	18	12	22	20	17	11	
kW	2.29	2.34	2.41	2.48	2.46	2.51	2.58	2.66	2.60	2.65	2.73	2.82	2.73	2.78	2.87	2.96	2.84	2.89	2.98	3.08	2.93	2.99	3.08	3.18	
Amps	8.4	8.6	8.9	9.2	9.1	9.3	9.6	9.9	9.8	10.0	10.4	10.7	10.5	10.7	11.0	11.4	11.1	11.3	11.7	12.1	11.7	12.0	12.4	12.8	
Hi PR	212	228	241	251	238	256	270	282	270	291	307	320	308	331	350	365	346	373	394	411	383	412	435	454	
Lo PR	102	109	119	126	108	115	125	133	112	119	130	139	118	125	137	146	123	131	143	153	128	136	148	158	

IDB: Entering Indoor Dry Bulb Temperature  
 Shaded area reflects ACCA (TVA) conditions  
 kW=Total system power  
 Amps = outdoor unit amps (comp.+fan)  
 Design Subcooling 9 ±3 °F @ the liquid service valve, AHRI 95 test conditions

EXPANDED COOLING DATA — MODEL: ASZ140361A\* / CA\*F4860\*6A\*+TXV / MBR1600\*\*-(CONT.)

IDB*	Airflow	Outdoor Ambient Temperature																							
		65°F				75°F				85°F				95°F				105°F				115°F			
		59	63	67	71	59	63	67	71	59	63	67	71	59	63	67	71	59	63	67	71	59	63	67	71
80	MBh	35.09	35.86	38.31	40.95	34.28	35.03	37.42	40.00	33.46	34.19	36.53	39.05	32.64	33.36	35.64	38.10	31.01	31.69	33.86	36.19	28.73	29.35	31.36	33.53
	S/T	0.90	0.85	0.69	0.51	0.93	0.88	0.71	0.53	0.96	0.90	0.73	0.55	1.00	0.93	0.75	0.56	1.00	0.96	0.78	0.59	1.00	0.97	0.79	0.59
	ΔT	25	24	21	16	25	24	21	17	25	24	21	17	25	24	21	17	25	24	21	16	22	22	19	15
	kW	2.38	2.43	2.50	2.57	2.55	2.60	2.68	2.77	2.70	2.76	2.84	2.93	2.84	2.90	2.99	3.08	2.95	3.01	3.11	3.21	3.05	3.11	3.21	3.32
	Amps	8.8	9.0	9.3	9.6	9.5	9.7	10.0	10.3	10.3	10.5	10.8	11.2	10.9	11.2	11.5	12.0	11.6	11.9	12.3	12.7	12.3	12.5	13.0	13.4
	Hi PR	223	240	253	264	250	269	284	296	284	306	323	337	324	349	368	384	364	392	414	432	403	433	457	477
	Lo PR	107	114	125	133	113	121	132	140	118	125	137	146	124	132	144	153	130	138	151	160	134	143	156	166
	MBh	34.1	34.8	37.2	39.8	33.3	34.0	36.3	38.8	32.5	33.2	35.5	37.9	31.7	32.4	34.6	37.0	30.1	30.8	32.9	35.1	27.9	28.5	30.4	32.5
	S/T	0.86	0.81	0.66	0.49	0.89	0.84	0.68	0.51	0.91	0.86	0.70	0.52	0.94	0.88	0.72	0.54	0.98	0.92	0.75	0.56	0.99	0.93	0.75	0.56
	ΔT	26	25	21	17	26	25	22	17	26	25	22	17	26	25	22	17	26	25	22	17	24	23	20	16
	kW	2.36	2.41	2.48	2.56	2.53	2.58	2.66	2.74	2.68	2.74	2.82	2.91	2.81	2.87	2.96	3.06	2.93	2.99	3.08	3.18	3.02	3.09	3.19	3.29
	Amps	8.7	8.9	9.2	9.5	9.4	9.6	9.9	10.3	10.2	10.4	10.7	11.1	10.8	11.1	11.4	11.8	11.5	11.8	12.1	12.6	12.2	12.4	12.8	13.3
Hi PR	221	237	251	261	248	266	281	293	282	303	320	334	321	345	364	380	361	388	410	428	399	429	453	472	
Lo PR	106	113	123	131	112	119	130	139	117	124	136	144	123	130	142	152	128	137	149	159	133	141	154	164	
MBh	31.4	32.1	34.3	36.7	30.7	31.4	33.5	35.8	30.0	30.6	32.7	35.0	29.3	29.9	31.9	34.1	27.8	28.4	30.3	32.4	25.7	26.3	28.1	30.0	
S/T	0.83	0.78	0.63	0.47	0.86	0.81	0.66	0.49	0.88	0.83	0.67	0.50	0.91	0.85	0.69	0.52	0.94	0.89	0.72	0.54	0.95	0.89	0.73	0.54	
ΔT	26	25	22	17	26	25	22	18	26	25	22	18	27	26	22	18	27	26	22	17	25	23	20	16	
kW	2.31	2.36	2.42	2.50	2.47	2.52	2.60	2.68	2.62	2.67	2.76	2.84	2.75	2.81	2.89	2.98	2.86	2.92	3.01	3.10	2.95	3.01	3.11	3.21	
Amps	8.5	8.7	9.0	9.3	9.1	9.4	9.6	10.0	9.9	10.1	10.4	10.8	10.5	10.8	11.1	11.5	11.2	11.5	11.8	12.2	11.8	12.1	12.5	13.0	
Hi PR	214	230	243	254	240	258	273	285	273	294	310	324	311	335	353	369	350	377	398	415	387	416	439	458	
Lo PR	103	110	120	127	109	116	126	135	113	120	131	140	119	126	138	147	125	133	145	154	129	137	150	159	
85	MBh	35.71	36.40	38.12	40.67	34.88	35.55	37.23	39.72	34.04	34.70	36.35	38.78	33.21	33.86	35.46	37.83	31.55	32.16	33.69	35.94	29.23	29.79	31.20	33.29
	S/T	0.95	0.91	0.82	0.67	0.98	0.95	0.85	0.69	1.00	0.97	0.87	0.71	1.00	1.00	0.90	0.73	1.00	1.00	0.94	0.76	1.00	1.00	0.94	0.77
	ΔT	26	26	24	21	27	26	25	21	26	26	25	21	26	26	25	22	25	25	25	21	23	23	23	20
	kW	2.40	2.45	2.52	2.59	2.57	2.62	2.70	2.79	2.72	2.78	2.87	2.96	2.86	2.92	3.01	3.11	2.97	3.04	3.13	3.23	3.07	3.14	3.24	3.34
	Amps	8.9	9.1	9.4	9.7	9.6	9.8	10.1	10.4	10.3	10.6	10.9	11.3	11.0	11.3	11.6	12.1	11.7	12.0	12.4	12.8	12.4	12.7	13.1	13.6
	Hi PR	225	242	256	267	253	272	287	299	287	309	326	340	327	352	372	388	368	396	418	436	407	438	462	482
	Lo PR	108	115	126	134	115	122	133	142	119	127	138	147	125	133	145	155	131	139	152	162	136	144	157	168
	MBh	34.7	35.3	37.0	39.5	33.9	34.5	36.1	38.6	33.1	33.7	35.3	37.6	32.2	32.9	34.4	36.7	30.6	31.2	32.7	34.9	28.4	28.9	30.3	32.3
	S/T	0.90	0.87	0.79	0.64	0.93	0.90	0.81	0.66	0.96	0.92	0.83	0.68	0.99	0.95	0.86	0.70	1.00	0.99	0.89	0.73	1.00	1.00	0.90	0.73
	ΔT	27	27	25	22	28	27	26	22	28	27	26	22	28	27	26	22	27	27	26	22	25	25	24	21
	kW	2.38	2.43	2.50	2.57	2.55	2.60	2.68	2.77	2.70	2.76	2.84	2.93	2.84	2.90	2.99	3.08	2.95	3.01	3.11	3.21	3.05	3.11	3.21	3.32
	Amps	8.8	9.0	9.3	9.6	9.5	9.7	10.0	10.3	10.3	10.5	10.8	11.2	10.9	11.2	11.5	12.0	11.6	11.9	12.3	12.7	12.3	12.5	13.0	13.4
Hi PR	223	240	253	264	250	269	284	296	284	306	323	337	324	349	368	384	364	392	414	432	403	433	457	477	
Lo PR	107	114	125	133	113	121	132	140	118	125	137	146	124	132	144	153	130	138	151	160	134	143	156	166	
MBh	32.0	32.6	34.2	36.4	31.3	31.9	33.4	35.6	30.5	31.1	32.6	34.7	29.8	30.3	31.8	33.9	28.3	28.8	30.2	32.2	26.2	26.7	28.0	29.8	
S/T	0.87	0.84	0.76	0.61	0.90	0.87	0.78	0.64	0.92	0.89	0.80	0.65	0.95	0.92	0.83	0.67	0.99	0.95	0.86	0.70	1.00	0.96	0.87	0.71	
ΔT	28	27	26	22	28	28	26	23	28	28	26	23	28	28	26	23	28	28	26	23	26	26	24	21	
kW	2.33	2.37	2.44	2.52	2.49	2.54	2.62	2.70	2.64	2.69	2.78	2.86	2.77	2.83	2.92	3.01	2.88	2.94	3.03	3.13	2.98	3.04	3.13	3.24	
Amps	8.6	8.8	9.0	9.4	9.2	9.4	9.7	10.1	10.0	10.2	10.5	10.9	10.6	10.9	11.2	11.6	11.3	11.6	11.9	12.4	11.9	12.2	12.6	13.1	
Hi PR	216	233	246	256	243	261	276	287	276	297	313	327	314	338	357	372	353	380	402	419	391	420	444	463	
Lo PR	104	111	121	129	110	117	128	136	114	122	133	141	120	128	139	149	126	134	146	156	130	138	151	161	

IDB: Entering Indoor Dry Bulb Temperature  
 Shaded area reflects AHRI conditions  
 kW=Total system power  
 Design Subcooling 9 ±3 °F @ the liquid service valve, AHRI 95 test conditions  
 Amps = outdoor unit amps (comp. +fan)

EXPANDED COOLING DATA — MODEL: ASZ140421A\* / CA\*F4860\*6A\*+TXV / MBR2000\*\* -1

IDB*	Airflow	Outdoor Ambient Temperature																							
		65°F				75°F				85°F				95°F				105°F				115°F			
		59	63	67	71	59	63	67	71	59	63	67	71	59	63	67	71	59	63	67	71	59	63	67	71
70	MBh	39.2	40.6	44.5	-	38.3	39.7	43.5	-	37.4	38.7	42.4	-	36.5	37.8	41.4	-	34.6	35.9	39.3	-	32.1	33.3	36.4	-
	S/T	0.77	0.65	0.45	-	0.80	0.67	0.46	-	0.82	0.69	0.48	-	0.85	0.71	0.49	-	0.88	0.74	0.51	-	0.89	0.74	0.51	-
	ΔT	18	15	12	-	18	16	12	-	18	16	12	-	18	16	12	-	18	15	12	-	17	14	11	-
	kW	2.65	2.71	2.78	-	2.84	2.90	2.98	-	3.01	3.07	3.16	-	3.15	3.22	3.31	-	3.28	3.34	3.45	-	3.38	3.45	3.56	-
	Amps	9.7	9.9	10.2	-	10.4	10.7	11.0	-	11.3	11.6	12.0	-	12.1	12.4	12.8	-	12.8	13.1	13.6	-	13.6	13.9	14.4	-
	Hi PR	218	234	247	-	244	263	277	-	278	299	315	-	316	340	359	-	356	383	404	-	393	423	447	-
	Lo PR	107	114	125	-	113	121	132	-	118	125	137	-	124	132	144	-	130	138	151	-	134	143	156	-
	MBh	38.1	39.4	43.2	-	37.2	38.5	42.2	-	36.3	37.6	41.2	-	35.4	36.7	40.2	-	33.6	34.9	38.2	-	31.2	32.3	35.4	-
	S/T	0.74	0.62	0.43	-	0.77	0.64	0.44	-	0.79	0.66	0.45	-	0.81	0.68	0.47	-	0.84	0.70	0.49	-	0.85	0.71	0.49	-
	ΔT	18	16	12	-	19	16	12	-	19	16	12	-	19	16	12	-	19	16	12	-	17	15	11	-
kW	2.63	2.69	2.76	-	2.82	2.88	2.96	-	2.98	3.04	3.14	-	3.13	3.19	3.29	-	3.25	3.32	3.42	-	3.36	3.43	3.53	-	
Amps	9.6	9.8	10.1	-	10.4	10.6	10.9	-	11.2	11.5	11.8	-	12.0	12.2	12.6	-	12.7	13.0	13.4	-	13.4	13.8	14.2	-	
Hi PR	215	232	245	-	242	260	275	-	275	296	312	-	313	337	356	-	352	379	400	-	389	419	442	-	
Lo PR	106	113	123	-	112	120	130	-	117	124	136	-	123	130	142	-	129	137	149	-	133	141	154	-	
MBh	35.1	36.4	39.9	-	34.3	35.6	39.0	-	33.5	34.7	38.0	-	32.7	33.9	37.1	-	31.0	32.2	35.2	-	28.8	29.8	32.7	-	
S/T	0.71	0.59	0.41	-	0.74	0.62	0.43	-	0.76	0.63	0.44	-	0.78	0.65	0.45	-	0.81	0.68	0.47	-	0.82	0.68	0.47	-	
ΔT	19	16	12	-	19	16	12	-	19	16	13	-	19	17	13	-	19	16	12	-	18	15	12	-	
kW	2.58	2.63	2.70	-	2.76	2.81	2.89	-	2.92	2.97	3.06	-	3.06	3.12	3.21	-	3.17	3.24	3.34	-	3.28	3.35	3.45	-	
Amps	9.4	9.6	9.9	-	10.1	10.3	10.6	-	10.9	11.2	11.5	-	11.6	11.9	12.3	-	12.4	12.7	13.1	-	13.1	13.4	13.8	-	
Hi PR	209	225	237	-	234	252	266	-	267	287	303	-	304	327	345	-	342	368	388	-	377	406	429	-	
Lo PR	103	110	120	-	109	116	127	-	113	120	132	-	119	127	138	-	125	133	145	-	129	137	150	-	
75	MBh	39.9	41.0	44.4	47.7	38.9	40.1	43.4	46.6	38.0	39.1	42.4	45.5	37.1	38.2	41.3	44.4	35.2	36.3	39.3	42.1	32.6	33.6	36.4	39.0
	S/T	0.88	0.79	0.60	0.38	0.91	0.82	0.62	0.40	0.94	0.84	0.63	0.41	0.97	0.86	0.65	0.42	1.00	0.90	0.68	0.44	1.00	0.90	0.68	0.44
	ΔT	20	19	15	11	21	19	16	11	21	19	16	11	21	19	16	11	21	19	16	11	19	18	15	10
	kW	2.67	2.73	2.80	2.89	2.86	2.92	3.01	3.10	3.03	3.09	3.18	3.28	3.18	3.24	3.34	3.45	3.30	3.37	3.47	3.58	3.41	3.48	3.59	3.70
	Amps	9.8	10.0	10.3	10.7	10.5	10.8	11.1	11.5	11.4	11.7	12.1	12.5	12.2	12.5	12.9	13.3	12.9	13.3	13.7	14.2	13.7	14.0	14.5	15.0
	Hi PR	220	236	250	260	247	265	280	292	280	302	319	332	319	344	363	379	359	387	408	426	397	427	451	471
	Lo PR	108	115	126	134	115	122	133	142	119	127	138	147	125	133	145	155	131	140	152	162	136	144	158	168
	MBh	38.7	39.8	43.1	46.3	37.8	38.9	42.1	45.2	36.9	38.0	41.1	44.1	36.0	37.1	40.1	43.1	34.2	35.2	38.1	40.9	31.7	32.6	35.3	37.9
	S/T	0.84	0.75	0.57	0.37	0.87	0.78	0.59	0.38	0.89	0.80	0.60	0.39	0.92	0.82	0.62	0.40	0.96	0.86	0.65	0.42	0.96	0.86	0.65	0.42
	ΔT	21	20	16	11	22	20	16	11	22	20	16	11	22	20	16	11	22	20	16	11	20	18	15	10
kW	2.65	2.71	2.78	2.87	2.84	2.90	2.98	3.07	3.01	3.07	3.16	3.26	3.15	3.22	3.32	3.42	3.28	3.34	3.45	3.56	3.38	3.45	3.56	3.68	
Amps	9.7	9.9	10.2	10.6	10.4	10.7	11.0	11.4	11.3	11.6	12.0	12.4	12.1	12.4	12.8	13.2	12.8	13.1	13.6	14.1	13.6	13.9	14.4	14.9	
Hi PR	218	234	247	258	244	263	277	289	278	299	316	329	316	340	359	375	356	383	404	422	393	423	447	466	
Lo PR	107	114	125	133	113	121	132	140	118	125	137	146	124	132	144	153	130	138	151	161	134	143	156	166	
MBh	35.7	36.8	39.8	42.7	34.9	35.9	38.9	41.7	34.1	35.1	38.0	40.7	33.2	34.2	37.0	39.7	31.6	32.5	35.2	37.8	29.2	30.1	32.6	35.0	
S/T	0.81	0.72	0.55	0.35	0.84	0.75	0.57	0.37	0.86	0.77	0.58	0.37	0.89	0.79	0.60	0.39	0.92	0.82	0.62	0.40	0.93	0.83	0.63	0.40	
ΔT	22	20	16	11	22	20	17	11	22	20	17	11	22	20	17	12	22	20	16	11	20	19	15	11	
kW	2.60	2.65	2.72	2.80	2.78	2.83	2.92	3.00	2.94	3.00	3.09	3.18	3.08	3.14	3.24	3.34	3.20	3.27	3.37	3.47	3.30	3.37	3.48	3.59	
Amps	9.4	9.7	10.0	10.3	10.2	10.4	10.7	11.1	11.0	11.3	11.6	12.1	11.7	12.0	12.4	12.9	12.5	12.8	13.2	13.7	13.2	13.5	14.0	14.5	
Hi PR	211	227	240	250	237	255	269	281	269	290	306	319	307	330	349	364	345	371	392	409	381	410	433	452	
Lo PR	104	111	121	129	110	117	128	136	114	122	133	142	120	128	140	149	126	134	146	156	130	139	151	161	

IDB: Entering Indoor Dry Bulb Temperature  
 Shaded area reflects ACCA (TVA) conditions  
 kW=Total system power  
 Amps = outdoor unit amps (comp.+fan)  
 Design Subcooling 9 ±3 °F @ the liquid service valve, AHRI 95 test conditions

EXPANDED COOLING DATA — MODEL: ASZ140421A\* / CA\*F4860\*6A\*+TXV / MBR2000\*\* -1 (CONT.)

IDB*	Airflow	Outdoor Ambient Temperature																							
		65°F				75°F				85°F				95°F				105°F				115°F			
		59	63	67	71	59	63	67	71	59	63	67	71	59	63	67	71	59	63	67	71	59	63	67	71
1575	MBh	40.6	41.5	44.3	47.3	39.6	40.5	43.3	46.2	38.7	39.5	42.2	45.1	37.7	38.6	41.2	44.0	35.9	36.6	39.1	41.8	33.2	33.9	36.3	38.8
	S/T	0.97	0.91	0.74	0.55	1.00	0.94	0.76	0.57	1.00	0.96	0.78	0.59	1.00	1.00	0.81	0.60	1.00	1.00	0.84	0.63	1.00	1.00	0.85	0.63
	ΔT	23	22	19	15	23	22	19	15	22	23	19	16	22	23	19	16	21	21	19	15	19	20	18	14
	kW	2.69	2.75	2.83	2.91	2.88	2.94	3.03	3.12	3.05	3.11	3.21	3.31	3.20	3.27	3.37	3.47	3.33	3.40	3.50	3.61	3.44	3.51	3.62	3.73
	Amps	9.9	10.1	10.4	10.8	10.6	10.9	11.2	11.6	11.5	11.8	12.2	12.6	12.3	12.6	13.0	13.5	13.1	13.4	13.8	14.3	13.8	14.2	14.6	15.2
	Hi PR	222	239	252	263	249	268	283	295	283	305	322	336	323	347	367	382	363	391	412	430	401	432	456	475
	Lo PR	110	117	127	136	116	123	134	143	120	128	140	149	126	134	147	156	132	141	154	164	137	146	159	169
	MBh	39.4	40.2	43.0	46.0	38.5	39.3	42.0	44.9	37.6	38.4	41.0	43.8	36.6	37.4	40.0	42.8	34.8	35.6	38.0	40.6	32.2	32.9	35.2	37.6
	S/T	0.92	0.86	0.70	0.53	0.95	0.90	0.73	0.54	0.98	0.92	0.75	0.56	1.00	0.95	0.77	0.58	1.00	0.98	0.80	0.60	1.00	0.99	0.81	0.60
	80	ΔT	24	23	20	16	24	23	20	16	24	23	20	16	24	23	20	16	23	23	20	16	21	21	19
kW		2.67	2.73	2.80	2.89	2.86	2.92	3.01	3.10	3.03	3.09	3.18	3.28	3.18	3.24	3.34	3.45	3.30	3.37	3.48	3.59	3.41	3.48	3.59	3.71
Amps		9.8	10.0	10.3	10.7	10.5	10.8	11.1	11.5	11.4	11.7	12.1	12.5	12.2	12.5	12.9	13.3	12.9	13.3	13.7	14.2	13.7	14.0	14.5	15.0
Hi PR		220	237	250	260	247	265	280	292	280	302	319	332	319	344	363	379	359	387	408	426	397	427	451	471
Lo PR		109	115	126	134	115	122	133	142	119	127	138	147	125	133	145	155	131	140	152	162	136	144	158	168
MBh		36.4	37.1	39.7	42.4	35.5	36.3	38.8	41.4	34.7	35.4	37.8	40.5	33.8	34.6	36.9	39.5	32.1	32.8	35.1	37.5	29.8	30.4	32.5	34.7
S/T		0.89	0.83	0.68	0.51	0.92	0.86	0.70	0.53	0.94	0.89	0.72	0.54	0.97	0.91	0.74	0.56	1.01	0.95	0.77	0.58	1.02	0.96	0.78	0.58
ΔT		24	23	20	16	25	24	20	16	25	24	20	16	25	24	21	16	24	23	20	16	23	22	19	15
kW		2.61	2.67	2.74	2.82	2.80	2.85	2.94	3.03	2.96	3.02	3.11	3.21	3.10	3.17	3.26	3.36	3.22	3.29	3.39	3.50	3.33	3.40	3.50	3.62
Amps		9.5	9.7	10.0	10.4	10.3	10.5	10.8	11.2	11.1	11.4	11.7	12.2	11.9	12.1	12.5	13.0	12.6	12.9	13.3	13.8	13.3	13.6	14.1	14.6
1225	Hi PR	213	229	242	253	239	257	272	284	272	293	309	322	310	333	352	367	349	375	396	413	385	414	438	456
	Lo PR	105	112	122	130	111	118	129	138	116	123	134	143	121	129	141	150	127	135	148	157	132	140	153	163

1575	MBh	41.3	42.1	44.1	47.0	40.3	41.1	43.0	45.9	39.4	40.1	42.0	44.8	38.4	39.1	41.0	43.7	36.5	37.2	38.9	41.5	33.8	34.4	36.1	38.5
	S/T	1.00	0.98	0.88	0.72	1.00	1.00	0.91	0.74	1.00	1.00	0.94	0.76	1.00	1.00	0.97	0.78	1.00	1.00	1.00	0.81	1.00	1.00	1.00	0.82
	ΔT	24	24	23	20	24	24	23	20	23	23	23	20	22	23	23	20	22	23	23	20	20	20	21	18
	kW	2.71	2.77	2.85	2.93	2.91	2.96	3.05	3.15	3.08	3.14	3.23	3.33	3.23	3.29	3.39	3.50	3.35	3.42	3.53	3.64	3.46	3.54	3.65	3.76
	Amps	9.9	10.2	10.5	10.9	10.7	11.0	11.3	11.7	11.6	11.9	12.3	12.7	12.4	12.7	13.1	13.6	13.2	13.5	13.9	14.5	13.9	14.3	14.8	15.3
	Hi PR	224	241	255	266	252	271	286	298	286	308	325	339	326	351	370	386	367	395	417	434	405	436	460	480
	Lo PR	111	118	129	137	117	124	136	145	122	129	141	150	128	136	148	158	134	142	155	165	138	147	161	171
	MBh	40.1	40.9	42.8	45.6	39.1	39.9	41.8	44.6	38.2	39.0	40.8	43.5	37.3	38.0	39.8	42.5	35.4	36.1	37.8	40.3	32.8	33.4	35.0	37.4
	S/T	0.97	0.93	0.84	0.68	1.00	0.97	0.87	0.71	1.00	0.99	0.89	0.72	1.00	1.00	0.92	0.75	1.00	1.00	0.96	0.78	1.00	1.00	0.97	0.78
	ΔT	25	25	24	20	26	25	24	21	25	25	24	21	24	25	24	21	23	24	24	21	22	22	22	19
85	kW	2.69	2.75	2.83	2.91	2.88	2.94	3.03	3.12	3.05	3.11	3.21	3.31	3.20	3.27	3.37	3.47	3.33	3.40	3.50	3.61	3.44	3.51	3.62	3.73
	Amps	9.9	10.1	10.4	10.8	10.6	10.9	11.2	11.6	11.5	11.8	12.2	12.6	12.3	12.6	13.0	13.5	13.1	13.4	13.8	14.3	13.8	14.2	14.6	15.2
	Hi PR	222	239	252	263	249	268	283	295	283	305	322	336	323	347	367	382	363	391	412	430	401	432	456	475
	Lo PR	110	117	127	136	116	123	134	143	120	128	140	149	126	134	147	156	132	141	154	164	137	146	159	169
	MBh	37.0	37.7	39.5	42.1	36.1	36.8	38.6	41.2	35.3	36.0	37.7	40.2	34.4	35.1	36.7	39.2	32.7	33.3	34.9	37.2	30.3	30.9	32.3	34.5
	S/T	0.93	0.90	0.81	0.66	0.96	0.93	0.84	0.68	0.99	0.95	0.86	0.70	1.00	0.99	0.89	0.72	1.00	1.00	0.92	0.75	1.00	1.00	0.93	0.76
	ΔT	26	25	24	21	26	26	24	21	26	26	24	21	26	26	25	21	25	25	24	21	23	23	23	20
	kW	2.63	2.68	2.76	2.84	2.82	2.87	2.96	3.05	2.98	3.04	3.13	3.23	3.13	3.19	3.29	3.39	3.25	3.32	3.42	3.53	3.36	3.43	3.53	3.64
	Amps	9.6	9.8	10.1	10.5	10.3	10.6	10.9	11.3	11.2	11.5	11.8	12.3	12.0	12.2	12.6	13.1	12.7	13.0	13.4	13.9	13.4	13.8	14.2	14.7
	Hi PR	215	232	245	255	242	260	275	286	275	296	312	326	313	337	356	371	352	379	400	417	389	419	442	461
Lo PR	106	113	123	131	112	119	130	139	117	124	136	144	123	130	142	152	128	137	149	159	133	141	154	164	

IDB: Entering Indoor Dry Bulb Temperature  
 Shaded area reflects AHRI conditions  
 kW=Total system power  
 Amps = outdoor unit amps (comp.+fan)  
 Design Subcooling 9 ±3 °F @ the liquid service valve, AHRI 95 test conditions

EXPANDED COOLING DATA — MODEL: ASZ140481A\* / CA\*F4860\*6A\*+TXV / MBR2000\*\* -1

IDB*	Airflow	Outdoor Ambient Temperature																							
		65°F				75°F				85°F				95°F				105°F				115°F			
		59	63	67	71	59	63	67	71	59	63	67	71	59	63	67	71	59	63	67	71	59	63	67	71
70	MBh	45.1	46.7	51.2	-	44.0	45.6	50.0	-	43.0	44.5	48.8	-	41.9	43.5	47.6	-	39.8	41.3	45.2	-	36.9	38.2	41.9	-
	S/T	0.76	0.64	0.44	-	0.79	0.66	0.46	-	0.81	0.68	0.47	-	0.84	0.70	0.48	-	0.87	0.73	0.50	-	0.88	0.73	0.51	-
	ΔT	18	16	12	-	18	16	12	-	18	16	12	-	18	16	12	-	18	16	12	-	17	15	11	-
	kW	2.98	3.04	3.13	-	3.19	3.26	3.36	-	3.38	3.45	3.56	-	3.55	3.62	3.73	-	3.69	3.77	3.88	-	3.81	3.89	4.01	-
	Amps	5.9	6.2	6.5	-	6.8	7.0	7.4	-	7.7	8.0	8.5	-	8.6	8.9	9.4	-	9.5	9.8	10.3	-	10.3	10.7	11.2	-
	Hi PR	217	233	247	-	243	262	277	-	277	298	315	-	315	339	358	-	355	382	403	-	392	422	445	-
	Lo PR	106	113	123	-	112	119	130	-	116	124	135	-	122	130	142	-	128	136	149	-	132	141	154	-
	MBh	43.8	45.4	49.7	-	42.7	44.3	48.5	-	41.7	43.2	47.4	-	40.7	42.2	46.2	-	38.7	40.1	43.9	-	35.8	37.1	40.7	-
	S/T	0.73	0.61	0.42	-	0.75	0.63	0.44	-	0.77	0.65	0.45	-	0.80	0.67	0.46	-	0.83	0.69	0.48	-	0.84	0.70	0.48	-
	ΔT	19	16	12	-	19	17	13	-	19	17	13	-	19	17	13	-	19	16	12	-	18	15	12	-
	kW	2.96	3.02	3.10	-	3.17	3.23	3.33	-	3.36	3.42	3.53	-	3.52	3.59	3.70	-	3.66	3.74	3.85	-	3.78	3.86	3.98	-
	Amps	5.8	6.1	6.4	-	6.7	6.9	7.3	-	7.6	7.9	8.4	-	8.5	8.8	9.3	-	9.3	9.7	10.2	-	10.2	10.5	11.0	-
Hi PR	215	231	244	-	241	259	274	-	274	295	311	-	312	336	355	-	351	378	399	-	388	418	441	-	
Lo PR	105	112	122	-	111	118	129	-	115	122	134	-	121	129	140	-	127	135	147	-	131	139	152	-	
MBh	40.4	41.9	45.9	-	39.5	40.9	44.8	-	38.5	39.9	43.7	-	37.6	38.9	42.7	-	35.7	37.0	40.5	-	33.1	34.3	37.5	-	
S/T	0.70	0.59	0.41	-	0.73	0.61	0.42	-	0.75	0.62	0.43	-	0.77	0.64	0.45	-	0.80	0.67	0.46	-	0.81	0.67	0.47	-	
ΔT	19	17	13	-	19	17	13	-	19	17	13	-	20	17	13	-	20	17	13	-	18	16	12	-	
kW	2.89	2.95	3.04	-	3.10	3.16	3.25	-	3.28	3.34	3.45	-	3.44	3.51	3.62	-	3.57	3.65	3.76	-	3.69	3.77	3.89	-	
Amps	5.5	5.8	6.1	-	6.3	6.6	7.0	-	7.3	7.6	8.0	-	8.1	8.4	8.9	-	8.9	9.3	9.7	-	9.7	10.1	10.6	-	
Hi PR	208	224	237	-	234	252	266	-	266	286	302	-	303	326	344	-	341	367	387	-	376	405	428	-	
Lo PR	102	108	118	-	107	114	125	-	112	119	130	-	117	125	136	-	123	131	143	-	127	135	148	-	
75	MBh	45.8	47.2	51.1	54.8	44.8	46.1	49.9	53.6	43.7	45.0	48.7	52.3	42.6	43.9	47.5	51.0	40.5	41.7	45.1	48.5	37.5	38.6	41.8	44.9
	S/T	0.87	0.78	0.59	0.38	0.90	0.80	0.61	0.39	0.92	0.82	0.62	0.40	0.95	0.85	0.64	0.41	0.99	0.88	0.67	0.43	1.00	0.89	0.67	0.43
	ΔT	21	19	16	11	21	20	16	11	21	20	16	11	21	20	16	11	21	19	16	11	20	18	15	10
	kW	3.00	3.06	3.15	3.25	3.22	3.28	3.38	3.49	3.41	3.48	3.58	3.70	3.58	3.65	3.76	3.88	3.72	3.80	3.92	4.04	3.84	3.92	4.05	4.18
	Amps	6.0	6.3	6.6	7.0	6.9	7.1	7.5	8.0	7.9	8.2	8.6	9.1	8.7	9.1	9.5	10.0	9.6	9.9	10.4	11.0	10.4	10.8	11.3	11.9
	Hi PR	219	236	249	260	246	265	279	291	280	301	318	331	319	343	362	378	358	386	407	425	396	426	450	469
	Lo PR	107	114	124	132	113	120	131	140	117	125	136	145	123	131	143	153	129	138	150	160	134	142	155	165
	MBh	44.5	45.8	49.6	53.2	43.5	44.8	48.4	52.0	42.4	43.7	47.3	50.8	41.4	42.6	46.1	49.5	39.3	40.5	43.8	47.0	36.4	37.5	40.6	43.6
	S/T	0.83	0.74	0.56	0.36	0.86	0.77	0.58	0.37	0.88	0.79	0.59	0.38	0.91	0.81	0.61	0.40	0.94	0.84	0.64	0.41	0.95	0.85	0.64	0.41
	ΔT	22	20	16	11	22	20	17	12	22	20	17	12	22	21	17	12	22	20	17	11	21	19	15	11
	kW	2.98	3.04	3.13	3.22	3.19	3.26	3.36	3.46	3.38	3.45	3.56	3.67	3.55	3.62	3.73	3.85	3.69	3.77	3.88	4.01	3.81	3.89	4.01	4.14
	Amps	5.9	6.2	6.5	6.9	6.8	7.0	7.4	7.9	7.7	8.1	8.5	9.0	8.6	8.9	9.4	9.9	9.5	9.8	10.3	10.9	10.3	10.7	11.2	11.8
Hi PR	217	233	247	257	243	262	277	289	277	298	315	328	315	339	358	374	355	382	403	421	392	422	445	465	
Lo PR	106	113	123	131	112	119	130	138	116	124	135	144	122	130	142	151	128	136	149	158	132	141	154	164	
MBh	41.1	42.3	45.8	49.1	40.1	41.3	44.7	48.0	39.2	40.3	43.7	46.8	38.2	39.3	42.6	45.7	36.3	37.4	40.5	43.4	33.6	34.6	37.5	40.2	
S/T	0.80	0.71	0.54	0.35	0.83	0.74	0.56	0.36	0.85	0.76	0.57	0.37	0.87	0.78	0.59	0.38	0.91	0.81	0.61	0.40	0.92	0.82	0.62	0.40	
ΔT	22	20	17	12	22	21	17	12	22	21	17	12	23	21	17	12	23	21	17	12	21	19	16	11	
kW	2.91	2.97	3.06	3.15	3.12	3.18	3.28	3.38	3.30	3.37	3.47	3.58	3.46	3.54	3.65	3.76	3.60	3.68	3.79	3.91	3.72	3.80	3.92	4.04	
Amps	5.6	5.9	6.2	6.6	6.4	6.7	7.1	7.5	7.4	7.7	8.1	8.6	8.2	8.6	9.0	9.5	9.1	9.4	9.9	10.4	9.9	10.2	10.7	11.3	
Hi PR	210	226	239	249	236	254	268	280	269	289	305	318	306	329	348	363	344	370	391	408	380	409	432	451	
Lo PR	103	109	119	127	109	115	126	134	113	120	131	140	118	126	138	147	124	132	144	154	128	137	149	159	

IDB: Entering Indoor Dry Bulb Temperature  
 Shaded area reflects ACCA (TVA) conditions  
 kW=Total system power  
 Design Subcooling 9 ±3 °F @ the liquid service valve, AHRI 95 test conditions  
 Amps = outdoor unit amps (comp.+fan)

EXPANDED COOLING DATA — MODEL: ASZ140481A\* / CA\*F4860\*6A\*+TXV / MBR2000\*\* -1 (CONT.)

IDB*	Airflow	Outdoor Ambient Temperature																							
		65°F				75°F				85°F				95°F				105°F				115°F			
		59	63	67	71	59	63	67	71	59	63	67	71	59	63	67	71	59	63	67	71	59	63	67	71
80	MBh	46.7	47.7	50.9	54.4	45.6	46.6	49.7	53.2	44.5	45.5	48.6	51.9	43.4	44.3	47.4	50.6	41.2	42.1	45.0	48.1	38.2	39.0	41.7	44.6
	S/T	0.96	0.89	0.73	0.54	1.00	0.92	0.75	0.56	1.00	0.95	0.77	0.58	1.00	1.00	0.80	0.60	1.00	1.00	0.83	0.62	1.00	1.00	0.83	0.62
	ΔT	23	22	19	16	24	23	20	16	23	23	20	16	23	23	20	16	22	22	20	16	20	21	18	15
	KW	3.03	3.08	3.18	3.27	3.24	3.31	3.41	3.51	3.43	3.51	3.61	3.73	3.60	3.68	3.79	3.91	3.75	3.83	3.95	4.07	3.87	3.95	4.08	4.21
	Amps	6.1	6.4	6.7	7.1	7.0	7.3	7.6	8.1	8.0	8.3	8.7	9.2	8.8	9.2	9.6	10.2	9.7	10.1	10.6	11.2	10.6	11.0	11.5	12.1
	Hi PR	221	238	252	262	248	267	282	294	282	304	321	335	322	346	366	381	362	390	411	429	400	430	454	474
	Lo PR	108	115	125	134	114	121	133	141	119	126	138	147	125	133	145	154	131	139	152	162	135	144	157	167
	MBh	45.3	46.3	49.5	52.9	44.2	45.2	48.3	51.6	43.2	44.1	47.2	50.4	42.1	43.1	46.0	49.2	40.0	40.9	43.7	46.7	37.1	37.9	40.5	43.3
	S/T	0.91	0.85	0.69	0.52	0.94	0.88	0.72	0.54	0.96	0.90	0.74	0.55	0.99	0.93	0.76	0.57	1.00	0.97	0.79	0.59	1.00	0.98	0.79	0.59
	ΔT	24	23	20	16	25	24	21	16	25	24	21	16	25	24	21	17	24	23	20	16	22	22	19	15
KW	3.00	3.06	3.15	3.25	3.22	3.28	3.38	3.49	3.41	3.48	3.58	3.70	3.58	3.65	3.76	3.88	3.72	3.80	3.92	4.04	3.84	3.92	4.05	4.18	
Amps	6.0	6.3	6.6	7.0	6.9	7.1	7.5	8.0	7.9	8.2	8.6	9.1	8.7	9.1	9.5	10.1	9.6	9.9	10.4	11.0	10.4	10.8	11.3	11.9	
Hi PR	219	236	249	260	246	265	279	291	280	301	318	332	319	343	362	378	358	386	407	425	396	426	450	469	
Lo PR	107	114	124	132	113	120	131	140	117	125	136	145	123	131	143	153	129	138	150	160	134	142	155	165	
MBh	41.8	42.7	45.6	48.8	40.8	41.7	44.6	47.7	39.9	40.7	43.5	46.5	38.9	39.7	42.5	45.4	36.9	37.8	40.3	43.1	34.2	35.0	37.4	39.9	
S/T	0.87	0.82	0.67	0.50	0.91	0.85	0.69	0.52	0.93	0.87	0.71	0.53	0.96	0.90	0.73	0.55	1.00	0.93	0.76	0.57	1.00	0.94	0.77	0.57	
ΔT	25	24	21	17	25	24	21	17	25	24	21	17	25	24	21	17	25	24	21	17	23	22	19	16	
KW	2.94	2.99	3.08	3.17	3.14	3.21	3.30	3.40	3.33	3.40	3.50	3.61	3.49	3.56	3.67	3.79	3.63	3.71	3.82	3.94	3.75	3.83	3.95	4.08	
Amps	5.7	6.0	6.3	6.7	6.6	6.8	7.2	7.6	7.5	7.8	8.2	8.7	8.4	8.7	9.1	9.6	9.2	9.5	10.0	10.6	10.0	10.4	10.9	11.5	
Hi PR	213	229	242	252	239	257	271	283	271	292	308	322	309	333	351	366	348	374	395	412	384	413	436	455	
Lo PR	104	110	121	128	110	117	127	136	114	121	132	141	120	127	139	148	125	133	146	155	130	138	151	160	

85	MBh	47.5	48.4	50.7	54.1	46.4	47.3	49.5	52.8	45.3	46.1	48.3	51.6	44.2	45.0	47.1	50.3	42.0	42.8	44.8	47.8	38.9	39.6	41.5	44.3
	S/T	1.00	0.96	0.87	0.70	1.00	1.00	0.90	0.73	1.00	1.00	0.92	0.75	1.00	1.00	0.95	0.77	1.00	1.00	0.99	0.80	1.00	1.00	1.00	0.81
	ΔT	25	25	23	20	24	25	23	20	24	24	24	20	23	24	24	20	22	23	23	20	20	21	22	19
	KW	3.05	3.11	3.20	3.30	3.27	3.33	3.43	3.54	3.46	3.53	3.64	3.76	3.63	3.71	3.82	3.95	3.78	3.86	3.98	4.11	3.90	3.99	4.11	4.25
	Amps	6.2	6.5	6.8	7.2	7.1	7.4	7.8	8.2	8.1	8.4	8.8	9.4	9.0	9.3	9.8	10.3	9.9	10.2	10.7	11.3	10.7	11.1	11.6	12.3
	Hi PR	224	241	254	265	251	270	285	297	285	307	324	338	325	350	369	385	366	393	415	433	404	435	459	479
	Lo PR	109	116	127	135	115	123	134	143	120	127	139	148	126	134	146	156	132	140	153	163	136	145	158	169
	MBh	46.1	47.0	49.2	52.5	45.0	45.9	48.1	51.3	43.9	44.8	46.9	50.1	42.9	43.7	45.8	48.8	40.7	41.5	43.5	46.4	37.7	38.5	40.3	43.0
	S/T	0.95	0.92	0.83	0.67	0.99	0.95	0.86	0.70	1.00	0.97	0.88	0.71	1.00	1.00	0.91	0.74	1.00	1.00	0.94	0.76	1.00	1.00	0.95	0.77
	ΔT	26	26	24	21	26	26	24	21	26	26	24	21	25	26	25	21	24	25	24	21	22	23	23	20
KW	3.03	3.08	3.18	3.27	3.24	3.31	3.41	3.51	3.43	3.51	3.61	3.73	3.60	3.68	3.79	3.91	3.75	3.83	3.95	4.07	3.87	3.95	4.08	4.21	
Amps	6.1	6.4	6.7	7.1	7.0	7.3	7.6	8.1	8.0	8.3	8.7	9.2	8.8	9.2	9.6	10.2	9.7	10.1	10.6	11.2	10.6	11.0	11.5	12.1	
Hi PR	221	238	252	262	248	267	282	294	282	304	321	335	322	346	366	381	362	390	411	429	400	430	454	474	
Lo PR	108	115	125	134	114	121	133	141	119	126	138	147	125	133	145	154	131	139	152	162	135	144	157	167	
MBh	42.5	43.4	45.4	48.5	41.5	42.4	44.4	47.3	40.6	41.3	43.3	46.2	39.6	40.3	42.2	45.1	37.6	38.3	40.1	42.8	34.8	35.5	37.2	39.7	
S/T	0.92	0.88	0.80	0.65	0.95	0.92	0.83	0.67	0.97	0.94	0.85	0.69	1.00	0.97	0.88	0.71	1.00	1.00	0.91	0.74	1.00	1.00	0.92	0.74	
ΔT	26	26	25	21	27	26	25	22	27	26	25	22	27	27	25	22	25	26	25	21	24	24	23	20	
KW	2.96	3.02	3.10	3.20	3.17	3.23	3.33	3.43	3.35	3.42	3.53	3.64	3.52	3.59	3.70	3.82	3.66	3.74	3.85	3.97	3.78	3.86	3.98	4.11	
Amps	5.8	6.1	6.4	6.8	6.7	6.9	7.3	7.8	7.6	7.9	8.3	8.8	8.5	8.8	9.2	9.8	9.3	9.7	10.1	10.7	10.2	10.5	11.0	11.6	
Hi PR	215	231	244	254	241	259	274	286	274	295	311	325	312	336	355	370	351	378	399	416	388	417	441	460	
Lo PR	105	111	122	130	111	118	129	137	115	122	134	142	121	129	140	150	127	135	147	157	131	139	152	162	

IDB: Entering Indoor Dry Bulb Temperature  
 Shaded area reflects AHRl conditions  
 kW=Total system power  
 Design Subcooling 9 ±3 °F @ the liquid service valve, AHRl 95 test conditions  
 Amps = outdoor unit amps (comp.+fan)

EXPANDED COOLING DATA — MODEL: ASZ140601A\* / CA\*F4860\*6A\*+TXV / MBE2000\*\* -1

IDB*	Airflow	Outdoor Ambient Temperature																							
		65°F				75°F				85°F				95°F				105°F				115°F			
		59	63	67	71	59	63	67	71	59	63	67	71	59	63	67	71	59	63	67	71	59	63	67	71
70	MBh	55.4	57.4	62.9	-	54.1	56.1	61.4	-	52.8	54.7	59.9	-	51.5	53.4	58.5	-	48.9	50.7	55.6	-	45.3	47.0	51.5	-
	S/T	0.74	0.62	0.43	-	0.77	0.64	0.45	-	0.79	0.66	0.46	-	0.81	0.68	0.47	-	0.85	0.71	0.49	-	0.85	0.71	0.49	-
	ΔT	18	16	12	-	18	16	12	-	18	16	12	-	19	16	12	-	19	16	12	-	17	15	11	-
	KW	3.63	3.70	3.82	-	3.91	3.99	4.12	-	4.16	4.25	4.39	-	4.38	4.48	4.63	-	4.57	4.67	4.83	-	4.73	4.83	5.00	-
	Amps	7.6	7.9	8.4	-	8.7	9.1	9.6	-	10.0	10.4	10.9	-	11.1	11.5	12.1	-	12.2	12.7	13.3	-	13.3	13.8	14.5	-
	Hi PR	219	236	249	-	246	264	279	-	279	301	318	-	318	343	362	-	358	385	407	-	396	426	450	-
	Lo PR	103	110	120	-	109	116	126	-	113	120	131	-	119	126	138	-	125	132	145	-	129	137	150	-
	MBh	53.8	55.7	61.0	-	52.5	54.4	59.6	-	51.3	53.1	58.2	-	50.0	51.8	56.8	-	47.5	49.2	53.9	-	44.0	45.6	50.0	-
	S/T	0.71	0.59	0.41	-	0.73	0.61	0.42	-	0.75	0.63	0.44	-	0.78	0.65	0.45	-	0.81	0.67	0.47	-	0.81	0.68	0.47	-
	ΔT	19	16	12	-	19	17	13	-	19	17	13	-	19	17	13	-	19	16	13	-	18	15	12	-
KW	3.60	3.67	3.79	-	3.88	3.96	4.09	-	4.12	4.22	4.35	-	4.34	4.44	4.59	-	4.53	4.63	4.78	-	4.69	4.79	4.96	-	
Amps	7.4	7.8	8.2	-	8.6	8.9	9.4	-	9.8	10.2	10.8	-	11.0	11.4	12.0	-	12.1	12.5	13.1	-	13.2	13.6	14.3	-	
Hi PR	217	233	246	-	243	262	276	-	277	298	314	-	315	339	358	-	355	382	403	-	392	422	445	-	
Lo PR	102	108	118	-	108	115	125	-	112	119	130	-	118	125	137	-	123	131	143	-	128	136	148	-	
MBh	49.6	51.4	56.3	-	48.5	50.2	55.0	-	47.3	49.0	53.7	-	46.2	47.8	52.4	-	43.8	45.4	49.8	-	40.6	42.1	46.1	-	
S/T	0.68	0.57	0.40	-	0.71	0.59	0.41	-	0.73	0.61	0.42	-	0.75	0.63	0.43	-	0.78	0.65	0.45	-	0.78	0.65	0.45	-	
ΔT	19	17	13	-	19	17	13	-	19	17	13	-	20	17	13	-	19	17	13	-	18	16	12	-	
KW	3.51	3.58	3.70	-	3.78	3.86	3.99	-	4.02	4.11	4.24	-	4.23	4.33	4.47	-	4.41	4.51	4.66	-	4.57	4.67	4.83	-	
Amps	7.1	7.4	7.8	-	8.2	8.5	9.0	-	9.4	9.8	10.3	-	10.5	10.9	11.5	-	11.6	12.0	12.6	-	12.6	13.1	13.7	-	
Hi PR	210	226	239	-	236	254	268	-	268	289	305	-	306	329	347	-	344	370	391	-	380	409	432	-	
Lo PR	99	105	115	-	105	111	121	-	109	116	126	-	114	121	133	-	120	127	139	-	124	132	144	-	

75	MBh	56.3	58.0	62.7	67.3	55.0	56.6	61.3	65.8	53.7	55.3	59.8	64.2	52.4	53.9	58.4	62.6	49.8	51.2	55.5	59.5	46.1	47.5	51.4	55.1
	S/T	0.84	0.75	0.57	0.37	0.87	0.78	0.59	0.38	0.90	0.80	0.61	0.39	0.93	0.83	0.63	0.40	0.96	0.86	0.65	0.42	0.97	0.87	0.66	0.42
	ΔT	21	19	16	11	21	20	16	11	21	20	16	11	21	20	16	11	21	19	16	11	20	18	15	10
	KW	3.66	3.73	3.85	3.98	3.94	4.03	4.16	4.30	4.19	4.29	4.43	4.58	4.42	4.52	4.67	4.82	4.61	4.71	4.87	5.03	4.77	4.88	5.04	5.22
	Amps	7.7	8.0	8.5	9.1	8.8	9.2	9.7	10.3	10.1	10.5	11.1	11.8	11.3	11.7	12.3	13.0	12.4	12.9	13.5	14.3	13.5	14.0	14.7	15.5
	Hi PR	221	238	251	262	248	267	282	294	282	304	321	335	322	346	365	381	362	389	411	429	400	430	454	474
	Lo PR	104	111	121	129	110	117	128	136	114	122	133	141	120	128	139	148	126	134	146	156	130	138	151	161
	MBh	54.7	56.3	60.9	65.4	53.4	55.0	59.5	63.9	52.1	53.7	58.1	62.3	50.9	52.4	56.7	60.8	48.3	49.7	53.8	57.8	44.7	46.1	49.9	53.5
	S/T	0.80	0.72	0.54	0.35	0.83	0.75	0.56	0.36	0.86	0.77	0.58	0.37	0.88	0.79	0.60	0.38	0.92	0.82	0.62	0.40	0.92	0.83	0.63	0.40
	ΔT	22	20	16	11	22	20	17	12	22	20	17	12	22	21	17	12	22	20	17	11	21	19	16	11
KW	3.63	3.70	3.82	3.95	3.91	3.99	4.12	4.26	4.16	4.25	4.39	4.54	4.38	4.48	4.63	4.78	4.57	4.67	4.83	4.99	4.73	4.84	5.00	5.17	
Amps	7.6	7.9	8.4	8.9	8.7	9.1	9.6	10.2	10.0	10.4	10.9	11.6	11.1	11.5	12.1	12.8	12.2	12.7	13.3	14.1	13.3	13.8	14.5	15.3	
Hi PR	219	236	249	260	246	265	279	291	280	301	318	331	318	343	362	377	358	385	407	425	396	426	450	469	
Lo PR	103	110	120	127	109	116	126	135	113	120	131	140	119	126	138	147	125	132	145	154	129	137	150	159	
MBh	50.5	51.9	56.2	60.3	49.3	50.7	54.9	58.9	48.1	49.5	53.6	57.5	46.9	48.3	52.3	56.1	44.6	45.9	49.7	53.3	41.3	42.5	46.0	49.4	
S/T	0.78	0.69	0.53	0.34	0.80	0.72	0.54	0.35	0.82	0.74	0.56	0.36	0.85	0.76	0.58	0.37	0.88	0.79	0.60	0.38	0.89	0.80	0.60	0.39	
ΔT	22	20	17	12	23	21	17	12	23	21	17	12	23	21	17	12	23	21	17	12	21	19	16	11	
KW	3.54	3.61	3.73	3.85	3.81	3.90	4.02	4.15	4.06	4.14	4.28	4.42	4.27	4.36	4.51	4.66	4.45	4.55	4.70	4.86	4.61	4.71	4.87	5.04	
Amps	7.2	7.5	8.0	8.5	8.3	8.6	9.1	9.7	9.5	9.9	10.5	11.1	10.6	11.0	11.6	12.3	11.7	12.2	12.8	13.5	12.8	13.3	13.9	14.7	
Hi PR	212	229	241	252	238	257	271	283	271	292	308	321	309	332	351	366	347	374	395	412	384	413	436	455	
Lo PR	100	106	116	124	106	112	123	131	110	117	127	136	115	123	134	143	121	129	140	149	125	133	145	155	

IDB: Entering Indoor Dry Bulb Temperature  
 Shaded area reflects ACCA (TVA) conditions  
 kW=Total system power  
 Amps = outdoor unit amps (comp.+fan)  
 Design Subcooling 9 ±3 °F @ the liquid service valve, AHRI 95 test conditions



EXPANDED COOLING DATA — MODEL: ASZ140601A\* / CA\*F4860\*6A\*+TXV / MBE2000\*\* -1 (CONT.)

IDB*	Airflow	Outdoor Ambient Temperature																							
		65°F				75°F				85°F				95°F				105°F				115°F			
		59	63	67	71	59	63	67	71	59	63	67	71	59	63	67	71	59	63	67	71	59	63	67	71
80	MBh	57.3	58.6	62.6	66.9	56.0	57.2	61.1	65.3	54.6	55.8	59.6	63.8	53.3	54.5	58.2	62.2	50.6	51.7	55.3	59.1	46.9	47.9	51.2	54.7
	S/T	0.93	0.87	0.71	0.53	0.96	0.90	0.73	0.55	1.00	0.92	0.75	0.56	1.00	0.95	0.78	0.58	1.00	1.00	0.80	0.60	1.00	1.00	0.81	0.61
	ΔT	23	22	20	16	24	23	20	16	24	23	20	16	24	23	20	16	24	23	20	16	21	21	18	15
	KW	3.69	3.76	3.89	4.01	3.97	4.06	4.19	4.33	4.23	4.32	4.47	4.62	4.45	4.55	4.71	4.87	4.64	4.75	4.91	5.08	4.81	4.92	5.09	5.26
	Amps	7.8	8.2	8.6	9.2	9.0	9.3	9.9	10.5	10.3	10.7	11.3	11.9	11.4	11.9	12.5	13.2	12.6	13.0	13.7	14.5	13.7	14.2	14.9	15.7
	Hi PR	223	240	254	265	251	270	285	297	285	307	324	338	325	350	369	385	365	393	415	433	404	434	459	479
	Lo PR	105	112	122	130	111	118	129	137	115	123	134	143	121	129	141	150	127	135	148	157	131	140	153	163
	MBh	55.6	56.9	60.7	64.9	54.3	55.5	59.3	63.4	53.0	54.2	57.9	61.9	51.8	52.9	56.5	60.4	49.2	50.2	53.7	57.4	45.5	46.5	49.7	53.2
	S/T	0.88	0.83	0.67	0.50	0.91	0.86	0.70	0.52	0.94	0.88	0.72	0.54	0.97	0.91	0.74	0.55	1.00	0.94	0.77	0.57	1.00	0.95	0.77	0.58
	ΔT	24	23	20	16	25	24	21	16	25	24	21	16	25	24	21	17	24	24	20	16	23	22	19	15
KW	3.66	3.73	3.85	3.98	3.94	4.03	4.16	4.30	4.19	4.29	4.43	4.58	4.42	4.52	4.67	4.82	4.61	4.71	4.87	5.03	4.77	4.88	5.04	5.22	
Amps	7.7	8.0	8.5	9.1	8.8	9.2	9.7	10.3	10.1	10.5	11.1	11.8	11.3	11.7	12.3	13.0	12.4	12.9	13.5	14.3	13.5	14.0	14.7	15.5	
Hi PR	221	238	251	262	248	267	282	294	282	304	321	335	322	346	365	381	362	389	411	429	400	430	454	474	
Lo PR	104	111	121	129	110	117	128	136	114	122	133	141	120	128	139	148	126	134	146	156	130	138	151	161	
MBh	51.4	52.5	56.1	59.9	50.2	51.3	54.8	58.5	49.0	50.0	53.5	57.1	47.8	48.8	52.1	55.7	45.4	46.4	49.5	53.0	42.0	43.0	45.9	49.1	
S/T	0.85	0.80	0.65	0.49	0.88	0.83	0.67	0.50	0.90	0.85	0.69	0.52	0.93	0.88	0.71	0.53	0.97	0.91	0.74	0.55	0.98	0.92	0.75	0.56	
ΔT	25	24	21	17	25	24	21	17	25	24	21	17	25	24	21	17	25	24	21	17	23	22	19	16	
KW	3.57	3.64	3.76	3.88	3.84	3.93	4.06	4.19	4.09	4.18	4.32	4.46	4.31	4.40	4.55	4.70	4.49	4.59	4.74	4.90	4.65	4.75	4.91	5.08	
Amps	7.3	7.6	8.1	8.6	8.4	8.8	9.3	9.9	9.7	10.1	10.6	11.3	10.8	11.2	11.8	12.5	11.9	12.3	13.0	13.7	13.0	13.4	14.1	14.9	
Hi PR	215	231	244	254	241	259	274	285	274	295	311	325	312	336	354	370	351	378	399	416	388	417	441	460	
Lo PR	101	107	117	125	107	113	124	132	111	118	129	137	116	124	135	144	122	130	142	151	126	134	147	156	

85	MBh	58.3	59.4	62.2	66.4	56.9	58.1	60.8	64.9	55.6	56.7	59.4	63.3	54.2	55.3	57.9	61.8	51.5	52.5	55.0	58.7	47.7	48.7	51.0	54.4
	S/T	0.97	0.94	0.85	0.69	1.00	0.97	0.88	0.71	1.00	1.00	0.90	0.73	1.00	1.00	0.93	0.75	1.00	1.00	0.96	0.78	1.00	1.00	0.97	0.79
	ΔT	25	25	23	20	25	25	24	20	25	25	24	20	24	24	24	21	23	23	23	20	21	21	22	19
	KW	3.72	3.80	3.92	4.05	4.01	4.09	4.23	4.37	4.26	4.36	4.50	4.66	4.49	4.59	4.75	4.91	4.68	4.79	4.95	5.12	4.85	4.96	5.13	5.31
	Amps	8.0	8.3	8.8	9.3	9.1	9.5	10.0	10.6	10.4	10.9	11.4	12.1	11.6	12.0	12.7	13.4	12.8	13.2	13.9	14.7	13.9	14.4	15.1	15.9
	Hi PR	226	243	256	268	253	273	288	300	288	310	327	341	328	353	373	389	369	397	419	437	408	439	463	483
	Lo PR	106	113	123	131	112	119	130	139	117	124	135	144	122	130	142	151	128	137	149	159	133	141	154	164
	MBh	56.6	57.7	60.4	64.5	55.3	56.4	59.0	63.0	54.0	55.0	57.6	61.5	52.7	53.7	56.2	60.0	50.0	51.0	53.4	57.0	46.3	47.2	49.5	52.8
	S/T	0.93	0.89	0.81	0.65	0.96	0.93	0.84	0.68	0.98	0.95	0.86	0.69	1.00	0.98	0.88	0.72	1.00	1.00	0.92	0.74	1.00	1.00	0.93	0.75
	ΔT	26	26	24	21	26	26	25	21	26	26	25	21	26	26	25	21	26	26	25	21	23	23	23	20
KW	3.69	3.76	3.89	4.01	3.97	4.06	4.19	4.33	4.23	4.32	4.47	4.62	4.45	4.55	4.71	4.87	4.64	4.75	4.91	5.08	4.81	4.92	5.09	5.26	
Amps	7.8	8.2	8.6	9.2	9.0	9.3	9.9	10.5	10.3	10.7	11.3	11.9	11.4	11.9	12.5	13.2	12.6	13.0	13.7	14.5	13.7	14.2	14.9	15.7	
Hi PR	223	240	254	265	251	270	285	297	285	307	324	338	325	350	369	385	365	393	415	433	404	434	459	479	
Lo PR	105	112	122	130	111	118	129	137	115	123	134	143	121	129	141	150	127	135	148	157	131	140	153	163	
MBh	52.2	53.3	55.8	59.5	51.0	52.0	54.5	58.1	49.8	50.8	53.2	56.7	48.6	49.5	51.9	55.4	46.2	47.1	49.3	52.6	42.8	43.6	45.7	48.7	
S/T	0.89	0.86	0.78	0.63	0.92	0.89	0.81	0.65	0.95	0.92	0.83	0.67	0.98	0.94	0.85	0.69	1.00	0.98	0.88	0.72	1.00	0.99	0.89	0.72	
ΔT	26	26	25	21	27	26	25	22	27	26	25	22	27	27	25	22	26	26	25	21	24	24	23	20	
KW	3.60	3.67	3.79	3.91	3.88	3.96	4.09	4.22	4.12	4.21	4.35	4.50	4.34	4.44	4.59	4.74	4.53	4.63	4.78	4.95	4.69	4.79	4.95	5.12	
Amps	7.4	7.8	8.2	8.8	8.6	8.9	9.4	10.0	9.8	10.2	10.8	11.4	10.9	11.4	12.0	12.6	12.1	12.5	13.1	13.9	13.1	13.6	14.3	15.1	
Hi PR	217	233	246	257	243	262	276	288	277	298	314	328	315	339	358	373	354	381	403	420	392	421	445	464	
Lo PR	102	108	118	126	108	115	125	133	112	119	130	138	118	125	137	145	123	131	143	152	127	136	148	158	

IDB: Entering Indoor Dry Bulb Temperature  
 Shaded area reflects AHRl conditions  
 kW=Total system power  
 Design Subcooling 9 ±3 °F @ the liquid service valve, AHRl 95 test conditions  
 Amps = outdoor unit amps (comp.+fan)

## PRODUCT SPECIFICATIONS

### EXPANDED HEATING DATA

Model: ASZ140181A\* / CA\*F3131\*6A\* +TXV / MBR800\*\*-1

	Outdoor Ambient Temperature																	
	65	60	55	50	47	45	40	35	30	25	20	17	15	10	5	0	-5	-10
MBh	22.6	21.4	20.2	18.8	18.0	17.4	16.2	14.9	12.8	11.8	10.9	10.3	9.9	8.9	7.9	6.9	5.9	4.8
ΔT	34.9	33.1	31.1	29.1	27.8	26.9	25.0	23.1	19.7	18.2	16.8	15.8	15.3	13.7	12.1	10.6	9.0	7.4
kW	1.56	1.53	1.50	1.47	1.45	1.44	1.41	1.38	1.39	1.36	1.32	1.31	1.29	1.26	1.23	1.20	1.17	1.14
Amps	7.0	6.5	6.1	5.7	5.5	5.4	5.1	4.9	4.7	4.5	4.2	4.1	4.1	3.9	3.6	3.4	3.2	2.9
COP	4.23	4.09	3.93	3.75	3.62	3.54	3.36	3.16	2.70	2.55	2.40	2.30	2.24	2.06	1.87	1.67	1.47	1.23
EER	14.5	14.0	13.4	12.8	12.4	12.1	11.5	10.8	9.2	8.7	8.2	7.9	7.6	7.0	6.4	5.7	5.0	4.2
Hi PR	385	369	355	339	331	325	312	300	287	274	263	257	252	243	234	224	216	208
Lo PR	149	138	129	118	112	108	99	88	80	71	62	58	56	47	41	34	30	24

High pressure is measured at the suction service valve (the larger valve).

Amps = Outdoor unit amps (comp.+fan)

Low pressure is measured at the gauge port connection.

kW = Total system power

Calculations are based on nominal CFM and 70°F indoor dry bulb.

Model: ASZ140241A\* / CA\*F3636\*6A\*+TXV / MBR800\*\*-1

	Outdoor Ambient Temperature																	
	65	60	55	50	47	45	40	35	30	25	20	17	15	10	5	0	-5	-10
MBh	30.2	28.6	26.9	25.1	24.0	23.3	21.6	19.9	17.9	16.6	15.2	14.4	13.9	12.4	11.0	9.6	8.2	6.7
ΔT	32.9	31.1	29.3	27.4	26.1	25.3	23.5	21.7	19.5	18.0	16.6	15.7	15.1	13.5	12.0	10.5	8.9	7.3
kW	2.08	2.04	2.00	1.96	1.94	1.92	1.89	1.85	1.87	1.82	1.78	1.76	1.74	1.70	1.66	1.62	1.58	1.54
Amps	8.1	7.9	7.7	7.5	7.4	7.3	7.2	7.1	7.0	6.9	6.8	6.7	6.7	6.6	6.5	6.3	6.2	6.1
COP	4.24	4.09	3.93	3.74	3.62	3.54	3.35	3.16	2.81	2.65	2.50	2.39	2.33	2.14	1.94	1.73	1.52	1.28
EER	14.5	14.0	13.4	12.8	12.4	12.1	11.4	10.8	9.6	9.1	8.5	8.2	7.9	7.3	6.6	5.9	5.2	4.4
Hi PR	373	358	344	329	321	315	303	290	278	266	255	249	245	235	226	217	209	202
Lo PR	143	133	124	114	108	104	95	85	77	68	60	56	54	46	39	33	29	23

High pressure is measured at the suction service valve (the larger valve).

Amps = Outdoor unit amps (comp.+fan)

Low pressure is measured at the gauge port connection.

kW = Total system power

Calculations are based on nominal CFM and 70°F indoor dry bulb.

Model: ASZ140301A\* / CA\*F3642\*6A\*+TXV / MBR1600\*\*-1

	Outdoor Ambient Temperature																	
	65	60	55	50	47	45	40	35	30	25	20	17	15	10	5	0	-5	-10
MBh	36.5	34.5	32.5	30.4	29.0	28.1	26.1	24.1	22.6	20.9	19.2	18.2	17.5	15.7	13.9	12.1	10.3	8.5
ΔT	32.1	30.4	28.6	26.8	25.6	24.8	23.0	21.2	19.9	18.4	17.0	16.0	15.4	13.8	12.3	10.7	9.1	7.5
kW	2.40	2.36	2.32	2.27	2.25	2.23	2.19	2.14	2.20	2.15	2.11	2.08	2.06	2.01	1.97	1.92	1.87	1.83
Amps	11.8	10.6	9.6	8.7	8.2	8.0	7.2	6.6	6.1	5.6	5.1	4.9	4.8	4.3	3.6	3.1	2.5	1.8
COP	4.44	4.28	4.10	3.91	3.78	3.69	3.50	3.29	3.01	2.84	2.67	2.55	2.48	2.28	2.07	1.85	1.62	1.36
EER	15.2	14.6	14.0	13.4	12.9	12.6	11.9	11.2	10.3	9.7	9.1	8.7	8.5	7.8	7.1	6.3	5.5	4.6
Hi PR	360	346	332	318	310	304	292	281	269	257	247	241	236	227	219	210	202	195
Lo PR	137	127	119	110	104	100	92	82	74	66	58	54	52	44	38	32	28	22

High pressure is measured at the suction service valve (the larger valve).

Amps = Outdoor unit amps (comp.+fan)

Low pressure is measured at the gauge port connection.

kW = Total system power

Calculations are based on nominal CFM and 70°F indoor dry bulb.

## EXPANDED HEATING DATA (CONT.)

Model: ASZ140361A\* / CA\*F4860\*6A\*+TXV / MBR1600\*\*-1

	Outdoor Ambient Temperature																	
	65	60	55	50	47	45	40	35	30	25	20	17	15	10	5	0	-5	-10
MBh	43.5	41.2	38.8	36.2	<b>34.6</b>	33.5	31.1	28.7	28.8	26.6	24.5	23.1	22.3	20.0	17.7	15.5	13.2	10.8
ΔT	38.4	36.3	34.2	31.9	30.5	29.6	27.5	25.3	25.4	23.5	21.6	20.4	19.6	17.6	15.6	13.6	11.6	9.5
kW	3.05	2.99	2.94	2.88	<b>2.84</b>	2.82	2.76	2.71	2.78	2.72	2.66	2.62	2.60	2.53	2.47	2.41	2.35	2.29
Amps	13.8	12.8	12.0	11.3	10.9	10.7	10.1	9.6	9.2	8.9	8.4	8.3	8.2	7.8	7.3	6.9	6.4	5.8
COP	4.17	4.02	3.86	3.68	3.56	3.48	3.30	3.11	3.03	2.86	2.70	2.58	2.51	2.31	2.10	1.87	1.64	1.38
EER	14.3	13.8	13.2	12.6	12.2	11.9	11.3	10.6	10.4	9.8	9.2	8.8	8.6	7.9	7.2	6.4	5.6	4.7
Hi PR	384	368	353	338	330	324	311	299	286	273	262	256	251	242	233	223	215	208
Lo PR	144	134	125	115	109	105	96	86	77	69	61	56	54	46	40	33	29	23

High pressure is measured at the suction service valve (the larger valve).  
 Low pressure is measured at the gauge port connection.  
 Calculations are based on nominal CFM and 70°F indoor dry bulb.

Amps = Outdoor unit amps (comp.+fan)  
 kW = Total system power

Model: ASZ140421A\* / CA\*F4860\*6A\*+TXV / MBR2000\*\*-1

	Outdoor Ambient Temperature																	
	65	60	55	50	47	45	40	35	30	25	20	17	15	10	5	0	-5	-10
MBh	51.5	48.8	45.9	42.9	<b>41.0</b>	39.7	36.9	34.0	34.3	31.6	29.1	27.5	26.5	23.8	21.1	18.4	15.7	12.8
ΔT	34.1	32.3	30.4	28.4	27.1	26.3	24.4	22.5	22.7	20.9	19.3	18.2	17.5	15.7	13.9	12.1	10.4	8.5
kW	3.40	3.33	3.27	3.21	<b>3.17</b>	3.14	3.08	3.02	3.07	3.00	2.94	2.90	2.87	2.81	2.74	2.68	2.61	2.54
Amps	15.2	14.1	13.2	12.4	12.0	11.8	11.1	10.6	10.1	9.7	9.2	9.0	8.9	8.5	7.9	7.5	6.9	6.3
COP	4.44	4.28	4.11	3.92	3.79	3.70	3.50	3.30	3.26	3.08	2.90	2.78	2.70	2.48	2.25	2.01	1.76	1.48
EER	15.2	14.6	14.0	13.4	12.9	12.6	12.0	11.3	11.2	10.5	9.9	9.5	9.2	8.5	7.7	6.9	6.0	5.1
Hi PR	370	354	341	326	318	312	300	288	276	263	253	247	242	233	224	215	207	200
Lo PR	142	132	123	113	107	103	95	84	76	68	60	56	53	45	39	33	29	23

Model: ASZ140481A\* / CA\*F4860\*6A\*+TXV / MBR2000\*\*-1

	Outdoor Ambient Temperature																	
	65	60	55	50	47	45	40	35	30	25	20	17	15	10	5	0	-5	-10
MBh	57.8	54.7	51.5	48.2	46.0	44.6	41.4	38.2	36.6	33.8	31.1	29.4	28.3	25.4	22.5	19.6	16.8	13.7
ΔT	34.5	32.7	30.8	28.8	27.5	26.6	24.7	22.8	21.9	20.2	18.6	17.6	16.9	15.2	13.4	11.7	10.0	8.2
kW	3.98	3.90	3.83	3.75	<b>3.71</b>	3.68	3.60	3.53	3.65	3.57	3.49	3.44	3.41	3.32	3.24	3.16	3.08	3.00
Amps	19.4	17.6	16.1	14.8	14.1	13.7	12.7	11.7	11.0	10.3	9.5	9.2	9.0	8.3	7.4	6.6	5.7	4.6
COP	4.25	4.10	3.94	3.76	3.63	3.55	3.36	3.17	2.94	2.77	2.61	2.50	2.43	2.24	2.03	1.82	1.59	1.34
EER	14.5	14.0	13.5	12.8	12.4	12.1	11.5	10.8	10.0	9.5	8.9	8.5	8.3	7.6	6.9	6.2	5.4	4.6
Hi PR	408	391	376	359	351	344	331	318	304	291	279	272	267	257	247	237	229	221
Lo PR	136	126	118	109	103	99	91	81	73	65	57	53	51	43	37	32	28	22

High pressure is measured at the suction service valve (the larger valve).  
 Low pressure is measured at the gauge port connection.  
 Calculations are based on nominal CFM and 70°F indoor dry bulb.

Amps = Outdoor unit amps (comp.+fan)  
 kW = Total system power

Model: ASZ140601A\* / CA\*F4860\*6A\*+TXV / MBE2000\*\*-1

	Outdoor Ambient Temperature																	
	65	60	55	50	47	45	40	35	30	25	20	17	15	10	5	0	-5	-10
MBh	71.6	67.8	63.8	59.7	<b>57.0</b>	55.2	51.3	47.3	47.9	44.2	40.7	38.4	37.0	33.2	29.4	25.7	21.9	17.9
ΔT	35.9	33.9	32.0	29.9	28.5	27.6	25.7	23.7	24.0	22.1	20.4	19.2	18.5	16.6	14.7	12.8	11.0	9.0
kW	4.83	4.74	4.64	4.54	<b>4.48</b>	4.44	4.35	4.25	4.42	4.32	4.21	4.15	4.11	4.00	3.90	3.80	3.69	3.59
Amps	24.7	22.3	20.4	18.8	17.9	17.4	16.0	14.8	13.9	12.9	12.0	11.5	11.3	10.4	9.2	8.2	7.1	5.7
COP	4.34	4.19	4.03	3.85	3.72	3.64	3.45	3.26	3.17	2.99	2.83	2.71	2.63	2.43	2.21	1.98	1.74	1.46
EER	14.8	14.3	13.8	13.1	12.7	12.4	11.8	11.1	10.8	10.2	9.7	9.3	9.0	8.3	7.5	6.8	5.9	5.0
Hi PR	404	387	372	356	347	341	327	314	301	288	276	269	265	255	245	235	226	218
Lo PR	136	126	119	109	103	99	91	81	73	65	57	53	51	43	37	32	28	22

# AHRI PERFORMANCE RATINGS

Outdoor Unit	Indoor Units		Cooling Capacity (BTU/h)				TVA Ratings <sup>3</sup>		Heating Capacity (BTU/h)		AHRI #
	Coil & Blower Units	Furnace	Total	Sens.	SEER <sup>1</sup>	EER <sup>2</sup>	Total	Sens.	High	HSPF <sup>4</sup>	
ASZ14 0181A*	AEPF183016C*+TXV		19,000	13,900	15.0	13.0	17,600	13,700	18,000	8.50	10,400
	AR*F193116B*+TXV		19,000	13,900	14.5	12.5	17,600	13,700	18,000	8.50	10,000
	ASPF183016B*+TXV		19,000	13,900	15.0	13.0	17,600	13,700	18,000	8.50	10,400
	CA*F3131*6B*+EEP+TXV		19,000	13,900	14.0	12.0	17,600	13,700	18,000	8.30	10,600
	CA*F3131*6B*+MBE1200**,-1+TXV		18,000	13,100	15.0	12.5	16,700	13,000	18,000	8.10	10,200
	CA*F3131*6B*+MBR0800**,-1+TXV	A*V90453B**	18,000	13,100	14.0	12.0	16,700	13,000	18,000	8.50	10,800
	CA*F3131*6B*+TXV	G*V950453B**	18,000	13,100	15.0	12.5	16,700	13,000	18,000	8.10	10,200
	CA*F3131*6B*+TXV	A*V80704B**	18,000	13,100	15.0	12.5	16,700	13,000	18,000	8.10	10,200
	CA*F3131*6C*+EEP+TXV		19,000	13,900	14.0	12.0	17,600	13,700	18,000	8.30	10,600
	CA*F3131*6C*+MBE1200**,-1+TXV		18,000	13,100	15.0	12.5	16,700	13,000	18,000	8.10	10,200
	CA*F3131*6C*+MBR0800**,-1+TXV		18,000	13,100	14.0	12.0	16,700	13,000	18,000	8.50	10,800
	CA*F3131*6C*+TXV	G*V950453B**	18,000	13,100	15.0	12.5	16,700	13,000	18,000	8.10	10,200
	CA*F3131*6C*+TXV	A*V80704B**	18,000	13,100	15.0	12.5	16,700	13,000	18,000	8.10	10,200
	CA*F3131*6C*+TXV	A*V90453B**	18,000	13,100	15.0	12.5	16,700	13,000	18,000	8.10	10,200
	CA*F3131*6C*+TXV		19,000	13,900	14.0	12.0	17,600	13,700	18,000	8.50	10,400
	CHPF2430B6B*+EEP+TXV		18,400	13,400	14.0	12.0	17,000	13,300	18,000	8.50	10,800
CHPF2430B6B*+MBE1200**,-1A*+TXV		18,000	13,100	14.0	12.0	16,700	13,000	18,000	8.50	10,800	
CHPF2430B6B*+MBR0800**,-1A*+TXV		18,000	13,100	15.0	12.5	16,700	13,000	18,000	8.10	10,200	
CHPF2430B6B*+TXV	A*V80704B**	18,000	13,100	15.0	12.5	16,700	13,000	18,000	8.10	10,200	
CHPF2430B6B*+TXV	A*V90453B**	18,000	13,100	15.0	12.5	16,700	13,000	18,000	8.10	10,200	
CHPF2430B6C*+EEP+TXV		19,000	13,900	14.0	12.0	17,600	13,700	18,000	8.50	10,400	
CHPF2430B6C*+MBE1200**,-1B*+TXV		18,400	13,400	14.0	12.0	17,000	13,300	18,000	8.50	10,800	
CHPF2430B6C*+MBR0800**,-1+TXV		18,000	13,100	14.0	12.0	16,700	13,000	18,000	8.50	10,800	
CHPF2430B6C*+TXV	A*V90453B**	18,000	13,100	15.0	12.5	16,700	13,000	18,000	8.10	10,200	
CHPF2430B6C*+TXV	A*V80704B**	18,000	13,100	15.0	12.5	16,700	13,000	18,000	8.10	10,200	
CHPF3636B6B*+MBE1200**,-1A*+TXV		19,000	13,900	15.0	13.0	17,600	13,700	18,000	8.50	10,400	
CHPF3636B6C*+MBE1200**,-1B*+TXV		19,000	13,900	15.0	13.0	17,600	13,700	18,000	8.50	10,400	
CSCF3036N6B*+TXV	A*V80704B**	18,000	13,100	15.0	12.5	16,700	13,000	18,000	8.10	10,200	
CSCF3036N6B*+TXV	A*V90453B**	18,000	13,100	15.0	12.5	16,700	13,000	18,000	8.10	10,200	

<sup>1</sup> Seasonal Energy Efficiency Ratio: Certified per AHRI 210/240 @ 80°F/67°F/95°F  
<sup>2</sup> Energy Efficiency Ratio @ 80°F/67°F/95°F  
<sup>3</sup> TVA Rating: BTU/h @ 75°F/63°F - 95°F  
<sup>4</sup> HSPF = Heating Seasonal Performance Factor

- Notes:**
- Always check the S&R plate for electrical data on the unit being installed.
  - When matching the outdoor unit to the indoor unit, use the piston supplied with the outdoor unit or that specified on the piston kit chart supplied with the indoor unit.
  - EEP - Order from Service Dept. Part No. B13707-38 or new Solid State Board B13707-35S. Part No. B13707-38 is not interchangeable with B13707-35S. The Goodman Gas Furnace contains the EEP cooling time delay

# AHRI PERFORMANCE RATINGS (CONT.)

Outdoor Unit	Indoor Units		Cooling Capacity (BTU/h)			Heating Capacity (BTU/h)			AHRI #		
	Coil & Blower Units	Furnace	Total	Sens.	SEER <sup>1</sup>	EER <sup>2</sup>	Total	Sens.		High	HSPF <sup>4</sup>
ASZ14 0241A*	AEPF303616C*+TXV		24,000	18,000	15.0	13.0	22,200	17,800	22,000	8.50	12,000
	AEPF313716A*+TXV		24,000	18,000	15.0	13.0	22,200	17,800	22,000	8.50	12,000
	AR*F193116B*+TXV		24,000	18,000	14.0	12.0	22,200	17,800	24,000	8.50	14,000
	ASPF303616B*+TXV		24,000	18,000	15.0	13.0	22,200	17,800	22,000	8.50	12,000
	ASPF313716A*+TXV		24,000	18,000	15.0	13.0	22,200	17,800	22,000	8.50	12,000
	CA*F3636*6B*+EEP+TXV		24,000	18,000	14.0	12.5	22,200	17,800	24,000	8.50	14,000
	CA*F3636*6B*+MBE1200*-1+TXV		24,000	18,000	15.0	12.5	22,200	17,800	24,000	8.50	14,500
	CA*F3636*6B*+MBE1600*-1+TXV		24,000	18,000	15.0	13.0	22,200	17,800	22,000	8.50	12,000
	CA*F3636*6B*+MBR0800*-1+TXV		24,000	18,000	14.0	12.0	22,200	17,800	24,000	8.30	14,500
	CA*F3636*6B*+TXV	G*V950704C**	23,600	17,700	15.0	12.5	21,800	17,400	23,000	8.30	14,500
	CA*F3636*6B*+TXV	A*V80704B**	23,600	17,700	14.5	12.2	21,800	17,400	23,000	8.30	14,500
	CA*F3636*6B*+TXV	A*V90704C**	23,600	17,700	15.0	12.5	21,800	17,400	23,000	8.30	14,500
	CA*F3636*6B*+TXV	G*V950453B**	23,600	17,700	14.5	12.2	21,800	17,400	23,600	8.30	14,500
	CA*F3636*6B*+TXV	A*V90453B**	23,600	17,700	14.5	12.2	21,800	17,400	23,600	8.30	14,500
	CHPF3636B6B*+EEP+TXV		24,000	18,000	14.0	12.0	22,200	17,800	24,000	8.50	12,000
	CHPF3636B6B*+MBE1200*-1A*+TXV		24,000	18,000	15.0	12.0	22,200	17,800	24,000	8.50	14,500
CHPF3636B6B*+MBR0800*-1A*+TXV		24,000	18,000	14.0	12.0	22,200	17,800	24,000	8.50	14,500	
CHPF3636B6B*+TXV	A*V90453B**	24,000	18,000	14.5	12.2	22,200	17,800	24,000	8.30	14,500	
CHPF3636B6B*+TXV	A*V80704B**	24,000	18,000	14.5	12.2	22,200	17,800	24,000	8.30	14,500	
CHPF3636B6C*+EEP+TXV		24,000	18,000	14.0	12.0	22,200	17,800	24,000	8.50	12,000	
CHPF3636B6C*+MBE1200*-1B*+TXV		24,000	18,000	15.0	12.0	22,200	17,800	24,000	8.50	14,500	
CHPF3636B6C*+MBR0800*-1+TXV		24,000	18,000	14.0	12.0	22,200	17,800	24,000	8.50	14,500	
CHPF3636B6C*+TXV	A*V90453B**	24,000	18,000	14.5	12.2	22,200	17,800	24,000	8.30	14,500	
CHPF3636B6C*+TXV	A*V80704B**	24,000	18,000	14.5	12.2	22,200	17,800	24,000	8.30	14,500	
CSCF3036N6B*+TXV	A*V80704B**	24,000	18,000	14.5	12.2	22,200	17,800	24,000	8.30	14,500	
CSCF3036N6B*+TXV	A*V90453B**	24,000	18,000	14.5	12.2	22,200	17,800	24,000	8.30	14,500	
ASZ14 0301A*	AEPF303616C*+TXV		30,000	23,400	15.0	13.0	27,800	23,400	28,000	8.50	18,000
	AEPF313716A*+TXV		30,000	23,400	15.0	13.0	27,800	23,400	28,000	8.50	18,000
	AR*F193116B*+TXV		28,800	22,500	14.0	12.0	26,600	22,300	27,000	8.50	18,000
	ASPF303616B*+TXV		30,000	23,400	15.0	13.0	27,800	23,400	28,000	8.50	18,000
	ASPF313716A*+TXV		30,000	23,400	15.0	13.0	27,800	23,400	28,000	8.50	18,000
	CA*F3636*6B*+MBE1200*-1+TXV		28,800	22,500	15.0	13.0	26,600	22,300	28,800	9.00	18,000
	CA*F3636*6B*+TXV	A*V90704C**	28,800	22,500	15.0	12.5	26,600	22,300	28,800	8.50	18,000
	CA*F3636*6B*+TXV	A*V80704B**	28,800	22,500	15.0	12.5	26,600	22,300	28,800	8.50	18,000
CA*F3636*6B*+TXV	G*V950704C**	28,800	22,500	15.0	12.5	26,600	22,300	28,800	8.50	18,000	

See Notes on Page 20.

# AHRI PERFORMANCE RATINGS (CONT.)

Outdoor Unit	Indoor Units		Cooling Capacity (BTU/h)			TVA Ratings <sup>3</sup>			Heating Capacity (BTU/h)			AHRI #
	Coil & Blower Units	Furnace	Total	Sens.	SEER <sup>1</sup>	EER <sup>2</sup>	Total	Sens.	High	HSPF <sup>4</sup>	Low	
ASZ14 0301A* (cont.)	CA*F3636*6B**+TXV	A*V90453B**	28,800	22,500	15.0	12.5	26,600	22,300	28,800	9.00	18,000	1347337
	CA*F3743*6A**+EEP+TXV		28,400	22,200	14.0	12.0	26,300	22,100	28,800	8.50	18,000	1347341
	CA*F3743*6A**+MBE1600**-1+TXV		28,800	22,500	15.0	12.5	26,600	22,300	29,000	8.50	18,000	1346978
	CA*F3743*6A**+MBR1600**-1+TXV		28,800	22,500	14.0	12.0	26,600	22,300	29,000	8.50	18,000	1346979
	CA*F3743*6A**+TXV	A*V81155C**	28,800	22,500	14.5	12.2	26,600	22,300	29,000	8.50	18,000	1346981
	CA*F3743*6A**+TXV	A*V80905C**	28,800	22,500	14.5	12.2	26,600	22,300	29,000	8.50	18,000	1346980
	CHPF3636B6B**+MBE1200**-1A**+TXV		30,000	23,400	15.0	13.0	27,800	23,400	28,000	8.50	18,000	1347526
	CHPF3636B6C**+MBE1200**-1B**+TXV		30,000	23,400	15.0	13.0	27,800	23,400	28,000	8.50	18,000	3299367
	CHPF3642C6B**+EEP+TXV		28,800	22,500	14.0	12.0	26,600	22,300	29,000	9.00	18,000	1330186
	CHPF3642C6B**+MBE1600**-1A**+TXV		28,800	22,500	15.0	12.5	26,600	22,300	29,000	9.00	18,000	1330187
	CHPF3642C6B**+MBR1600**-1A**+TXV		28,800	22,500	14.0	12.0	26,600	22,300	29,000	9.00	18,000	1330188
	CHPF3642C6B**+TXV	A*V81155C**	28,800	22,500	14.5	12.2	26,600	22,300	29,000	8.50	18,000	1330190
	CHPF3642C6B**+TXV	A*V80905C**	28,800	22,500	14.5	12.2	26,600	22,300	29,000	8.50	18,000	1330189
	CHPF3642C6B**+TXV	A*V90704C**	28,800	22,500	14.5	12.2	26,600	22,300	29,000	8.50	18,000	1330191
	CHPF3642C6C**+EEP+TXV		28,800	22,500	14.0	12.0	26,600	22,300	29,000	9.00	18,000	3299368
	CHPF3642C6C**+MBE1200**-1B**+TXV		30,000	23,400	15.0	13.0	27,800	23,400	28,000	8.50	18,000	3299374
CHPF3642C6C**+MBE1600**-1B**+TXV		28,800	22,500	15.0	12.5	26,600	22,300	29,000	9.00	18,000	3299369	
CHPF3642C6C**+MBR1600**-1+TXV		28,800	22,500	14.0	12.0	26,600	22,300	29,000	9.00	18,000	3299370	
CHPF3642C6C**+TXV	A*V90704C**	28,800	22,500	14.5	12.2	26,600	22,300	29,000	8.50	18,000	3299373	
CHPF3642C6C**+TXV	A*V80905C**	28,800	22,500	14.5	12.2	26,600	22,300	29,000	8.50	18,000	3299371	
CHPF3642C6C**+TXV	A*V81155C**	28,800	22,500	14.5	12.2	26,600	22,300	29,000	8.50	18,000	3299372	
CSCF3642N6C**+TXV	A*V90704C**	28,800	22,500	14.5	12.2	26,600	22,300	29,000	8.50	18,000	1296576	
CSCF3642N6C**+TXV	A*V80905C**	28,800	22,500	14.5	12.2	26,600	22,300	29,000	8.50	18,000	1296574	
CSCF3642N6C**+TXV	A*V81155C**	28,800	22,500	14.5	12.2	26,600	22,300	29,000	8.50	18,000	1296575	
ASZ14 0361A*	AEPF313716A**+TXV		36,000	25,900	15.0	12.5	33,300	25,600	34,600	9.00	23,600	3323253
	AEPF426016C**+TXV		36,000	25,900	15.0	12.5	33,300	25,600	34,600	9.00	23,600	1492740
	AR*F374316B**+TXV		35,000	25,200	14.0	12.0	32,400	24,900	35,000	9.00	24,000	1492742
	ASPF313716A**+TXV		36,000	25,900	15.0	12.5	33,300	25,600	34,600	9.00	23,600	3323257
	ASPF426016B**+TXV		36,000	25,900	15.0	13.0	33,300	25,600	34,600	9.00	23,600	1492743
	CA*F3743*6A**+EEP+TXV		36,000	25,900	14.0	12.0	33,300	25,600	34,600	9.00	24,000	3012172
	CA*F4961*6A**+EEP+TXV		36,000	25,900	14.0	12.0	33,300	25,600	35,000	9.00	24,000	1347342
	CA*F4961*6A**+MBE1600**-1+TXV		35,000	25,200	14.5	12.2	32,400	24,900	35,000	9.00	24,000	1346982
CA*F4961*6A**+MBE2000**-1+TXV		35,000	25,200	15.0	13.0	32,400	24,900	35,000	9.00	24,000	1346983	
CA*F4961*6A**+MBR1600**-1+TXV		34,600	24,900	14.0	12.0	32,000	24,600	34,600	8.75	21,600	1346984	
CA*F4961*6A**+TXV	A*V90704C**	34,600	24,900	14.5	12.2	32,000	24,600	35,000	9.00	24,000	1346987	

See Notes on Page 20.

# AHRI PERFORMANCE RATINGS (CONT.)

Outdoor Unit	Indoor Units		Cooling Capacity (BTU/h)			Heating Capacity (BTU/h)			AHRI #	
	Coil & Blower Units	Furnace	Total	Sens.	SEER <sup>1</sup>	EER <sup>2</sup>	Total	Sens.		High
ASZ14 0361A* (cont.)	CA*F4961*6A*+TXV	A*V90905D**	34,600	24,900	15.0	12.5	32,000	24,600	35,000	24,000
	CA*F4961*6A*+TXV	G*V950704C**	34,600	24,900	14.5	12.2	32,000	24,600	35,000	24,000
	CA*F4961*6A*+TXV	A*V80905C**	34,600	24,900	14.5	12.2	32,000	24,600	34,600	24,000
	CA*F4961*6A*+TXV	A*V81155C**	34,600	24,900	14.5	12.2	32,000	24,600	34,600	24,000
	CA*F4961*6A*+TXV	A*V91155D**	34,600	24,900	15.0	13.0	32,000	24,600	35,000	24,000
	CHPF3743C6A*+EEP+TXV		36,000	25,900	14.0	12.0	33,300	25,600	34,600	24,000
	CHPF3743C6B*+EEP+TXV		36,000	25,900	14.0	12.0	33,300	25,600	34,600	24,000
	CHPF4860D6C*+EEP+TXV		35,000	25,200	14.0	12.0	32,400	24,900	35,000	24,000
	CHPF4860D6C*+MBE2000**-1A*+TXV		35,000	25,200	15.0	13.0	32,400	24,900	35,000	24,000
	CHPF4860D6C*+TXV	A*V90905D**	34,600	24,900	15.0	13.0	32,000	24,600	35,000	24,000
	CHPF4860D6C*+TXV	A*V91155D**	34,600	24,900	15.0	12.5	32,000	24,600	35,000	24,000
	CHPF4860D6D*+EEP+TXV		35,000	25,200	14.0	12.0	32,400	24,900	35,000	24,000
	CHPF4860D6D*+MBE2000**-1B*+TXV		35,000	25,200	15.0	13.0	32,400	24,900	35,000	24,000
	CHPF4860D6D*+TXV	A*V90905D**	34,600	24,900	15.0	13.0	32,000	24,600	35,000	24,000
ASZ14 0421A*	CA*F4961*6A*+TXV		41,000	31,600	15.0	13.0	37,900	31,100	40,000	27,400
	AR*F374316B*+TXV		40,000	30,800	14.0	12.0	37,000	30,300	41,000	25,000
	ASPF426016B*+TXV		41,000	31,600	15.0	13.0	37,900	31,100	40,000	27,400
	CA*F4961*6A*+EEP+TXV		41,000	31,600	14.0	12.0	37,900	31,100	42,000	27,400
	CA*F4961*6A*+MBE2000**-1+TXV		40,000	30,800	15.0	13.0	37,000	30,300	41,000	25,000
	CA*F4961*6A*+MBR2000**-1+TXV		40,000	30,800	14.0	12.0	37,000	30,300	41,000	25,000
	CA*F4961*6A*+TXV	A*V90905D**	40,000	30,800	15.0	12.5	37,000	30,300	41,000	25,000
	CA*F4961*6A*+TXV	A*V81155C**	40,000	30,800	15.0	12.5	37,000	30,300	41,000	25,000
	CA*F4961*6A*+TXV	A*V91155D**	40,000	30,800	15.0	13.0	37,000	30,300	41,000	25,000
	CA*F4961*6A*+TXV	A*V80905C**	40,000	30,800	15.0	12.5	37,000	30,300	41,000	25,000
	CHPF4860D6C*+EEP+TXV		40,000	30,800	14.0	12.0	37,000	30,300	41,000	27,400
	CHPF4860D6C*+MBE2000**-1A*+TXV		40,000	30,800	15.0	13.0	37,000	30,300	41,000	25,000
	CHPF4860D6C*+MBR2000**-1A*+TXV		40,000	30,800	14.0	12.0	37,000	30,300	41,000	27,400
	CHPF4860D6C*+TXV	A*V91155D**	40,000	30,800	15.0	13.0	37,000	30,300	41,000	25,000
CHPF4860D6C*+TXV	A*V90905D**	40,000	30,800	15.0	12.5	37,000	30,300	41,000	25,000	
CHPF4860D6D*+EEP+TXV		40,000	30,800	14.0	12.0	37,000	30,300	41,000	27,400	
CHPF4860D6D*+MBE2000**-1B*+TXV		40,000	30,800	15.0	13.0	37,000	30,300	41,000	25,000	
CHPF4860D6D*+MBR2000**-1+TXV		40,000	30,800	14.0	12.0	37,000	30,300	41,000	27,400	
CHPF4860D6D*+TXV	A*V90905D**	40,000	30,800	15.0	12.5	37,000	30,300	41,000	25,000	
CHPF4860D6D*+TXV	A*V91155D**	40,000	30,800	15.0	13.0	37,000	30,300	41,000	25,000	
CSCF4860N6C*+TXV	A*V91155D**	40,000	30,800	15.0	12.5	37,000	30,300	41,000	25,000	
CSCF4860N6C*+TXV	A*V90905D**	40,000	30,800	15.0	12.5	37,000	30,300	41,000	25,000	

See Notes on Page 20.

# AHRI PERFORMANCE RATINGS (CONT.)

Outdoor Unit	Indoor Units		Cooling Capacity (BTU/h)			Heating Capacity (BTU/h)			AHRI #			
	Coil & Blower Units	Furnace	Total	Sens.	SEER <sup>1</sup>	EER <sup>2</sup>	Total	Sens.		High	HSPF4	Low
ASZ14 0481A*	AEPF426016C*+TXV		47,000	35,700	15.0	13.0	43,500	35,200	47,000	8.75	30,000	
	AR*F374316B*+TXV		47,000	35,700	14.0	12.0	43,500	35,200	47,000	8.50	30,000	
	AR*F486016B*+TXV		45,000	34,200	13.5	11.5	41,600	33,700	46,000	8.50	30,000	
	ASPF426016B*+TXV		47,000	35,700	15.0	13.0	43,500	35,200	47,000	8.75	30,000	
	CA*F4961*6A*+EEP+TXV		46,000	35,000	14.0	12.0	42,600	34,500	47,500	8.75	30,000	
	CA*F4961*6A*+MBE2000**,-1+TXV		46,000	35,000	15.0	13.0	42,600	34,500	46,000	9.00	30,000	
	CA*F4961*6A*+MBR2000**,-1+TXV		46,000	35,000	14.0	12.0	42,600	34,500	47,000	8.50	30,000	
	CA*F4961*6A*+TXV	A*V90905D**		46,000	35,000	14.5	12.0	42,600	34,500	47,000	8.50	30,000
	CA*F4961*6A*+TXV	A*V81155C**		46,000	35,000	14.5	12.0	42,600	34,500	47,000	8.50	30,000
	CA*F4961*6A*+TXV	A*V91155D**		46,000	35,000	14.5	12.0	42,600	34,500	47,000	8.50	30,000
	CA*F4961*6A*+TXV	A*V80905C**		46,000	35,000	14.5	12.0	42,600	34,500	47,000	8.50	30,000
	CHPF4860D6C*+EEP+TXV		47,000	35,700	14.0	12.0	43,500	35,200	46,000	9.00	30,000	
	CHPF4860D6C*+MBE2000**,-1B*+TXV		46,000	35,000	14.5	12.0	42,600	34,500	47,000	9.00	30,000	
	CHPF4860D6C*+MBR2000**,-1A*+TXV		46,000	35,000	14.5	12.0	42,600	34,500	47,000	8.50	30,000	
	CHPF4860D6C*+TXV	A*V91155D**		46,000	35,000	14.5	12.0	42,600	34,500	47,000	8.50	30,000
	CHPF4860D6D*+EEP+TXV		47,000	35,700	14.0	12.0	43,500	35,200	46,000	9.00	30,000	
	CHPF4860D6D*+MBE2000**,-1B*+TXV		46,000	35,000	14.5	12.0	42,600	34,500	47,000	9.00	30,000	
	CHPF4860D6D*+MBR2000**,-1+TXV		46,000	35,000	14.5	12.0	42,600	34,500	47,000	8.50	30,000	
	CHPF4860D6D*+TXV	A*V91155D**		46,000	35,000	14.5	12.0	42,600	34,500	47,000	8.50	30,000
CSCF4860N6C*+TXV		46,000	35,000	14.5	12.0	42,600	34,500	47,000	8.50	30,000		
CSCF4860N6C*+TXV		46,000	35,000	14.5	12.0	42,600	34,500	47,000	8.50	30,000		
ASZ14 0601A*	AEPF426016C*+TXV		57,000	42,200	14.5	12.0	52,700	41,600	59,000	8.75	39,000	
	AR*F374316B*+TXV		57,000	42,200	13.5	11.5	52,700	41,600	57,000	8.50	36,000	
	AR*F496116A*+TXV		57,000	42,200	14.0	12.2	52,700	41,600	57,000	8.50	33,000	
	ASPF426016B*+TXV		57,000	42,200	14.5	12.0	52,700	41,600	59,000	8.75	39,000	
	CA*F4961*6A*+EEP+TXV		57,000	42,200	14.0	12.0	52,700	41,600	58,000	9.00	39,000	
	CA*F4961*6A*+MBE2000**,-1+TXV		56,500	41,800	15.0	12.5	52,300	41,300	57,000	9.00	33,000	
	CA*F4961*6A*+MBR2000**,-1+TXV		56,500	41,800	14.0	12.0	52,300	41,300	57,000	8.50	33,000	
	CA*F4961*6A*+TXV	A*V90905D**	56,500	41,800	14.0	11.5	52,300	41,300	57,000	8.50	33,000	
	CA*F4961*6A*+TXV	A*V91155D**	56,500	41,800	14.0	11.5	52,300	41,300	57,000	8.50	33,000	
	CHPF4860D6C*+EEP+TXV		57,000	42,200	14.0	12.0	52,700	41,600	58,000	8.75	39,500	
	CHPF4860D6C*+MBE2000**,-1A*+TXV		56,500	41,800	15.0	12.0	52,300	41,300	57,000	8.50	33,000	
	CHPF4860D6C*+MBR2000**,-1A*+TXV		57,000	42,200	14.0	12.0	52,700	41,600	57,000	8.75	38,000	
	CHPF4860D6C*+TXV	A*V90905D**	56,500	41,800	14.0	11.5	52,300	41,300	57,000	8.50	33,000	
	CHPF4860D6C*+TXV	A*V91155D**	56,500	41,800	14.0	11.5	52,300	41,300	57,000	8.50	33,000	
	CHPF4860D6D*+EEP+TXV		57,000	42,200	14.0	12.0	52,700	41,600	58,000	8.75	39,500	
	CHPF4860D6D*+MBE2000**,-1B*+TXV		56,500	41,800	15.0	12.0	52,300	41,300	57,000	8.50	33,000	
	CHPF4860D6D*+MBR2000**,-1+TXV		57,000	42,200	14.0	12.0	52,700	41,600	57,000	8.75	38,000	
	CHPF4860D6D*+TXV	A*V90905D**	56,500	41,800	14.0	11.5	52,300	41,300	57,000	8.50	33,000	
	CHPF4860D6D*+TXV	A*V91155D**	56,500	41,800	14.0	11.5	52,300	41,300	57,000	8.50	33,000	
	CSCF4860N6C*+TXV		56,500	41,800	13.5	11.5	52,300	41,300	57,000	8.50	33,000	
	CSCF4860N6C*+TXV		56,500	41,800	13.5	11.5	52,300	41,300	57,000	8.50	33,000	
	CSCF4860N6C*+TXV	A*V90905D**	56,500	41,800	13.5	11.5	52,300	41,300	57,000	8.50	33,000	
	CSCF4860N6C*+TXV		56,500	41,800	13.5	11.5	52,300	41,300	57,000	8.50	33,000	

See Notes on Page 20.



**DIMENSIONS**

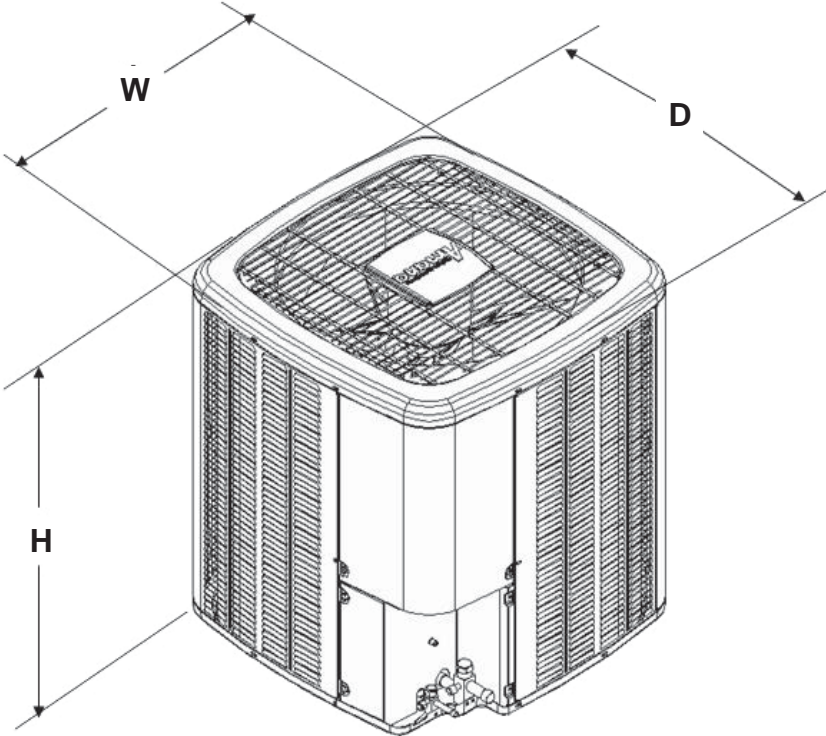

Model	Dimensions
ASZ140181A	29" x 29" x 34 <sup>1</sup> / <sub>4</sub> "
ASZ140241A	29" x 29" x 38 <sup>1</sup> / <sub>4</sub> "
ASZ140301A	29" x 29" x 38 <sup>1</sup> / <sub>4</sub> "
ASZ140361A	35 <sup>1</sup> / <sub>2</sub> " x 35 <sup>1</sup> / <sub>2</sub> " x 38 <sup>1</sup> / <sub>4</sub> "
ASZ140421A	35 <sup>1</sup> / <sub>2</sub> " x 35 <sup>1</sup> / <sub>2</sub> " x 38 <sup>1</sup> / <sub>4</sub> "
ASZ140481A	35 <sup>1</sup> / <sub>2</sub> " x 35 <sup>1</sup> / <sub>2</sub> " x 38 <sup>1</sup> / <sub>4</sub> "
ASZ140601A	35 <sup>1</sup> / <sub>2</sub> " x 35 <sup>1</sup> / <sub>2</sub> " x 38 <sup>1</sup> / <sub>4</sub> "



## ACCESSORIES

Model	Description	ASZ14 018	ASZ14 024	ASZ14 030	ASZ14 036	ASZ14 042	ASZ14 048	ASZ14 060
ABK-20	Anchor Bracket Kit <sup>▼</sup>	X	X	X	X	X	X	X
ASC01	Anti-Short Cycle Kit	X	X	X	X	X	X	X
CSR-U-1	Hard-start Kit	X	X	X	X			
CSR-U-2	Hard-start Kit				X	X	X	X
CSR-U-3	Hard-start Kit						X	X
FSK01A1	Freeze Protection Kit	X	X	X	X	X	X	X
OT18-60A2	Outdoor Thermostat	X	X	X	X	X	X	X
OT/EHR18-60	Emergency Heat Relay Kit	X	X	X	X	X	X	X
TX2N4 <sup>3</sup>	TXV Kit	X						
TX3N4 <sup>3</sup>	TXV Kit		X	X	X			
TX5N4 <sup>3</sup>	TXV Kit					X	X	X

<sup>▼</sup> Contains 20 brackets; four brackets needed to anchor unit to pad

<sup>1</sup> Installed on indoor coil

<sup>2</sup> Required for heat pump applications where ambient temperatures fall below 0 °F with 50% or higher relative humidity.

<sup>3</sup> Field-installed, non-bleed, expansion valve kit — Condensing units and heat pumps with reciprocating compressors require the use of start-assist components when used in conjunction with an indoor coil using a non-bleed thermal expansion valve refrigerant metering device.

**NOTES**

