

RESIDENTIAL COPPER TUBE BOILERS



TWO STAGE OPERATING CONTROL

OUTDOOR RESET WITH SENSOR

DOMESTIC HOT WATER PRIORITIZATION

GASKETLESS HEAT EXCHANGER

7 MODELS: 45,000 – 260,000 BTU/HR

BUILT-IN PERFORMANCE LOOP



Lochinvar.com



The Solution to Your Home Heating Boiler Needs

Hot water has been a Lochinvar tradition since 1919. With over 90 years of commercial sales, manufacturing and engineering expertise to rely upon, all Lochinvar products, including the Solution™ boiler, are designed to the highest standards of quality, safety, and reliability using the latest in technology.

The Right Investment

If you're looking for a heating system for your new home, replacing an old boiler, or thinking about converting from expensive electric heat, Lochinvar's Solution boiler is the right heating investment for you. You rarely think about heating your home, that is unless you can't get warm enough, or your monthly heating bill just surpassed your house payment. A reliable and efficient heating system is the key to keeping your family comfortable when the weather turns cold. That's why Lochinvar developed the Solution. This gas-fired boiler stands above any other boiler in its class in terms of comfort, quality, efficiency, flexibility and dependability.

Built For Dependability

Every Lochinvar boiler is made in the USA. Built to commercial grade standards, the Solution boiler is better designed and better built. And every Solution boiler is quality checked throughout the manufacturing process, giving you a boiler built for dependability. When you select Solution, you get home heating that is economical, reliable, flexible, safe and dependable and made here at home in the heartland of the USA. And we back it all up with our exclusive 20-year Limited Warranty.

Cost Savings High Efficiency

Often times old boilers operate as low as 50% efficiency. This means that 1/2 of your fuel dollars are wasted up the chimney. A Solution boiler, with an annual fuel utilization efficiency (AFUE) of up to 84%, can reduce your heating bills by over 30%. This means that the Solution boiler can actually pay for itself in just a few short years with the money the old system is wasting. If you are currently spending \$2,000 each year to heat your home with your old inefficient boiler, your fuel savings could be as much as \$800 per year by switching to the 84% efficient Solution boiler. Lochinvar's Solution boiler makes heating your home with gas a smart investment that you'll appreciate for years.

Other products available

KNIGHT AND CADET HEATING BOILERS

Need higher efficiency? KNIGHT Heating Boilers are available in sizes from 55,000 to 399,000 Btu/hr and rated up to 98% efficiency in low temperature applications. Cadet Heating Boilers are available in sizes from 40,000 to 120,000 Btu/hr and rated up to 94% AFUE efficiency.



Built-In Features

PVC or CPVC Vent Kit (optional)
Vent up to 25 feet out a sidewall or rooftop with inexpensive PVC/CPVC (CB 45-135).



Built-in Performance Loop
Ideal for replacing a cast iron boiler, the performance loop saves time and simplifies installation.



Two-Stage Gas Valve
The two-stage gas valve enables the boiler to start on low fire and continue on to high fire.

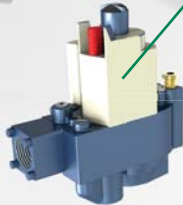

Lo/Hi/Lo Temperature Control
Since full boiler capacity is only needed 20% of the heating season the lo/hi/lo temperature control increases overall system efficiency by only turning the boiler on high fire when extra capacity is needed.

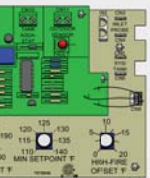

Domestic Hot Water Prioritization and Outdoor Temperature Reset
Allows the water temperature produced to vary with the demand of the outdoor conditions and provides domestic hot water production when paired with an indirect storage tank.

Ignition Control Module
Controls ignition and includes self diagnostic indicator lights.



Stainless Steel Burners
Ensure long life without rusting.



Intermittent Spark Ignition
The system safely shuts down on loss of pilot flame in less than one second.



Terminal Strips
Auxiliary power contacts for remote control of louvers and fans; or remote control of single stage or two stage firing.



Combustible Floor Base
Design certified for combustible floor installations. (Do not install directly on carpeting.)

Unique Heat Exchanger Design
You will enjoy years of reliable performance because the Solution is constructed with cast iron headers and a gasketless copper-tube heat exchanger. The combination of a copper heat exchanger with cast iron headers has the unique ability to absorb and transfer heat quickly and efficiently while providing unmatched durability.



Installation Flexibility

Lochinvar designed the Solution to make installations a snap in any home with all piping and venting connections made conveniently from the top of the unit. The Solution is also pre-piped with a pumped performance loop for easy hookup. Lightweight and compact, the Solution's flexibility allows the contractor to spend less time installing your new boiler, which results in savings to you.

SOLUTION BOILER DIMENSIONS AND SPECIFICATIONS

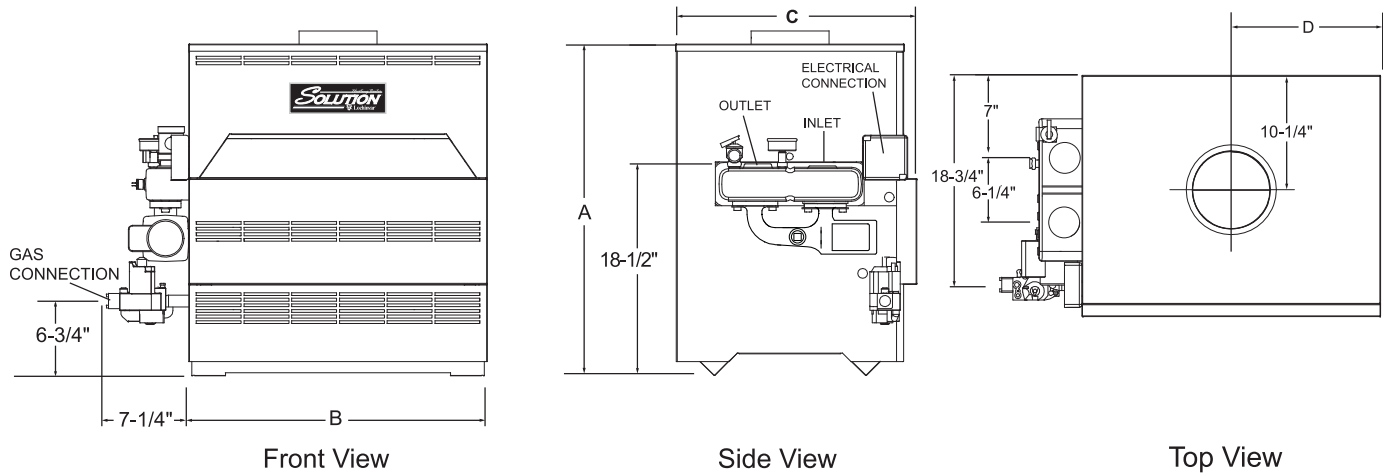

Model Number	Input MBH	AFUE %	Heating Net AHRI		A	B	C	D	Gas Conn.	Vent Size	Shipping Weight
			Capacity MBH	Rating MBH							
CBN045	45	84.0	37	32	29-1/2"	11-1/2"	21-1/2"	5-3/4"	1/2"	4"	145
CBN075	75	84.0	62	54	29-1/2"	15-1/2"	21-1/2"	7-3/4"	1/2"	5"	155
CBN090	90	84.0	75	65	29-1/2"	15-1/2"	21-1/2"	7-3/4"	1/2"	5"	155
CBN135	135	84.0	112	97	29-1/2"	19-1/2"	21-1/2"	9-3/4"	1/2"	6"	175
CBN180	180	84.0	149	130	29-1/2"	23-1/2"	21-1/2"	11-3/4"	3/4"	7"	195
CBN215	215	84.0	178	155	29-1/2"	26-1/2"	21-1/2"	13-1/4"	3/4"	7"	220
CBN260	260	84.0	216	188	29-1/2"	29-1/2"	21-1/2"	14-3/4"	3/4"	8"	225

Notes: Change 'N' to 'L' to denote L.P. gas models
Net ratings based on piping and pick-up allowance of 1.15

Electrical Requirements: 120 VAC / 2 AMP
Approved for indoor installation only

Water connections are 1-1/2" NPT
Performance data based on manufacturer test results.

STANDARD FEATURES

- ASME Copper Finned Tube Heat Exchanger
- Gasketless Heat Exchanger Design
- Built-In Performance Loop
- Vertical Water Connections
- 24 Volt Control System
- Self Diagnostic Ignition Control
- Terminal Strip
- Intermittent Electronic Ignition
- Two Stage Solid State Temperature Control
- Outdoor Reset with Outdoor Sensor
- Domestic Hot Water Prioritization
- Two Stage Gas Valve w/ Built In Manual Shut-Off
- 160 PSI Working Pressure
- Pump Relay
- Automatic Reset High Limit
- ASME Pressure Relief Valve
- Temperature & Pressure Gauge
- Automatic Vent Damper
- Built-In Draft Diverter
- Stainless Steel Burners
- Loch-Heat Ceramic Tile Combustion Chamber
- CSA Design Certified for Installation on Combustible Floors
- CSA Design Certified for Alcove Installation
- 20 Year Limited Warranty on the Heat Exchanger (see warranty for details)
- 2 Year Parts Warranty

OPTIONAL EQUIPMENT

- Adjustable High Limit w/ Manual Reset
- Flow Switch
- Low Water Cut-Off
- Stack Frame
- Pump Delay w/ Freeze Protection
- MP2 Sequencer
- PVC/CPVC Venting Kit (CB 45-135)
- O2 Barrier Waterways

FIRING CONTROL SYSTEMS

- M9 Two Stage, Intermittant Spark Ignition (Standard)
- M7 California Code (CB 215-260 only)

FOR EASE IN ORDERING BY MODEL NUMBER

CB	N	045	M9
MODEL	NAT GAS	Btu/Hr INPUT	FIRING CONTROLS

This model is a 45,000 Btu/hr, natural gas Solution boiler. It has M9 firing controls



Lochinvar, LLC
300 Maddox Simpson Parkway
Lebanon, Tennessee 37090
P: 615-889-8900 / F: 615-547-1000
www.Lochinvar.com

