

The RGB-25D recess box is for the Rinnai R/C85PLUS (REU-V2532WD/WCD) models.

1. Determine a suitable location meeting the installation clearances shown in Figure 1 below.

Local building codes may restrict the clearances shown below. If you are unsure if the clearances are acceptable in your area, consult with local building officials to verify prior to proceeding with installation.

Clearance to gas meter and electric meter shall be in accordance with local codes and the requirements of the gas supplier or electric supplier.

**Note:** The clearance to combustibles of the water heater/recess box assembly are zero inches to all surfaces of the recess box. A 24" clearance to combustibles and non-combustibles must be maintained from the front of the unit for servicing.

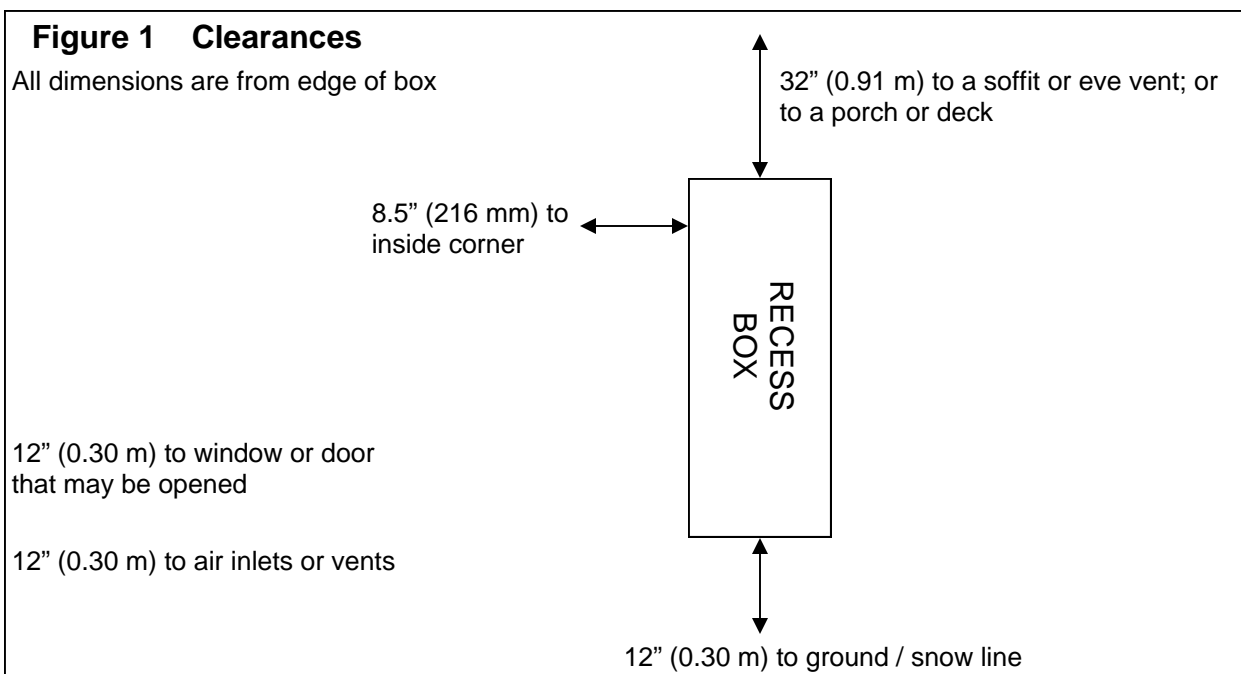

2. Prepare a rough opening with the following dimensions:

Height: 40-1/2" (1029 mm)	Width: 14-3/4" (375 mm)	Depth: 9-1/2" (241 mm)
---------------------------	-------------------------	------------------------

**Note:** The rough opening should be prepared, flashed and sealed to prevent moisture from entering the structure.

Apply a 3/8" bead of sealant along the back of the box flange. (Figure 2)

Insert the recess box into the rough opening. Secure the recess box to the building structure by drilling holes in the insides of the box and attaching with suitable screws.

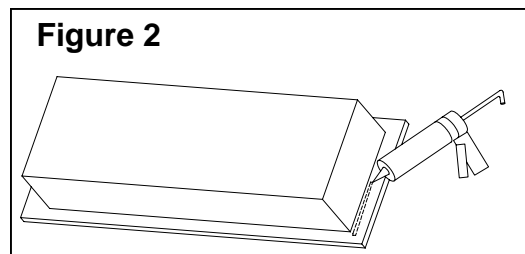

3. Position the rubber grommets (included) into the utility holes located at the bottom of the box. (Figure 3)

An additional hole must be drilled for the electrical service for the water heater. Locate this hole in a convenient location.

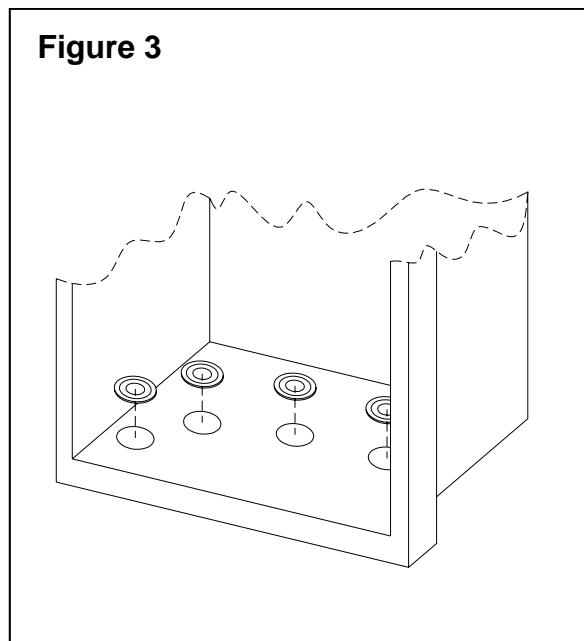

4. **IMPORTANT:** Copy the water heater serial number and model number from the data plate located on the left hand side of the appliance onto the sticker which is on the inside of the recess box cover. You will need to know this information for any future warranty or service work.

Model Number: \_\_\_\_\_

Serial Number: \_\_\_\_\_

Gas Type: \_\_\_\_\_

5. The water heater can now be mounted into the box.
  - a. Attach the top mounting brackets to the water heater as shown in Figure 4.
  - b. Lift the water heater into the recess box and align the screw mounted on the internal bracket with the keyhole on the top mounting bracket and tighten the screw.
  - c. Position the water heater such that the water heater bottom bracket holes are aligned with the recess box mounting studs and secure with the nuts provided.
  - d. Securely tighten the top mounting bracket screw to the recess box bracket.

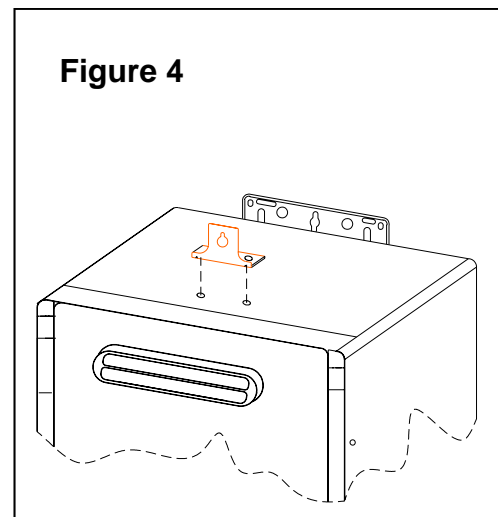

6. Connect gas, water and electric service to the water heater. Note: A waterproof electrical outlet can be fitted inside the enclosure.
7. **IMPORTANT:** You MUST use silicone sealant to seal around the pipes and openings cut into the recess box, along the seams of the top and bottom panels of the recess box, and between the recess box flange and the building structure to ensure that no water or gas can enter the wall cavity.
8. On completion of work, check for gas and water leaks.