

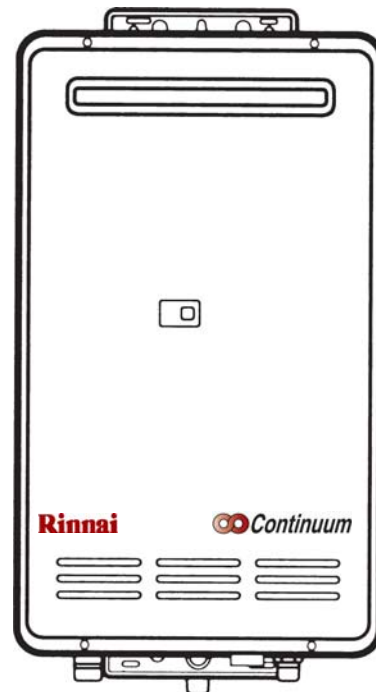

How to use your New Continuous Flow Water Heater

Model 2424 (*outdoor unit*)



Rinnai

WARNING: If the information in these instructions is not followed exactly, a fire or explosion may result causing property damage, personal injury or death.

-Do not store or use gasoline or other flammable vapors and liquids in the vicinity of this or any other appliance.

-WHAT TO DO IF YOU SMELL GAS

- * Do not try to light any appliance.
- * Do not touch any electrical switch; do not use any phone in your building
- * Immediately call your gas supplier from a neighbor's phone. Follow the gas supplier's instructions.
- * If you cannot reach your gas supplier, call the fire department.

- Installation and service must be performed by a qualified installer, service agency or the gas supplier.



S P E C I F I C A T I O N S

Type of appliance	Temperature controlled continuous flow gas hot water system
Operation	With / without remote controls, mounted in kitchen, bathroom, etc.
Exhaust system	Direct Vent - Forced combustion
Rinnai model number	REU-2424W-US
Maximum/Minimum gas rate (Input BTU's)	180,000 BTU's - 19,000 BTU's
Hot water capacity (50°F rise)	0.6 to 6.5 GPM
Setpoint Temperature (without remote)	120°F
Temperature range with remote Keypads connected	MC controller : 96 - 140°F BC and BSC controller : 96 - 120°F
Approved gas type	Natural or Propane - Ensure unit matches gas type it's being installed on.
Installation	Outdoor Only
Dimensions	Height 23 3/4" Width 13 3/4" Depth 6 3/4"
Weight	44 Lbs.
Efficiency rating	82%
Noise level	49 dB (A)
Connections	Gas supply 3/4" MNPT Cold water inlet 3/4" MNPT Hot water outlet 3/4" MNPT
Ignition system	Direct electronic ignition
Electrical consumption	Normal 55 watts Standby 8 watts Anti-frost protection 90 watts
Water temperature control	Simulation feedforward and feedback.
Water flow control	Water flow sensor and automatic electro-mechanical water flow control device
Minimum water supply pressure	40 PSI (Rinnai recommends 60-80 PSI for maximum performance)
Maximum water supply pressure	150 PSI



S P E C I F I C A T I O N S

Safety devices	Appliance - AC 120 Volts - 60Hz. Remote control DC 12 Volts (Digital)	
	Flame failure - Flame rod	
	Boiling protection - 203°F	
	Remaining flame (OHS) 194°F bi-metal switch	
	Thermal fuse 279°F	
	Automatic frost protection - Bi metal sensor & anti-frost heaters	
	Combustion fan rpm check - Integrated circuit	
	Over current - Glass fuse (3 amp)	
	If remote fails or becomes disconnected unit defaults to 100°F with water flowing, this is an anti-scald feature.	
Remote control	MC-45-3 US	Main control Kitchen / Laundry
	BC-45-3 US	Bathroom control
	BSC-45-3 US	Second bathroom control
Remote control cable	Non-polarized two core cable	
Clearances from combustibles	Top of heater	12"
	Front of heater	24"
	Sides of heater	6"
	Back of heater	0"
	Ground	12"
	Below eaves, porches, overhangs = 36"	
Minimum and Maximum gas supply pressure	Natural Gas : *Minimum 6" W. C. (NAT.) **Maximum 10.5" W. C.	Propane Gas: *Minimum 10" W. C. (LPG) **Maximum 14" W. C.
	Natural Gas 5.3" W. C. high fire	0.43" W. C. low fire
Manifold Gas Pressure	LPG: 8.7" W. C. high fire	0.59" W. C. low fire
	Residential: Ten years heat exchanger / five years parts (see unit's warranty for details) Commercial or Space Heating: (No Warranty - Use 2424WC Water Heater)	

*Minimum input pressure is for the purpose of input adjustments.
**Do not exceed maximum pressure.



WARRANTY

Rinnai warrants the Continuum continuous Hot Water Heater Model 2424W, including any parts and components thereof, to be free from any defects in materials and workmanship for the period specified below, subject to the terms specified in this warranty. This warranty gives you specific legal rights and you may also have other rights which vary from state to state.

This Warranty shall apply to the Continuum 2424W Continuous Hot Water Heater as follows:

CONDITION AND EXCEPTIONS

Table with 4 columns: Item, Type of Failure Covered, Domestic Use Period of Coverage, Commercial or Space Heat Period of Coverage. Rows include Heat Exchanger and All other parts and components.

In the event of a malfunction, operational difficulty or failure of the product, or any part or any component thereof, during the warranty term, resulting from defects in materials or workmanship, Rinnai will remedy the malfunction, operational difficulty, or failure without charge to the owner of the water heater. The remedy will consist of repair or replacement of the product at the option of Rinnai.

Rinnai will only provide those remedies listed above. The owner shall be responsible for all other costs, including but not limited to shipping and delivery charges, labor associated with the removal and reinstallation of the product or its components, and any other incidental costs such as other materials or permits that may be required for installation.

This warranty DOES NOT cover any failures, operational difficulty or malfunction due to accident, abuse, misuse, alteration, Acts of God, misapplications, improper installation or improper maintenance or service, lime damage, or from any other cause other than defects in materials or workmanship. Warranty does not cover use as a pool or spa heater.

PROCEDURE FOR MAKING A CLAIM

In order to obtain the benefits of the warranty, contact your selling dealer or Rinnai at 800-621-9419 for the location of the servicing dealer nearest you.

Proof of Purchase is required to institute a claim under this warranty. This document does not constitute proof-of purchase.

LIMITATION ON IMPLIED WARRANTIES

Any implied warranties of merchantability and fitness applicable to the equipment arising under state law are limited in duration to the period of coverage provided by this limited warranty, unless the period provided by state law is less. Some States do not allow limitations on how long an implied warranty lasts, so the above limitation may not apply to you.

DISCLAIMERS

Rinnai is not liable for any special, indirect or consequential damages, such as water damage, loss of use, inconvenience, damage to person or property, whether arising in contract or tort.

Rinnai does not authorize any person or company to assume for it any other obligation or liability in connection with the sale, application, engineering, installation, use, removal, return or replacement of its product, and no such representations are binding on Rinnai.

Please DETACH the enclosed warranty registration card, fill it out, and drop it in the mail. Receipt of this completed card by Rinnai will constitute proof-of purchase for your Rinnai Continuum 2424W.



C O N T E N T S

Specifications..... 2,3

Warranty 4

Owner's Installation Information 6

Features of your new Continuum 7

Safety Issues..... 8,9

Basic Operation..... 10

About Hot Water 11

Scalds-First Aid 11

Remote Control Operation 12

Error Messages 13

Maintenance & Service Information..... 14,15

Trouble Shooting and Common Questions 16

Operating Instructions..... 17,18

Care & Lime Condition Warning..... 18



OWNER'S INSTALLATION INFORMATION

This product must be installed by a Rinnai certified installer. Failure to have the product installed by a Rinnai certified installer may result in a voiding of the product's warranty.

This appliance must be installed in accordance with local codes, or in the absence of local codes, the National Fuel Gas Code, ANSI Z223.1 and/or the CAN/CGA-B149, Installation Codes.

Install this product outdoors, DO NOT install indoors.

Do Not use this appliance if any part has been underwater. Immediately call a qualified service technician to inspect the appliance and to replace any part of the control system and any gas control which has been underwater.











Detailed instructions on the proper installation practices to follow for the installation of your new continuous hot water heater are included at the back of this manual.



For the Rinnai Certified Installer nearest you call:

1-800-621-9419.

FEATURES OF YOUR NEW CONTINUUM

-  The Continuum 2424 is one of the most advanced water heaters available. It supplies hot water continuously at the temperature preset in the unit or at the temperature set on the optional remote control(s). Remote controls are recommended for optimum performance.
-  The Continuum 2424 never runs out of hot water. While electricity, water and gas supplies are connected, hot water is available whenever the hot tap is open.
-  The gas burner lights automatically when the hot water tap is opened, and goes out when the tap is closed. Ignition is electronic, there is no pilot light. When the hot water tap is off, no gas is used. You save energy and money with the Continuum 2424.
-  The temperature of the outgoing hot water is constantly monitored by a built in sensor. If the temperature of the outgoing water rises to more than 6 degrees above the selected temperature (shown on the optional digital remote control) the gas burner will automatically go out. The gas burner will re-ignite once the outgoing hot water temperature falls below the selected temperature.
-  Built into the microprocessor of the Continuum 2424 is the ability to LIMIT THE MAXIMUM TEMPERATURE of the hot water supplied by the Continuum 2424. Without the connection of an optional remote control, the Continuum 2424 is preset to deliver 120 degree water.
-  With the optional remote the water temperature is adjustable from 96 to 140 with the main controller and from 96 to 120 with the bath controller. The water temperature can be preset at 108, 120, 130, or 140 by a certified Rinnai technician. If you require a temperature other than 120 or what the remotes will give you, ***please contact your Rinnai certified technician.***
-  Error messages are displayed on the optional remote controls, simplifying service calls.
-  The Continuum 2424 incorporates a device to prevent the temperature from varying when the water is off, then on again. It also incorporates a rapid response device for fast heating.
-  The sound (noise) level from the Continuum 2424 is very low.
-  The Continuum 2424 is a very compact power vented device. It saves valuable floor and wall space.

Always check water temperature by hand before entering the shower or bath. The temperature may have been changed.



The water temperature can only be adjusted between 96°F and 110°F when the hot water tap is open, and hot water is flowing.



Do not clean Remote Controls with solvents. Use a soft damp cloth.



Do not touch the cover or insert objects into the flue outlet of the Continuum 2424.

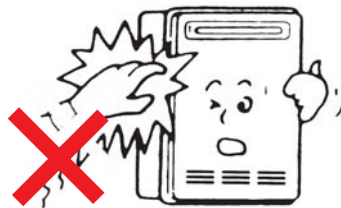

On cold days steam may be discharged from the flue outlet, this is normal with a high efficiency appliance and does not indicate a fault.

S A F E T Y I S S U E S

If the external Continuum 2424 is disconnected from the power supply and freezing conditions are expected, turn off water and gas, and drain all water from the appliance.

Water Off
↓
Gas Off
↓
Drain Water

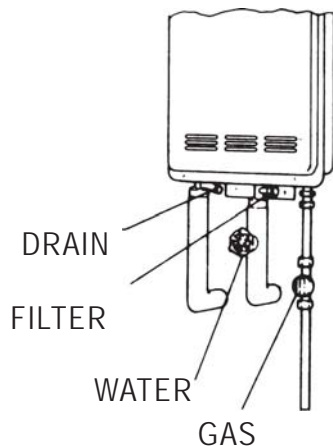

Keep flammable materials, trees, shrubs etc. away from the Continuum 2424



Do not spray water directly into the flue terminal.

If power and the automatic frost protection are connected, freezing will be prevented in conditions as cold as -30°F.

Depending on the weather conditions and the length of the pipe between the Continuum 2424 and the tap in use, there may be a variation between the temperatures displayed at the Remote Control and the temperature of the water at the tap.

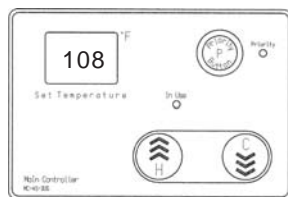
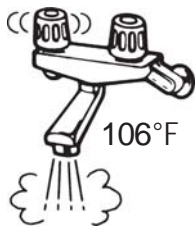

The Continuum 2424 controls the water temperature automatically. To do this it sometimes needs to change the water flow accordingly. The water flow from the hot water tap may vary after the selected temperature at the Remote Control is altered. The water flow may also vary from summer to winter, as incoming water temperatures differ.

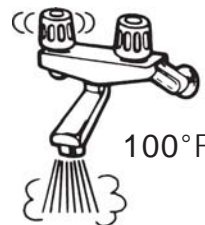

B A S I C O P E R A T I O N

1

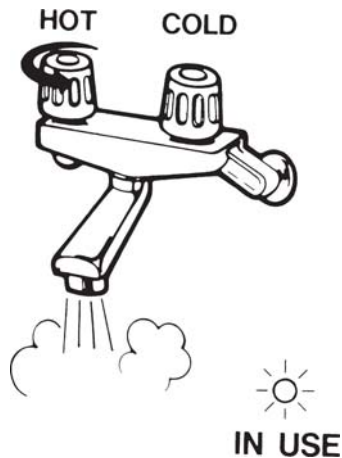

To operate the Continuum 2424 simply turn any hot water tap on. This will automatically light the burner providing hot water at the preset temperature. If the optional remote controls have been installed, the green IN USE indicator will glow on all remote controls.

2

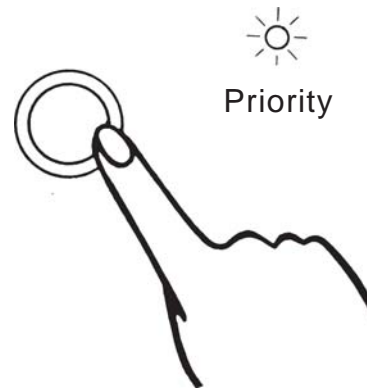

To take control of the Continuum 2424 all hot water taps must be closed. Press the “Priority button” on the control you want to set the temperature with and the yellow “Priority” indicator will glow on the Control which you have pressed the “Priority button” on. This indicates that the Continuum 2424 is ready to supply hot water at the set temperature as soon as a tap is opened.

3

Adjusting Temperature

The temperature can only be adjusted on the Remote Control where the Priority indicator is glowing, and the same temperature will be displayed on all Controls.

4

Simply press the  or  button until the required temperature is displayed on the Digital Monitor.

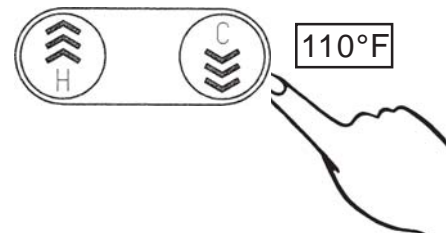

NOTE TEMPERATURE CANNOT BE ADJUSTED EXCEPT BETWEEN 96°F AND 110°F WHEN ANY HOT WATER TAP IS OPEN.



NOTE CHECK WATER TEMPERATURE BEFORE ENTERING SHOWER OR BATH. Always test the water temperature in bath before a child gets in. This is best done by the parent placing their elbow in the water.

A B O U T H O T W A T E R

Hot Water Is Dangerous, especially for the young and the elderly or the infirm. The Continuum 2424 allows you to precisely control the temperature of your hot water, ensuring safe hot water temperatures.



Water Temperatures over 125°F can cause severe burns instantly or death from scalds.

Hot Water can cause first degree burns with exposure for as little as:

- 3 seconds at 140 °F
- 20 seconds at 130 °F
- 8 minutes at 120 °F

Test the temperature of the water with your elbow before placing a child in the bath or shower.

Do not leave a child or an infirm person in the bath unsupervised.

S c a l d s - F i r s t A i d

- 1) **Remove clothing;** Remove all wet clothing, quickly. Wet clothing retains the heat.
- 2) **Apply cold water for 30 minutes;** Immediately submerge the burnt area in cold water for 30 minutes to reduce the heat in the skin, preventing deeper burning. *Never use butter, oils or ointment to cover the burn.* They may retain the heat.
- 3) **Keep the scalded person warm;** Place a blanket around the person.
- 4) **Seek Medical Advice;** Call your medical advice hotline and describe the scald, follow their directions.

REMOTE CONTROL OPERATION

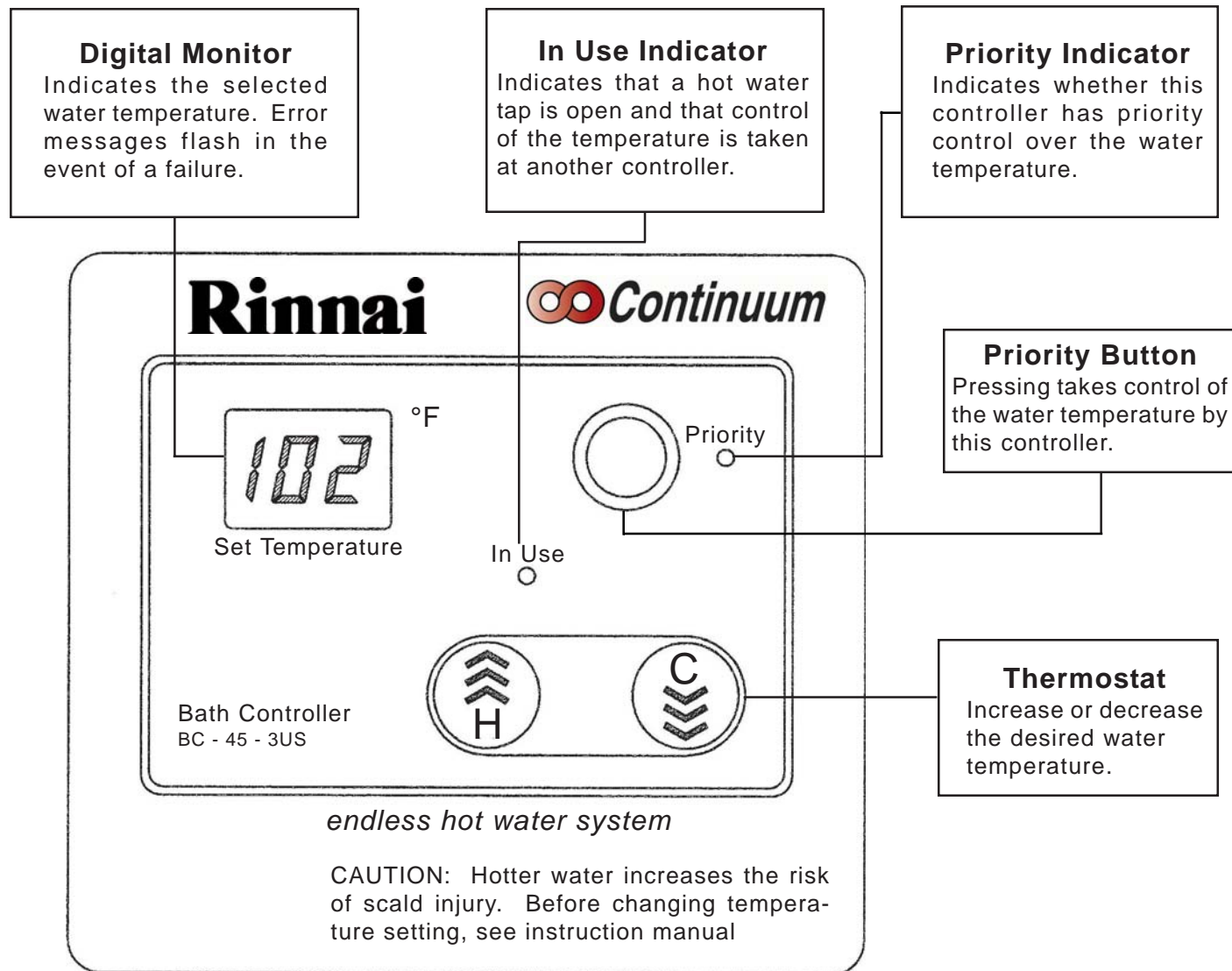

The Main Controller MC-45-3US is intended to be used in the kitchen, laundry room or utility area, the Bath Controller BC-45-3US and the Second Bath Controller BSC-45-3US are intended for installation in the bathroom.



E R R O R M E S S A G E S

The Continuum 2424 has the ability to check its own operation continuously. If a fault occurs, an Error Message will flash on the Digital Monitor of the Remote Controls. This assists with diagnosing the fault, and may enable you to overcome a problem without a service call. Please quote the code displayed when inquiring about service.

NOTE: Failure to remedy faults may result in severe burns, scalds, and/or death.

Code Displayed	Fault	Remedy
10	Air Supply or Exhaust Blockage	Check that nothing is blocking the air intake or exhaust.
11	No Ignition	Check that the gas is turned on at the water heater, gas meter or cylinder.
12	Flame Failure Earthing Failure	Check that the gas is turned on at the water heater and gas meter. Check for obstructions in flue outlet.
14	Remaining Flame Safety Device	Service Call
16	Over Temperature Warning	Service Call
31	Heat Exchanger Incoming Water Temperature Sensor Faulty	Service Call
32	Outgoing Water Temperature Sensor Faulty	Service Call
52	Mod. Solenoid Valve Answer Abnormal	Service Call
61	Combustion Fan Failure	Service Call
71	Solenoid Valve Driving Circuit Faulty	Service Call
72	Flame Sensing Device Faulty	Service Call
LC	Scale build-up in Heat Exchanger	Service Call



MAINTENANCE & SERVICE INFORMATION

Warning: Always turn off the electrical power supply, the manual gas valve and the manual water control valve whenever servicing the unit.



The Continuum 2424 should be checked by a Rinnai Certified Technician once a year. A Rinnai Certified Technician should perform any repairs that may be necessary.

The following items should be checked each inspection:

- 1) The area around the Continuum 2424 unit should be free from combustible materials such as cloth, vegetation and building materials. (see page 9)
- 2) Check burners for presence of foreign debris.
- 3) Remove and clean the inlet water filter.
- 4) Keep the appliance area clear and free from combustible materials, gasoline, and other flammable vapors and liquids.
- 5) Do not obstruct flow of combustion and ventilation air.

In the case of any fault or error message from the Continuum 2424, first turn all hot water taps off. Wait for 5 seconds. Turn the hot water tap back on. If this does not correct the fault or eliminate the error message from the remote control, press the priority button on and off twice to reset the system. If the error message still remains, call your Rinnai Authorized Service Representative or Rinnai at 800-621-9419.

Should overheating occur or the gas supply fail to shutoff, turn off the manual gas control valve to the appliance.



DO NOT ATTEMPT TO SERVICE YOUR Continuum 2424 YOURSELF.

Call a Rinnai Authorized Service Technician or call Rinnai at 800-621-9419.

MAINTENANCE & SERVICE INFORMATION

MAINTENANCE SUGGESTIONS

This water heater has been designed and constructed for a long performance life when installed and operated properly under normal conditions. Regular inspections, as outlined in this section, are strongly recommended as a means of keeping your heater operating efficiently.

1. Cleaning

The water heater must be cleaned annually. Keep the water heater clear of dust and debris especially in and around burner. Cleaning procedures for the Continuum are as follows:

- 1) Turn off and disconnect electrical power. Allow to cool for one hour.
- 2) Remove the Front Panel by removing screws. See parts breakdown on panels.
- 3) Use pressurized air to remove dust from around main burner.
- 4) Use soft dry cloth to wipe cabinet.

DO NOT DAMAGE OR DISTORT ANY PARTS OF HEATER.

DO NOT USE WET CLOTH OR SPRAY CLEANERS ON BURNER.

2. Visual check of main burner flames.

The burner must flame evenly over the entire surface when operating correctly. The flame must burn with a clear, blue, stable flame. See the parts breakdown of the burner for the location of view ports. Any and all parts removed for inspection or service must be replaced before operating the unit. The flame pattern should be as shown in the following Figures.

VISUAL CHECK

SATISFACTORY

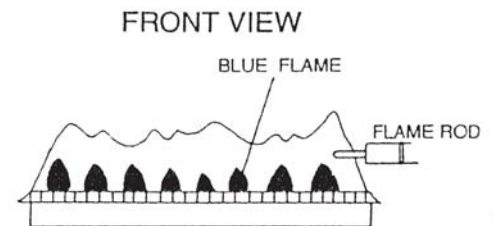

UNSATISFACTORY

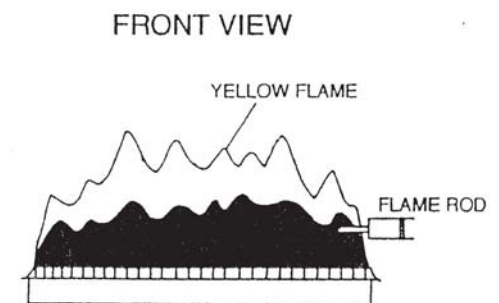

- * VENT MAINTENANCE
- * VENT SYSTEM

Must be checked annually for blockage or deterioration.

- * MAINTENANCE-ELECTRIC MOTORS

Motors are permanently lubricated and need no lubrication. Keep fan and motor free of dust and dirt, clean annually.



TROUBLE SHOOTING AND COMMON QUESTIONS

Q - *I don't have any hot water when I open the tap!*

A - Make sure there is gas and electricity to the Continuum 2424.
(the power is turned on and the gas is turned on)

Q - *When I was using the hot water, the water got cold!*

A - If you adjusted the flow from the tap to lessen it, you may have gone below the minimum flow required. The Continuum 2424 requires .6 GPM to operate. If you mix the water with a tap and attempt to get a temperature well below the temperature being controlled by the unit, it may drop the flow below .6 GPM. Decrease the temperature supplied by the Continuum 2424 at the remote control or increase your total flow.

Q - *White smoke comes out of the exhaust!*

A - During colder weather when the exhaust temperature is hotter than the air, the exhaust fumes condense producing white steam.

Q - *When I open a hot tap. I do not immediately get hot water!*

A - Hot water must travel through your plumbing from the Continuum 2424 to the faucet. This can take from 2 to 10 or more seconds depending upon your plumbing system.

Q - *After I turn off the hot water tap, the fan on the Continuum 2424 continues to run!*

A - The fan is designed to be on for 65 seconds after the flow of water stops. This is to ensure constant water temperatures during rapid starting and stopping, as well as exhausting any residual gas flue products from the unit.

FOR YOUR SAFETY READ BEFORE OPERATING

Warning: If you do not follow these instructions exactly, a fire or explosion may result causing property damage, personal injury or loss of life.

- A. This appliance is equipped with a direct ignition device which automatically lights the burner. Do not try to light the burner by hand.
- B. BEFORE OPERATING: Smell all around the appliance area for gas. Be sure to smell below the unit because some gas is heavier than air and will settle to the ground.
- WHAT TO DO IF YOU SMELL GAS**
 - Do not try to light any appliance.
 - Do not touch any electric switch, do not use any phone in your building.
 - Immediately call your gas supplier from a neighbor's phone. Follow the gas supplier's instructions.
- If you cannot reach your gas supplier, call the fire department.
- C. Use only your hand to operate remote control keypad. **Do not** use tools. Force or attempted repair may result in a fire or explosion. If the remote keypad doesn't work, call a qualified service technician.
- D. Do not use this appliance if any part has been under water. Immediately call a qualified service technician to inspect the appliance and to replace any part of the control system and any gas control which has been under water.

OPERATING INSTRUCTIONS

- 1) STOP! Read the safety information above before proceeding.
- 2) Set the thermostat to lowest setting.
- 3) Turn off all electric power to the appliance.
- 4) This appliance is equipped with a direct ignition device which automatically lights the burner. Do not try to light the burner by hand.
- 5) Turn the manual valve located at gas inlet of the appliance clockwise to "OFF". 

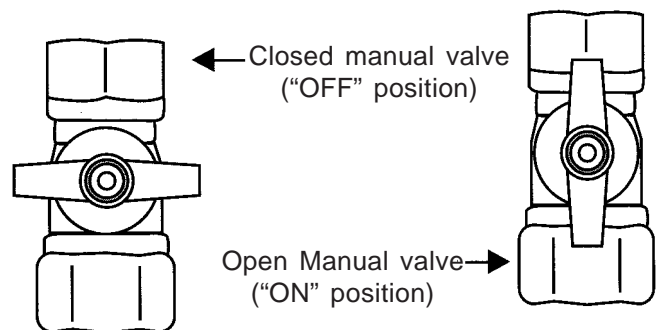

- 6) Wait (5) minutes to clear out any gas. If you then smell gas, STOP! Follow "B" in the safety information above on this label. If you don't smell gas, go to next step.



FOR YOUR SAFETY READ BEFORE OPERATING

- 7) Turn the manual valve located at the gas inlet of appliance counterclockwise to "ON". 
- 8) Turn on all electric power to the appliance.
- 9) Set thermostat to desired setting.
- 10) If the appliance will not operate, Follow the instructions "To Turn Off Gas To Appliance" and call your service technician or gas supplier.

To Turn Off Gas To Appliance

- 1) Set the thermostat to lowest setting.
- 2) Turn off all electric power to the appliance if service is to be performed.
- 3) Turn the manual valve at gas inlet of appliance clockwise  to "OFF"

CARE & LIME CONDITION WARNING

Care of Unit's Exterior:

Keep the exterior cabinet clean. Use a soft cloth and warm water when cleaning the cabinet. **Do Not** use volatile substances such as benzene and thinners, as they may ignite, or cause fading of the paint.

Lime Condition Warning Signal:

If you notice "LC" flashing on the remote key pad, this means the unit is beginning to lime up, and **MUST** be flushed. Contact a qualified Rinnai service technician to flush the appliance. Failure to flush the appliance when "LC" is flashing, will cause damage to the heat exchanger. Damage caused by lime build up is not covered by the unit's warranty.



Installer's Instructions

This section is for the Rinnai Certified Installer only. **If you are not certified you are not authorized to install this unit.** The warranty may be voided due to installation by a non-certified installer. For information on becoming a Rinnai Certified Installer, call

1-800-621-9419.

Contents of Installer's Manual

Warnings.....	20
Performance Data.....	21
Locating the Unit.....	22
Dimensions.....	22
Recommended Piping for Installation.....	23,24
Power Failure Freeze Protection.....	25
Gas Piping Sizing Charts.....	26
Gas Piping Notes.....	27
Water Piping Notes.....	28
Pressure Relief Valve.....	28
Electrical Connection Notes.....	29
Wiring Diagram.....	30,31
Lighting the Unit.....	32
Remote Controls.....	33,34
Testing.....	35
Diagnostic Points.....	36
Schematic Diagram.....	37
Exploded View.....	38-41
Parts List.....	42-46

Rinnai

www.rinnaiamerica.com

800-621-9419



INSTALLER'S INSTALLATION INSTRUCTIONS
-Warnings-

This manual must be followed exactly.

- 1) Read the safety issues completely before installing the Continuum 2424.
- 2) This water heater is suitable for water (potable) heating or space heating.
 - The piping connected to the Continuum 2424 must be approved for use in potable water systems.
 - Toxic chemicals such as those used for boiler water treatment are NOT to be introduced to the Continuum 2424.
 - The Continuum 2424, if it will be used as a potable water source, it must not be connected to a system that was previously used with a nonpotable water heating appliance.
- 3) The Continuum 2424 is not suitable for use as a pool or spa heater.
- 4) The dip switches on the computer board have been preset at the factory and should not be readjusted without the express knowledge and involvement of Rinnai.
- 5) ***Install the Continuum 2424 outdoors only.***
- 6) Maintain proper space around the unit for proper servicing and operation. Minimum clearances from combustible materials are listed below.

Top of Heater	12 inches
Back of Heater	0 inch
Front of Heater	24 inches
Sides of Heater	6 inches
Ground	12 inches

DO NOT install the Continuum 2424 under an overhang less than 3 feet from the top of the unit. The area under any overhang greater than 3 feet must be open on three sides.

- 7) Installer must install a Pressure relief valve. Pipe pressure relief discharge to a drain or outside environment (see page 27).

**INSTALLER'S INSTALLATION INSTRUCTIONS
CONTINUUM OUTLET FLOW DATA**

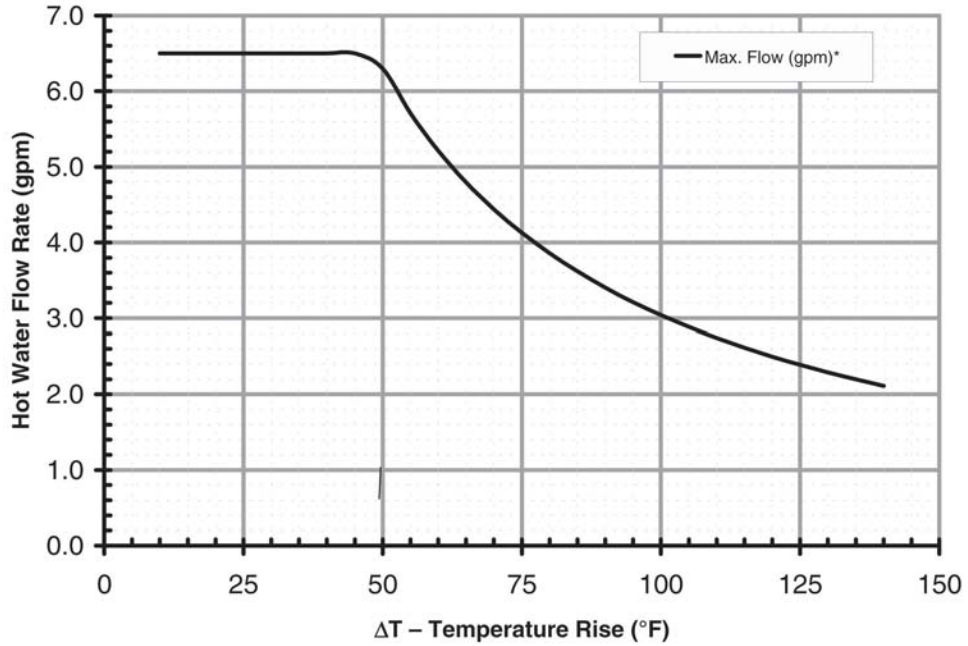

**INSTALLER'S INSTALLATION INSTRUCTIONS
CONTINUUM PRESSURE DROP CURVE**

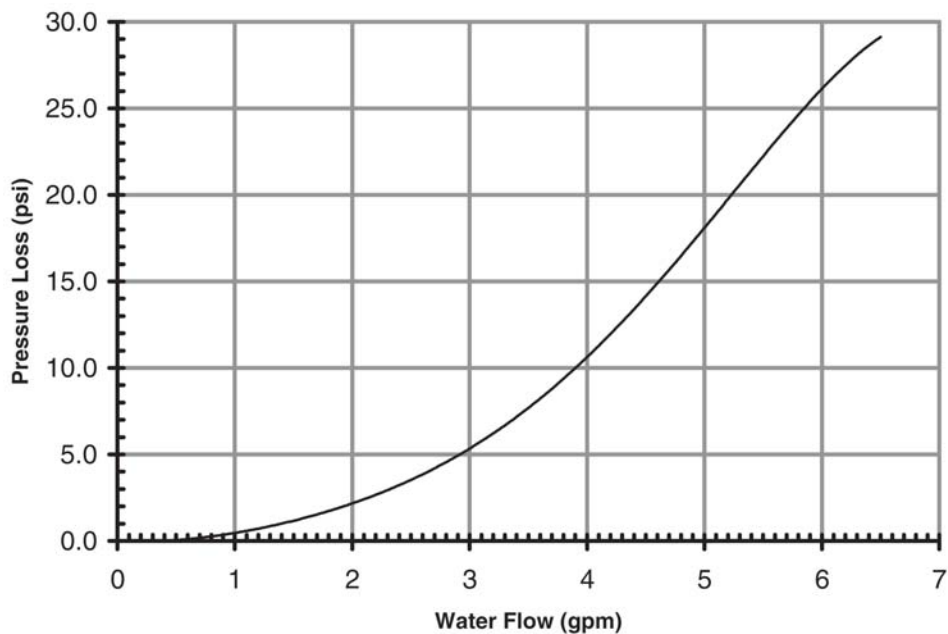

INSTALLER'S INSTALLATION INSTRUCTIONS
Locating the unit

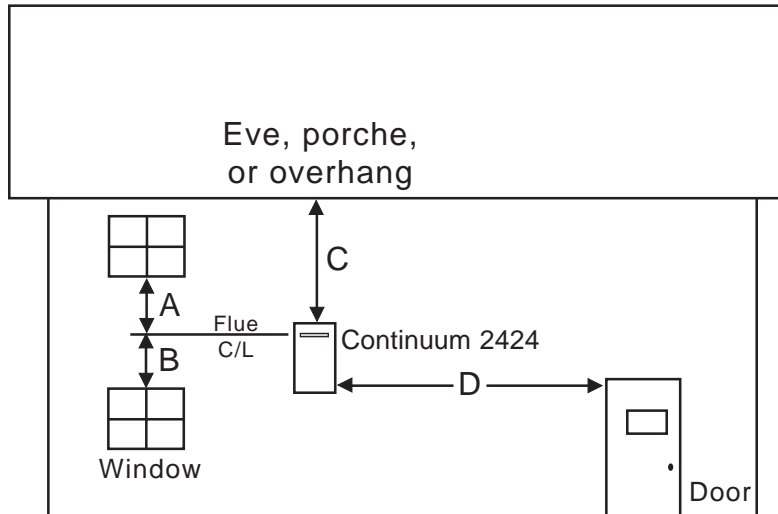

Vent termination clearances

	Minimum
A.....Vertically below an openable window.....	12"
B.....Vertically above an openable window, door, etc.....	12"
C.....Below eves, porches, overhangs.....	36"
D.....Horizontally from an openable window, door, etc.....	12"

INSTALLER'S INSTALLATION INSTRUCTIONS
Dimensions

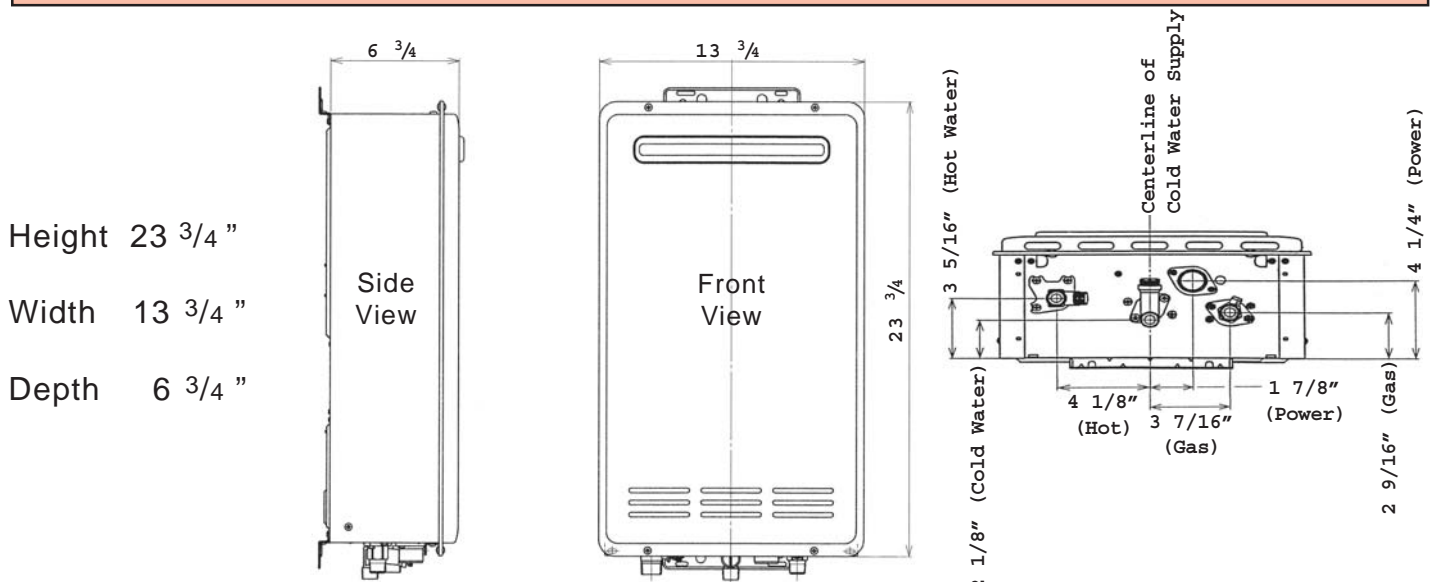

RECOMMENDED PIPING FOR INSTALLATION

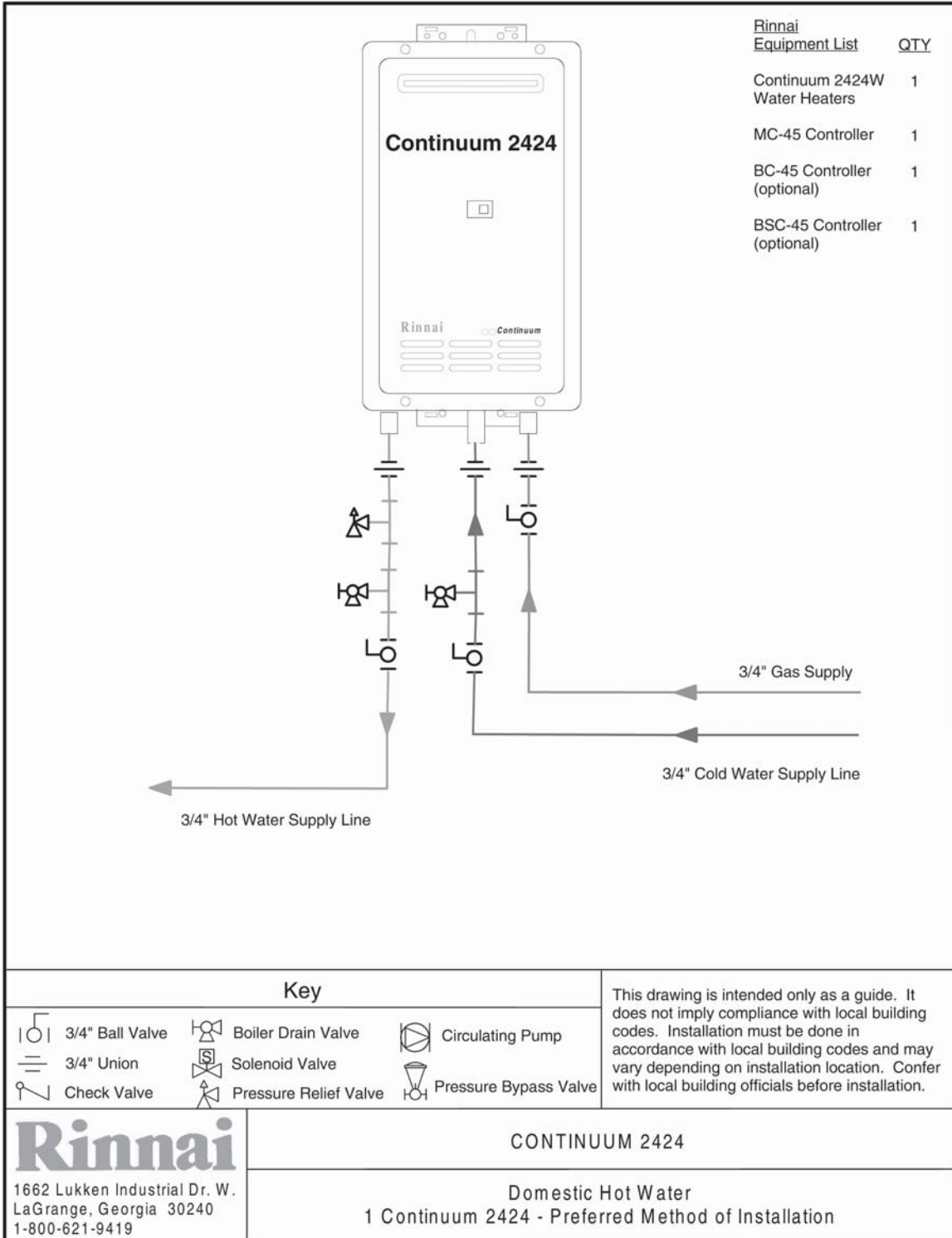

RECOMMENDED PIPING FOR INSTALLATION

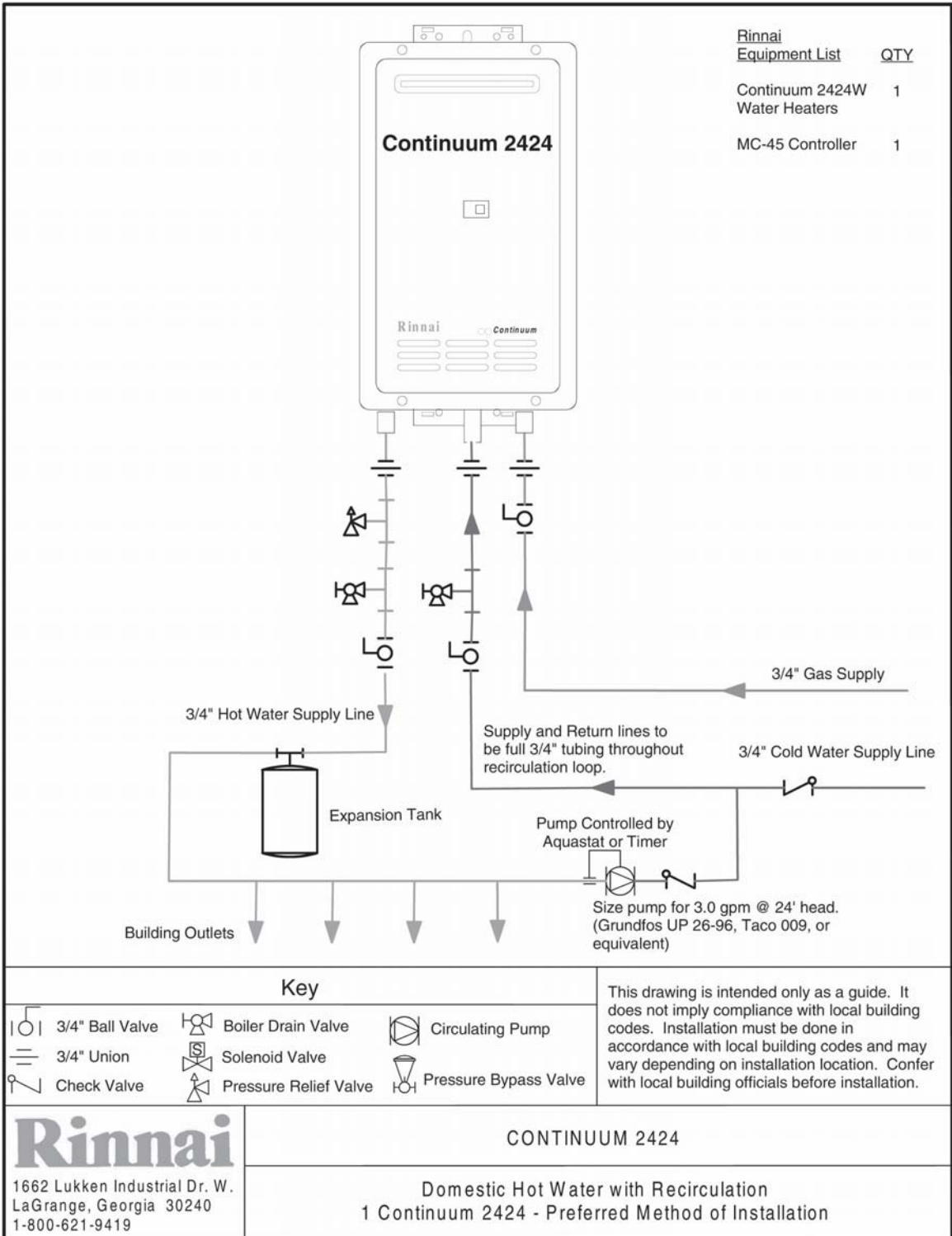

INSTALLER'S INSTALLATION INSTRUCTIONS OPTIONAL: Power Failure Freeze Protection

IMPORTANT!

With electrical power supplied to the Continuum 2424, it will not freeze in environments as cold as -30°F, when protected from direct wind exposure.

In the event of a power failure at temperatures below freezing, the Continuum 2424 should be drained of all water to prevent freezing damage.

The unit may be drained manually, or through the installation of the optional solenoid valves as shown.

The electrical connections for the two solenoids should be tied to the power switch for the Continuum 2424.

When the electrical power to the Continuum 2424 fails, the 3/4" solenoid closes, stopping flow into the heater and the 1/4" solenoid opens, allowing the unit and the associated piping to drain. Insure you run the drain for the solenoids to the outside environments to prevent discharging water inside the home causing water damage.

NOTE:

Heat trace and insulate ALL water pipe and fittings located outside home or building structure. (ALL water pipe and fittings shown above the dashed line in the drawing.)

NOTE:

ALL water lines shown with dashed lines, and all pipe and fittings shown below dashed black line, should be located inside home or building structure.

Vacuum breaker line should also be located inside home or structure.

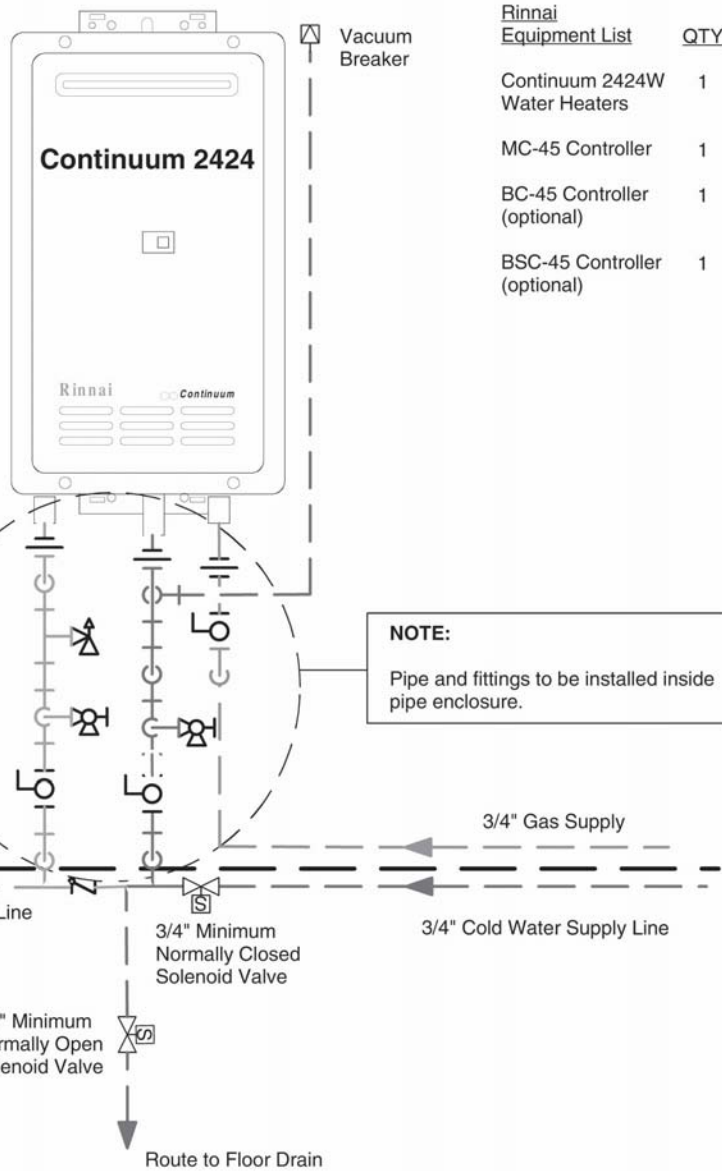

Rinnai Equipment List

Equipment List	QTY
Continuum 2424W Water Heaters	1
MC-45 Controller	1
BC-45 Controller (optional)	1
BSC-45 Controller (optional)	1

NOTE:

Pipe and fittings to be installed inside pipe enclosure.

Key

	3/4" Ball Valve		Boiler Drain Valve		Circulating Pump
	3/4" Union		Solenoid Valve		Pressure Bypass Valve
	Check Valve		Pressure Relief Valve		

This drawing is intended only as a guide. It does not imply compliance with local building codes. Installation must be done in accordance with local building codes and may vary depending on installation location. Confer with local building officials before installation.

Rinnai

1662 Lukken Industrial Dr. W.
LaGrange, Georgia 30240
1-800-621-9419

CONTINUUM 2424

Domestic Hot Water with Optional Pipe Cover
and Solenoid Valves to Drain Unit During Power Outage
1 Continuum 2424 - Preferred Method of Installation



INSTALLER'S INSTALLATION INSTRUCTIONS
Gas Pipe Sizing Chart

Capacity Table for Natural Gas
cubic feet / hour

(table assumes .3 inch pressure drop, specific gravity of .60)

Nominal Iron Pipe Size Inches	Length of Pipe in Feet													
	10	20	30	40	50	60	70	80	90	100	125	150	175	200
3/4	278	190	152	130	115	105	96	90	84	79	72	64	59	55
1	520	350	285	245	215	195	180	170	160	150	130	120	110	100
1-1/4	1050	730	590	500	440	400	370	350	320	305	275	250	225	210
1-1/2	1600	1100	890	760	670	610	560	530	490	460	410	380	350	320

After determining the length of pipe required select the pipe size that will supply the cubic feet per hour of gas required for the input rating of the Continuum 2424.

The formula for figuring the cubic feet per hour required is:

$$CFH = \frac{\text{Gas Input of Continuum 2424(BTU/HR)}}{\text{Heating Value of Gas(BTU/FT}^3\text{)}}$$

*Gas input requirement is on the water heater data plate

*The heating value of the gas can be obtained from the local Natural Gas Utility

Capacity Table for LP Gas

BTUH of undiluted liquified petroleum gases

(table assumes 11 inches of water column pressure at the inlet, .5 inch drop)

Nominal Iron Pipe Size Inches	Length of Pipe in Feet											
	10	20	30	40	50	60	70	80	90	100	125	150
1/2	275	189	152	129								
3/4	567	393	315	267	237	217	196	185	173	162	146	
1	1071	732	590	504	448	409	378	346	322	307	275	252
1-1/4	2205	1496	1212	1039	913	834	771	724	677	630	567	511



INSTALLER'S INSTALLATION INSTRUCTIONS

Gas Piping Notes

- 1) A manual gas control valve must be placed upon the gas inlet connection to the Continuum 2424 before it is connected to the gas line. A union can be used on the connection of the Continuum for the future servicing or disconnection of the unit.
- 2) Check the type of gas and the gas inlet pressure before connecting the Continuum 2424. If the Continuum 2424 is not of the gas type that the building is supplied with, DO NOT connect the water heater. Contact the dealer for the proper unit to match the gas type.
- 3) Minimum and Maximum Gas pressures are listed below:
* Minimum value is for input adjustment

Natural Gas: Minimum 7" WC
Maximum 10.5" WC

Propane Gas: Minimum 10" WC
Maximum 14" WC

WARNING: Conversion of this unit from natural gas to propane or propane to natural gas CANNOT be done in the field.

- 4) Always use approved connectors to connect the unit to the gas line. Always purge the gas line of any debris before connection to the water heater.
- 5) The Continuum 2424 must be leak tested before it is placed into operation.
- 6) After completion of gas pipe connections, all joints including the heater must be checked for gas-tightness by means of leak detector solution, soap and water, or an equivalent nonflammable solution, as applicable. **Caution:** Since some leak test solutions, including soap and water, may cause corrosion or stress cracking, the piping must be rinsed with water after testing, unless it has been determined that the leak solution is non-corrosive.
- 7) **The Continuum 2424 and its individual shut-off valve must be disconnected from the gas supply piping system when pressure testing of the gas supply piping system at test pressures equal to or greater than 1/2 psi.**
- 8) **The Continuum 2424 must be isolated from the gas supply piping system by closing it's individual manual shutoff valve during any pressure testing of the gas supply piping system at test pressures less than 1/2 psi.**
- 9) The Continuum 2424's Installation location must provide adequate Combustion and Ventilation airflow.



INSTALLER'S INSTALLATION INSTRUCTIONS

Water Piping Notes

- 1) A manual water control valve must be placed upon the water inlet connection to the Continuum 2424 before it is connected to the water line. Unions may be used on both the hot/cold water supply lines, for the future servicing or disconnection of the unit.
- 2) All soldering materials and piping must be compatible with potable water.
- 3) Purge the water line to remove from it all debris and air. Debris will damage the Continuum 2424.
- 4) There is a wire mesh strainer on the Continuum 2424's inlet to discourage the introduction of debris to the unit. It will need to be cleaned periodically.
DO NOT operate unit without filter in place.

WARNING: DO NOT reverse the inlet and outlet (cold and hot water) connections on the unit. This would cause the Continuum 2424 to operate dangerously or not at all.

INSTALLER'S INSTALLATION INSTRUCTIONS

Pressure Relief Valve

- 1) ANSI code calls for the addition of an approved pressure relief valve to all water heating systems.
- 2) The pressure relief valve must meet the following criteria: The relief valve must comply with the standard for Relief Valves and Automatic Gas Shutoff Devices for Hot Water Supply Systems ANSI Z21. 22. This relief valve must be rated at 150 PSI of pressure.
- 3) The relief valve should be added to the hot water outlet line per manufacturer's instructions. DO NOT place any other type valve or shut off device between the relief valve and the hot water heater.
- 4) The discharge from the pressure relief valve should be piped to the ground or into a drain system to prevent exposure or possible burn hazards to humans or other plant or animal life. Water discharged from the relief valve could cause severe burns instantly, scalds and/or death.
- 5) Do not plug the relief valve and do not install any reducing fittings or other restrictions in the relief line. The relief line should allow for complete drainage of the valve and the line.
- 6) Pressure relief valve must be manually operated once a year to check for correct operation.
- 7) Should overheating occur or the gas supply fail to shut off, turn off the manual gas valve on the Continuum 2424.

INSTALLER'S INSTALLATION INSTRUCTIONS Electrical Connection Notes

WARNING: The Continuum 2424 must be electrically grounded in accordance with local codes or in the absence of local codes with the most recent edition of the National Electrical Code, ANSI/NFPA 70. In Canada, all electrical wiring to the Continuum 2424 should be in accordance with local codes and the Canadian Electrical Code, CSA C22.1 Part1. Do not rely on the gas or water piping to ground the metal parts of the water heater.

CAUTION: Label all wires prior to disconnection when servicing controls. Wiring errors can cause improper and dangerous operation. Verify correct operation after servicing.

- 1 The Continuum 2424 requires 120VAC/60 HZ. Power from a properly grounded circuit, GFI.
- 2 An on/off switch must be provided and installed for the incoming 120VAC power.
- 3 Wire the Continuum 2424 exactly as shown in the wiring diagram on the next page and on the inside of the cover panel. The blue wire is the hot leg wire; the brown wire is the neutral wire.
- 4 A green screw is provided in the junction box for the grounding connection.

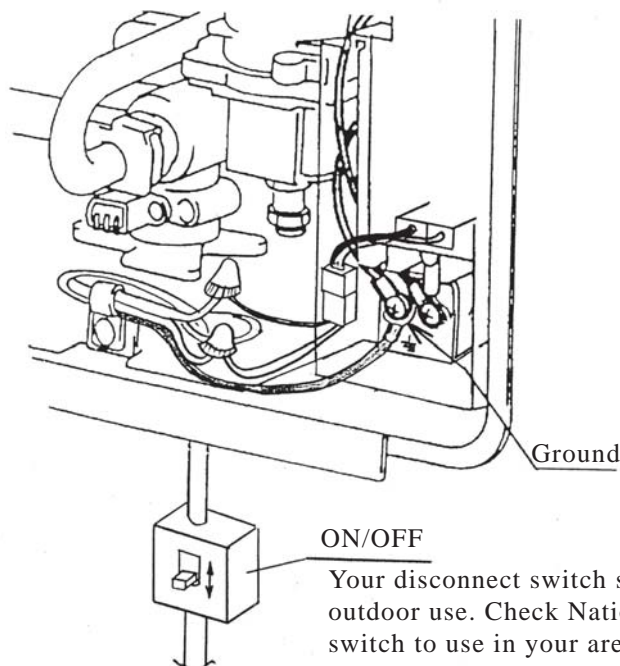

ON/OFF

Your disconnect switch should be a type that is suitable for outdoor use. Check National Electrical Codes for proper type switch to use in your area.

INSTALLER'S INSTALLATION INSTRUCTIONS

Wiring Diagram

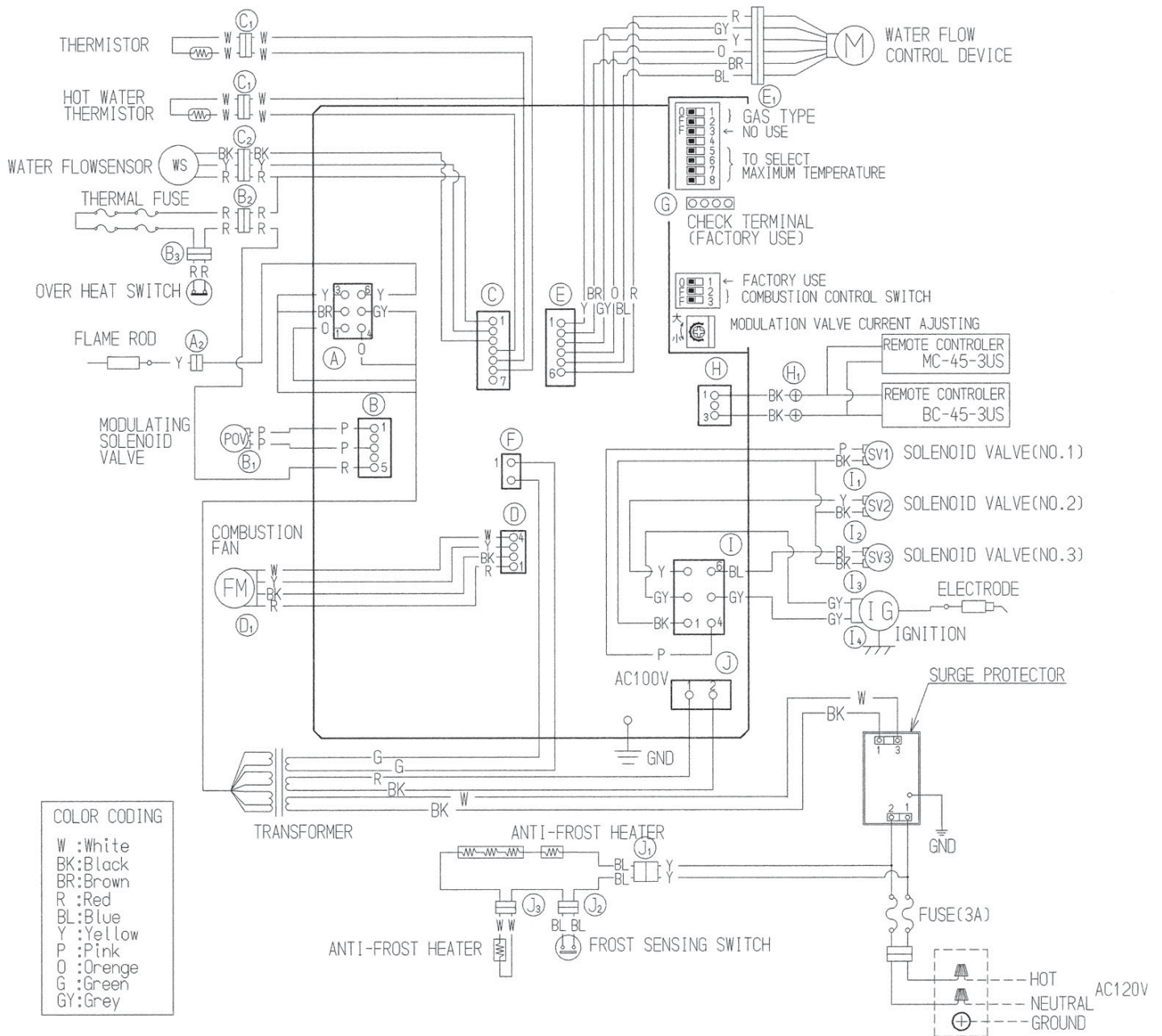

INSTALLER'S INSTALLATION INSTRUCTIONS
Wiring Diagram

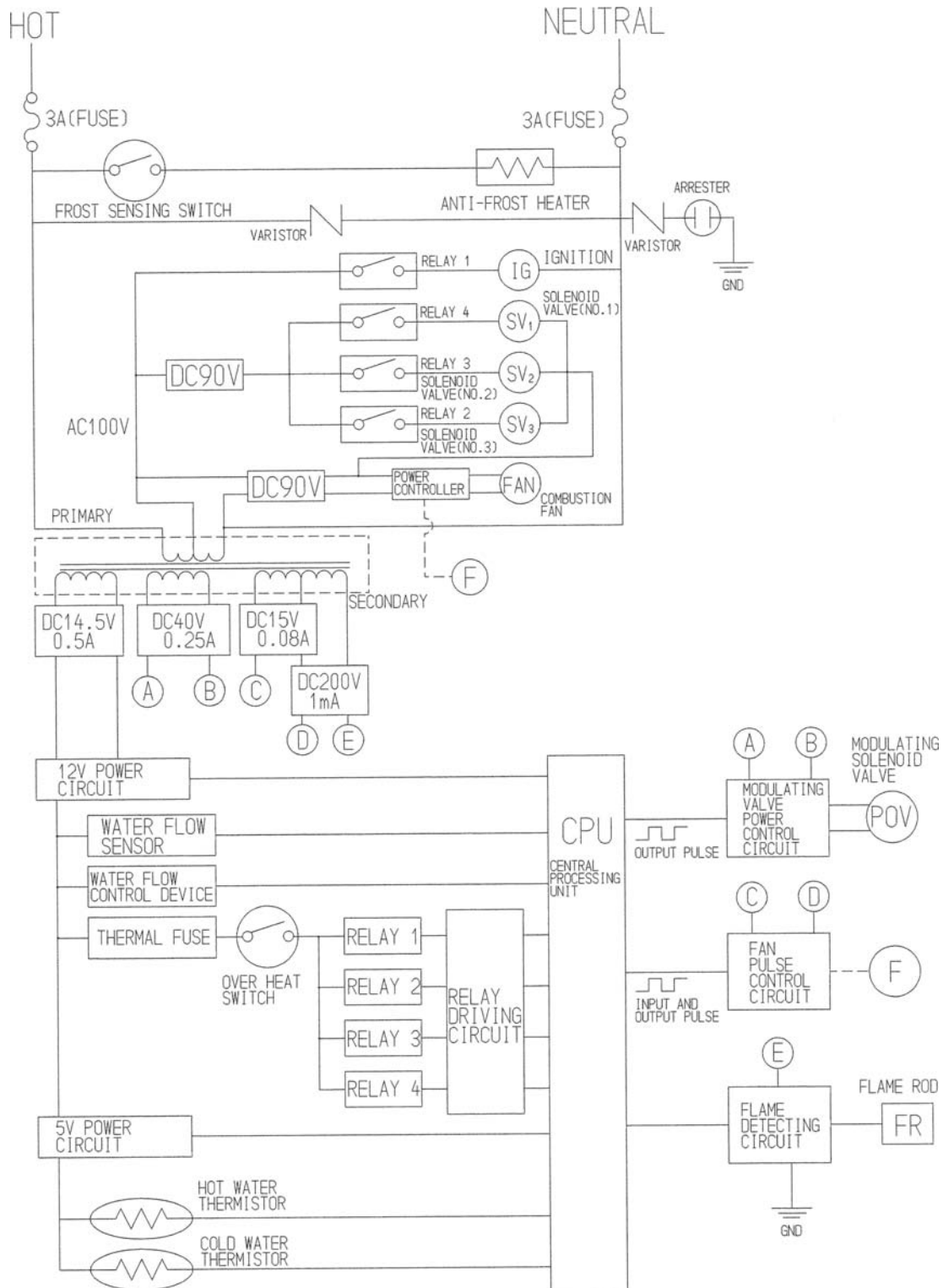



INSTALLER'S INSTALLATION INSTRUCTIONS
Lighting the Unit

WARNING: If you do not follow these instructions exactly, a fire or explosion may result causing property damage, personal injury or loss of life.

- 1) This water heater does not have a pilot. It is equipped with a direct ignition device which automatically lights the burner. **DO NOT TRY TO LIGHT THE BURNER BY HAND.**
- 2) Before operating the Continuum 2424 smell all around the unit for gas. Be sure to smell near the ground as leaking gas may settle there.
- 3) Turn the manual gas control valve on.

STOP!! READ THE SAFETY ISSUES ON PAGES 8 & 9

- 4) Turn on any hot water tap. The Continuum 2424 should light and begin heating your water.

If the Continuum 2424 fails to light

- 1) **DO NOT ATTEMPT TO LIGHT BY HAND.**
- 2) Turn off the electrical power to the unit.
- 3) Turn off the manual gas control.
- 4) Wait 5 minutes, if you smell gas, go to a neighbor's house and call the gas company or the fire department. If you do not smell gas, go to the next step.
- 5) Turn the manual gas control valve on.
- 6) Turn the electrical power to the unit on.
- 7) Turn on any hot water tap.
- 8) If the unit still fails to light, turn off the electricity and gas to the unit and call Rinnai 1-800-621-9419.

INSTALLER'S INSTALLATION INSTRUCTIONS

Remote Controls- General

The remote controls for the Continuum 2424 allow the customer to control the functions of the water heater and to diagnose certain fault conditions.

The Main Controller model MC-45-3US is intended to be installed in the kitchen or laundry area where the majority of the hot water is being used.

NOTE: The MC-45-3US has a temperature setpoint range of 96-140°F. This is the only controller capable of temperature setpoints greater than 120°F.

The Bath Controller model BC-45-3US and Secondary Bath Controller model BSC-45-3US are intended to be installed in a bath room close to a shower or tub. Both of these controllers have temperature setpoint ranges of 96-120°F.

NOTE: Only one of each type of controller can be connected to one Continuum 2424 water heater. (i.e. Installations with two MC-45-3US, two BC-45-3US, or two BSC-45-3US controllers will not function properly.)

Before installing the remote controls, determine the most convenient location(s). When deciding on the best location for the remote controls, please consider the following items:

- 1) Place the controllers out of reach of small children.
- 2) Avoid locations where the controller(s) will become hot. (over the stove, near the oven or a radiant heater.
- 3) Avoid direct sunlight. (The digital monitor can be difficult to read in direct sunlight)
- 4) Avoid areas where the remote can be splashed with cooking water, oil or sauce.
- 5) The remote control cables carry low voltage, 12VDC digital.

Every installation is different

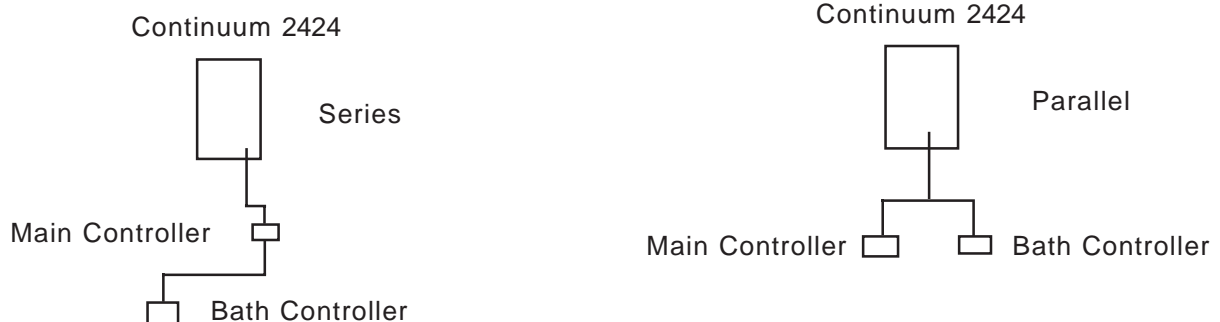

The controls can be wired in series or in parallel depending on the distance from the Continuum 2424 to the controls.

INSTALLER'S INSTALLATION INSTRUCTIONS
Remote Controls - Installation

- 1) Determine a suitable location for the control.
- 2) Make three holes on the wall as shown.
- 3) Run the cable between the control and the Continuum 2424 or the control and the other control.
- 4) Remove the face plate from the remote control, using a screw driver.
- 5) Connect the cable to the remote control.
- 6) Mount the control to the wall using the holes drilled in step 2.

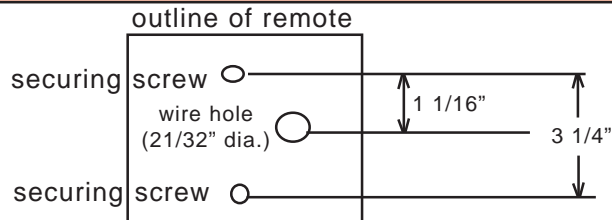

Note: Remote Control Dimensions are:
4 3/4" H x 4 3/4 W" x 1" D

- Note: If the cable cannot be run in the wall cavity, the plastic knockout should be removed from the top or bottom of the control to allow flush mounting with the wall
- 7) Disconnect the power from the Continuum 2424 .
 - 8) Remove the cover of the Continuum 2424 .
 - 9) Remove the plastic cover from the PCB and electrical connections.

DO NOT ATTEMPT TO CONNECT THE REMOTE CONTROLS WITH THE POWER ON, THERE'S 120 VOLT POTENTIAL, NEXT TO THE REMOTE CONTROL CONNECTIONS INSIDE THE UNIT. All service and wiring should be performed by a certified installer.

- 10) Thread the cable through the access hole at the base of the unit and connect the wires to the control terminals on the right hand side bottom of the PCB. **Note: Connect remote control cable to location labeled "TERMINAL" in the drawing at right.**
- 11) Secure the control cable using the clamp provided.
- 12) Replace plastic cover over PCB and then replace the cover of the Continuum 2424 .

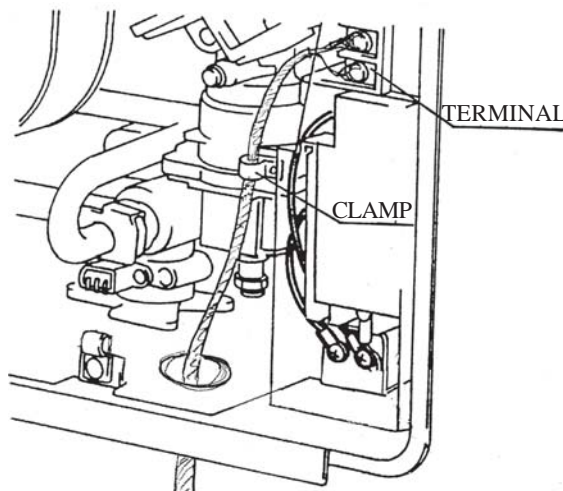



INSTALLER'S INSTALLATION INSTRUCTIONS

Testing

- 1) Turn on the gas and water.
- 2) Check for water and gas leaks. Use soapy water to test for gas leaks.
- 3) Remove pressure test point screw, attach pressure gauge to test point.
- 4) Turn Power on.
- 5) Open any hot water tap fully.
- 6) Check test point or supply pressure in water columns per inch.

<u>Manifold Pressure:</u>		<u>Supply pressure:</u>	
Natural Gas	5.3" Hi. fire	0.43" Lo. fire	Natural Gas Min. 7" Max. 10.5"
LPG	8.7" Hi. fire	0.59" Lo. fire	LPG Min. 10" Max. 14"

NOTE: The pressure may be low due to too little flow, too high an incoming temperature, and/or undersized gas piping. Examine these areas before determining that the pressure needs to be adjusted. **Contact Rinnai before adjusting manifold pressures at 1-800-621-9419. Failure to contact Rinnai, could void unit's warranty.**

- 7) If it is determined that the gas pressure needs adjusting, first check the incoming pressure at the test point on the gas inlet. If it is correct follow the adjusting procedure contained in the pouch of the unit EXACTLY. If in doubt call Rinnai 1-800-621-9419.

The regulator is pre-set at the factory, it should not need resetting.

- 8) Turn the hot water off. Turn the power off. Remove the pressure gauge and replace the test point screw. Check for a gas leak around the test point screw.
- 9) Replace the front cover.
- 10) Turn the power back on.
- 11) Check the operation of the unit. Check the operation of each of the remote controls. Check the operation of the Power failure protection system.
- 12) Explain the proper operation of the Continuum 2424 to the customer.



INSTALLER'S INSTALLATION INSTRUCTIONS
Diagnostic Points

Flow Chart N°	Measurement Point		Normal Value	Component
	Con N°	Wire Color		
1	J ₄	Brown - Blue	AC 108 - 132 V	Surge Protector
2	H ₁	Black - Black	DC 11 - 13 V	Remote Control
3	C ₂	Red - Black	DC 11 - 13 V	Water Flow Sensor
		Yellow - Black	DC 2 - 10 V	
4	D	White - Black	DC 2 - 9 V	Combustion Fan Motor
		Red - Yellow	60 - 350 Hz	
5	A ₂	Yellow - Cabinet Ground	AC 100 - 160 V (over DC 1μA)	Flame Rod
6	C ₁	White - White	Thermistor resistance value Temp Resistance 15°C 11.4 - 14.0 KΩ 30°C 6.4 - 7.8 KΩ 45°C 3.6 - 4.5 KΩ 60°C 2.2 - 2.7 KΩ 105°C 0.6 - 0.8 KΩ	Thermistor
7	B ₂	Red - Red	Below 1Ω	Thermal Fuse
8	B ₃	Red - Red	Below 1Ω	Over-heat Switch
9	I ₄	Grey - Grey	AC 90 - 110 V	Ignitor
10	I ₁	Pink - Black	DC 80 - 100 V 1.3 - 1.6 KΩ	Solenoid Valve (SV ₁)
11	I ₂	Yellow - Black	DC 80 - 100 V 1.7 - 2.1 KΩ	Solenoid Valve (SV ₂)
12	B ₁	Pink - Pink	DC 80 - 100 V 60 - 100 Ω	Modulating Valve
13	I ₃	Blue - Black	DC 80 - 100 V 1.7 - 2.1 KΩ	Solenoid Valve (SV ₃)
14	E ₁	Red - Blue Orange - Grey	DC 11 - 13 V	Geared Motor

Connector	Wire Color	Nomal Value			
J	Red - Black	AC 90 - 110 V 19 - 23 Ω	A	Brown-Grey	AC 30 - 50 V 2 - 4 Ω
F	Green - Green	AC 12 - 16V 3.6 - 4.8 Ω	J ₅	Black - White	AC 108 - 132 V 20 - 24 Ω
A	Orange - Orange	AC 13 - 30V 0.6 - 0.8 Ω	A	Yellow - Brown	AC 180 - 220 V 0.23 - 0.3 KΩ

INSTALLER'S INSTALLATION INSTRUCTIONS Schematic Diagram

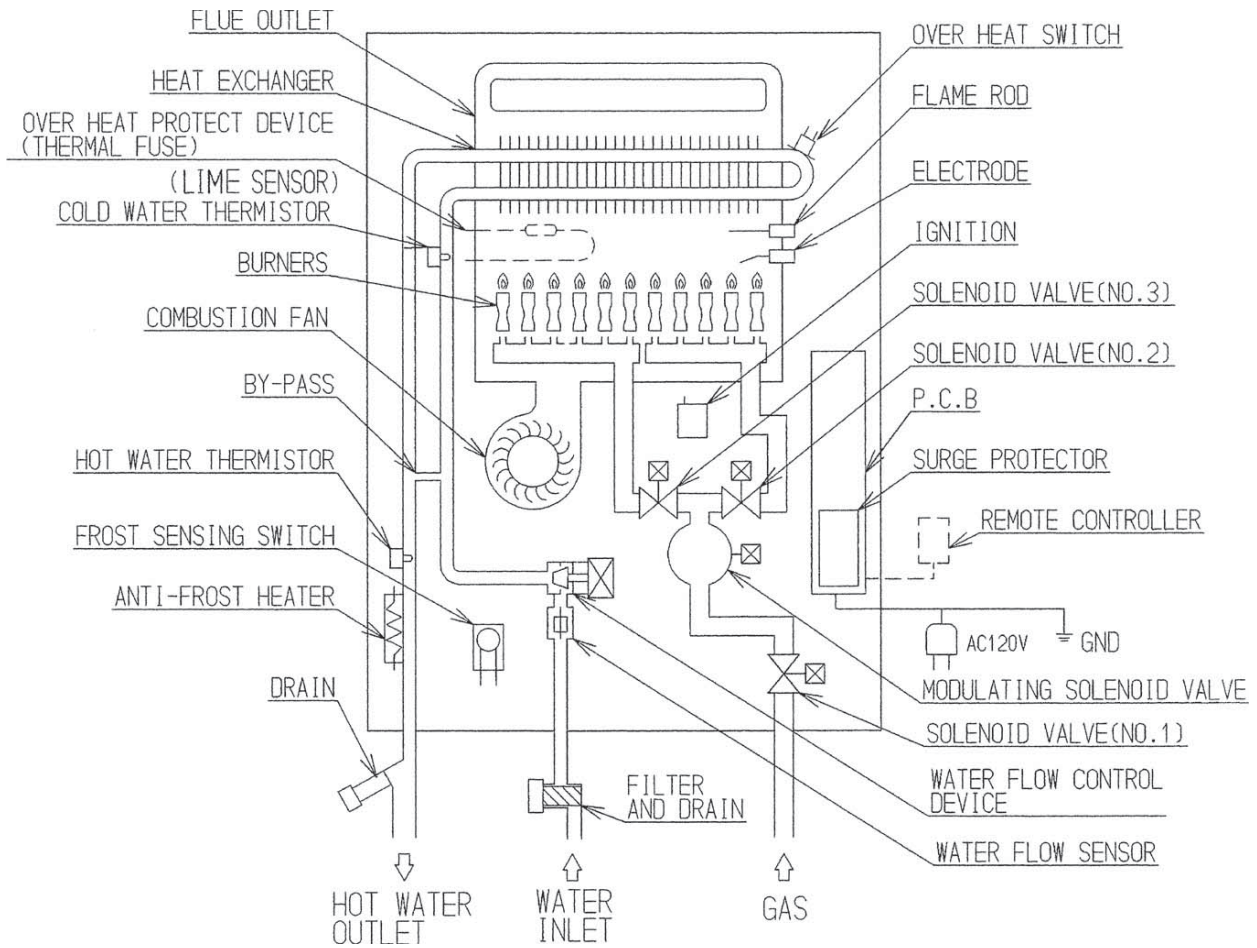

INSTALLER'S INSTALLATION INSTRUCTIONS Exploded View - Cabinet

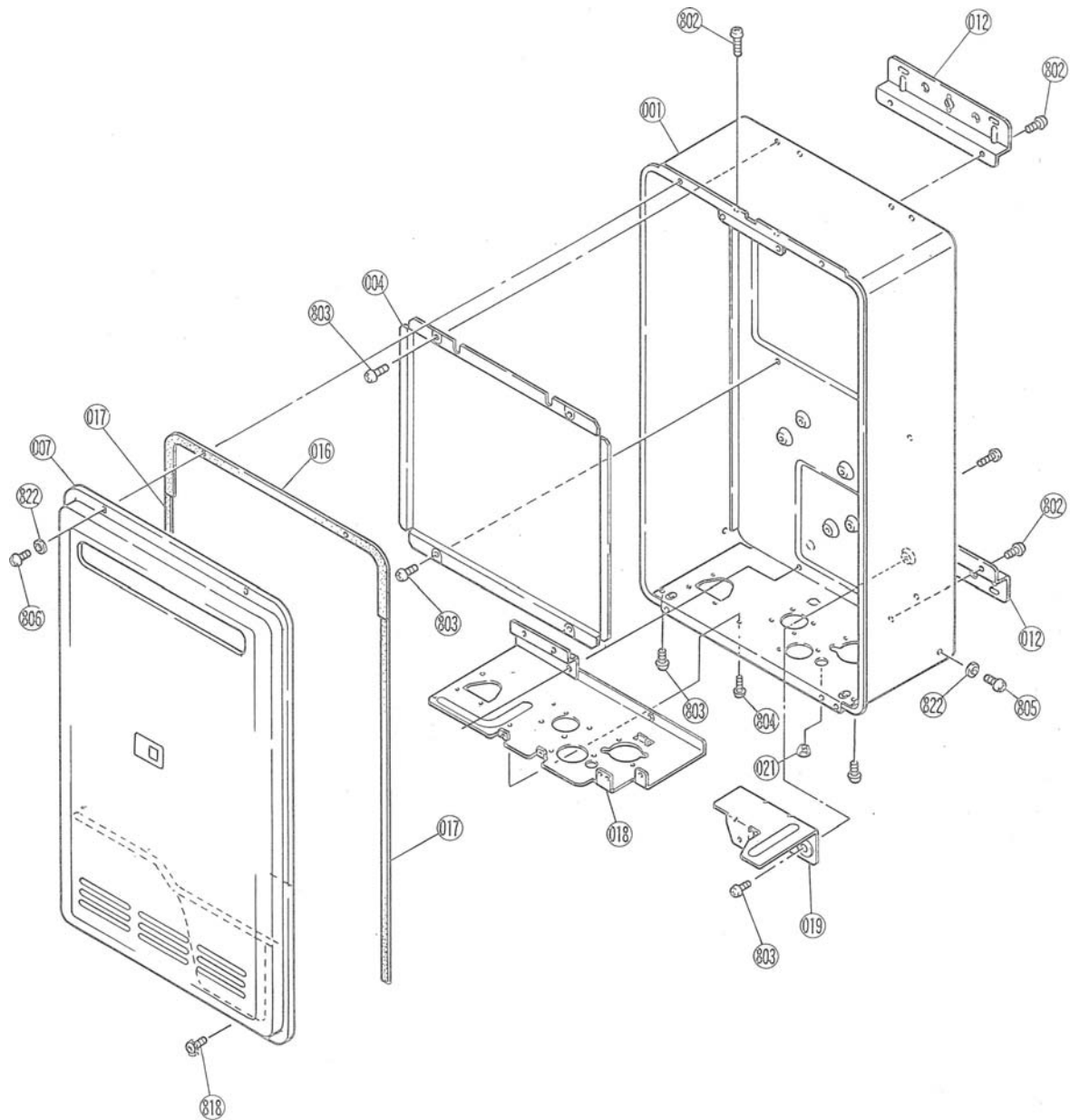

INSTALLER'S INSTALLATION INSTRUCTIONS Exploded View - Internals

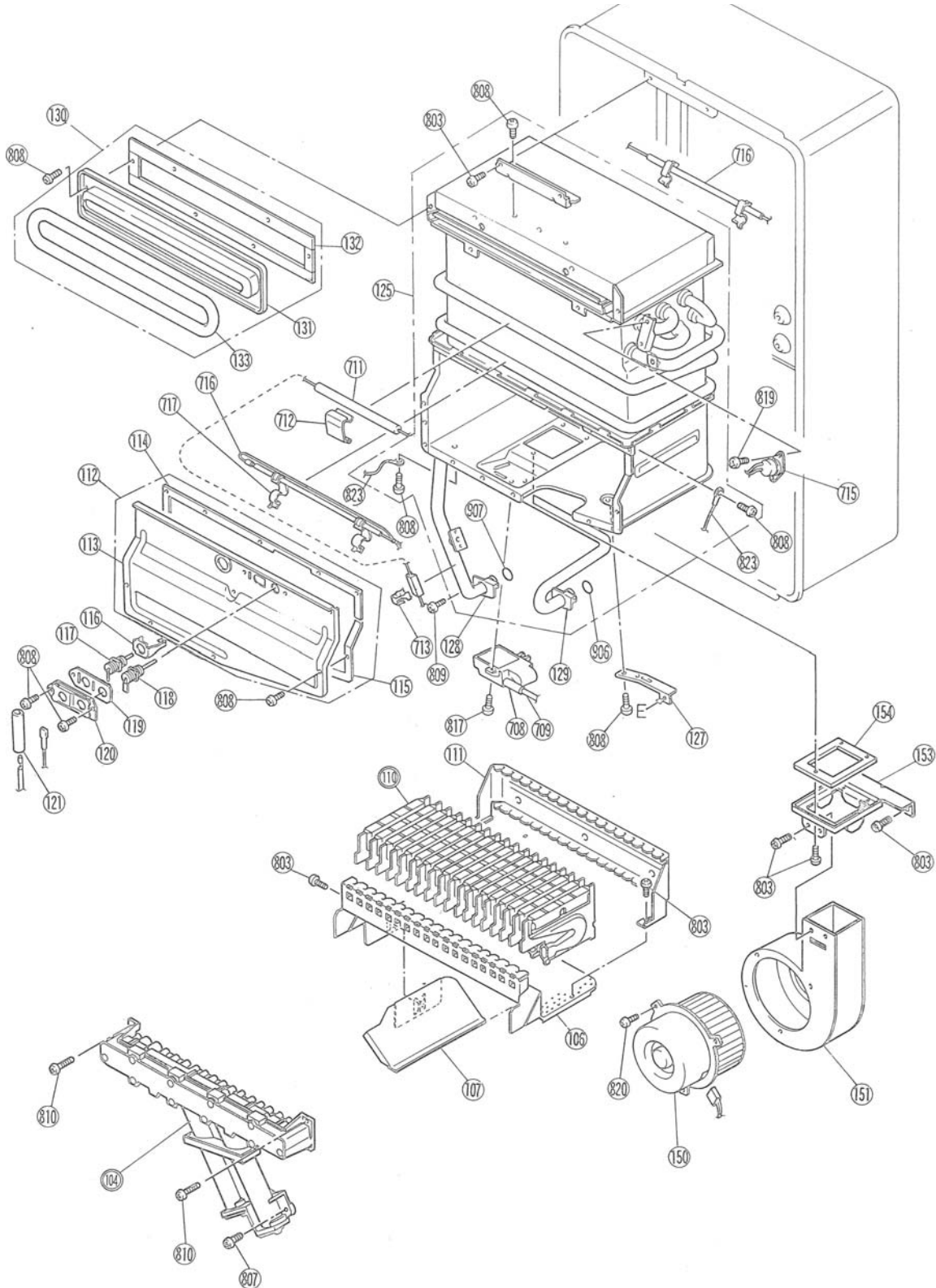

INSTALLER'S INSTALLATION INSTRUCTIONS Exploded View - Internals

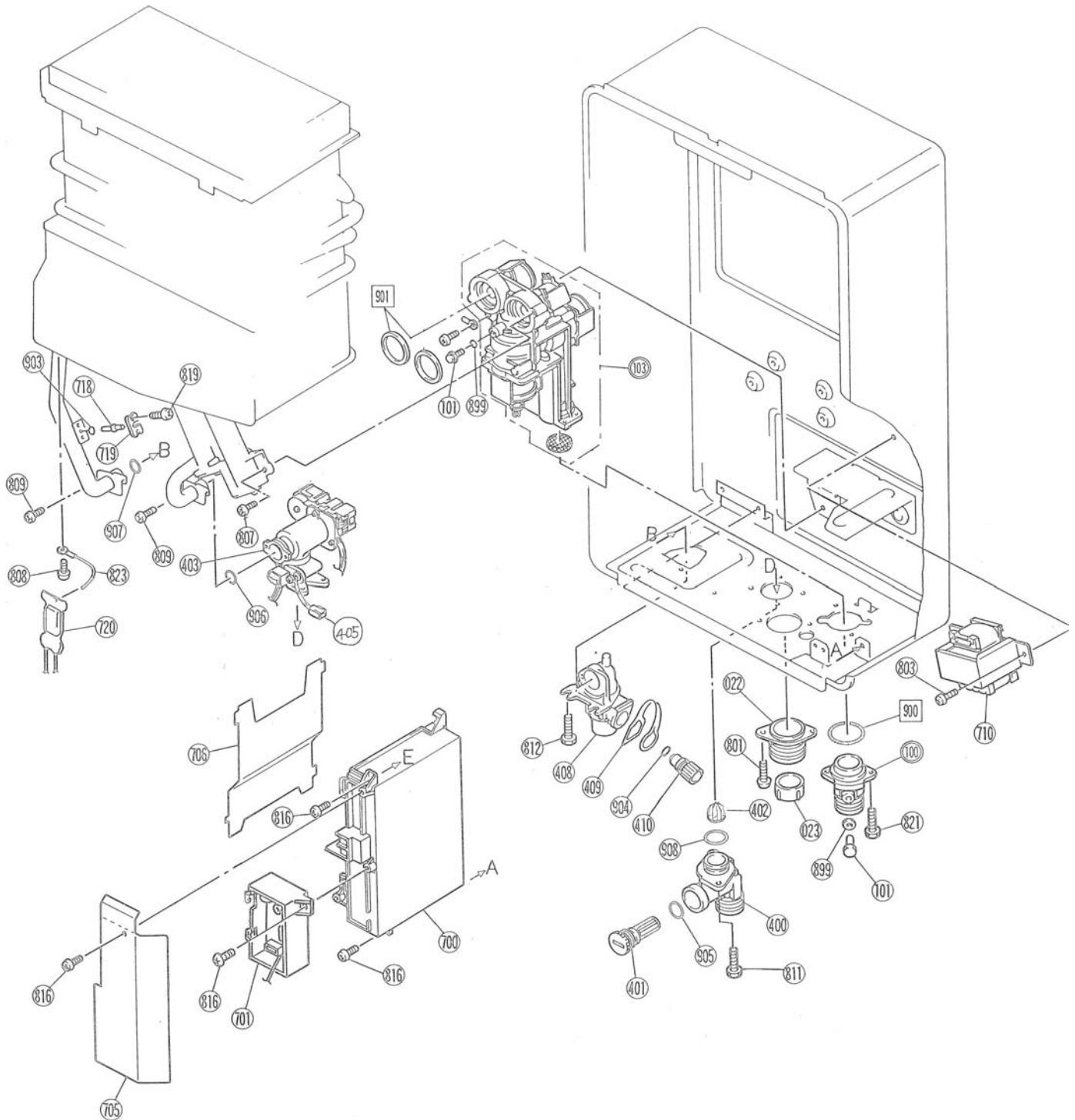

INSTALLER'S INSTALLATION INSTRUCTIONS Exploded View - Electrical

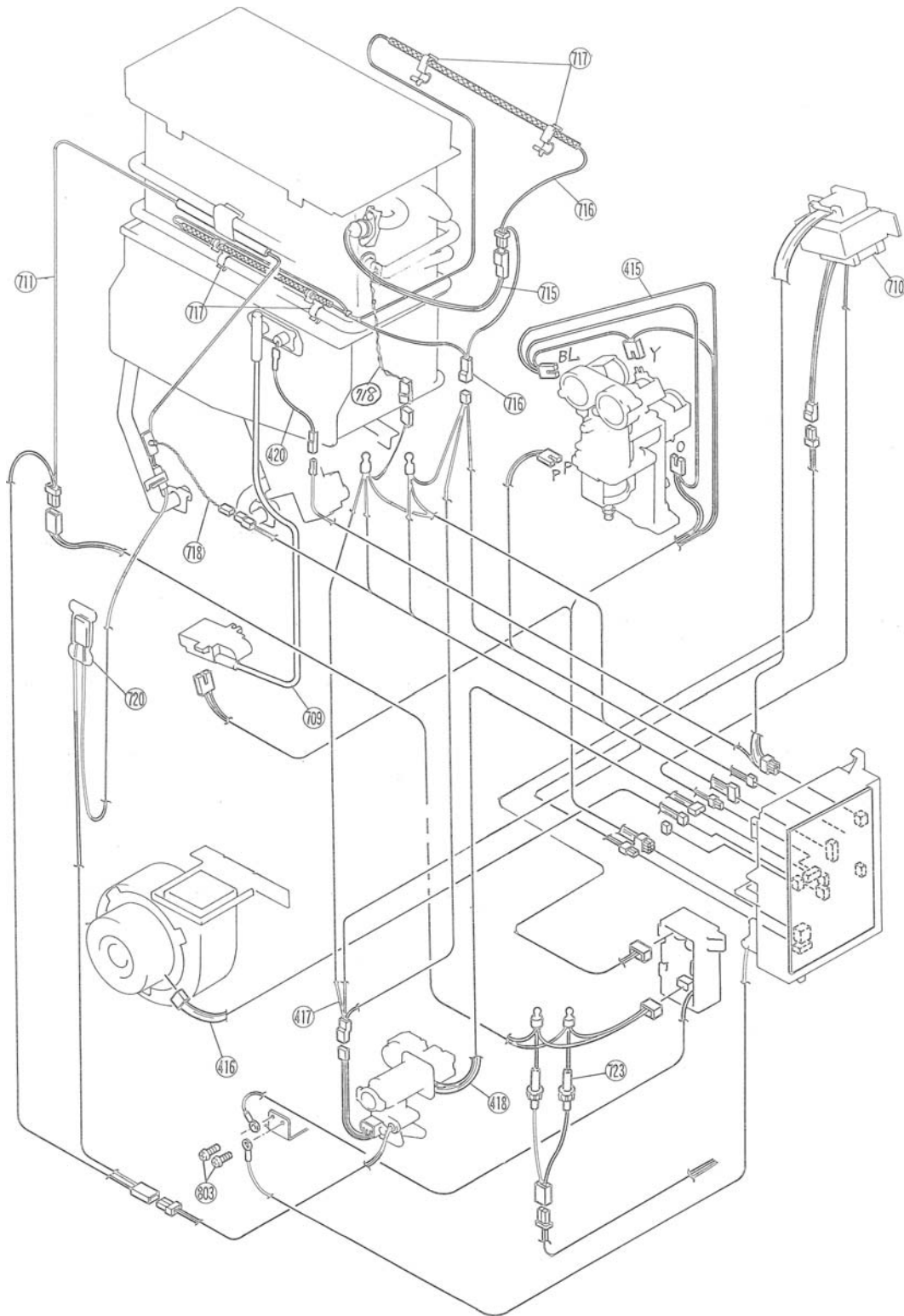



INSTALLER'S INSTALLATION INSTRUCTIONS
Parts List

<u>Number</u>	<u>Description</u>	<u>Part Number</u>	<u>Quantity</u>
001	Casing Assembly	DU195-100-2	1
004	Heat Protection Plate	BU155-110	1
007	Front Panel Assembly	DU195-1615-2	1
012	Wall Installation Bracket	BU195-121	2
016	Front Panel Packing	BU195-167	1
017	Front Panel Packing - Side	AU115-163	2
018	Connection Reinforcement Panel	BU169-120	1
019	Gas Control Bracket	BU169-125	1
022	Cable Connection	BU56-602-N	1
023	Cable Seal Packing	AU169-126	1
100	Gas Connection (3/4" NPT)B	CU195-211-2	1
101	Test Point Screw	C10D-5	2
103	Gas Control Assembly	C36E-30-S	1
104	Manifold Assembly - A (LPG)	CU195-200-A	1
104	Manifold Assembly - B (Nat)	CU195-200-B	1
106	Burner Case Front	DU195-255	1
107	Sound Proofing Panel	CU169-257	1
110	Side Type Sleeve Burner Assembly	B3A1-4	18
111	Burner Case Back Panel	CU169-256	1
112	Comb. Chamber Front Panel (Complete Assembly)	CU195-920	1
113	Comb, Chamber Front Panel (Assy)	CU195-310	1
114	Upper Packing - Comb. Chamber	BU195-315	1
115	Lower Packing - Comb. Chamber	BU195-316	1



INSTALLER'S INSTALLATION INSTRUCTIONS
Parts List

<u>Number</u>	<u>Description</u>	<u>Part Number</u>	<u>Quantity</u>
116	Ignition target	AU168-325	1
117	Electrode	AU168-321	1
118	Flame Rod	AU168-322	1
119	Electrode Packing	AU195-312	1
120	Electrode Holder	AH43-262	1
121	Electrode Sleeve	AU102-681	1
125	Heat Exchanger Complete Assy	DU195-1867	1
127	PCB Bracket	AU195-330	1
128	Stop Bracket A	AU195-321	1
129	Stop Bracket B	AU195-322	1
130	Flue Outlet (Assy)	BU169-470	1
131	Flue Outlet	BU169-471	1
132	Flue Outlet Packing	BU169-472	1
133	Flue Outlet Packing A	AU155-111-1	1
150	Blower Motor Assy	BU195-565	1
151	Fan Casing Assy A	BU169-552	1
153	Fan Connection	BU169-555	1
154	Fan Connection Packing	AU169-656	1
400	Water Inlet (3/4" NPT) B	H73-511	1
401	Water Filter Assy	H73-501-2	1
402	Rectifier	M8D1-11	1
403	Water Flow Servo & Sensor	M8E-4-4	1
405	120V Anti-Frost Heater	BU195-1878	1
408	Hot Water Outlet (3/4"NPT) C	BU132-363-C	1



INSTALLER'S INSTALLATION INSTRUCTIONS
Parts List

<u>Number</u>	<u>Description</u>	<u>Part Number</u>	<u>Quantity</u>
409	Plug Band B	AU142-445	1
410	Drain	AU142-444	1
415	Modulating Solenoid Valve Harness	BU195-601	1
416	Fan Motor Harness	BU195-602	1
417	Sensor Harness	BU195-1877	1
418	Water Flow Servo Harness	BU195-604	1
420	Flame Rod Harness	BU195-605	1
700	PCB	CU195-1870	1
701	Surge Protector	BBF9-630	1
705	PCB Front Cover	BU168-707	1
706	PCB Side Cover	BU195-507	1
708	Ignitor	EI-144	1
709	High Tension Cord	BH38-710-200	1
710	Transformer	ET-259	1
711	120V Anti-Frost Heater B	BU195-1879	1
712	Anti-Frost Heater Clip	AU195-675	2
713	Anti-Frost Heater Clip	AU100-721	3
715	Over Heat Switch	BU129-824-2	1
716	Thermal Fuse Harness	CU195-610-2	1
717	Thermal Fuse Clips	CP-80531	6
718	Thermistor	BH45-650	2
719	Thermistor Clip	CP-90172	2
720	Frost Sensing Switch	BU189-530	1
723	3 Amp Fuse Harness	BU195-1630	1



INSTALLER'S INSTALLATION INSTRUCTIONS
Parts List

<u>Number</u>	<u>Description</u>	<u>Part Number</u>	<u>Quantity</u>
801	Screw	ZBA041OUK	–
802	Screw	ZBA051OUK	–
803	Screw	ZEAB0408SZ	–
804	Screw	ZBA0408UK	–
805	Screw	ZBD0408UK	–
806	Screw	ZAD0408UK	–
807	Screw	CP-21478-412	–
808	Screw	ZEA0408UK	–
809	Screw	ZAA0408UK	–
810	Screw	ZBA0412UK	–
811	Screw	ZAG0512UK	–
812	Screw	ZBA0512UK	–
816	Screw	ZEDB0408SZ	–
817	Screw	CP-80452	–
819	Screw	ZEAB0406UK	–
820	Screw	ZIAA0410SZ	–
821	Screw	ZAG0514UK	–
822	Washer	CF83-41430	–
823	Tie backs	CP-90331	–
899	“O” Ring (S4)	M10B-13-4	2
900	“O” Ring (P24)	M10B-1-24	1
901	Packing	C36F8-1	2
903	“O” Ring (P4)	MIOB-2-4	1
904	“O” Ring (P7)	MIOB-2-7	1



INSTALLER'S INSTALLATION INSTRUCTIONS
Parts List

<u>Number</u>	<u>Description</u>	<u>Part Number</u>	<u>Quantity</u>
905	"O" Ring (P16)	M10B-2-16	1
906	"O" Ring (P12.5)	M10B-2-12.5	1
907	"O" Ring (P14)	M10B-2-14	1
908	"O" Ring (P18)	M10B-2-18	1
	Manual 3/4" gas control valve	BU195-1865	1
	Kitchen remote control kit	MC-45-3US	1
	Bathroom Remote Control kit	BC-45-3US	1
	2nd Bathroom Remote Control kit	BSC-45-3US	1
	View Window Sticker	AU195-1680-2	1
	Continuum Label	BU195-1882X01	1
	Model Number Label	AU195-1881	1
	Wiring Diagram	CU195-1887	1
	Manifold Seal	AU169-206X02	1
	Rating Plate (NG)	CU195-1889-1X03	1
	Rating Plate (LP)	CU195-1889-2X03	1
	Warning Label	CU195-1886X01	1
	Warning Repair Label	AU195-1890	1
	Gas Type Label (NG)	CP-71201X01	1
	Gas Type Label (LP)	CP-71571X01	1
	Gas Type Label (Bottom of Unit - NG)	CP-71070	1
	Gas Type Label (Bottom of Unit - LP)	CP-71572	1



INSTALLER'S INSTALLATION INSTRUCTIONS
Notes

Ask about Rinnai's other fine products:

The Silent Servant

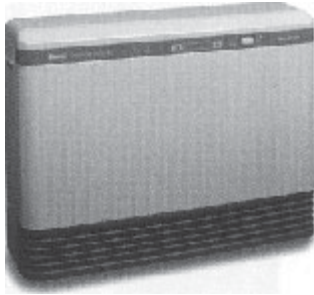

*North America's only vent-free convection heater

*99% efficient

*whisper quiet

*perfect for hard to heat areas

The Energy Savers

*Direct Vent Heating with style and performance

*whisper quiet

*available with multi-step set back thermostats



The Infra-reds

*Vent free radiant heaters

*99.9% efficient

*Heat like the sun

Portable Cooking Products

*One, two and two burner with broiler models.

*Perfect for camping, a picnic or a tailgate party



Rinnai

www.rinnaiamerica.com

800-621-9419

BU195 - 1892X04
Printed in Japan 2001.3