

Remote Controller

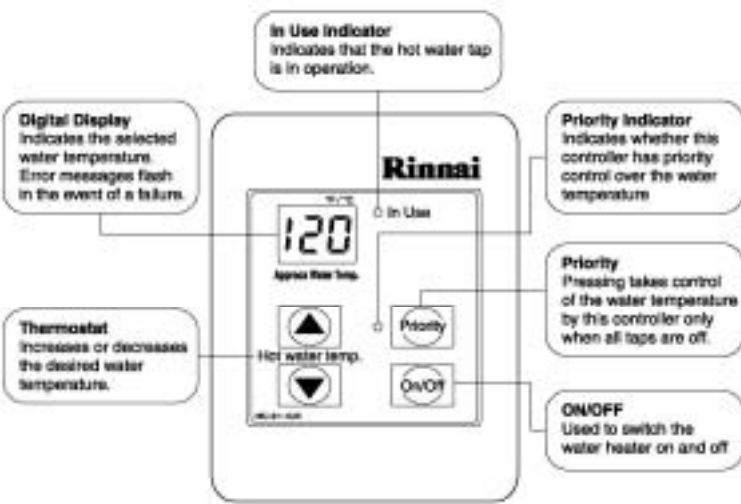

Diagnostic Use of Controller

- To Display Maintenance Codes: Press the 'On/Off' button once to turn the controller off. Press and hold the 'On/Off' button followed by the thermostat button to cycle through the maintenance codes.
- To Display Water Flow through the water heater: Press the thermostat button and hold for 2 seconds and then press the 'On/Off' button while continuing to hold the thermostat button.
- To Display Outlet Water Temperature: Press the thermostat button and hold for 2 seconds and then press the 'On/Off' button while continuing to hold the thermostat button.

To Change the Temperature Display from °F to °C (or °C to °F)

- Press the 'On/Off' button once to turn the controller off. With the controller off press and hold the 'On/Off' button until the display changes to °C (°F), approximately 5 seconds.

To Turn Off the Sound (Mute)

- To turn the sound off (mute) press and hold both the thermostat buttons until an audible "beep" is heard, approximately 5 seconds.

GAS PRESSURE SETTING

(Ensure gas pressure check under Commissioning has been completed first!)
The regulator is electronically controlled and factory pre-set. Under normal circumstances it does not require adjustment during installation. Make adjustments only if the unit is not operating correctly and all other possible causes for incorrect operation have been eliminated.

- Turn 'OFF' the gas supply.
- Turn 'ON' 120V power supply.
- Remove the front cover from the appliance.
- Check gas type using data plate on side of unit. If using spare PC board, check gas type switches (Fig.1) are in the correct position. (dip switch 1 of SW2 'ON' = NG, 'OFF' = LPG) See Dip Switch Settings section below.
- Note: 'ON' towards right, 'OFF' towards left.
- Attach pressure gauge to burner test point, located on the gas control. (Fig.2).
- Turn 'ON' the gas supply.
- Turn 'ON' 120V power supply.
- If remote controllers are fitted, turn the unit 'ON' at the controller, select the maximum delivery temperature and open all available hot water taps full including the shower. (CAUTION: Ensure building occupants do not have access to hot water outlets during this procedure).
- Set the Rinnai Water Heater to 'Forced Low' combustion by setting No.7 dip switch of the (SW1) set of dip switches to 'ON'. (Fig.3).
- Check the burner test point pressure.
- Remove rubber access plug and adjust the regulator screw on the modulating valve (Fig.4) as required in Table 1. Replace rubber access plug.
- Set the Rinnai Water Heater to 'Forced High' combustion by setting both No. 7 and No. 8 dip switches of the bottom (SW1) set to 'ON'. (Fig.5). **Ensure maximum water flow!**
- Check the burner test point pressure.
- Adjust the high pressure Potentiometer (POT) on the Printed Circuit Board (PCB) as required to the pressure shown in Table 1.

IMPORTANT: Set dip switches 7 and 8 on the bottom (SW1) to 'OFF' to return the appliance to 'Normal' combustion. (Fig. 6).

- Close hot water tap.
- Turn 'OFF' the gas supply and 120V power supply.
- Remove pressure gauge & replacing sealing screw.
- Turn 'ON' the gas supply and 120V power supply.
- Operate unit and check for gas leaks at test point.
- Replace the front cover of the appliance.

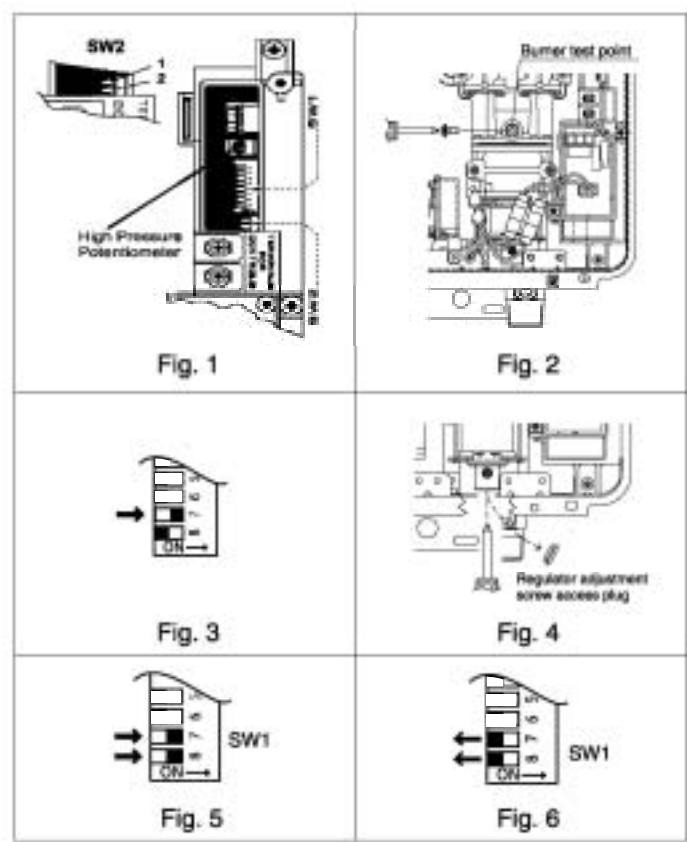

Gas Pressure Setting

NOTE: For additional installation and commissioning information refer to Operation / Installation Manual

WARNING

THIS APPLIANCE MUST BE INSTALLED, SERVICED AND REMOVED BY AN AUTHORISED PERSON DURING PRESSURE TESTING OF THE CONSUMER PIPING ENSURE GAS COCK SITUATED BEFORE UNIT IS SHUT-OFF. FAILURE TO DO SO MAY RESULT IN SERIOUS DAMAGE TO THE APPLIANCE AND POSSIBLE INJURY.

APPLIANCE OPERATING PRESSURES

	Water Inlet Max	Gas Inlet Min./Max		Forced Low		Forced High	
		NAT.G	LPG	NAT.G	LPG	NAT.G	LPG
R50LSi						2.0"W.C.	3.2"W.C.
R75LSi	150 PSI	5"W.C. /10.5"W.C.	8"W.C. /13.5"W.C.	0.52"W.C.	0.92"W.C.	2.7"W.C.	4.4"W.C.
R94LSi						3.3"W.C.	5.0"W.C.

COMMISSIONING

With all gas appliances in operation at maximum gas rate, the flowing inlet pressure at the incoming test point on the Rinnai Water Heater should read 5"W.C. - 10.5"W.C. on Natural Gas and 8"W.C. - 13.5"W.C. on Propane Gas. If the pressure is lower, the gas supply is inadequate and the appliance unit will not operate to specification. Check gas meter, regulator and pipework for correct operation/sizing and rectify as required.

Error Codes

- 02 No burner operation during freeze protection mode**
 - Service Call
- 03 Power interruption during Bath fill (Water will not flow when power returns)**
 - Turn off all hot water taps. Press ON/OFF twice.
- 10 Air Supply or Exhaust Blockage**
 - Ensure Rinnai approved venting materials are being used.
 - Check that nothing is blocking the flue inlet or exhaust.
 - Check all vent components for proper connections.
 - Ensure vent length is within limits.
 - Ensure condensation collar was installed correctly.
 - Verify dip switches are set properly.
 - Check fan for blockage.
- 11 No Ignition**
 - Check that the gas is turned on at the water heater, gas meter, or cylinder.
 - Ensure gas type and pressure is correct.
 - Ensure gas line, meter, and/or regulator is sized properly.
 - Bleed all air from gas lines.
 - Verify dip switches are set properly.
 - Ensure appliance is properly grounded.
 - Disconnect EZConnect or MSA controls to isolate the problem.
 - Ensure igniter is operational.
 - Check igniter wiring harness for damage.
 - Check gas solenoid valves for open or short circuits.
 - Remove burner cover and ensure all burners are properly seated.
 - Remove burner plate and inspect burner surface for condensation or debris.
- 12 Flame Failure**
 - Check that the gas is turned on at the water heater and gas meter. Check for obstructions in the flue outlet.
 - Ensure gas line, meter, and/or regulator is sized properly.
 - Ensure gas type and pressure is correct.
 - Bleed all air from gas lines.
 - Ensure proper Rinnai venting material was installed.
 - Ensure condensation collar was installed properly.
 - Ensure vent length is within limits.
 - Verify dip switches are set properly.
 - Ensure appliance is properly grounded.
 - Disconnect keypad.
 - Disconnect EZConnect or MSA controls to isolate the problem.
 - Check power supply for loose connections.
 - Check power supply for proper voltage and voltage drops.
 - Ensure flame rod wire is connected.
 - Check flame rod for carbon build-up.
 - Disconnect and re-connect all wiring harnesses on unit and PC board.
 - Check all components for electrical short.
 - Check gas solenoid valves for open or short circuits.
 - Remove burner plate and inspect burner surface for condensation or debris.
- 14 Thermal Fuse**
 - Check gas type of unit and ensure it matches gas type being used.
 - Check for restrictions in air flow around unit and vent terminal.
 - Check for low water flow in a circulating system causing short-cycling.
 - Ensure dip switches are set to the proper position.
 - Check for foreign materials in combustion chamber and/or exhaust piping.
 - Check heat exchanger for cracks and/or separations.
 - Check heat exchanger surface for hot spots which indicate blockage due to scale build-up. Refer to instructions in manual for flushing heat exchanger.
 - Measure resistance of safety circuit.
 - Ensure high fire and low fire manifold pressure is correct.
 - Check for improper conversion of product.
- 16 Over Temperature Warning**
 - Check for restrictions in air flow around unit and vent terminal.
 - Check for low water flow in a circulating system causing short-cycling.
 - Check for foreign materials in combustion chamber and/or exhaust piping.
 - Check for clogged heat exchanger.
- 32 Outgoing Water Temperature Sensor Fault**
 - Check sensor wiring for damage.
 - Measure resistance of sensor.
 - Clean sensor of scale build up.
 - Replace sensor.
- 33 Heat Exchanger Outgoing Temperature Sensor Fault**
 - Check sensor wiring for damage.
 - Measure resistance of sensor.
 - Clean sensor of scale build up.
 - Replace sensor.
- 34 Combustion Air Temperature Sensor Fault**
 - Check for restrictions in air flow around unit and vent terminal.
 - Check sensor wiring for damage.
 - Measure resistance of sensor.
 - Clean sensor of scale build up.
 - Ensure fan blade is tight on motor shaft and is in good condition.
 - Replace sensor.
- 52 Modulating Solenoid Valve Signal Abnormal**
 - Check modulating gas solenoid valve wiring harness for loose or damage terminals.
 - Measure resistance of valve coil.
- 61 Combustion Fan Failure**
 - Ensure fan will turn freely.
 - Check wiring harness to motor for damaged and/or loose connections.
 - Measure resistance of motor winding.
- 65 Water Flow Servo Faulty (does not stop flow properly)**
 - If blank screen is present on remote control then the flow control has shorted out. Unplug flow control. If remote lights up and unit starts operating then replace flow control assembly.
- 71 SV0, SV1, SV2, and SV3 Solenoid Valve Circuit Fault**
 - Check wiring harness to all solenoids for damage and/or loose connections.
 - Measure resistance of each solenoid valve coil.
- 72 Flame Sensing Device Fault**
 - Ensure flame rod is touching flame when unit fires.
 - Check all wiring to flame rod for damage.
 - Remove flame rod and check for carbon build-up; clean with sand paper.
 - Check inside burner chamber for any foreign material blocking flame at flame rod.
 - Measure micro amp output of sensor circuit with flame present.
 - Replace flame rod.
- LC Scale Build-up in Heat Exchanger** (when checking maintenance code history "00" is substituted for "LC")
 - Flush heat exchanger. Refer to instructions in manual.
 - Replace heat exchanger.
- No Code** (Nothing happens when water flow is activated.)
 - Clean inlet water supply filter.
 - On new installations ensure hot and cold water lines are not reversed.
 - Check for bleed over. Isolate unit from building by turning off hot water line to building. Isolate the circulating system if present. Open your pressure relief valve; if unit fires, there is bleed over in your plumbing.
 - Ensure you have at least the minimum flow rate required to fire unit.
 - Ensure turbine spins freely.
 - Measure the resistance of the water flow control sensor.
 - Remote control does not light up but you have 12 VDC at the terminals for controls.

Troubleshooting

IMPORTANT SAFETY NOTES:

There are a number of (live) tests that are required when fault finding this product. Extreme care should be used at all times to avoid contact with energized components inside the water heater. Only trained and qualified service agencies should attempt to repair this product. Remember, before checking for resistance readings, you should disconnect the power source to the unit and isolate the item to be checked from the circuit (unplug it).

(SV1, SV2, SV3 and POV) Gas valve and Modulating solenoids: (Set meter above 2K)

Wire color	Voltage	Resistance	Connector #	Pin #s
(Main) Pink - Black	11 - 13VDC	36.8 - 44.8 ohms	H5	6 - 7
(SV1) Black - Yellow	11 - 13VDC	36.8 - 44.8 ohms	H6	5 - 6
(SV2) Black - Blue	11 - 13VDC	36.8 - 44.8 ohms	H7	4 - 6
(SV3) Black - Brown	11 - 13VDC	36.8 - 44.8 ohms	H8	3 - 6
(POV) Pink - Pink	2 - 15VDC	67 - 81 ohms	H3	9 - 10

(M) Water Flow Control Device Servo or Geared Motor:

Wire color	Voltage	Resistance	Connector #	Pin #s
Red - Blue	11 - 13VDC	22 - 28 ohms	F7	9 - 10
Grey - Brown	4 - 6VDC	N/A	F7	5 - 7
Grey - Yellow	N/A	N/A	F7	5 - 8

NOTE: The grey wire listed above turns to black at F connector on the PCB.

(QS) Water Flow Sensor:

Wire color	Voltage	Resistance	Connector #	Pin #s
Black - Red	11 - 13VDC	5.5 - 6.2 K ohms	F2	1 - 3
Yellow - Black	4 - 7VDC	1 - 1.4 Mega ohms	F2	2 - 3

By-pass Flow Control (By-pass servo model ONLY):

Wire color	Voltage	Resistance	Connector #	Pin #s
Brown - White	11 - 13VDC	22 - 28 ohms	G1	1 - 5
Orange - White	2 - 6VDC	15 - 35 ohms	G1	2 - 5
Yellow - White	(Unit in operating mode)		G1	3 - 5
Red - White - Ground			G1	4 - 5

(IG) Ignition System:

Wire color	Voltage	Resistance	Connector #	Pin #s
Grey - Grey	90 - 110VAC	N/A	C1	1 - 2

(FM) Combustion Fan Motor:

Wire color	Voltage	Resistance	Connector #	Pin #s
Red - Black	6 - 45VDC	N/A	E1	1 - 2
White - Black	5 - 10VDC	9.2 - 9.4 K ohms	E1	2 - 4
Yellow - Black	11 - 13VDC	3.5 - 3.9 K ohms	E1	2 - 3

Set your meter to the hertz scale. Reading across the white and black wires at terminals 2 and 4 you should read between 60 and 420 hertz.

Thermal Fuse / Overheat Switch:

Wire color	Voltage	Resistance	Connector #	Pin #s
Red - Red	11 - 13VDC	Below 1 ohms	F6	H1
			F6	H12

Flame Rod:

Place one lead of your meter to the flame rod and the other to earth or ground. With the unit running you should read between 5 - 150 VAC. Set your meter to the μ amp scale, series your meter in line with the flame rod. You should read μ or greater for proper flame circuit. In the event of low flame circuit remove the flame rod and check for carbon and/or damage.

Heat Exchanger, Air Temperature, and Outgoing Water Temperature Thermistors:

Check all thermistors by inserting meter leads into each end of the thermistor plug. Set your meter to the 20K scale and read resistance. You should be able to apply heat to the thermistor bulb and see the resistance decrease. Then apply some ice to the thermistor and the resistance should increase. See below for examples of temperatures and resistance reading at those temperatures.

Example: 59°F = 11.4 - 14K Ω	140°F = 2.2 - 2.7K Ω
86°F = 6.4 - 7.8K Ω	221°F = 0.6 - 0.8K Ω
113°F = 3.6 - 4.5K Ω	

Outgoing Water Thermistor:

White - White	N/A	See example above	F5	3 - 4
---------------	-----	-------------------	----	-------

Heat Exchanger Temperature Thermistor:

Pink - White	N/A	See example above	F4	3 - 11
--------------	-----	-------------------	----	--------

Intake Air Thermistor (Indoor model ONLY)

Orange - White	N/A	See example above	F3	3 - 12
----------------	-----	-------------------	----	--------

Surge Protector:

Black - White	108 - 132 VAC	N/A	D2	1 - 3
Blue - Brown	108 - 132 VAC	N/A	D1	1 - 3

With the power off you can check the continuity through the surge protector. Place one meter lead on the top pin #1 of the surge protector and pin #3 on the bottom of the surge protector. Then check across top pin #3 and bottom pin #1. If you read continuity across these two points the surge protector is good. If you do not get continuity, replace the surge protector.

Remote Controls:

Terminals B1	10 - 13VDC	1.5 - 3.0 K ohms	B	1 - 3
--------------	------------	------------------	---	-------

Frost Protection:

This unit has five frost protection heaters mounted at different points inside the unit, to protect the water heater from freeze ups. There are two heaters located on the outlet hot water line next to the thermistor.

Using a voltage meter set on the 200 ohm scale, you should have a resistance reading of 123 - 137 ohms through each of these heaters. The heater located on the heat exchanger piping should have a resistance reading of 109 - 121 ohms and the one located in the water flow sensor valve has a resistance reading of 14 - 16 ohms. The one located in the outlet valve has a resistance reading of 14 - 16. Voltage throughout this circuit should be 120 VAC.

Amp Fuses:

This unit has an inline (3) amp glass fuse. Remove the fuse and check continuity through it. If you have Continuity through the fuse, it is good. If you can not read continuity, the fuse is blown and must be replaced.

Dip Switches Settings

Adjust switches 2 and 3 in the bank of 8 depending on your altitude according to the table below.

The original PC boards on the water heaters do not have the bank of 6 dip switches. Only spare PC boards have this bank.

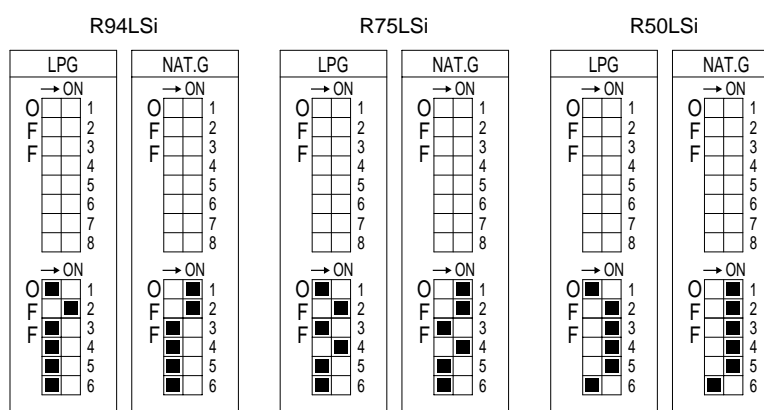

WARNING

DO NOT adjust the other dip switches unless specifically instructed to do so. Incorrect Dip Switch Settings can cause the Rinnai water heater to operate in an unsafe condition and may damage the water heater and void the warranty.

SW No.	NOTES
2	Level 0 0-2000ft (0-610m)
3	Level 1 2001-5200ft (610-1585m)
	Level 2 5201-7800ft (1585-2377m)
	Level 3 7801-10200ft (2377-3109m)

Wiring Diagram

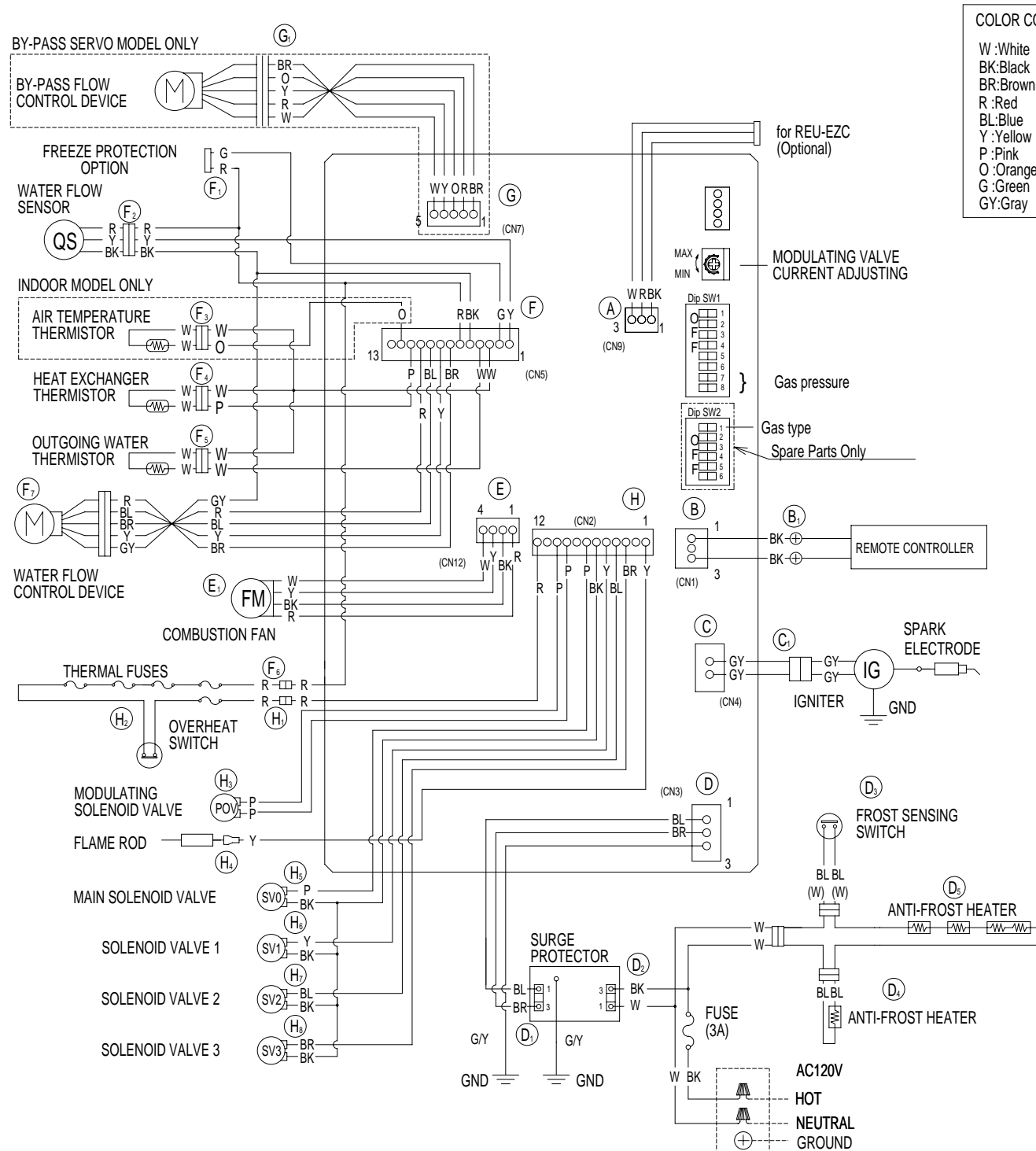

070 00012 36781 1

R50LSi
R75LSi
R94LSi

U287-078(00)

EXPLODED VIEW - CABINET

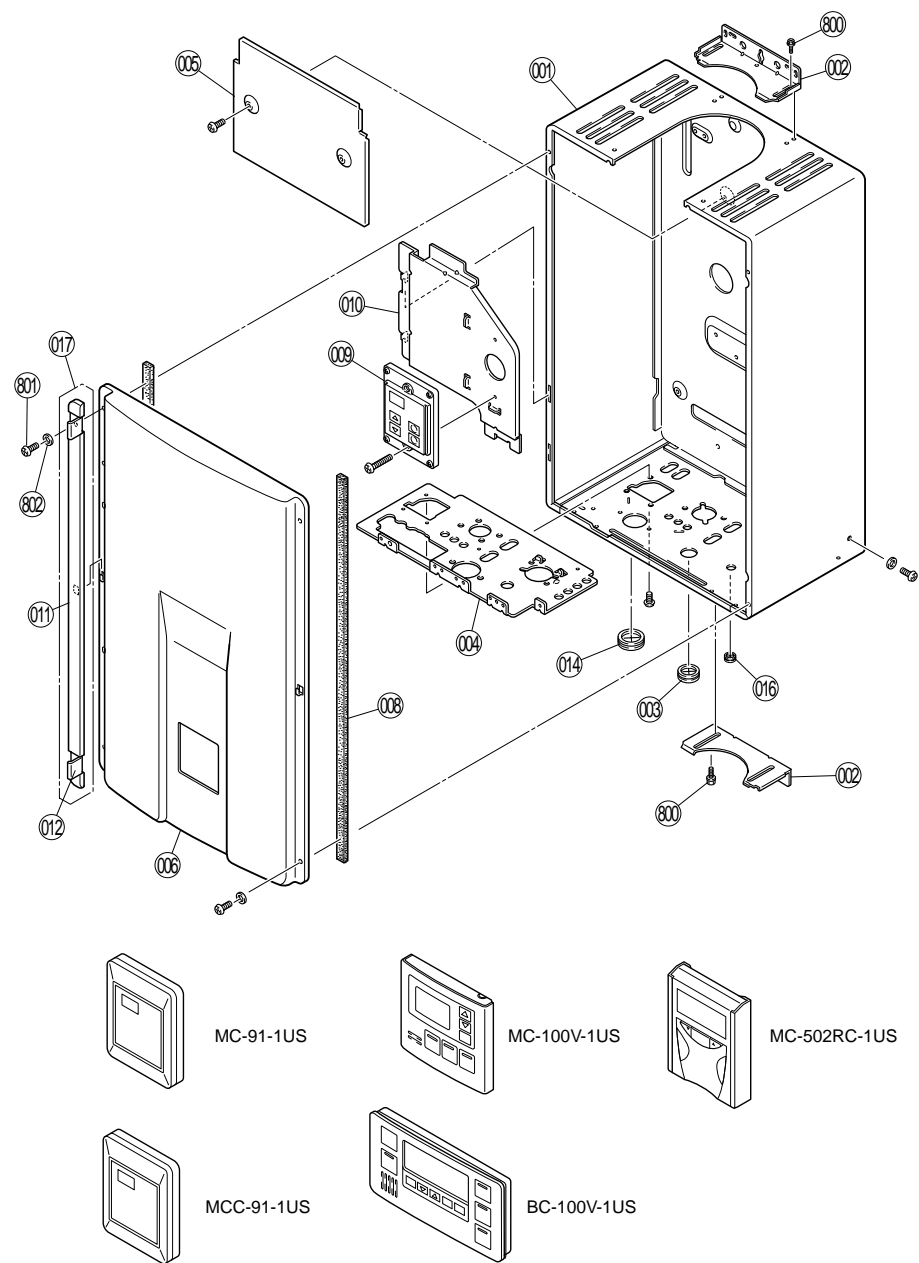

EXPLODED VIEW - INTERNALS

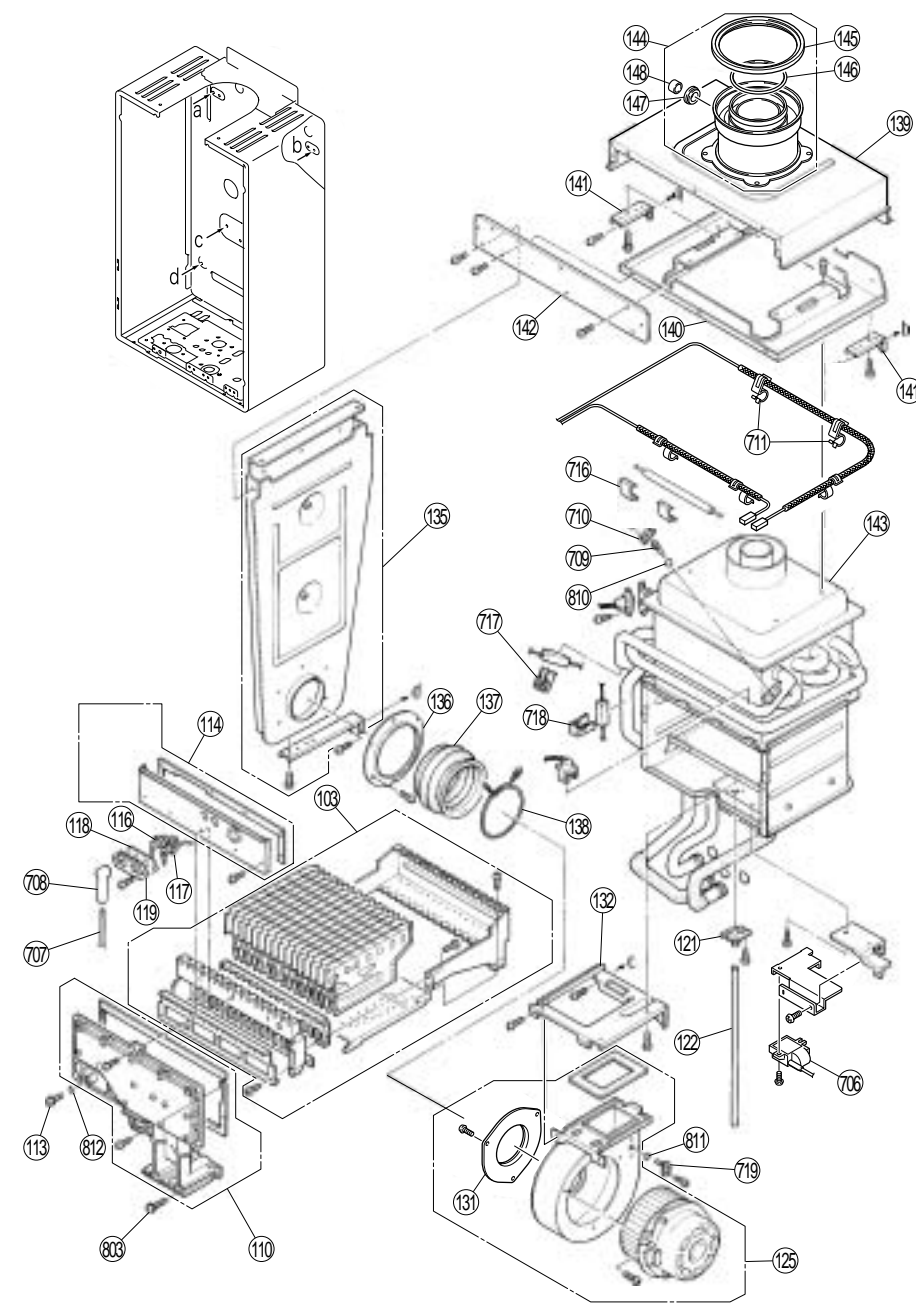

EXPLODED VIEW - INTERNALS

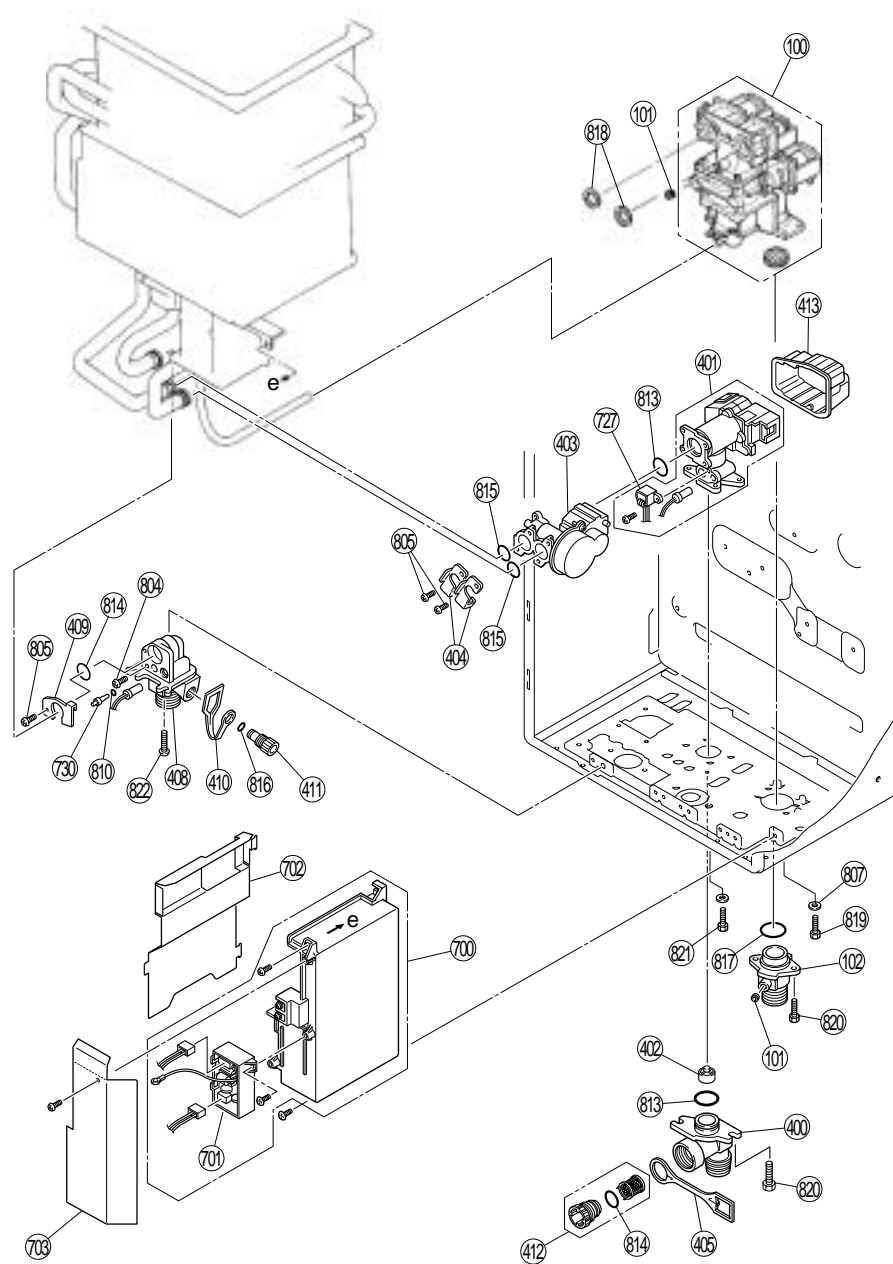

EXPLODED VIEW - ELECTRICAL

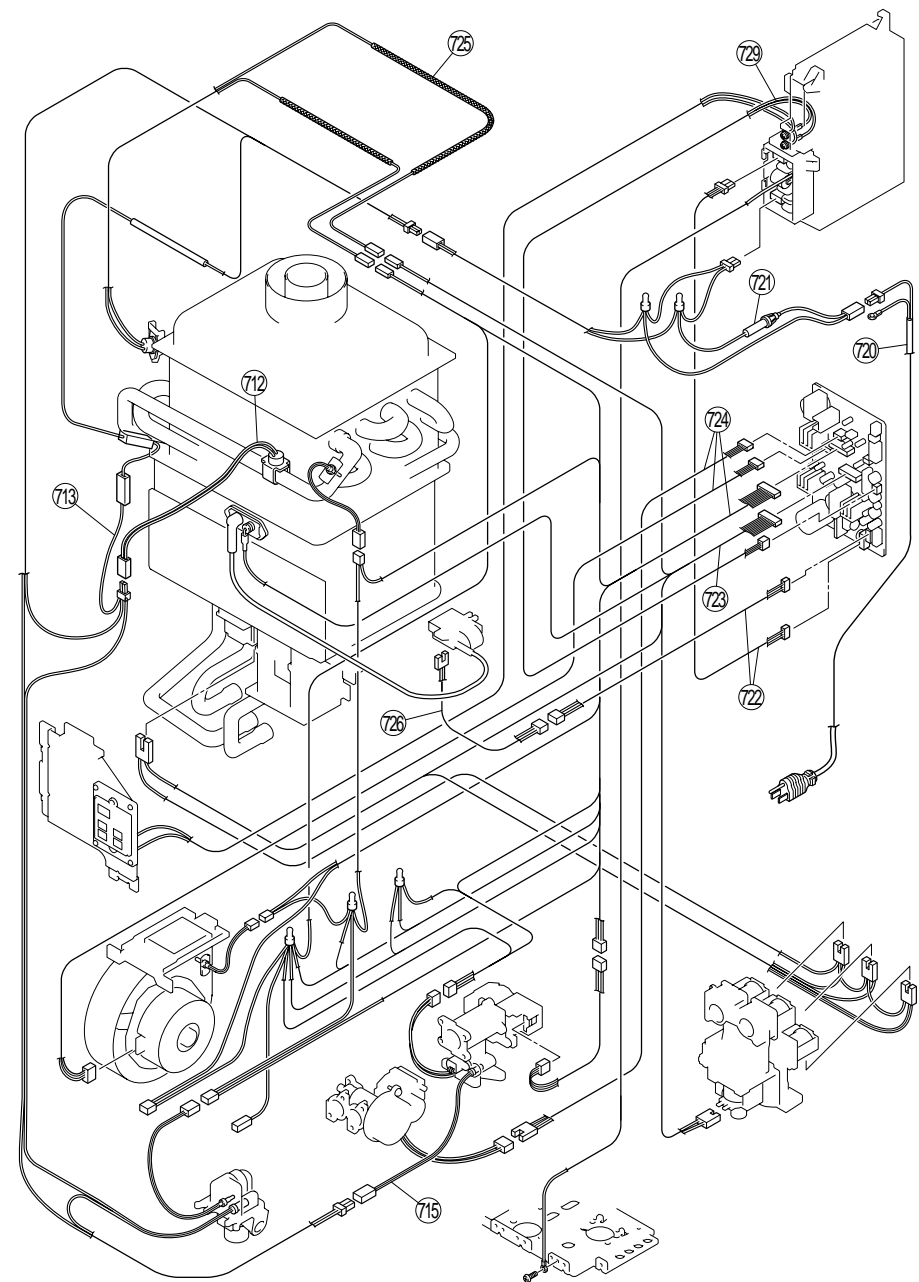

PARTS LIST

Number	Description	Parts Number	Quantity			Number	Description	Parts Number	Quantity			Number	Description	Parts Number	Quantity		
			R94LSi	R75LSi	R50LSi				R94LSi	R75LSi	R50LSi				R94LSi	R75LSi	R50LSi
001	Main Body (FF)	109000010	1	1	1	141	Joint Exhaust Tube Frame Supporter	U245-435	2	2	2	716	Antifrost Heater Clip B	CF29-742	2	2	2
002	Wall mounting bracket	109000024	2	2	2	142	Air Inlet Box Cover	U245-419	1	1	1	717	Antifrost Heater Clip A	AU111-653	1	1	1
003	Rubber Bushing	U245-125	1	1	1	143	Heat Exchanger Assembly	107000010	1	-	-	718	Antifrost Heater Clip C	AU100-721	1	1	1
004	Connection Reinforcement Panel	109000023	1	1	1	143	Heat Exchanger Assembly	107000011	-	1	1	719	Inlet Air Thermistor	105000029	1	1	1
005	Heat Protection Plate	U245-107	1	1	1	144	Flue Connection Assembly	108000015	1	1	1	720	Power Cord	CP-90580	1	1	1
006	Front Panel	109000012	1	1	1	144	Flue Connection Assembly-Male (optional)	108000016	1	1	1	721	Fuse Harness(FF)	105000031	1	1	1
008	Front Panel Gasket-1	U245-3185-1	2	2	2	145	O-ring	108000017	1	1	1	722	Power Harness	105000033	1	1	1
009	Remote Controller Ass'y	MC-91-1US-S-FLVA	1	1	1	146	O-ring	108000018	1	1	1	723	Solenoid Valve Harness	105000034	1	1	1
010	Remote Controller Bracket	103000011	1	1	1	147	Pipe Seal	108000019	1	1	1	724	Sensor Harness	105000035	1	-	-
011	Side Cover	U245-3121X05	2	2	2	148	Cap	108000020	1	1	1	724	Sensor Harness	105000036	-	1	1
012	Side Cover Rid	U245-3122X02	4	4	4	400	Water Inlet (3/4" NPT)	H73-501-2	1	1	1	725	Thermal Fuse Harnes Assembly	105000039	1	1	1
014	Rubber Bushing	CF79-41020-A	1	1	1	401	Water Flow Servo & Sensor Assembly	107000014	1	-	-	726	Ignitor Harness	105000040	1	1	1
016	Packing	AU105-113	1	1	1	401	Water Flow Servo & Sensor Assembly	107000015	-	1	1	727	Flow Sensor	105000041	1	1	1
017	Side Cover Assy	109000022	2	2	2	402	Rectifier	M8D1-15X01	1	1	1	729	Remote Controller Harness	105000042	1	1	1
100	Gas Control Assembly	106000010	1	1	1	403	By-pass Servo Assembly	M6J-1-4	1	-	-	730	Thermistor	H111-650	1	1	1
101	Test Port Set Screw	AU39-965X01	2	2	2	404	Stop Bracket	AH69-310	2	-	-	800	Screw	ZIHD0510UK	8	8	8
102	Gas Connection (3/4" NPT)	CU195-1866	1	1	1	404	Stop Bracket	AU195-321X01	-	1	1	801	Screw	CP-30580	4	4	4
103	Burner Unit Assembly (LPG)	106000011	1	1	1	405	Plug Band	109000018	1	1	1	802	Resin Washer	CF83-41430	4	4	4
103	Burner Unit Assembly (NG)	106000012	1	1	1	408	Hot Water Outlet (3/4" NPT)	U245-865-3	1	1	1	803	Screw	108000021	3	3	3
110	Manifold Assembly (LPG)	106000013	1	1	1	409	Stop Bracket	AU162-1876X01	1	1	1	804	Thermistor Stop Screw	U217-449	1	1	1
110	Manifold Assembly (FF-NG)	106000014	1	1	1	410	Plug Band (small)	AU195-321X01	1	1	1	805	Screw	ZAA0408UK	3	2	2
113	Pressure Point Sealing Screw	C10D-5	1	1	1	411	Drain Valve	AU142-444	1	1	1	810	O-ring	M10B-2-4	2	2	2
114	Combustion Chamber Sightglass Plate	106000016	1	1	1	412	Water Filter Assembly	H98-510-S	1	1	1	811	O-ring	M10B-2-3	1	1	1
116	Electrode	H73-120	1	1	1	413	Cover	109000020	1	1	1	812	O-ring	M10B-13-4	1	1	1
117	Flame Rod	105000010	1	1	1	700	PCB	105000011	1	-	-	813	O-ring	M10B-2-18	2	1	1
118	Electrode Packing	AH66-398X01	1	1	1	700	PCB	105000012	-	1	1	814	O-ring	M10B-2-16	2	2	2
119	Electrode Holder	AH66-393	1	1	1	701	Surge Protector	U250-1602-2X01	1	1	1	815	O-ring	M10B-2-14	2	1	1
121	Tube Joint	U242-312	1	1	1	701	Surge Protector with terminal (optional)	BU195-1873-2	1	1	1	816	O-ring	M10B-2-7	1	1	1
122	Vent Tube	AU161-665-CX01	1	1	1	702	PCB Cover-side	105000015	1	1	1	817	O-ring	M10B-1-24	1	1	1
125	Fan Motor All Assembly	108000010	1	1	1	703	PCB Cover-front	105000017	1	1	1	818	Packing	C36E1-6	2	2	2
131	Rubber Boot Bracket Right	U245-566	1	1	1	706	Ignitor	EI-144	1	1	1	819	Screw	ZAG0512UK	2	2	2
132	Combustion Chamber Fan Bracket	U245-255X01	1	1	1	707	High Tension Cord	105000019	1	1	1	820	Screw	ZQAA0514UK	4	4	4
135	Air Inlet Box All Assembly	108000013	1	1	1	708	Electrode Sleeve	AU206-218	1	1	1	821	Screw	ZQAA0508UK	2	2	2
136	Rubber Boot Bracket Left	U245-408	1	1	1	709	Thermistor	105000020	1	1	1	822	Screw	ZBA0512UK	3	3	3
137	Rubber Boot	U245-409X01	1	1	1	710	Thermistor Clip Large	CP-90172	1	1	1	888	Manual	100000011	1	1	1
138	Rubber Boot Clamping Ring	U245-567	1	1	1	711	Thermal Fuse Clip	U217-676X02	5	5	5	889	Tech Sheet	100000013	1	1	1
139	Air Inlet Duct	108000014	1	1	1	712	Frost Sensing Switch	U242-511	1	1	1	900	Front Panel Label (94)	100000014	1	-	-
140	AirInlet Box Frame	U245-434X02	1	1	1	713	Anti Frost Heater (120V)	105000022	1	1	1	900	Front Panel Label (75)	100000015	-	1	-
						715	Valve Heater (120V) Assembly	105000024	1	1	1	900	Front Panel Label (50)	100000017	-	-	1