

INSTALLER'S & OWNER'S MANUAL

HVAC INSTALLER: PLEASE LEAVE MANUAL FOR HOMEOWNER

Ultra·Aire™ 65H



- **Energy Star efficient**
- **High capacity effective dehumidification:
up to 65 pints of water a day**
- **MERV-11 filtration standard; MERV-14 optional**
- **Compact design**
- **5 year warranty**

P/N 4027170 • Serial No. _____ Install Date: _____

Sold by:



Driven by performance. Powered by design.™

P.O. Box 8680 Madison, WI 53708 • TOLL-FREE 1-800-533-7533 • www.thermastor.com • sales@thermastor.com

TS-422c

TABLE OF CONTENTS

Introduction	3	4.9A Setting the Time	8
Features & Benefits	3	4.9B Ventilation Schedule	8
Safety Precautions	3	4.9C Automatic or Manual Mode	8
1. Intended Application	3	5. Control Package Diagram Sheet.....	9
2. Registrations	3	6. Maintenance	10
3. Specifications	3	6.1 High Efficiency Air Filter	10
4 . Installation	3	6.2 Optional Fresh Air Intake	10
4.1 Installation Checklist	3	7. Wiring Diagrams	11
4.1A Power Accessibility	3	8. Optional Parts List	12
4.1B Space	4	9. Service Parts List	13
4.1C Low Voltage Wiring	4	Routine Maintenance	13
4.1D Back-Draft Damper	4	10. Service	14
4.1E Support Structure and Suspension	4	10.1 Technical Description	14
4.2 Electrical Requirements	4	10.2 Troubleshooting	14
4.3 Condensate Removal	4	10.3 Refrigerant Charging	15
4.3A Lifting Condensate	4	10.4 Compressor/Capacitor Replacement	15
4.3B Condensate Pump Kit	4	10.5 Electric Ventilation Damper	15
4.4 Ducting	5	10.6 Condensate Pump Kit	15
4.4A Fresh Air/Supply Air	5	DEH 3000/DEH 3000R Digital Controller	16
4.4B Ducting for Fresh Air - Option	6	Warranty	17
4.4C Installation in a Basement or Crawlspace	6		
4.4D Installation in an Attic	6		
4.4E Installation in a Structure with No Forced Air HVAC System.....	6		
4.4F Ducting for High Efficiency Filtration	6		
4.5 Compressor Release and Noise Abatement	6		
4.6 Controls	6		
4.6A Humidity/Fan Control Panel WITHOUT Fresh Air Ventilation or Damper	7		
4.6B Humidity/Fan Control Panel WITH Fresh Air Ventilation and WITHOUT Damper	7		
4.6C Humidity/Fan Control Panel WITH Fresh Air Ventilation AND Damper	7		
4.6D Ventilation Timer and Humidity Control WITH Fresh Air AND Motorized Damper	7		
4.6E DEH 3000 Digital Controller WITH Fresh Air AND Damper	7		
4.6F DEH 3000 Digital Controller WITHOUT Fresh Air	7		
4.7 Humidity Control Adjustment	7		
4.8 Fan/Filter Switch	7		
4.9 Ventilation Timer	7		

SAFETY PRECAUTIONS

Read the installation, operation and maintenance instructions carefully before installing and operating this device. Proper adherence to these instructions is essential to obtain maximum benefit from your Ultra-Aire 65H indoor air quality system.

READ AND SAVE THESE INSTRUCTIONS

- The device is designed to be installed INDOORS IN A SPACE THAT IS PROTECTED FROM RAIN AND FLOODING.
- Install the unit with space to access the front panel for maintenance and service. DO NOT INSTALL UNIT WITH THE FRONT PANEL INACCESSIBLE.
- Avoid directing the discharge air at people, or over the water in pool areas.
- If used near a water source; be certain there is no chance the unit could fall into the water or get wet. The unit should also be plugged into a GFCI (Ground Fault Circuit Interrupt outlet).
- DO NOT use the device as a bench or table.
- DO NOT place the device directly on structural members.
- A drain pan MUST be placed under the unit if installed above a living area or above an area where water leakage could cause damage (see local regularity code for more information).

Read and Save These Instructions

 **WARNING!** — This symbol indicates important instructions. Failure to heed them can result in serious injury or death.

 **CAUTION!** — This symbol indicates important instructions. Failure to heed them can result in injury or material property damage.

1. Intended Application for Ultra-Aire 65H

For the ideal installation, draw air from the central part of the home and return it to isolated areas of the home like the bedrooms, den, utility room, or family room. The ductwork of the existing heating system can be used to supply air to the home.

2. Registrations

The Ultra-Aire 65H conforms to UL STD 474 and CSA Standard C22.2 No.92.

3. Specifications

Part Number:	4027170
Blower:	190 CFM @ 0.0" WG
Power:	680 Watts @ 80°F and 60% RH
Supply Voltage:	110-120 VAC – 1phase – 60 Hz
Current Draw:	5.50 Amps
Energy Factor:	2.0 L/kWh
Operating Temp.:	Between 40°F and 90°F Max
Sized for:	Up to 1600 Sq. Ft. - Typical
Minimum Performance at 80°F and 60% RH	
Water Removal:	65 pints/day
Efficiency:	4.3 Pints/kWh
Air Filter:	MERV-11
Efficiency:	Standard 65% Efficient ASHRAE Dust Spot Test
Size:	9" x 11" x 1"
Power Cord:	9', 110-120 VAC, Ground
Drain Connection:	3/4" Threaded MPT
Drain Hose:	5/8" ID x 8'

Dimensions	Unit	Shipping
Width:	21"	27"
Height:	12"	17"
Depth:	12"	17"
Weight:	55 lbs	59 lbs

4. Installation

4.1 Installation Checklist

CAUTION

Prior to installation of the Ultra-Aire 65H, the following checklist should be reviewed. The Ultra-Aire 65H can be installed in a variety of locations to meet the owner's needs, and be integrated with existing forced air systems or existing ductwork if desired. The location choice is contingent on a variety of requirements not limited to: ease of service, controls access, drainage, filtration, power, fresh-air ventilation (optional), water damage prevention, and current regulatory codes (ASHRAE, fire, etc). Please address all of these issues before you select the location of the device.

■ 4.1A Power Accessibility

Unit should be located in an area where the cord's length (8') should easily reach a 110-120 VAC electrical outlet with a minimum of a 15 A circuit capacity.

FOR HVAC INSTALLER ONLY

■ 4.1B Space

Location should have enough clearance to handle the unit's overall dimensions as well as the necessary return/supply ductwork to the unit.

■ 4.1C Low Voltage Wiring

Unit location should be in an area where field wiring the remote controls (low voltage) to the unit will be possible.

■ 4.1D Back-Draft Damper (P/N 4023647)

It is recommended that a back draft damper be used in the discharge duct of the Ultra-Aire 65H, especially when connecting to the supply ducting system. The backdraft damper prevents supply air from counter flowing through the Ultra-Aire 65H when it is not operating. The unit location should be chosen to allow installation of this accessory.

■ 4.1E Support Structure and Suspension

Place the Ultra-Aire 65H on supports to raise the base of the unit. Do not place the Ultra-Aire 65H directly on structural building members without vibration absorbers or unwanted noise may result.

The Ultra-Aire 65H may be suspended with a hang kit (4028111) or a suitable alternative from structural members, as long as the suspending assembly supports the Ultra-Aire 65H's base in its entirety. Do not hang the Ultra-Aire 65H from the cabinet. Remember to place a drain pan under the unit if it is suspended above a finished area or above an area where water leakage could cause damage.



Hang Kit (4028111) shown suspending a UA65H. Available from your dealer or Therma-Stor. Call 1-800-533-7533.

4.2 Electrical Requirements

⚠ WARNING!

WARNING: DO NOT ALLOW THE YELLOW LEAD FROM THE ULTRA-AIRE TO CONTACT THE RED LEAD FROM THE ULTRA-AIRE OR DAMAGE TO THE TRANSFORMER WILL RESULT.

The Ultra-Aire 65H plugs into a common grounded 115VAC outlet. The device draws 5.5 Amps under normal operating conditions. If used in an area which may become wet, a ground fault interrupter (GFI) protected circuit is recommended. Please, consult local electrical codes for any further information.

Therma-Stor LLC offers a family of control devices for use with the Ultra-Aire 65H. The controls are to be located remotely from the unit and located in the space to be conditioned. The controls are low voltage (24 volt) and should be connected to the Ultra-Aire 65H with low voltage wire (thermostat or other appropriate).

⚠ CAUTION

Do not install the control panel where it may not accurately sense the relative humidity such as near HVAC supply registers, near exterior doors, on an outside wall, near a window, or near a water source.

The installer must supply the wiring between the Ultra-Aire 65H and the control panel. Be sure to safely route the control wiring to prevent damage during installation.

⚠ CAUTION

Do not cross wires when connecting the Ultra-Aire 65H and the remote control panel or damage to the transformer may result. The remote controls of the Ultra-Aire 65H are powered by a low voltage circuit (24VAC) and must NEVER contact or be connected to a high voltage circuit.

The control wires leaving the Ultra-Aire 65H and the remote control panels are numbered and color-coded to prevent confusion. Some of the control wires leaving the Ultra-Aire 65H may not be used with certain control panels and should be left unconnected with wire nuts taped onto the stripped ends for safety. Be sure to consult the electrical schematic in this manual or inside the access panel of the Ultra-Aire 65H before making control connections.

4.3 Condensate (Water) Removal

⚠ CAUTION

A trap in the drain line is preferred, but not required for the unit to drain properly. Local codes may require a trap. Use care to keep the pipe assembly as flat to the floor as possible. Kinks and/or humps will prevent proper drainage.

FOR HVAC INSTALLER ONLY

The Ultra-Aire 65H generates condensate. Install a 3/4" male nominal pipe thread adapter to the drain pan. It is necessary to assemble your own drain pipe assembly utilizing 3/4" PVC pipe to get the condensate to a floor or other drain. Pipe is commonly available in 10' lengths from building supply, plumbing or hardware stores. Grade of pitch should be 1" per 10'.

4.3A Lifting Condensate

A condensate pump may be installed if lift is required to dispose of the condensate.

4.3B Condensate Pump Kit (4028085)

A condensate pump kit is available from the factory for use with the Ultra-Aire 65H and provides 15' of lift. Condensate is automatically pumped to a remote location when the water level in the pump's reservoir rises to close the float switch. The pump also contains a safety float switch. The white leads from this switch extend from beneath the pump cover. This switch should be installed in series with the field wire that connects the blue (#5) lead from the Ultra-Aire 65H to the control panel. If the pump fails, this switch opens the compressor control circuit and stops water production before the reservoir overflows. The Ultra-Aire 65H will continue to ventilate or circulate air as normal, but will not dehumidify until this switch closes.

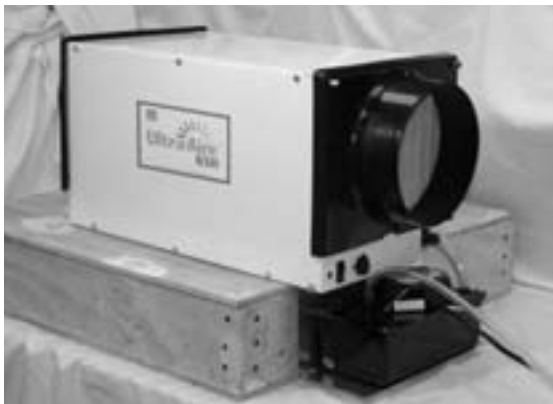

Condensate Pump Kit (4028085) shown installed. Available from your dealer or Therma-Stor. Call 1-800-533-7533.

4.4 Ducting

⚠ CAUTION

Replacing the filter requires the return duct to be removed. Failure to use flex duct will prevent filter access. Three feet of flex duct should be adequate to access the filter.

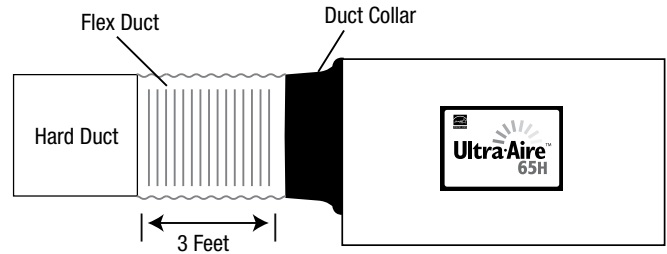

For the ideal installation, draw air from the central part of the home and return it to the isolated areas of the home like the bedrooms, den, utility room, or family room. The ductwork of the existing heating system can be used to supply air to the home. If the existing supply goes to isolated areas of the home, discharge the supply of the Ultra-Aire 65H into the supply of the existing heating system. Installation of a separate supply duct to the Ultra-Aire 65H from a central area is recommended.

4.4A Supply Air

⚠ CAUTION

DO NOT draw air directly from the kitchen, laundry, or isolated basement.

You may draw air from a basement that is open to the home. All flexible ducting connected to the Ultra-Aire 65H should be UL listed.

A short piece of flexible ducting on all Ultra-Aire 65H duct connections is recommended to reduce noise and vibration transmitted to rigid ductwork in the structure. Ducting the Ultra-Aire 65H as mentioned requires consideration of the following points:

Duct Sizing: For total duct lengths up to 25', use a minimum 8" diameter round or equivalent rectangular. For longer lengths, use a minimum 10" diameter or equivalent. Grills or diffusers on the duct ends must not excessively restrict airflow.

Connecting to existing HVAC systems: An optional 8" check backdraft damper is available from the factory to prevent reverse air flow through the Ultra-Aire 65H. If the Ultra-Aire 65H is ducted to the supply of an air handler, the check damper should be placed in the Ultra-Aire 65H supply duct.

⚠ CAUTION

Contact the factory when connecting to a static pressure of greater than or equal to +.5" WG.

FOR HVAC INSTALLER ONLY

4.4B Ducting for Fresh Air — Option

Fresh air may be brought into the structure by connecting an insulated duct from outside the structure to the 6" inlet of the Ultra-Aire 65H. Advantages of this form of ventilation include:

1. Outside air is filtered before entering the building.
2. Outside air will be dehumidified before entering if the Ultra-Aire 65H is running in dehumidification mode.
3. Drawing air from outside and blowing inside aids in slightly pressurizing the structure. This helps prevent dirty and humid air from entering elsewhere. It also reduces the potential for carcinogenic radon gas to enter and provides a small amount of make-up air for open combustion and exhaust devices like the clothes drier, fireplace, and water heater.
4. Exhaust fans are recommended in the bath rooms and kitchen.

In cold climates or areas where the outdoor dew point is low at times, ventilation can be used to dehumidify the structure, making the Ultra-Aire 65H capable of year-round drying. This is accomplished by bringing the dry, low dew point air into the structure during these times. This approach is often more economical than running the dehumidifier to remove excess moisture from the structure. In cold climates, adequately ventilating is critical to reduce the inside moisture content and avoid moisture accumulating in the wall cavities. TIP: if your house experiences condensation on the interior surface of the windows during the winter, increasing the amount of ventilation will often solve the problem.

An insulated 6" diameter duct is generally sufficient to provide up to 65 CFM of outside air. Large quantities of outside air will impact Ultra-Aire 65H performance positively or negatively, depending upon the inside and outside air conditions. The outside air duct should be connected to the front of the unit. With a standard tee, the amount of outside air can be restricted with a blade damper.

4.4C Installation in a Basement or Crawlspace with an Existing Forced Air HVAC System.

Basement Installation: Install a separate 8" return for the Ultra-Aire 65H in a central area of the structure. Optional: Duct the supply of the Ultra-Aire to a 8" x 8" x 8" tee/damper, adjusted to 20% open to the basement. Duct the other side of the tee to the air supply of the existing HVAC system with a backdraft damper.

Crawlspace Installation: Install a separate return for the Ultra-Aire 65H in a central area of the structure. Optional: Duct the supply of the Ultra-Aire 65H to a 8" x 8" x 8" tee/damper that is 20% open to the crawlspace if desired. Duct the other side of the tee to the air supply of the existing HVAC system with a backdraft damper.

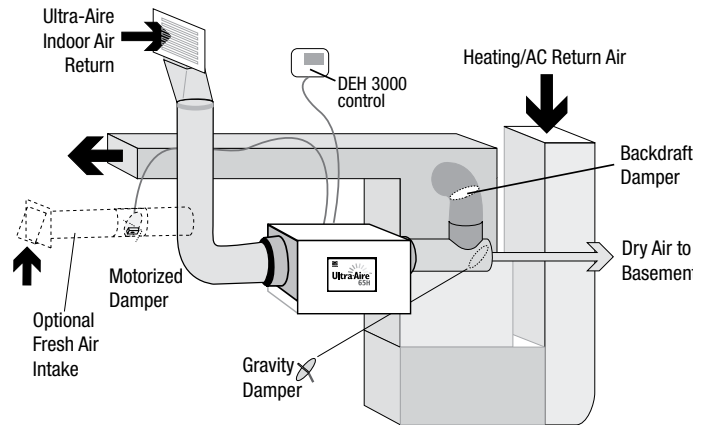

Instead of installing a separate return to the Ultra-Aire 65H, and if the existing system has multiple returns, it is possible to select one to disconnect from the existing forced air system and use it for the dedicated Ultra-Aire return. Always select a return from a central location in the structure in an area that is always open to the rest of the structure. Do not use a return from a room that may have its door closed much of the time or, alternatively, install a separate return from the open part of the house.

4.4D Installation in an Attic with an Existing Forced Air HVAC System

⚠ CAUTION

ALWAYS place a drain pan under the unit if it is suspended above a finished area or above an area where water leakage could cause damage.

The interrupt switch should be installed in series with the field wire that connects the blue (#5) lead from the Ultra-Aire 65H to the blue (#5) lead on the control panel. If overflow occurs, this switch opens the compressor control circuit and stops water production before the drain pan overflows. The Ultra-Aire 65H will continue to ventilate or circulate air as normal, but will not dehumidify until this switch closes.

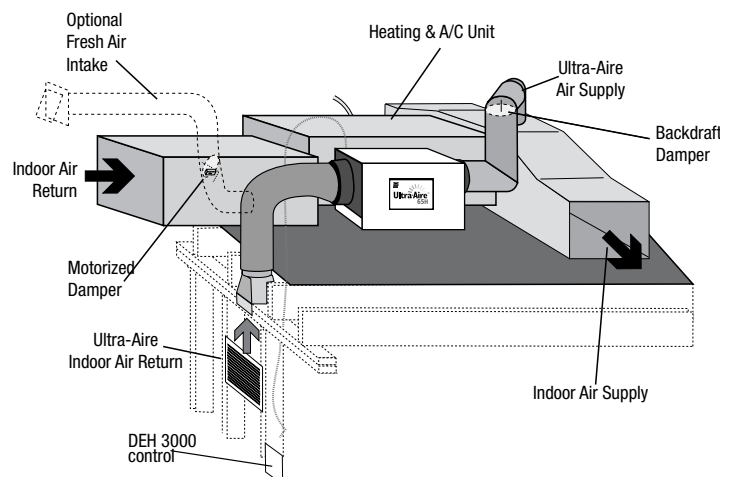

FOR HVAC INSTALLER ONLY

The preferred method of installation is to create a separate return for the Ultra-Aire 65H in a central area of the structure. Duct the supply of the Ultra-Aire 65H to the air supply of the existing HVAC system.

4.4E Installation in a Structure with No Existing Forced Air HVAC System

When installing the Ultra-Aire 65H in a structure that does not have a forced air HVAC system, a single return for the Ultra-Aire 65H should be installed in central open area of the structure. DO NOT locate the return in a bathroom or a kitchen. The supplies of the Ultra-Aire 65H should be located in the remote areas of the structure (such as bedrooms, den, etc.). By ducting this way, the air inside the structure will circulate through the Ultra-Aire 65H to be filtered and dehumidified. A 6" diameter duct is recommended for branches to the bedrooms. A 8" diameter duct is recommended for branches to larger areas.

4.4F Ducting for High Efficiency Filtration

The Ultra-Aire 65H is equipped with a high efficiency MERV 11 media filter (P/N 4027158). For optimal performance it is recommended that the filter be replaced every 3-6 months.

4.5 Noise Abatement

A length of 10 feet or more of flex ducting on the outlet of the Ultra-Aire 65H will reduce air noise from the fan. A length of flexible ducting on all Ultra-Aire 65H duct connections is recommended to reduce noise transmitted to rigid ductwork in the structure.

CAUTION

Replacing the filter requires the return duct to be removed. Failure to use flex duct will prevent filter access. Three feet of flex duct should be adequate to access the filter.

4.6 Controls

All control panels should be mounted in a central area of the structure where it can accurately sense the humidity of the air in the living space and be accessed. All controls require field wiring from the unit location to the panel mount location. **To determine how each control operates the Ultra-Aire 65H, it must first be determined which control is being used and whether or not the 90H is ducted for fresh air ventilation. Refer to appropriate section.**

Humidity/Fan Control Panel (P/N 4024155)

4.6A Humidity/Fan Control Panel WITHOUT Fresh Air Ventilation or Damper

4.6B Humidity/Fan Control Panel WITH Fresh Air Ventilation and WITHOUT Damper
4.6C Humidity/Fan Control Panel WITH Fresh Air Ventilation AND Damper

Ventilation Timer/Humidity Control Panel (P/N 4024125)

4.6D Ventilation Timer and Humidity Control WITH Fresh Air AND Motorized Damper

DEH 3000 Digital Control (P/N 4026570)

4.6E Digital Controller WITH Fresh Air AND Damper
4.6F Digital Controller WITHOUT Fresh Air

4.6A Humidity/Fan Control Panel WITHOUT Fresh Air Ventilation or Damper

The humidity/fan control panel automatically controls the humidity of the living space. The humidity/fan control panel contains an adjustable humidity control and a fan switch. The panel has a cover that must remain open to the air within the living space for accurate humidity sensing. When the fan switch is in the "ON" position, air will be continually filtered and circulated throughout the home. For humidity control operation refer to section 4.7.

4.6B Humidity/Fan Control Panel WITH Fresh Air Ventilation and WITHOUT Damper

The humidity/fan control panel automatically controls the humidity of the living space. The humidity/fan control panel contains an adjustable humidity control and a fan switch. The panel has a cover that must remain open to the air within the living space for accurate humidity sensing. Outside air is continually introduced whenever fan is "ON." Manual operation of fan filter switch controls outside air ventilation. Since the fan operates whenever the Ultra-Aire 65H is dehumidifying outside air will also be introduced. For humidity control operation refer to section 4.7.

4.6C Humidity/Fan Control Panel WITH Fresh Air Ventilation AND Damper

In this configuration, a motorized damper has been installed in the fresh air duct. When the fan/filter switch is in the "OFF" position, the damper is closed. The Ultra-Aire 65H will then circulate and dehumidify air to provide humidity control. When the fan/filter switch is in the "ON" position, the motorized damper will open and the fan will run, introducing outside air. The unit may or may not be dehumidifying in the ventilation mode, depending on the humidity control setting. See Section 4.7 for humidity control operation.

4.6D Ventilation Timer and Humidity Control WITH Fresh Air AND Motorized Damper

Refer to sections 4.7 through 4.9C.

4.6E DEH 3000 Digital Control WITH Fresh Air AND Damper

Refer to Section 5.

4.6F DEH 3000 Digital Control WITHOUT Fresh Air

Refer to Section 5.

4.7 Humidity Control Adjustment

Set the humidity control to the desired humidity level for the home. Turning the knob clockwise results in a drier setting. See the back of the control panel cover for set points. The dehumidifier will run continuously until the relative humidity (RH) is reduced to the humidity control dial setting. Settings below 45% RH are not recommended.

4.8 Fan/Filter Switch

When the switch is ON; air will be constantly filtered through the Ultra-Aire 65H and circulated throughout the house. When the switch is OFF the fan will operate only when the humidity control calls for dehumidification or when the ventilation timer calls for ventilation.

4.9 Ventilation Timer (if applicable)

The ventilation timer controls the fan and the motorized fresh air damper. When the ventilation timer is activated, the Ultra-Aire 65H will circulate the indoor air, and bring in fresh air from outside. The ventilation timer should be set as suggested by applicable codes and standards or as required by the homeowner.

The ventilation timer allows six programs with each program having one "ON" and one "OFF" event. A program allows the user to turn the ventilation on and as desired. Each of these programs can be repeated daily or weekly or during a specified block of days. All six of the programs operate independently of each other. If the timer fails to operate or operates erratically, check that the control panel receives 24Vac from the Ultra-Aire 65H. If 24Vac is present at the control panel, reset the timer by pressing the reset button at the bottom center of the timer face. The reset button is the small recessed button with an R beneath it located below the 1-7 and h buttons. Depress the reset button until the display clears. Release the button. The display will reappear as 00:00. Resetting the timer will clear the time and all program settings. After resetting the timer follow the instructions below to set the correct time and ventilation programs.

4.9A Setting the Time

Set the correct time on the timer by sliding the switch in the upper right hand corner of the timer to the clock symbol. and pressing the 1-7 (DAY), h (HOUR), and m (MINUTE) buttons. The timer operates on a 24-hour (military time) clock.

4.9B Ventilation Schedule

Slide the switch in the upper right hand corner to the program symbol "P". "ON" will appear to the right of the time and the number "1" will appear in the lower right hand corner of the display. The "1" and "ON" signify the turn on time for the first program. Press the 1-7, "h" and "m" button to choose the days of the week for this program. You can choose Mon.-Sun., Mon.-Fri., Sat.-Sun., or any single day of the week. The days chosen are shown along the top of the display on the ventilation timer. Next press the "h" button to set the hour for the start of the ventilation period. Press the "m" button to set the minutes past the hour to start the ventilation. The timer operates on a 24-hour clock (military time).

Once the ventilation start time is set; press the "I/O" button. The word "OFF" should appear to the right of the time and the number "1" should remain in the lower right hand corner of the display. The "1" and "OFF" signify the turn off time for the first program. Set the turn off time using the 1-7, "h" and "m" buttons in the same way as described above and continue through the sixth programs. When setting the ventilation programs, you can return to the current time display by sliding the switch in the upper right corner of the timer to "RUN". The slide switch must be set to "RUN" for the timer to operate its scheduled programs.

4.9C Automatic or Manual Mode

The slide switch in the upper left of the timer is used to choose between automatic and manual operation. When the slide switch is set to AUTO mode, the Ultra-Aire 65H will ventilate when the scheduled programs call for ventilation. When the slide switch is set to manual (set to hand symbol on the right), the operation of the timer is controlled by the I/O button only. Pressing the I/O button will switch the ventilation timer between ON (detent) and OFF (detent). As you press the I/O button, "ON" or "OFF" will be displayed to the right of the time. The "ON" or "OFF" indicates if the ventilation timer is on or off. The I/O button will manually override scheduled programs if the timer is in AUTO mode.

ATTENTION INSTALLER

5 Control Package Diagram Sheet: WIRE THE UNIT AND CONTROL PACKAGE AS SHOWN IN THE DIAGRAM BELOW

Humidity/Fan Control Panel

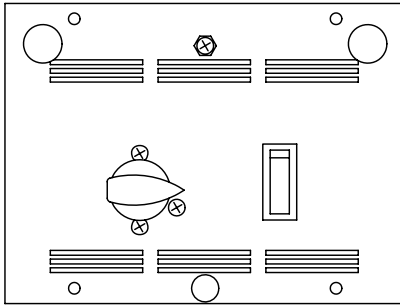

Control Part No. 4024155

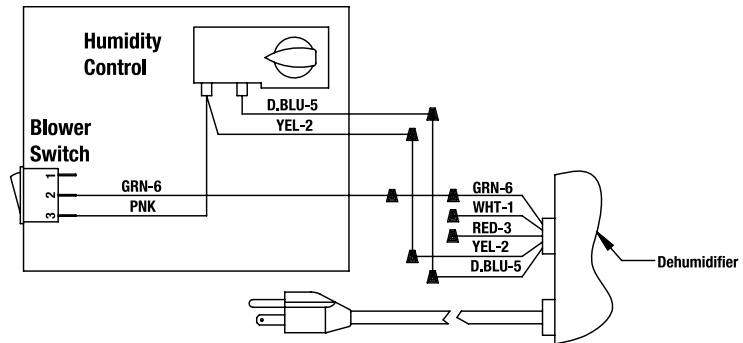

Ventilation Timer/ Humidity Control Panel

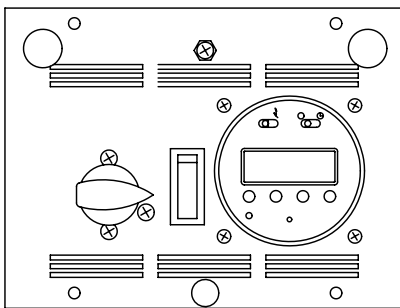

Control Part No. 4024125

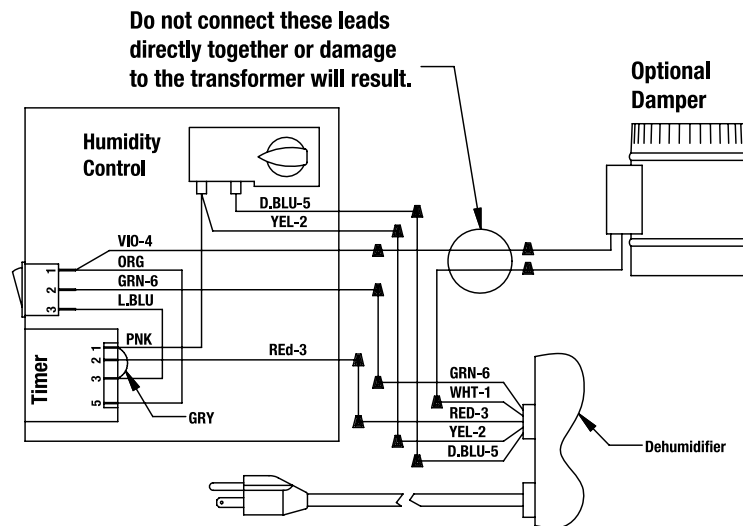

DEH 3000 Digital Control



(P/N 4028539; with remote: P/N 4028407)

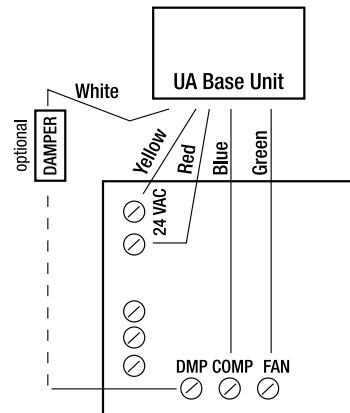

WARNING: DO NOT allow the yellow lead from the unit to contact the red lead or the white lead from the unit or damage to the transformers will result. Do not direct connect the white lead on the unit to the violet lead on the ventilation control or damage to the transformer will result.

6. Maintenance

6.1 High Efficiency Air Filter

The Ultra-Aire 65H is equipped with a MERV 11 media filter. This filter should be checked every three months. Operating the unit with a dirty filter will reduce dehumidifier capacity and efficiency and may cause the compressor to cycle off and on unnecessarily on the defrost control.

DO NOT operate the unit without a filter or with a less effective filter. Operating the unit without a filter or with a less effective filter may cause internal damage to the unit and invalidate the product warranty.

6.2 Optional Fresh Air Intake

Check and clean the screen on the outdoor fresh air intake port seasonally. The screen may become plugged during the seasons when there are many particles in the outdoor air.

Notes:

Ultra-Aire 65H WIRING DIAGRAM

7. Wiring Diagram

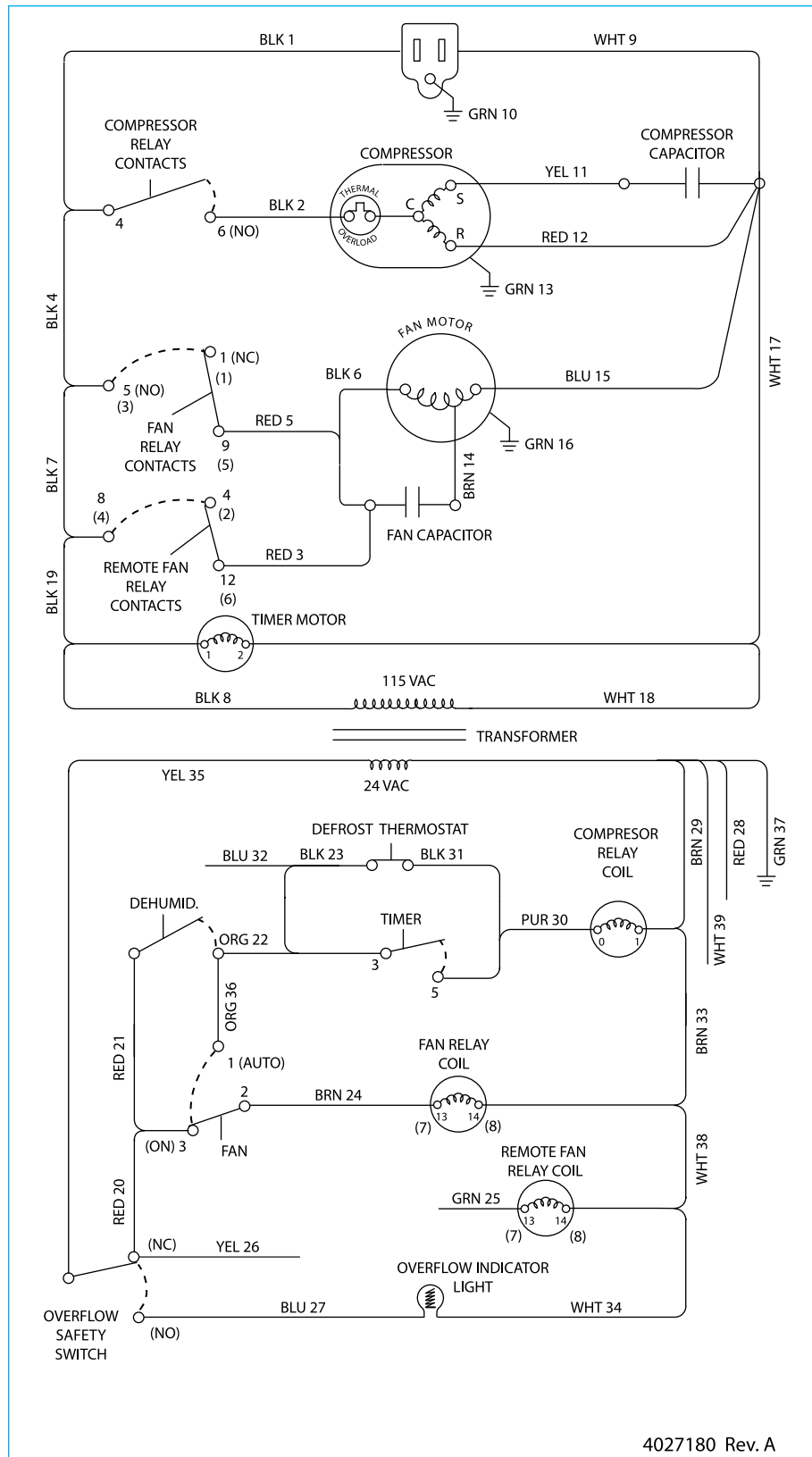

8. Optional Parts List: Ultra-Aire 65H Indoor Air Quality System

Part No.	Description
4024125	Control Panel Assembly, Ventilation Timer & Humidity Control
4024155	Control Panel Assembly, Humidity/Fan
4027158	Filter MERV 11
4028085	Pump Kit
4028111	Hang Kit
4023647	8" Gravity Damper
4020646	8" Butterfly Damper
4027415	8" Flex Duct
4020177	8" Flex Duct (insulated)
4027430	Register Head 8"
4020126	Register Grill (White)

DEH 3000 Digital Control
(P/N 4028539; with remote: P/N 4028407)



Control Panel Assembly, Ventilation Timer & Humidity Control (P/N 4024125)



Control Panel Assembly, Humidity/Fan (P/N 4024155)

FOR HVAC INSTALLER ONLY

9. Service Parts List: Ultra-Aire 65H Indoor Air Quality System

Part No.	Description
4026703	Compressor
4026755	Compressor Overload
4027162	Compressor Relay
4027165	Run Capacitor
4027035	Coil Set
4027169	Impeller Fan
4020924	Fan Relay
4027164	Fan Capacitor
4027167	Defrost Thermostat
4027166	Defrost Timer
4027149	Indicator Light
4027151	Overflow Switch
4027161	Transformer

FOR HOMEOWNER - ROUTINE MAINTENANCE

Part No.	Description
4027158	Air Filter MERV 11
4027422	4 Pack
4027427	12 Pack

The Ultra-Aire 65H is equipped with a MERV 11 media filter. This filter should be checked every three months. Operating the unit with a dirty filter will reduce dehumidifier capacity and efficiency and may cause the compressor to cycle off and on unnecessarily on the defrost control.

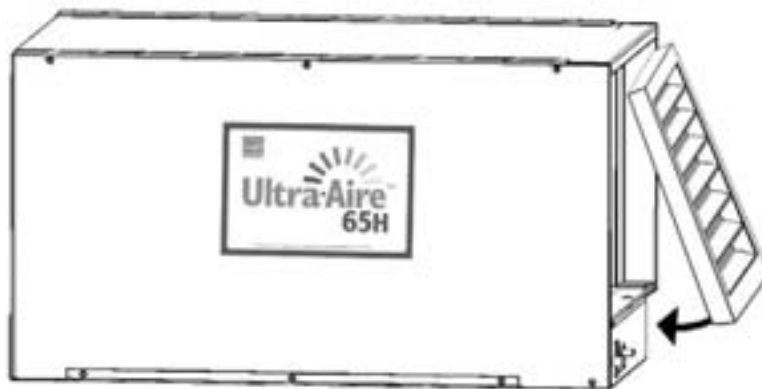

When installing a new filter, insert top first then rotate bottom into place.

10. Service

CAUTION

CAUTION: Servicing the Ultra-Aire 65H with its high pressure refrigerant system and high voltage circuitry presents a health hazard which could result in death, serious bodily injury, and/or property damage. Please contact your HVAC professional.

10.1 Technical Description

The Ultra-Aire 65H uses a refrigeration system similar to an air conditioner's to remove heat and moisture from incoming air, and add heat to the air that is discharged. Hot, high-pressure refrigerant gas is routed from the compressor to the condenser coil (See Figure 1). The refrigerant is cooled and condensed by giving up its heat to the air that is about to be discharged from the unit. The refrigerant liquid then passes through a strainer and capillary tubing which causes the refrigerant pressure and temperature to drop. It next enters the evaporator coil where it absorbs heat from the incoming air and evaporates. The evaporator operates in a flooded condition, which means that all the evaporator tubes contain liquid refrigerant during normal operation. A flooded evaporator should maintain nearly constant pressure and

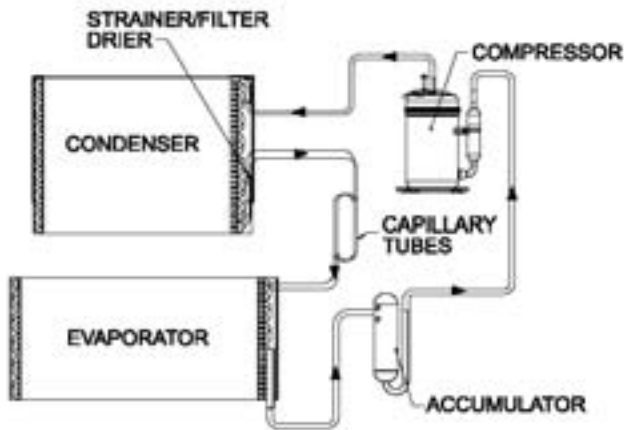

Refrigeration System of Ultra-Aire 65H

temperature across the entire coil, from inlet to outlet.

The mixture of gas and liquid refrigerant enter the accumulator after leaving the evaporator coil. The accumulator prevents any liquid refrigerant from reaching the compressor. The compressor evacuates the cool refrigerant gas from the accumulator and compresses it to a high pressure and temperature

10.2 Troubleshooting

No dehumidification, neither fan nor compressor run with fan switch and ventilation timer OFF.

1. Unit unplugged or no power to outlet.
2. Humidity control set too high or defective.
3. Loose connection in internal or control wiring.
4. Defective Compressor relay.
5. Defective control transformer.
6. Optional Condensate Pump Safety Switch open.

No dehumidification, compressor does not run but fan runs with fan switch and ventilation timer OFF and humidity control turned to ON.

1. Defective compressor run capacitor.
2. Bad connection in compressor circuit.
3. Defective compressor overload.
4. Defective compressor.
5. Defrost thermostat open.
6. Optional Condensate Pump Safety Switch open.

Fan runs with fan switch and ventilation timer OFF, but compressor cycles on and off.

1. Low ambient temperature and/or humidity causing unit to cycle through defrost mode.
2. Defective compressor overload.
3. Defective compressor.
4. Defrost thermostat defective.
5. Dirty air filter(s) or airflow restricted.
6. Low refrigerant charge, causing defrost control to cycle.
7. Bad connection in compressor circuit. Fan does not run with fan switch in either position.

Fan does not run with ventilation timer activated.

Compressor runs briefly but cycles on & off with humidity control turned to ON.

1. Loose connection in fan circuit.
2. Obstruction prevents fan rotation.
3. Defective fan.
4. Defective fan relay.
5. Defective fan capacitor.

Fan runs with fan switch ON. Fan does not run with ventilation timer activated.

1. Defective ventilation timer.
2. Time not correct on ventilation timer.
3. Ventilation timer set to manual and switched OFF.
4. Defective fan switch.

Evaporator coil frosted continuously, low dehumidifying capacity.

1. Defrost thermostat loose or defective.
2. Low refrigerant charge.
3. Dirty air filter(s) or airflow restricted.
4. Excessively restrictive ducting connected to unit.

Unit not providing ventilation. Ventilation timer not operating correctly.

1. If timer is not functioning correctly reset timer and reprogram.
2. Check control wire connections (check connections at fresh air damper also).
3. Defective fresh air damper.
4. Defective fan switch.

Unit removes some water, but not as much as expected.

1. Air temperature and/or humidity have dropped.
2. Humidity meter and or thermometer used are out of calibration.
3. Unit has entered defrost cycle.
4. Air filter dirty.
5. Defective defrost thermostat.
6. Low refrigerant charge.
7. Air leak such as loose cover or ducting leaks.
8. Defective compressor.
9. Restrictive ducting.
10. Optional Condensate Pump Safety Switch open.

Unit Test to determine problem:

1. Detach field control wiring connections from main unit.
2. Connect the yellow and green pigtails from the main unit together; only the fan should run. Disconnect the wires.
3. Connect the yellow and blue pigtails from the main unit together; the compressor and fan should run.
4. If these tests work, the main unit is working properly. You should check the control panel and field control wiring for problems next.
5. Remove the control panel from the mounting box and detach it from the field installed control wiring. Connect the blue, yellow, and green wires from the control panel directly to the corresponding colored pigtails on the main unit. Leave the violet, white and red wires disconnected!
6. Turn on the fan switch; the fan should run. Turn off the fan switch.
7. Turn on the humidity control; the compressor and fan should run.
8. If these tests work, the problem is most likely in the field control wiring.

10.3 Refrigerant Charging

If the refrigerant charge is lost due to service or a leak, a new charge must be accurately weighed in. If any of the old charge is left in the system, it must be recovered before weighing in the new charge. Refer to the unit nameplate for the correct charge weight and refrigerant type.

10.4 Compressor/Capacitor Replacement

This compressor is equipped with a two terminal external overload and a run capacitor, but no start capacitor or relay.

CAUTION

CAUTION-ELECTRICAL SHOCK HAZARD: Electrical power must be present to perform some tests. These tests should be performed by a qualified service person.

10.5 Electric Ventilation Damper

The electric ventilation damper is controlled by the ventilation timer. The damper will open when the ventilation timer is activated to allow fresh air into the structure through the fresh air inlet duct. The electric ventilation damper will remain closed when the ventilation timer is not activated to prevent over-ventilating the structure when the unit is dehumidifying or recirculating the indoor air. The electric ventilation timer operates on 24 Vac from the control circuit. DO NOT connect high voltage to the damper motor or damage to the motor may result. DO NOT force the blade of the damper by hand or damage to the damper motor may result.

The damper opens in one direction only. The damper rotates very slowly, allow sufficient time for the damper to cycle. The damper will take approximately one minute to cycle from closed to open or from open to closed.

If the electric ventilation damper fails to operate:

1. Check that the wiring is correct and that voltage is present at the damper motor.
2. Check for any obstruction inside the damper. If the electric ventilation damper fails to operate after performing these checks, it must be replaced.



Ultra-Aire™

DEH 3000R

Part No. 4028539

Part No. 4028407



5. Optional Dehumidifier & Ventilation System Controller

When used with Ultra-Aire Whole House Ventilating Dehumidifiers, the DEH 3000/3000R allows homeowners the ability to monitor and control relative humidity levels in their home.

DEH3000 P/N:	4028539
DEH3000R (remote) P/N:	4028407
Model:	DEH 3000 DEH 3000R (remote)
Operating Voltage:	24 VAC
Max Current DMP, COMP, FAN:	1 AMP each
Humidity Range/Accuracy:	10 – 95% RH, ± 5%
Auxillary Relay Capacity:	5 Amps, 24VAC
Temp Range/Accuracy:	30°-90°F, 2%
Size:	4.95"L x 1.06"W x 4.19"H

Major Operations

- Digital control of Relative Humidity (Digital Set-Point)
- Fan/Filter Operation
- Programmable Ventilation Timer
- Large, easy-to-read backlit LCD display
- Easy interaction with air handler fan (Interlock/Lockout)
- High Temperature Cut-Out
- Dryout Cycle Timer
- Auto Reboot
- Remote Sensor (DEH 3000R Only)

**To order call Therma-Stor at
1-800-533-7533**



Ultra-Aire™ Limited Warranty 65H

Limited Warranty. Therma-Stor, LLC (“Therma-Stor”) warrants as follows: (i) the Ultra-Aire 65H dehumidifier (“Product”) will be free of material defects in workmanship or materials for a period of one (1) year (“One-Year Warranty”) following the date of initial purchase of such Product by an original customer purchasing from Therma-Stor or an authorized reseller (“Customer”); and (ii) the Product’s condenser, evaporator, and compressor will be free of material defects in workmanship or materials for a period of five (5) years following the date of initial purchase of such Product by a Customer.

Limitation of Remedies. CUSTOMER’S SOLE AND EXCLUSIVE REMEDY UNDER THE ABOVE LIMITED WARRANTY AND THERMA-STOR’S ENTIRE LIABILITY THEREUNDER, SHALL BE, AT THE SOLE OPTION OF THERMA-STOR, REPLACEMENT OR REPAIR OF SUCH PRODUCT OR ITS COMPONENTS (“COMPONENTS”) BY THERMA-STOR OR THERMA-STOR’S AGENTS ONLY. REFRIGERANT, PIPING, SUPPLIES, TRANSPORTATION COSTS, LABOR COSTS INCURRED IN REPAIR OR REPLACEMENT OF SUCH COMPONENTS ARE NOT INCLUDED. THIS DISCLAIMER AND EXCLUSION SHALL APPLY EVEN IF THE EXPRESS WARRANTY AND LIMITED REMEDY SET FORTH HEREIN FAILS OF ITS ESSENTIAL PURPOSE. CUSTOMER ACKNOWLEDGES THAT NO REPRESENTATIVE OF THERMA-STOR OR OF ITS AFFILIATES OR RESELLERS IS AUTHORIZED TO MAKE ANY REPRESENTATION OR WARRANTY ON BEHALF OF THERMA-STOR OR ANY OF ITS AFFILIATES OR RESELLERS THAT IS NOT IN THIS AGREEMENT. Notwithstanding the above, during the term of the One-Year Warranty only, Therma-Stor will provide, free of charge to Customer, all Components and labor (except costs related to removal and installation of Product) required to fulfill its obligations under such One-Year Warranty.

Disclaimer of Warranties. EXCEPT FOR ABOVE LIMITED WARRANTY, WHICH IS THE SOLE AND EXCLUSIVE WARRANTY PROVIDED WITH RESPECT TO THE PRODUCT AND ITS COMPONENTS, THERMA-STOR HEREBY DISCLAIMS ALL EXPRESS AND IMPLIED WARRANTIES, INCLUDING, WITHOUT LIMITATION, THE IMPLIED WARRANTIES OF MERCHANTABILITY AND FITNESS FOR A PARTICULAR PURPOSE.

Warranty Limitations. The foregoing limited warranty extends only to a Customer and shall be null and void upon attempted assignment or transfer. A “defect” under the terms of the limited warranty shall not include problems resulting from Customer’s or Customer’s employees’, agents’, invitees’ or a third party’s misuse, improper installation, improper design of any system in which the Product is included, abuse, lack of normal care, failure to follow written instructions, tampering, improper repair, or freezing, corrosion, acts of nature or other causes not arising out of defects in Therma-Stor’s workmanship or material. If a Product or Component is replaced while under warranty, the applicable limited warranty period shall not be extended beyond the original warranty time period. The limited warranty does not cover any costs related to changes to a Product or Component that may be required by any codes, laws, or regulations that may become effective after initial purchase of the Product by Customer.

Customer Responsibilities. As a further condition to obtaining warranty coverage hereunder, the Customer must send a valid warranty claim to Therma-Stor such that Therma-Stor receives such claim prior to the end of the applicable warranty period. Therma-Stor shall have no obligation hereunder with respect to any claim received by Therma-Stor after the expiration of the applicable warranty period. As a further condition to obtaining warranty coverage hereunder, the Customer must present forms of invoices evidencing proof of purchase of a Product. If such invoices do not clearly indicate the date of initial purchase by a Customer, the applicable Product’s date of manufacture will be used instead of the date of initial purchase for the purpose of calculating the commencement of the applicable warranty period. Warranty service must be performed by Therma-Stor or a servicer authorized by Therma-Stor. In order to obtain warranty service, the Customer should call Therma-Stor at 1-800-533-7533 and ask for the Therma-Stor Products Service Department, which will then arrange for applicable warranty service. Warranty service will be performed during customary, daytime working hours. If the Product must be shipped for service, Customer shall be solely responsible for properly packaging the Product, for all freight charges, and for all risk of loss associated with shipment.

Limitation of Liability. IN NO EVENT SHALL THERMA-STOR, IN CONNECTION WITH THE DESIGN, SALE, INSTALLATION, USE, REPAIR, REPLACEMENT OR PERFORMANCE OF ANY PRODUCT, COMPONENT, PART THEREOF OR WRITTEN MATERIAL PROVIDED THEREWITH, BE LIABLE, TO THE EXTENT ALLOWED UNDER APPLICABLE LAW, UNDER ANY LEGAL THEORY FOR ANY SPECIAL, DIRECT, INDIRECT, COLLATERAL OR CONSEQUENTIAL DAMAGES OF ANY KIND. NOTWITHSTANDING THE ABOVE LIMITATIONS AND WARRANTIES, THE SOLE AND EXCLUSIVE LIABILITY OF THERMA-STOR, REGARDLESS OF THE NATURE OR THEORY OF THE CLAIM, SHALL UNDER NO CIRCUMSTANCES EXCEED THE PURCHASE PRICE OF THE PRODUCT, COMPONENT OR PART UPON WHICH THE CLAIM IS PREMISED.

Applicable Law and Venue. ANY ARBITRATION, ENFORCEMENT OF AN ARBITRATION OR LITIGATION RELATED TO THE PRODUCT WILL BE BROUGHT EXCLUSIVELY IN DANE COUNTY, WISCONSIN, AND CUSTOMER CONSENTS TO THE JURISDICTION OF THE FEDERAL AND STATE COURTS LOCATED THEREIN, SUBMITS TO THE JURISDICTION THEREOF AND WAIVES THE RIGHT TO CHANGE VENUE. CUSTOMER FURTHER CONSENTS TO THE EXERCISE OF PERSONAL JURISDICTION BY ANY SUCH COURT WITH RESPECT TO ANY SUCH PROCEEDING.

Miscellaneous. If any term or condition of this Limited Warranty is found by a court of competent jurisdiction to be invalid, illegal or otherwise unenforceable, the same shall not affect the other terms or conditions hereof or thereof or the whole of this Limited Warranty. Any delay or failure by Therma-Stor to exercise any right or remedy will not constitute a waiver of Therma-Stor to thereafter enforce such rights.



Therma-Stor[®] LLC

PO Box 8680 • Madison, WI 53708

Phone: 608-222-5301 • Fax: 608-222-1447

Web: www.thermastor.com • Email: sales@thermastor.com

Information in this document is subject to change without notice. No part of this document may be reproduced or transmitted in any form or by any means, electronic or mechanical, for any purpose, without the express written permission of Therma-Stor LLC. © 2008 Therma-Stor LLC. All rights reserved.