

# MegaSteam™

86% High Efficiency Oil-fired Steam Boiler



- High Efficiency 86% AFUE
- New, Unique, Burnham Engineered 3-Pass Design
- 4 Sizes Available
  - 288 - 629 sq. ft. of steam
  - 0.75 - 1.65 GPH
- High Corrosion Resistance with Extended Waterside Warranty
- Superior Steam Quality
- Tankless Heater Available
- Best Steam Boiler Warranty in the Industry



 **Burnham**  
Hydronics

## Burnham MegaSteam<sup>™</sup> High Efficiency Oil-fired Steam Boiler

### Unique 3-Pass Cast Iron Design

The MegaSteam boiler has been exclusively designed by Burnham engineers using a 3-pass, cast iron, sectional design that is unequalled in the industry. MegaSteam sections are produced in Burnham's own state-of-the-art foundry, and at 86% AFUE, MegaSteam boilers are ENERGY STAR<sup>®</sup> certified as the most efficient oil-fired steam boilers available.

### Superior Steam Quality

The MegaSteam 3-pass design helps produce high quality 99% dry steam with low moisture content while offering a high degree of corrosion resistance. This outstanding steam quality is incomparable in the industry and allows MegaSteam boilers to outperform competitive products in older steam applications where steam quality is critical.

### Expanded Product Warranty

In addition to Burnham's standard limited 10-year warranty on the cast iron heat exchanger, Burnham warrants each MegaSteam boiler for 5 years against waterside corrosion, a common failure mechanism in steam boilers. The boiler's unique 3-pass design is instrumental in providing this important advantage.

**MegaSteam's expanded corrosion warranty is unmatched in the industry.**

## Benefits of Installing a MegaSteam

### Easy to Install, Maintain, and Service

From installation to servicing, Burnham's MegaSteam boilers have been designed with the contractor in mind. Installation features include a plug-and-play junction box with easy plug-in accessory connections and a reversible swing-away door with an easy connect power cord. For maintenance and servicing, MegaSteam boilers have removeable stainless steel flueway baffles, rear flue cleanout plates and plenty of room in the flueways for easy and efficient cleaning.

### Optional Winter Warmth Assurance Program

The cast iron heat exchangers on MegaSteam boilers are covered by Burnham Hydronics standard limited 10-year manufacturers warranty as well as Burnham's unique 5-year protection against waterside corrosion on every MegaSteam boiler. With the purchase of an optional Burnham Winter Warmth Assurance Plan, a MegaSteam boiler can also include additional coverage on the boiler, boiler components, and labor. This program pays up to 100% for the parts and labor on qualified repairs and covered parts for either 5 or 10 years from the date of installation.

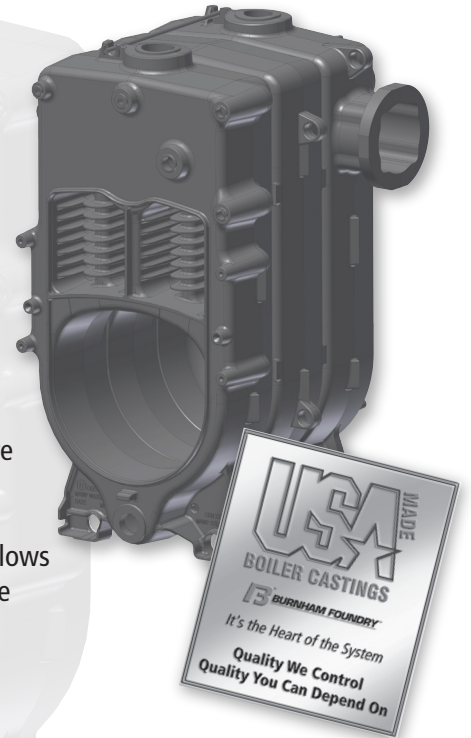

## MegaSteam Boiler Model MST

3-inch jacket insulation  
minimizes heat loss

Readily available controls:

- Honeywell Pressuretrol
- Hydrolevel CG450 LWCO

Reversible, swing-away  
cast iron door

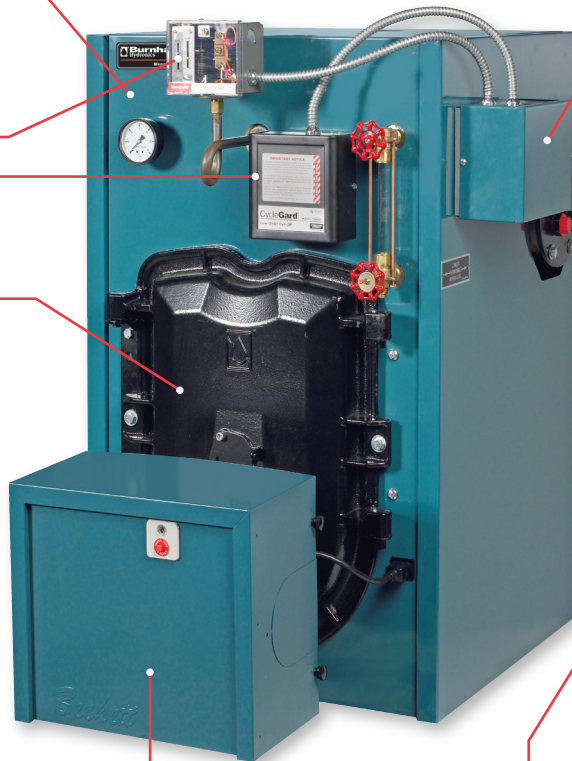

Junction Box with plug-in  
accessory  
connections



### MegaSteam Rear View

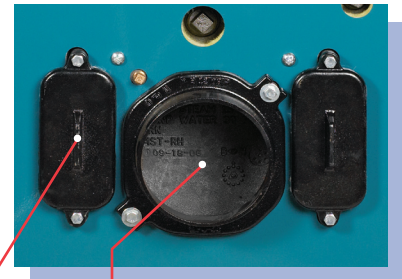

Rear flue outlet provides  
additional space for  
installing steam boiler  
piping

MegaSteam boiler models are  
available with 222A tankless  
heater option, or for even more  
domestic hot water, use a  
Burnham Alliance SL indirect  
fired water heater.

Industry recognized  
Beckett AFG burner  
with cover

Dual, easy access  
cleanout plates for  
cleaning flueways

## Burnham Alliance SL™ Indirect-fired Water Heaters

For an abundant supply of domestic hot water, be sure to use a Burnham Alliance SL indirect-fired water heater with every boiler application.



The Alliance SL water heaters are designed with an effective hydrastone lining that offers superior corrosion resistance and outstanding performance in a wide variety of water conditions.

Water heaters are available in five sizes and come with a unique 10/2/1 warranty – 10 years on the tank and coil, 2 years labor and 1 year on parts.



 **Burnham**  
Hydronics



# Ratings



Boiler Model	Burner Firing Rate		DOE Heating Capacity MBH <sup>2</sup>	I=B=R Net Ratings		Flue Collar Diam. Inches <sup>4</sup>	Minimum Chimney Requirements			ENERGY STAR AFUE %	Water Content (Heater) to NWL Gallons
	GPH	MBH <sup>1</sup>		Steam MBH <sup>3</sup>	Steam Sq. Ft.		Round In. Diam.	Rectangle In. x In.	Height Feet		
MST288	0.75	105	92	69	288	6	6	8 x 8	15	86.0	15.3
MST396	1.05	147	127	96	396	6	6	8 x 8	15	86.0	15.3
MST513	1.35	189	164	123	513	6	6	8 x 8	15	86.0	19.7
MST629	1.65	231	201	151	629	7	7	8 x 8	15	86.0	24.1

Notes: Maximum Working Pressure: 15 PSI Steam

1. The I=B=R Burner Capacity is based on oil having Higher Heating Value of 140,000 BTU/Gal.
2. DOE Heating Capacity and Annual Fuel Utilization Efficiency (AFUE) are based on US Government tests at 13.0% CO<sub>2</sub> with No. 1 maximum smoke and 0.00" draft in the breach on standard equipment package.
3. Net I=B=R Ratings are based upon pick-up allowance of 1.333. Consult manufacturer with unusual piping and pickup requirements before selecting boiler.
4. Used for sizing flue connection materials.

# Optional Tankless Heater Ratings

Boiler Model	*222A Tankless Heater	
	Rating GPM	Pressure Drop PSI
MST288	3.00	22.0
MST396	3.25	24.3
MST513	3.50	26.5
MST629	4.00	31.0

Notes:

1. Tankless Heater Rating, GPM is based on 100 F temperature rise with 40 F inlet water (intermittent draw) with boiler water temperature of 190°F.

# Dimensions

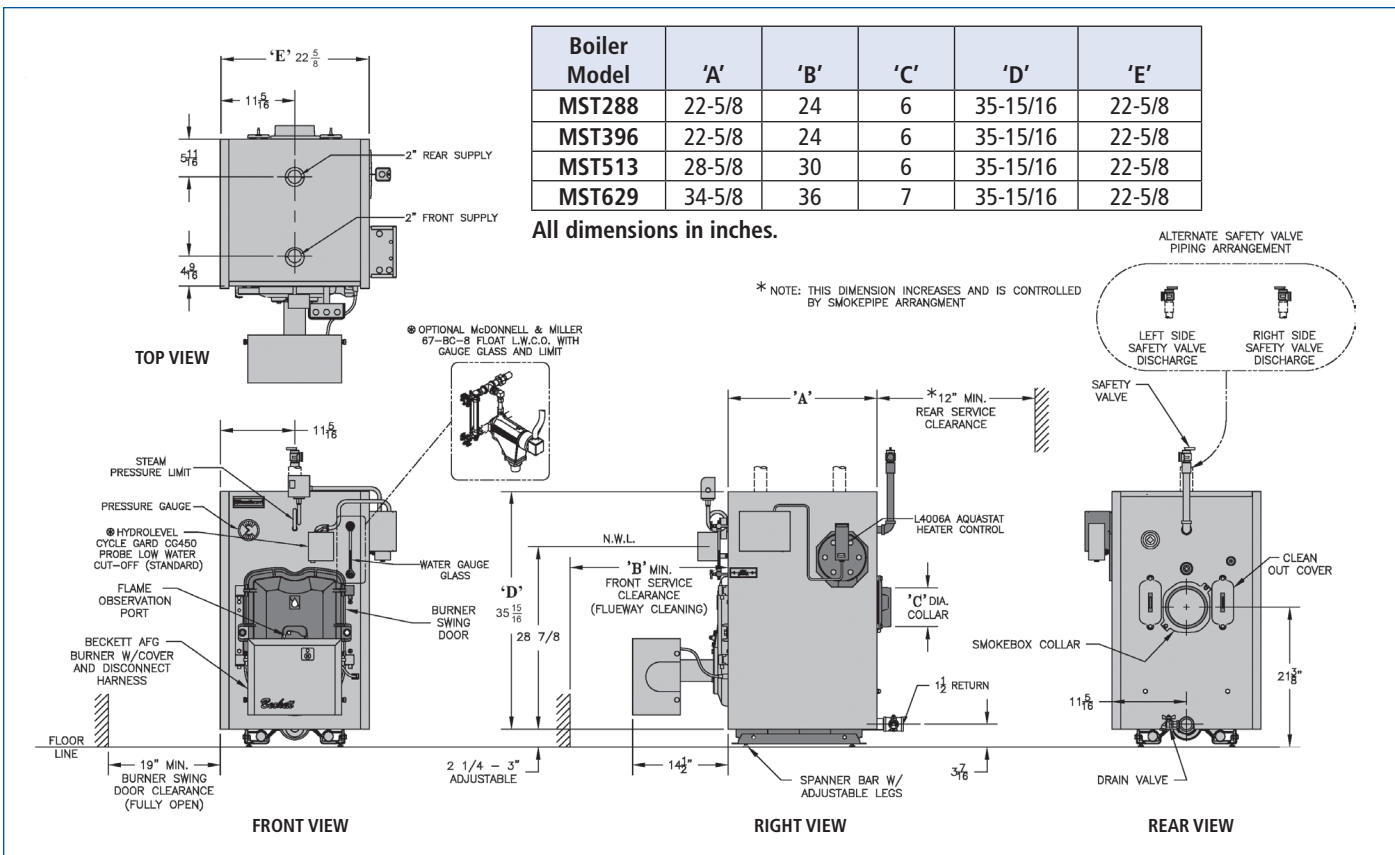

www.burnham.com

© 2007 U.S. Boiler Company, Inc. - Lancaster, PA  
Phone: 1-888-432-8887