

# GWFI

## Gas-Fired Water Boilers

# Boiler Manual



| Contents                         | Page |
|----------------------------------|------|
| 1 Prepare boiler location .....  | 2    |
| 2 Prepare boiler .....           | 6    |
| 3 Vent installation .....        | 7    |
| 4 Install water piping .....     | 13   |
| 5 Install gas piping .....       | 16   |
| 6 Field wiring .....             | 17   |
| 7 Start-up .....                 | 18   |
| 8 Checkout procedure .....       | 20   |
| 9 Sequence of operation .....    | 21   |
| 10 Operating instructions .....  | 23   |
| 11 Service and maintenance ..... | 24   |
| 12 Troubleshooting .....         | 28   |
| 13 Replacement parts .....       | 33   |
| 14 Dimensions .....              | 38   |
| 15 Ratings .....                 | 39   |

### Hazard definitions

**DANGER** Hazards that **will cause severe** personal injury, death or substantial property damage.

**WARNING** Hazards that **can cause severe** personal injury, death or substantial property damage.

**CAUTION** Hazards that **will or can cause minor** personal injury or property damage.

**NOTICE** Special instructions on installation, operation or maintenance that are important but not related to personal injury or property damage.

**WARNING** **INSTALLER** — Read all instructions before installing. **Read page 2 first.** Follow all instructions in proper order to prevent personal injury or death.

- Consider piping and installation when determining boiler location.
- Any claims for damage or shortage in shipment must be filed immediately against the transportation company by the consignee.

**WARNING** **USER** — Please read the following. Failure to comply could result in severe personal injury, death or substantial property damage.

- **This manual is for use only by your qualified heating installer/service technician.**
- Please see the User's Information Manual for your reference.
- Have the boiler serviced by a qualified service technician, at least annually.

**WARNING** This manual must only be used by a **qualified heating installer/service technician.** Failure to comply could result in severe personal injury, death or substantial property damage.

**NOTICE** When calling or writing about the boiler— Please have: • boiler model number from the boiler rating label and • CP number from the boiler jacket. You may list the CP number in the space provided on the "Installation and service certificate" found on page 20.

## Read this first!

**WARNING** Failure to adhere to the guidelines below can result in severe personal injury, death or substantial property damage.

**WARNING** The boiler contains ceramic fiber and fiberglass materials. Use care when handling these materials per instructions on page 40 of this manual. Failure to comply could result in severe personal injury.

### When servicing boiler —

1. To avoid electric shock, disconnect electrical supply before performing maintenance.
2. To avoid severe burns, allow boiler to cool before performing maintenance.

### Boiler operation —

3. Do not block flow of combustion or ventilation air to boiler.
4. Should overheating occur or gas supply fail to shut off, do not turn off or disconnect electrical supply to circulator. Instead, shut off the gas supply at a location external to the appliance.
5. Do not use this boiler if any part has been under water. Immediately call a qualified service technician to inspect the boiler and to replace any part of the control system and any gas control that has been under water.

### Boiler water —

6. DO NOT use petroleum-based cleaning or sealing compounds in boiler system. Water seal deterioration will occur, causing leakage between boiler sections, circulator flanges, diaphragm tanks or other system components. This can result in substantial property damage.
7. DO NOT use "homemade cures" or "boiler patent medicines". Serious damage to boiler, personnel and/or property may result.
8. Continual fresh makeup water will reduce boiler life. Mineral buildup in sections reduces heat transfer, overheats cast iron, and causes section failure. Addition of oxygen and other gases can cause internal corrosion. Leaks in boiler or piping must be repaired at once to prevent makeup water.
9. Do not add cold water to hot boiler. Thermal shock can cause sections to crack.

### Glycol — potential fire hazard —

All glycol is flammable when exposed to high temperatures. If glycol is allowed to accumulate in or around the boiler or any other potential ignition source, a fire can develop. In order to prevent potential severe personal injury, death or substantial property damage from fire and/or structural damage:

- Never store glycol of any kind near the boiler or any potential ignition source.
- Monitor and inspect the system and boiler regularly for leakage. Repair any leaks immediately to prevent possible accumulation of glycol.
- Never use automotive antifreeze or ethylene glycol in the system. Using these glycols can lead to hazardous leakage of glycol in the boiler system.

# 1 Prepare boiler location

## Codes & checklist

### Installations must follow these codes:

- Local, state, provincial, and national codes, laws, regulations and ordinances.
- National Fuel Gas Code, ANSI Z223.1—latest edition.
- Standard for Controls and Safety Devices for Automatically Fired Boilers, ANSI/ASME CSD-1, when required.
- National Electrical Code.
- For Canada only: B149.1 or B149.2 Installation Code, CSA C22.1 Canadian Electrical Code Part 1 and any local codes.

### Certification

**NOTICE** The GWI boiler gas manifold and controls met safe lighting and other performance criteria when boiler underwent tests specified in ANSI Z21.13—latest edition.

### Before locating the boiler:

- Check for nearby connection to:
  - System water piping
  - Venting connections
  - Gas supply piping
  - Electrical power
- Check area around boiler. Remove any combustible materials, gasoline and other flammable liquids.

**WARNING** Failure to keep boiler area clear and free of combustible materials, gasoline and other flammable liquids and vapors can result in severe personal injury, death or substantial property damage.

- Boiler must be installed so that gas control system components are protected from dripping or spraying water or rain during operation or service.
- If new boiler will replace existing boiler, check for and correct system problems, such as:
  1. System leaks causing oxygen corrosion or section cracks from hard water deposits.
  2. Incorrectly-sized expansion tank.
  3. Lack of antifreeze (when required) in boiler water causing system and boiler to freeze and leak.

# 1 Prepare boiler location continued

## Clearances

### Service clearances

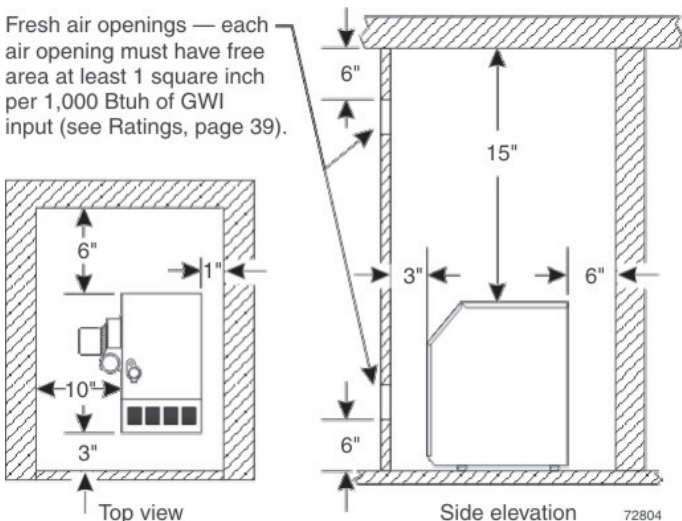
1. Provide minimum clearances for cleaning and servicing the boiler and for access to controls and components as listed in the table below:
2. Provide at least screwdriver clearance to jacket front panel screws for removal of front panel for inspection and minor service. If unable to provide at least screwdriver clearance, install unions and shutoff valves in system so boiler can be moved for servicing.

| Service clearances:                           | Minimum |
|---|---------|
| Top (for cleaning flueways)                   | 35"     |
| Front (for access to controls and components) | 18"     |
| Back  | 7"      |
| Left side (for cleaning and servicing)        | 24"     |
| Right side                                    | 7"      |

### Minimum clearance to combustible materials

1. Hot water pipes must be at least ½" from combustible material.
2. Single-wall vent pipe must be at least 2 inches from combustible material.
3. Type B double-wall metal vent pipe — see vent manufacturer’s recommendation for clearances to combustible material.

**Figure 1** Minimum clearances



### Small space installations

1. When the boiler is located in a closet or small space, provide clearances no less than those shown in Figure 1. The clearances are required to any surface, whether combustible or non-combustible.

## Residential garage installations

Take the following special precautions when installing the boiler in a residential garage, per ANSI Z223.1, paragraph 5.1.9:

- Mount the boiler a minimum of **18 inches above the floor** of the garage to assure the burner and ignition devices will be no less than 18 inches above the floor.
- Locate or **protect the boiler** so it cannot be damaged by a moving vehicle.

## Flooring and foundation

### Flooring

The GWI boiler is approved for installation on combustible flooring, but must never be installed on carpeting.

**WARNING** Do not install boiler on carpeting even if foundation is used. Fire can result, causing severe personal injury, death or substantial property damage.

### Foundation

1. Provide a solid brick or minimum 2-inch thick concrete foundation pad if any of the following is true:
  - floor can become flooded.
  - the boiler mounting area is not level.
2. See Table 1 for minimum foundation dimensions.

**Table 1** Minimum foundation size

| Boiler model   | Minimum foundation length | Minimum foundation width |
|----------------|---------------------------|--------------------------|
| <b>GWI-047</b> | 25"                       | 12"                      |
| <b>GWI-063</b> | 25"                       | 12"                      |
| <b>GWI-095</b> | 25"                       | 15"                      |
| <b>GWI-127</b> | 25"                       | 18"                      |
| <b>GWI-158</b> | 25"                       | 21"                      |
| <b>GWI-190</b> | 25"                       | 24"                      |

# 1 Prepare boiler location continued

## Vent system

**WARNING** Failure to follow all instructions can result in flue gas spillage and carbon monoxide emissions, causing severe personal injury or death.

**DANGER** Inspect existing chimney before installing boiler. Failure to clean or replace perforated pipe or tile lining will cause severe personal injury or death.

**DANGER** Do not alter boiler draft hood or place any obstruction or non-approved vent damper in breeching or vent system. CSA certification will become void. Flue gas spillage and carbon monoxide emissions will occur causing severe personal injury or death.

**NOTICE** GWI boilers can be either chimney draft vented or direct-exhaust vented. See pages 7 to 12 for detailed installation instructions.  
If you are removing an existing boiler from a shared venting system and the new GWI boiler will not share the vent system (allowed only when chimney draft venting), you must test each remaining appliance individually to verify the vent system still operates adequately. Follow guidelines below.

### When removing boiler from existing common vent system:

At the time of removal of an existing boiler, the following steps shall be followed with each appliance remaining connected to the common venting system placed in operation, while the other appliances remaining connected to the common venting system are not in operation.

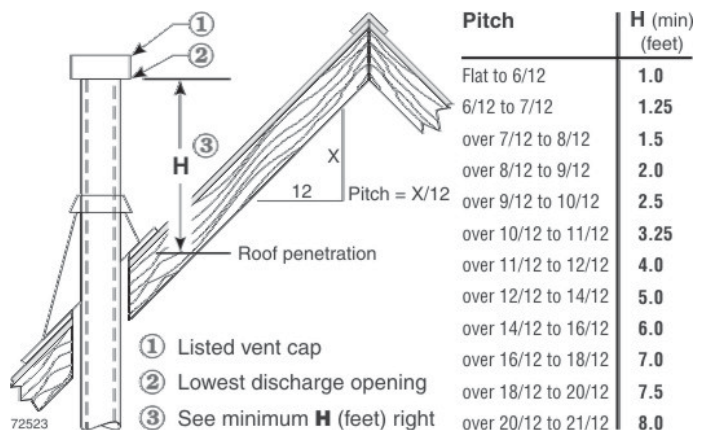
- Seal any unused openings in the common venting system.
- Visually inspect the venting system for proper size and horizontal pitch and determine there is no blockage or restriction, leakage, corrosion or other deficiencies which could cause an unsafe condition.
- Test vent system — Insofar as is practical, close all building doors and windows and all doors between the space in which the appliances remaining connected to the common venting system are located and other spaces of the building. Turn on clothes dryers and any appliance not connected to the common venting system. Turn on any exhaust fans, such as range hoods and bathroom exhausts, so they will operate at maximum speed. Do not operate a summer exhaust fan. Close fireplace dampers.
- Place in operation the appliance being inspected. Follow the lighting/operating instructions. Adjust thermostat so appliance will operate continuously.
- Test for spillage at draft hood relief opening after 5 minutes of main burner operation. Use the flame of a match or candle.
- After it has been determined that each appliance remaining connected to the common venting system properly vents when tested as outlined above, return doors, windows, exhaust fans, fireplace dampers, and any other gas-burning appliance to their previous conditions of use.

Any improper operation of common venting system should be corrected so the installation conforms with the National Fuel Gas Code, ANSI Z223.1 – latest edition. Correct by resizing to approach the minimum size as determined using the appropriate tables in Part 11 of that code. Canadian installations must comply with B149.1 or B149.2 Installation Code.

## Chimney draft vent requirements

- Venting must be installed according to Part 7, Venting of Equipment, of National Fuel Gas Code, ANSI Z223.1-latest edition and applicable building codes. Canadian installations must comply with B149.1 or B149.2 Installation Codes.
- Chimney or vent termination:
  - A chimney, or any vent other than a Type B vent with listed vent cap, must extend at least 3 feet above the highest point where it passes through a roof of a building, and at least 2 feet higher than any portion of a building within a horizontal distance of 10 feet.
  - Type B vents with listed caps may terminate as in Figure 2 if no closer than 8 feet from a vertical wall or similar obstruction.
  - Otherwise, Type B vents must terminate at least 2 feet above the roof penetration and at least 2 feet higher than any portion of a building within 10 feet.
- A lined chimney is preferred and must be used when required by local, state, provincial and national codes, laws, regulations and ordinances. Vitreous tile linings with joints that prevent retention of moisture and linings made of noncorrosive materials are best. Advice for flue connections and chimney linings can be obtained from local gas utility. Type B double-wall metal vent pipe or single-wall vent pipe may be used as a liner.
- Cold masonry chimneys, also known as outside chimneys, typically have one or more walls exposed to outside air. When any atmospheric gas-fired boiler with automatic vent damper is vented through this type of chimney, the potential exists for condensation to occur. Condensation can damage a masonry chimney. Manufacturer recommends the following to prevent possible damage.
  - Line chimney with corrosion-resistant metal liner such as AL29-4C® single-wall stainless steel or B-vent. Size liner per National Fuel Gas Code ANSI Z223.1–latest edition.
  - Provide drain trap to remove any condensate.
- Where two or more gas appliances vent into a common chimney or vent, equivalent area should be at least equal to area of vent outlet on largest appliance plus 50 percent of vent outlet area of additional appliance.

**Figure 2** Terminations with Type B vent fitted with listed cap, provided vent is at least 8 feet from any vertical wall or similar obstruction.



# 1 Prepare boiler location continued

## Air contamination

Please review the following information on potential combustion air contamination problems.

See Table 2 for products and areas which may cause contaminated combustion air.

**WARNING** To prevent potential of severe personal injury or death, check for products or areas listed below before installing boiler. If any of these contaminants are found:

- remove contaminants permanently.
- OR —
- isolate boiler and provide outside combustion air. See national, provincial or local codes for further information.

**Table 2** Corrosive contaminants and likely locations

| <b>Products to avoid</b>   |
|--|
| Spray cans containing chloro/fluorocarbons   |
| Permanent wave solutions   |
| Chlorinated waxes/cleaners   |
| Chlorine-based swimming pool chemicals   |
| Calcium chloride used for thawing  |
| Sodium chloride used for water softening   |
| Refrigerant leaks  |
| Paint or varnish removers  |
| Hydrochloric acid/muriatic acid  |
| Cements and glues  |
| Antistatic fabric softeners used in clothes dryers   |
| Chlorine-type bleaches, detergents, and cleaning solvents found in household laundry rooms |
| Adhesives used to fasten building products and other similar products                      |
| <b>Areas likely to have contaminants</b>   |
| Dry cleaning/laundry areas and establishments  |
| Swimming pools   |
| Metal fabrication plants   |
| Beauty shops   |
| Refrigeration repair shops   |
| Photo processing plants  |
| Auto body shops  |
| Plastic manufacturing plants   |
| Furniture refinishing areas and establishments   |
| New building construction  |
| Remodeling areas   |
| Garages with workshops   |

## Air openings

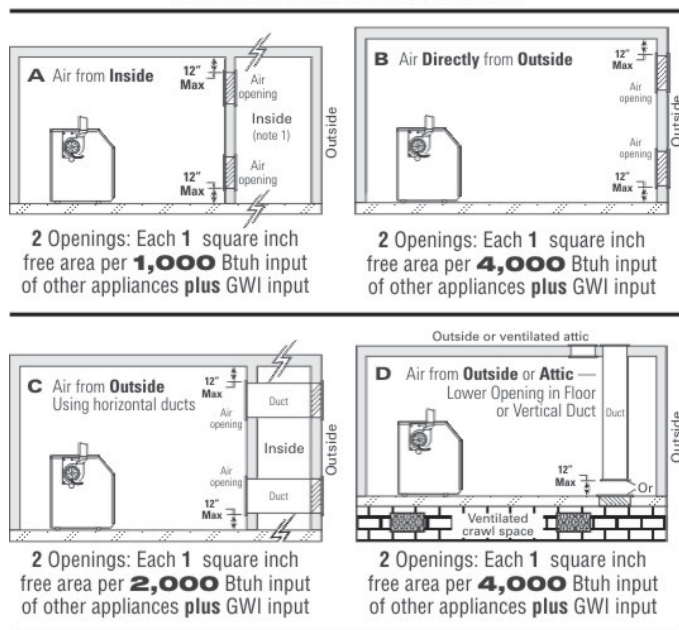
Combustion air and ventilation openings must comply with Section 5.3, “Air for Combustion and Ventilation”, of National Fuel Gas Code ANSI Z223.1—latest edition, or applicable local building codes. Canadian installations must comply with B149.1 or B149.2 Installation Codes.

See table below for minimum combustion/ventilation air opening sizes. Where openings are required, provide two (2) openings — one within 12 inches of the ceiling, the other within 12 inches of the floor, as shown in the table illustrations.

**WARNING** Provide adequate combustion and ventilation air to assure proper combustion and reduce the risk of severe personal injury, death or substantial property damage caused by flue gas spillage and carbon monoxide emissions.

### Minimum air opening sizes (See EXCEPTION below)

Required area of the air openings given in this table are **free area** — after the correction for louver obstruction.



**EXCEPTION: NO** combustion air openings are needed when the boiler (and other appliances) are installed in a space with a volume **NO LESS** than 50 cubic feet per 1,000 Btuh of all installed appliances. Sum the total input of all appliances in MBH (1,000's of Btuh) and multiply this number times 50. **Building must not be of Tight construction** (see definition below).

**Example:** For total input of 100 MBH (100,000 Btuh), minimum volume is 50 x 100 = 5,000 cubic feet. At a ceiling height of 8 feet, space must have at least 5,000 ÷ 8 = 625 square feet (25 feet x 25 feet, for instance).

**Tight construction** means (per ANSI Z223.1): • Walls and ceilings exposed to the outside atmosphere have a continuous water vapor retarder with a rating of 1 perm or less with openings gasketed. **AND** • Weather-stripping has been added on openable windows and doors. **AND** • Caulking or sealants are applied to areas such as joints around windows and door frames, between sole plates and floors, between wall-ceiling joints, between wall panels, at penetrations for plumbing, electrical, and gas lines, and in other openings.

Note 1: If building is of tight construction and air is taken from inside, as in A, provide two openings in building outside wall, one within 12 inches of ceiling, the other within 12 inches of the floor. Each opening must have a minimum free area of 1 square inch per 1,000 Btuh of all appliances in the building.

72840

# 1 Prepare boiler location continued

## Air openings continued

### Exhaust fans and air movers

The appliance space must never be under a negative pressure. Always provide air openings sized not only to the dimensions required for the firing rate of all appliances, but also to handle the air movement rate of the exhaust fans or air movers using air from the building or space.

### Motorized air dampers

If the air openings are fitted with motorized dampers, electrically interlock the damper to:

- Prevent the boiler from firing if the damper is not fully open.
- Shut the boiler down should the damper close during boiler operation.

To accomplish this interlock, wire an *isolated contact* (proving the damper open) in series with the thermostat input to the boiler. The boiler will not start if this contact is open, and will shut down should it open during operation.

# 2 Prepare boiler

## Placement and setup

### Place boiler/crate near position

1. Leave boiler in crate and on pallet until installation site is ready.
2. Move entire crate and pallet next to selected location.
3. Remove crate. Leave boiler on pallet.
4. Remove boiler from pallet as follows:
  - a. Tilt left side of boiler up and place a board under left legs.
  - b. Tilt boiler the other way and place a board under right legs.
  - c. Slide boiler backwards off pallet and into position.
5. Check level.
  - a. Shim legs, if necessary.
  - b. Do not alter legs.

**NOTICE** Do not drop boiler or bump jacket on floor or pallet. Damage to boiler can result.

**WARNING** The boiler contains ceramic fiber and fiberglass materials. Use care when handling these materials per instructions on page 40 of this manual. Failure to comply could result in severe personal injury.

### Inspect orifices and burners

1. Remove front jacket door. Remove base access panel (See Figure 21, item 4, page 34).
2. Check for correctly-sized manifold orifices. See Table 3 for sizing. (The orifice size is stamped on the orifice spud barrel.)

**DANGER** Correctly-sized manifold orifices must be used. Failure to do so will result in severe personal injury, death or substantial property damage.

3. Level and straighten burners.

**DANGER** Burners must be properly seated in slots in burner rest with their openings facing up. Main burner orifices must inject down center of burner. Failure to properly seat burners will result in severe personal injury, death or substantial property damage.

4. Reinstall access panel.

**CAUTION** Do not operate boiler without access panel secured in place. Failure to comply could cause momentary flame rollout on ignition of main flame, resulting in possible fire or personal injury hazard.

**Table 3** Manifold orifice sizing

| Location | Natural gas             |                  | Propane gas             |                  |
|----------|-------------------------|------------------|-------------------------|------------------|
|          | Sea level –<br>2,000 ft | over<br>2,000 ft | Sea level –<br>2,000 ft | over<br>2,000 ft |
| U. S.    | 2.00 mm                 | (Note 1)         | 1.30 mm                 | (Note 1)         |
| Canada   | Sea level –<br>2,000 ft | 2,000 –<br>4,500 | Sea level –<br>2,000 ft | 2,000 –<br>4,500 |
|          | 2.00 mm                 | 1.90 mm          | 1.30 mm                 | 1.20 mm          |

Note 1: For U. S. elevations above 2,000 feet, contact your local supplier for details.

## 2 Prepare boiler continued

### Pressure test

#### Perform hydrostatic pressure test

Pressure test boiler **before** attaching water or gas piping or electrical supply (except as noted below).

#### Prepare boiler for test

1. Remove the shipping nipple (from GWI supply tapping) and remove the boiler relief valve. Temporarily plug the relief valve tapping with a ¾" NPT pipe plug.
2. Remove 1¼" nipple, reducing tee and drain valve from accessory bag. Install in boiler return connection as shown on in Figure 23, item 3, page 36. Install circulator on either the return or supply.
3. Remove 1¼" nipple, 1¼" tee, bushing and pressure/temperature gauge from accessory bag. Pipe to boiler supply connection as shown in Figure 23, item 2, page 36. (Use pipe dope sparingly.)
4. Connect a hose to boiler drain valve, the other end connected to a fresh water supply. Make sure hose can also be used to drain boiler after test.
5. Connect a nipple and shutoff valve to system supply connection on the 1¼" tee. This valve will be used to bleed air during the fill. (Valve and nipple are not included with boiler.)
6. Connect a nipple and shutoff valve to system return connection (at circulator flange if circulator installed on return). This valve will be used to bleed air during the fill. (Valve and nipple are not included with boiler.)

#### Fill and pressure test

1. Open the shutoff valves you installed on supply and return connections.

2. Slowly open boiler drain valve and fresh water supply to fill boiler with water.
3. When water flows from shutoff valves, close boiler drain valve.
4. Close shutoff valves.
5. Slowly reopen boiler drain valve until test pressure of not more than 45 psi is reached on the pressure/temperature gauge.
6. Test at no more than 45 psi for no more than 10 minutes.

**WARNING** Do not leave boiler unattended. A cold water fill could expand and cause excessive pressure, resulting in severe personal injury, death or substantial property damage.

7. Make sure constant gauge pressure has been maintained throughout test. Check for leaks. Repair if found.

**WARNING** Leaks must be repaired at once. Failure to do so can damage boiler, resulting in substantial property damage.

**DANGER** Do not use petroleum-based cleaning or sealing compounds in boiler system. Severe damage to boiler will occur, resulting in substantial property damage.

#### Drain and remove fittings

1. Disconnect fill water hose from water source.
2. Drain boiler at drain valve or out hose, whichever provides best access to drain. Remove hose after draining if used to drain boiler.
3. Remove nipples and valves unless they will remain for use in the system piping.
4. Remove plug from relief valve tapping. See page 13 to replace relief valve.

## 3 Vent installation

### GWV venting options

The GWV boiler can be vented using one of the following methods:

**WARNING** Use only the vent materials and methods outlined in this manual. Use of any other materials or methods could result in vent failure or flue gas leakage, causing severe personal injury, death or substantial property damage.

#### Chimney draft venting

— Uses the natural draft provided by a vertical vent or chimney. When vented using chimney draft venting, GWV boilers are rated as Category I appliances (no pressure in vent and flue gas temperature hot enough to avoid excessive vent condensation). See following section for installation procedures.

Chimney draft installations use:

- a. Vent connector (single or doublewall) sized to eliminate positive pressure in vent system. Diameter increases immediately at boiler. See Figure 3, page 8 for connector sizing.

- b. Double-wall metal vent (B-vent) or chimney with liner approved by the National Fuel Gas Code, ANSI Z223.1—latest edition, or in Canada B149.1 or B149.2 Installation Code.

#### Direct exhaust — vertical or sidewall

— Vent pipe is pressurized and terminated vertically through the roof or through a side wall. When vented as direct exhaust, GWV boilers are rated as Category III appliance (positive pressure in the vent and flue gas temperature hot enough to avoid excessive vent condensation).

You must use only the vent materials listed in this manual. See pages 8 through 12 for installation procedures.

Direct exhaust installations use:

- a. Vent materials specified in this manual.
- b. Vent termination through outside wall, roof or unused chimney. (Tight chimney areas will make vent joint construction very difficult.)

### 3 Vent installation continued

#### Chimney draft venting

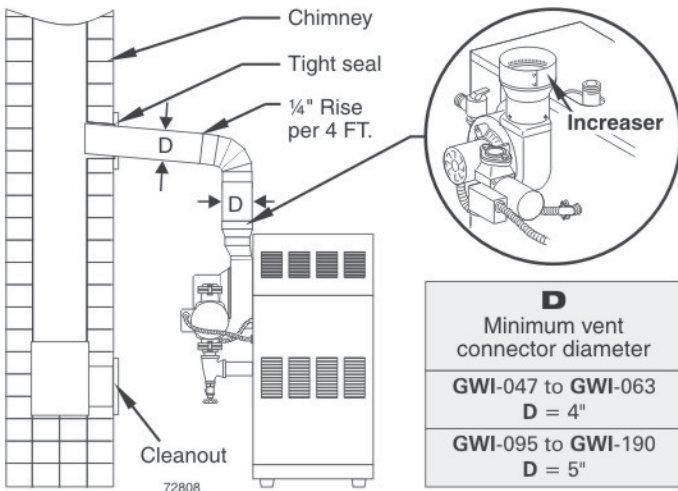
**DANGER** Inspect existing chimney before installing boiler. Failure to clean or replace perforate pipe or lining will cause severe personal injury or death.

**WARNING** Vent sizing given in Figure 3 is only a general guideline. The vent connector and chimney must be designed, sized and constructed in compliance with all applicable codes. Failure to correctly size and install the vent system could result in severe personal injury, death or substantial property damage.

**NOTICE** See page 4 for additional requirements when chimney draft venting.

1. Use doublewall metal vent (B-vent) or chimney with liner as required by the National Fuel Gas Code, ANSI Z223.1–latest edition, or in Canada, B149.1 or B149.2 Installation Code.
2. To prevent downdrafts, chimney should extend at least 3 feet above the highest point where it passes through a roof and at least 2 feet higher than any portion of a building within a horizontal distance of 10 feet.
3. To vent with another appliance, see National Fuel Gas Code, ANSI Z223.1–latest edition or in Canada B149.2 or B149.2 Installation Code
4. Do not connect breeching to any portion of a mechanical draft system that can operate under positive pressure.
5. Maintain minimum 2" clearance from combustible materials to vent pipe.
6. Do not use chimney with an open fireplace.
7. Make horizontal runs as short as possible. Long runs can cause condensation.
8. When longer runs are used, support pipe with appropriate hangers.
9. To prevent blockage, do not vent into bottom of chimney.
10. Vent pipe must not go beyond inside wall of chimney.
11. Vent passing through floors or ceilings must be firestopped.
12. See Figure 3 to connect boiler to venting system.

**Figure 3** Chimney draft venting installation





### 3 Vent installation continued

#### Direct exhaust venting

1. Select a vent pipe manufacturer from separate **GW**I and **GWS Vent Component Supplement** and obtain all vent components needed, based on boiler location and venting method.
2. You must use the vent starter (see below) made by the vent pipe manufacturer. See **GW**I and **GWS Vent Component Supplement** for part number of each component, listed by vent manufacturer.

**WARNING** Use only the vent starter of the same manufacturer as the vent components. Do not mix components from different systems. The vent system could fail, causing flue gas spillage, resulting in severe personal injury or death.

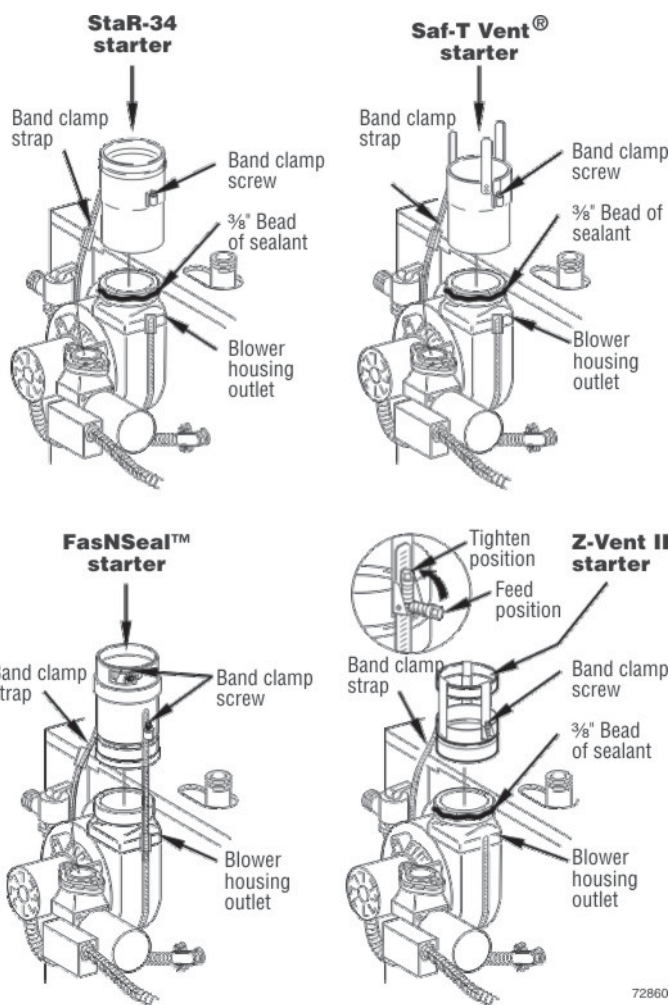
3. Follow all applicable national, state, local or provincial codes when venting the **GW**I boiler.
4. Connect vent starter to blower housing outlet as shown below.
  - a. Do not mix components from different vent manufacturers.
  - b. Maintain minimum 2" clearance from combustible materials to vent pipe.
  - c. Seal with sealant specified by vent pipe manufacturer, using  $\frac{3}{8}$ " bead (not required for FasNSeal™).
  - d. Tighten strap at band clamp screw until strap is snug around blower housing.

#### Obtain vent system components

1. The following special gas vent systems comply with UL-1738 and ULC-S636 standards and are certified by CSA as the only systems suitable for use with **GW**I boilers (all 3" diameter):
  - Heat-Fab, Inc. Saf-T Vent®
  - Flex-L International, Inc. StaR-34
  - Z-Flex®, Inc. Z-Vent II
  - ProTech Systems FasNSeal™

**WARNING** Use only the vent starter of the same manufacturer as the vent components. Do not mix components from different systems. The vent system could fail, causing flue gas spillage, resulting in severe personal injury or death.

2. Select vertical or sidewall venting depending on job requirements.
3. Refer to Table 4 for maximum vent run lengths and number of elbows. Do not exceed data in Table 4.
4. Select vent components from separate **GW**I and **GWS Vent Component Supplement**. All components, including the vent starter, must be of the same vent manufacturer. Do not mix components.



**Table 4** Maximum vent length

| Max.vent length<br>(feet)          | Total number of 90° elbows<br>(Notes 1 & 2) |    |    |    |    |    |
|------------------------------------|---|----|----|----|----|----|
|                                    | 1   | 2  | 3  | 4  | 5  | 6  |
| <b>GW</b> I-047 to <b>GW</b> I-158 | 55  | 48 | 41 | 34 | 27 | 20 |
| <b>GW</b> I-190                    | 35  | 28 | 21 | 14 | 7  | -- |

Notes:  
 1. Do not include termination fitting when counting total number of elbows.  
 2. One (1) 90° elbow is equivalent to two (2) 45° elbows.

### 3 Vent installation continued

#### Direct exhaust venting continued

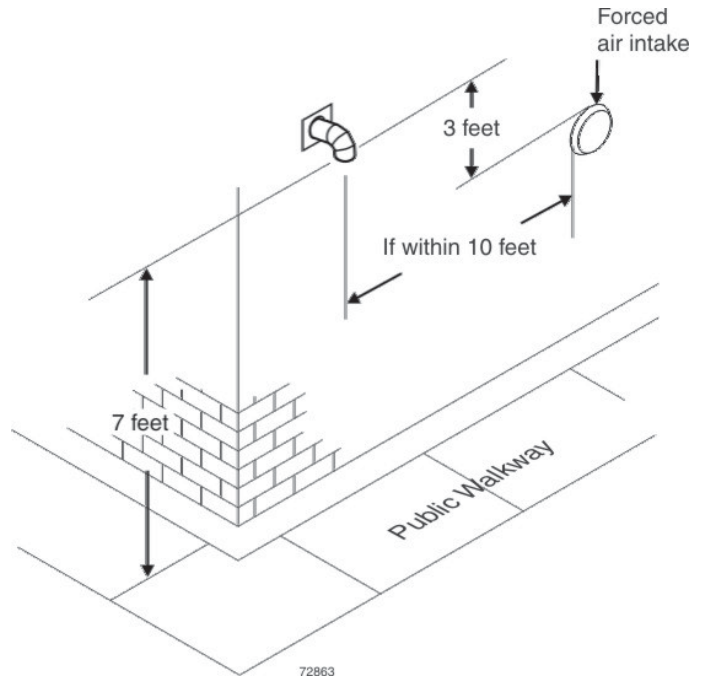
##### Vent termination location

**WARNING** Follow instructions on this page when determining vent location to avoid possibility of severe personal injury, death or substantial property damage.

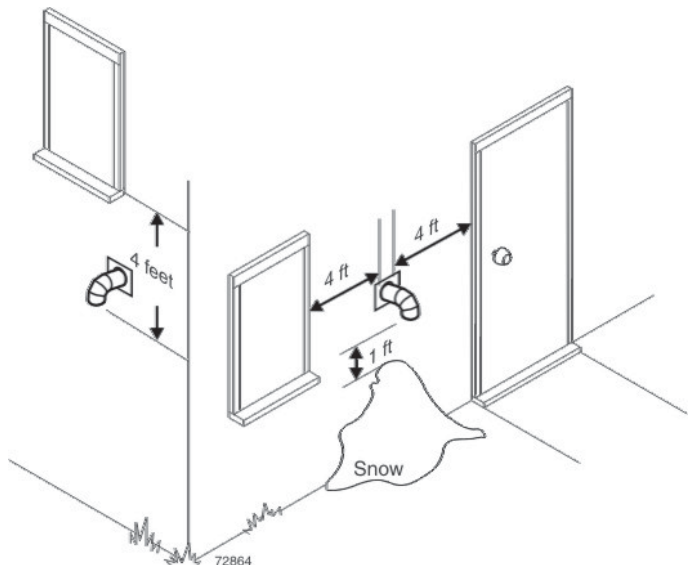
1. Locate the boiler and vent penetration through the wall so all requirements on this page and in Figures 4 and 5 will be met. Also follow vent manufacturer's instructions.
2. Gases will form white plume in winter. Plume could obstruct window view.
3. Prevailing winds could cause freezing of condensate and water/ice buildup on vent termination, building, plants or roof. Ice buildup on vent termination can cause boiler shutdown and building freezeup.
4. Winds over 31 mph can cause nuisance boiler shutdown if boiler is sidewall vented. This could result in loss of heat to building, causing freezeup.
5. Locate or guard vent termination to prevent condensate from damaging exterior surfaces.
6. Locate the vent termination well away from trees, shrubs, and decorative items.
7. Locate or guard vent to prevent accidental contact by people or pets.
8. Do not terminate vent in window well, stairwell, alcove, courtyard, or other recessed areas.
9. Do not wrap or insulate vent pipe or fittings.
10. Do not terminate vent above any door or window. Condensate can freeze, causing ice formations.
11. Do not connect:
  - Any other appliance to vent pipe.
  - Multiple boilers to a common vent pipe.
12. Canadian installations — See B149.1 or B149.2 Installation Code. Terminate vent no less than 6 feet from another combustion air inlet, 3 feet from any other building opening, and 3 feet from any gas service regulator.
13. See Figures 4 and 5, showing that the vent must terminate:
  - at least 7 feet above public walkway.
  - 3 feet above any forced air intake within 10 feet.
  - more than 4 feet below or to side of all doors or windows.
  - more than 1 foot above grade or anticipated snow line.
14. Vent must also terminate:
  - at least 6 feet away from adjacent walls.
  - no closer than 5 feet below roof overhang.
  - at least 4 feet horizontally (and in no case above or below unless a 4 foot horizontal distance is maintained) from electric meters, gas meters, regulators, relief valves, and other equipment.
15. Site conditions may dictate greater clearances.
16. Do not extend exposed vent pipe outside of building. Condensate could freeze and block vent pipe.

**WARNING** A gas vent extending through an exterior wall shall not terminate adjacent to the wall or below building extensions such as eaves, overhangs, balconies or decks. Failure to comply could result in severe personal injury, death or substantial property damage.

**Figure 4** Maintain minimum clearances from public walkways and building air openings



**Figure 5** Maintain minimum clearances from doors, windows and snow line



## 3 Vent installation continued

### Direct exhaust venting continued

#### Installing direct exhaust vent and termination

1. Do not mix types or manufacturers of vent materials.

**WARNING** Use only the vent starter of the same manufacturer as the vent components. Do not mix components from different systems. The vent system could fail, causing flue gas spillage, resulting in severe personal injury or death.

2. Clean all joints before sealing. See vent manufacturer's instructions for cleaning and sealing joints. Use their specified sealant. Do not use screws.
3. Install vent pipe with seams on top of vent horizontal runs. Follow requirements on page 10 for vent termination location.
4. Maintain minimum 2" clearance from combustible materials to vent pipe.
5. Vertical venting — See Figure 6. Follow vent manufacturer's instructions for venting through roof.
  - Vent pipe must extend through roof flashing, jacket or thimble.
  - Vent may pass through floor, inside wall or concealed space when installed according to vent manufacturer's instructions.

Sidewall venting — See Figures 7 and 8. Vent must terminate at least one foot above anticipated snowline. Vent must be terminated only with:

- Elbow with integral screen.

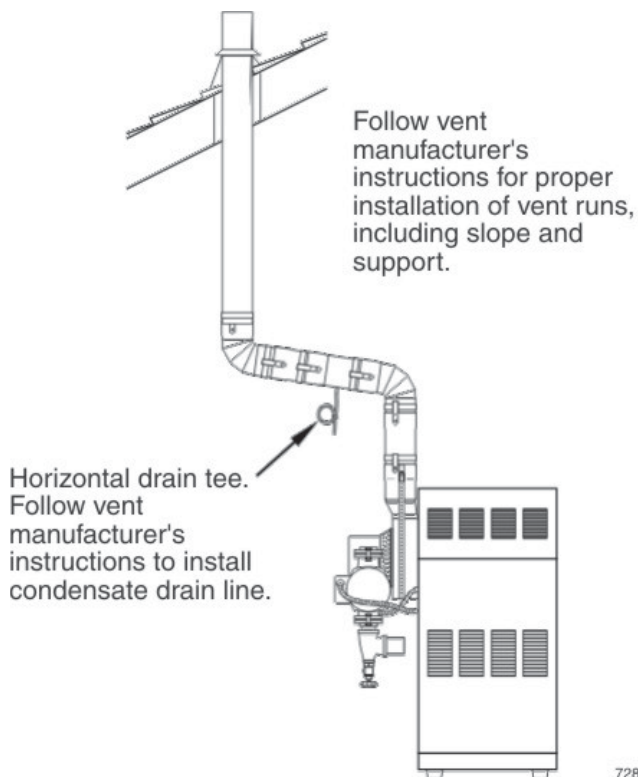
- Elbow and termination coupling with screen (not available for StaR-34).
6. Do not seal vent pipe (slip connector for Saf-T Vent) to inside or outside plate.
  7. If passing through noncombustible wall, provide hole diameter large enough to insert the vent pipe (slip connector for Saf-T Vent).
  8. Install horizontal drain tee as close as possible to boiler, in first horizontal run. See Figure 7.
  9. Do not exceed the maximum vent system length given in Table 4, page 9.

**WARNING** Condensate drain line — use only silicone tubing rated for at least 400 °F for the first 18" of condensate drain line, then other non-metallic tubing may be used. Using any other material could cause flue gas leakage, potentially resulting in severe personal injury, death or substantial property damage.

- CAUTION** On some installations, the condensate drain fitting may be omitted, provided:
- Vent manufacturer shows this option in their instructions.
  - Vent is sloped toward termination as shown in dotted lines in Figure 7.
  - The vent is installed per boiler manufacturer's and vent manufacturer's instructions.

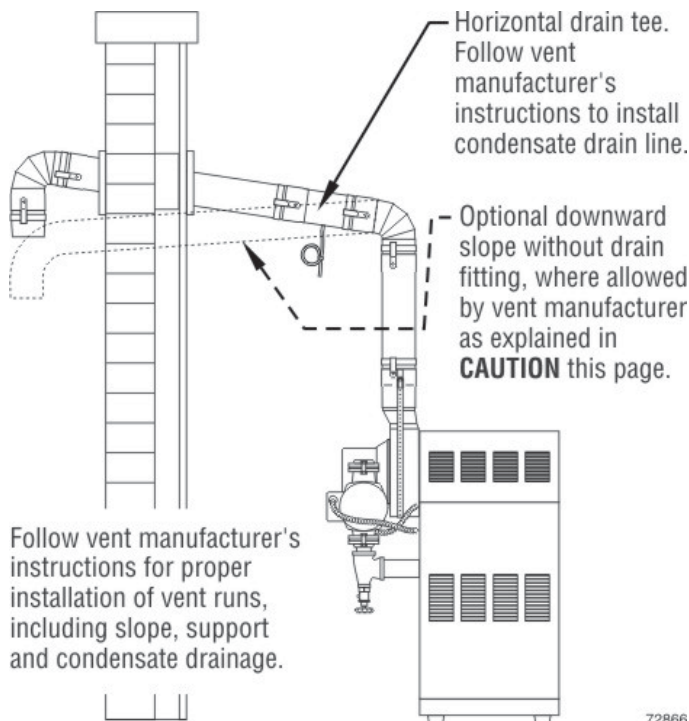
Condensate drippage from such vents may accumulate on the ground below. Consider traffic in the area to avoid hazard due to ice accumulation.

**Figure 6** Vertical direct exhaust installation



72865

**Figure 7** Direct exhaust through side wall



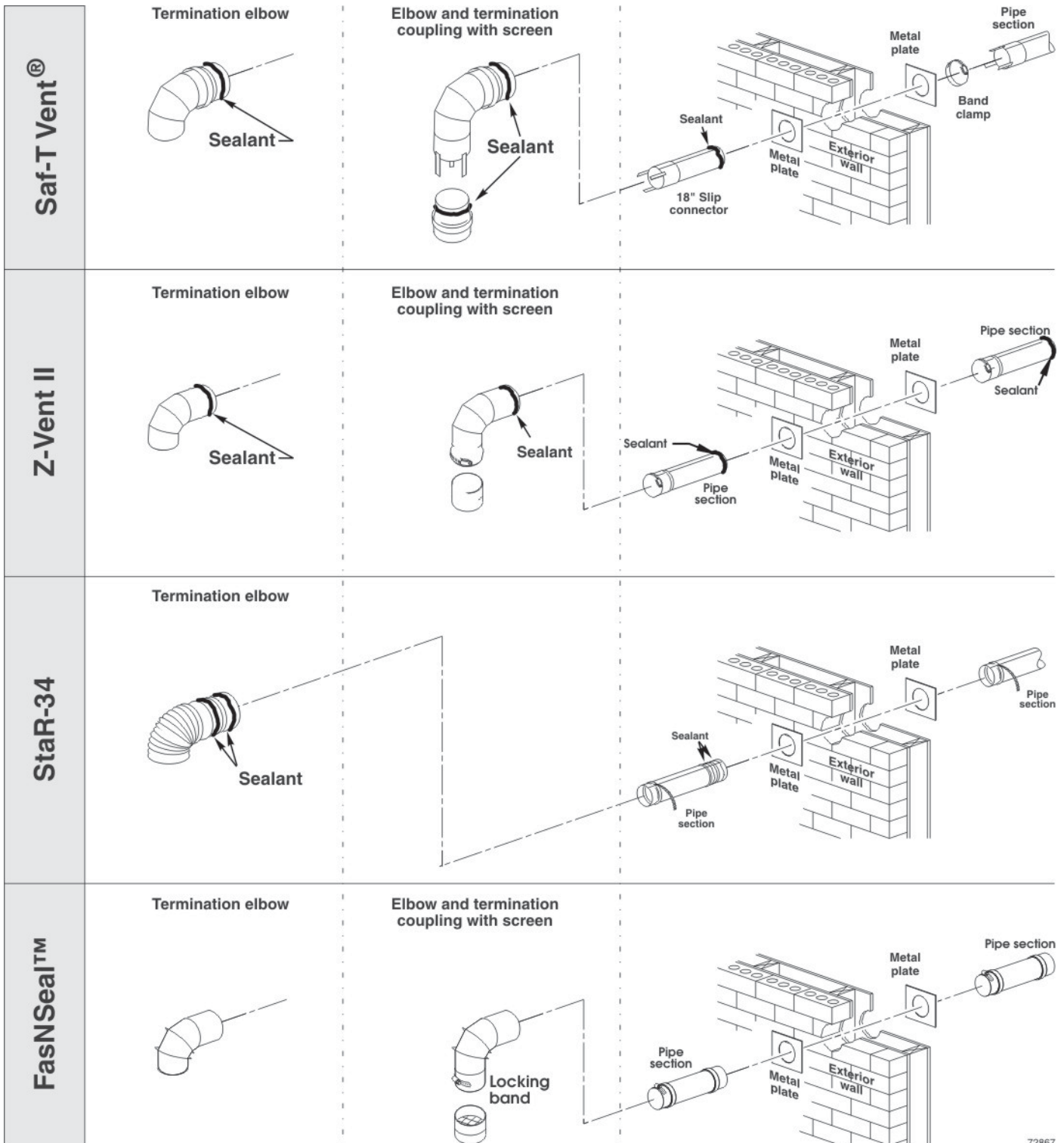
72866

### 3 Vent installation continued

#### Direct exhaust venting continued

Figure 8 Sidewall vent termination options and installation requirements

**WARNING** Using any termination other than one of those shown could cause nuisance outages and loss of heat, resulting in substantial property damage.



72867

## 4 Install water piping

### General

If installation is to comply with ASME or Canadian requirements, an additional high temperature limit is needed. Install control in supply piping between boiler and isolation valve. Set second control to minimum 20 °F above setpoint of first control. Maximum allowable setpoint is 240 °F. See page 22 for wiring.

A low water cutoff device is required when boiler is installed above radiation level or by certain state or local codes or insurance companies. Use low water cutoff designed for water installations. Electrode probe-type is recommended. Purchase and install in tee in supply piping above boiler.

Use backflow check valve in cold water supply if required by local codes.

### Near-boiler piping

See Figure 9 (diaphragm-type or bladder-type expansion tank) or Figure 10 (closed-type expansion tank) on page 14, and Table 6, for near-boiler and single-zone systems designed for return water at least 130 °F.

See page 13 for multiple-zone piping.

See page 14 for boilers used with refrigeration systems.

### Relief valve

Install relief valve vertically in ¾" tapping on side of boiler. See the tag attached to the relief valve for manufacturer's instructions.

**WARNING** To avoid water damage or scalding due to valve operation, discharge line must be connected to relief valve outlet and run to a safe place of disposal. Terminate the discharge line to eliminate possibility of severe burns should the valve discharge.

- Discharge line must be as short as possible and be the same size as the valve discharge connection throughout its entire length.
- Discharge line must pitch downward from the valve and terminate at least 6" above the floor drain where any discharge will be clearly visible.
- The discharge line shall terminate plain, not threaded, with a material serviceable for temperatures of 375 °F or greater.
- Do not pipe the discharge to any place where freezing could occur.
- No shutoff valve shall be installed between the relief valve and boiler, or in the discharge line. Do not plug or place any obstruction in the discharge line.
- Failure to comply with the above guidelines could result in failure of the relief valve to operate, resulting in possibility of severe personal injury, death or substantial property damage.
- Test the operation of the valve after filling and pressurizing system by lifting the lever. Make sure the valve discharges freely. If the valve fails to operate correctly, replace it with a new relief valve.

### Near-boiler piping continued

**Table 6** Water pipe size (based on 20 °F rise)

| Boiler model number | To system | From system |
|---------------------|-----------|-------------|
| GWI-047             | ¾"        | ¾"          |
| GWI-063             | 1"        | 1"          |
| GWI-095             | 1"        | 1"          |
| GWI-127             | 1"        | 1"          |
| GWI-158             | 1 ¼"      | 1 ¼"        |
| GWI-190             | 1 ¼"      | 1 ¼"        |

### Circulator

The circulator is shipped loose (wiring pre-attached to boiler) to allow you to locate it either in the return or supply piping, as desired. See page 14 for a typical installation. Pipe the expansion tank to the suction side of the circulator whenever possible. Install an air separator in the supply piping. Connect the expansion tank to the air separator only if the separator is on the suction side of the circulator. Always install the system fill connection at the same point as the expansion tank connection to the system. Figures 4 and 5 show typical near-boiler piping connections.

### Expansion tank

#### Diaphragm- or bladder-type expansion tank — Figure 9, page 14

1. Ensure expansion tank size will handle boiler and system water volume and temperature. Tank must be located in boiler return piping as close to boiler as possible, before inlet side of circulator. See tank manufacturer's instructions for details.
2. Install an automatic air vent as shown.

#### Closed-type expansion tank — Figure 10, page 14

1. Ensure expansion tank size will handle boiler and system water volume and temperature. See tank manufacturer's instructions for details.
2. Connect tank to ½" NPT tapping located behind supply outlet, using ½" NPT piping. Pitch any horizontal piping up towards tank 1 inch per 5 feet of piping.

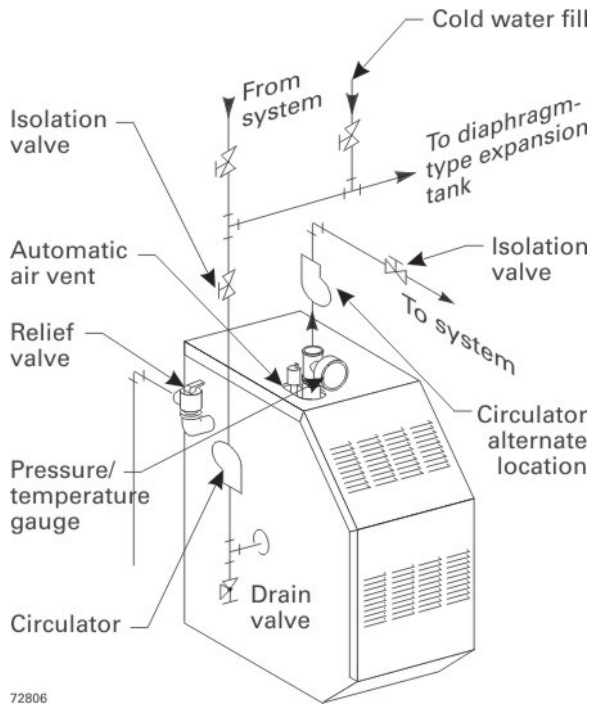
**CAUTION** Undersized expansion tanks cause system water to be lost from relief valve and makeup water to be added through fill valve. Eventual section failure can result.

### Water piping — multiple zone systems

Install system piping using either circulator zoning or zone valve zoning. Install expansion tank on suction side of system pump. Always connect fill line only at the expansion tank — never at another point in the system.

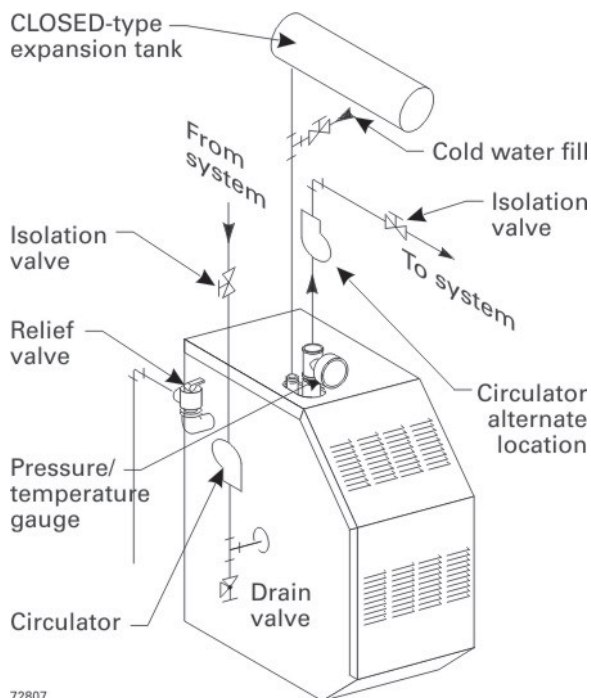
## 4 Install water piping continued

**Figure 9** Diaphragm- or bladder-type expansion tank: Piping to single-zone system using diaphragm-type or bladder-type expansion tank. See Table 6, page 13, for piping sizes.



72806

**Figure 10** Closed-type expansion tank: Piping to single-zone system using closed-type expansion tank. See Table 6, page 13, for piping sizes.



72807

**WARNING** Use Figure 9 or Figure 10 only for systems designed for return water at least 130 °F. For systems with low return water temperature, such as converted gravity systems and radiant heating systems, install bypass piping (see page 15) to protect boiler against condensation. Failure to prevent low return water temperature to the boiler could cause corrosion of the boiler sections or burners, resulting in severe personal injury, death or substantial property damage.

**WARNING** If system includes radiant heating circuits, provide piping and controls to regulate the temperature supplying the radiant circuits. Failure to comply could result in substantial property damage.

**WARNING** Install boiler so that chilled medium is piped in parallel with heating boiler. Use appropriate valves to prevent chilled medium from entering boiler. Consult I=B=R Installation and Piping Guides.

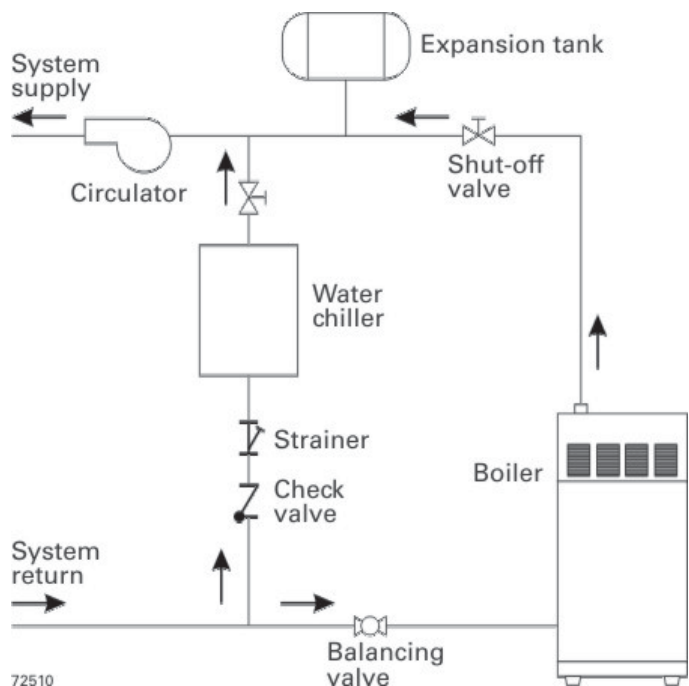
If boiler is connected to heating coils located in air handling units where they can be exposed to refrigerated air, use flow control valves or other automatic means to prevent gravity circulation during cooling cycle. Circulation of cold water through the boiler could result in damage to the heat exchanger, causing possible severe personal injury, death or substantial property damage.

### Water piping — refrigeration systems

#### Prevent chilled water from entering boiler

Install boiler so that chilled medium is piped in parallel with the heating boiler. Use appropriate valves to prevent chilled medium from entering boiler. See Figure 11 for typical installation of balancing valve and check valve.

**Figure 11** Piping refrigeration systems

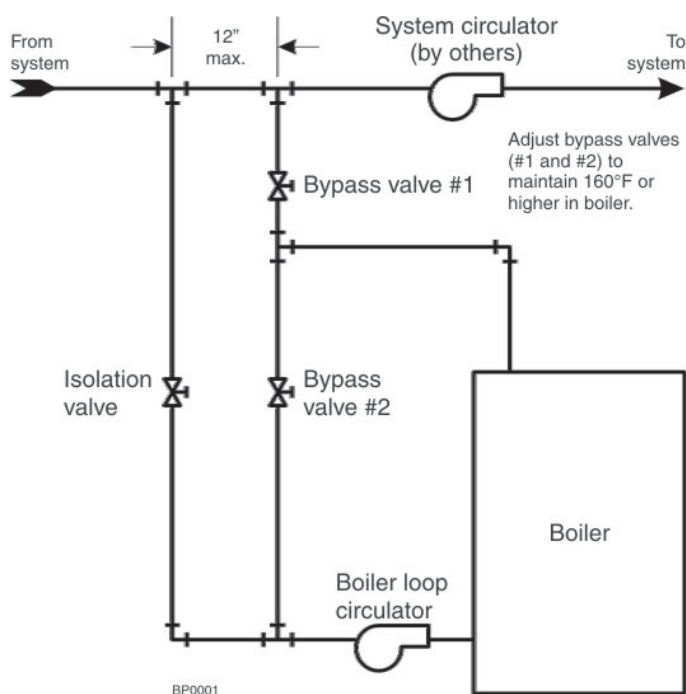


72510

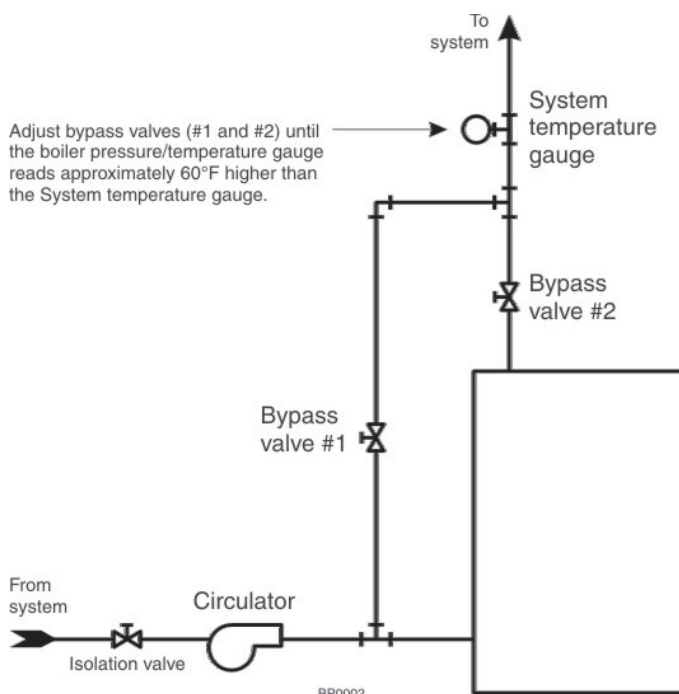
## 4 Install water piping continued

### Near-boiler piping continued

**Figure 12** System bypass piping in boiler loop with separate system circulator, using primary/secondary piping



**Figure 13** Boiler bypass piping — use only for high water content systems — DO NOT use for radiant panel systems



#### System bypass method

1. Apply bypass piping of Figure 12 to high water content systems, radiant panel systems or any system that is likely to operate with low return water temperature for extended periods.
2. The bypass arrangement shown protects the boiler from damage caused by condensate corrosion due to low return water temperature and protects low temperature systems from too high a supply temperature.
3. Adjust the bypass valves as indicated below.

#### Adjust Bypass valves 1 and 2 as follows:

1. Start with valve 2 fully closed, valve 1 fully open.
2. Slowly open valve 2 while closing valve 1. Adjust the valves until the boiler pressure/temperature gauge reads 160 °F or higher. As you open the valves, pause long enough to allow temperatures to level off. It takes a while for the boiler water temperature to rise as the flow changes.
3. Bypass valve 2 allows hot boiler outlet water to blend with colder return water, raising the supply temperature to the boiler. Bypass valve 1 balances the pressure drop through valve 2.
4. The purpose of this piping is to raise the return water temperature to the boiler enough to prevent condensation of flue gases.

#### Boiler bypass method

1. Apply bypass piping of Figure 13 to high water content systems, such as converted gravity systems.
2. The bypass arrangement shown protects the boiler from damage caused by condensate corrosion due to low return water temperature. This method does not provide protection from high temperature water being supplied to the system.
3. DO NOT apply this piping to radiant panel systems.
4. Adjust the bypass valves as indicated below.

#### Adjust Bypass valves 1 and 2 as follows:

1. Start with valve 1 fully closed, valve 2 fully open.
2. Slowly open valve 1 while closing valve 2. Adjust the valves until the boiler pressure/temperature gauge reads approximately 60 °F higher than the system temperature gauge. As you open the valves, pause long enough to allow temperatures to level off. It takes a while for the boiler water temperature to rise as the flow changes.
3. Bypass valve 1 controls system flow rate. Bypass valve 2 controls flow through the boiler.
4. The purpose of this piping is to cause a high enough temperature rise in the boiler that the average temperature will be warm enough to prevent condensation of flue gases.

**WARNING** Install all components specified above and adjust valves as described to prevent low temperature in the boiler. Failure to prevent low water temperature in the boiler could cause corrosion of the boiler sections or burners, resulting in severe personal injury, death or substantial property damage.

## 5 Install gas piping

### Connecting gas supply piping to boiler

1. Remove jacket front panel and see Figure 14 to pipe gas to boiler.
  - a. Install drip leg at inlet of gas connection to boiler. Where local utility requires drip leg to be extended to the floor, use appropriate length of nipple between cap and tee.
  - b. Install ground joint union for servicing, when required.
  - c. Install manual shutoff valve in gas supply piping outside boiler jacket when required by local codes or utility requirements.
  - d. In Canada — When using manual main shutoff valve, it must be identified by the installer.
2. Support piping with hangers, not by boiler or its accessories.
3. Purge all air from gas supply piping.
4. Before placing boiler in operation, check boiler and its gas connection for leaks.
  - a. Close manual main shutoff valve during any pressure testing at less than 13" w.c.
  - b. Disconnect boiler and gas valve from gas supply piping during any pressure testing greater than 13" w.c.

**WARNING** Do not check for gas leaks with an open flame — Use bubble test. Failure to use bubble test or check for gas leaks can cause severe personal injury, death or substantial property damage.

5. Use pipe dope compatible with propane gases. Apply sparingly only to male threads of pipe joints so that pipe dope does not block gas flow.

**WARNING** Failure to apply pipe dope as described in this manual can result in severe personal injury, death or substantial property damage.

#### Natural Gas:

1. See Table 7 for pipe length and diameter. Base on rated boiler input (divide by 1,000 to obtain cubic feet per hour). Table 7 is only for gas with specific gravity 0.60, with a pressure drop through the gas piping of 0.30" w.c. For additional gas pipe sizing information, see ANSI Z223.1 (B149.1 or B149.2 for Canadian installations).
2. Inlet pressure required at gas valve inlet:
  - Maximum: 13" w.c.
  - Minimum: 5" w.c.
  - Manifold gas pressure: 3.5" w.c.
3. Install 100% lockup gas pressure regulator in supply line if inlet pressure exceeds 13" w.c. Adjust for 13" w.c. maximum.

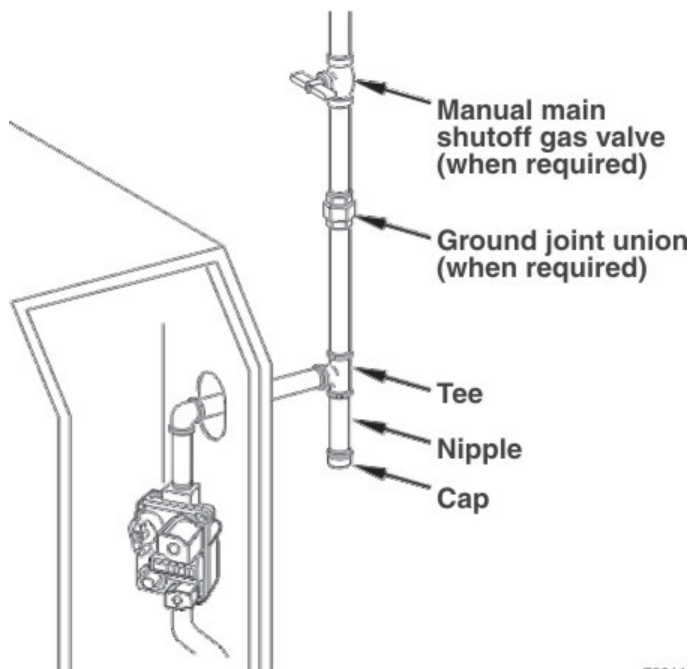
#### Propane Gas:

1. Contact gas supplier to size pipes, tanks and 100% lockup gas pressure regulator.
2. Adjust propane supply regulator provided by gas supplier for 13" w.c. maximum pressure.
3. Inlet pressure required at gas valve inlet:
  - Maximum: 13" w.c.
  - Minimum: 11" w.c.
  - Manifold gas pressure: 10" w.c.

**Table 7** Pipe capacity for 0.60 specific gravity natural gas

| Gas pipe length (feet) | Capacity of pipe for pipe size of:<br>(Capacity in cubic feet gas per hour) |      |     |        |        |
|------------------------|---|------|-----|--------|--------|
|                        | 1/2"  | 3/4" | 1"  | 1 1/4" | 1 1/2" |
| 10                     | 132   | 278  | 520 | 1050   | 1600   |
| 20                     | 92  | 190  | 350 | 730    | 1100   |
| 30                     | 73  | 152  | 285 | 590    | 860    |
| 40                     | 63  | 130  | 245 | 500    | 760    |
| 50                     | 56  | 115  | 215 | 440    | 670    |
| 75                     | 45  | 93   | 175 | 360    | 545    |
| 100                    | 38  | 79   | 150 | 305    | 460    |
| 150                    | 31  | 64   | 120 | 250    | 380    |

**Figure 14** Gas supply piping



72811



## 6 Field wiring

**WARNING** For your safety, turn off electrical power supply at service entrance panel before making any electrical connections to avoid possible electric shock hazard. Failure to do so can cause severe personal injury or death.

**NOTICE** Wiring must be N.E.C. Class 1.  
If rollout thermal fuse element wire as supplied with boiler must be replaced, type 200 °C wire or equivalent must be used. If other original wiring as supplied with boiler must be replaced, use only type 105 °C wire or equivalent.  
Boiler must be electrically grounded as required by National Electrical Code ANSI/NFPA 70-latest edition.

### Electrical installation must comply with:

1. National Electrical Code and any other national, state, provincial or local codes or regulations.
2. In Canada, CSA C22.1 Canadian Electrical Code Part 1, and any local codes.

### Wiring connections

Boiler is shipped with controls completely wired. See wiring diagram on page 22 for details. Circulator is shipped loose, but wiring harness is pre-attached to the boiler. Connect wires in circulator junction box.

### Thermostat

1. Connect thermostat as shown on wiring diagram on boiler.
2. Install on inside wall away from influences of drafts, hot or cold water pipes, lighting fixtures, television, sunrays or fireplaces.
3. If thermostat has a heat anticipator, set heat anticipator in thermostat to match power requirements of equipment connected to it. If connected directly to boiler, see Wiring diagram, page 22, for anticipator setting. For other devices, see manufacturer's specifications. Wiring diagram on boiler gives setting for control module and gas valve. Also see instructions with thermostat.

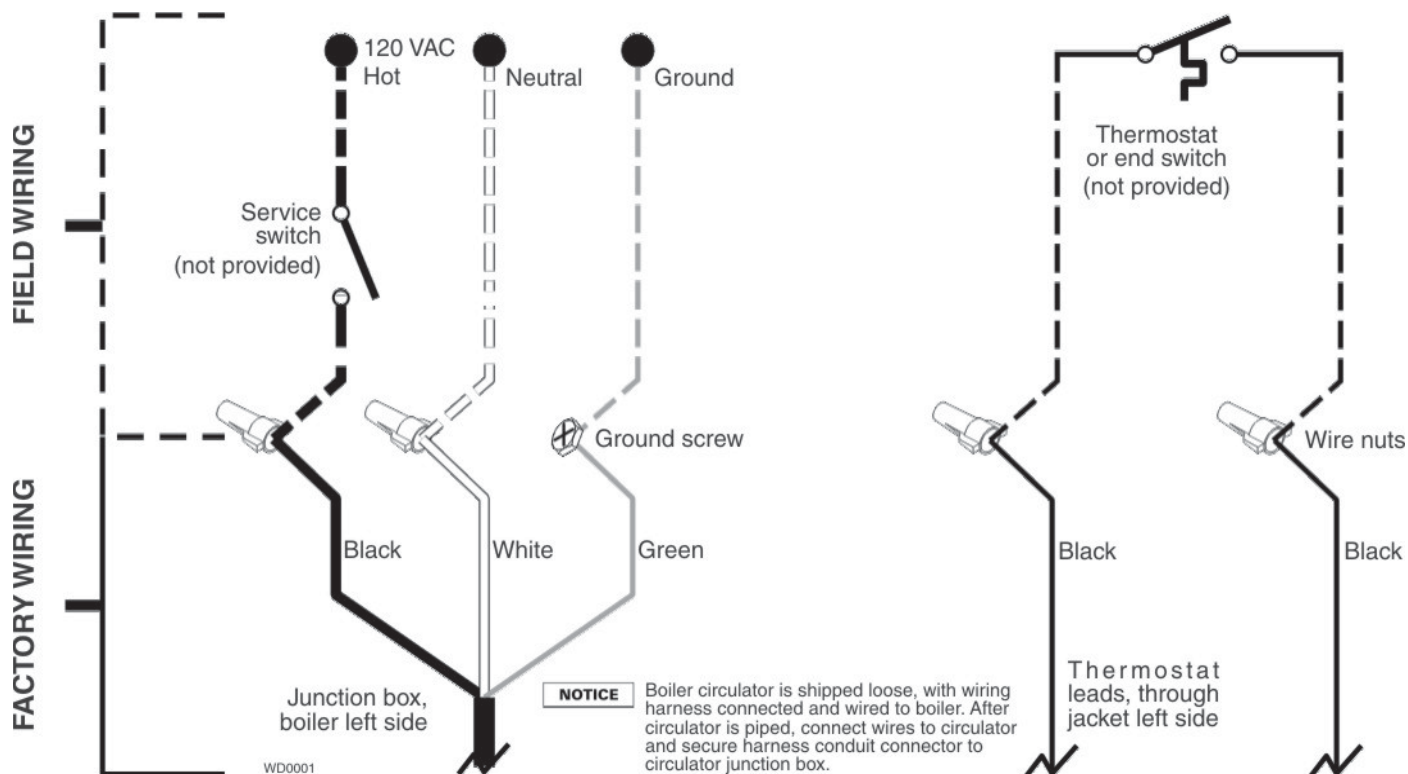
### Junction box (furnished)

1. Connect 120 VAC power wiring (Figure 15).
2. Fused disconnect or service switch (15 amp. recommended) may be mounted on this box. For those installations with local codes which prohibit installation of fused disconnect or service switch on boiler, install a 2 x 4 cover plate on the boiler junction box and mount the service switch remotely as required by the code.

### Wiring multiple zones

See zone valve manufacturer's literature for wiring and application. A separate transformer is required to power zone valves. Zoning with circulators requires a relay for each circulator.

**Figure 15** Field wiring connections — service switch and thermostat (or end switch) provided by installer



## 7 Start-up

### Preparation

#### Check for gas leaks

**WARNING** Before starting the boiler, and during initial operation, smell near the floor and around the boiler for gas odorant or any unusual odor. Do not proceed with start-up if there is any indication of a gas leak. Repair any leak at once.

**WARNING** Propane boilers only — Your propane supplier mixes an odorant with the propane to make its presence detectable. In some instances, the odorant can fade and the gas may no longer have an odor.

- Propane gas can accumulate at floor level. Smell near the floor for the gas odorant or any unusual odor. If you suspect a leak, do not attempt to light the pilot.
- Use caution when attempting to light the propane pilot. This should be done by a qualified service technician, particularly if pilot outages are common.
- Periodically check the odorant level of your gas.
- Inspect boiler and system at least yearly to make sure all gas piping is leak-tight.
- Consult your propane supplier regarding installation of a gas leak detector. There are some products on the market intended for this purpose. Your supplier may be able to suggest an appropriate device.

#### Determine if water treatment is needed

**DANGER** Do not use petroleum-based cleaning or sealing compounds in boiler system. Severe damage to boiler will occur, resulting in substantial property damage.

**WARNING** Eliminate all system leaks. Continual fresh makeup water will reduce boiler life. Minerals can build up in sections, reducing heat transfer, overheating cast iron, and causing section failure.

#### Verify water chemistry

Consult local water treatment companies for unusually hard water areas (above 7 grains hardness) or low pH water conditions (below 7.0). Boiler water pH of 7.0 to 8.5 is recommended.

#### Freeze protection (when used)

Use antifreeze made especially for hydronic systems. Inhibited propylene glycol is recommended.

**WARNING** Do not use ethylene glycol, automotive or undiluted antifreeze. Severe personal injury or death can result.

1. Determine antifreeze quantity according to system water content. Boiler water content is listed on page 39. Remember to include expansion tank water content.
2. Follow antifreeze manufacturer's instructions.
3. A 50% solution of propylene glycol/water provides maximum protection to about -30 °F.
4. Local codes may require back flow preventer or actual disconnect from city water supply.
5. When using antifreeze in a system with automatic fill, install a water meter to monitor water makeup. Glycol will leak before the water begins to leak, causing glycol level to drop. Added water will dilute the antifreeze, reducing the freeze protection level.

#### Fill the system with water

1. Close manual and automatic air vents and boiler drain cock.
2. Fill to correct system pressure. Correct pressure will vary with each application. Typical cold water fill pressure for a residential system is 12 psi.
3. Purge air from system:
  - a. Connect a hose to purge valve or valves, if installed. Route hose to an area where water can drain and be seen.
  - b. Close the boiler or system isolation valve between the purge valve and fill connection to the system.
  - c. Close zone isolation valves.
  - d. Open quick-fill valve on cold water makeup line.
  - e. Open purge valve.
  - f. One zone at a time, open the isolation valves. Allow water to run through the zone, pushing out the air. Run until no noticeable air flow is present. Close the zone isolation valves and proceed with the next zone. Follow this procedure until all zones are purged.
  - g. Close the quick-fill water valve and purge valve and remove the hose. Open all isolation valves. Watch that system pressure rises to correct cold-fill pressure.
  - h. After the system has operated for a while, eliminate any residual air by using the manual air vents located throughout the system.
  - i. If purge valves are not installed in system, open manual air vents in system one at a time, beginning with lowest floor. Close vent when water squirts out. Repeat with remaining vents.
4. Open automatic air vent (diaphragm-type or bladder-type expansion tank systems only) one turn.
5. Open other vents:
  - a. Starting on the lowest floor, open air vents one at a time until water squirts out.
  - b. Repeat with remaining vents.
6. Refill to correct pressure.

#### Inspect system water piping

After filling the boiler and system with water, inspect all piping throughout the system for leaks. If found, repair immediately. Repeat this inspection after the boiler has been started and the system has heated up.

**WARNING** Leaks must be repaired at once. Failure to do so can damage the boiler, resulting in substantial property damage.

**DANGER** Do not use petroleum-based cleaning or sealing compounds in boiler system. Severe damage to boiler will occur, resulting in substantial property damage.

#### Inspect base insulation

Check to make sure insulation is secure against all four sides of the base. If insulation is damaged or displaced, do not operate boiler. Replace or reposition insulation.

**WARNING** Failure to replace damaged insulation or reposition insulation can result in a fire hazard, causing severe personal injury, death or substantial property damage.

**WARNING** The boiler contains ceramic fiber and fiberglass materials. Use care when handling these materials per instructions on page 40 of this manual. Failure to comply could result in severe personal injury.

## 7 Start-up continued

### Operate boiler

- WARNING** DO NOT proceed with boiler operation unless boiler and system have been filled with water and all instructions and procedures of previous manual sections have been completed. Failure to do so could result in severe personal injury, death or substantial property damage. Before starting the boiler . . .
- Read manual Sections 9 and 10 and the “Operating instructions”, page 23.
  - Verify the boiler and system are full of water.
  - Verify the Start-up “Preparation” procedures of this section have been completed.

### Start the boiler

Follow the “Operating instructions”, page 23.

If boiler fails to start, see “If boiler doesn’t start . . . Check for:” on this page.

### Check system and boiler

- WARNING** Eliminate all system leaks. Continual fresh makeup water will reduce boiler life. Minerals can build up in sections, reducing heat transfer, overheating cast iron, and causing section failure.

- WARNING** If you discover evidence of any gas leak, shut down the boiler at once. Find the leak source with bubble test and repair immediately. Do not start boiler again until corrected. Failure to comply could result in severe personal injury, death or substantial property damage.

- DANGER** Do not use petroleum-based cleaning or sealing compounds in boiler system. Severe damage to boiler will occur, resulting in substantial property damage.

1. Check system piping for leaks. If found, shut down boiler and repair immediately.
2. Vent air from system using manual vents. Air in the system will interfere with circulation and cause heat distribution problems and noise.
3. Inspect vent system thoroughly for signs of deterioration from corrosion, physical damage or sagging. Verify that masonry chimney liners are in good condition, with no obstructions, and there are no openings into the chimney.
4. Check around the boiler for gas odor following the procedure of page 17 of this manual.
5. Verify operation using procedures below. Perform “Checkout procedure” on page 20 and fill in the “Installation and service certificate”.

### If boiler doesn’t start . . . Check for:

1. Loose connections, blown fuse or service switch off?
2. High limit switch set below boiler water temperature?
3. Thermostat set below room temperature?
4. Gas not turned on at meter or boiler?
5. Incoming gas pressure less than:  
5" w.c. for natural gas? 11" w.c. for propane gas?
6. If none of the above corrects the problem, see “Troubleshooting”, page 28 of this manual.

### Verify operation

#### Check burner flame — Pilot burner

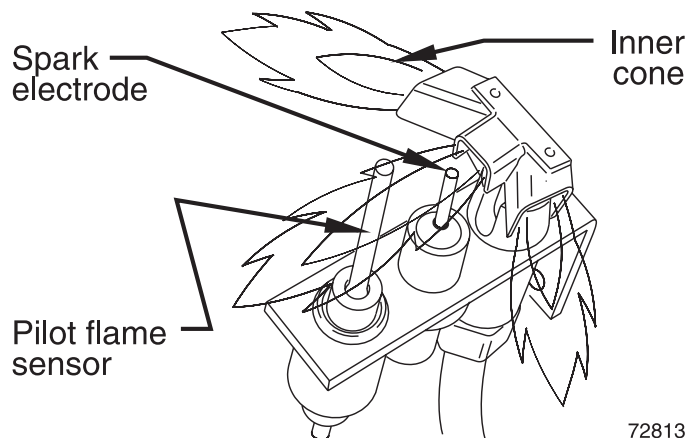
##### Proper pilot flame (see Figure 16):

1. Blue flame.
2. Inner cone engulfing pilot flame sensor.
3. Pilot flame sensor glowing cherry red.

##### Improper pilot flame:

1. Overfired — Large flame lifting or blowing past pilot flame sensor.
2. Underfired — Small flame. Inner cone not engulfing pilot flame sensor.
3. Lack of primary air — Yellow flame tip.
4. Incorrectly heated pilot flame sensor.

Figure 16 Typical pilot burner flame



#### Check burner flames — Main burner

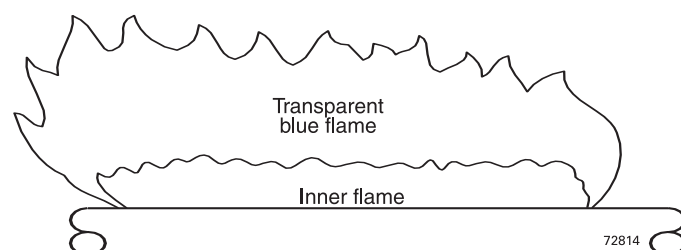
##### Proper main burner flame (see Figure 17):

1. Yellow-orange streaks may appear (caused by dust).

##### Improper main burner flame:

1. Overfired — Large flames.
2. Underfired — Small flames.
3. Lack of primary air — Yellow tipping on flames (sooting will occur).

Figure 17 Typical main burner flame



## 8 Checkout procedure

- Boiler and heat distribution units filled with water?
- Automatic air vent, if used, open one full turn?
- Air purged from system?
- Air purged from gas piping? Piping checked for leaks?
- Correctly-sized manifold orifices installed? See Table 3, page 6 to check size and fuel type.

**DANGER**

Correctly sized manifold orifices must be used. Failure to do so will cause severe personal injury, death or substantial property damage.

- Followed “Operating instructions” on boiler or in manual, page 23 for proper start-up?
- Proper burner flame observed? See “Verify operation”, manual Section 7, page 19.
- Test limit control — While burners are operating, move indicator on limit control below actual boiler water temperature. Burners should go off while circulator continues to operate. Raise setting on limit control above boiler water temperature and burners should reignite.
- Test additional field-installed controls — If boiler has a low water cutoff, additional high limit or other controls, test for operation as outlined by manufacturer. Burners should be operating and should go off when controls are tested. When controls are restored, burners should reignite.
- Test ignition system safety device:
  - a. Connect manometer to outlet side of gas valve. Start boiler, allowing for normal start-up cycle to occur and main burners to ignite. With main burners on, manually shut off gas supply at manual main shutoff gas valve. Burners should go off. Open manual main shutoff gas valve. Manometer should confirm there is no gas flow. Pilot will relight, flame sensing element will sense pilot flame and main burners reignite.
- Set limit control(s) to system temperature requirements. Adjust

balancing valves and controls to provide design temperature to system.

- For multiple zones, adjust flow so it is about the same in each zone.
- Verify thermostat heat anticipator (if available) set properly? See wiring diagram label on boiler or in manual, page 22.
- Cycle boiler with thermostat — Raise to highest setting and verify boiler goes through normal start-up cycle. Lower to lowest setting and verify boiler goes off.
- Measure natural gas input:
  - a. Operate boiler 10 minutes.
  - b. Turn off other appliances.
  - c. At natural gas meter, measure time (in seconds) required to use one cubic foot of gas.
  - d. Calculate gas input:
 
$$\frac{3600 \times 1000}{\text{number of seconds from step c}} = \text{Btuh}$$
  - e. Btuh calculated should approximate input rating on boiler rating label.
- Check manifold gas pressure by connecting manometer to downstream test tapping on main gas valve. Manifold pressure for natural gas should be 3.5" w.c. and for propane gas should be 10" w.c.
- Observe several operating cycles for proper operation.
- Set room thermostat to desired room temperature.
- Fill in “Installation and service certificate” below?
- Review all instructions shipped with this boiler with owner or maintenance person. Return instructions to envelope and give to owner or place in pocket inside front panel in boiler.

### Installation and service certificate

**Boiler model** \_\_\_\_\_ **Series** \_\_\_\_\_

**CP number** \_\_\_\_\_ **Date installed** \_\_\_\_\_

**Measured Btuh input** \_\_\_\_\_

- Installation instructions have been followed.**
- Checkout sequence has been performed.**
- Above information is certified to be correct.**
- Information received and left with owner/maintenance person.**

**Installer** \_\_\_\_\_ (company) \_\_\_\_\_ (address) \_\_\_\_\_ (phone)

\_\_\_\_\_  
(installer's signature)

## 9 Sequence of operation

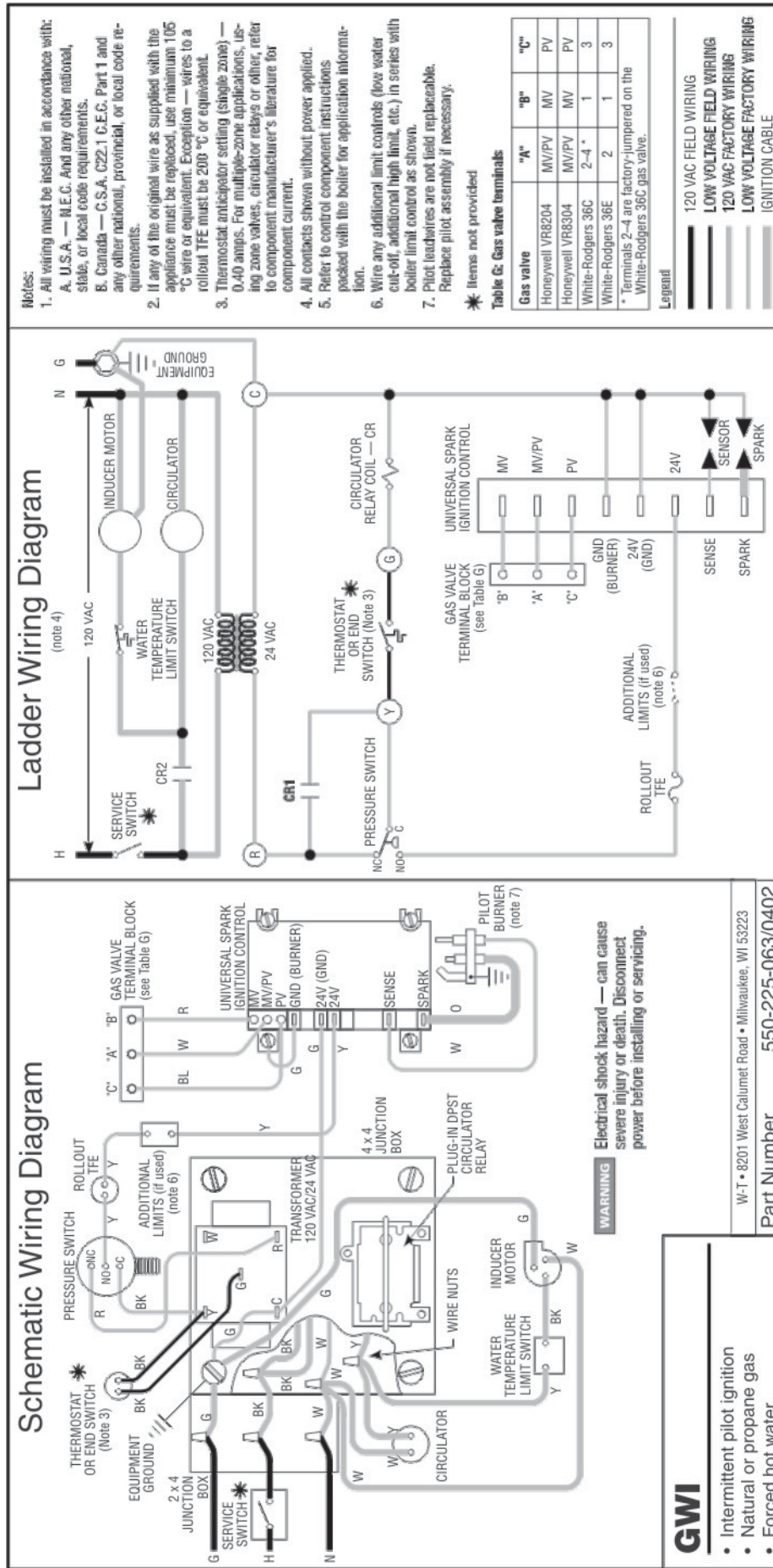
**WARNING**

Follow all procedures given in this manual and “Operating Instructions” when operating the boiler. Failure to do so could result in severe personal injury, death or substantial property damage.

1. See page 23 (or boiler “Operating Instructions” label) for “Operating Instructions.”
2. Raise room thermostat to call for heat.
3. Blower and circulator energize. After pressure switch proves airflow, ignition control starts a 30-second prepurge.
4. Ignition control sparks the pilot and opens pilot gas valve (in main gas valve body).
5. Flame-proving period starts:
  - a. If pilot does not light and prove within 15 seconds, pilot gas valve closes and spark stops. Ignition control waits 5 to 6 minutes, with blower and circulator continuing to run. After wait period, ignition control will attempt to light the pilot again.
  - b. If pilot ignition and proving is successful, ignition control turns off spark and opens the main gas valve, starting main burner operation.
6. During main burner operation:
  - a. Ignition control monitors pilot flame. If signal is lost, main gas valve closes and spark starts. Ignition controls starts a flame-proving cycle as in step 5, above.
  - b. If power is interrupted, main and pilot gas valves close. Ignition control will start again at step 3, left, when power is restored.
7. When the water temperature limit switch opens, the blower shuts off, causing the pressure switch to open. The ignition control then closes the main gas valve. The circulator continues to run.
8. When the thermostat opens (demand satisfied), the ignition control closes pilot and main gas valves. Blower and circulator shut down.
9. Boiler is now in the off (stand-by) cycle.
10. Repeat steps 1 through 7 several times to verify controls are operating correctly.
11. Return thermostat(s) to normal setting.
12. Set the thermostat heat anticipator as instructed in the wiring diagram (and on boiler wiring diagram label).

# 9 Sequence of operation continued

**Figure 18** Wiring diagram — GWI boilers



# 10 Operating instructions

## FOR YOUR SAFETY READ BEFORE OPERATING

**WARNING** If you do not follow these instructions exactly, a fire or explosion may result causing property damage, personal injury or loss of life.

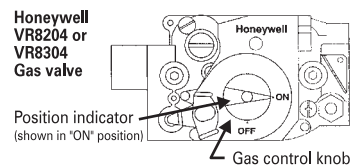
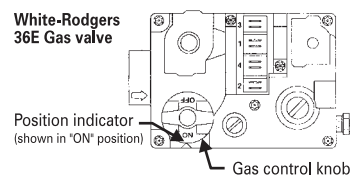
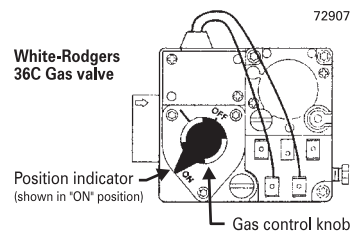
- |   |  |
|---|--|
| <p>A. This appliance is equipped with an ignition device which automatically lights the pilot. <b>Do not</b> try to light the pilot by hand.</p> <p>B. Before <b>OPERATING</b>, smell all around the appliance area for gas. Be sure to smell next to the floor because some gas is heavier than air and will settle on the floor. See below.</p> | <p>C. Use only your hand to depress or move the selector arm. Never use tools. If the selector arm will not depress or move by hand, don't try to repair it, call a qualified service technician. Force or attempted repair may result in a fire or explosion.</p> <p>D. Do not use this appliance if any part has been under water. Immediately call a qualified service technician to inspect the appliance and to replace any part of the control system and any gas control, which has been under water.</p> |
|---|--|

### WHAT TO DO IF YOU SMELL GAS

- |  |   |
|--|---|
| <ul style="list-style-type: none"> <li>• Do not try to light any appliance.</li> <li>• Do not touch any electric switch; do not use any phone in your building.</li> </ul> | <ul style="list-style-type: none"> <li>• Immediately call your gas supplier from a neighbor's phone. Follow the gas supplier's instructions.</li> <li>• If you cannot reach your gas supplier, call the fire department.</li> </ul> |
|--|---|

## OPERATING INSTRUCTIONS

1. **STOP!** Read the safety information above on this label.
2. Set the thermostat to lowest setting.
3. Turn off all electrical power to the appliance.
4. Remove jacket front panel.
5. This appliance is equipped with an ignition device which automatically lights the burner. Do not try to light the burner by hand.
6. Turn **Gas control knob** clockwise ↻ to **OFF**.
7. Wait five (5) minutes to clear out any gas. Then smell for gas, including near the floor. If you smell gas, **STOP!** Follow "B" in the safety information above. If you don't smell gas, go to the next step.
8. Turn **Gas control knob** counterclockwise ↺ to **ON**.
9. Turn on all electric power to the appliance.
10. Set thermostat to desired setting.
11. If the appliance will not operate, follow the instructions "**TO TURN OFF GAS TO APPLIANCE**" below and call your service technician or gas supplier.
12. Replace jacket front panel.



## TO TURN OFF GAS TO THE APPLIANCE

- |  |   |
|--|---|
| <ol style="list-style-type: none"> <li>1. Set the thermostat to lowest setting.</li> <li>2. Turn off all electric power to the appliance if service is to be performed.</li> </ol> | <ol style="list-style-type: none"> <li>3. Remove jacket front panel.</li> <li>4. Turn <b>Gas control knob</b> clockwise ↻ to <b>OFF</b>. Do not force.</li> <li>5. Replace jacket front panel.</li> </ol> |
|--|---|

# 11 Service and maintenance

**Table 8** Service and maintenance schedules (service technician and user)

| <b>Service technician</b><br>(see following pages for instructions)   | <b>Owner maintenance</b><br>(see User’s Information Manual for instructions)   |
|---|--|
| ANNUAL START-UP   | <input type="checkbox"/> <b>Daily</b> <ul style="list-style-type: none"> <li>• Check boiler area</li> <li>• Check boiler pressure/temperature gauge</li> <li>• Check air openings</li> </ul>   |
|   | <input type="checkbox"/> <b>Monthly</b> <ul style="list-style-type: none"> <li>• Check boiler piping</li> <li>• Check venting system</li> <li>• Check condensate drain system</li> <li>• Check boiler relief valve</li> <li>• Check automatic air vents (if used)</li> <li>• Check pilot and main burner flames</li> <li>• Check and clean vent termination (side-wall-vented boilers only)</li> </ul> |
|   | <input type="checkbox"/> <b>Periodically</b> <ul style="list-style-type: none"> <li>• Test low water cutoff (if used)</li> <li>• Oil inducer motor</li> </ul>  |
|   | <input type="checkbox"/> <b>Every 6 months</b> <ul style="list-style-type: none"> <li>• Operate relief valve</li> </ul>  |
|   | <input type="checkbox"/> <b>End of season</b> <ul style="list-style-type: none"> <li>• Shut down procedure</li> </ul>  |
| <input type="checkbox"/> <b>Inspect:</b> <ul style="list-style-type: none"> <li>• Reported problems</li> <li>• Boiler area</li> <li>• Air openings</li> <li>• Flue gas vent system</li> <li>• Pilot and main burner flames</li> <li>• Water piping</li> <li>• Boiler heating surfaces</li> <li>• Burners and base</li> <li>• Condensate drain system</li> </ul> |  |
| <input type="checkbox"/> <b>Service:</b> <ul style="list-style-type: none"> <li>• Inducer motor</li> <li>• Oiled-bearing circulators</li> </ul>   |  |
| <input type="checkbox"/> <b>Start-up:</b> <ul style="list-style-type: none"> <li>• Perform start-up per manual</li> </ul>   |  |
| <input type="checkbox"/> <b>Check/test:</b> <ul style="list-style-type: none"> <li>• Gas piping</li> <li>• Cold fill and operating pressures</li> <li>• Air vents and air elimination</li> <li>• Limit controls and cutoffs</li> <li>• Expansion tank</li> <li>• Boiler relief valve</li> </ul>   |  |
| <input type="checkbox"/> <b>Review:</b> <ul style="list-style-type: none"> <li>• Review with owner</li> </ul>   |  |
| <input type="checkbox"/> <b>Cleaning boiler heating surfaces</b>  |  |

**WARNING** Follow the “Service and maintenance” procedures given throughout this manual and in component literature shipped with the boiler. See “Read this first” on page 2. Failure to perform the service and maintenance could result in damage to the boiler or system. Failure to follow the directions in this manual and component literature could result in severe personal injury, death or substantial property damage.

**WARNING** The boiler should be inspected and started annually, at the beginning of the heating season, only by a qualified service technician. In addition, the maintenance and care of the boiler designated in Table 8, page 24, and explained on the following pages must be performed to assure maximum boiler efficiency and reliability. Failure to service and maintain the boiler and system could cause equipment failure resulting in severe personal injury, death or substantial property damage.



# 11 Service and maintenance continued

**WARNING** The boiler contains ceramic fiber and fiberglass materials. Use care when handling these materials per instructions on page 40 of this manual. Failure to comply could result in severe personal injury.

## □ Inspect

### Reported problems

Inspect any problems reported by owner and correct before proceeding.

### Boiler area

1. Verify that boiler area is free of any combustible materials, gasoline and other flammable vapors and liquids.
2. Verify that boiler area (and air intake) is free of any of the contaminants listed in Table 2 on page 5 of this manual. If any of these are present in the boiler intake air vicinity, they must be removed. If they cannot be removed, install combustion air piping to the boiler in accordance with national, provincial or local codes.

### Air openings

1. Verify that combustion and ventilation air openings to the boiler room and/or building are open and unobstructed. Check operation and wiring of automatic combustion air dampers, if used.
2. Verify that boiler vent discharge and air intake are clean and free of obstructions.

### Flue gas vent system

1. Visually inspect entire flue gas venting system for blockage, deterioration or leakage. Repair any joints that show signs of leakage in accordance with vent manufacturer's instructions.
2. Verify that masonry chimneys are lined, lining is in good condition, and there are not openings into the chimney.

**WARNING** Failure to inspect for the above conditions and have them repaired can result in severe personal injury or death.

### Pilot and main burner flames

1. Visually inspect pilot burner and main burner flames as directed under Section 7, page 19 of this manual.

### Water piping

1. Check the boiler interior piping and all system piping for signs of leaks.
2. Repair any leaks before proceeding.

**WARNING** Electrical shock hazard — Turn off power to the boiler before any service operation on the boiler except as noted otherwise in this instruction manual. Failure to turn off electrical power could result in electrical shock, causing severe personal injury or death.

**DANGER** Do not use petroleum-based cleaning or sealing compounds in boiler system. Severe damage to boiler will occur, resulting in substantial property damage.

**WARNING** Eliminate all system or boiler leaks. Continual fresh makeup water will reduce boiler life. Minerals can build up in sections, reducing heat transfer, overheating cast iron, and causing section failure. Leaking water may also cause severe property damage.

## □ Inspect

### Boiler heating surfaces

1. Disconnect the vent pipe at the boiler inducer outlet connection after turning off power to the boiler.
2. Use a bright light to inspect the flue pipe interior and inducer interior.
3. Inspect the boiler vent outlet area and heating surfaces by looking through the opening.
4. If the vent pipe or inducer interior show evidence of soot, follow "Cleaning boiler heating surfaces", page 27, to remove the flue collector and clean the boiler if necessary after close inspection of boiler heating surfaces. If there is evidence of rusty scale deposits, check the water piping and control system to make sure the boiler return water temperature is properly maintained (per this manual).
5. Reconnect vent to inducer outlet (seal joint per page 8) and replace all boiler components before returning to service.
6. Check inside and around boiler for evidence of any leaks from the boiler. If found, locate source of leaks and repair.

### Burners and base

1. After turning off power to the boiler, remove the jacket door and base access panel (Figure 21, item 4, page 34).
2. Inspect burners and all other components in the boiler base.
3. If burners must be cleaned, raise rear of each burner to release from support slot, slide forward and remove. Then brush and vacuum the burners thoroughly, making sure all ports are free of debris. Carefully replace all burners, making sure burner with pilot bracket is replaced in its original position and all burners are upright (ports up).
4. Inspect the base insulation.
  - a. Verify that the insulation is intact and secure against all four sides of the base.

**WARNING** If insulation is damaged or displaced, do not operate the boiler. Replace or reposition insulation as necessary. Failure to replace damaged insulation can result in a fire hazard, causing severe personal injury, death or substantial property damage.

### Condensate drain system

1. If vent system is equipped with a condensate drain, check the hose and connections for tightness.
2. Verify the hose is unobstructed and in good condition and that condensate can flow freely. Replace hose if necessary.

# 11 Service and maintenance continued

## □ Service

### Inducer motor

1. With boiler power **OFF**, place a few drops of S.A.E. 20 motor oil in each of the two motor oiling cups.

**WARNING** Use only S.A.E. 20 motor oil to lubricate inducer motor. Do not use universal household oils. Motor could be damaged, resulting possible severe property damage.

### Oiled-bearing circulators

1. The circulator shipped with the GWI boiler is water-lubricated. No oiling is required.
2. Check other circulators in the system. Oil any circulators requiring oil, following circulator manufacturer's instructions. Over-oiling will damage the circulator.

## □ Start-up

1. Perform start-up procedures of Section 7, pages 18–19, including procedure to verify operation of burners on page 19.
2. Verify cold fill pressure is correct and that fill system is working properly.
3. Verify antifreeze level (if used) is at the right concentration and that inhibitor level is correct.
4. Check gas piping, per manual Sections 5 and 7, verifying no indications of leakage and all piping and connections are in good condition.
5. Read the “Operating instructions” (page 23).
6. Start the boiler following the “Operating instructions” (page 23).

## □ Check/test

### Gas piping

1. Sniff near floor and around boiler area for any indication of a gas leak.
2. Test gas piping using bubble test, per Section 5, page 16 of this manual, if there is any indication of a leak.

### Cold fill and operating pressures

1. While the system is cold, note the pressure reading on the boiler pressure/temperature gauge. Verify that cold fill pressure is correct.
2. Watch the pressure as the boiler and system heat up to ensure pressure rise is normal. Too high a rise would indicate a waterlogged or undersized expansion tank.

### Air vents and air elimination

1. Inspect automatic air vents (if used). Also inspect air separators to ensure they are operational.
2. The cap must be unscrewed one turn to allow air to escape.

## □ Check/test

3. If the air vent is leaking, remove cap and briefly push valve — then release to clean the valve seat.
4. Replace cap by twisting all the way onto valve and then unscrewing one turn.

### Limit controls and cutoffs

1. Inspect and test the boiler limit control. Verify operation by turning control set point below boiler temperature. Boiler should cycle off. Return dial to original setting.
2. Inspect and test additional limit controls or low water cutoffs installed on system.

### Expansion tank

1. Expansion tanks provide space for water to move in and out as the heating system water expands due to temperature increase or contracts as the water cools. Tanks may be open, closed or diaphragm or bladder type. See Section 4, page 13 of this manual for suggested locations of expansion tanks and air eliminators.

Open-type — located above highest radiator or baseboard unit, usually in the attic or closet. Has a gauge glass and overflow pipe to a drain.

Closed-type — welded gas tight and located above boiler. Tank is partially filled with water, leaving an air cushion for expansion.

- Make sure this type of tank is fitted with a tank fitting, such as the B & G Tank-Trol or Taco Taco-Trol. This fitting reduces gravity circulation of air-saturated tank water back to the system and prevents the air from bubbling up through the water as it returns from the system.
- Do not use automatic air vents in systems with closed-type tanks. The air will escape from the system instead of returning to the tank. Eventually, the tank will waterlog and no longer control pressurization. The boiler relief valve will weep frequently.

Diaphragm- or bladder-type — welded gas tight with a rubber membrane to separate the tank pressurizing air and the water. May be located at any point in the system, but most often found near the boiler.

- Systems with this type of expansion tank require at least one automatic air vent, preferably located on top of an air eliminator, as shown in examples in manual Section 4, page 13.
2. If relief valve has tended to weep frequently, the expansion tank may be waterlogged or undersized.

Closed-type tank — tank is most likely waterlogged. Install a tank fitting if not already installed. Then check fill level per fitting manufacturer's instructions. If fill level is correct, check tank size against manufacturer's instructions. Replace with a larger tank if necessary.

Diaphragm- or bladder-type — first, check tank size to be sure it is large enough for the system. If size is too small, add additional tank(s) as necessary to provide sufficient expansion. If tank size is large enough, remove tank from system and check charge pressure (usually 12 psig for residential applications). If tank won't hold pressure, membrane has been damaged. Replace tank.

# 11 Service and maintenance continued

## □ Check/test

### Boiler relief valve

1. Inspect the relief valve and lift the lever to verify flow as in the following warnings, excerpted from a relief valve manufacturer's warning label. Before operating any relief valve, ensure that it is piped with its discharge in a safe area to avoid severe scald potential. Read manual Section 4, page 13, before proceeding further.

**WARNING** Safety relief valves should be reinspected AT LEAST ONCE EVERY THREE YEARS, by a licensed plumbing contractor or authorized inspection agency, to ensure that the product has not been affected by corrosive water conditions and to ensure that the valve and discharge line have not been altered or tampered with illegally. Certain naturally occurring conditions may corrode the valve or its components over time, rendering the valve inoperative. Such conditions are not detectable unless the valve and its components are physically removed and inspected. This inspection must only be conducted by a plumbing contractor or authorized inspection agency — not by the owner. Failure to reinspect the boiler relief valve as directed could result in unsafe pressure buildup, which can result in severe personal injury, death or substantial property damage.

2. After following the above warning directions, if the relief valve weeps or will not seat properly, replace the relief valve. Ensure that the reason for relief valve weeping is the valve and not over-pressurization of the system due to expansion tank waterlogging or undersizing.

**WARNING** Following installation, the valve lever must be operated AT LEAST ONCE A YEAR to ensure that waterways are clear. Certain naturally occurring mineral deposits may adhere to the valve, rendering it inoperative. When manually operating the lever, water will discharge and precautions must be taken to avoid contact with hot water and to avoid water damage. Before operating lever, check to see that a discharge line is connected to this valve directing the flow of hot water from the valve to a proper place of disposal otherwise severe personal injury may result. If no water flows, valve is inoperative. Shut down boiler until a new relief valve has been installed.

## □ Review with owner

1. Review the User's Information Manual with the owner.
2. Emphasize the need to perform the maintenance schedule specified in the User's Information Manual (and in this manual as well).
3. Remind the owner of the need to call in a licensed contractor should the boiler or system exhibit any unusual behavior.
4. Remind the owner to follow the proper shutdown procedure and to schedule an annual start-up at the beginning of the next heating season.

## □ Cleaning boiler heating surfaces

**WARNING** The boiler contains ceramic fiber and fiberglass materials. Use care when handling these materials per instructions on page 40 of this manual. Failure to comply could result in severe personal injury.

1. Shut down boiler:
  - Follow "To Turn Off Gas to Appliance" instructions on boiler and "Operating instructions".
  - Do not drain boiler unless it will be exposed to freezing temperatures. If using antifreeze in system, do not drain.
2. Follow shutdown procedure.
3. Remove venting system connection to boiler.
4. Remove top jacket panel. Turn back insulation.
5. Remove collector box/transition assembly. Clean sealant from assembly and sections.
6. Remove radiation plates hanging between sections.
7. Remove burners from base. Brush and vacuum burners to remove all dust and lint. Verify that all burner ports are free of debris.
8. Place newspapers in base of boiler to collect soot.
9. Clean between sections with wire flue brush.
10. Remove newspaper and soot. Vacuum or brush base and surrounding area.
11. Reinstall radiation plates.
12. Replace collector box/transition assembly. Seal with sealant. Obtain gas-tight seal to prevent flue gas spillage and carbon monoxide emissions, resulting in severe personal injury or death.
13. Replace insulation and jacket top panel.
14. Start up boiler following pages 18 –19 of this manual and the boiler "Operating Instructions". Excessive sooting indicates improper gas combustion. If found check for proper combustion and make any necessary adjustments.

# 12 Troubleshooting

**WARNING** Label all wires prior to disconnection when servicing controls. Wiring errors can cause improper and dangerous operation.

**WARNING** Never jumper (bypass) rollout thermal fuse element or any other device except for momentary testing as outlined in “Troubleshooting” charts, pages 29–32. Severe personal injury, death or substantial property damage can result.

**WARNING** Burner access panel must be in position during boiler operation to prevent momentary flame rollout on ignition of main flame. Severe personal injury or substantial property damage will result.

### Before troubleshooting:

1. Have the following items:
  - a. Voltmeter that can check 120 VAC and 24 VAC.
  - b. Microammeter with a minimum scale range of 0-25.
  - c. Continuity checker.
  - d. U-tube manometer
  - e. Inclined manometer with 0 – 2" w.c. range.
2. Check for 120 VAC (minimum 102 VAC to maximum 132 VAC) to boiler.
3. Make sure thermostat is calling for heat and contacts (including appropriate zone controls) are closed. Check for 24 VAC between thermostat wire nuts and ground.

### Check the following:

1. Wire connectors to control module are securely plugged in at module and originating control.
2. Gas pressures (connect U-tube manometer at gas valve tapings):
  - a. With boiler off — 13" w.c. maximum natural or propane gas pressure upstream of gas valve.
  - b. With boiler on:
    - 5" w.c. minimum natural gas pressure or 11" w.c. propane gas pressure upstream of gas valve.
    - 3.5" w.c. minimum natural gas pressure or 10" w.c. propane gas pressure downstream tapping on gas valve — Can be adjusted by regulator on gas valve.

### How to check pressure switch setting (if specified in Troubleshooting charts)

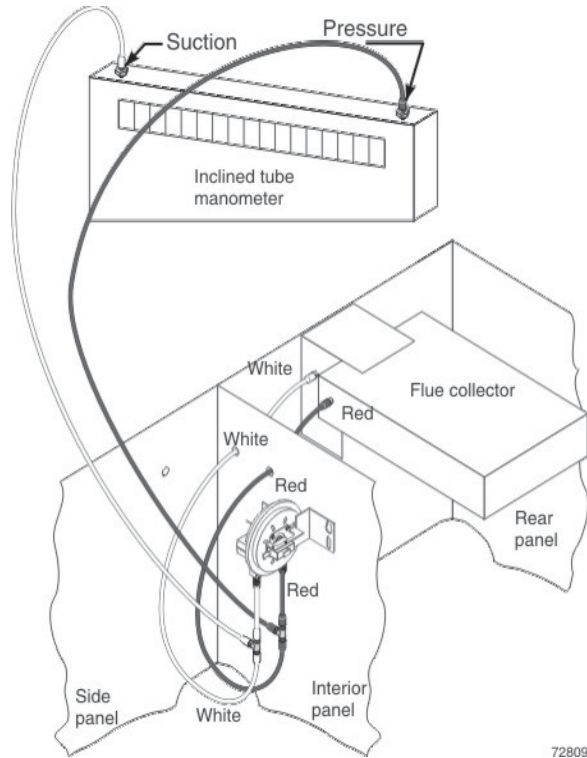
**NOTICE** Make sure boiler water temperature is 100 °F or cooler before starting procedure to obtain appropriate readings.

1. See Figure 19 and Table 9.
2. Remove both air pressure switch hoses from air pressure switch.
3. Install tees and tubing as shown in Figure 19 to inclined manometer.
4. Turn off gas valve and set thermostat to call for heat. Inducer will run but burners will not ignite.
5. Check for 24 VAC between both air pressure switch terminals.
6. If manometer reading is above the setpoint of the switch (see Table 9), but there is not 24 VAC between air pressure switch terminals “C” and “NO” — replace air pressure switch.

### Troubleshooting air pressure reading

1. If manometer reading is lower than the setpoint of the switch

**Figure 19** Checking pressure switch



(see Table 9) — check for possible causes:

- blockage in hoses
- obstruction in inducer housing outlet
- loose inducer wheel on motor shaft
- inducer motor not in proper rpm
- inducer back plate not sealed properly
- blockage in block assembly
- blockage in flue pipe or termination
- incorrect pressure switch

### Return to normal operation

When pressure reading is correct and air pressure switch is operating properly — remove tees and reinstall hoses to air pressure switch.

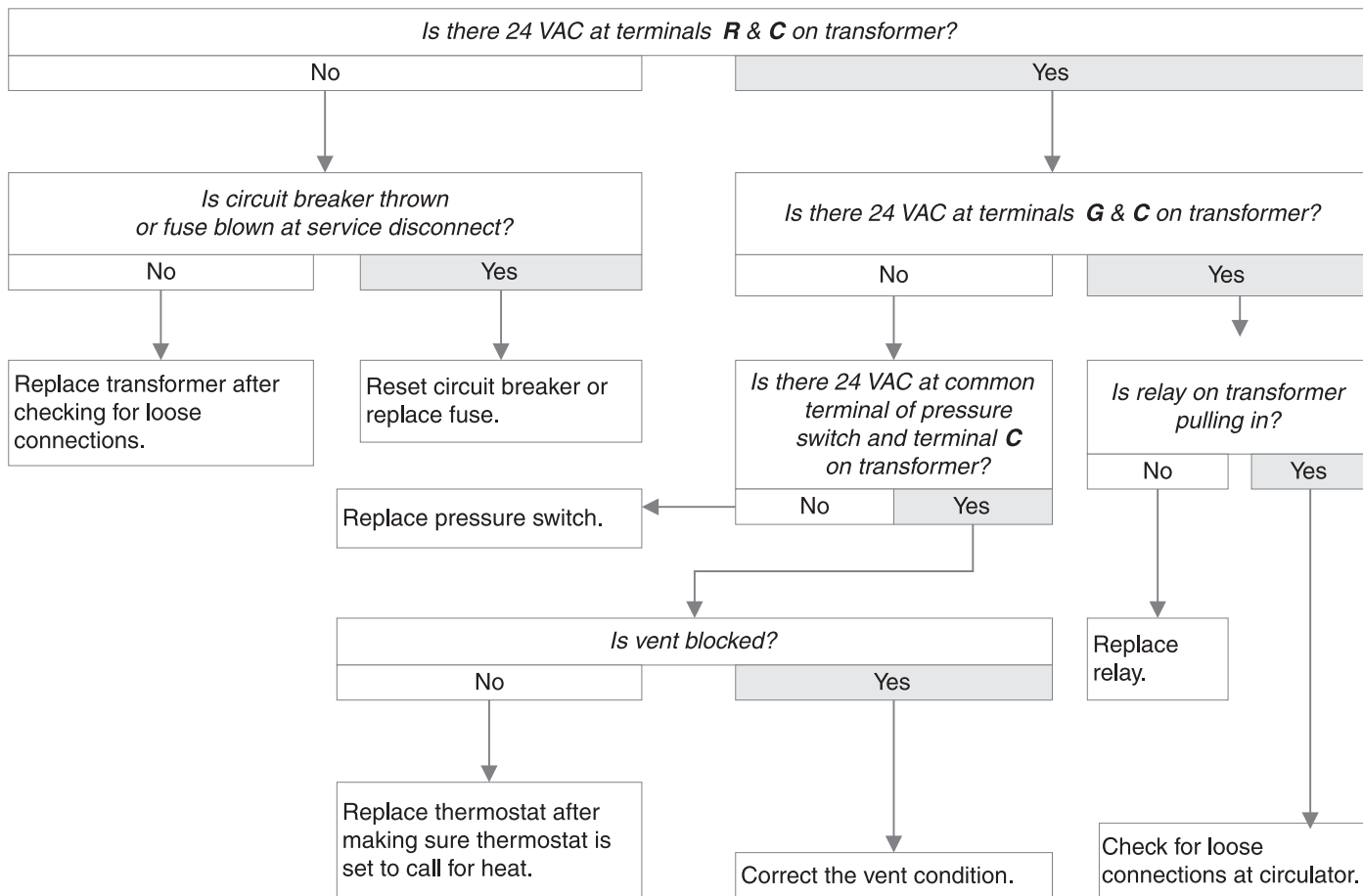
**NOTICE** The boiler will not operate correctly unless pressure switch hoses are correctly located. The red hose connects from the right side (negative) hose barb to the flue collector. The white hose connects from the left side (positive) hose barb of the switch to the connector box (between flue collector and inducer) as shown in Figure 19.

**Table 9** Pressure switch setpoint (for elevations above 2,000 ft, contact your local supplier for details.)

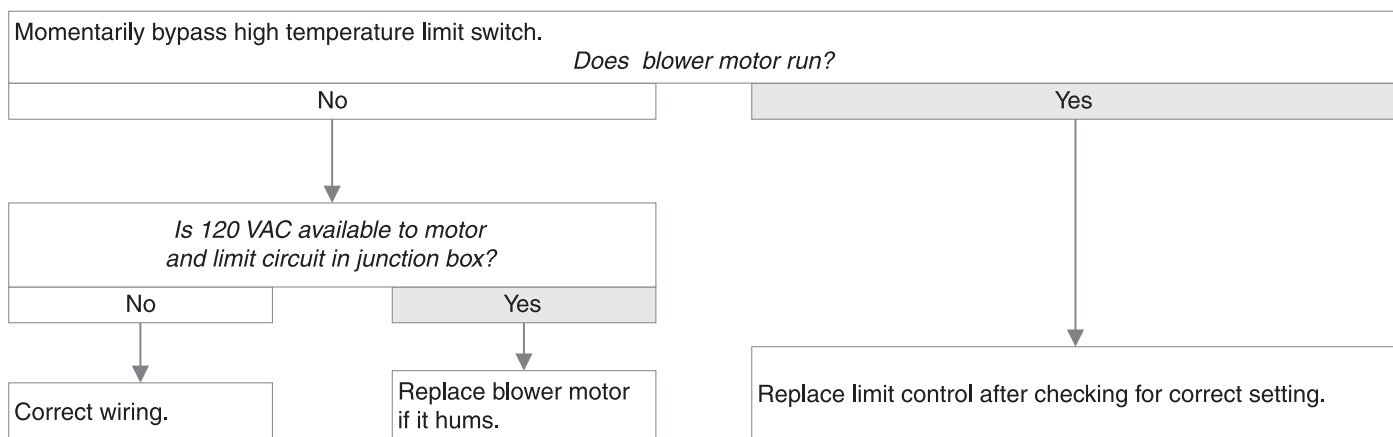
| Boiler model number        | Inches W.C. |
|----------------------------|-------------|
| <b>GWI-047 and GWI-063</b> | 1.19        |
| <b>GWI-095</b>             | 1.08        |
| <b>GWI-127</b>             | 0.86        |
| <b>GWI-158</b>             | 0.61        |
| <b>GWI-190</b>             | 0.76        |

# 12 Troubleshooting continued

**CHART 1 Blower and circulator will not operate**

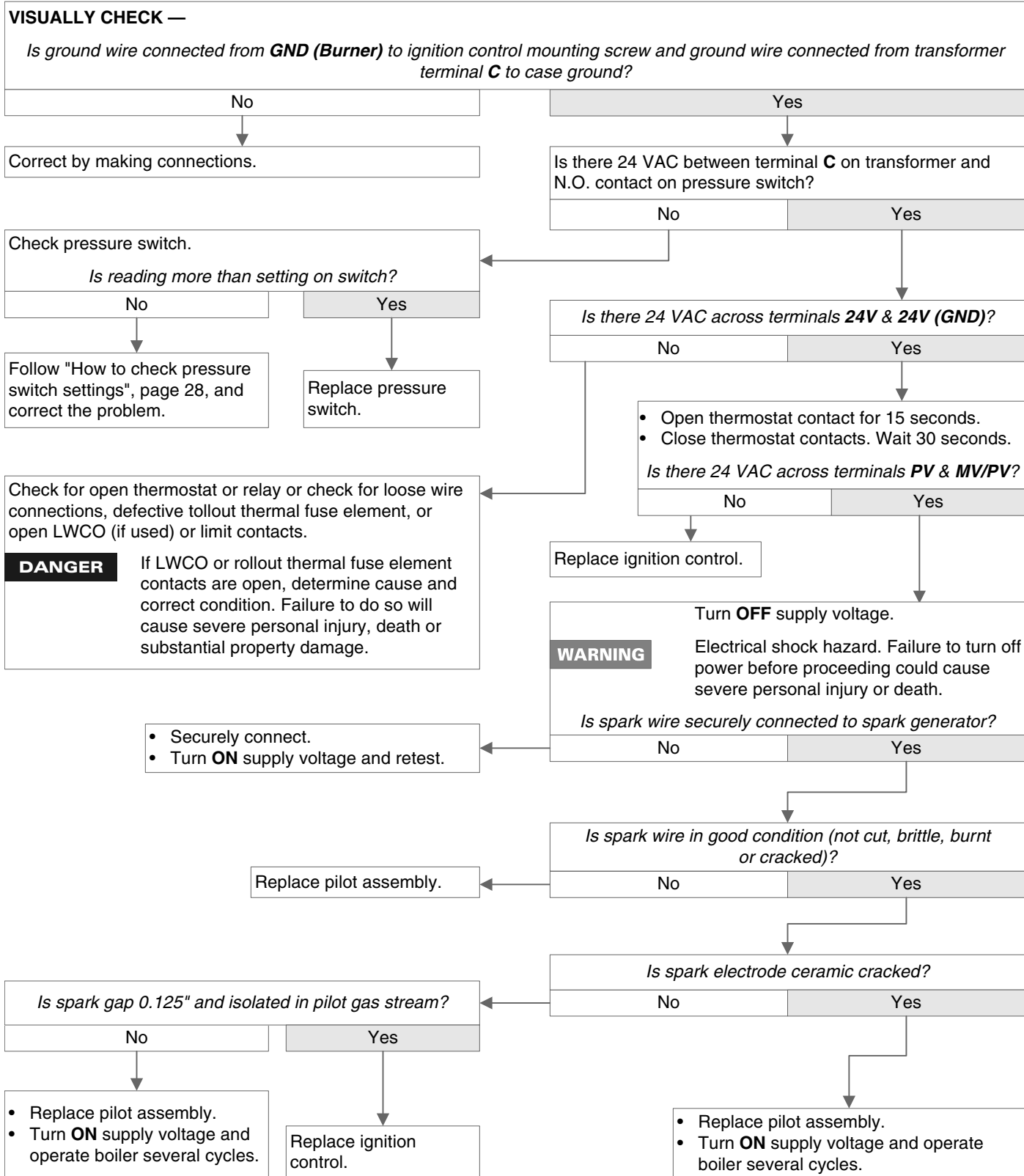


**CHART 2 Blower will not operate but circulator does operate.**



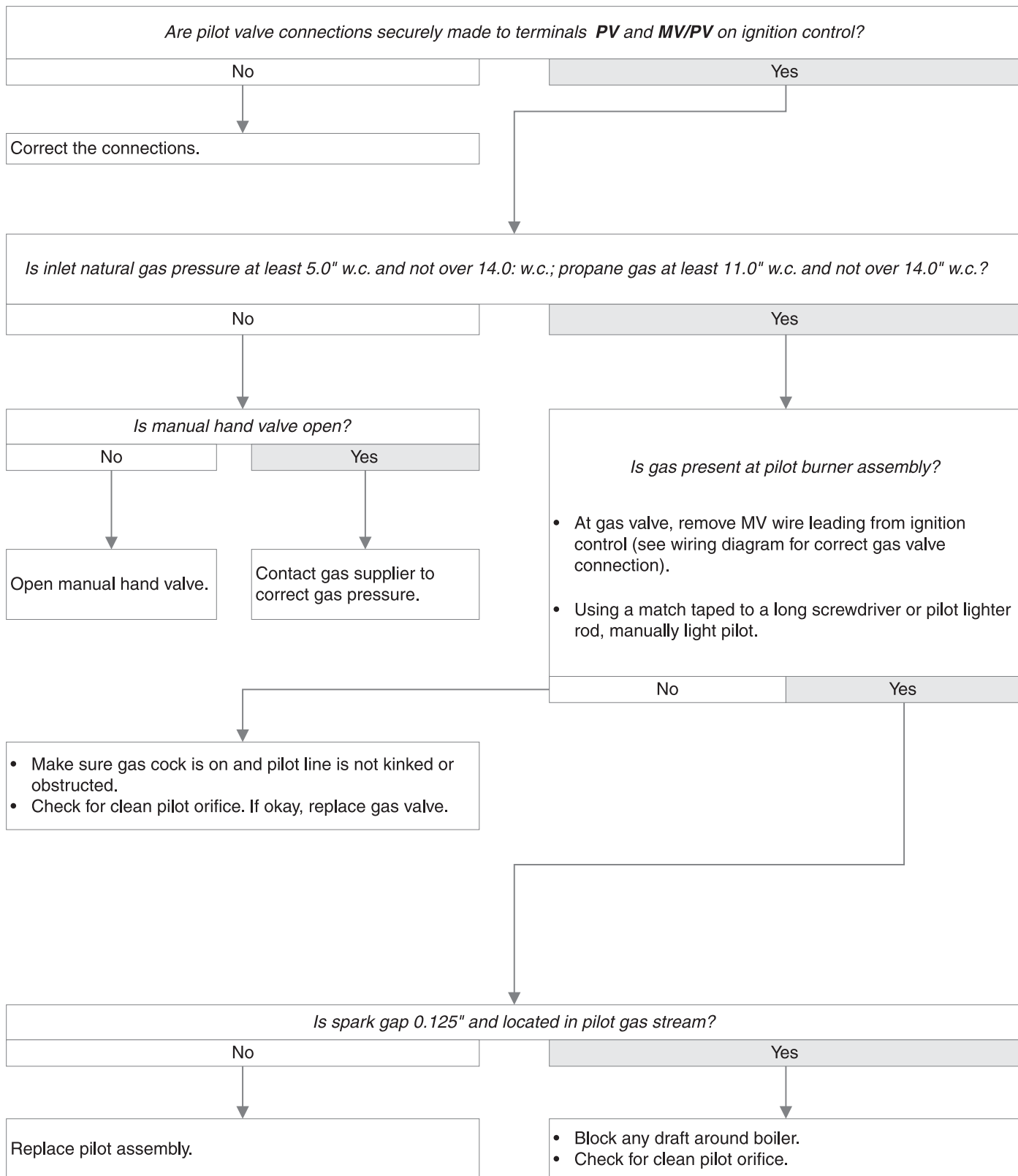
# 12 Troubleshooting continued

## CHART 3 No spark – System does not operate



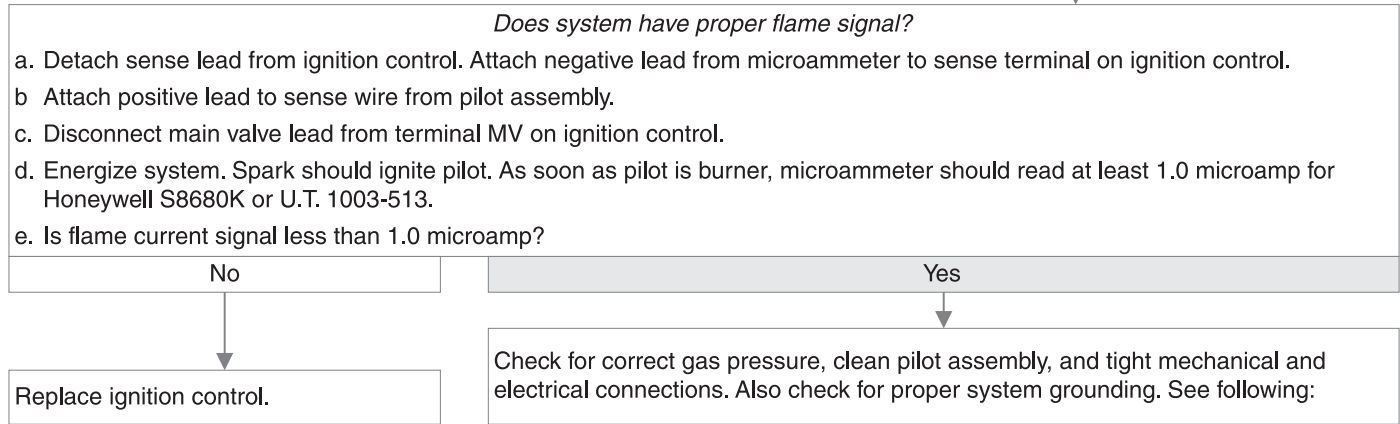
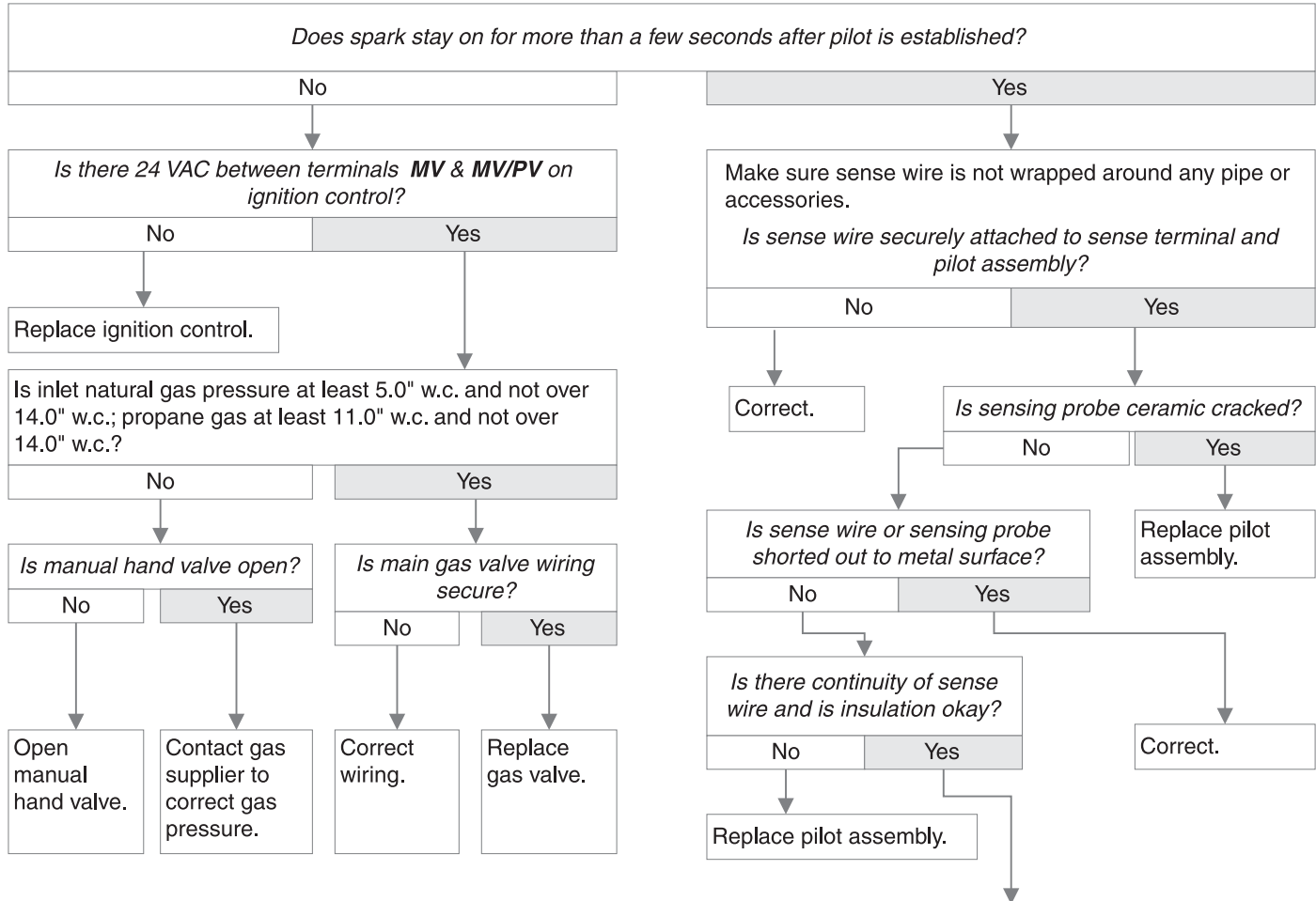
# 12 Troubleshooting continued

## CHART 4 Spark is present – Pilot will not light



# 12 Troubleshooting continued

## CHART 5 Pilot lights – Main valve will not come on



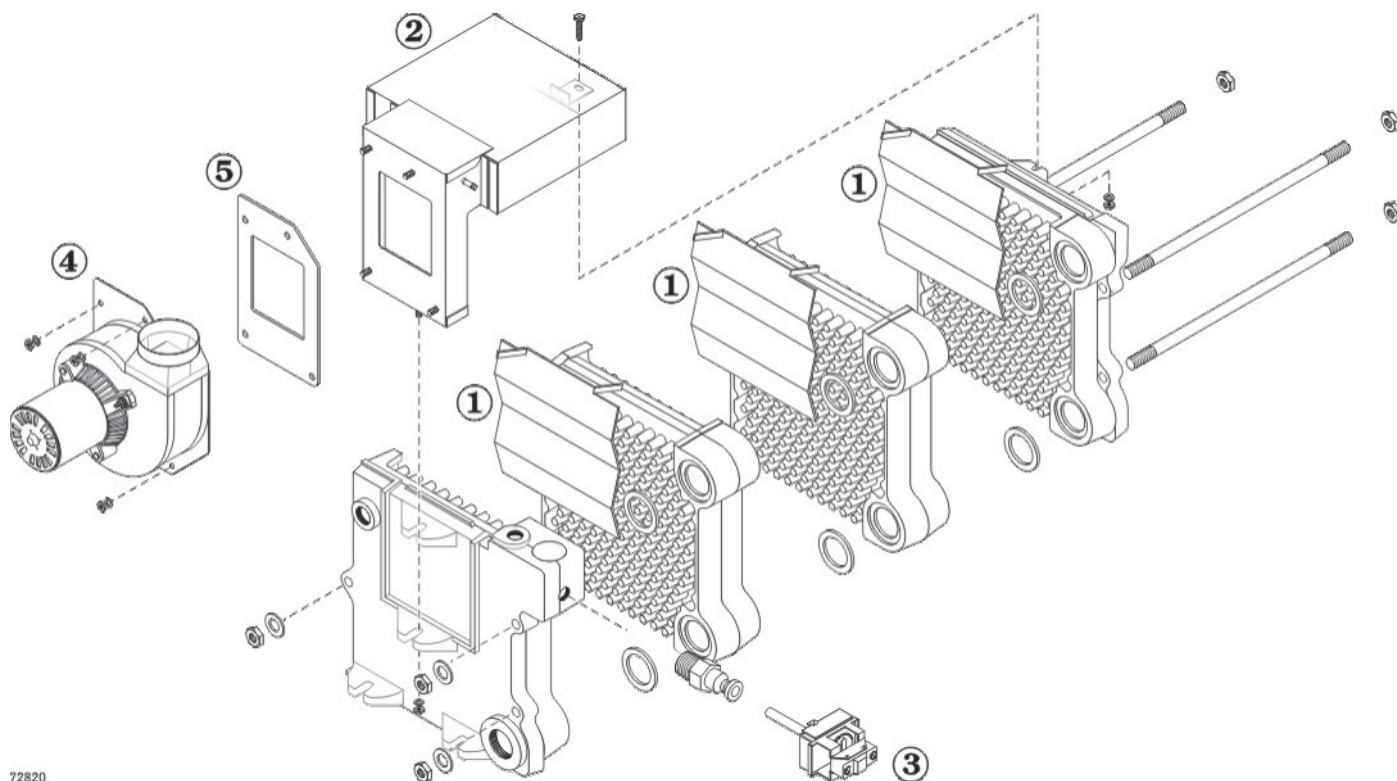
Pilot assembly and ignition control must share common ground with main burner. Nuisance shutdowns are often caused by poor or erratic ground.

- Check for good metal-to-metal contact between pilot burner bracket and main burner, and between main burner and burner rest.
- Check ground lead from **GND (Burner)** terminal on the ignition control to ignition control mounting screw, and from terminal **C** on transformer to the transformer case ground. Make sure connections are clean and tight. If wire is damaged or deteriorated, replace with No. 18 gauge moisture-resistant, thermoplastic wire with 105 °C minimum rating.



## 13 Replacement parts

**Figure 20** Section assembly, flue collector, draft hood and vent damper

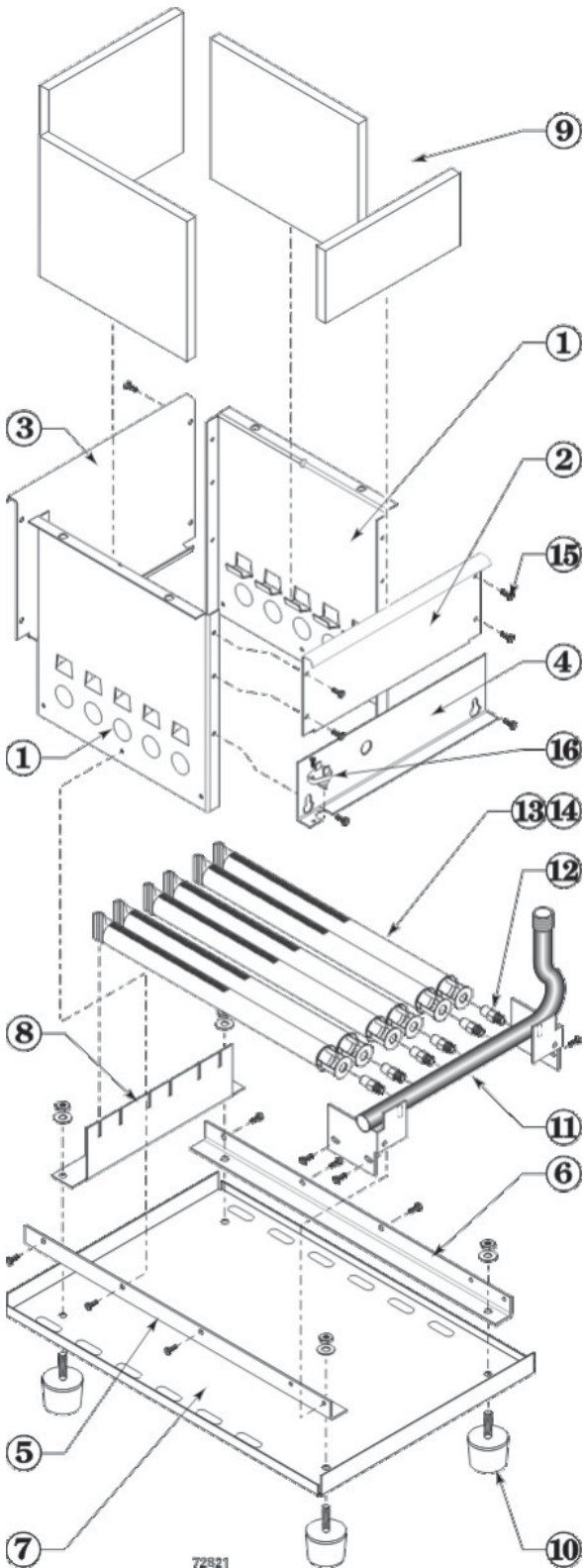


72820

| Item number | Description   |  | Part number  |
|-------------|---|--|--|
| not shown   | Replacement section assembly  | GWI-047 & GWI-063<br>GWI-095<br>GWI-127<br>GWI-158<br>GWI-190  | 321-114-501WT<br>321-114-502WT<br>321-114-503WT<br>321-114-504WT<br>321-114-505WT                  |
| 1           | Radiation plate (1 per joint)   |  | 460-003-700WT  |
| 2           | Collector hood and transition assembly                                | GWI-047<br>GWI-063<br>GWI-095<br>GWI-127<br>GWI-158<br>GWI-190 | 381-354-581WT<br>381-354-582WT<br>381-354-583WT<br>381-354-584WT<br>381-354-585WT<br>381-354-586WT |
| 3           | High limit, 30° differential, with well                               | Honeywell L4080D1036<br>White-Rodgers 11B81-3                  | 510-312-254WT  |
| 4           | Inducer fan assembly kit, includes inducer assembly, gasket and nuts: | GWI-047 to GWI-158<br>GWI-190                                  | 381-354-580WT<br>381-356-499WT   |
| 5           | Gasket, inducer   | GWI-047 to GWI-190   | 590-317-627WT  |

# 13 Replacement parts continued

**Figure 21** Base assembly, manifold, orifices and burners



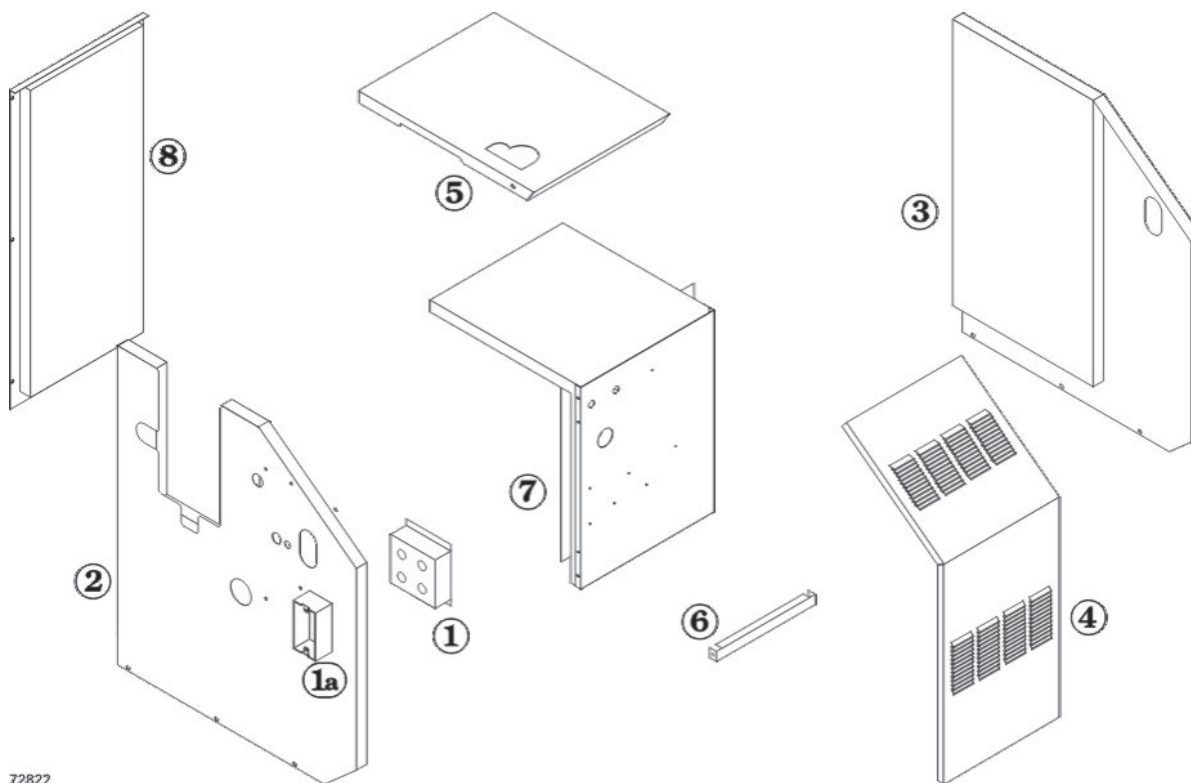
| Item number | Description  |  | Part number  |
|-------------|--|--|--|
|             | Base assembly kit (includes base panels items 1, 2, 3, 4, 5, 6, and 7, plus insulation, air box gaskets, and hardware)         | GWI-047 & GWI-063<br>GWI-095<br>GWI-127<br>GWI-158<br>GWI-190  | 381-354-800WT<br>381-354-801WT<br>381-354-802WT<br>381-354-803WT<br>381-354-804WT                  |
| 1           | Base side panel (in Base assembly)   |  |  |
| 2           | Base front cross-tie assembly (in Base assembly)   |  |  |
| 3           | Base back cross-tie assembly (in Base assembly)  |  |  |
| 4           | Access panel (in Base assembly)  |  |  |
| 5           | Base pan angle, left side (in Base assembly)   |  |  |
| 6           | Base pan angle, right side (in Base assembly)  |  |  |
| 7           | Base pan (in Base assembly)  |  |  |
| 8           | Burner rest (in Base assembly)   |  |  |
| 9           | Base insulation kit (includes insulation for all base parts above plus gasket material needed between block assembly and base) | GWI-047 to GWA-127<br>GWI-158 & GWI-190                        | 381-354-210WT<br>381-354-211WT   |
| 10          | Boiler leg kit   |  | 590-424-252WT  |
| 11          | Manifold   | GWI-047<br>GWI-063<br>GWI-095<br>GWI-127<br>GWI-158<br>GWI-190 | 591-126-615WT<br>591-126-616WT<br>591-126-617WT<br>591-126-618WT<br>591-126-619WT<br>591-126-556WT |
| 12          | Main burner orifice, sea level   | Natural gas<br>Propane gas                                     | 580-528-997WT<br>580-528-998WT   |
| 13          | Burner, stainless steel  |  | 512-200-077WT  |
| 14          | Burner with pilot bracket (not shown)  | Natural gas<br>Propane gas                                     | 512-200-078WT<br>512-200-079WT   |
| 15          | Screw, 10-32 x 3/8 STP type D hx, washer head slot ZP  |  | available at local supply house  |
| 16          | Rollout thermal fuse element   |  | 512-050-230WT  |

**WARNING**

The boiler contains ceramic fiber and fiberglass materials. Use care when handling these materials per instructions on page 40 of this manual. Failure to comply could result in severe personal injury.

# 13 Replacement parts continued

**Figure 22** Jacket assembly



72822

| Item number | Description  | Part number   |
|-------------|--|---|
| 1 & 1a      | Junction boxes, 4 x 4 and 2 x 4<br>(Available at local supply house) |   |
| 2           | Jacket panel, left side, with insulation                             | 431-223-491WT   |
| 3           | Jacket panel, right side   | 431-223-426WT   |
| 4           | Jacket panel, door   | GWI-047 & GWI-063 431-223-450WT<br>GWI-095 431-223-451WT<br>GWI-127 431-223-452WT<br>GWI-158 431-223-453WT<br>GWI-190 431-223-454WT |
| 5           | Jacket top panel   | GWI-047 & GWI-063 431-223-439WT<br>GWI-095 431-223-440WT<br>GWI-127 431-223-441WT<br>GWI-158 431-223-442WT<br>GWI-190 431-223-443WT |

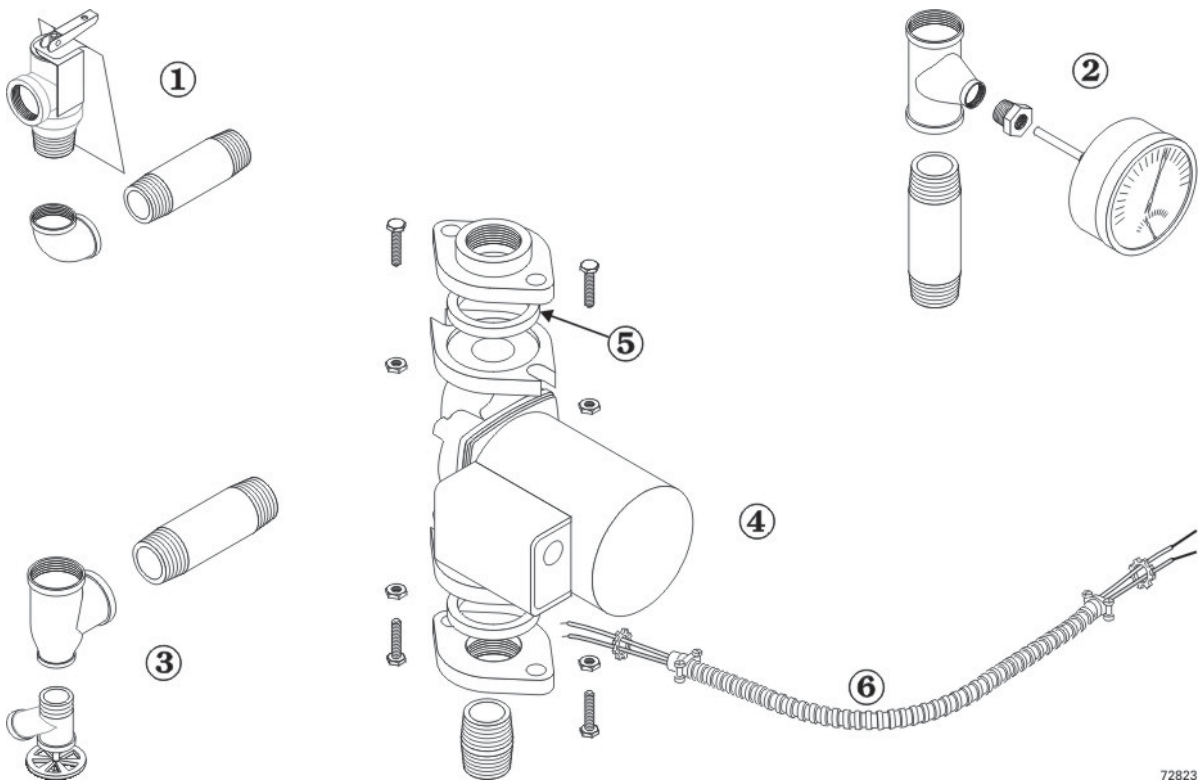
| Item number | Description            | Part number   |
|-------------|------------------------|---|
| 6           | Jacket cross tie       | GWI-047 & GWI-063 431-223-507WT<br>GWI-095 431-223-508WT<br>GWI-127 431-223-509WT<br>GWI-158 431-223-510WT<br>GWI-190 431-223-511WT |
| 7           | Jacket panel, interior | GWI-047 & GWI-063 431-223-427WT<br>GWI-095 431-223-428WT<br>GWI-127 431-223-429WT<br>GWI-158 431-223-430WT<br>GWI-190 431-223-431WT |
| 8           | Jacket panel, rear     | GWI-047 & GWI-063 431-223-444WT<br>GWI-095 431-223-445WT<br>GWI-127 431-223-446WT<br>GWI-158 431-223-447WT<br>GWI-190 431-223-448WT |

**WARNING**

The boiler contains ceramic fiber and fiberglass materials. Use care when handling these materials per instructions on page 40 of this manual. Failure to comply could result in severe personal injury.

# 13 Replacement parts continued

**Figure 23** Trim assembly

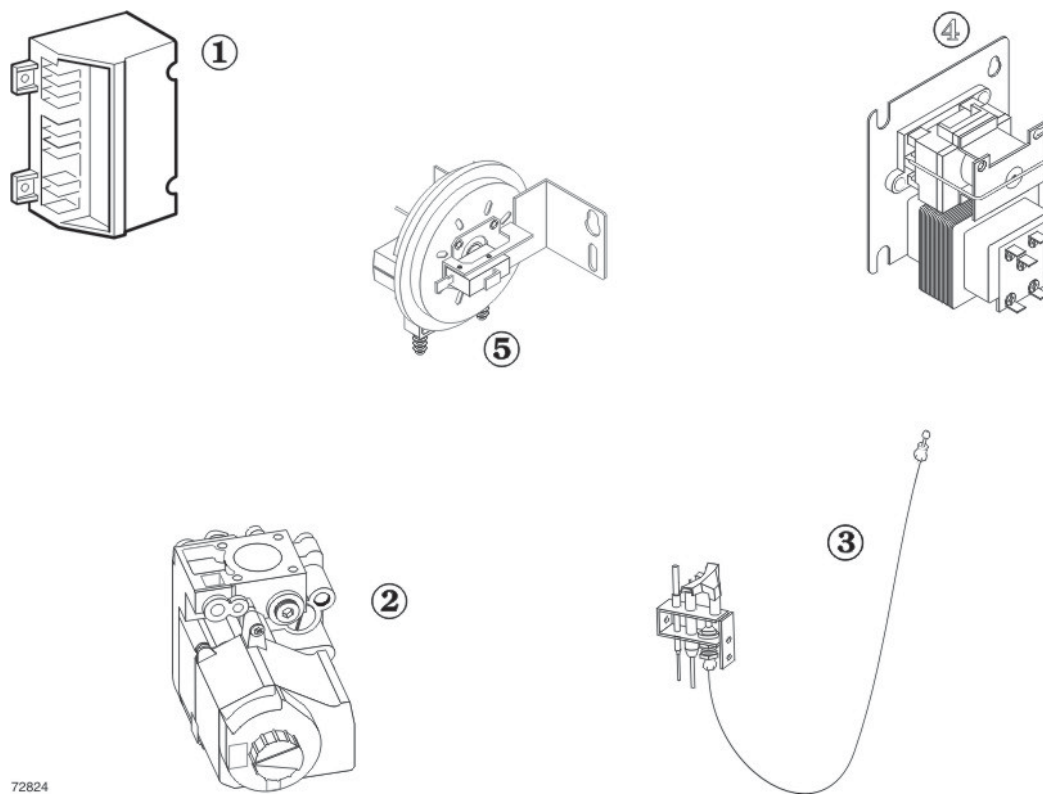


72823

| Item number | Description   | Manufacturer                                      | Manufacturer's part number          | Part number                    |
|-------------|---|---|-------------------------------------|--------------------------------|
| 1           | Pressure relief valve, ASME, 30 PSIG, 3/4" male inlet   | Conbraco Watts                                    | 10-407-10 M330                      | 511-546-920WT                  |
|             | Pressure relief valve, ASME, 30 PSIG, 3/4" female inlet<br><i>(Fittings shown are factory-installed on boiler.)</i>   | Conbraco Watts                                    | 10-408-05 335                       | 511-546-924WT                  |
| 2           | Combination pressure-temperature gauge, with 2 1/2" short shank   | Ametek ENFM                                       | PTA-1088 4104                       | 510-218-099WT                  |
| 3           | Drain valve, 3/4"<br><i>(Fittings shown are included with boiler.)</i>  | Conbraco<br>Hammond Valve<br>Matco-Norca<br>Watts | 31-606-01<br>710<br>205F04<br>BD-2C | 511-210-423WT                  |
| 4           | Circulator <i>(Fittings shown are shipped loose with boiler.)</i>   | Taco  | 007                                 | 511-405-113WT                  |
| 5           | Circulator gasket, universal (2 per boiler)   |   |                                     | 590-317-535WT                  |
| not shown   | Circulator hardware kit, includes:<br>2 flanges, 4 nuts, 4 screws, 2 pipe nipples —<br>1" NPT — GWI-047 through GWI-127<br>1 1/4" NPT — GWI-158 through GWI-190 |   |                                     | 381-354-525WT<br>381-354-526WT |
| 6           | Circulator wiring harness   |   |                                     | 591-319-793WT                  |

# 13 Replacement parts continued

**Figure 24** Gas control assembly



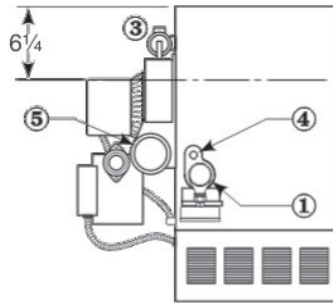
72824

| Item number            | Part description  | Boiler model number | Vendor   | Vendor part number        | Part number   |
|------------------------|---|---------------------|--|---------------------------|---------------|
| <b>1</b>               | Ignition Control  | All                 | United Technologies  | 1003-513 or 1003-613A     | 511-330-099WT |
| <b>2 (Natural gas)</b> | Gas valve, 1/2" x 1/2", Natural gas                           | GW-047 to GW-158    | Honeywell<br>White-Rodgers   | VR8204A-2001<br>36E36-266 | 511-044-381WT |
|                        | Gas valve, 3/4" x 3/4", Natural gas                           | GW-190              | Honeywell<br>White-Rodgers   | VR8304P-4348<br>36C-478   | 511-044-353WT |
| <b>2 (Propane gas)</b> | Gas valve, 1/2" x 1/2", Propane                               | GW-047 to GW-158    | Honeywell<br>White-Rodgers   | VR8204M-2701<br>36E36-291 | 511-044-354WT |
|                        | Gas valve, 3/4" x 3/4", Propane                               | GW-190              | Honeywell<br>White-Rodgers   | VR8304M-4010<br>36C68-479 | 511-044-355WT |
| <b>3 (Natural gas)</b> | Pilot assembly kit with orifice and aluminum pilot gas tubing | All                 |  |                           | 511-330-166WT |
| <b>3 (Propane gas)</b> | Pilot assembly kit with orifice and aluminum pilot gas tubing | All                 |  |                           | 511-330-211WT |
| not shown              | Boiler wiring harness   | All                 |  |                           | 591-319-795WT |
| <b>4</b>               | Transformer/relay assembly<br>Transformer only<br>Relay only  | All                 | Honeywell R825D100 or White-Rodgers 631-9001<br>Honeywell R8285K1004 or White-Rodgers S84A-85<br>Honeywell R8222U1006 or White-Rodgers 91-112006-11000 |                           | 510-312-167WT |
| <b>5</b>               | Pressure switch, 1.19 Inches W. C.                            | GW-047 & GW-063     | Tri-Delta  | PP510193-3120             | 511-624-350WT |
|                        | Pressure switch, 1.08 Inches W. C.                            | GW-095              |  | PP510193-3121             | 511-624-351WT |
|                        | Pressure switch, 0.86 Inches W. C.                            | GW-127              |  | PP510193-3122             | 511-624-352WT |
|                        | Pressure switch, 0.61 Inches W. C.                            | GW-158              |  | PP510193-3123             | 511-624-353WT |
|                        | Pressure switch, 0.76 Inches W. C.                            | GW-190              |  | PP510193-3124             | 511-624-354WT |

# 14 Dimensions

**Figure 25** Dimensional drawing — **ALL DIMENSIONS IN INCHES**

- ① Supply, 1¼" NPT NPT (Note 1)
- ② Return, 1¼" NPT NPT (Note 1)
- ③ Relief valve, ¾" NPT
- ④ ½" NPT to expansion tank/air vent
- ⑤ Vent connection, 3" diameter
- ⑥ Inducer
- ⑦ Gas supply piping
- ⑧ Drain valve
- ⑨ Gas supply entrance (right or left side)
- ⑩ Pressure/temperature gauge

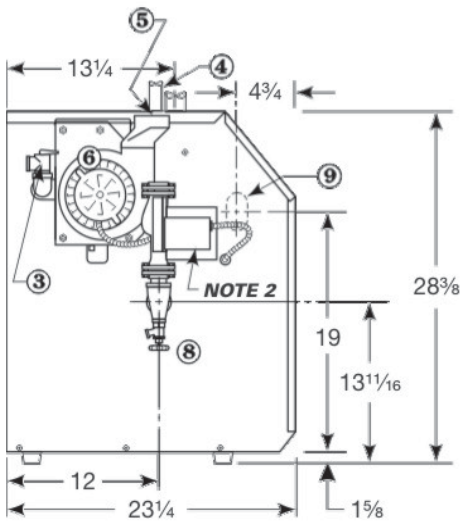


**TOP VIEW**

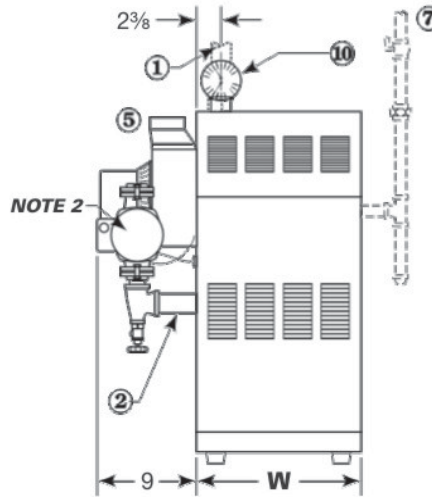
**Note 1:** Boiler supply and return tapings are both 1¼" NPT. See Table 6, page 13, for recommended system supply and return piping sizes.

**Note 2:** Boiler circulator is shipped loose. Circulator may be mounted on either boiler supply or return piping. Circulator flange provided with boiler is same size as recommended pipe size in Table 6, page 13.

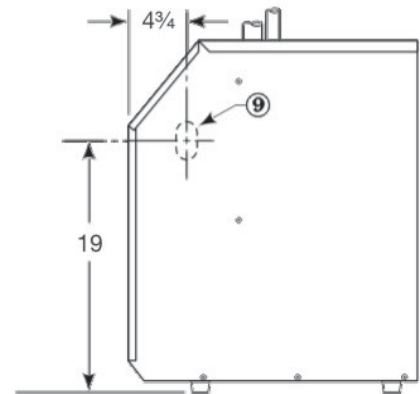
**ALL DIMENSIONS IN INCHES**



**LEFT SIDE**



**FRONT**



**RIGHT SIDE**

72835

| Boiler model number | Supply tapping (inches NPT) | Return tapping (inches NPT) | Gas connection size (Note 3) (inches NPT) | Gas manifold size (Note 3) (inches NPT) | "W" Jacket width (inches) |
|---------------------|-----------------------------|-----------------------------|---|---|---------------------------|
| GWI-047             | 1 ¼                         | ¾                           | ½   | ½                                       | 10                        |
| GWI-063             | 1 ¼                         | 1                           | ½   | ½                                       | 10                        |
| GWI-095             | 1 ¼                         | 1                           | ½   | ½                                       | 13                        |
| GWI-127             | 1 ¼                         | 1                           | ½   | ½                                       | 16                        |
| GWI-158             | 1 ¼                         | 1 ¼                         | ½   | ½                                       | 19                        |
| GWI-190             | 1 ¼                         | 1 ¼                         | ¾   | ¾                                       | 22                        |

Note 3: Gas piping from meter to boiler to be sized per local utility requirements.

# 15 Ratings

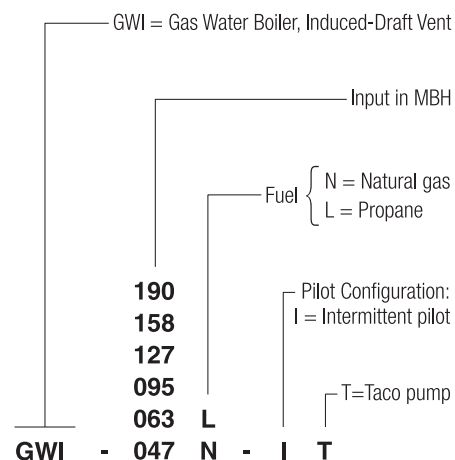


**DOE**

| Boiler model number | 0–2,000 feet altitude |                                      | 2,000–4,500 feet altitude (Canada) |               | Net I=B=R ratings (Btuh) | Boiler water content (gallons) | DOE seasonal efficiency (% A.F.U.E) | Vent size |
|---------------------|-----------------------|--------------------------------------|------------------------------------|---------------|--------------------------|--------------------------------|-------------------------------------|-----------|
|                     | Input (Btuh)          | DOE Heating Capacity (Output) (Btuh) | Input (Btuh)                       | Output (Btuh) |                          |                                |                                     |           |
| (Note 1)            |                       | (Note 2)                             | (Note 5)                           |               | (Note 3)                 |                                |                                     | (Note 4)  |
| <b>GW</b> I-047     | 47,500                | 39,900                               | 42,750                             | 35,910        | 37,000                   | 1.5                            | 83.0                                | 3"        |
| <b>GW</b> I-063     | 63,000                | 52,700                               | 56,700                             | 47,430        | 49,000                   | 1.5                            | 83.3                                | 3"        |
| <b>GW</b> I-095     | 95,000                | 79,800                               | 85,500                             | 71,820        | 73,000                   | 2.1                            | 83.0                                | 3"        |
| <b>GW</b> I-127     | 127,000               | 106,000                              | 114,300                            | 95,400        | 97,000                   | 2.7                            | 82.7                                | 3"        |
| <b>GW</b> I-158     | 158,000               | 131,500                              | 142,200                            | 118,350       | 121,000                  | 3.3                            | 82.4                                | 3"        |
| <b>GW</b> I-190     | 190,000               | 157,700                              | 171,000                            | 141,300       | 144,000                  | 3.8                            | 82.1                                | 3"        |

**Notes**

1. See **information at right** for model number suffixes.
2. Based on standard test procedures prescribed by the United States Department of Energy.
3. Net I=B=R ratings are based on net installed radiation of sufficient quantity for the requirements of the building and nothing need be added for normal piping and pickup. Ratings are based on a piping and pickup allowance of 1.15. An additional allowance should be made for unusual piping and pickup loads.
4. Vent size shown is for Category III venting (pressurized vent). See page 8 for required vent sizing when chimney draft (Category I) venting.
5. Contact your local dealer regarding information and parts for high altitude applications.



**NOTICE** Install GWI boilers for residential radiant panel systems, converted gravity heating systems or other low water temperature applications per instructions in this manual to avoid damage due to condensation. GWI boilers are CSA design certified for installation on combustible flooring. GWI boilers are ASME rated for 50 psig working pressure.

# Handling ceramic fiber and fiberglass materials

## REMOVAL OF COMBUSTION CHAMBER LINING OR BASE PANELS

**WARNING**

The combustion chamber lining or base insulation panels in this product contain ceramic fiber materials. Ceramic fibers can be converted to cristobalite in very high temperature applications. The International Agency for Research on Cancer (IARC) has concluded, "Crystalline silica inhaled in the form of quartz or cristobalite from occupational sources is carcinogenic to humans (Group 1).":

- Avoid breathing dust and contact with skin and eyes.
  - Use NIOSH certified dust respirator (N95). This type of respirator is based on the OSHA requirements for cristobalite at the time this document was written. Other types of respirators may be needed depending on the job site conditions. Current NIOSH recommendations can be found on the NIOSH web site at <http://www.cdc.gov/niosh/homepage.html>. NIOSH approved respirators, manufacturers, and phone numbers are also listed on this web site.
  - Wear long-sleeved, loose fitting clothing, gloves, and eye protection.
- Apply enough water to the combustion chamber lining or base insulation to prevent airborne dust.
- Remove combustion chamber lining or base insulation from the boiler and place it in a plastic bag for disposal.
- Wash potentially contaminated clothes separately from other clothing. Rinse clothes washer thoroughly.

**NIOSH stated First Aid.**

- Eye: Irrigate immediately
- Breathing: Fresh air.

## REMOVAL OF FIBERGLASS WOOL — OR —

## INSTALLATION OF FIBERGLASS WOOL, COMBUSTION CHAMBER LINING OR BASE PANELS:

**WARNING**

This product contains fiberglass jacket insulation and ceramic fiber materials in combustion chamber lining or base panels in gas fired products. Airborne fibers from these materials have been listed by the State of California as a possible cause of cancer through inhalation.

- Avoid breathing dust and contact with skin and eyes.
  - Use NIOSH certified dust respirator (N95). This type of respirator is based on the OSHA requirements for fiberglass wool at the time this document was written. Other types of respirators may be needed depending on the job site conditions. Current NIOSH recommendations can be found on the NIOSH web site at <http://www.cdc.gov/niosh/homepage.html>. NIOSH approved respirators, manufacturers, and phone numbers are also listed on this web site.
  - Wear long-sleeved, loose fitting clothing, gloves, and eye protection.
- Operations such as sawing, blowing, tear out, and spraying may generate airborne fiber concentration requiring additional protection.
- Wash potentially contaminated clothes separately from other clothing. Rinse clothes washer thoroughly.

**NIOSH stated First Aid.**

- Eye: Irrigate immediately
- Breathing: Fresh air.