



# Solo Plus

Wood-fired  
Gasification  
Add-on Boiler

- Easy to Operate
- High Efficiency
- Carbon Neutral
- DS/EN ISO 9001 Certified



# Solo Plus

## Wood-fired Gasification Add-on Boiler



### Independence and Self-Reliance

Solo Plus boilers provide a convenient, safe, and environmentally responsible way to heat your home and hot water with wood. Solo Plus owners are ensured of unusually high heating efficiency, low heating costs, and use of an abundant, locally available, renewable fuel. The Solo Plus wood gasification combustion technology is the most efficient way to burn cordwood. As a result, the Solo Plus boiler uses substantially less wood than conventional wood boilers and outdoor water stoves. Additionally, this high-efficiency burn technology produces little or no creosote, virtually eliminating the risk of chimney fires and greatly reducing greenhouse gas emissions.

### Sizing Your Boiler

As with any heating system, choosing an appropriately sized heat source is

necessary to optimize efficiency, ease of operation and home comfort. Be wary of using simple techniques based only on square footage. The heat load of a home can vary widely depending on age and type of construction, type of heating system and location of the home. If you have questions about which boiler is most appropriate for your needs, please contact your local BioHeatUSA dealer or contact us directly at our toll free number and we would be happy to discuss your application with you.

### Reliability

The internal boiler is made of fully welded 7mm thick plate steel. BioHeat USA boilers are constructed to European boiler design standard EN 303-5 and are designed for pressurized systems. Solo Plus boilers are UL and ULC approved.

### Efficiency

The Solo Plus boiler uses down draft gasification technology to achieve very high efficiency. The key to this process is the high temperature (1800° or more) reached in a second refractory-lined combustion chamber. This secondary combustion consumes the creosote and smoke that normally goes up the chimney, thereby wringing every bit of energy out of the wood fuel and resulting in a very clean burn.

### Solo Plus Applications

- add on to your existing fossil-fuel-fired or electric heating system
- hot water baseboard
- radiant floors
- hot air

The three-inch vertical heat exchange tubes are sized for maximum extraction of the energy in the high-temperature exhaust stream. Despite the very high secondary burn temperatures, stack temperatures remain relatively low. Periodic brushing of the heat exchange tubes will help maintain boiler efficiency, and is easily accomplished via the hatch on the top of the boiler.



*A heat storage unit is an excellent addition to any home heating solution.*

### Optimization and Heat Storage

Firewood burns most efficiently and cleanly when it is burned hot and fast. Down draft gasification facilitates just this kind of burn. Your home, however, does not use heat in this same way; it calls for heat only as needed. In order to match both of these demands, we recommend combining a wood boiler with a water storage tank of 500-1000 gallons. Instead of smoking and smoldering in idle mode when your home is up to temperature, a storage tank will allow the Solo Plus to continue to burn at maximum efficiency. The excess heat generated will simply be stored in the water tank for later use. A certain amount of idling is acceptable, and if you are only intending to burn wood during the coldest part of the year, no storage tank is necessary. However, once the warm days of early spring arrive, it will be time to shut down your wood boiler for the summer. By incorporating thermal storage you maximize the efficiency of your wood boiler and are able to use it throughout the spring and fall—and even right through summer—to produce your domestic hot water, if you choose. Thermal storage can easily be added to a system at a later date.

### About BioHeatUSA

*BioHeatUSA™, formerly Tarm USA, is a third-generation, family-owned business that has pioneered the sales and service of European residential central heating equipment in North America for over 30 years. BioHeatUSA's primary objective is to offer innovative home heating solutions, along with a significant commitment to consumer education and environmental awareness. Exclusive partnerships with ISO 9001 certified manufacturers allows BioHeatUSA to offer products with operational reliability, unique firing efficiency, and to promote the clean burning of carbon-cycle biomass that is critical to the lowering of net greenhouse gas emissions.*

### About Scandtec

*Scandtec, located in Skjern, Denmark, is a producer of central heating biomass boilers. Hans Sorenson, the former Managing Director of Baxi, (and grandson of the founder of HS Tarm), now owns and manages the company which employs an experienced team of R&D and production/distribution professionals.*

## Features

- 75-80% overall efficiency
- clean burn with virtually no smoke or creosote
- large, easily accessible firebox
- easy to clean with very little ash

**Combustion** is regulated by a thermostatically controlled draft blower that forces combustion air into the boiler's ceramic combustion tunnel. Here, exceptionally efficient combustion takes place at high temperatures allowing the Solo Plus to use very little fuel in comparison to "conventional" boilers.

## How It Works

Solo Plus is a patented, wood-fired gasification boiler available in three sizes with outputs from 100,000 to 198,000 BTU/hr. The wood gasification combustion process within the Solo Plus begins when the small, quiet draft fan turns on in response to your home's thermostat.

The draft fan forces fresh air into the top of the firebox and down through the wood and live charcoal bed. This hot air and smoke mixture is forced through a slot in the top of the ceramic combustion chamber. Super-heated secondary air is injected into these gases. The correct combination of wood, gas, smoke and

high-temperature oxygen results in an 1800° flame in the ceramic combustion tunnel. Gases stay in this hot, turbulent environment long enough to achieve extremely high combustion efficiency. The resultant high-temperature gases pass into the vertical heat exchange tubes, giving off heat to the boiler water for house heating and hot water demands.



Image used for informational purposes only.  
Actual appearance may vary.

## Standard Equipment

- jacket with insulation
- steel doors with gasketing
- draft fan
- relief valve
- boiler control
- cleaning implements
- manual

## Optional Equipment

- heat storage system
- domestic hot water coil
- Termovar boiler protection valve
- contact BioHeat USA for a full list of accessories

## Warranty

Each Solo Plus boiler is covered by a 20-year limited warranty. A copy is available for your inspection, and is provided with each boiler.

## Disclaimer

BioHeat USA is not responsible for factory alterations to measurements. For final specifications, please see the Scandtec Solo Plus Owner's Manual.

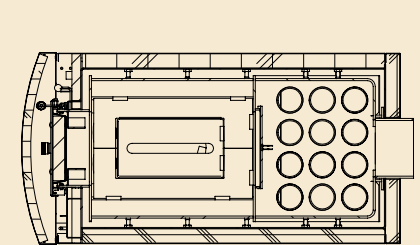
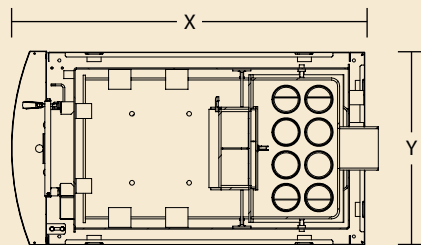
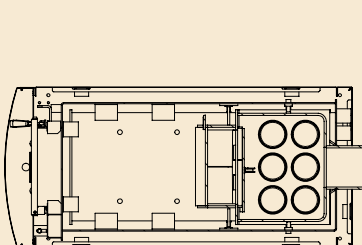
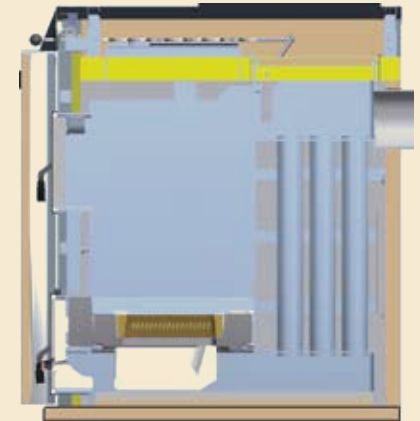
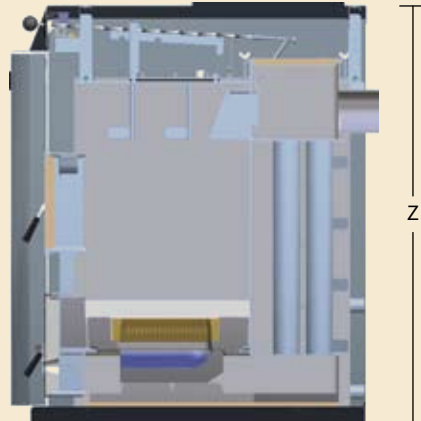
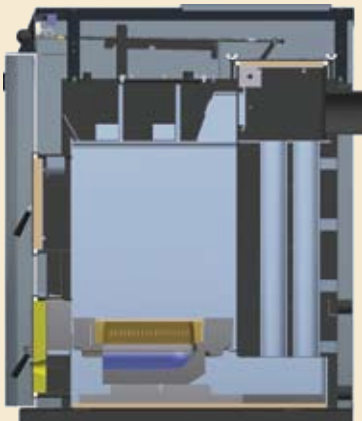

**Solo Plus 30**

**Solo Plus 40**

**Solo Plus 60**

Technical Data		30	40	60
Maximum heat/output	BTU/hr	100,000	140,000	198,000
Firebox depth	inches	21	21	21
Load door	in. X in.	10 X 12	10 X 12	10 X 12
Firebox volume	cubic feet	4.01	5.35	6.01
Maximum wood length	inches	20	20	20
Test pressure boiler	PSI	65	65	65

Dimensions are subject to technical alterations.

Technical Data		30	40	60
Unit length	X inches	46½	46½	50½
Unit width	Y inches	21	25	25
Unit height	Z inches	55½	55½	55½
Unit weight	pounds	1,080	1,180	1,230
Flue collar size	inches	6	6	8
Height of flue collar	inches	41¾	41¾	41¾

Storage tank ideal volume is 100 gallons/14,000 BTUs