

SERIES 19A

# Smith

**Smith**  
CAST IRON BOILERS



series 19A

PRESSURIZED WET BASE  
BOILER/BURNER UNIT

**THE HEATING Pros**



# series 19A

Smith 19A Series cast iron, pressurized, wet-base boiler/burner units are ideal for light commercial water or steam heating systems utilizing No. 2 fuel oil, natural gas, or combination gas/oil. Ten different sizes are available, ranging from three-section, 297 MBH I=B=R gross output units to twelve-section, 1713 MBH I=B=R gross output units. Series 19A boilers are available in three ways — knocked down, assembled sections, or completely packaged units. All sections are tested and approved for 80 psi working pressure as standard equipment.



## STANDARD EQUIPMENT

### All Boilers

- Cast iron wet-base sections tested for 80psi.
- Insulated metal jacket
- Cast iron smokehood with integral damper
- Burner mounting plate with insulation block
- Front and rear flame observation ports
- Steel angle floor rails
- Hi-Temp hydronic port seals
- Flue brush
- Target Wall (3-6 sections)

### Water Boiler/Burner Units

- ASME relief valve, 40 psi
- Theraltimeter
- Manual reset, Hi-Limit control
- Lo-Limit operating control

### Steam Boiler/Burner Units

- ASME side outlet safety valve, 15 psi
- Steam gauge (0-30 psig)
- Gauge glass with gauge cocks and guards
- Manual reset, Hi-Limit control
- Lo-Limit operating control

*All sizes exceed the Ashrae 90.1 efficiency requirements*

## Designed and Constructed for Easy Service and Long Life.

19A Series boiler/burner units are designed and constructed for easy service. A front observation port allows the serviceman to visually check the flame and combustion area. Easy-to-remove, side-mounted cover plates make boiler clean-out quick and easy. Side-mounted tankless 9 GPM coils allow for easy visual inspection and/or replacement. Heavy-duty, hydrocarbon-resistant Viton port seal gaskets are exceptionally easy to install. The integral, cast-iron, fail-safe breeching damper may be easily adjusted and securely locked in position. Individual section draw rods simplify assembly while reducing stress.



## Reliable, Fuel-Efficient Heat

Smith 19A Series boiler/burner units are designed and constructed for high efficiency and top performance. High-quality cast iron sections, cast-in heat extraction pins, completely insulated metal jacket, ceramic fiber rope section seals, obround-shaped upper ports, and carefully selected, high-efficiency burner add up to a boiler/burner unit that will provide reliable, fuel-efficient heat for years to come.

Compare Smith 19A Series units with other brands with similar capacities — you'll discover that Smith is your smartest choice.

# PRESSURIZED WET-BASE BOILER BURNER UNITS

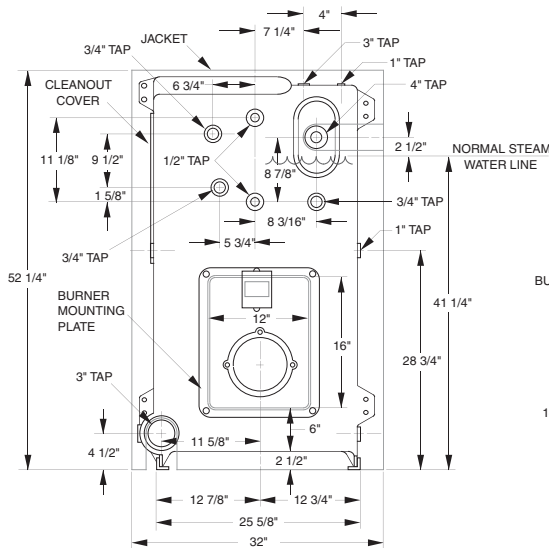

FRONT VIEW

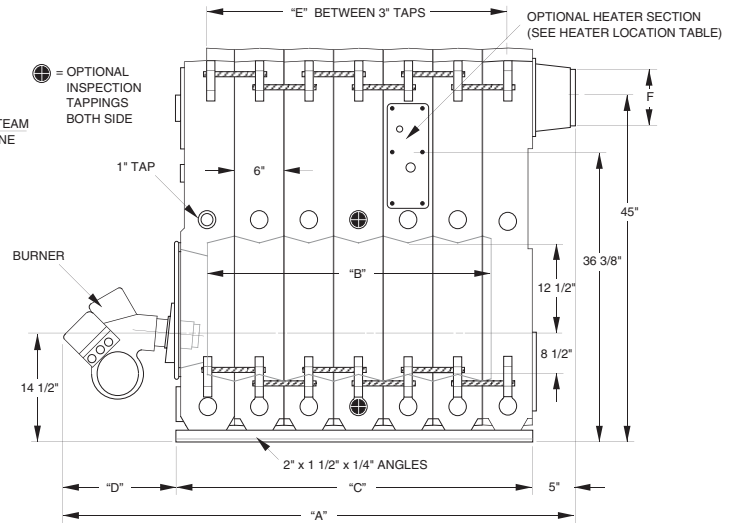

SIDE VIEW

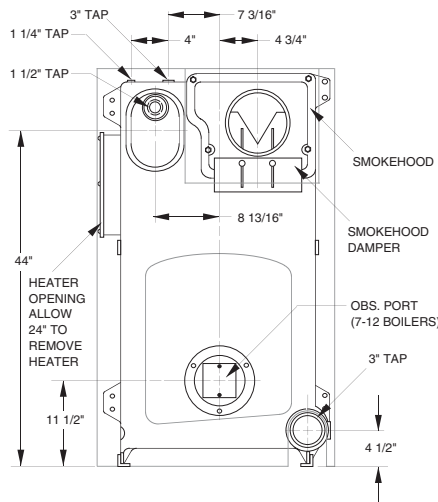

REAR VIEW

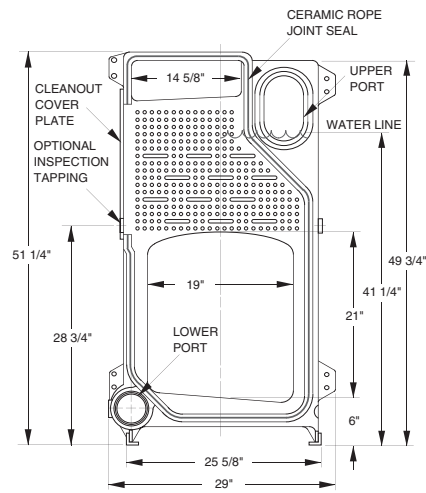

INTERMEDIATE SECTION

## Dimensions (inches)

Boiler Number	Overall Length "A"						"B"	"C"	Burner Length "D"						"E" Distance Between Supply Tappings	"F" Flue Pipe Diameter
	Carlin	PF/J	PF/C	Beckett	GP/V	GP/R			Carlin	PF/J	PF/C	Beckett	GP/V	GP/R		
†19A-*-3	39	44	-	31	-	-	9	18	16	21	-	13	-	-	12	7
†19A-*-4	45	50	59	37	-	-	15	24	16	21	30	13	-	-	18	7
†19A-*-5	51	56	65	43	53	-	21	30	16	21	30	13	18	-	24	8
†19A-*-6	61	62	71	49	59	67	27	36	20	21	30	13	18	26	30	8
†19A-*-7	67	68	82	64	65	75 1/2	33	42	20	21	35	22	18	28 1/2	36	9
†19A-*-8	73	74	88	71	71	81 1/2	39	48	20	21	35	23	18	28 1/2	42	10
†19A-*-9	79	80	94	77	77	87 1/2	45	54	20	21	35	23	18	28 1/2	48	10
†19A-*-10	87	86	100	83	83	93 1/2	51	60	22	21	35	23	18	28 1/2	54	10
†19A-*-11	93	-	106	89	-	99 1/2	57	66	22	-	35	23	-	28 1/2	60	10+
†19A-*-12	99	-	112	99	-	105 1/2	63	72	22	-	35	27	-	28 1/2	66	10+

The manufacturer should be consulted before selecting a boiler for installations having unusual piping and pickup requirements, such as intermittent system operation, extensive piping, etc.

For forced hot water heating systems where the boiler and all the piping are within the area to be heated, the boiler may be selected on the basis of its Gross Output.

+ 11 and 12 section requires 12" diameter vent pipe. Transition collar provided by Smith.

**NOTE: Dimensions are approximate. Should not be used to "rough-in" equipment.**

## Assembled Block or Packaged Boiler without Burner

NO. OF SECTIONS	CHANNEL LENGTH DIM. "A"	ANGLE LENGTH DIM. "B"
3	39	18
4	45	24
5	51	30
6	57	36
7	63	42
8	69	48
9	75	54
10	81	60
11	87	66
12	93	72

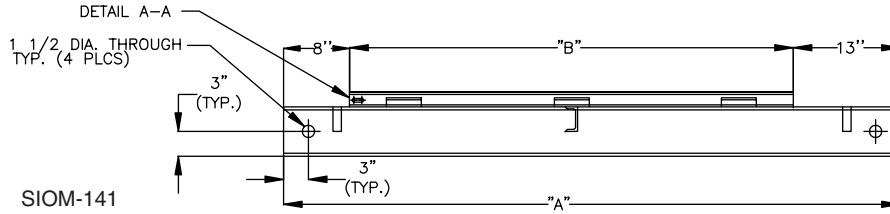

## Packaged Boiler with Burner

NO. OF SECTIONS	CHANNEL LENGTH DIM. "A"			ANGLE LENGTH DIM. "B"
	CARLIN/BECKETT	POWERFLAME J-SERIES	POWERFLAME C-SERIES	
3	49	59	18	
4	55	65	24	
5	61	71	30	
6	67	77	36	
7	78	83	42	
8	84	89	48	
9	90	95	54	
10	99	101	60	
11	105	107	66	
12	111	113	72	

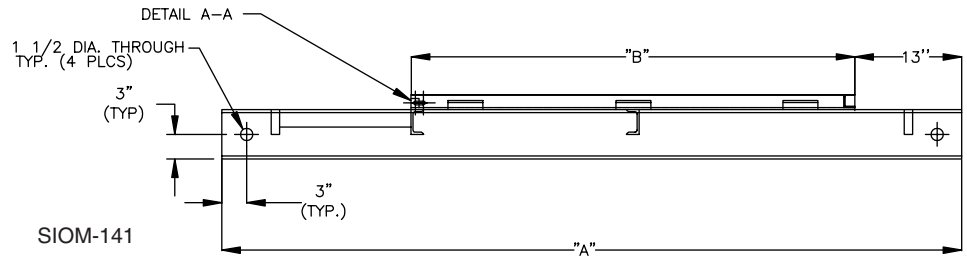

## I B R Ratings, Burner Capacities

Designed and tested to the A.S.M.E. boiler and pressure vessel code, section IV for maximum allowable working pressure, steam 15 psig, water 80 psig.

Boiler Number	Boiler Horsepower	Heating Surface (Sq. Ft.)	Furnace Volume (Cu. Ft.)	I=B=R Gross Output (MBH)	Net I=B=R Rating (1)			I=B=R Burner Capacity		Draft Loss (in W.C.)	Overfire(4) Pressure (in W.C.)	Water Content (Gals.)		Water Working Weight (Lbs.)	
					Steam		Water	Oil(GPH)(2)	Gas(MBH)(3)			Steam	Water	Steam	Water
					(Sq. Ft.)	MBH	MBH								
†19A-*-3	9	23.9	2.12	297	929	223	258	2.60	375	0.18	0.28	33.2	38.6	1673.6	1716.8
†19A-*-4	12	35.8	3.50	413	1292	310	359	3.60	520	0.18	0.28	41.1	49.2	2057.8	2122.6
†19A-*-5	17	47.7	4.88	575	1796	431	500	5.00	725	0.20	0.30	49.0	59.8	2442.0	2528.4
†19A-*-6	22	59.7	6.27	738	2308	554	642	6.50	931	0.23	0.33	56.8	70.3	2825.4	2933.4
†19A-*-7	27	71.6	7.65	901	2817	676	783	7.90	1137	0.26	0.36	64.7	80.9	3209.6	3339.2
†19A-*-8	32	83.5	9.04	1063	3321	797	924	9.30	1342	0.29	0.39	72.6	91.5	3593.8	3745.0
†19A-*-9	37	95.4	10.42	1226	3833	920	1066	10.80	1548	0.32	0.42	80.5	102.0	3978.0	4150.0
†19A-*-10	42	107.4	11.81	1388	4383	1052	1207	12.20	1754	0.35	0.45	88.3	112.6	4361.4	4555.8
†19A-*-11	46	119.3	13.20	1551	4946	1187	1349	13.60	1989	0.38	0.48	96.2	123.1	4745.6	4960.8
†19A-*-12	51	131.2	14.58	1713	5508	1322	1490	15.00	2165	0.41	0.51	104.0	133.7	5129.0	5366.6

† No insert for oil. Insert prefix "G" for gas or "GO" for combination gas/oil.

\* Insert "S" for steam, "W" for water. Example: GO19A-S-10 is a 10-section 19A Series Boiler for steam using combination gas/oil burner.

(1) The net I=B=R Steam Ratings shown are based on a piping and pickup allowance of 1.333. The I=B=R Water Ratings shown are based on an allowance of 1.15.

(2) Based on light oil having a heat content of 140,000 BTU per gallon.

(3) Gas having a heat content of 1,000 BTU/cu. ft. at 0.6 specific gravity.

(4) Includes 0.10" W.C. pressure on upstream side of exit damper.

## Side-Mounted Tankless Heater Capacities

No. of Sections	I=B=R Gross Output MBH	Cont. Draw (GPM)		
		One Heater	Two Heaters	Three Heaters
3	297	8.5	N/A	N/A
4	413	8.5	N/A	N/A
5	575	9.0	10.6	N/A
6	738	9.0	12.9	N/A
7	901	9.0	15.3	N/A
8	1063	9.0	17.6	N/A
9	1226	9.0	18.0	19.9
10	1388	9.0	18.0	22.2
11	1551	9.0	18.0	24.6
12	1713	9.0	18.0	26.9

Heater ratings based on 100° F. temperature rise, 200° F. boiler water, 9 GPM at 9.5 psi Δ P. For 180° boiler water ratings, consult factory.

## Heater Section Location

Boiler Number	Max. No. of heaters	Location by boiler section (Heaters install from right side)
19A-3	1	F - <b>H</b> - B
19A-4	1	F - P - <b>H</b> - B
19A-5	2	F - <b>H</b> - P - <b>H</b> - B
19A-6	2	F - P - <b>H</b> - P - <b>H</b> - B
19A-7	3	F - <b>H</b> - P - <b>H</b> - P - <b>H</b> - B
19A-8	3	F - P - <b>H</b> - P - <b>H</b> - P - <b>H</b> - B
19A-9	3	F - P - <b>H</b> - P - <b>H</b> - P - <b>H</b> - P - B
19A-10	3	F - P - P - <b>H</b> - P - <b>H</b> - P - <b>H</b> - P - B
19A-11	3	F - P - P - P - <b>H</b> - P - <b>H</b> - P - <b>H</b> - P - B
19A-12	3	F - P - P - P - P - <b>H</b> - P - <b>H</b> - P - <b>H</b> - P - B

F = Front, P = Intermediate Plain, **H** = Intermediate Heater, B = Back



## Burners:

### Carlin Light Oil Burner

- High performance, forced draft, UL listed, flame retention oil burner:
  - On-off firing, (4 thru 5 sections), with cadmium cell primary control, oil valve, delay timer. Lo-hi firing (6 thru 12 sections)
  - Single stage fuel unit (3 thru 5 sections)
  - Two stage fuel unit (6 thru 12 sections)

### Beckett Light Oil Burner

- High performance, forced draft, UL listed, flame retention oil burner:
  - On-off firing, (3 thru 5 sections) with cadmium cell primary control, oil valve. Lo-hi off firing (6 thru 12 sections)
  - Single stage fuel unit (3 and 4 sections)
  - Two stage fuel unit (5 thru 12 sections)

### Gordon Piatt Light Oil Burner

- High performance, forced draft, UL listed, flame retention oil burner:
  - On-off firing (6 thru 12 sections), with cadmium cell primary control, oil valve
  - Two stage fuel unit

### Power Flame Gas Burner

- High performance, forced draft, UL listed, power gas burner for natural gas firing:
  - On-off firing, (3 thru 12 sections), fixed air shutter combustion control, 115 volt diaphragm gas shut-off valve, 115 volt solenoid auxiliary gas valve, spark ignited intermittent gas pilot (gas train not assembled), pilot gas train with solenoid valve, pressure regulator and manual shut-off cock, pilot tubing and fittings

### Gordon Piatt Gas/Oil Burner

- Both fuels, spark ignited gas pilot, intermittent UV flame detection, prepurge.
  - On-off firing, (6 thru 12 sections), fixed air louver control, two stage fuel pump, oil valve, slow opening diaphragm gas valve for gas, auxiliary solenoid gas valve. Gas train not assembled

### Power Flame Gas/Oil Burner

- Both fuels — Spark ignited gas pilot, intermittent UV flame detection, prepurge.
  - On-off firing (4 thru 12 sections), with fixed air shutter, two stage fuel pump for oil, oil valve, slow opening diaphragm gas valve for gas, auxiliary solenoid gas valve. Gas train not assembled
  - Pilot gas train with solenoid valve, pressure regulator and manual shut-off cock, pilot tubing and fittings

### Gordon Piatt Gas Burner

- High performance, forced draft, UL listed, power gas burner for natural gas firing.
  - On-off firing, (5 thru 12 sections), fixed air inlet louver control, 115 volt gas diaphragm shut-off valve, 115 volt solenoid auxiliary gas valve, spark ignited intermittent gas pilot. Gas train not assembled
  - Pilot gas train with solenoid valve, pressure regulator and manual shut-off cock, pilot tubing and fittings

# series 19A

## OPTIONAL EQUIPMENT

### All Boilers

- Tankless water heaters
- Heater cover plates
- Sections assembled
- Packaged
- Burner start-up and one-year service
- Low water cutoffs
- Feeder and pump controllers
- Inspection taps and brass plugs (up to four per section)
- Water boilers—80 psi pressure relief valve

#### Beckett & Carlin Oil Burners

- Electronic controls
- Two stage fuel unit (4 thru 6 sections)
- N.Y.C.— D.E.P. (formerly B.A.R.) approval
- Burner mounted, factory wired control panel
- Lo-hi-lo firing (7 thru 12 sections)

#### Power Flame Gas and Oil Burners

- Two stage firing with fuel-air control
- Lo-hi-lo firing
- Modulating firing
- I.R.I., FM, MASS approval
- Other motor current characteristics
- Increased gas train sizes for low pressure drops
- Flame safeguard options

#### Gordon Piatt Gas and Oil Burners

- Two stage firing with fuel-air control
- Lo-hi-lo firing
- Modulating firing
- I.R.I., FM, MASS approval
- Other motor current characteristics
- Flame safeguard options
- Increased gas train sizes for low pressure drops

### Burner Models

No. of Boiler Sections	Carlin Oil	HP	Beckett Oil	HP	Power Flame						Gordon Piatt					
					Oil	HP	Gas	HP	Gas/Oil	HP	Oil	HP	Gas	HP	Gas/Oil	HP
3	201CRD	—	CF500	1/3	—	—	JR15A	1/4	—	—	—	—	—	—	—	—
4	301CRD	1/4	CF500	1/3	CR1-0	1/3	JR15A	1/4	CR1-GO	1/3	—	—	—	—	—	—
5	301CRD	1/4	CF800	1/3	CR1-0	1/3	JR30A	1/4	CR1-GO	1/3	—	—	—	—	—	—
6	702CRD	1/2	CF1400	1/2	CR1-0	1/2	JR30A	1/3	CR1-GO	1/3	R6.3	1/2	R6.3	1/2	R6.3	1/2
7	702CRD	1/2	CF1400	1/2	CR2-0	3/4	JR30A	1/3	CR2-GO	3/4	R8.1	3/4	R8.1	3/4	R8.1	3/4
8	702CRD	1/2	N/A	N/A	CR2-0	3/4	JR50A	1/3	CR2-GO	3/4	R8.1	3/4	R8.1	3/4	R8.1	3/4
9	702CRD	1/2	CF2300	3/4	CR2-0	3/4	JR50A	1/3	CR2-GO	3/4	R8.1	3/4	R8.1	3/4	R8.1	3/4
10	801CRD	3/4	CF2300	3/4	CR2-0	3/4	JR50A	1/3	CR2-GO	3/4	R8.1	3/4	R8.1	3/4	R8.1	3/4
11	801CRD	3/4	CF2500	2	CR2-0	1	CR2G	1/2	CR2-GO	3/4	R8.1	3/4	R8.1	3/4	R8.1	3/4
12	801CRD	3/4	CF2500	2	CR2-0	1 1/2	CR2G	1/2	CR2-GO	3/4	R8.3	1 1/2	R8.3	1 1/2	R8.3	1 1/2



MEA #416-99-M

In the interest of product development, we reserve the right to make changes without notice.

**Smith**  
CAST IRON BOILERS

Westcast, Inc., 260 North Elm Street, Westfield, MA 01085  
(413) 562-9631 • FAX: (413) 562-3799

www.smithboiler.com

◆ A MESTEK COMPANY



Log on to [www.smithboiler.com](http://www.smithboiler.com) and get connected to the Smith Heating Pros SPECifier. Fast, browser-based, easy-to-use program provides dynamically generated specifications, Auto-Cad drawings and more for Smith commercial boilers.