

INSTALLER
READ THESE INSTRUCTIONS CAREFULLY. THEY WILL
SAVE TIME IN ASSEMBLING BOILER

19A/19HE SERIES BOILER INSTALLATION INSTRUCTIONS



STEAM OR WATER HEATING
PRESSURIZED FOR FIRING OIL, GAS
OR COMBINATION GAS/OIL



DESIGNED AND TESTED ACCORDING TO THE A.S.M.E.
BOILER AND PRESSURE VESSEL CODE, SECTION IV
FOR MAXIMUM ALLOWABLE WORKING PRESSURE.
STEAM - 15 PSIG, WATER - 80 PSIG
CANADA: STEAM - 15 PSIG, WATER - 50 PSIG

CAUTION

Do not use automotive anti-freeze in boiler waterways. If necessary to use anti-freeze, be sure to employ a preparation designed for hydronic heating systems such as ethylene or propylene glycol.

Water treatment is not recommended. This boiler uses gaskets to seal the ports of adjoining sections. These gaskets are made of a fluorocarbon elastomer (designation FKM) marketed under the brand name Viton. Consult a water treatment professional before adding any chemical to the boiler water. Any water treatment or anti-freeze added to the system must be compatible with the Viton gaskets.

THE SECTIONS OF THIS BOILER MUST BE ASSEMBLED
TO THE PROPER TORQUE. READ INSTRUCTIONS

THESE INSTRUCTIONS TO BE LEFT WITH THE BOILER FOR REFERENCE PURPOSES

Smith
 CAST IRON BOILERS

WESTCAST, INC.
 260 NORTH ELM STREET WESTFIELD, MA 01085
 TEL. (413) 562-9631 FAX (413) 562-3799

19A/19HE SERIES BOILER INSTALLATION INSTRUCTIONS

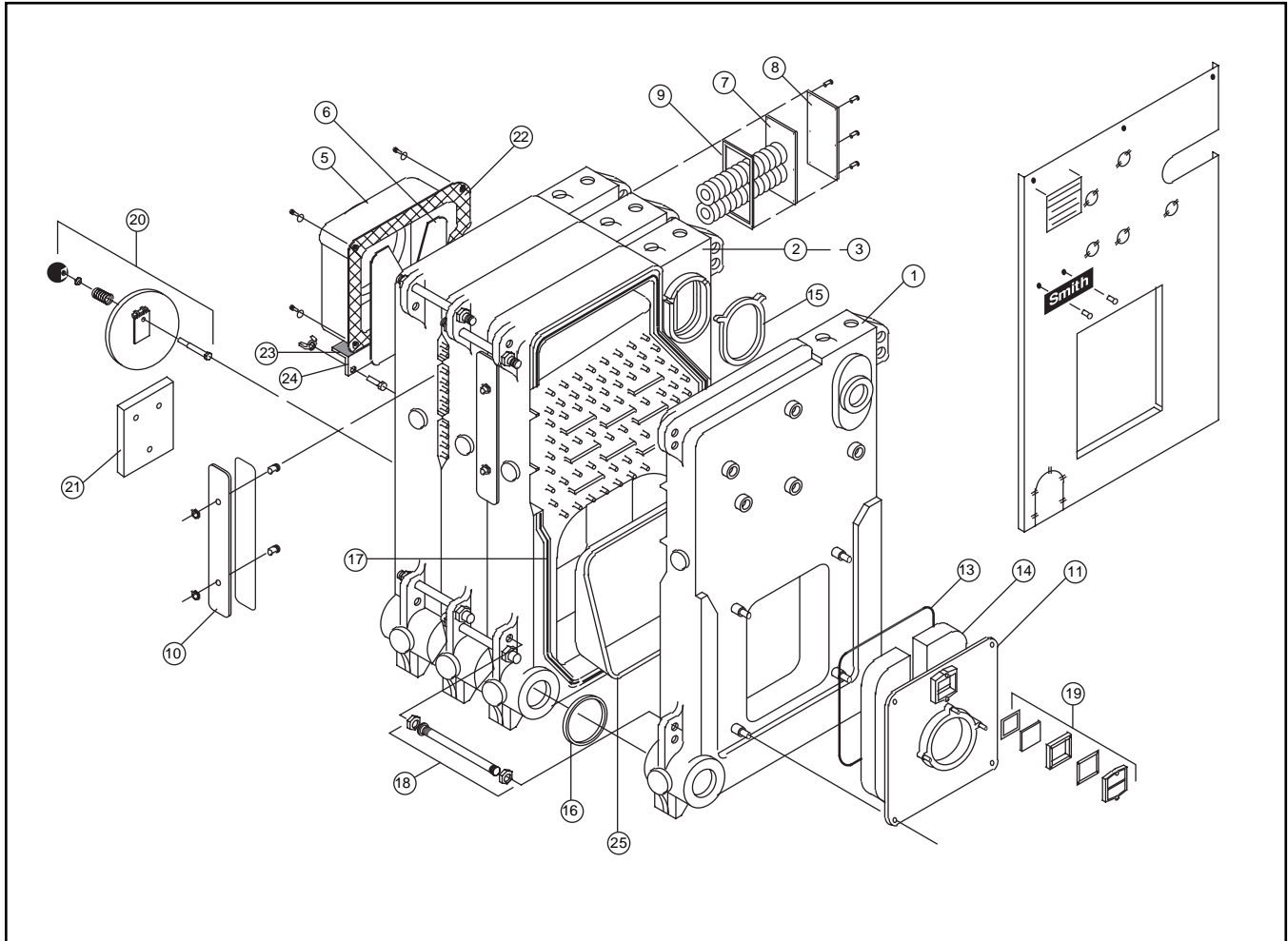

Item No.	Comp. No.	Description	Item No.	Comp. No.	Description
1	3638	Front Section	13	78105	Burner Mounting Plate Rope, 1/4" x 4.75'
2	3637	Intermediate Section, Plain	14	60434	Burner Mounting Plate Insulating Block
3	3641	Intermediate Section, Heater (Optional)	14	60430	Burner Mounting Plate Insulating Block (Beckett Burner 3-6 Section)
4	3639	Back Section	15		Upper Port Hydronic Seal
5	70338	Smokehood 7"	16		Lower Port Hydronic Seal
	70339	Smokehood 8"	17	60025	Insulating Ceramic Rope
	70340	Smokehood 9"	18	—	Tie Rod & Hardware
	70341	Smokehood 10"	19	—	Front Observation Port
		<i>Includes: Smokehood, Slide Damper, Angle Bracket Hardware</i>	20	70614	Rear Observation Port Assembly
6	69370	Slide Damper	21	3679	Rear Observation Port Cover Plate - 3, 4, 5, 6 Section Boilers
7	50634	Tankless Coil w/Gasket & Hardware (For Intermediate Heater Sections Only)	22	74300	Insulating Bolt Hole Tape 3' 6"
8	3572	Heater Cover Plate, Blank	23	74302	Insulating Tape 11"
9	60312	Heater Cover Plate Gasket	24	69150	Angle Bracket
10	01-3706	Cleanout Cover Plate	25	69761	Target Wall - 3, 4, 5, 6 Section Boilers
11		Burner Mounting Plate,			
	70465	6 1/8" Opening			
	70466	7 3/4" Opening			
	70491	9 1/8" Opening			
		<i>Includes: Mounting Plate w/Observation Glass and Cover</i>			

19A/19HE SERIES BOILER INSTALLATION INSTRUCTIONS

TABLE OF CONTENTS

SECTION	DESCRIPTION	PAGE		SECTION	DESCRIPTION	PAGE
	19A/19HE SERIES ISOMETRIC DRAWING	2		10	TANKLESS HEATERS	6
	PARTS LIST	2		11	SMOKEHOOD	6
	TABLE OF CONTENTS	3		12	BURNER MOUNTING PLATE	7
1	GENERAL INFORMATION	3		13	CLEANOUT COVERS	8
2	BOILER LOCATION	3		14	REAR OBSERVATION PORT	8
3	CODES AND REGULATIONS	3		15	CONTROL LOCATIONS	8
4	CHIMNEY AND BREECHING	3		16	JACKET	8
5	COMBUSTION AND VENTILATION AIR	4		17	SAFETY AND RELIEF VALVES	8
6	ASSEMBLY OF SECTIONS	4		18	CLEANING BOILER WATERWAYS	9
7	HYDROSTATIC TEST	5		19	OWNER'S INSTRUCTIONS	9
8	STEAM PIPING	5			CONTROL TAPPINGS DIAGRAM	10
9	WATER PIPING	6			WARNING	11

1. GENERAL

19A/19HE Series boilers are wet-base, extended surface, vertical flue design with integral cast flue gas collector for pressurized firing with oil, gas or combination power burners. Upper and lower port hydronic seals are of a special material resistant to petroleum products and compatible with ethylene and propylene based anti-freeze (non automotive type) which does not contain corrosion inhibitors to protect aluminum. The flue gas joints between sections, etc. are sealed using high temperature (2300°F) ceramic fiber rope. Access to the heating surface for cleaning is provided from the left hand side of the boiler through large cast iron cover plates. A slide damper is provided in the flue gas outlet for back pressure adjustment.

The boilers are supplied completely knocked down for field assembly, as factory assembled blocks of sections or completely assembled boiler-burner units. All items should be inspected for damage upon receipt, and any damage reported to the wholesaler and trucker. All components should be stored in a clean, dry area.

The boilers are conservatively rated for high efficiency performance with capability for down-firing to match connected load. The large OBOUND upper port provides transfer area above the water surface for dry steaming at full load.

2. BOILER LOCATION

The boiler must be installed on a smooth, level, non-combustible floor or pad as close to the chimney or vent location as possible to minimize breeching length. Allow clearance around the boiler for piping, service, maintenance, cleaning and tankless coil removal. Approximately 30 inches on the sides is a minimum (Check local code requirements). Do not install electrical conductors in floor or pad under boilers.

See FIGURE 1 for boiler floor pad requirements, and TABLE 1 for minimum required pad length.

TABLE 1

Boiler No.	Min. Recommended Pad Length
19-*-3	30"
19-*-4	36"
19-*-5	42"
19-*-6	48"
19-*-7	54"
19-*-8	60"
19-*-9	66"
19-*-10	72"
19-*-11	78"
19-*-12	84"

3. CODES AND REGULATIONS

All work in connection with the boiler, burner and controls must be performed in strict accordance with requirements of state and local authorities having jurisdiction over boiler installations.

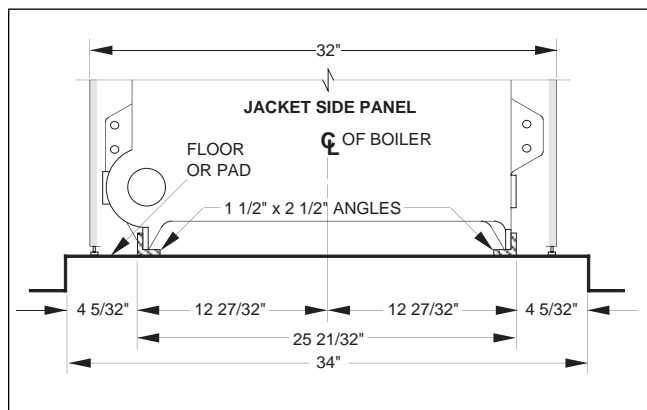

FIGURE 1

In the absence of such local requirements, the following should govern:

- A.S.M.E. Section IV - "Heating Boilers"
- A.S.M.E. Section VI - "Care and Operation of Boilers"
- ANSI/NFPA 31 - "Installation of Oil Burning Equipment"
- ANSI/Z223.1 - "National Fuel Gas Code"
- ANSI/NFPA 70 - "National Electrical Code"

4. CHIMNEY AND BREECHING

The breeching connection between boiler and chimney should be as direct as possible with the minimum number of elbows or bends. It should pitch upwards to the chimney at a rate of 1/4 inch per foot of horizontal run. Generally, the breeching and chimney should be the same diameter as the boiler outlet connection.

NOTE

11 and 12 section uses adapter collar for connection to 12" diameter vent system.

For fuel conservation and stable burner performance, the vent connection from the boiler should not include a barometric draft control or other opening unless the venting system can develop an excessive draft, or is required by code.

19A/19HE SERIES BOILER INSTALLATION INSTRUCTIONS

5. COMBUSTION AND VENTILATION AIR

An adequate supply of air for the boiler room must be provided to allow complete combustion of fuel and ventilation of the room to avoid excessively high ambient temperature. Air inlet by natural ventilation directly from the outside shall have total free area of not less than one sq. in. per 14,000 BTU per hour of input of all fuel burning appliances in the boiler room.

Where combustion air must be obtained through ducts, see ANSI/NFPA 31 or ANSI Z223.1 for requirements.

If mechanical combustion air supply is required, the system must be approved by the local authorities, and should provide at least 30 CFM per gallon of oil and 0.25 CFM per MBH of gas input to the boilers.

Ventilation air, if required, must be in addition to the combustion air quantities called for above.

6. ASSEMBLY OF SECTIONS

When boilers are delivered to the job site, each item should be inspected closely for possible shipping damage. Scars or nicks in the port sealing surfaces may allow leakage. **Do not attempt to use any section that has been damaged in the port seal area.**

When ready to commence assembly, recommended on a level pad, place the angle rails in position parallel with each other with the 2" legs on the floor and measuring 25-21/32 inches outside dimension. Be sure to align the center of the boiler with the center line of the pad. If no pad is provided, shim and grout under the angles to make them level and provide support along the full length. See FIGURE 1. Clean hydronic gasket recesses and rope groove with a wire brush, taking care not to damage machine surface.

See TABLE 2 for proper location of sections.

TABLE 2

3 SECT	F	H	B																
4 SECT	F	P	H	B															
5 SECT	F	H	P	H	B														
6 SECT	F	P	H	P	H	B													
7 SECT	F	H	P	H	P	H	B												
8 SECT	F	P	H	P	H	P	H	B											
9 SECT	F	P	H	P	H	P	H	P	B										
10 SECT	F	P	P	H	P	H	P	H	P	B									
11 SECT	F	P	P	P	H	P	H	P	H	P	B								
12 SECT	F	P	P	P	P	H	P	H	P	H	P	B							

F = Front Section
 P = Plain intermediate section
 H = Heater intermediate section-Optional, must be ordered.
 B = Back Section

CAUTION

Due to the fact that the sections are top heavy, it is absolutely necessary that the back section be supported in such a manner as to prevent its falling and causing potential serious bodily injury while preparing to add the next section. One such way would be to insert a piece of 3" x 36" piping in the lower port.

NOTE

Some sections may need shims under support feet to align with other sections.

Stand the back section in place with the feet on and in the angle iron rails. Support the section as required to prevent it from falling forward or rearward. Clean hydronic gasket recesses and rope groove with a stiff wire brush. Apply spray-on adhesive (supplied with the boiler) to rope groove to hold wicking in place during assembly.

CAUTION

Do not spray adhesive into the hydronic seal ports.

Apply a length of wicking avoiding bends and twists. Be sure ends extend past the cleanout cover opening. (See FIGURE 2) Place the upper and lower hydronic seals in the recessed section taking care not to dislodge the rope or the hydronic seals. Inspect the alignment of the sections through the open ports and, if properly aligned, install the draw rods with nuts drawn hand-tight. (See FIGURE 3.) Plumb the sections before applying torque to the upper right and lower left draw rods. Maintain finger-tight torque on upper left and lower right draw rods.

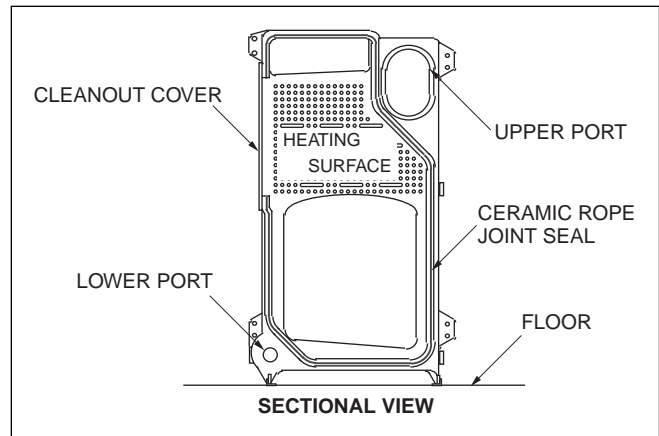

FIGURE 2

IMPORTANT

The upper and lower ports should be drawn up metal to metal around the outside of the hydronic seal. Metal to metal conditions will not occur at any other location. Avoid excessive torque on upper left and lower right draw rods, which may warp the section. See FIGURE 3 for correct alignment of the seal.

Assemble additional sections as described above.

After draw rods are hand tight, torque as shown in TABLE 3.

19A/19HE SERIES BOILER INSTALLATION INSTRUCTIONS

TABLE 3		
STEP 1	UPPER RIGHT	5 FT. LBS.
STEP 2	LOWER LEFT	5 FT. LBS.
STEP 3	UPPER LEFT	5 FT. LBS.
STEP 4	LOWER RIGHT	5 FT. LBS.
STEP 5	UPPER RIGHT	25 FT. LBS.
STEP 6	LOWER LEFT	25 FT. LBS.
STEP 7	UPPER RIGHT	50 FT. LBS.
STEP 8	LOWER LEFT	50 FT. LBS.
STEP 9	UPPER LEFT	10 FT. LBS.
STEP 10	LOWER RIGHT	10 FT. LBS.

Prepare additional intermediate sections and install in the same manner described above. Be sure each section is properly sealed against water leakage and flue gas exfiltration. Be certain the angle rails remain level and provide support for each section as it is assembled. Check each section for vertical position.

When all sections, including the front section or back are in place, check all draw rods to insure iron-to-iron contact at ports. **DO NOT APPLY EXCESSIVE TORQUE.** See TABLE 3 for recommended torques.

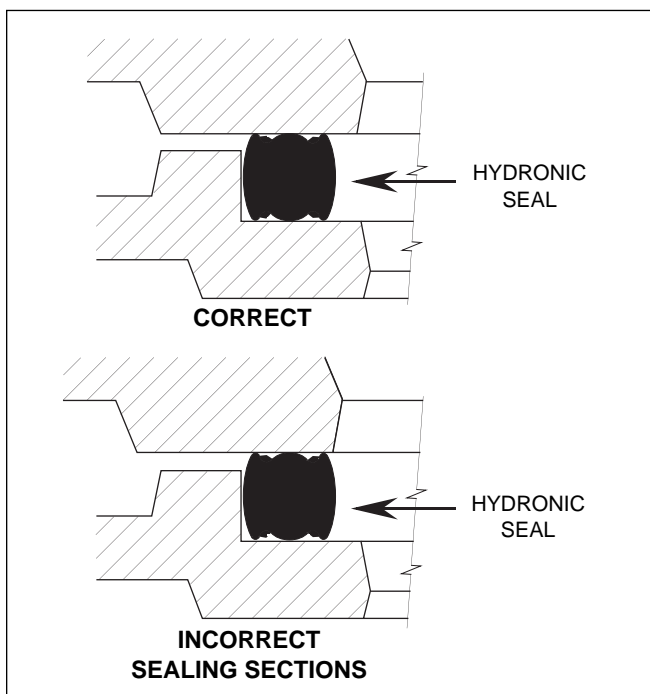

FIGURE 3

7. HYDROSTATIC TEST

Plug tappings, fill boiler with water and vent air from top of boiler. Check for leaks. Leakage at seals may be due to misalignment of hydronic seals. Loosen draw rods, reposition seals and retest as above.

All completed boilers shall satisfactorily pass the hydrostatic tests as prescribed by A.S.M.E., Code Section IV.

1. Steam Boilers – The assembled boiler shall be subjected to a hydrostatic test of not less than 45 PSIG.

2. Water Boilers – The assembled boiler shall be subjected to a hydrostatic test pressure not less than 1-1/2 times the maximum allowable working pressure.

3. The required test shall not exceed the test pressure by more than 10 PSI.

Excessive torque on draw rods may damage castings. Do not exceed the torque shown in TABLE 3.

In a cold environment, hydronic seals may not quickly conform to sealing surfaces when properly compressed. Under such conditions, hydrostatic testing with cold water might show weeping or leaking at the seals. To avoid this possibility, delay filling the boiler with cold water for a few hours after assembly, or use warm water, if available, for the tests.

If there is seepage about chaplets or minor leakage, consult the Smith Company representative for advice regarding A.S.M.E. Code approved repairs by peening or plugging.

8. STEAM PIPING

A steam piping schedule is shown in TABLE 4. Pitch piping to allow condensate to flow in the same direction as steam. Makeup water connections must be made to the return piping, not directly to the boiler. Install blow-down valves as required.

See FIGURE 4 for recommended acceptable steam piping arrangement.

TABLE 4			
BOILER SIZE	NO. OF 3" RISERS	HEADER	EQUALIZER
3 THRU 5 SECTION	1	3"	1-1/2"
6 THRU 10 SECTION	2	4"	2"
11 AND 12 SECTION	2	5"	2-1/2"

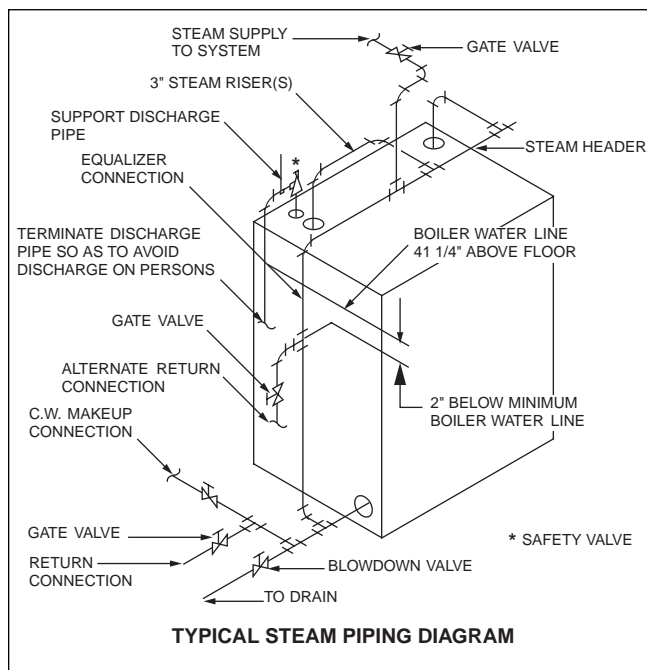

FIGURE 4

19A/19HE SERIES BOILER INSTALLATION INSTRUCTIONS

TABLE 5				
NUMBER OF SECTIONS	EVAPOR. RATE GPM	WATER 1" BELOW WATER LEVEL GAL.	MIN. FEED WATER PUMP RATE-GPM	CONDENSATE RECEIVER CAP.-GAL.
3	.61	1.4	1.22	12
4	.85	1.9	1.70	16
5	1.19	2.4	2.37	22
6	1.52	2.9	3.04	29
7	1.86	3.3	3.71	35
8	2.19	3.8	4.38	41
9	2.53	4.3	5.05	47
10	2.86	4.8	5.72	54
11	3.20	5.2	6.39	60
12	3.53	5.7	7.06	66

Feed water makeup requirements.

NOTE

These recommendations are considered normal for compact buildings on the basis of 80% receiver use. Where buildings are spread out, additional receiver capacity may be necessary because of the extended time required for condensation to return to the receiver.

9. WATER PIPING

See FIGURE 5 for acceptable water piping diagram. TABLE 6 gives pumping rate and supply & return sizing for standard installations.

TABLE 6			
BOILER SIZE	GPM	RETURN CONN.	SUPPLY CONN.
3	30	2"	2"
4	41	2"	2"
5	58	2-1/2"	2-1/2"
6	74	3"	3"
7	90	3"	3"
8	106	3"	3"
9	123	3"	3"
10	139	3"	3"
11	155	3"	4"
12	171	3"	4"

Based on 20°F system temperature drop.

NOTE

Boiler supplied with 4" water supply tapping and 3" return tapping.

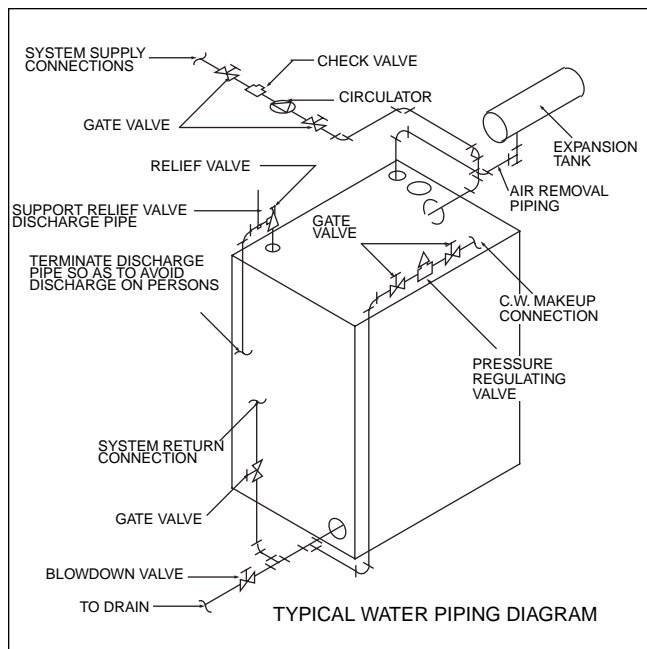

FIGURE 5

10. TANKLESS HEATERS

Heater openings are provided for below-the-water-line tankless heater coils in all special intermediate sections when ordered. See TABLE 2 for the correct placement of these heater sections. Install the low limit temperature control in the 3/4" tap located in the center of the coil.

If the heater sections are installed in an order other than in TABLE 2 the jacket panels will not match.

11. SMOKE HOOD

Install smoke hood with the correct size smoke pipe connecting collar using the 5/16" x 1-1/2" studs and hex nuts furnished in screw seats in the back section. Apply self-adhesive insulating tape (Items 21 and 22 in Parts detail drawing on Page 2) to smoke hood flange and damper angle Item 23. Fasten the slide damper in the open position for starting the burner adjustment process.

See FIGURE 6 for recommended "L" coil piping and FIGURE 7 for SM9-18 single and/or dual piping arrangements.

19A/19HE SERIES BOILER INSTALLATION INSTRUCTIONS

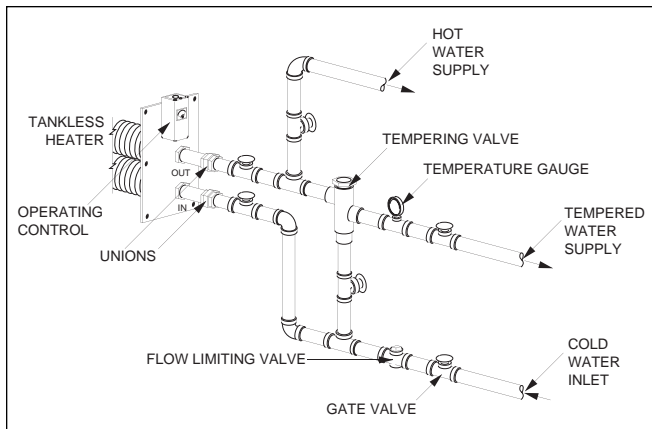

FIGURE 6 — TANKLESS PIPING

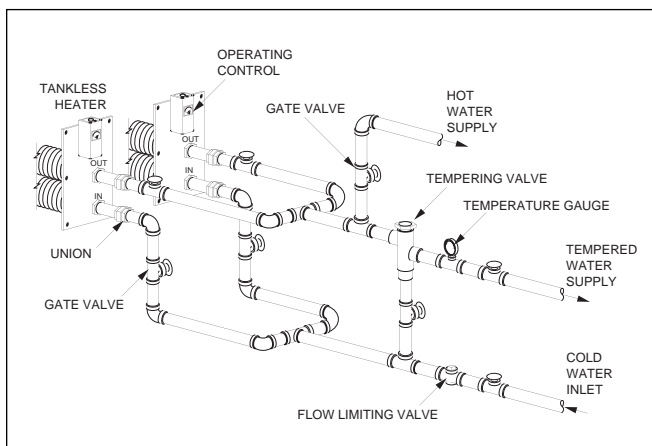

FIGURE 7 — DUAL TANKLESS PIPING

12. BURNER MOUNTING PLATE & TARGET WALL

The new **target wall** used on 3-6 section boilers must be positioned with the flat side tight against the **rear casting** and with the bottom side resting on the **floor** of the combustion chamber. No glues or fasteners are used to secure the target wall.

Each boiler is provided with a cast iron burner mounting plate with an appropriate burner opening and tapped holes for studs to accommodate burner flange. The mounting plate is furnished with 1/4" diameter sealing rope and an insulation block which should be installed on the plate before placing the plate on the boiler. (See exploded view on page 2, Items 11-13 & FIGURE 8.)

The sealing rope should be placed in the groove on the boiler side of the plate using adhesive to hold it in place. The insulation block has a burner opening and a cutout for the observation opening. Locate the block with the high temperature facing on the fire side in the opening in the front section. The burner mounting plate **insulating block** for Beckett burners is installed with the dished side facing **towards** the combustion chamber.

Attach the block to the plate with the four 1/4" x 5" machine screws and 1-1/2" O.D. washers, the washers on the insulation block side. At the time of burner installation, the hole in the insulation block may have to be enlarged. See separate burner installation booklet for further assistance and dimensions.

NOTE

Tighten burner mounting plate screws evenly to slightly compress rope gasket. Overtightening will cause plate cracking at corners.

NOTE

Most large burners require support to the floor. See burner manufacturer's manual for such specifications if needed.

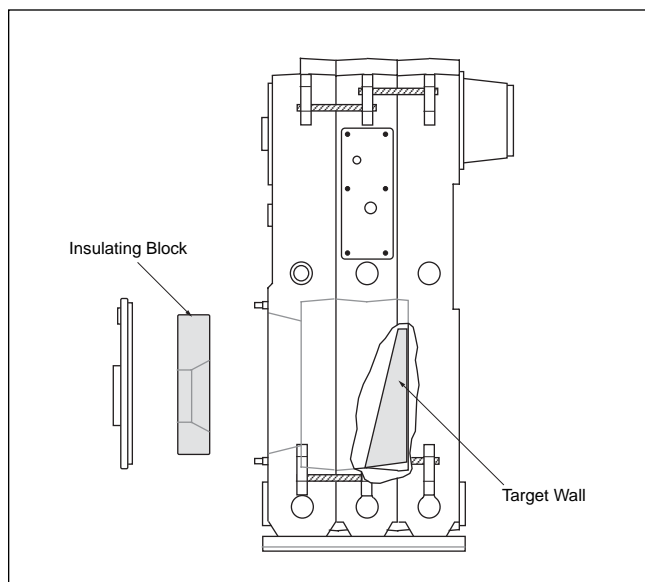

FIGURE 8

19A/19HE SERIES BOILER INSTALLATION INSTRUCTIONS

13. CLEANOUT COVERS

Be sure the rope seals are in place around the groove in the cleanout cover plate. Install the plates on the boiler sections carefully to insure proper sealing all around, using the 5/16" x 2" special anchor bolt and 5/16" hex head nuts. After periodic flue cleaning, replace nuts at 10 lbs. torque. Use Hi-Temp silicone caulk to seal covers air-tight.

14. REAR OBSERVATION PORTS 7-12 SECTIONS INSTRUCTIONS FOR ASSEMBLY:

1. Locate steel "flapper door" (Item 6) as shown in FIGURE 9 below. Drive Item 7, "expansion pin", into hole in Item 1 to secure 6 in position.
2. Lift Item 6 up and install Item 2, "hex bolt".
3. Slide Item 3, "compression spring" over the hex bolt and screw Item 4 "hex nut" to hex bolt.
4. Screw Item 5, "ball knob" into position and lock location using Item 4 as a "jam" nut.
5. Adhere 24-1/2" insulating tape as shown to Item 1.6. Mount assembly to back section of boiler.
7. 3-6 section boilers use a solid cover which is installed the same way.

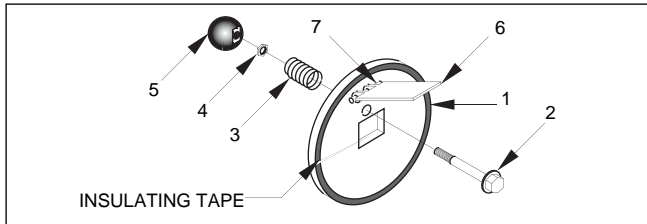

FIGURE 9

IMPORTANT

Item 6 must always be part of the assembly. Check condition twice a year and replace as needed.

15. CONTROL LOCATIONS

NOTE

Jacket front panel should be in place before controls on front of front section are installed.

Refer to FIGURE 11 showing locations recommended for steam and water boiler limit and operating controls. Note the requirement for an operating temperature control whenever a tankless heater is called for. This is in addition to pressure limit controls and other operating controls on steam boilers.

NOTE

On steam boilers the 1" close nipple and 1" x 1/4" reducing coupling for operating control should be installed prior to jacket top panels.

16. JACKET

Jacket assembly details are contained in a separate instruction booklet.

17. SAFETY AND RELIEF VALVES

Safety and relief valves sized on the output rating of each boiler size are furnished along with the necessary pipe and fittings for installation in the back section. The valve discharge connections should be piped to a location where people will not be exposed to hot vapor or liquid. Any discharge piping should be supported so as to prevent exerting any strain on the valve body by the weight of the piping. See FIGURE 10.

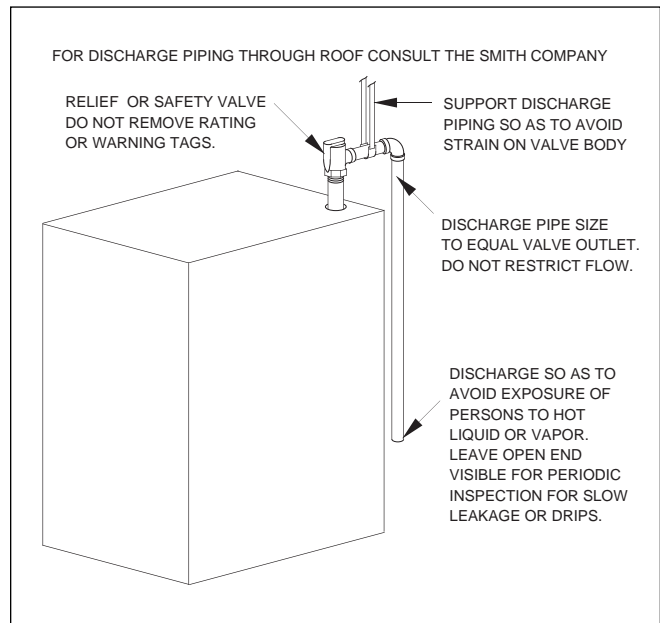

FIGURE 10

Some state and local codes require steam safety valves be piped to the atmosphere outside the building.

19A/19HE SERIES BOILER INSTALLATION INSTRUCTIONS

18. CLEANING BOILER WATERWAYS

A. STEAM BOILERS

NOTE

The boiler should be cleaned before connecting system piping and installing steam trim.

1. Plug unused openings all around the boiler leaving a valved overflow pipe connected to the safety valve tapping. Also provide a valved blow-down connection to one of the bottom tappings.
2. The fuel burning equipment should be installed and made ready to operate in accordance with the burner instructions.
3. Fill the boiler with water to the middle of the upper port, adding a boiler cleaning compound, as recommended in A.S.M.E. Section VI.
4. Fire the boiler for at least one hour at a low rate to circulate the cleaning compound through the boiler.
5. Blow off surface of boiler water through skimmer connection or through safety valve opening by feeding clean water into the boiler through a bottom fill connection.
6. When the water coming off the surface runs clear, shut off the burner, close the top valve and open the bottom blow-down valve. If there is a slight steam pressure in the boiler, it will assist the blow-down.
7. When the sections have cooled after blow-down, flush the interior of the boiler from the top by introducing water from a hose through the top port. When the water runs clear, complete the system piping, install the steam trim and controls. Fill the boiler with clean water. Heat the boiler water to at least 180°F to release corrosive gases.

B. WATER BOILERS

NOTE

The system piping should be completed before cleaning the boiler.

1. Add an approved boiler compound. Follow the compound manufacturer's instructions for best results. Fill the system and vent air wherever necessary.
2. Heat the water to at least 180°F and circulate through all the piping system. After about one hour, drain the system thoroughly. Wash the interior of the boiler with a hose inserted through the top tapping. When blow-down water runs clean, allow boiler to cool, then fill the system with clean water.
3. Heat the water up to about 180°F and vent air as necessary to purge the system. The boiler is now ready to operate.

19. OWNERS INSTRUCTIONS

A. For best performance of the boiler, the following suggestions should be performed by a qualified boiler room technician, through a regular program of maintenance and adjustment to obtain the following.

1. Oil burner combustion: 12 to 12 1/2 + % CO₂, zero smoke, smooth lightoff and operation.

Gas burner combustion: 10 to 10 1/2% CO₂, 0.02% CO, smooth lightoff and operation.
 2. Keep boiler fireside surface clean. Flue gas temperature reading above 450°F over boiler room temperature signals the start of soot accumulation. Inspect at least twice each year.
 3. Steam boiler water condition should be observed. Unstable water line, system steam hammer indicate dirty water. Blow-down is recommended. However, the introduction of excess raw water to a steam boiler can result in the deposit of scale and inefficient operation or physical damage to the boiler.
 4. Float operated and probe type low water cutoff devices should be maintained according to the instructions of the manufacturer.
 5. Limit control function should be checked on a regular basis.
 6. Flame safeguard controls should be checked regularly.
- B. The products of combustion must be conducted to the outdoors by means of a metal connector of at least the same size as the boiler smokehood outlet and a chimney or stub-stack. The boiler is constructed for pressurized operation and the burners are selected for operation against a back pressure of 0.10 ins. w.c. at the boiler outlet. If the actual conditions cause a back pressure in excess of 0.10 ins. w.c. at the boiler outlet, consult the Smith Co. for verification of burner size. If the chimney has the ability to develop excess draft, a barometric draft control should be installed in the chimney. Check with the Smith representative for assistance.

19A/19HE SERIES BOILER INSTALLATION INSTRUCTIONS

SERIES 19A/19HE BOILER (STEAM) TAPPING AND CONTROL LOCATIONS

- "A" - 1" TAP, PRESSURE CONTROLS
- "B" - 1 1/4" TAP, STEAM SAFETY VALVE
- "C" - 1" TAP, OPTIONAL LWCO
- "D" - 3/4" TAP

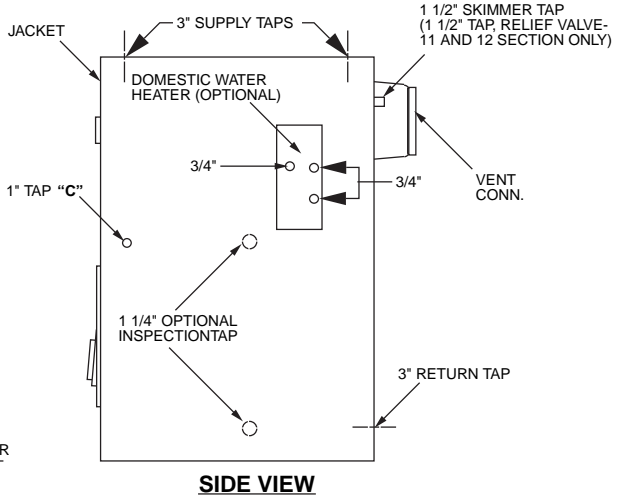
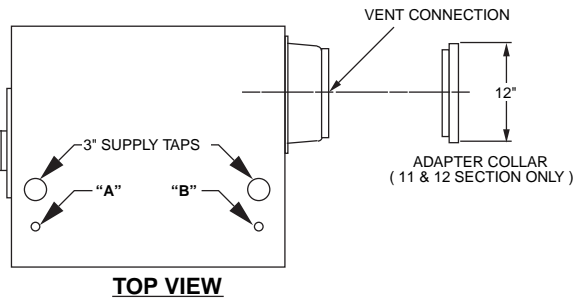
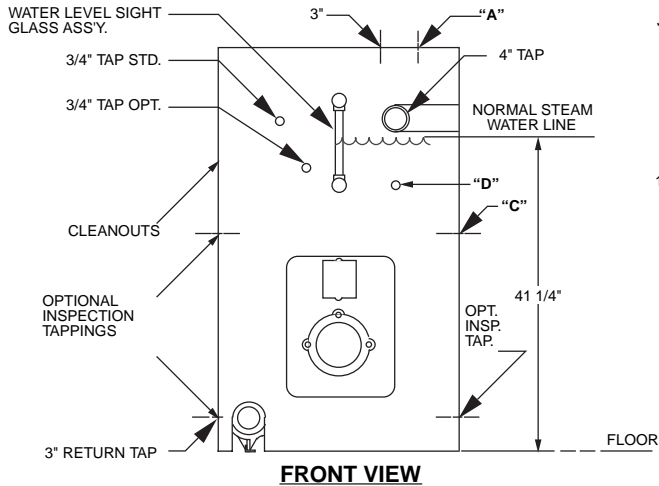

SERIES 19A/19HE BOILER (WATER) TAPPING AND CONTROL LOCATIONS

- "A" - 1" TAP, AIR REMOVAL CONN., OPT LWCO
- "B" - 1 1/4" TAP, SAFETY VALVE
- "C" - 1" TAP, OPTIONAL LWCO
- "D" - 3/4" TAP, OPER. TEMP. CONN.

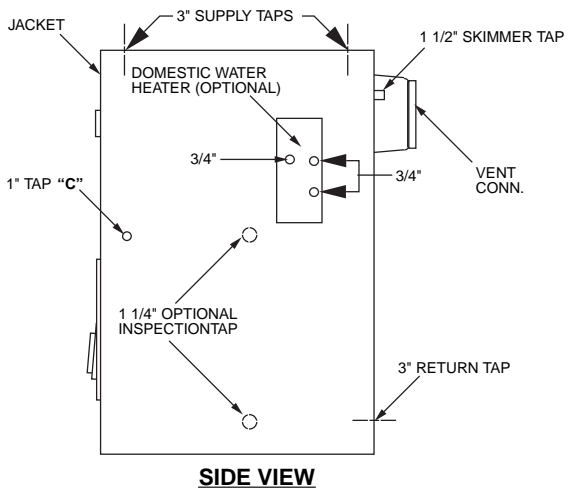
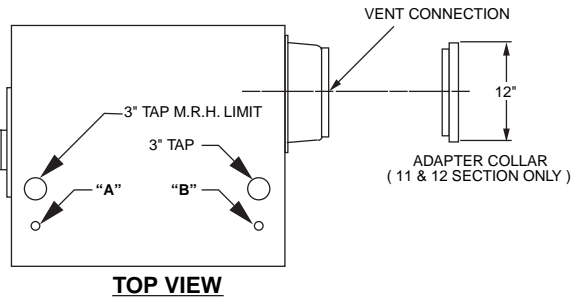
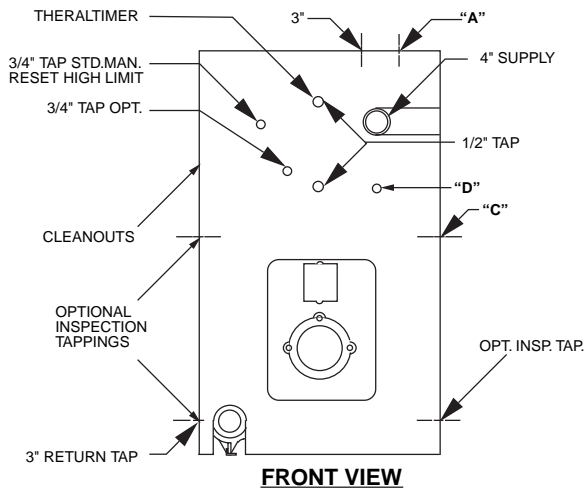

FIGURE 11

19A/19HE SERIES BOILER INSTALLATION INSTRUCTIONS

WARNING

Any appliance that burns natural gas, propane gas, fuel oil, wood or coal is capable of producing carbon monoxide (CO).

Carbon Monoxide (CO) is a gas which is odorless, colorless and tasteless but is very toxic.

If your Smith boiler is not working properly, or is not vented properly, dangerous levels of CO may accumulate. CO is lighter than air and thus may travel throughout the building. **BRIEF EXPOSURE TO HIGH CONCENTRATIONS OF CO, OR PROLONGED EXPOSURE TO LESSER AMOUNTS OF CO MAY RESULT IN CARBON MONOXIDE POISONING.**

EXPOSURE CAN BE FATAL AND EXPOSURE TO HIGH CONCENTRATIONS MAY RESULT IN THE SUDDEN ONSET OF SYMPTOMS INCLUDING UNCONSCIOUSNESS.

Symptoms of CO poisoning include the following:

dizziness
headaches
nausea

vision problems
loss of muscle control
weakness

shortness of breath
unclear thinking
unconsciousness

The symptoms of CO poisoning are often confused with those of influenza, and the highest incidence of poisoning occurs at the onset of cold weather or during flu season. A victim may not experience any symptoms, only one symptom, or a few symptoms. Suspect the presence of carbon monoxide if symptoms tend to disappear when you leave your home.

The following signs may indicate the presence of carbon monoxide:

- Hot gases from appliance, venting system, pipes or chimney, escaping into the living space.
- Flames coming out around the appliance.
- Yellow colored flames in the appliance.
- Stale or smelly air.
- The presence of soot or carbon in or around the appliance.
- Very high unexplained humidity inside the building.

If any of the symptoms of CO poisoning occur, or if any of the signs of carbon monoxide are present, **VACATE THE PREMISES IMMEDIATELY AND CONTACT A QUALIFIED HEATING SERVICE COMPANY OR THE GAS COMPANY OR THE FIRE DEPARTMENT.**

To reduce the risk of CO poisoning, have your heating system "tuned up" by a licensed heating contractor or the gas company -- preferably before each heating season. Also have the service company check your chimney or vent pipes for blockage.

Your home should also be adequately ventilated, particularly if you have insulated your home.

ONLY QUALIFIED, LICENSED SERVICE CONTRACTORS SHOULD PERFORM WORK ON YOUR SMITH BOILER.

WARNING

Install, operate and maintain unit in accordance with manufacturer's instructions to avoid exposure to fuel substances or substances from incomplete combustion which can cause death or serious illness. The State of California has determined that these substances may cause cancer, birth defects, or other reproductive harm. Also, install and service this product to avoid exposure to airborne particles of glasswool fibers and/or ceramic fibers known to the State of California to cause cancer through inhalation.

Smith
CAST IRON BOILERS

WESTCAST, INC.
260 NORTH ELM STREET WESTFIELD, MA 01085
TEL. (413) 562-9631 FAX (413) 562-3799