

Outdoor Sensor 070

The tekmar Outdoor Sensor 070 includes a 10 kΩ thermistor which provides an accurate measurement of the outdoor temperature. The 070 sensor is protected by a white U.V. resistant PVC plastic enclosure.



Universal Sensor Enclosure 080

The tekmar Universal Sensor Enclosure 080 provides a housing for the 071 sensor. The 080 also allows conduit to run directly to the sensor. The 080 enclosure is flame-retardant and can withstand the high temperatures commonly found in hydronic systems.



Universal Sensor 071/078/082

The tekmar Universal Sensors have brass sleeves for fast response and a wide operating range. These sensors can be used in a multitude of applications.

- Universal Sensor 071 is supplied with 12 in (300 mm) of two conductor wire.
- Universal Sensor 078 is supplied with 15 ft (4572 mm) of two conductor cable.
- Universal Sensor 082 is supplied with 8 ft (2438 mm) of two conductor wire.

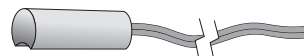
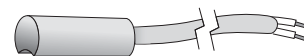
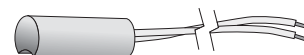

Installation — Outdoor Sensor 070

STEP ONE — MOUNTING THE SENSOR

Note: The temperature sensor (thermistor) is built into the 070 enclosure.

- Remove the screw and pull the front cover off the sensor enclosure.
- The 070 can either be mounted directly onto a wall or a 2" x 4" electrical box. When the 070 is wall mounted, the wiring should enter through the back or bottom of the enclosure. Do not mount the 070 with the conduit knockout facing upwards as rain could enter the enclosure and damage the sensor.

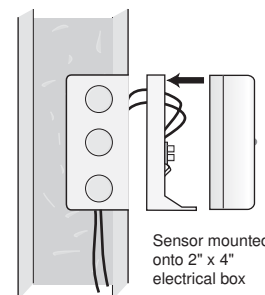
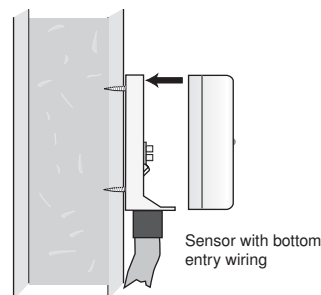
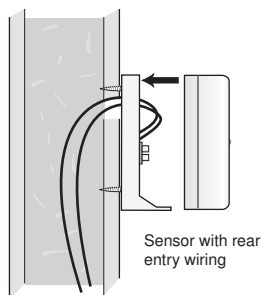

- In order to prevent heat transmitted through the wall from affecting the sensor reading, it may be necessary to install an insulating barrier behind the enclosure.
- The 070 should be mounted on a wall which best represents the heat load on the building (a northern wall for most buildings and a southern facing wall for buildings with large south facing glass areas). The 070 should not be exposed to heat sources such as ventilation or window openings.
- The 070 should be installed at an elevation above the ground that will prevent accidental damage or tampering.

STEP TWO — WIRING AND TESTING THE SENSOR

- Connect 18 AWG or similar wire to the two terminals provided in the enclosure and run the wires from the 070 to the control. Do not run the wires parallel to telephone or power cables. If the sensor wires are located in an area with strong sources of electromagnetic interference (EMI), shielded cable or twisted pair should be used or the wires can be run in a grounded metal conduit. If using shielded cable, the shield wire should be connected to the Com or Com Sen terminal on the control and not to earth ground.
- Follow the sensor testing instruction in this brochure and connect the wires to the control.
- Replace the front cover of the sensor enclosure

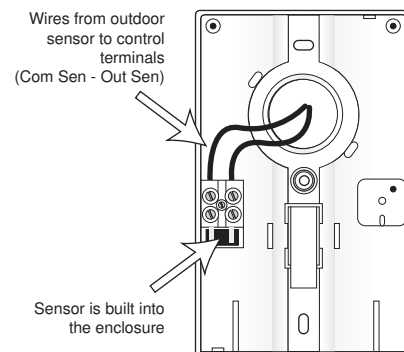

Installation — Universal Sensors 071, 078 & 082

STEP ONE — MOUNTING THE SENSOR

Note: These sensors are designed to mount on a pipe or in a temperature immersion well.

The Universal Sensor can be strapped directly to the pipe using the cable tie provided. Insulation should be placed around the sensor to reduce the effect of air currents on the sensor measurement.

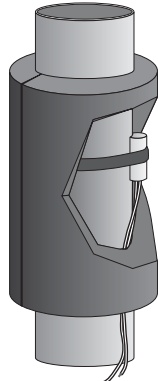

The Universal Sensor should be placed downstream of a pump or after an elbow or similar fitting. This is especially important if large diameter pipes are used as the thermal stratification within the pipe can result in erroneous sensor readings. Proper sensor location requires that the fluid is thoroughly mixed within the pipe before it reaches the sensor.

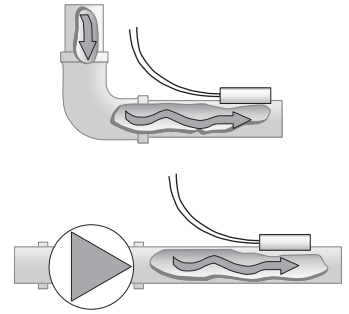

The stiff wire of the Universal Sensor 078 allows it to be inserted into deep temperature wells such as those found on domestic hot water (DHW) tanks.

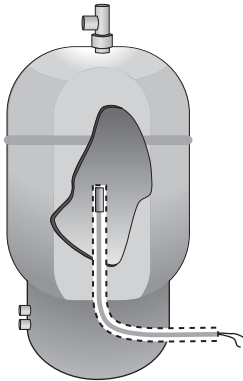

The Universal Sensor 078 can be used to measure slab temperature. The stiff wire of the Universal Sensor 078 allows it to be inserted into a conduit with a minimum 1/2 inch (12 mm) inside diameter. It is also possible to push the sensor around gentle bends in the conduit.

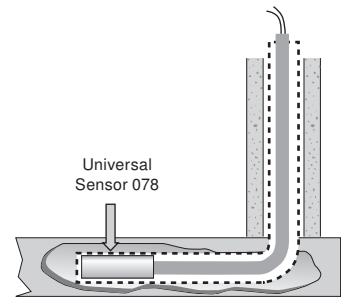

STEP TWO — WIRING AND TESTING THE SENSOR

Caution: Do not run sensor wires parallel to telephone or power cables. If the sensor wires are located in an area with strong sources of electromagnetic interference, shielded cable or twisted pair should be used or the wires can be run in a grounded metal conduit. If using shielded cable, the shield wire should be connected to the Com Sen terminal on the control and not to earth ground.

- If a Universal Sensor Enclosure 080 is used to mount the 071 or 082 follow the installation instructions provided below.
- Without the Universal Sensor Enclosure 080, it is necessary to connect 18 AWG wire to the two sensor wires. Marrettes can be used to hold the wires together.
- Follow the sensor testing instructions given in this brochure and then connect the wires to the control.

Installation — Universal Sensor Enclosure 080

If the sensor wires are run in conduit, a Universal Sensor Enclosure 080 can be used to mount the sensor and provide a connection for the conduit.



Mounting the 080 directly to a pipe.

The Sensor 071 or 082 is placed into the sensor block with the flat side of the sensor facing the pipe. The sensor and enclosure are strapped onto a 1" to 4" (25 to 100 mm) diameter pipe with the cable tie provided. Make sure there is good contact between the sensor and the pipe. Connect the sensor wires to the terminal block in the enclosure. The other side of the terminal block is used to connect the wires from the control.

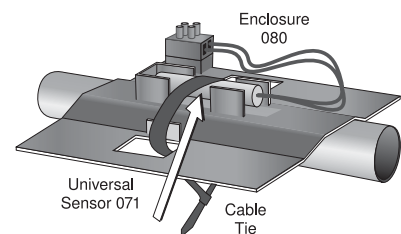

Using a Temperature Well

If a Universal Sensor is mounted onto 1" (25 mm) diameter L type copper pipe, there is approximately an 8 second delay between a sudden change in water temperature and the time the sensor measures the temperature change. This delay increases considerably when mild steel (black iron) pipe is used. In general, it is recommended that a temperature well be used for steel pipe of diameter greater than 1-1/4" (32 mm). Temperature wells are also recommended when large diameter pipes are used and fluid stratification is present.

The Universal Sensor 071 or 082 and Universal Sensor Enclosure 080 are specifically designed to mount onto a 3/8" (10 mm) ID temperature well that is supplied with an end groove. To install the well, plumb a 'T' into the pipe and fix the well into the 'T'. The 080 enclosure has a 7/8" (22 mm) back knockout that must be removed and fitted over the temperature well. The 071 is then inserted into the well and the retaining clip supplied with the enclosure is snapped onto the well end groove. If the well has a threaded end, the installer must supply a standard threaded conduit retaining ring. The two wires from the sensor are connected to the terminal block provided in the enclosure. The other side of the terminal block is used to connect wires from the control.

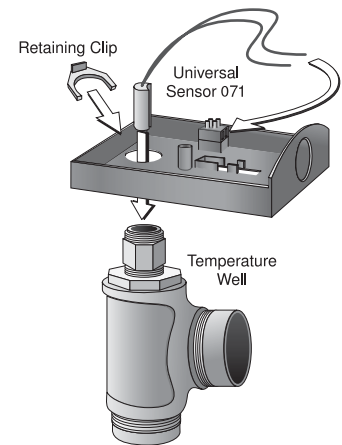

Sensor Testing Instructions

A good quality test meter capable of measuring up to 5,000 k Ω (1 k Ω = 1000 Ω) is required to measure the sensor resistance. In addition to this, the actual temperature must be measured with either a good quality digital thermometer, or if a thermometer is not available, a second sensor can be placed alongside the one to be tested and the readings compared.

First measure the temperature using the thermometer and then measure the resistance of the sensor at the control. The wires from the sensor must not be connected to the control while the test is performed. Using the chart below, estimate the temperature measured by the sensor. The sensor and thermometer readings should be close. If the test meter reads a very high resistance, there may be a broken wire, a poor wiring connection or a defective sensor. If the resistance is very low, the wiring may be shorted, there may be moisture in the sensor or the sensor may be defective. To test for a defective sensor, measure the resistance directly at the sensor location.

Do not apply voltage to a sensor at any time as damage to the sensor may result.

Temperature		Resistance	Temperature		Resistance	Temperature		Resistance	Temperature		Resistance
°F	°C	Ω	°F	°C	Ω	°F	°C	Ω	°F	°C	Ω
-50	-46	490,813	20	-7	46,218	90	32	7,334	160	71	1,689
-45	-43	405,710	25	-4	39,913	95	35	6,532	165	74	1,538
-40	-40	336,606	30	-1	34,558	100	38	5,828	170	77	1,403
-35	-37	280,279	35	2	29,996	105	41	5,210	175	79	1,281
-30	-34	234,196	40	4	26,099	110	43	4,665	180	82	1,172
-25	-32	196,358	45	7	22,763	115	46	4,184	185	85	1,073
-20	-29	165,180	50	10	19,900	120	49	3,760	190	88	983
-15	-26	139,402	55	13	17,436	125	52	3,383	195	91	903
-10	-23	118,018	60	16	15,311	130	54	3,050	200	93	829
-5	-21	100,221	65	18	13,474	135	57	2,754	205	96	763
0	-18	85,362	70	21	11,883	140	60	2,490	210	99	703
5	-15	72,918	75	24	10,501	145	63	2,255	215	102	648
10	-12	62,465	80	27	9,299	150	66	2,045	220	104	598
15	-9	53,658	85	29	8,250	155	68	1,857	225	107	553

Technical Data

Outdoor Sensor 070

Literature	— D 070
Packaged weight	— 0.35 lb. (160 g)
Enclosure	— Enclosure E, white PVC plastic
Dimensions	— 4-1/2" H x 2-7/8" W x 1-1/2" D (73 x 114 x 38 mm)
Approvals	— CSA C US, UL listed
Operating range	— -60 to 140°F (-50 to 60°C)
Sensor	— NTC thermistor, 10 kΩ @ 77°F (25°C ±0.2°C), β=3892

Universal Sensor 071

Literature	— D 070
Packaged weight	— 0.08 lb. (35 g)
Enclosure	— Brass sleeve, 12" (300 mm) 20 AWG XLPE wire
Dimensions	— 3/8" OD x 3/4" (9.5 OD x 19 mm)
Approvals	— CSA C US, UL listed
Operating range	— -60 to 255°F (-50 to 125°C)
Sensor	— NTC thermistor, 10 kΩ @ 77°F (25°C ±0.2°C), β=3892

Universal Sensor 078

Literature	— D 070
Packaged weight	— 0.44 lb. (200 g)
Enclosure	— Brass sleeve, 15' (4572 mm) 18 AWG 220°F (105°C) PVC jacketed 300 V wire
Dimensions	— 3/8" OD x 3/4" (9.5 OD x 19 mm)
Approvals	— CSA C US, UL listed
Operating range	— -60 to 221°F (-50 to 105°C)
Sensor	— NTC thermistor, 10 kΩ @ 77°F (25°C ±0.2°C), β=3892

Universal Sensor Enclosure 080

Literature	— D 070
Packaged weight	— 0.4 lb (175 g)
Enclosure	— Enclosure E, glass reinforced modified PET
Dimensions	— 4-1/2" H x 2-7/8" W x 1-1/2" D (73 x 114 x 38 mm)
Approvals	— CSA C US
Operating range	— -60 to 255°F (-50 to 125°C)
Sensor required	— tekmar type #: 071 or 082

Universal Sensor 082

Literature	— D 070
Packaged weight	— 0.44 lb. (200 g)
Enclosure	— Brass sleeve, 8' (2438 mm) 20 AWG zipcord, PVC insulated wire
Dimensions	— 3/8" OD x 3/4" (9.5 OD x 20 mm)
Approvals	— CSA C US, UL listed
Operating range	— -60 to 221°F (-51 to 105°C)
Sensor	— NTC thermistor, 10 kΩ @ 77°F (25°C ±0.2°C), β=3892

Limited Warranty and Product Return Procedure

Limited Warranty *The liability of tekmar under this warranty is limited. The Purchaser, by taking receipt of any tekmar product ("Product"), acknowledges the terms of the Limited Warranty in effect at the time of such Product sale and acknowledges that it has read and understands same.*

The tekmar Limited Warranty to the Purchaser on the Products sold hereunder is a manufacturer's pass-through warranty which the Purchaser is authorized to pass through to its customers. Under the Limited Warranty, each tekmar Product is warranted against defects in workmanship and materials if the Product is installed and used in compliance with tekmar's instructions, ordinary wear and tear excepted. The pass-through warranty period is for a period of twenty-four (24) months from the production date if the Product is not installed during that period, or twelve (12) months from the documented date of installation if installed within twenty-four (24) months from the production date.

The liability of tekmar under the Limited Warranty shall be limited to, at tekmar's sole discretion: the cost of parts and labor provided by tekmar to repair defects in materials and/or workmanship of the defective product; or to the exchange of the defective product for a warranty replacement product; or to the granting of credit limited to the original cost of the defective product, and such repair, exchange or credit shall be the sole remedy available from tekmar, and, without limiting the foregoing in any way, tekmar is not responsible, in contract, tort or strict product liability, for any other losses, costs, expenses, inconveniences, or damages, whether direct, indirect, special, secondary, incidental or consequential, arising from ownership or use of the product, or from defects in workmanship or materials, including any liability for fundamental breach of contract.

The pass-through Limited Warranty applies only to those defective Products returned to tekmar during the warranty period. This Limited Warranty does not cover the cost of the parts or labor to remove or transport the defective Product, or to reinstall the repaired or replacement Product, all such costs and expenses being subject to Purchaser's agreement and warranty with its customers.

Any representations or warranties about the Products made by Purchaser to its customers which are different from or in excess of the tekmar Limited Warranty are the Purchaser's sole responsibility and obligation. Purchaser shall indemnify

and hold tekmar harmless from and against any and all claims, liabilities and damages of any kind or nature which arise out of or are related to any such representations or warranties by Purchaser to its customers.

The pass-through Limited Warranty does not apply if the returned Product has been damaged by negligence by persons other than tekmar, accident, fire, Act of God, abuse or misuse; or has been damaged by modifications, alterations or attachments made subsequent to purchase which have not been authorized by tekmar; or if the Product was not installed in compliance with tekmar's instructions and/or the local codes and ordinances; or if due to defective installation of the Product; or if the Product was not used in compliance with tekmar's instructions.

THIS WARRANTY IS IN LIEU OF ALL OTHER WARRANTIES, EXPRESS OR IMPLIED, WHICH THE GOVERNING LAW ALLOWS PARTIES TO CONTRACTUALLY EXCLUDE, INCLUDING, WITHOUT LIMITATION, IMPLIED WARRANTIES OF MERCHANTABILITY AND FITNESS FOR A PARTICULAR PURPOSE, DURABILITY OR DESCRIPTION OF THE PRODUCT, ITS NON-INFRINGEMENT OF ANY RELEVANT PATENTS OR TRADEMARKS, AND ITS COMPLIANCE WITH OR NON-VIOLATION OF ANY APPLICABLE ENVIRONMENTAL, HEALTH OR SAFETY LEGISLATION; THE TERM OF ANY OTHER WARRANTY NOT HEREBY CONTRACTUALLY EXCLUDED IS LIMITED SUCH THAT IT SHALL NOT EXTEND BEYOND TWENTY-FOUR (24) MONTHS FROM THE PRODUCTION DATE, TO THE EXTENT THAT SUCH LIMITATION IS ALLOWED BY THE GOVERNING LAW.

Product Warranty Return Procedure All Products that are believed to have defects in workmanship or materials must be returned, together with a written description of the defect, to the tekmar Representative assigned to the territory in which such Product is located. If tekmar receives an inquiry from someone other than a tekmar Representative, including an inquiry from Purchaser (if not a tekmar Representative) or Purchaser's customers, regarding a potential warranty claim, tekmar's sole obligation shall be to provide the address and other contact information regarding the appropriate Representative.



tekmar Control Systems Ltd., Canada
tekmar Control Systems, Inc., U.S.A.
**Head Office: 5100 Silver Star Road
Vernon, B.C. Canada V1B 3K4
(250) 545-7749 Fax. (250) 545-0650
Web Site: www.tekmarcontrols.com**

