

The tekmar Steam Control 279 can operate a single on-off steam boiler or an on-off steam valve using outdoor reset. The control determines the on time of the boiler or valve based on the measured outdoor temperature and settings entered by the installer. A large LCD displays the current status and operating temperatures.

Additional functions include:

- CSA approved for use in USA and Canada
- Outdoor Reset
- Manual Override
- Includes Outdoor Sensor
- Includes Condensate Sensor
- Large LCD Display
- Optional Indoor Sensors
- DHW Tankless Coil Operation
- Warm Weather Shut Down
- Built-in Programmable Timer
- 24 Hour, 5-1-1, 7 Day Schedule
- Two Alert Level Relays

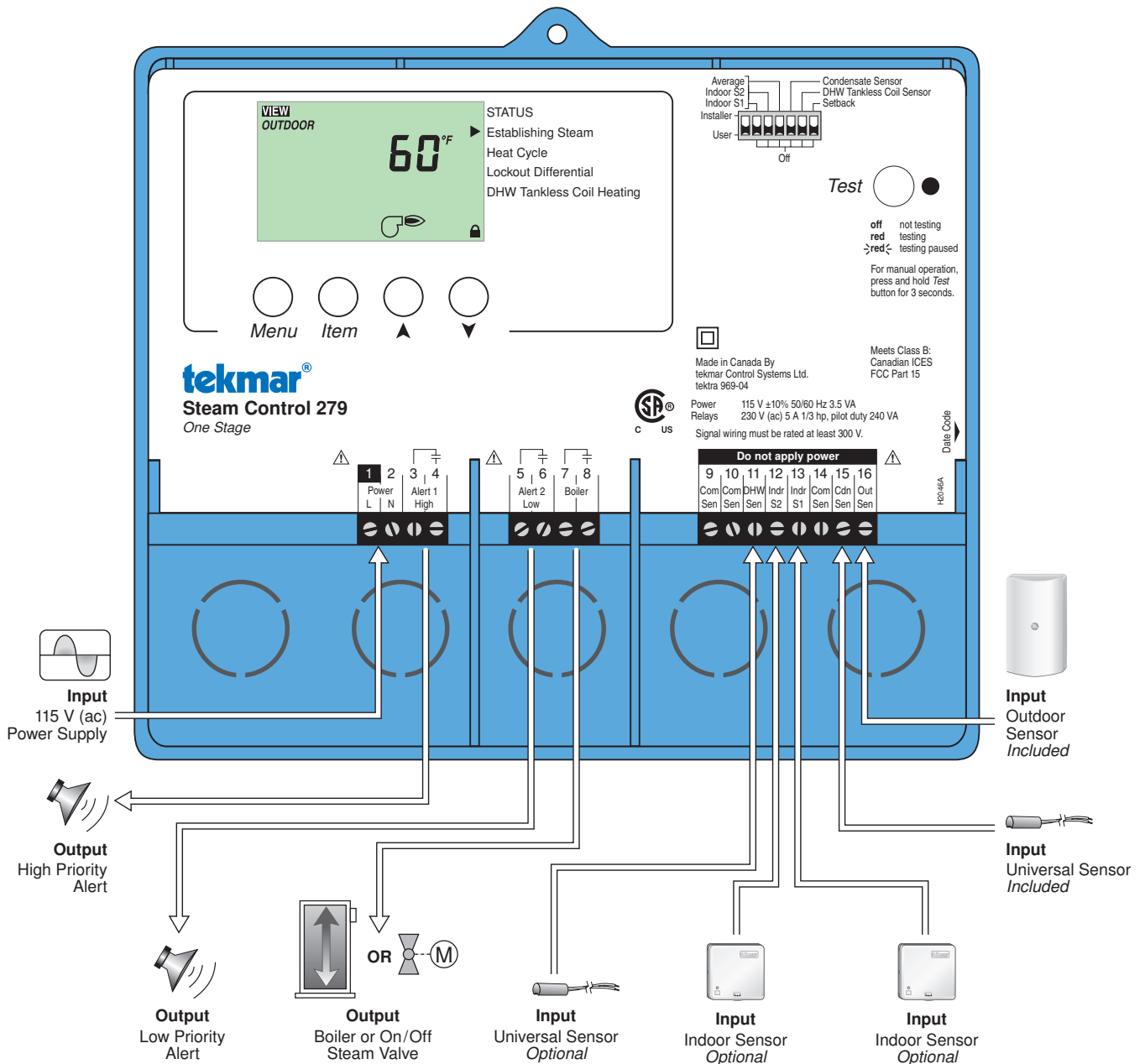

How to Use the Data Brochure

This brochure is organized into four main sections. They are: 1) Sequence of Operation, 2) Installation, 3) Control Settings, and 4) Testing and Troubleshooting. The Sequence of Operation section has fourteen sub-sections. We recommend reading 'Section A: General' of the Sequence of Operation, as this contains important information on the overall operation of the control. Then read the sub sections that apply to your installation.

The Control Settings section (starting at Switch Settings) of this brochure describes the various items that are adjusted and displayed by the control. The control functions of each adjustable item are described in the Sequence of Operation.

Table of Contents

User Interface.....	2	Alert Relay Operation	9
Display and Symbol Description.....	3	Domestic Hot Water Tankless Coil	10
Definitions.....	4	Installation	10
Sequence of Operation.....	4	Cleaning the Control.....	14
General.....	4	Switch Settings.....	15
Establishing Steam.....	4	Display Menus.....	16
Heating Cycle	6	View Menu.....	16
Lockout Differential.....	7	Adjust Menu.....	17
Optional Indoor Sensors.....	8	Time Menu.....	19
Built-in Timer	8	Schedule Menu.....	20
Programmable Schedule	8	Testing the Control.....	20
Warm Weather Shut Down	8	Troubleshooting	21
Optimum Start	9	Error Messages	22
Boost	9	Technical Data.....	24
Limited Occupied.....	9	Limited Warranty	24

User Interface

The control uses a Liquid Crystal Display (LCD) as the method of supplying information. Use the LCD in order to setup and monitor the operation of the system. The control has four push buttons (Menu, Item, ▲, ▼) for selecting and adjusting settings. As the control is programmed, record the settings in the ADJUST Menu table which is found in the second half of this brochure.

Menu

All of the items displayed by the control are organized into four menus: View, Adjust, Time, and Schedule. These menus are listed on the top of the display (Menu Field). To select a menu, use the Menu button. By pressing and releasing the Menu button, the display will advance to the next available menu. Once a menu is selected, there will be a group of items that can be viewed within the menu.

Note: The TIME and SCHEDULE menus are not available when Setback is turned off.

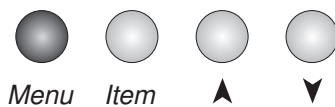

Item

The abbreviated name of the selected item will be displayed in the item field of the display. To view the next available item, press and release the Item button. Once you have reached the last available item in a menu, pressing and releasing the Item button will return the display to the first item in the selected menu.

The items can be quickly scrolled through by holding the Item button and then pressing the ▼ button. To rapidly scroll through the items in the reverse order, hold the Item button and press the ▲ button.

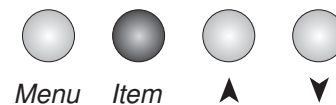

Adjust

To make an adjustment to a setting in the control, begin by selecting the appropriate menu using the Menu button. Then select the desired item using the Item button. Finally, use the ▲ and/or ▼ button to make the adjustment.

Additional information can be gained by observing the Status field of the LCD. The status field will indicate which of the control's outputs are currently active. Most symbols in the status field are only visible when the VIEW Menu is selected.

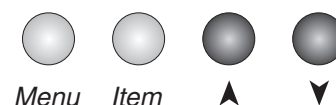

Display

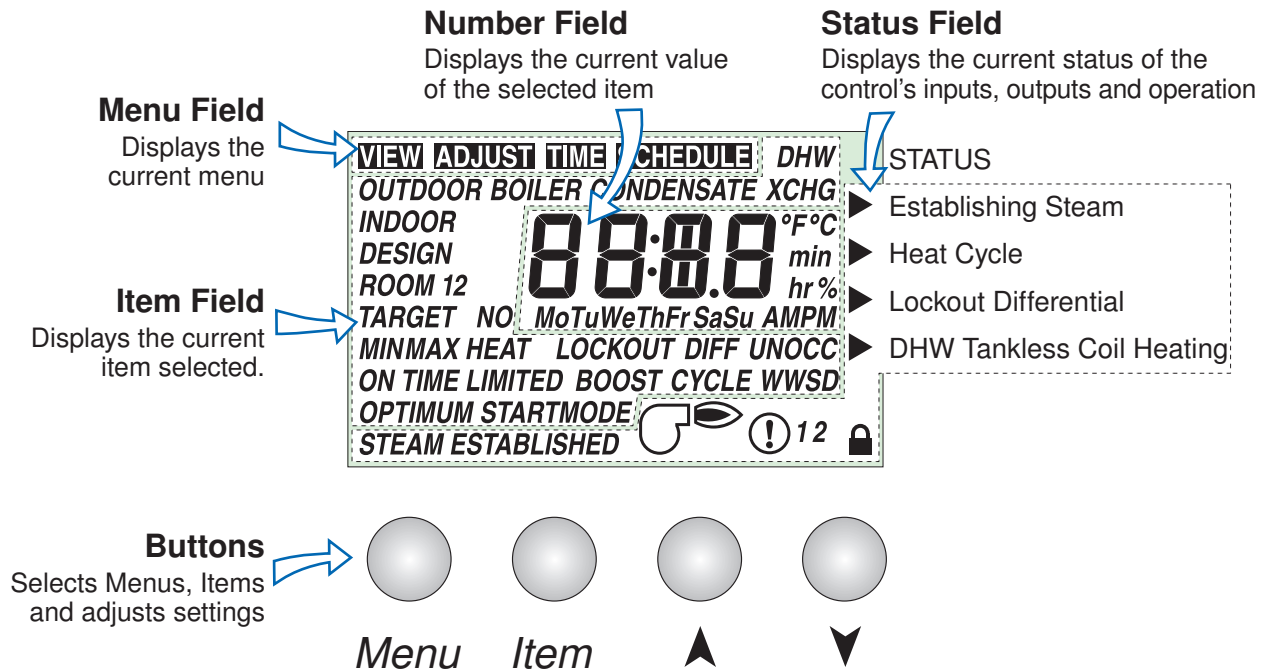

Symbol Description

	POINTER Displays the control operation as indicated by the text.		USER ACCESS LEVEL Displays when the Installer/User Switch Setting is set to the User access level.
°F°C	°F, °C Units of measurement.	STEAM ESTABLISHED	STEAM ESTABLISHED Displays once the condensate sensor reaches a temperature sufficient for steam to reach the furthest radiator.
OCC	OCCUPIED SCHEDULE Displays when the control is in the Occupied event period.	BOOST	BOOST Displays while the boost feature extends the boiler on time to allow recovery after night setback.
UNOCC	UNOCCUPIED SCHEDULE Displays when the control is in the Unoccupied event period.	OPTIMUM START	OPTIMUM START Displays while the Optimum Start feature extends the boiler on time to allow recovery after night setback.
	BURNER Displays when the boiler contact is turned on.	WWSD	WWSD Displays while the control is in Warm Weather Shut Down.
	WARNING 1 2 Displays when an error exists or when a limit has been reached. A 1 indicates a high level alert, a 2 indicates a low level alert.		

Definitions

The following defined terms and symbols are used throughout this manual to bring attention to the presence of hazards of various risk levels, or to important information concerning the life of the product.

 Caution: Refer to accompanying documents.

Sequence of Operation

General

Section A

Powering up the control

When the control is powered on, all segments in the LCD are turned on for 2 seconds. Next, the control displays the control type number in the LCD for 2 seconds. Next, the software version is displayed for 2 seconds. Last, the control enters into the normal operating mode.

Boiler Contact Operation

In single on-off steam boiler applications, the control uses the boiler contact to connect to the thermostat terminals (T-T) on the boiler. The pressure control and all other safety devices and circuits must continue to be wired in series to the burner circuit. The boiler contact on the control is used to turn on or off the steam boiler burner.

In steam valve applications, the boiler contact on the control is used to power the valve motor to open the valve. When power is removed, the valve must close.

Status

The control has a status field on the right hand side of the control. A pointer is shown in the status field once the boiler contact is turned on. The pointer indicates at which point of the steam heating system cycle the control is currently operating at.

The steps are as follows:

- Establishing Steam
- Heat Cycle
- Lockout Differential
- DHW Tankless Coil Heating

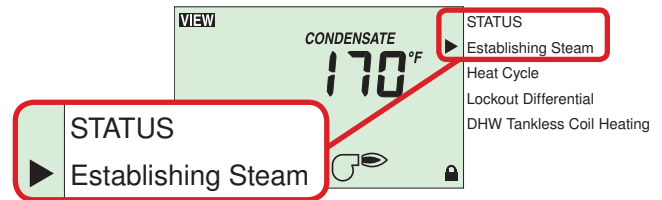

Each of these steps are described in detail in the following sections.

Establishing Steam

Section B

In steam heating systems, there is a time delay between when the steam boiler or steam valve is turned on and when the steam finally reaches the furthest radiator in the system. It is important for the control to determine how long this time delay is in order to ensure proper heating in all rooms. When heat is required, the control activates the boiler relay but does not consider the heating cycle to start until steam has been established at the furthest radiator. While the control is waiting to establish steam, the Status field will have a pointer indicating Establishing Steam.

The control can use one of two methods to determine the time to establish steam.

Condensate Return Sensor

The Universal Sensor 071 included with the control can be used to measure the temperature of the condensate return pipe. In a one pipe system, it is recommended to install the sensor on the bottom of the pipe just before it enters the last radiator. In a two pipe system, it is recommended to install the Condensate Sensor on the bottom of the condensate return pipe of the radiator furthest from the boiler. In cases where access to the furthest radiator is not possible, an alternative is to locate the sensor on the bottom of the condensate return pipe in the mechanical room. Once the condensate sensor is installed, ensure the Condensate Sensor/Off Switch Setting to Condensate Sensor. The measured condensate return temperature reading is visible in the View menu.

The Adjust menu includes a Steam Established setting that delays the start of the heating cycle until the condensate sensor has reached a set temperature.

One method to set the Steam Established setting requires two people with two-way radios. One person is at the control location; the other person is at the furthest radiator

location. The steam system can be manually started using the Max Heat feature. Once the furthest radiator starts to get steam, exit the Max Heat feature and view the Condensate temperature in the View menu. The measured condensate return temperature can be entered as the Steam Established setting.

One Pipe System:

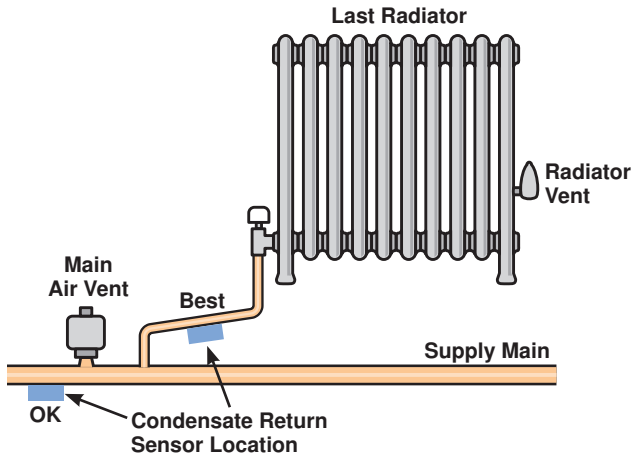

Two Pipe System:

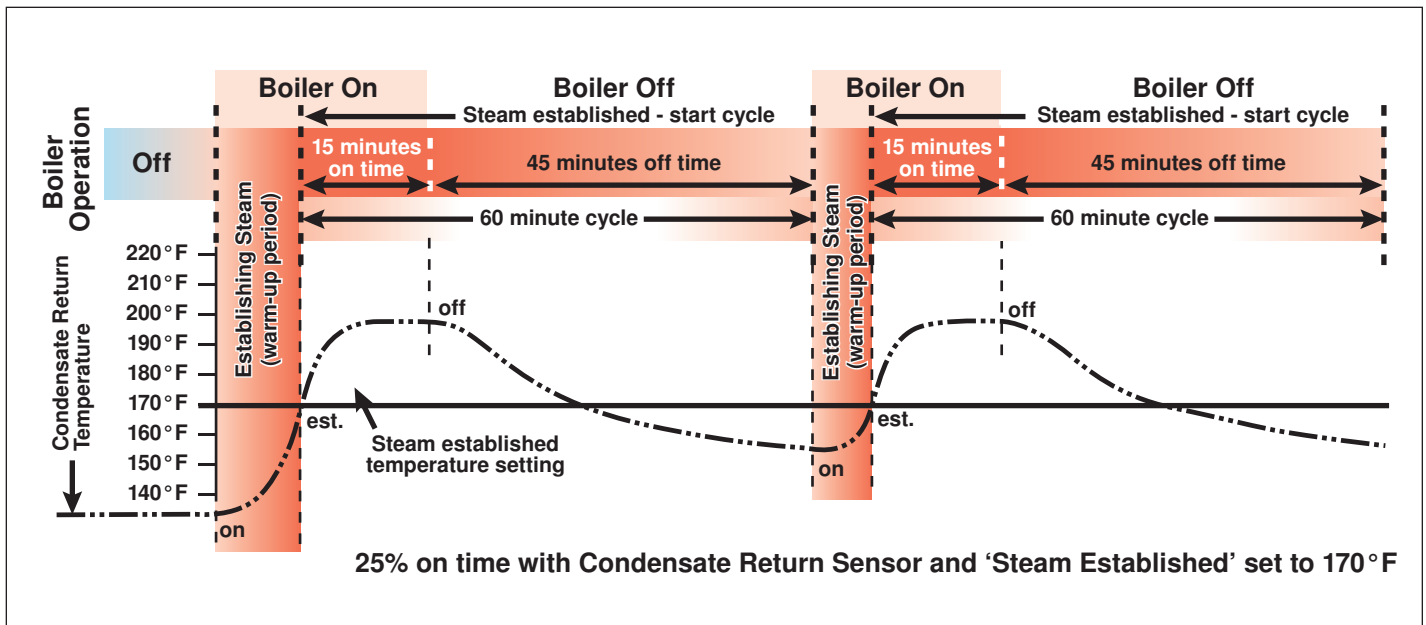
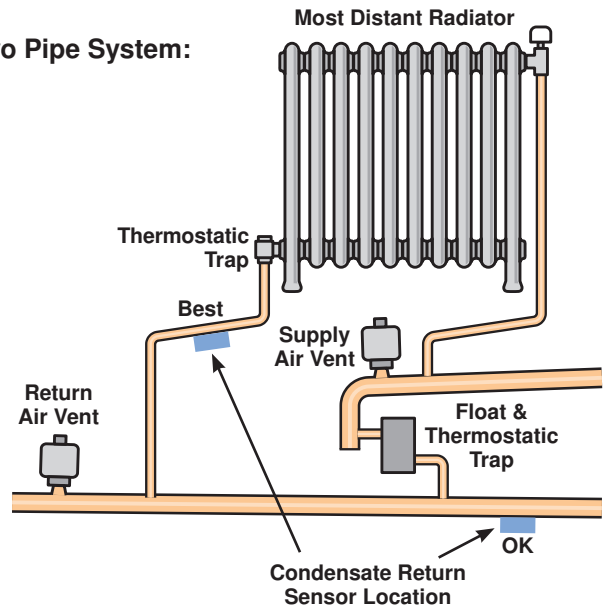

Minimum On Time

In cases where a condensate return sensor cannot be installed, a Minimum On Time can be set to account for the establishing steam time period. Setting a Minimum On Time for a steam system can be problematic because a system takes more time to reach operating temperature from a cold start than when it is hot from a previous cycle.

To set the Minimum On Time, manually start the steam system using the Max Heat feature and at the same time, start a stopwatch timer. Measure the amount of time required for steam to reach the furthest radiator. Then, exit the Max Heat feature and enter the recorded time as the Minimum On Time setting.

Outdoor reset is a method of operating a heating system based on the fact that the rate at which a building loses heat to the outdoor environment is mostly dependent on the surrounding outdoor air temperature. As the outdoor temperature gets colder, the heat loss of the building increases at a proportional rate. This relationship between heat loss and colder outdoor temperatures is called a heating curve.

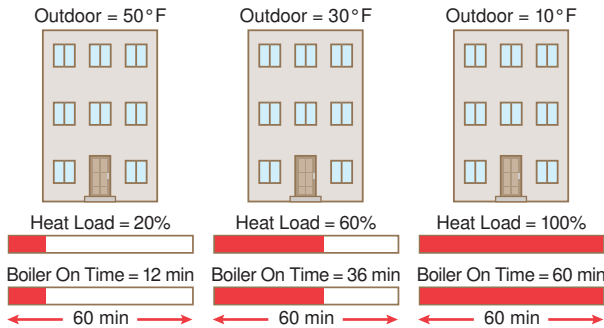

In order to calibrate the control to the heat loss rate of a particular building, the installer is required to enter the following heating curve settings:

Indoor Design

The Indoor Design is the starting point of the heating curve. When the measured outdoor air temperature matches the Indoor Design setting, the control calculates a 0% on time is required for heating the building. The factory default is to start the heating curve at 70°F (21°C).

Outdoor Design

The Outdoor Design is the end point of the heating curve. When the measured outdoor air temperature matches the Outdoor Design setting, the control calculates the boiler on time to be at the Boiler Design % setting. The Outdoor Design should be set to the average coldest annual temperature recorded in the building area.

Boiler Design %

The Boiler Design % is the percent output capacity of the boiler or steam system required to heat the building when the measured outdoor air temperature matches the Outdoor Design setting. The factory default is 100%. If the building envelope has been upgraded to improve the building insulation, the existing steam boiler or steam system may be oversized for the building. In these cases, the Boiler Design % can be reduced to fine tune the heating curve.

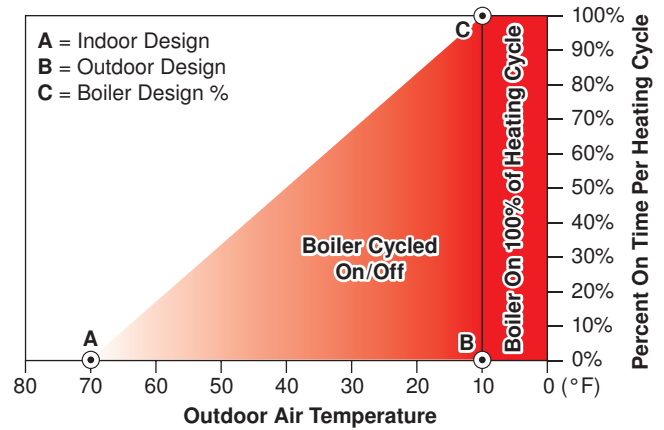

Room (Occupied and Unoccupied)

The Room setting is the desired temperature of the building. When a setback schedule is selected, there is a Room Occupied temperature setting and a Room Unoccupied temperature setting. When the setback schedule is turned off, only the Room setting is available.

When an indoor sensor(s) is not connected to the control, the Room setting operates as a parallel shift of the heating curve. This allows fine tuning of the heating system. If the Room setting is set above the Indoor Design setting, the entire heating curve is shifted higher, resulting in longer percent on times being calculated. Similarly, if the Room setting is set below the Indoor Design setting, the entire heating curve is shifted lower, resulting in shorter percent on times being calculated.

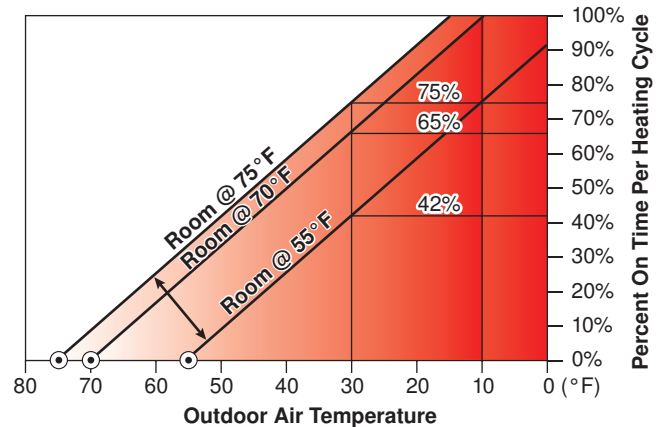

When an indoor sensor(s) is connected to the control, the Room setting becomes a Room Target temperature. The control measures the current air temperature in the room using the indoor sensors. The control then automatically shifts the heating curve so that the measured room temperature reaches the Room Target temperature.

The Adjust menu includes a setting called Cycle that determines how often the heating system will run. During each heating cycle the boiler is turned on once, and the boiler is turned off once. Each building has a natural heat up and a cool off rate. This is determined by many factors such as the size and length of runs in the steam heating system, the size and mass of the radiators, and the heat loss of the building. The factory default is 60 minutes. When using optional Indoor Sensors, an automatic setting is available that allows the control to learn the natural temperature swing of the building. If the optional Indoor Sensors are not used, then the only method of adjustment is trial and error by the installer.

The control is designed to operate on/off steam boilers or steam valves. These systems can only produce heat at a fixed rate (on = 100%, off = 0%). In order to match the heat loss of the building, the steam heating system must be cycled on and off. To determine the boiler on time, the control uses the percent on time required by the heating curve and multiplies this by the heating cycle time. While operating in the heating cycle, the Status field will have a pointer indicating Heat Cycle.

Example: When the outdoor temperature is 32°F (0°C), the heating curve may determine a 50% on time is required. If the heating cycle is 60 minutes, then the boiler on time is: Boiler On Time Per Heating Cycle = 0.5 x 60 minutes = 30 minutes.

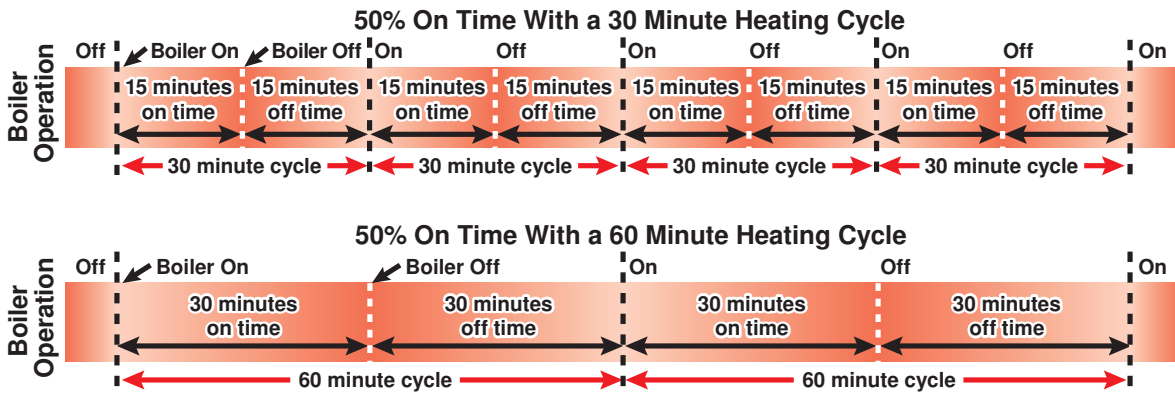

Lockout Differential

Section E

The Adjust menu includes a setting called Lockout Differential. When a condensate return sensor is present, a lockout differential can be set to ensure that any remaining steam in the system condenses and the condensate has time to return to the boiler. This increases the efficiency of the system by removing the latent heat of the steam remaining after the burner is shut down, and lengthening the cycle so that remaining heat is allowed to radiate into the building.

the heating system for the next cycle. During the lockout period, the heating system is held off, and the Status field will have a pointer indicating Lockout Differential. The factory default is a 25°F lockout differential.

The lockout differential is the number of degrees the condensate return sensor temperature must fall below the steam established setting before the control can operate

There is no exact method to set the Lockout Differential for a particular building; it is a process of trial and error. If the building tends to over heat, the lockout differential should be increased to allow the steam system to cool down further before starting the next cycle. If the building tends to under heat, the lockout differential should be decreased to allow the next heating cycle to start sooner.

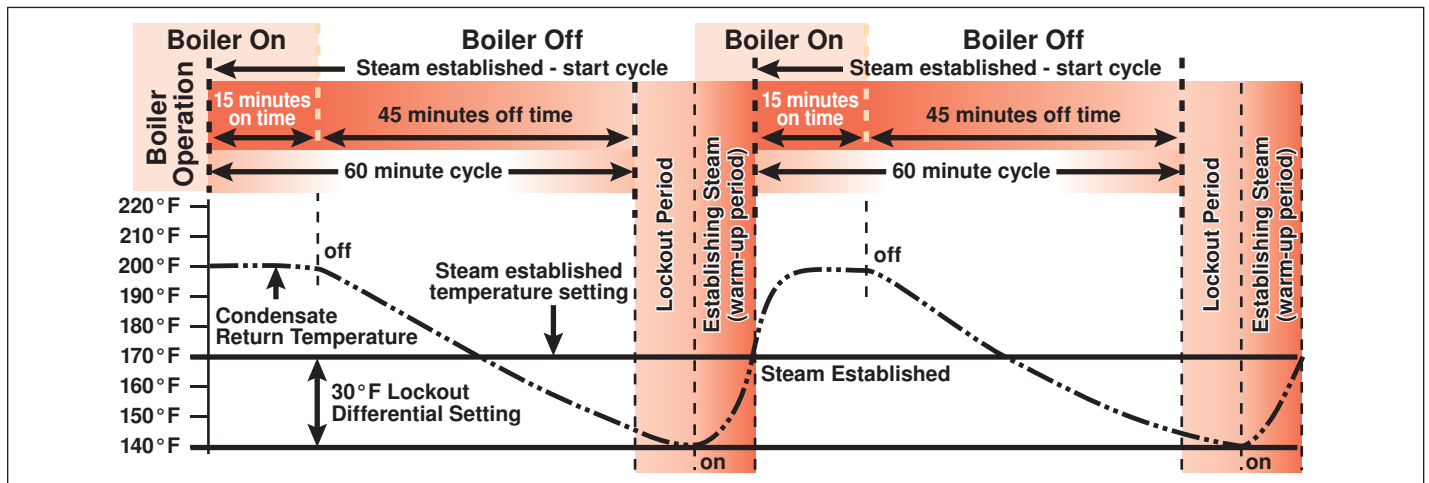

Optional Indoor Sensors

Section F

Multiple indoor sensors can be added to improve the temperature accuracy within the building. Available indoor sensors include the 076, 077 and 084.

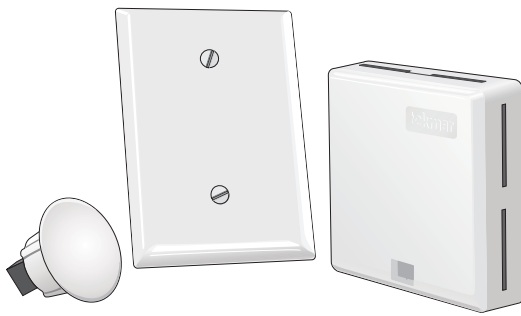

Indoor Sensors 084, 077 and 076

The control allows two indoor sensors to be directly connected to the control. Once an indoor sensor is connected to the indoor sensor S1 input, the Indoor S1/Off switch setting must be set to S1. Likewise, once an indoor sensor is connected to the S2 input, the Indoor S2/Off switch setting must be set to S2.

When indoor sensor 1 is present, the Room 1 temperature is visible in the View menu. Likewise, when indoor sensor 2 is present, the Room 2 temperature is visible in the View menu. Also shown in the View menu is the current Room Target temperature. The room target can be changed by adjusting the Room Occupied or Room Unoccupied setting in the Adjust menu.

Should additional indoor sensors be desired, a square number (4, 9, 16, etc.) of sensors can be wired in series-parallel to a single indoor sensor input.

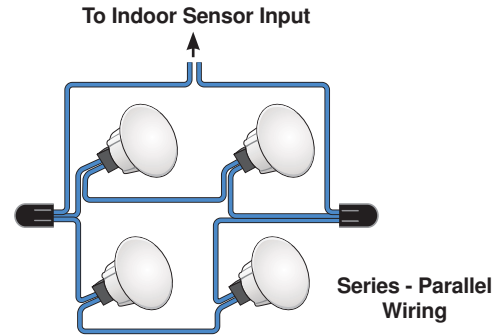

When using two indoor sensor inputs, the control can operate either based upon an average of the two temperature measurements or the control can operate on the lowest of the two temperature measurements.

Temperature Averaging

To operate the steam system based upon the average of the two indoor sensor temperature measurements, set the Average/Off switch setting to Average.

Lowest of Two Temperatures

To operate the steam system based upon the lowest of the two indoor sensor temperature measurements, set the Average/Off switch setting to Off.

Built-in Timer

Section G

The control includes a built-in time clock that is turned on once the Setback/Off switch setting is set to Setback. The time is set in the Time menu. The clock can be set to use either 12 or 24 hour time.

Programmable Schedule

Section H

The control includes a programmable schedule that is turned on once the Setback/Off switch setting is set to Setback. The programmable schedule is set in the Schedule menu. The schedule can be repeated on a 24 hour, 5-1-1, or 7 day schedule. Each schedule allows a time to be set

for the Occupied event and another time to be set for the Unoccupied event. Should it be desired to skip an Occupied or Unoccupied event, set the event time to --:-- , which can be found between 11:50 PM (23:50) and 12:00 AM (0:00).

Warm Weather Shut Down

Section I

The control includes a Warm Weather Shut Down (WWSD) setting in the Adjust menu. When the Setback/Off switch setting is set to Setback, the control includes WWSD Occupied and WWSD Unoccupied settings.

Once the measured outdoor air temperature exceeds the WWSD setting, the steam system is automatically shut down. Once the measured outdoor air temperature falls below the WWSD, the control is able to start a new heating cycle.

Optimum Start

Section J

The control includes an optimum start feature that is available in the Adjust menu when indoor sensors are installed and the Setback/Off switch setting is set to Setback. The optimum start can be set to either on or off.

When a programmable schedule is used to lower the building temperature at night, there is a time delay to increase the building temperature from the Unoccupied to the Occupied temperature. When optimum start is turned on, the control uses the indoor sensor to learn the heat up rate of the building. The control can then accurately predict when the control should increase the heating cycle on time so that the building reaches the Occupied temperature at the scheduled time. Optimum Start is shown on the display while optimum start is in effect.

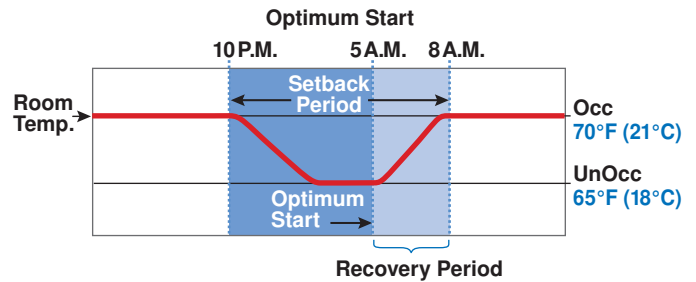

Boost

Section K

The control includes a boost feature that is available in the Adjust menu when indoor sensors are not installed and the Setback/Off switch setting is set to Setback.

When a programmable schedule is used to lower the building temperature at night, there is a time delay to increase the building temperature from the Unoccupied to Occupied temperature. The control shortens the recovery time by determining how long the steam boiler needs to operate at 100% on time of a heating cycle and the boost can continue through multiple heating cycles. The length of the boost is determined by the temperature difference

between Occupied and Unoccupied and the duration of time in setback. The Boost setting allows the installer to set the maximum amount of time that Boost can remain in effect. Boost is shown on the display while boost is in effect.

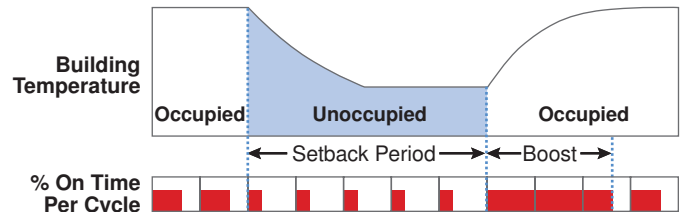

Limited Unoccupied

Section L

The control includes a Limited Unoccupied feature that is available in the Adjust menu. When the Limited Unoccupied is set to on and the heating cycle reaches 85% on time, the control is prevented from going into the Unoccupied mode in order to avoid long recovery times. If the control is already in the Unoccupied mode and the outdoor temperature drops

so that the heating cycle on time exceeds 85%, the control will switch back into the Occupied mode. When the Limited Unoccupied is set to off, the control continues to operate on the regular Occupied/Unoccupied schedule, regardless of the heating cycle on time.

Alert Relay Operation

Section M

The alert relays can be used to connect to security systems, alarm panels or telephone dialers to provide an alert signal should the control have an error message present.

Note: The 279 is not a UL approved alarm panel.

Alert 1 Relay

The Alert 1 Relay closes when the outdoor, condensate, room 1, room 2, or DHW tankless coil sensor has either an open or short circuit.



Alert 2 Relay

The Alert 1 Relay closes when the control has an E01 Memory Error message, or when either Room 1 or Room 2 sensor measures a temperature below 38°F (3.5°C).



The control can replace the mechanical aquastat in the steam boiler that operates a tankless coil domestic hot water system with an optional DHW Tankless Coil Sensor. The sensor is installed into the 1/2" (12 mm) immersion well that measures the temperature of the tankless coil.

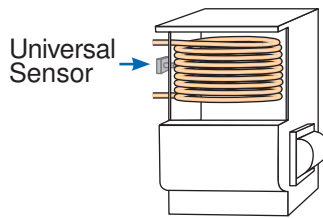

The advantage of using the DHW Tankless Coil feature is that the control can be programmed to operate the tankless coil on a night setback schedule. This can lower fuel usage for domestic hot water heating. The DHW tankless coil operation of the boiler is separate from the steam heating operation and is not affected by the heating system settings.

It is recommended that an anti-scald valve be installed on the domestic hot water system.

Once the sensor is installed, the DHW Tankless Coil Sensor/Off switch setting must be set to DHW Tankless Coil. The DHW Exchange (DHW XCHG) temperature is visible in the View menu and is a measurement of the DHW Tankless Coil Sensor. The DHW Tankless Coil temperature can be set using the DHW XCHG Occupied and the DHW XCHG Unoccupied settings in the Adjust menu. When the steam boiler is turned on for DHW tankless coil heating, the Status field will have a pointer indicating DHW Tankless Coil Heating.

The DHW Exchange Occupied and Unoccupied target temperature is maintained with a fixed differential of 10°F (5.5°C). The differential is half above and half below the target.

Installation

⚠ Caution

Improper installation and operation of this control could result in damage to the equipment and possibly even personal injury or death. It is your responsibility to ensure that this control is safely installed according to all applicable codes and standards. This electronic control is not intended for uses as a primary limit control. Other controls that are

intended and certified as safety limits must be placed into the control circuit. Do not attempt to service the control. Refer to qualified personnel for servicing. Opening voids warranty and could result in damage to the equipment and possibly even personal injury or death.

Step One — Getting Ready

Check the contents of this package. If any of the contents listed are missing or damaged, please contact your wholesaler or tekmar sales representative for assistance.

Type 279 includes:

One Steam Control 279, One Outdoor Sensor 070, One Universal Sensor 071, Data Brochures D279, D070, D001, Application Brochure A279.

Note: Carefully read the details of the Sequence of Operation to ensure the proper control was chosen for the application.

Step Two — Mounting the Base

Remove the control from its base by pressing on the release clip in the wiring chamber and sliding the control away from it. The base is then mounted in accordance with the instructions in the Data Brochure D001.

Step Three — Rough-in Wiring

All electrical wiring terminates in the control base wiring chamber. The base has standard 7/8" (22 mm) knockouts, which accept common wiring hardware and conduit fittings. Before removing the knockouts, check the wiring diagram and select those sections of the chamber with common voltages. Do not allow the wiring to cross between sections as the wires will interfere with safety dividers which should be installed at a later time.

Power must not be applied to any of the wires during the rough-in wiring stage.

- All wires are to be stripped to a length of 3/8" (9 mm) to ensure proper connection to the control.
- Install the Outdoor Sensor 070 according to the installation instructions in the Data Brochure D 070 and run the wiring back to the control.
- Install the Indoor Sensor 076, 077, or 084 according to the installation instruction in the Data Brochure D 076, D 077, or D 084 and run the wiring back to the control.
- Install the Condensate Sensor 071 according to the installation instructions in the Data Brochure D 070 and run the wiring back to the control.
- Install the DHW Tankless Coil Sensor 082 according to the installation instructions in the Data Brochure D 070 and run the wiring back to the control.
- Run wires from any security system, alarm panel, or telephone dialer back to the control.
- Run wires from the 115 V (ac) power to the control. Use a clean power source with a 15 A circuit to ensure proper operation. Multi-strand 16 AWG wire is recommended for all 115 V (ac) wiring due to its superior flexibility and ease of installation into the terminals.

Step Four — Electrical Connections to the Control

General

The installer should test to confirm that no voltage is present at any of the wires. Push the control into the base and slide it down until it snaps firmly into place.

⚠ Powered Input Connections

Terminals 1, 2

115 V (ac) Power

Connect the 115 V (ac) power supply to the Power L and Power N terminals (1 and 2). This connection provides power to the microprocessor and display of the control.

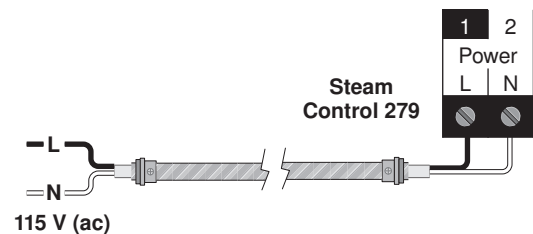

⚠ Output Connections

Terminals 3 - 8

Alert 1

The Alert 1 terminals (3 and 4) are isolated outputs in the control. There is no power available on these terminals from the control. These terminals are to be used as a switch to either make or break a signal to a security system, alarm panel, or telephone dialer. Since this is an isolated contact, it may switch a voltage up to 230 V (ac).

Note: Alert 1 requires a minimum current of 0.1 A in order to keep the contact functioning properly.

Alert 2

The Alert 2 terminals (5 and 6) are isolated outputs in the control. There is no power available on these terminals from the control. These terminals are to be used as a switch to either make or break a signal to a security system, alarm panel, or telephone dialer. Since this is an isolated contact, it may switch a voltage up to 230 V (ac).

Note: Alert 2 requires a minimum current of 0.1 A in order to keep the contact functioning properly.

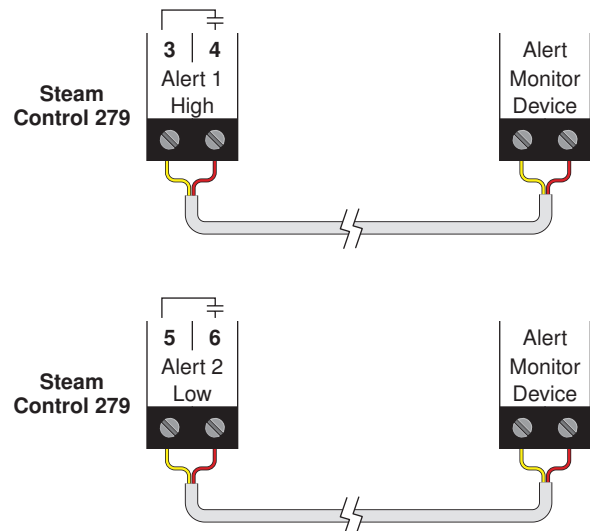

Boiler

The Boiler terminals (7 and 8) are isolated outputs in the control. There is no power available on these terminals from the control. These terminals are to be used as a switch to either make or break the thermostat input on a steam boiler or the power to a steam valve. Since this is an isolated contact, it may switch a voltage between 24 V (ac) and 230 V (ac).

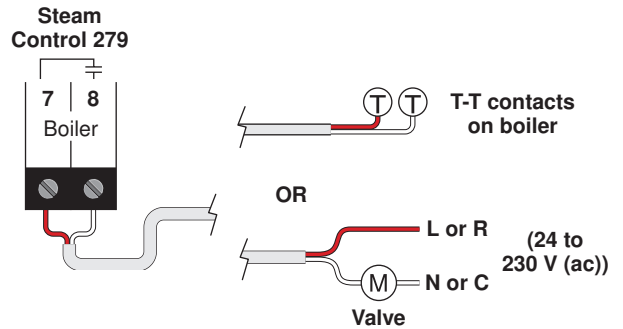

⚠ Sensor and Unpowered Input Connections

Terminals 10 - 16

Do not apply power to these terminals as this will damage the control.

Outdoor Sensor

Connect the two wires from the Outdoor Sensor 070 to the Com Sen and Out Sen terminals (14 and 16). The outdoor sensor is used by the control to measure the outdoor air temperature.

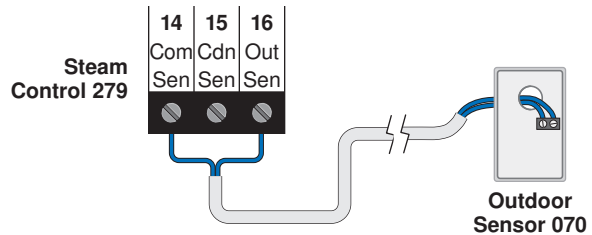

Condensate Sensor

Connect the two wires from the Condensate Sensor 071 to the Com Sen and Cdn Sen terminals (14 and 15). The condensate sensor is used by the control to measure the condensate temperature.

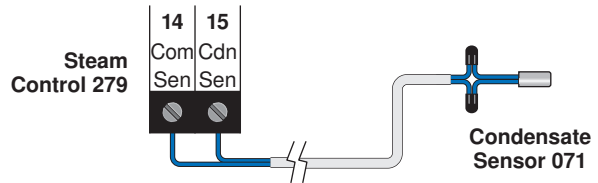

Indoor Sensor S1

Connect the two wires from the Indoor Sensor 076, 077, or 084 to the Com Sen and Indr S1 terminals (10 and 13). The indoor sensor is used by the control to measure the room air temperature.

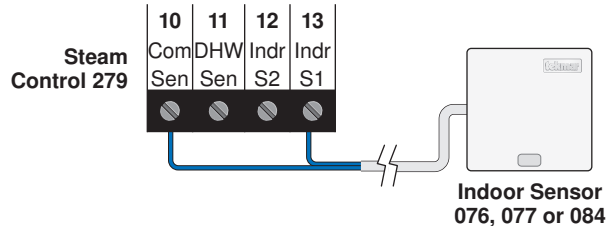

Indoor Sensor S2

Connect the two wires from the Indoor Sensor 076, 077, or 084 to the Com Sen and Indr S2 terminals (10 and 12). The indoor sensor is used by the control to measure the room air temperature.

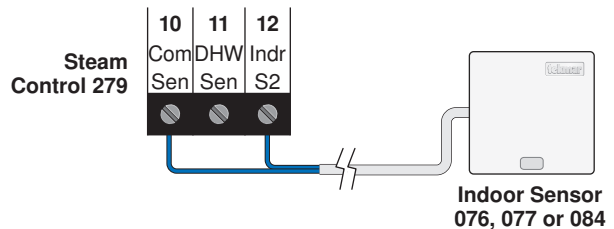

DHW Tankless Coil Sensor

Connect the two wires from the DHW Tankless Coil Sensor 082 to the Com Sen and DHW Sen terminals (9 and 11). The DHW tankless coil sensor is used by the control to measure the tankless coil temperature.

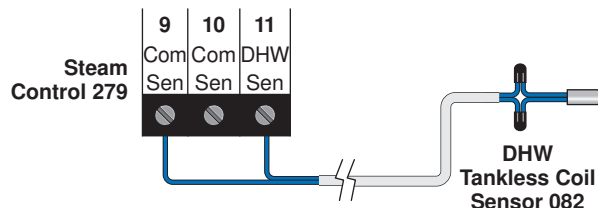

Step Five — Testing the Wiring

General

Each terminal block must be unplugged from its header on the control before power is applied for testing. To remove the terminal block, pull straight down from the control.

The following tests are to be performed using standard testing practices and procedures and should only be carried out by properly trained and experienced persons.

Test the Sensors

In order to test the sensors, the actual temperature at each sensor location must be measured. A good quality digital thermometer with a surface temperature probe is recommended for ease of use and accuracy. Where a digital thermometer is not available, a spare sensor can be strapped alongside the one to be tested and the readings compared. Test the sensors according to the instructions in the Data Brochure D070.

A good quality electrical test meter, capable of reading from at least 0 – 300 V (ac) and at least 0 – 2,000,000 Ohms, is essential to properly test the wiring and sensors.

Test the Power Supply

Make sure exposed wires and bare terminals are not in contact with other wires or grounded surfaces. Turn on the power and measure the voltage between the Power L and Power N terminals (1 and 2) using an AC voltmeter, the reading should be between 103.5 and 126.5 V (ac).

Test the Outputs

Alert 1

If a security system, alarm panel, or telephone dialer is connected to the Alert 1 terminals (3 and 4), install a jumper wire between the terminals. The security system, alarm panel, or telephone dialer should respond. If the security system, alarm panel, or telephone dialer does not respond properly, refer to any installation or troubleshooting information supplied with the security system, alarm panel, or telephone dialer equipment. If the security system, alarm panel, or telephone dialer operates properly, then remove the jumper wire.

Alert 2

If a security system, alarm panel, or telephone dialer is connected to the Alert 2 terminals (5 and 6), install a jumper wire between the terminals. The security system, alarm panel, or telephone dialer should respond. If the security system, alarm panel, or telephone dialer does not respond properly, refer to any installation or troubleshooting information supplied with the security system, alarm panel, or telephone dialer equipment. If the security system, alarm panel, or telephone dialer operates properly, remove the jumper wire.

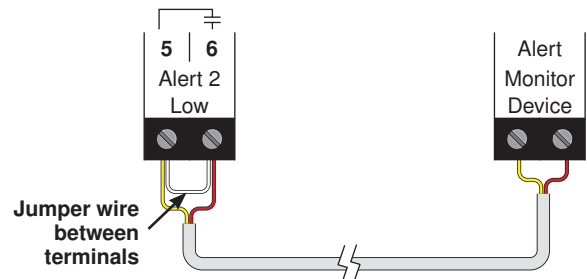
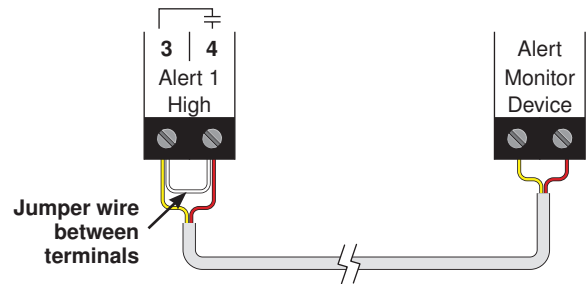
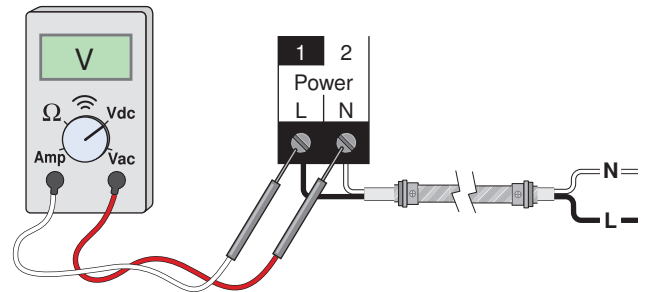
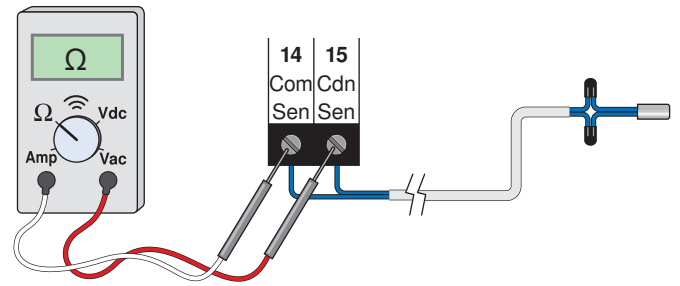

Boiler

If a steam boiler or steam valve is connected to the Boiler terminals (7 and 8), make sure power to the boiler circuit is off and install a jumper between the terminals. When the circuit is powered up, the boiler should fire or the steam valve should open. If the boiler or steam valve does not turn on, refer to any installation or troubleshooting information supplied with the boiler or steam valve. If the boiler or steam valve operates properly, disconnect the power and remove the jumper.

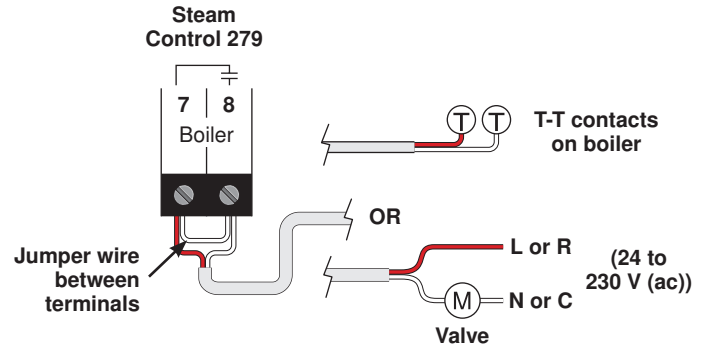

Connecting the Control

Make sure all power to the devices and terminal blocks is off, and remove any remaining jumpers from the terminals.

Reconnect the terminal blocks to the control by carefully aligning them with their respective headers on the control, and then pushing the terminal blocks into the headers. The terminal blocks should snap firmly into place.

Install the supplied safety dividers between the unpowered sensor inputs and the powered or 115 V (ac) wiring chambers.

Apply power to the control. The operation of the control on power up is described in the Sequence of Operation section of the brochure.

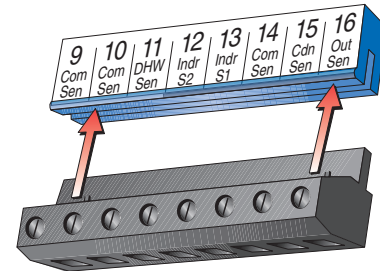

Cleaning the Control

The control's exterior can be cleaned using a damp cloth. Moisten the cloth with water and wring out prior to wiping the control. Do not use solvents or cleaning solutions.

Switch Settings

GENERAL

The switch settings on the control are very important and should be set to the appropriate settings prior to making any adjustments to the control through the User Interface. The switch settings change the items that are available to be viewed and/or adjusted in the User Interface.

If a switch setting is changed while the control is powered up, the control responds to the change in setting by returning the display to the VIEW menu.

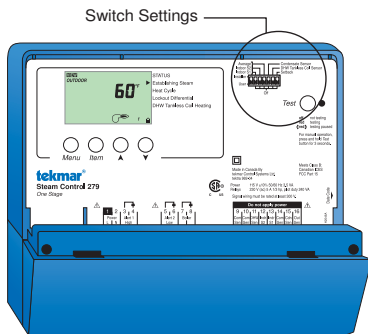

Installer/User

The Installer/User switch selects the access level of the control. In the User access level, a limited number of items may be viewed and adjusted. In the Installer access level, all items may be viewed and adjusted.

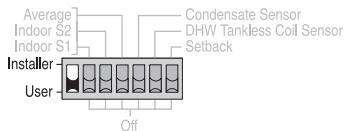

Indoor S1/Off

The Indoor S1/Off switch selects whether or not an indoor sensor is connected to the indoor sensor S1 terminals (10 and 13).

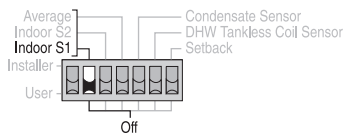

Indoor S2/Off

The Indoor S2/Off switch selects whether or not an indoor sensor is connected to the indoor sensor S2 terminals (10 and 12).

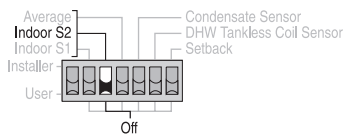

Average/Off

The Average/Off switch only applies when both indoor sensor S1 and S2 are on and both indoor sensors are present.

If the switch is set to Average, the control operates the steam system based on the average of the two indoor sensor temperature readings. If the switch is set to Off, the control operates the steam system based on the coldest of the two indoor sensor temperature measurements.

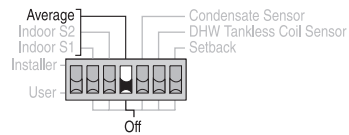

Condensate Sensor/Off

The Condensate Sensor/Off switch selects whether or not a condensate sensor is connected to the Condensate Sensor terminals (14 and 15).

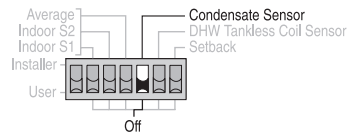

DHW Tankless Coil Sensor/Off

The DHW Tankless Coil Sensor/Off switch selects whether or not a DHW tankless coil sensor is connected to the DHW Sensor terminals (9 and 11).

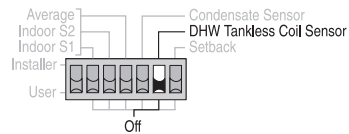

Setback/Off

The Setback/Off switch selects whether or not the internal setback timer and schedule is to be used. If the switch is set to Setback, the time must be set and the setback schedule must be entered in order to provide setback events.

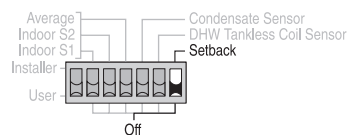

Display Menus

View Menu (1 of 1)

Menu



Item



The View menu items display the current operating temperatures and status information of the system.

VIEW MENU

Item Field	Range	Access	Description
<p>VIEW OUTDOOR</p> <p>31^{°F} occ</p> <p>🔒</p>	-76 to 149°F (-60.0 to 65.0°C)	User	<p>OUTDOOR SECTION C</p> <p>Current outdoor air temperature as measured by the outdoor sensor.</p>
<p>VIEW ROOM 1</p> <p>70^{°F} occ</p> <p>🔒</p>	-31 to 266°F (-35.0 to 130.0°C)	User	<p>ROOM 1 SECTION F</p> <p>Current room air temperature as measured by indoor sensor 1.</p> <p>Available when:</p> <ul style="list-style-type: none"> Indoor Sensor S1/Off switch setting is set to S1.
<p>VIEW ROOM 2</p> <p>76^{°F} occ</p> <p>🔒</p>	-49 to 203°F (-45.0 to 95.0°C)	User	<p>ROOM 2 SECTION F</p> <p>Current room air temperature as measured by indoor sensor 2.</p> <p>Available when:</p> <ul style="list-style-type: none"> Indoor Sensor S2/Off switch setting is set to S2.
<p>VIEW ROOM TARGET</p> <p>70^{°F} occ</p>	35 to 100°F (1.5 to 38.0°C)	Installer	<p>ROOM TARGET SECTION F</p> <p>Desired temperature of the building.</p> <p>Available when:</p> <p>Indoor Sensor S1/Off switch setting is set to S1. OR Indoor Sensor S2/Off switch setting is set to S2.</p>
<p>VIEW CONDENSATE</p> <p>155^{°F} occ</p>	-31 to 266°F (-35.0 to 130.0°C)	Installer	<p>CONDENSATE SECTION B</p> <p>Current condensate return temperature as measured by the condensate sensor.</p> <p>Available when:</p> <ul style="list-style-type: none"> Condensate/Off switch setting is set to Condensate.
<p>VIEW DHW XCHG</p> <p>136^{°F} occ</p>	-31 to 266°F (-35.0 to 130.0°C)	Installer	<p>DHW EXCHANGE SECTION N</p> <p>Current DHW tankless coil temperature as measured by the tankless coil sensor.</p> <p>Available when:</p> <ul style="list-style-type: none"> DHW Tankless Coil Sensor/Off switch settings is set to DHW Tankless Coil Sensor.
<p>VIEW BOILER</p> <p>0 %</p>	0 to 100 %	Installer	<p>BOILER % SECTION C</p> <p>The calculated percentage on time of a heating cycle that the steam boiler will operate.</p>
<p>VIEW BOILER</p> <p>000 hr UNOCC</p> <p>🔒</p>	0 to 9999 hours	User	<p>BOILER HOURS</p> <p>The total running time that the boiler contact was closed since this item was last cleared. Press Up and Down buttons together to zero the boiler hours.</p>

After the last item, the control returns to the first item in the menu.

Adjust Menu (1 of 3)

Menu



Item

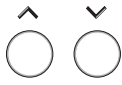

The Adjust Menu items are the programmable settings used to operate the mechanical equipment.

ADJUST MENU

Item Field	Range	Access	Description	Actual Setting
<p>ADJUST</p> <p>ROOM 70^{°F} occ</p>	<p>35 to 100°F (1.5 to 38.0°C) Default = 70°F (21.0°C)</p>	User	<p>ROOM OCCUPIED SECTION F</p> <p>Select the desired room temperature of the building during the occupied period.</p>	
<p>ADJUST</p> <p>ROOM 65^{°F} UNOCC</p>	<p>35 to 100°F (1.5 to 38.0°C) Default = 65°F (18.5°C)</p>	User	<p>ROOM UNOCCUPIED SECTION F</p> <p>Select the desired room temperature of the building during the unoccupied period.</p> <p>Available when:</p> <ul style="list-style-type: none"> Setback/Off switch setting is set to Setback. 	
<p>ADJUST</p> <p>OFF</p> <p>OPTIMUM START</p>	<p>OFF, On Default = OFF</p>	Installer	<p>OPTIMUM START SECTION J</p> <p>Select whether or not optimum start should be used to recover from Unoccupied to Occupied temperature.</p> <p>Available when:</p> <ul style="list-style-type: none"> Setback/Off switch setting is set to Setback. <p>AND</p> <ul style="list-style-type: none"> Indoor Sensor S1/Off switch setting is set to S1 or Indoor Sensor S2/Off switch setting is set to S2. 	
<p>ADJUST</p> <p>OFF</p> <p>BOOST</p>	<p>OFF, 0:20 to 8:00 hr Default = OFF</p>	Installer	<p>BOOST SECTION K</p> <p>Select the maximum amount of time that boost can be in effect to recover from Unoccupied to Occupied temperature.</p> <p>Available when:</p> <ul style="list-style-type: none"> Setback/Off switch setting is set to Setback. <p>AND</p> <ul style="list-style-type: none"> Indoor Sensor S1/Off switch setting is set to Off and Indoor Sensor S2/Off switch setting is set to Off. 	
<p>ADJUST</p> <p>OFF</p> <p>LIMITED UNOCC</p>	<p>OFF, On Default = OFF</p>	Installer	<p>LIMITED UNOCCUPIED SECTION L</p> <p>Select if the night setback should be limited once the boiler % reaches 85% on time.</p> <p>Available when:</p> <ul style="list-style-type: none"> Setback/Off switch setting is set to Setback. 	
<p>ADJUST</p> <p>OUTDOOR DESIGN 10^{°F}</p>	<p>-60 to 30°F (-51.0 to -1.0°C) Default = 10°F (-12.0°C)</p>	Installer	<p>OUTDOOR DESIGN SECTION C</p> <p>Select the design outdoor air temperature used in the heat loss calculations for the heating system. Typically set to the temperature of the coldest day of the year.</p>	
<p>ADJUST</p> <p>BOILER DESIGN 100 %</p>	<p>5 to 100% Default = 100%</p>	User	<p>BOILER DESIGN PERCENT SECTION C</p> <p>Select the boiler percent output when the outdoor temperature reaches the outdoor design setting. Reduce the percentage if the boiler is oversized for the building.</p>	

Continued on next page.

Adjust Menu (2 of 3)

ADJUST MENU

Item Field	Range	Access	Description	Actual Setting
<p>ADJUST</p> <p>INDOOR DESIGN</p> <p>70^{°F}</p>	<p>35 to 100°F (1.5 to 38.0°C)</p> <p>Default = 70°F (21.0°C)</p>	Installer	<p>INDOOR DESIGN SECTION C</p> <p>Select the design indoor air temperature used in the heat loss calculations. Typically set to the desired indoor temperature.</p>	
<p>ADJUST</p> <p>60^{min}</p> <p>CYCLE</p>	<p>Auto, 20 to 100 min</p> <p>Default = 60 min</p>	Installer	<p>CYCLE SECTION D</p> <p>Select the length of the heating cycle in minutes. Auto setting is only available when indoor sensors are present.</p>	
<p>ADJUST</p> <p>180^{°F}</p> <p>STEAM ESTABLISHED</p>	<p>100 to 220°F (38.0 to 104.5°C)</p> <p>Default = 180°F (82.0°C)</p>	Installer	<p>STEAM ESTABLISHED SECTION B</p> <p>Select the condensate return temperature at which steam is established at the furthest radiator.</p> <p>Available when:</p> <ul style="list-style-type: none"> • Condensate Sensor/Off switch setting is set to Condensate Sensor. 	
<p>ADJUST</p> <p>25^{°F}</p> <p>LOCKOUT DIFF</p>	<p>OFF, 5 to 100°F (OFF, 3.0 to 38.0°C)</p> <p>Default = 25°F (14.0°C)</p>	Installer	<p>LOCKOUT DIFFERENTIAL SECTION E</p> <p>Select the number of degrees below the steam established temperature at which to start the next heating cycle.</p> <p>Available when:</p> <ul style="list-style-type: none"> • Condensate Sensor/Off switch setting is set to Condensate Sensor. 	
<p>ADJUST</p> <p>0^{min}</p> <p>MIN ON TIME</p>	<p>0 to 50 min</p> <p>Default = 0 min</p>	Installer	<p>MINIMUM ON TIME SECTION B</p> <p>Select the length of time in minutes to establish steam at the furthest radiator.</p> <p>Available when:</p> <ul style="list-style-type: none"> • Condensate Sensor/Off switch setting is set to Off. 	
<p>ADJUST</p> <p>DHW XCHG</p> <p>160^{°F}</p> <p>occ</p>	<p>140 to 200°F (60.0 to 93.5°C)</p> <p>Default = 160°F (71.0°C)</p>	Installer	<p>DHW EXCHANGE OCCUPIED SECTION N</p> <p>Select the tankless coil temperature required for domestic hot water during the occupied time period.</p> <p>Available when:</p> <ul style="list-style-type: none"> • DHW Tankless Coil Sensor/Off switch setting is set to DHW Tankless Coil Sensor. 	
<p>ADJUST</p> <p>DHW XCHG</p> <p>OFF</p> <p>UNOCC</p>	<p>OFF, 140 to 200°F (OFF, 60.0 to 93.5°C)</p> <p>Default = OFF</p>	Installer	<p>DHW EXCHANGE UNOCCUPIED SECTION N</p> <p>Select the tankless coil temperature required for domestic hot water during the unoccupied time period.</p> <p>Available when:</p> <ul style="list-style-type: none"> • DHW Tankless Coil Sensor/Off switch setting is set to DHW Tankless Coil Sensor. <p>AND</p> <ul style="list-style-type: none"> • Setback/Off switch setting is set to Setback. 	

Continued on next page.

Adjust Menu (3 of 3)

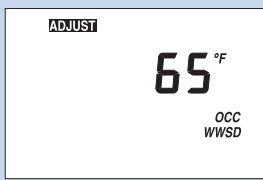
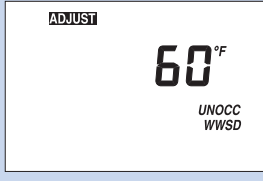
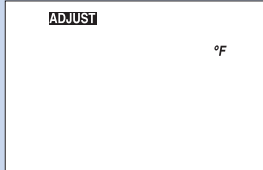
Item Field	Range	Access	Description	Actual Setting
	35 to 100°F (1.5 to 38.0°C) Default = 65°F (18.5°C)	User	WARM WEATHER SHUT DOWN OCCUPIED SECTION I Select the steam system's warm weather shut down temperature during the occupied period. WWSD does not affect DHW Tankless Coil operation.	
	35 to 100°F (1.5 to 38.0°C) Default = 60°F (15.5°C)	User	WARM WEATHER SHUT DOWN UNOCCUPIED SECTION I Select the steam system's warm weather shut down temperature during the unoccupied period. WWSD does not affect DHW Tankless Coil operation. Available when: • Setback/Off switch setting is set to Setback.	
	°F or °C Default = °F	User	TEMPERATURE UNITS Select to display temperature in °F or °C.	

ADJUST MENU

After the last item, the control returns to the first item in the menu.

Time Menu

Note: The Setback / Off switch setting must be in the Setback position in order to have access to the TIME menu.

Setting the Time



Step 1

Press and release the Menu button until the TIME menu is reached.

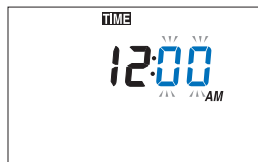

Step 2

Press the Item button. While the minutes are flashing, use the ▲ or ▼ button to set the minutes.



Step 3

Press and release the Item button. While the hours are flashing, use the ▲ or ▼ button to set the hour.



Step 4

Press and release the Item button. While the day is flashing, use the ▲ or ▼ button to set the day.

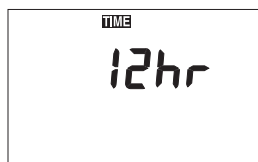

Step 5 (Only available in Installer access level)

Press and release the Item button. Use the ▲ or ▼ button to select between 12 and 24 hour time.

Schedule Menu

Note: The Setback/Off switch setting must be in the Setback position in order to have access to the SCHEDULE menu.

Setting the Schedule

A schedule allows the timer to automatically change between two preset events based on the time of day. The schedule divides the day into Occupied and Unoccupied periods. To set the time of day at which each period is to begin, use the following procedure.

Step 1

Press and release the Menu button until the Schedule menu is displayed.

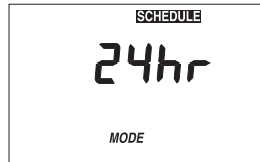

Step 2 (Only available in advanced access level.)

Use the ▲ or ▼ button to select a 24 hour, 5-1-1 day, or a 7 day schedule.

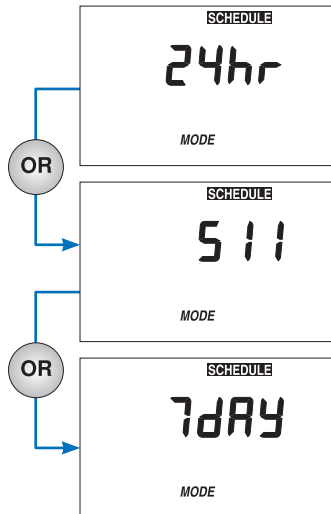

Step 3

Press and release the Item button. Use the ▲ or ▼ button to set the event's beginning time. If the event is not required, select the "-- : --" time. This time is found between 11:50 PM and 12:00 AM. Press the Item button to advance to the next setting.

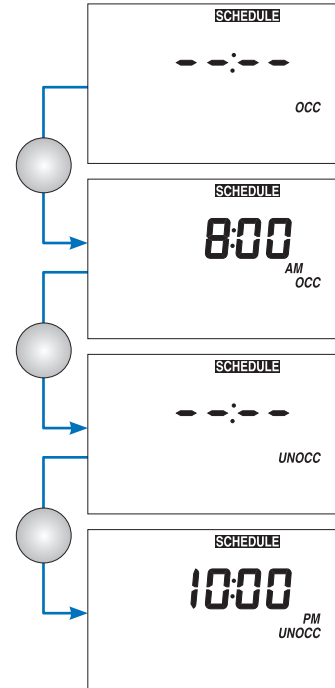

Testing the Control

The control has a built-in test routine that is used to test the main control functions. The control continually monitors the sensors and displays an error message whenever a fault is found. See the following pages for a list of the control's error messages and possible causes. When the Test button is pressed, the Test light is turned on. The individual outputs and relays are tested in the following test sequence.

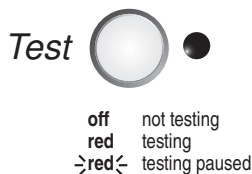

Test Sequence

Each step in the test sequence lasts 10 seconds.

During the test routine, the test sequence may be paused by pressing the Test button. If the Test button is not pressed

again for 5 minutes while the test sequence is paused, the control exits the entire test routine. If the test sequence is paused, the Test button can be pressed again to advance to the next step. This can also be used to rapidly advance through the test sequence. To reach the desired step, repeatedly press and release the Test button until the appropriate device and segment in the display turn on.

Step 1

Turn on the Boiler relay for 10 seconds, then shut off.



Step 2

Turn on the Alert 1 relay for 10 seconds, then shut off.



Step 3

Turn on the Alert 2 relay for 10 seconds, then shut off.



Max Heat

The control has a function called Max Heat. In this mode, the control turns on and operates the steam system at the percent output selected. The control continues to operate in this mode for up to 24 hours or until the Menu, Item or Test button is pressed.

To enable the Max Heat feature, use the following procedure.

1. Press and hold the Test button for more than 3 seconds. At this point, the control flashes the MAX HEAT segment and displays the word OFF.
2. Using the ▲ or ▼ button, select the word On. After 3 seconds the Boiler % is shown.
3. Select the desired boiler output percentage using the ▲ or ▼ buttons.
4. To cancel the Max Heat mode, press the Menu, Item, or Test button.
5. Once the Max Heat mode has either ended or is cancelled, the control resumes normal operation.

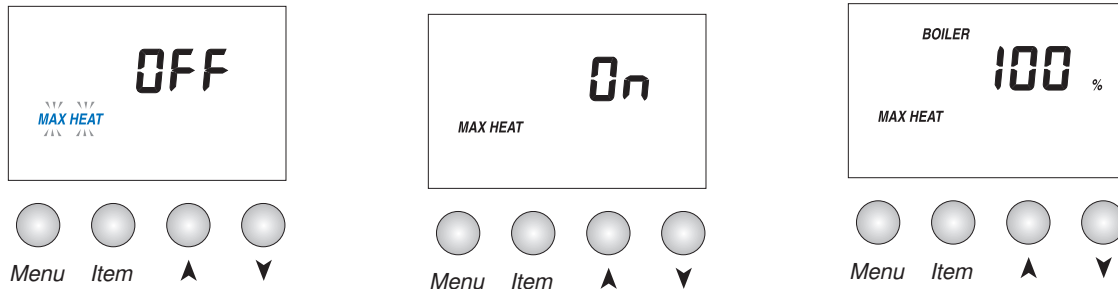

Troubleshooting

When troubleshooting any heating system, it is always a good idea to establish a set routine to follow. By following a consistent routine, many hours of potential headaches can be avoided. Below is an example of a sequence that can be used when diagnosing or troubleshooting problems in a steam heating system.

Establish the Problem

Establish the problem. Get as much information from the customer as possible about the problem. Is there too much heat, not enough heat, or no heat? Is the problem only in one particular zone or area of the building or does the problem affect the entire system? Is this a consistent problem or only intermittent? How long has the problem existed for? This information is critical in correctly diagnosing the problem.

Understanding the Sequence of Operation

Understand the sequence of operation of the system. If a particular zone is not receiving enough heat, which pumps or valves in the system must operate in order to deliver heat to the affected zone? If the zone is receiving too much heat, which pumps, valves or check valves must operate in order to stop the delivery of heat?

Use the Test Routine

Press the Test button on the control and follow the control through the test sequence as described in the Testing section. Pause the control as necessary to ensure that the correct device is operating as it should.

Sketch the Piping in the System

Sketch the piping of the system. This is a relatively simple step that tends to be overlooked, however it can often save hours of time in troubleshooting a system. Note flow directions in the system paying close attention to the location of pumps, check valves, pressure bypass valves and mixing valves. Ensure correct flow direction on all pumps. This is also a very useful step if additional assistance is required.

Document the Control

Document the control for future reference. Before making any adjustments to the control, note down all of the items that the control is currently displaying. This includes items such as error messages, current temperatures and settings, and which devices should be operating as indicated by the LCD. This information is an essential step if additional assistance is required to diagnose the problem.



Isolate the Problem

Isolate the problem between the control and the system. Now that the sequence of operation is known and the system is sketched, is the control operating the proper pumps and valves at the correct times? Is the control receiving the correct signals from the system as to when it should be operating? Are the proper items selected in the menus of the control for the device that is to be operated?





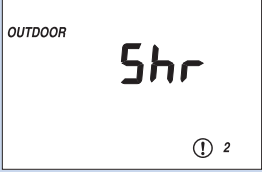
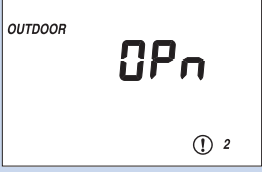
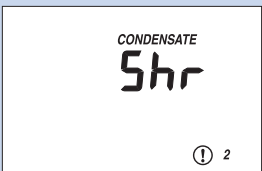

Test the Contacts, Voltages and Sensors

Test the contacts, voltages and sensors. Using a multimeter, ensure that the control is receiving adequate voltage to the power terminals and the demand terminals as noted in the technical data. Use the multimeter to determine if the internal contacts on the control are opening and closing correctly. Follow the instructions in the Testing the Wiring section to simulate closed contacts on the terminal blocks as required. Test the sensors and their wiring as described in the sensor Data Brochures.

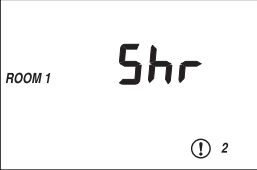
Error Messages (1 of 2)

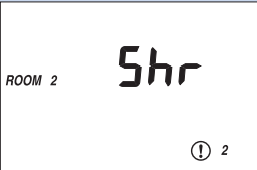
 <p>The display shows 'E01' with a small '1' in a circle below it.</p>	<p>E01 MEMORY ERROR</p> <p>The E01 memory error message causes the Alert 1 High relay to turn on. The control was unable to read a piece of information stored in its memory. Because of this, the control was required to reload the factory settings into all of the items in the ADJUST menu. The control continues operation using the factory defaults until all of the items in the ADJUST menu of the control have been checked by the installer.</p> <p>Note: The Installer/User switch must be set to Installer in order to clear the error.</p>
 <p>The display shows 'OUTDOOR' above 'Shr' with a small '2' in a circle below it.</p>	<p>OUTDOOR SENSOR SHORT CIRCUIT</p> <p>The outdoor sensor short circuit error message causes the Alert 2 Low relay to turn on. The control is no longer able to read the outdoor sensor due to a short circuit. In this case the control assumes an outdoor temperature of 32°F (0°C) and continues operation. Locate and repair the problem as described in the Data Brochure D070. To clear the error message from the control after the sensor has been repaired, press any button.</p>
 <p>The display shows 'OUTDOOR' above 'OPn' with a small '2' in a circle below it.</p>	<p>OUTDOOR SENSOR OPEN CIRCUIT</p> <p>The outdoor sensor open circuit error message causes the Alert 2 Low relay to turn on. The control is no longer able to read the outdoor sensor due to an open circuit. In this case the control assumes an outdoor temperature of 32°F (0°C) and continues operation. Locate and repair the problem as described in the Data Brochure D070. To clear the error message from the control after the sensor has been repaired, press any button.</p>
 <p>The display shows 'CONDENSATE' above 'Shr' with a small '2' in a circle below it.</p>	<p>CONDENSATE SENSOR SHORT CIRCUIT</p> <p>The condensate sensor short circuit error message causes the Alert 2 Low relay to turn on. The control is no longer able to read the condensate sensor due to a short circuit. In this case the control operates as if the condensate sensor was not connected so that there is no time allowed for establishing steam and no lockout differential. Locate and repair the problem as described in the Data Brochure D070. To clear the error message from the control after the sensor has been repaired, press any button.</p>
 <p>The display shows 'CONDENSATE' above 'OPn' with a small '2' in a circle below it.</p>	<p>CONDENSATE SENSOR OPEN CIRCUIT</p> <p>The condensate sensor open circuit error message causes the Alert 2 Low relay to turn on. The control is no longer able to read the condensate sensor due to an open circuit. In this case the control operates as if the condensate sensor was not connected so that there is no time allowed for establishing steam and no lockout differential. Locate and repair the problem as described in the Data Brochure D070. To clear the error message from the control after the sensor has been repaired, press any button.</p> <p>If the condensate sensor was removed on purpose, set the Condensate/Off switch to Off.</p>

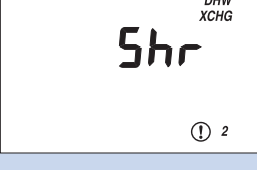
Error Messages (2 of 2)

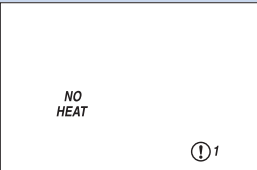
	<p>ROOM 1 SHORT CIRCUIT</p> <p>The room 1 short circuit error message causes the Alert 2 Low relay to turn on. The control is no longer able to read the indoor sensor 1 due to a short circuit. In this case the control will continue operation using indoor sensor 2. If indoor sensor 2 is not available, then the control operates without using indoor temperature feedback. Locate and repair the problem as described in the Data Brochure D076, D077, or D084. To clear the error message from the control after the sensor has been repaired, press any button.</p>
	<p>ROOM 1 OPEN CIRCUIT</p> <p>The room 1 open circuit error message causes the Alert 2 Low relay to turn on. The control is no longer able to read the indoor sensor 1 due to an open circuit. In this case the control will continue operation using indoor sensor 2. If indoor sensor 2 is not available, then the control operates without using indoor temperature feedback. Locate and repair the problem as described in the Data Brochure D076, D077, or D084. To clear the error message from the control after the sensor has been repaired, press any button. If indoor sensor 1 was removed on purpose, set the Indoor S1/Off switch to Off.</p>
	<p>ROOM 2 SHORT CIRCUIT</p> <p>The room 2 short circuit error message causes the Alert 2 Low relay to turn on. The control is no longer able to read the indoor sensor 2 due to a short circuit. In this case the control will continue operation using indoor sensor 1. If indoor sensor 1 is not available, then the control operates without using indoor temperature feedback. Locate and repair the problem as described in the Data Brochure D076, D077, or D084. To clear the error message from the control after the sensor has been repaired, press any button.</p>
	<p>ROOM 2 OPEN CIRCUIT</p> <p>The room 2 open circuit error message causes the Alert 2 Low relay to turn on. The control is no longer able to read the indoor sensor 2 due to an open circuit. In this case the control will continue operation using indoor sensor 1. If indoor sensor 1 is not available, then the control operates without using indoor temperature feedback. Locate and repair the problem as described in the Data Brochure D076, D077, or D084. To clear the error message from the control after the sensor has been repaired, press any button. If indoor sensor 2 was removed on purpose, set the Indoor S2/Off switch to Off.</p>
	<p>DHW EXCHANGE SHORT CIRCUIT</p> <p>The DHW exchange sensor short circuit error message causes the Alert 2 Low relay to turn on. The control is no longer able to read the DHW tankless coil sensor due to a short circuit. In this case the control does not operate the steam boiler for tankless coil domestic hot water. Locate and repair the problem as described in the Data Brochure D070. To clear the error message from the control after the sensor has been repaired, press any button.</p>
	<p>DHW EXCHANGE OPEN CIRCUIT</p> <p>The DHW exchange sensor open circuit error message causes the Alert 2 Low relay to turn on. The control is no longer able to read the DHW tankless coil sensor due to an open circuit. In this case the control does not operate the steam boiler for tankless coil domestic hot water. Locate and repair the problem as described in the Data Brochure D070. To clear the error message from the control after the sensor has been repaired, press any button. If the DHW tankless coil sensor was removed on purpose, set the DHW Tankless Coil Sensor/Off switch to Off.</p>
	<p>NO HEAT</p> <p>The no heat error message causes the Alert 1 High relay to turn on. One of the indoor sensors has measured a temperature below 38°F (3.5°C). To clear the error message from the control, press any button after the indoor sensor temperature has exceeded 38°F (3.5°C).</p>

Technical Data

Steam Control Control 279 One Stage

Literature	— D 279, A 279, D 001, D 070
Control	— Microprocessor control; This is not a safety (limit) control
Packaged weight	— 3.3 lb. (1500 g)
	— Enclosure A, blue modified PVC plastic
Dimensions	— 6-5/8" H x 7-9/16" W x 2-13/16" D (170 x 193 x 72 mm)
Approvals	— CSA C US, meets ICES & FCC regulations for EMI/RFI
Ambient conditions	— Indoor use only, 32 to 122°F (0 to 50°C), < 90% RH non-condensing
Power supply	— 115 V (ac) ± 10% 50/60 Hz 3.5 VA
Relays	— 230 V (ac) 5 A 1/3 hp, pilot duty 240 VA
Sensors	— NTC thermistor, 10 kΩ @ 77°F (25°C ±0.2°C) β=3892
included:	— Outdoor Sensor 070 and Universal Sensor 071
Optional Devices	— tekmar type #: 071, 076, 077, 078, 082, 084

Limited Warranty and Product Return Procedure

Limited Warranty *The liability of tekmar under this warranty is limited. The Purchaser, by taking receipt of any tekmar product ("Product"), acknowledges the terms of the Limited Warranty in effect at the time of such Product sale and acknowledges that it has read and understands same.*

The tekmar Limited Warranty to the Purchaser on the Products sold hereunder is a manufacturer's pass-through warranty which the Purchaser is authorized to pass through to its customers. Under the Limited Warranty, each tekmar Product is warranted against defects in workmanship and materials if the Product is installed and used in compliance with tekmar's instructions, ordinary wear and tear excepted. The pass-through warranty period is for a period of twenty-four (24) months from the production date if the Product is not installed during that period, or twelve (12) months from the documented date of installation if installed within twenty-four (24) months from the production date.

The liability of tekmar under the Limited Warranty shall be limited to, at tekmar's sole discretion: the cost of parts and labor provided by tekmar to repair defects in materials and/or workmanship of the defective product; or to the exchange of the defective product for a warranty replacement product; or to the granting of credit limited to the original cost of the defective product, and such repair, exchange or credit shall be the sole remedy available from tekmar, and, without limiting the foregoing in any way, tekmar is not responsible, in contract, tort or strict product liability, for any other losses, costs, expenses, inconveniences, or damages, whether direct, indirect, special, secondary, incidental or consequential, arising from ownership or use of the product, or from defects in workmanship or materials, including any liability for fundamental breach of contract.

The pass-through Limited Warranty applies only to those defective Products returned to tekmar during the warranty period. This Limited Warranty does not cover the cost of the parts or labor to remove or transport the defective Product, or to reinstall the repaired or replacement Product, all such costs and expenses being subject to Purchaser's agreement and warranty with its customers.

Any representations or warranties about the Products made by Purchaser to its customers which are different from or in excess of the tekmar Limited Warranty are the Purchaser's sole responsibility and obligation. Purchaser shall indemnify and hold tekmar harmless from and against any and all claims, liabilities and damages of any kind or nature which arise out of or are related to any such representations or warranties by Purchaser to its customers.

The pass-through Limited Warranty does not apply if the returned Product has been damaged by negligence by persons other than tekmar, accident, fire, Act of God, abuse or misuse; or has been damaged by modifications, alterations or attachments made subsequent to purchase which have not been authorized by tekmar; or if the Product was not installed in compliance with tekmar's instructions and/or the local codes and ordinances; or if due to defective installation of the Product; or if the Product was not used in compliance with tekmar's instructions.

THIS WARRANTY IS IN LIEU OF ALL OTHER WARRANTIES, EXPRESS OR IMPLIED, WHICH THE GOVERNING LAW ALLOWS PARTIES TO CONTRACTUALLY EXCLUDE, INCLUDING, WITHOUT LIMITATION, IMPLIED WARRANTIES OF MERCHANTABILITY AND FITNESS FOR A PARTICULAR PURPOSE, DURABILITY OR DESCRIPTION OF THE PRODUCT, ITS NON-INFRINGEMENT OF ANY RELEVANT PATENTS OR TRADEMARKS, AND ITS COMPLIANCE WITH OR NON-VIOLATION OF ANY APPLICABLE ENVIRONMENTAL, HEALTH OR SAFETY LEGISLATION; THE TERM OF ANY OTHER WARRANTY NOT HEREBY CONTRACTUALLY EXCLUDED IS LIMITED SUCH THAT IT SHALL NOT EXTEND BEYOND TWENTY-FOUR (24) MONTHS FROM THE PRODUCTION DATE, TO THE EXTENT THAT SUCH LIMITATION IS ALLOWED BY THE GOVERNING LAW.

Product Warranty Return Procedure All Products that are believed to have defects in workmanship or materials must be returned, together with a written description of the defect, to the tekmar Representative assigned to the territory in which such Product is located. If tekmar receives an inquiry from someone other than a tekmar Representative, including an inquiry from Purchaser (if not a tekmar Representative) or Purchaser's customers, regarding a potential warranty claim, tekmar's sole obligation shall be to provide the address and other contact information regarding the appropriate Representative.



tekmar Control Systems Ltd., Canada
tekmar Control Systems, Inc., U.S.A.
Head Office: 5100 Silver Star Road
Vernon, B.C. Canada V1B 3K4
(250) 545-7749 Fax. (250) 545-0650
Web Site: www.tekmarcontrols.com

