



Heating and Air Conditioning

## Technical Guide

### SPLIT-SYSTEM

### EVAPORATOR BLOWERS

**K2EU060, K4EU090, K3EU120 &**

**K3EU180**

**5 THRU 15 NOMINAL TONS**

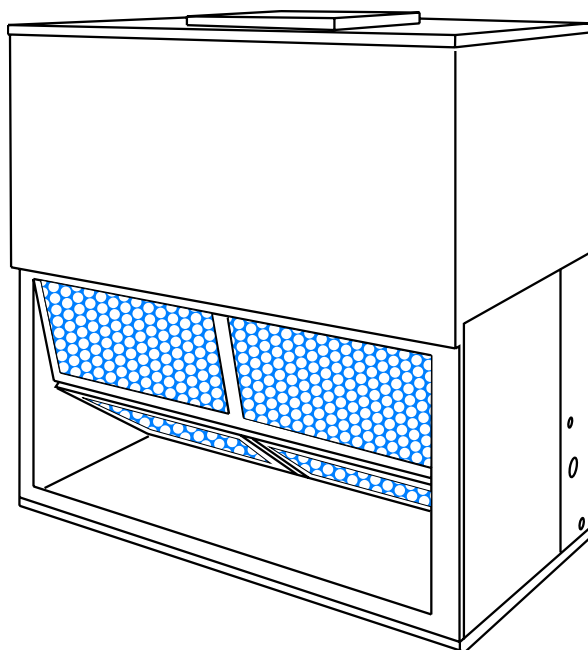

## DESCRIPTION

These completely assembled units include a well-insulated cabinet, a DX cooling coil with copper tubes and aluminum fins, expansion valve(s), distributor(s), throwaway filters, a centrifugal blower, a blower motor, an adjustable belt drive, a blower motor contactor and a small holding charge of refrigerant-22.

The units are shipped in the vertical position ready for field installation. They can be installed for horizontal operation by reversing the position of the solid bottom panel with the return air duct flange on the front of the unit.

## ACCESSORIES—FIELD INSTALLED

### SUPPLY AIR PLENUMS

These fully insulated plenums are available for free standing units located within the conditioned space, are shipped knocked-down for easy field assembly, are finished to match the exterior of the basic unit, and have double deflection grills that can be adjusted to vary the throw, spread and drop of the supply air.

### RETURN AIR GRILLS

These expanded metal grills are available for free standing units located within the conditioned space, are finished to match the exterior of the basic unit and are shipped in one piece for easy installation.

### BASES

Bases are available to raise vertical units above the floor. Outdoor air may be introduced through these bases by cutting an access opening to accommodate the outdoor air duct connection. These bases are finished to match the exterior of the basic unit. They may have to be insulated in the field for certain applications.

### THREE-PHASE ELECTRIC HEATERS

Electric heaters are available in several capacities to provide maximum flexibility. Both the air conditioning unit and the heater can be selected to precisely match the cooling and heating requirements of the conditioned space. These heaters are designed for easy field installation over the supply air opening of the unit. They have been tested by and will be shipped with a CSA label. Every heater will be fully protected against excessive current and temperature by fuses and two high limit thermostats.

Units with electric heat will require only one power supply for both the heating elements and the supply air blower motor, and the power wiring can be protected by either dual element/time delay fuses or an inverse time circuit breaker.

## TABLE OF CONTENTS

DESCRIPTION .....	1
ACCESSORIES—FIELD INSTALLED .....	1
NOMENCLATURE .....	3
APPLICATION FLEXIBILITY .....	4

### LIST OF FIGURES

<u>Fig. #</u>	<u>Pg. #</u>
1 VERTICAL AND HORIZONTAL APPLICATION KEU060, 090 & 120 .....	4
2 VERTICAL AND HORIZONTAL APPLICATION KEU180 .....	4
3 SUSPENSION MOUNTING (HORIZONTAL) - KEU060, 090 AND 120 .....	5
4 SUSPENSION ACCESSORY (HORIZONTAL) - KEU180 .....	6
5 UNIT DIMENSIONS KEU060 .....	16
6 UNIT DIMENSIONS KEU090 & 120 .....	17
7 UNIT DIMENSIONS KEU180 .....	18
8 ACCESSORY DIMENSIONS .....	19
9 RETURN AIR GRILL .....	20
10 BASE ACCESSORY .....	20
11 STEAM COIL .....	21
12 HOT WATER COIL .....	21

### LIST OF TABLES

<u>Tbl. #</u>		<u>Pg. #</u>
1	UNIT SUSPENSION MOUNTING (HORIZONTAL APPLICATION) WEIGHTS .....	5
2	KEU OPERATING WEIGHTS (LBS.) .....	5
3	SOUND POWER RATINGS .....	6
4	HEATING CAPACITY - ELECTRIC HEAT ACCESSORY .....	7
5	STEAM COIL CAPACITY, MBH@2 PSIG .....	8
6	HOT WATER CAPACITY, MBH .....	8
7	PRESSURE DROP VS. GPM .....	8
8	CAPACITY CORRECTION VS. GPM .....	8
9	SUPPLY AIR BLOWER PERFORMANCE - KEU060 (5 TON) .....	9
10	SUPPLY AIR BLOWER PERFORMANCE - KEU090 (7.5 TON) .....	10
11	SUPPLY AIR BLOWER PERFORMANCE - KEU120 (10 TON) .....	11
12	SUPPLY AIR BLOWER PERFORMANCE - KEU180 (15 TON) .....	12
13	STATIC RESISTANCE FOR UNIT ACCESSORIES (IWG) - KEU060-120 .....	13
14	STATIC RESISTANCE FOR UNIT ACCESSORIES (IWG) - KEU180 .....	13
15	SUPPLY AIR PLENUM PERFORMANCE DATA ...	14
16	BLOWER MOTOR AND DRIVE DATA .....	14
17	KEU PHYSICAL DATA .....	15
18	UNIT CLEARANCES KEU060 .....	16
19	UNIT CLEARANCES KEU090 & 120 .....	17
20	UNIT CLEARANCES KEU180 .....	18
21	ELECTRIC HEATER DIMENSIONS KEU060, 090, 120 & 180 .....	20
22	KEU ELECTRICAL DATA .....	22

## NOMENCLATURE

### York Indoor Split System Product Nomenclature

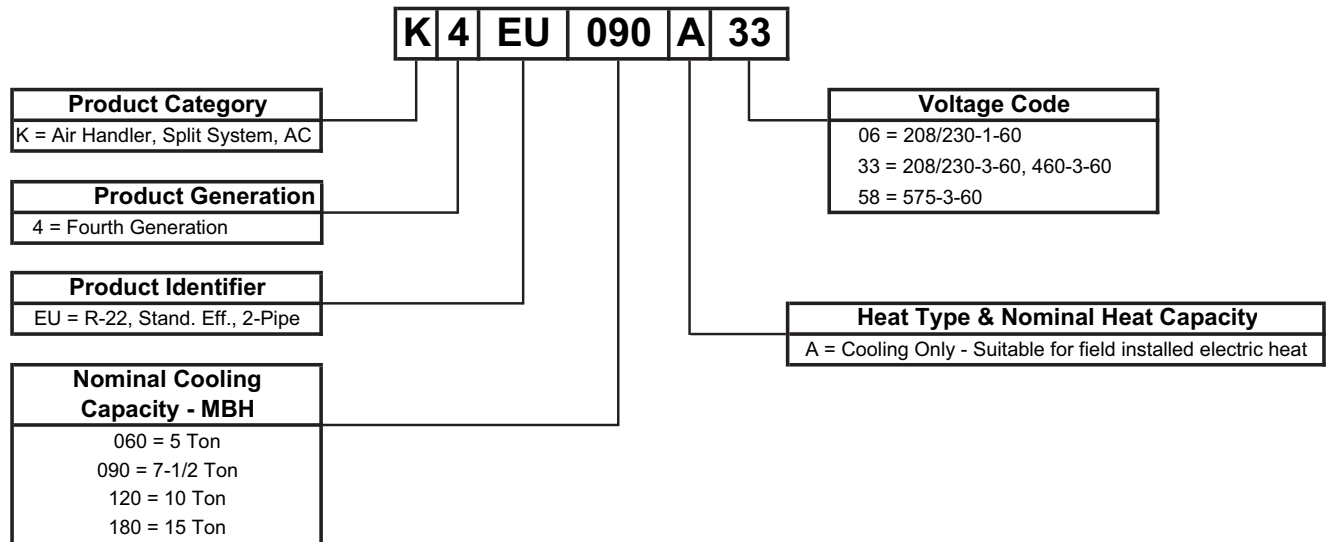

## ACCESSORIES-FIELD INSTALLED (CONT.)

### HOT WATER COILS

These drainable coils have 2 rows of 1/2" copper tubes, 12 aluminum fins per inch, a casing that is finished to match the exterior of the basic unit, but no water control valve. The coils slide out of their casings for easy field installation. They should be mounted over the return air opening on 5, 7-1/2 and 10-ton units—between the unit coil and blower sections on 15-ton units.

### STEAM COILS

These non-freeze coils have 1 row of 1" copper tubes, a 5/8" copper tube inside each 1" tube to distribute the steam evenly across the entire length of the coil, 8 aluminum fins per inch, a casing that is finished to match the exterior of the basic unit,

but no steam control valve. The coils slide out of their casings for easy field installation and are pitched in their casings to facilitate condensate drainage. They should be mounted over the return air opening on 5, 7-1/2 and 10-ton units—between the unit coil and blower sections on 15-ton units.

### SUSPENSION KIT

Suspension kit 1HH0451 is available for 15-ton units installed horizontally. The accessory includes two channel iron supports and the hardware to secure them to the top of the unit. The hanger rods must be supplied by the field.

### THERMOSTATS

Wall-mounted thermostats and subbases (24-volt) with system and fan switches are available to control the operation of these split system air conditioners.

## APPLICATION FLEXIBILITY

### MODELS 5, 7-1/2 & 10 TON

These units are built in a single cabinet with two condensate drain pans. This allows the units to be installed in either the vertical or horizontal position for maximum flexibility.

On vertical applications, the air velocity across the cooling coil keeps the condensate from dripping off the finned surface onto the filters.

On horizontal applications, the unit must be installed with the condensate drain pan under the entire cooling coil.

- The Supply Air Plenum and the Return Air Grill accessories can be used on either arrangement.
- The Base accessory can only be used on the vertical arrangement.

Units installed horizontally are designed for ceiling suspension. Four 3/8"-16 weld nuts are provided in the angle supports on the front of the unit (the side with the logo). Knockouts are provided in the exterior panels for access to these weld nuts. The hanger rods must be supplied in the field.

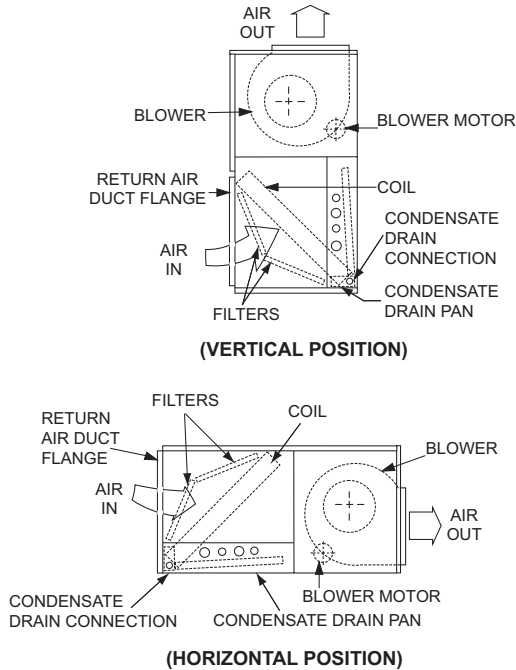
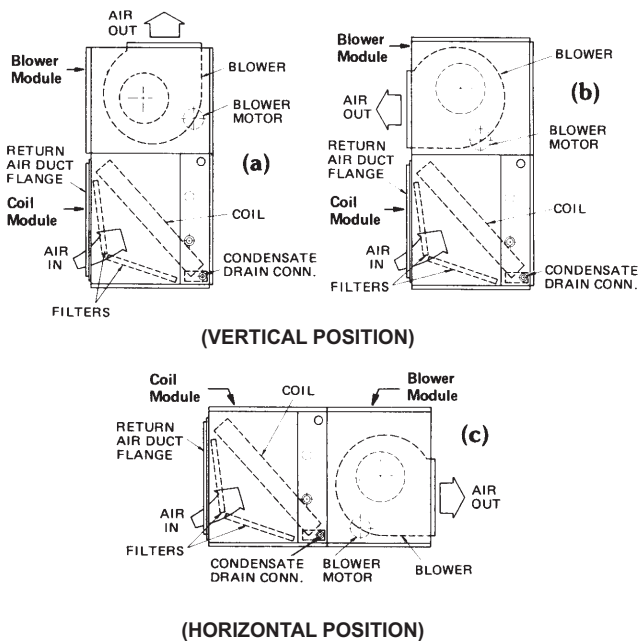

**FIGURE 1 - VERTICAL AND HORIZONTAL APPLICATION KEU060, 090 & 120**

### MODEL 15 TON

These units have two distinct modules . . . a blower module and a coil module. Although the unit is always shipped in the vertical position with a vertical air discharge as shown in illustration (a), the blower module can be repositioned in the field as shown in illustrations (b) and (c) for maximum flexibility.

- The Supply Air Plenum, Return Air Grill and Base accessories can be applied on arrangement (a).
- The Return Air Grill and Base accessories can be applied on arrangement (b).
- The Supply Air Plenum, Return Air Grill and Suspension accessories can be applied on arrangement (c).



**FIGURE 2 - VERTICAL AND HORIZONTAL APPLICATION KEU180**

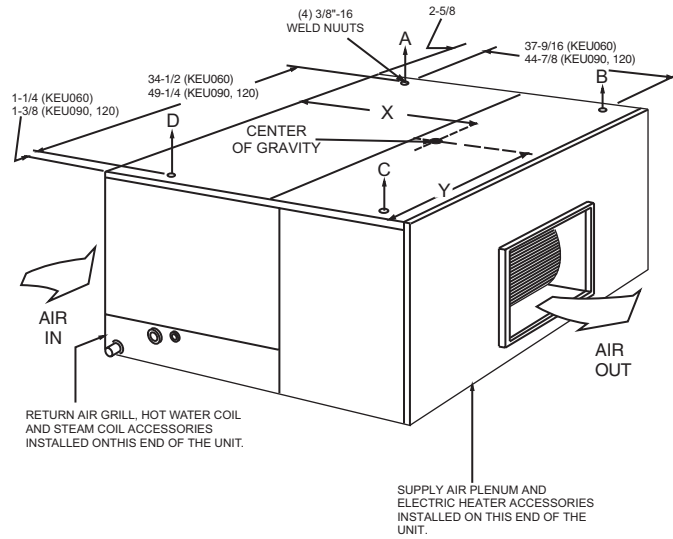

**FIGURE 3 - SUSPENSION MOUNTING (HORIZONTAL) - KEU060, 090 AND 120**

**TABLE 1: UNIT SUSPENSION MOUNTING (HORIZONTAL APPLICATION) WEIGHTS**

Unit Model	Shipping Weight (lb)	Operating Weight (lb)	CG (in)		4-Point Loading (lb)			
			X	Y	A	B	C	D
K*EU060	225	210	22.50	15.00	47	51	58	53
K*EU090	340	235	26.50	24.00	78	84	84	78
K*EU120	370	355	26.50	24.00	86	92	92	86
K*EU180	440	425	26.50	24.00	104	77	104	141

**TABLE 2: KEU OPERATING WEIGHTS (LBS.)**

MODEL		060	090	120	180	
<b>BASIC UNIT</b>	(Cooling Only)	210	325	325	425	
<b>ACCESSORIES</b>	Base	45	55	55	65	
	Return Air Grill	10	15	15	20	
	Supply Air Plenum	90	100	100	115	
	Hot Water Coil	70	105	105	135	
	Steam Coil	80	115	115	145	
	Electric Heater	10 KW	66			
		16 KW	70			
		26 KW	74			
36 KW		77				
72 KW		125				

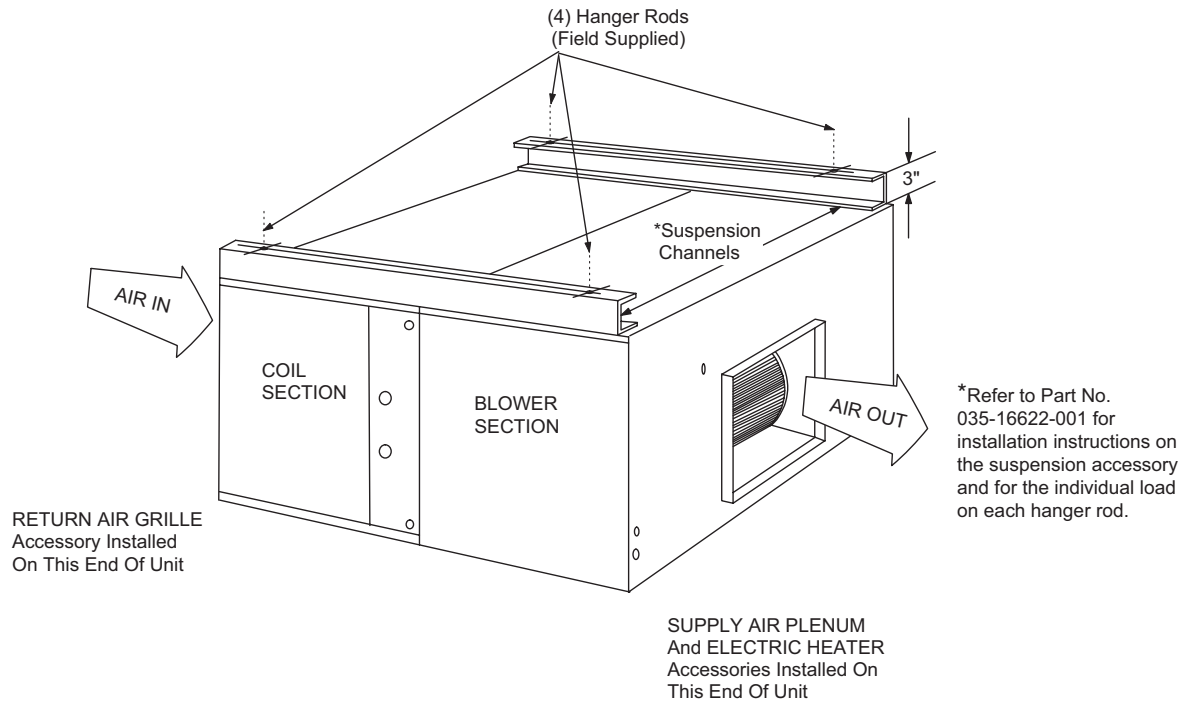

**FIGURE 4 - SUSPENSION ACCESSORY (HORIZONTAL) - KEU180**

**TABLE 3: SOUND POWER RATINGS**

UNIT MODEL	CFM	ESP	BLOWER		SOUND POWER (dB 10 <sup>-12</sup> WATTS)											
					OCTAVE BAND CENTERLINE FREQUENCY (HZ)										SWL dB(a)	dB(A) @ 10 FT. <sup>1</sup>
					IWG	RPM	BHP	63	125	250	500	1,000	2,000	4,000		
060	2,000	0.50	940	0.70	88	88	78	71	73	66	61	56	77	44		
090	3,000	0.60	750	1.05	88	88	78	73	71	66	61	56	77	45		
120	4,000	0.70	850	1.75	91	91	81	74	76	69	64	59	81	48		
180	6,000	0.75	750	2.75	95	95	85	80	78	73	68	63	84	52		

1. At a distance of 10 feet from the blower.

**NOTE:** These values have been accessed using a model of sound propagation from a point source into the hemispheric free field. The dBA values provided are for reference only. Calculation of dBA values cover matters of system design and the fan manufacturer has no way of knowing the details of each system. This constitutes an exception to any specification or guarantee requiring a dBA value or sound data in any other form than sound power level ratings.

**TABLE 4: HEATING CAPACITY - ELECTRIC HEAT ACCESSORY**

UNIT MODEL	HEATER MODEL		VOLTAGE TEST	NOMINAL RATINGS <sup>1</sup>		CAPACITY			
						1ST STAGE		2ND STAGE	
				KW	MBH	KW	MBH	KW	MBH
060	2HT045010	25	208 / 240 <sup>2</sup>	10	34.2	10	34.2	-	-
	2HT045016	25	208 / 240 <sup>2</sup>	16	54.7	10	34.2	6	20.5
	2HT045026	25	208 / 240 <sup>2</sup>	26	88.9	16	54.7	10	34.2
090, 120	2HS045010	25	208 / 240 <sup>2</sup>	10	34.2	10	34.2	-	-
		46	480 <sup>3</sup>						
		58	600 <sup>4</sup>						
	2HS045016	25	208 / 240 <sup>2</sup>	16	54.7	10	34.2	6	20.5
		46	480 <sup>3</sup>						
		58	600 <sup>4</sup>						
	2HS045026	25	208 / 240 <sup>2</sup>	26	88.9	16	54.7	10	34.2
		46	480 <sup>3</sup>						
		58	600 <sup>4</sup>						
	2HS045036	25	208 / 240 <sup>2</sup>	36	123	16	54.7	20	68.3
		46	480 <sup>3</sup>						
		58	600 <sup>4</sup>						
180	2HS045010	25	208 / 240 <sup>2</sup>	10	34.2	10	34.2	-	-
		46	280 <sup>3</sup>						
		58	600 <sup>4</sup>						
	2HS045016	25	208 / 240 <sup>2</sup>	16	54.7	10	34.2	6	20.5
		46	280 <sup>3</sup>						
		58	600 <sup>4</sup>						
	2HS045026	25	208 / 240 <sup>2</sup>	26	88.9	16	54.7	10	34.2
		46	280 <sup>3</sup>						
		58	600 <sup>4</sup>						
	2HS045036	25	208 / 240 <sup>2</sup>	36	123	16	54.7	20	68.3
		46	280 <sup>3</sup>						
		58	600 <sup>4</sup>						
2HS045072	25	208 / 240 <sup>2</sup>	72	246	36	123	36	123	
	46	280 <sup>3</sup>							
	58	600 <sup>4</sup>							

1. Capacity Ratings do not include the heat generated by the air blower motor.
2. For 208 volts, multiply the MBH and KW by (208/240)<sup>2</sup> or 0.751.  
For 230 volts, multiply the MBH and KW by (230/240)<sup>2</sup> or 0.918.
3. For 460 volts, multiply the MBH and KW by (460/480)<sup>2</sup> or 0.918.
4. For 575 volts, multiply the MBH and KW by (575/600)<sup>2</sup> or 0.918.

**TABLE 5: STEAM COIL CAPACITY<sup>1</sup>, MBH@2 PSIG<sup>2</sup>**

STEAM COIL MODEL	UNIT MODEL	CFM	DRY BULB TEMPERATURE OF AIR ENTERING COIL, °F			
			10	30	50	70
1NF0450	060	1600	104.0	94.0	83.9	73.9
		2000	115.2	104.0	93.1	81.9
		2400	124.9	113.0	100.9	89.0
1NF0451	090	2400	172.2	155.5	139.1	122.4
		3000	191.2	172.6	154.3	136.0
		3600	207.5	187.1	167.4	147.4
	120	3200	196.4	177.6	158.8	140.0
		4000	217.3	195.3	175.3	154.8
		4800	236.1	212.9	190.4	167.8
1NF0452	180	4800	298.2	268.4	236.7	211.5
		6000	329.1	297.0	265.6	234.1
		7200	356.4	321.8	287.9	254.0

1. These capacities do not include any blower motor heat.
2. Multiply these capacities by the following factors to correct for higher steam pressures.

Steam Pressure, psig	5	10	15	20	25
Capacity correction factor	1.05	1.12	1.19	1.25	1.30

NOTE: Steam rate (lb./hr.) = 1.025 x MBH

CAUTION: Do NOT operate a motor above its nominal HP rating when a unit is equipped with a steam coil accessory.

**TABLE 6: HOT WATER CAPACITY<sup>1</sup>, MBH**

WATER COIL MODEL	UNIT MODEL	GPM	CFM	ENTERING WATER TEMP. MINUS ENTERING AIR TEMP., °F				
				70	90	110	130	150
1HW0450	060	10	1600	46.5	60.4	74.6	89.0	101.8
			2000	51.7	67.2	83.0	99.2	113.4
			2400	56.0	73.0	90.4	107.9	123.3
1HW0451	090	15	2400	78.0	101.3	124.7	148.5	169.7
			3000	87.7	113.3	139.6	166.6	190.4
			3600	95.5	124.0	153.0	182.1	208.1
	120	15	3200	90.3	117.1	144.6	172.1	196.6
			4000	100.2	130.2	160.7	191.3	218.6
			4800	108.3	140.9	174.3	207.5	237.4
1HW0452	180	20	4800	135.5	175.1	215.8	257.4	294.1
			6000	150.0	195.0	240.3	285.9	326.6
			7200	162.4	210.8	260.4	309.8	354.3

1. These capacities do not include any blower motor heat.

NOTE: Water Temperature Drop, °F = 2 x MBH/GPM

CAUTION: Do NOT operate a motor above its nominal HP rating when a unit is equipped with a hot water coil accessory.

**TABLE 7: PRESSURE DROP VS. GPM**

1HW0450	GPM	10	20	30
	Pressure Drop, PSI	.10	.32	.67
1HW0451	GPM	15	30	45
	Pressure Drop, PSI	.17	.58	1.22
1HW0452	GPM	20	40	60
	Pressure Drop, PSI	.20	.67	1.41

**TABLE 8: CAPACITY CORRECTION VS. GPM**

1HW0450	GPM	20	30
	Capacity Correction	1.12	1.16
1HW0451	GPM	30	45
	Capacity Correction	1.11	1.15
1HW0452	GPM	40	60
	Capacity Correction	1.12	1.17



**TABLE 9: SUPPLY AIR BLOWER PERFORMANCE - KEU060 (5 TON)**

CFM	EXTERNAL STATIC PRESSURE											
	0.2			0.4			0.6			0.8		
	RPM	W	BHP	RPM	W	BHP	RPM	W	BHP	RPM	W	BHP
1400	677	74	0.08	753	174	0.19	831	268	0.29	912	355	0.38
1600	725	225	0.24	801	325	0.35	879	419	0.45	959	506	0.54
1800	773	366	0.39	849	466	0.50	927	560	0.60	1008	647	0.69
2000	822	507	0.54	898	607	0.65	975	701	0.75	1056	789	0.85
2200	871	657	0.70	947	757	0.81	1025	851	0.91	1106	938	1.01
2400	922	818	0.88	997	918	0.99	1075	1012	1.09	1156	1100	1.18
2600	972	994	1.07	1048	1094	1.17	1126	1188	1.27	1207	1276	1.37
2800	1024	1187	1.27	1100	1286	1.38	1178	1380	1.48	1258	1468	1.57
3000	1076	1395	1.50	1152	1495	1.60	1230	1589	1.70	1311	1677	1.80
3200	1129	1622	1.74	1205	1721	1.85	1283	1815	1.95	----	----	----

CFM	EXTERNAL STATIC PRESSURE											
	1.0			1.2			1.4			1.6		
	RPM	W	BHP	RPM	W	BHP	RPM	W	BHP	RPM	W	BHP
1400	997	435	0.47	1086	507	0.54	1181	570	0.61	1282	622	0.67
1600	1044	586	0.63	1134	658	0.71	1228	721	0.77	1329	774	0.83
1800	1092	727	0.78	1182	799	0.86	1276	861	0.92	1377	914	0.98
2000	1141	869	0.93	1230	940	1.01	1325	1003	1.08	1426	1056	1.13
2200	1191	1018	1.09	1280	1090	1.17	1375	1153	1.24	1476	1205	1.29
2400	1241	1180	1.27	1330	1251	1.34	1425	1314	1.41	1526	1367	1.47
2600	1292	1356	1.45	1381	1427	1.53	1476	1490	1.60	1577	1543	1.66
2800	1343	1548	1.66	1433	1620	1.74	1527	1682	1.80	1628	1735	1.86
3000	1395	1757	1.88	1485	1828	1.96	----	----	----	----	----	----
3200	----	----	----	----	----	----	----	----	----	----	----	----

 Exceeds the BHP limitation.

**TABLE 10: SUPPLY AIR BLOWER PERFORMANCE - KEU090 (7.5 TON)**

CFM	EXTERNAL STATIC PRESSURE											
	0.2			0.4			0.6			0.8		
	RPM	W	BHP	RPM	W	BHP	RPM	W	BHP	RPM	W	BHP
2200	561	281	0.30	612	400	0.43	670	530	0.57	734	661	0.71
2400	579	414	0.44	630	533	0.57	688	663	0.71	752	794	0.85
2600	599	542	0.58	649	662	0.71	707	792	0.85	771	922	0.99
2800	619	666	0.71	670	786	0.84	728	916	0.98	792	1047	1.12
3000	640	786	0.84	691	905	0.97	749	1035	1.11	813	1166	1.25
3200	662	901	0.97	713	1021	1.10	771	1151	1.23	835	1282	1.37
3400	684	1013	1.09	735	1132	1.21	793	1262	1.35	857	1393	1.49
3600	706	1120	1.20	757	1239	1.33	815	1369	1.47	879	1500	1.61
3800	728	1223	1.31	779	1342	1.44	837	1472	1.58	900	1603	1.72
4000	750	1322	1.42	800	1441	1.55	859	1571	1.69	922	1702	1.83
4200	771	1418	1.52	822	1537	1.65	880	1667	1.79	944	1798	1.93
4400	792	1510	1.62	843	1629	1.75	901	1759	1.89	965	1890	2.03
4600	813	1599	1.72	864	1718	1.84	922	1848	1.98	986	1979	2.12

CFM	EXTERNAL STATIC PRESSURE											
	1.0			1.2			1.4			1.6		
	RPM	W	BHP	RPM	W	BHP	RPM	W	BHP	RPM	W	BHP
2200	801	783	0.84	869	886	0.95	936	962	1.03	1000	999	1.07
2400	819	916	0.98	887	1019	1.09	954	1095	1.17	1018	1132	1.21
2600	838	1044	1.12	906	1148	1.23	973	1223	1.31	1038	1261	1.35
2800	859	1169	1.25	927	1272	1.36	994	1348	1.45	1058	1385	1.49
3000	880	1288	1.38	948	1392	1.49	1015	1467	1.57	1079	1505	1.61
3200	902	1404	1.51	970	1507	1.62	1037	1583	1.70	1101	1620	1.74
3400	924	1515	1.63	992	1618	1.74	1059	1694	1.82	1123	1731	1.86
3600	945	1622	1.74	1014	1725	1.85	1081	1801	1.93	1145	1838	1.97
3800	967	1725	1.85	1036	1828	1.96	1103	1904	2.04	1167	1941	2.08
4000	989	1824	1.96	1057	1928	2.07	1124	2003	2.15	1189	2041	2.19
4200	1011	1920	2.06	1079	2023	2.17	1146	2099	2.25	1210	2136	2.29
4400	1032	2012	2.16	1100	2116	2.27	----	----	----	----	----	----
4600	1052	2101	2.25	----	----	----	----	----	----	----	----	----

 Exceeds the BHP limitation.

**TABLE 11: SUPPLY AIR BLOWER PERFORMANCE - KEU120 (10 TON)**

CFM	EXTERNAL STATIC PRESSURE											
	0.2			0.4			0.6			0.8		
	RPM	W	BHP	RPM	W	BHP	RPM	W	BHP	RPM	W	BHP
2800	571	122	0.13	630	332	0.36	682	489	0.52	733	618	0.66
3000	595	349	0.37	654	559	0.60	706	716	0.77	756	845	0.91
3200	619	558	0.60	678	768	0.82	730	925	0.99	780	1054	1.13
3400	643	753	0.81	702	964	1.03	754	1120	1.20	804	1249	1.34
3600	667	939	1.01	726	1149	1.23	778	1306	1.40	829	1435	1.54
3800	692	1119	1.20	751	1329	1.43	803	1485	1.59	853	1614	1.73
4000	716	1294	1.39	775	1504	1.61	827	1661	1.78	877	1790	1.92
4200	740	1468	1.57	799	1678	1.80	852	1834	1.97	902	1963	2.11
4400	765	1641	1.76	824	1851	1.99	876	2008	2.15	926	2136	2.29
4600	789	1815	1.95	848	2025	2.17	900	2182	2.34	950	2310	2.48
4800	813	1991	2.14	872	2201	2.36	924	2357	2.53	974	2486	2.67
5000	837	2169	2.33	896	2380	2.55	948	2536	2.72	998	2665	2.86
5200	861	2352	2.52	920	2562	2.75	972	2718	2.92	1022	2847	3.05
5400	884	2538	2.72	943	2748	2.95	995	2905	3.12	1045	3033	3.25
5600	907	2728	2.93	966	2939	3.15	1019	3095	3.32	1069	3224	3.46

CFM	EXTERNAL STATIC PRESSURE											
	1.0			1.2			1.4			1.6		
	RPM	W	BHP	RPM	W	BHP	RPM	W	BHP	RPM	W	BHP
2800	786	744	0.80	846	893	0.96	920	1092	1.17	1010	1364	1.46
3000	809	971	1.04	870	1121	1.20	943	1319	1.41	1034	1592	1.71
3200	833	1180	1.27	894	1329	1.43	967	1528	1.64	1057	1800	1.93
3400	857	1375	1.48	918	1525	1.64	991	1723	1.85	1082	1996	2.14
3600	882	1561	1.67	942	1711	1.84	1016	1909	2.05	1106	2182	2.34
3800	906	1741	1.87	967	1890	2.03	1040	2088	2.24	1130	2361	2.53
4000	930	1916	2.06	991	2066	2.22	1064	2264	2.43	1155	2536	2.72
4200	955	2090	2.24	1016	2239	2.40	1089	2437	2.61	1179	2710	2.91
4400	979	2263	2.43	1040	2412	2.59	1113	2610	2.80	1203	2883	3.09
4600	1003	2437	2.61	1064	2586	2.77	1137	2784	2.99	1228	3057	3.28
4800	1027	2613	2.80	1088	2762	2.96	1161	2960	3.18	1252	3233	3.47
5000	1051	2791	2.99	1112	2941	3.15	1185	3139	3.37	----	----	----
5200	1075	2973	3.19	1136	3123	3.35	----	----	----	----	----	----
5400	1098	3160	3.39	----	----	----	----	----	----	----	----	----
5600	----	----	----	----	----	----	----	----	----	----	----	----

 Exceeds the BHP limitation.

TABLE 12: SUPPLY AIR BLOWER PERFORMANCE - KEU180 (15 TON)

CFM	EXTERNAL STATIC PRESSURE											
	0.2			0.4			0.6			0.8		
	RPM	W	BHP	RPM	W	BHP	RPM	W	BHP	RPM	W	BHP
4000	555	382	0.41	594	620	0.67	633	851	0.91	676	1085	1.16
4200	562	616	0.66	600	854	0.92	640	1085	1.16	683	1319	1.42
4400	569	828	0.89	608	1066	1.14	648	1297	1.39	690	1531	1.64
4600	577	1022	1.10	616	1260	1.35	656	1491	1.60	698	1725	1.85
4800	586	1202	1.29	624	1440	1.55	664	1671	1.79	707	1905	2.04
5000	595	1372	1.47	634	1610	1.73	673	1841	1.97	716	2075	2.23
5200	604	1533	1.64	643	1771	1.90	683	2002	2.15	726	2236	2.40
5400	614	1689	1.81	653	1927	2.07	693	2158	2.31	735	2392	2.57
5600	624	1841	1.97	663	2079	2.23	703	2310	2.48	745	2544	2.73
5800	635	1991	2.14	673	2228	2.39	713	2459	2.64	756	2694	2.89
6000	645	2140	2.30	684	2378	2.55	724	2609	2.80	766	2843	3.05
6200	656	2290	2.46	695	2528	2.71	735	2759	2.96	777	2993	3.21
6400	667	2442	2.62	706	2679	2.87	746	2910	3.12	788	3145	3.37
6600	679	2596	2.78	717	2833	3.04	757	3064	3.29	800	3299	3.54
6800	690	2753	2.95	729	2991	3.21	768	3222	3.46	811	3456	3.71
7000	701	2915	3.13	740	3153	3.38	780	3384	3.63	823	3618	3.88

CFM	EXTERNAL STATIC PRESSURE											
	1.0			1.2			1.4			1.6		
	RPM	W	BHP	RPM	W	BHP	RPM	W	BHP	RPM	W	BHP
4000	723	1333	1.43	775	1604	1.72	833	1910	2.05	900	2258	2.42
4200	729	1567	1.68	781	1839	1.97	840	2144	2.30	907	2493	2.67
4400	737	1779	1.91	789	2051	2.20	848	2356	2.53	915	2704	2.90
4600	745	1973	2.12	797	2245	2.41	856	2550	2.74	923	2899	3.11
4800	754	2153	2.31	806	2425	2.60	864	2730	2.93	931	3079	3.30
5000	763	2323	2.49	815	2594	2.78	873	2899	3.11	940	3248	3.48
5200	772	2484	2.66	824	2755	2.96	883	3061	3.28	950	3409	3.66
5400	782	2640	2.83	834	2911	3.12	893	3216	3.45	960	3565	3.82
5600	792	2792	2.99	844	3063	3.29	903	3368	3.61	970	3717	3.99
5800	802	2942	3.16	854	3213	3.45	913	3518	3.77	980	3867	4.15
6000	813	3091	3.32	865	3362	3.61	924	3667	3.93	991	4016	4.31
6200	824	3241	3.48	876	3512	3.77	935	3817	4.10	1002	4166	4.47
6400	835	3392	3.64	887	3664	3.93	946	3969	4.26	1013	4318	4.63
6600	846	3547	3.80	898	3818	4.10	957	4123	4.42	1024	4472	4.80
6800	858	3704	3.97	910	3976	4.26	968	4281	4.59	1035	4629	4.97
7000	869	3866	4.15	921	4137	4.44	980	4442	4.77	1047	4791	5.14

Exceeds the BHP limitation.

**TABLE 13: STATIC RESISTANCE FOR UNIT ACCESSORIES (IWG) - KEU060-120**

CFM	Electric Heat KW				Supply Air Plenum	Return Air Grill	Hot Water Coil	Steam Coil
	10	16	26	36				
2200	0.01	0.01	0.03	0.04	0.02	0.02	0.07	0.11
2400	0.01	0.02	0.03	0.05	0.03	0.03	0.09	0.13
2600	0.01	0.02	0.04	0.06	0.03	0.03	0.10	0.15
2800	0.01	0.03	0.04	0.07	0.04	0.04	0.12	0.16
3000	0.01	0.03	0.05	0.08	0.04	0.04	0.14	0.18
3200	0.02	0.04	0.06	0.09	0.05	0.05	0.16	0.20
3400	0.02	0.04	0.07	0.10	0.05	0.05	0.17	0.23
3600	0.02	0.05	0.07	0.11	0.06	0.06	0.19	0.25
3800	0.02	0.06	0.08	0.12	0.06	0.06	0.22	0.27
4000	0.03	0.06	0.09	0.14	0.07	0.07	0.24	0.30
4200	0.03	0.07	0.10	0.15	0.07	0.07	0.26	0.33
4400	0.03	0.07	0.11	0.16	0.08	0.08	0.28	0.36
4600	0.03	0.08	0.12	0.18	0.09	0.09	0.31	0.39
4800	0.04	0.08	0.13	0.19	0.10	0.10	0.33	0.43
5000	0.04	0.09	0.14	0.21	0.10	0.10	0.36	0.46

**TABLE 14: STATIC RESISTANCE FOR UNIT ACCESSORIES (IWG) - KEU180**

CFM	Electric Heat KW					Supply Air Plenum	Return Air Grill	Hot Water Coil	Steam Coil
	10	16	26	36	72				
4600	0.03	0.08	0.12	0.18	0.23	0.05	0.05	0.31	0.39
4800	0.04	0.08	0.13	0.19	0.25	0.06	0.06	0.33	0.43
5000	0.04	0.09	0.14	0.21	0.27	0.06	0.06	0.36	0.46
5200	0.04	0.10	0.16	0.23	0.29	0.06	0.06	0.38	0.50
5400	0.05	0.10	0.17	0.24	0.31	0.07	0.07	0.41	0.54
5600	0.05	0.11	0.18	0.26	0.34	0.07	0.07	0.44	0.58
5800	0.06	0.11	0.20	0.28	0.37	0.08	0.08	0.47	0.62
6000	0.06	0.12	0.21	0.30	0.40	0.08	0.08	0.50	0.66
6200	0.07	0.13	0.22	0.32	0.43	0.08	0.08	0.53	0.71
6400	0.07	0.13	0.24	0.34	0.47	0.09	0.09	0.56	0.75
6600	0.08	0.14	0.25	0.36	0.51	0.09	0.09	0.59	0.80
6800	0.08	0.15	0.27	0.38	0.55	0.10	0.10	0.62	0.85
7000	0.09	0.15	0.29	0.41	0.59	0.10	0.10	0.66	0.90
7200	0.09	0.16	0.30	0.43	0.64	0.10	0.10	0.69	0.95
7400	0.10	0.17	0.32	0.45	0.68	0.11	0.11	0.73	1.01

**TABLE 15: SUPPLY AIR PLENUM PERFORMANCE DATA**

Model	CFM	Face Velocity (FPM)	Angle of Deflection																	
			0° SPREAD						22-1/2° SPREAD						45° SPREAD					
			Vertical Louvers <sup>1</sup> (Plan View)		Horizontal Louvers <sup>2</sup> (Elevation View)		Vertical Louvers (Plan View)		Horizontal Louvers (Elevation View)		Vertical Louvers (Plan View)		Horizontal Louvers (Elevation View)		Vertical Louvers (Plan View)		Horizontal Louvers (Elevation View)			
			Throw (Feet)		Spread (Feet) <sup>3</sup>		Drop (Feet) <sup>4</sup>		Throw (Feet)		Spread (Feet)		Drop (Feet)		Throw (Feet)		Spread (Feet)		Drop (Feet)	
Min.	Max.	Min.	Max.	Min.	Max.	Min.	Max.	Min.	Max.	Min.	Max.	Min.	Max.	Min.	Max.	Min.	Max.	Min.	Max.	
060	1600	630	38	59	13	20	15	8	27	43	12	19	14	7	21	32	33	48	8	4
	1800	710	43	67	14	22	16	8	30	48	14	22	14	7	23	37	35	56	8	4
	2000	790	48	74	16	25	16	9	34	53	15	24	14	8	25	40	38	60	9	5
	2200	870	52	81	17	27	16	9	37	58	17	26	15	8	29	44	44	66	9	5
	2400	940	57	89	19	30	17	9	41	64	18	29	15	8	30	48	45	72	9	5
090	2400	615	47	74	20	29	19	9	34	53	23	33	17	8	26	39	45	65	9	5
	2700	690	53	83	22	32	20	10	39	59	25	36	18	9	29	45	48	71	10	5
	3000	770	59	92	24	35	21	10	42	66	27	40	19	9	32	50	52	78	10	5
	3300	845	65	101	26	38	21	10	46	73	29	44	19	9	35	55	56	85	10	5
	3600	920	71	110	28	41	22	11	50	79	32	47	20	10	38	60	60	91	11	6
120	3200	820	63	98	25	37	21	10	45	70	29	43	19	9	34	53	54	82	10	5
	3600	920	71	110	28	41	22	11	50	79	32	47	20	10	38	60	60	91	11	6
	4000	1025	78	123	30	45	22	11	56	88	35	52	20	10	42	66	67	102	11	6
	4400	1130	86	135	33	49	23	12	62	97	38	57	21	11	47	73	76	115	12	6
	4800	1230	94	147	35	53	23	12	68	106	41	62	21	11	51	80	85	127	12	6
180	4800	880	84	132	32	48	23	12	61	95	38	56	21	11	46	72	73	112	12	6
	5400	1000	95	149	36	54	24	12	68	107	42	63	22	11	52	81	81	124	12	6
	6000	1110	106	165	39	59	25	13	76	119	46	69	23	12	57	89	90	138	13	7
	6600	1220	116	182	43	65	26	13	84	131	50	76	23	12	63	98	99	152	13	7
	7200	1330	126	199	46	70	27	14	92	143	55	83	24	12	68	107	109	166	14	7

1. Adjusting the vertical louvers will vary the throw, the spread and the drop.
2. Adjusting the horizontal louvers will only vary the drop.
3. The velocity of the air will be 125 ft./min. at the minimum distance and 80 ft./min. at the maximum distance.
4. The velocity of the conditioned air at the bottom of the drop will be 50 ft./min. Drafts will occur if the drop extends into the occupied level of the conditioned space.

**TABLE 16: BLOWER MOTOR AND DRIVE DATA**

MODEL	BLOWER RANGE (RPM)	MOTOR		ADJUSTABLE MOTOR PULLEY				FIXED BLOWER PULLEY				BELT (NOTCHED)		
		HP	FRAME	DESIG-NATION	OUTSIDE DIA. (IN.)	PITCH DIA. (IN.)	BORE (IN.)	DESIG-NATION	OUTSIDE DIA. (IN.)	PITCH DIA. (IN.)	BORE (IN.)	DESIG-NATION	PITCH LENGTH (IN.)	QTY.
060	810/1110	3/4	56	1VL44	3.1-4.1	2.8-3.8	5/8	AL64	6.2	5.8	3/4	A32	33.3	1
090	655/880	1-1/2	56	1VL44	2.1-4.1	2.8-3.8	7/8	AK79	7.9	7.5	1	A36	37.3	1
120	700/950	2	56	1VL44	3.1-4.1	2.8-3.8	7/8	BK80	7.4	7.0	1	A36	37.3	1
180	625/810	3	56	1VM50	3.7-4.7	3.4-4.4	7/8	BK105	9.9	9.5	1	A57	58.3	1

TABLE 17: KEU PHYSICAL DATA

Component	Description	Model			
		060	090	120	180
<b>EVAPORATOR BLOWER<sup>1</sup></b>	Centrifugal Blower (Dia. X Wd. in.)	15 X 15	15 X 15	15 X 15	18 X 18
	Fan Motor HP (Belt Drive)	3/4	1-1/2	2	3
<b>EVAPORATOR COIL</b>	Rows Deep	3	3	3	3
	Finned Length (in.)	30	46	46	54
	Fins per Inch	13	13	13	13
	Face Area (ft. <sup>2</sup> )	5.0	8.6	10.2	12.1
<b>HOT WATER COIL</b>	Rows Deep	2	2	2	2
	Finned Length (in.)	30	46	46	54
	Fins Per Inch	12	12	12	12
	Face Area (ft. <sup>2</sup> )	3.8	5.4	5.4	9.0
	Inlet Connection	1" NPTE	1" NPTE	1" NPTE	1-3/8" O.D
	Outlet Connection	1" NPTE	1" NPTE	1" NPTE	1-3/8" O.D
<b>STEAM COIL</b>	Rows Deep	1	1	1	1
	Finned Length (in.)	30	46	46	54
	Fins Per Inch	8	8	8	8
	Face Area (ft. <sup>2</sup> )	3.8	5.4	5.4	9.0
	Inlet Connection	1-1/2" NPTE	1-1/2" NPTE	1-1/2" NPTE	1-1/2" NPTE
	Outlet Connection	1-1/2" NPTE	1-1/2" NPTE	1-1/2" NPTE	1-1/2" NPTE
<b>AIR FILTERS</b>	Quantity Per Unit (16" X 25" X 1")	2	4	4	0
	Quantity Per Unit (20" X 20" X 1")	0	0	0	6
	Total Face Area (ft. <sup>2</sup> )	5.6	11.1	11.1	16.7
<b>HOLDING CHARGE</b>	Refrigerant 22 (lbs./oz.)	0/7	0/7	0/10	0/0

1. Refer to Blower Motor and Drive Data table for additional blower and drive information.  
All of these 1750 RPM motors are solid base, 56 frame with 1.15 service factor, inherent protection and permanently lubricated ball bearings.

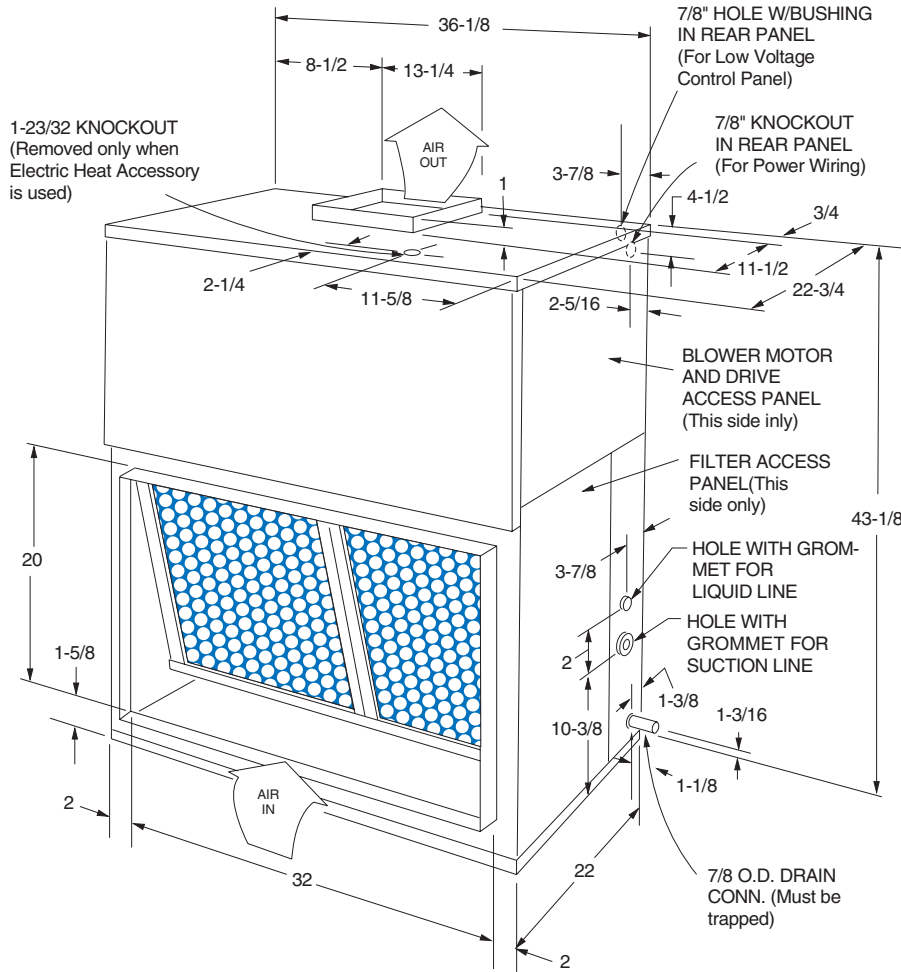

All dimensions are in inches. They are subject to change without notice. Certified dimensions will be provided upon request.

**FIGURE 5 - UNIT DIMENSIONS KEU060**

**ACCESSORIES**

- ELECTRIC HEATER - Add 13" to unit height when used.
- SUPPLY AIR PLENUM - Add 24-1/4" to unit height when used.
- BASE - Add 20" to unit height when used.

1. Overall dimensions of the unit will vary if an electric heater, a supply air plenum or a base is used.
2. This dimension is required for removal of the coil. Only 26" is required for normal service.
3. Although no clearance is required for service and operation, some clearance may be required for routing the power and control wiring.
4. Allow enough clearance to trap the condensate drain line.

**TABLE 18: UNIT CLEARANCES KEU060**

MINIMUM CLEARANCES	060
Side with RETURN AIR opening	24"
Side with SUPPLY AIR opening <sup>1</sup>	24"
Side with PIPING CONNECTIONS <sup>2</sup>	36"
Side opposite with PIPING CONNECTIONS	12"
Side with access for both POWER & CONTROL WIRING <sup>3</sup> .	-
Bottom <sup>4</sup>	-



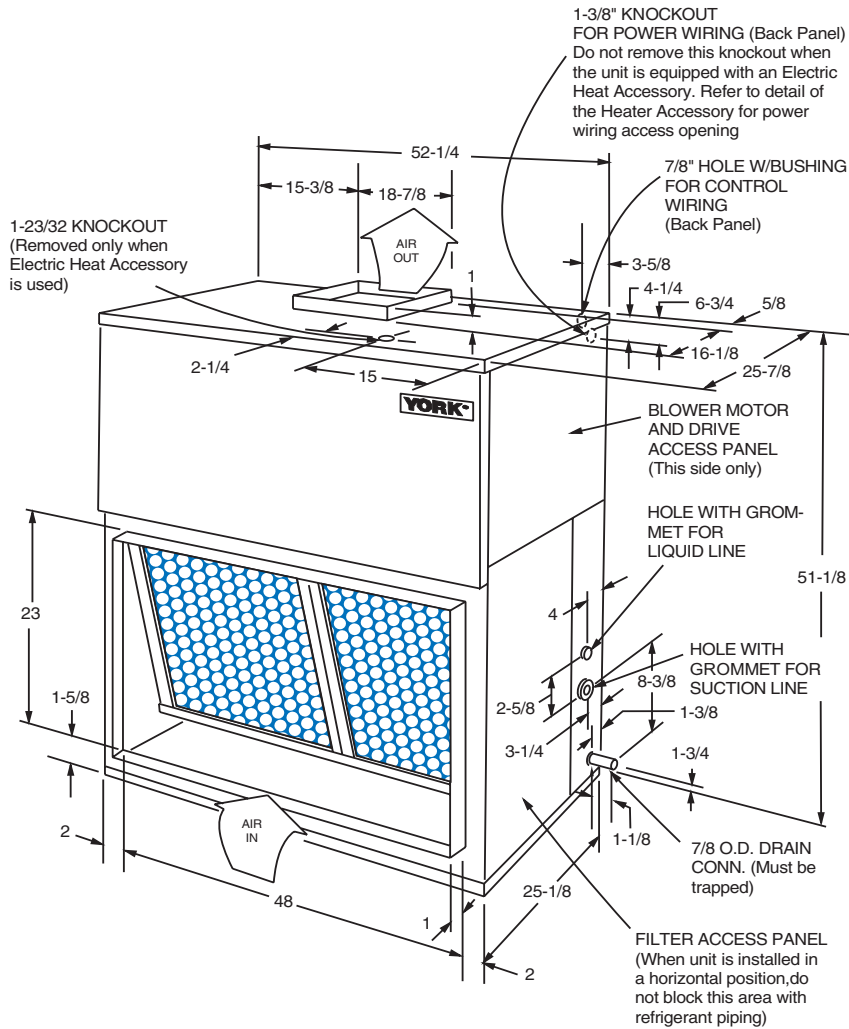

All dimensions are in inches. They are subject to change without notice. Certified dimensions will be provided upon request.

**FIGURE 6 - UNIT DIMENSIONS KEU090 & 120**

**ACCESSORIES**

- ELECTRIC HEATER - Add 14-1/4" to unit height when used.
- SUPPLY AIR PLENUM - Add 27-1/2" to unit height when used.
- BASE - Add 20" to unit height when used.

1. Overall dimensions of the unit will vary if an electric heater, a supply air plenum or a base is used.
2. This dimension is required for removal of the coil. Only 26" is required for normal service.
3. Although no clearance is required for service and operation, some clearance may be required for routing the power and control wiring.
4. Allow enough clearance to trap the condensate drain line.

**TABLE 19: UNIT CLEARANCES KEU090 & 120**

MINIMUM CLEARANCES	090-120
Side with RETURN AIR opening	24"
Side with SUPPLY AIR opening <sup>1</sup>	24"
Side with PIPING CONNECTIONS <sup>2</sup>	36"
Side opposite with PIPING CONNECTIONS	12"
Side with access for both POWER & CONTROL WIRING <sup>3</sup> .	-
Bottom <sup>4</sup>	-

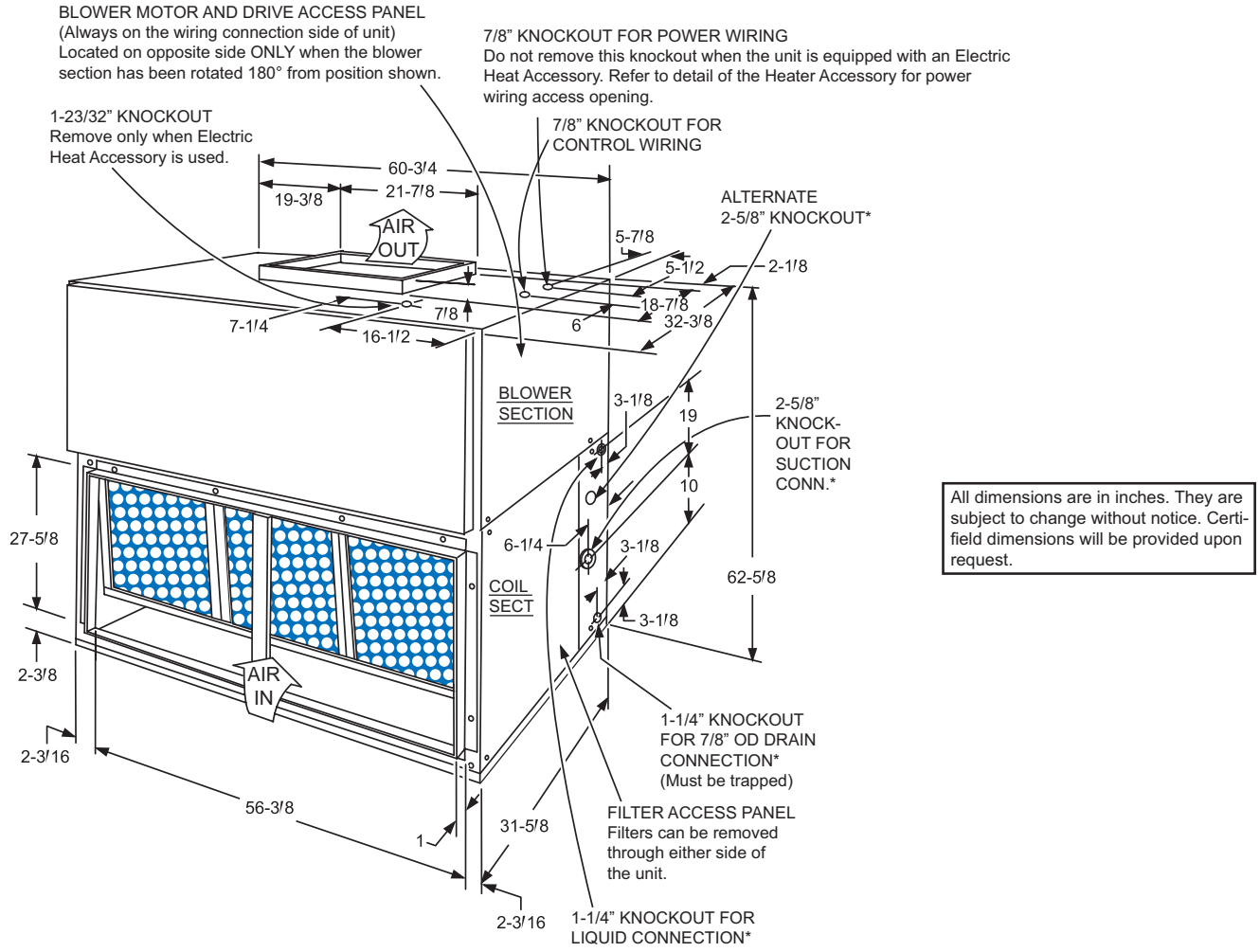

All dimensions are in inches. They are subject to change without notice. Certified dimensions will be provided upon request.

\*Refer to INSTALLING REFRIGERANT MAINS in installation instruction when piping through the opposite side of the unit.

**FIGURE 7 - UNIT DIMENSIONS KEU180**

**ACCESSORIES**

- **ELECTRIC HEATER** - Add 14-1/4" to unit height when using 10, 16, 26, or 36 KW heater
- **SUPPLY AIR PLENUM** - Add 27" to unit height when used.
- **BASE** - Add 24" to unit height when used.
- **HOT WATER OR STEAM COIL** - Add 6" to unit depth when used.

**TABLE 20: UNIT CLEARANCES KEU180**

MINIMUM CLEARANCES	180
Side Air with RETURN AIR opening	24"
Side with SUPPLY AIR opening <sup>1</sup>	24"
Side with PIPING CONNECTIONS <sup>2</sup>	61"
Side opposite PIPING CONNECTIONS <sup>3</sup>	26"
Bottom <sup>4</sup>	-

1. Overall dimension of the unit will vary if an electric heater, a supply air plenum or a base is used.
2. This dimension is required for removal of the DX coil. Only 26" is required for normal servicing.
3. If the coil has to be removed, this dimension is required to loosen screws that secure the coil to the unit frame. This dimension will also be required for blower motor access if the piping connections are made on the opposite side of the unit.
4. Allow enough clearance to trap the condensate drain lines.

**SUPPLY AIR PLENUM**

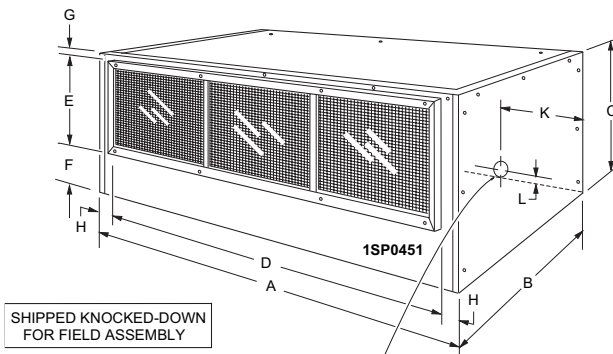

**060, 090, 120 - KNOCKOUT FOR POWER WIRING**

**WITH ELECTRIC HEAT** - Remove this 2-1/2" knockout from the rear panel of the plenum. Route the power wiring conduit through this opening and connect it to the field-supplied fitting on the electric heat accessory. Connect the power wiring to the fuse block in the heater control box.

Install the control wiring per basic unit Installation Manual. **DO NOT** route any field control wiring through the plenum.

Electric Heaters are NOT CSA approved for installation within a supply air plenum.

**WITHOUT ELECTRIC HEAT** - Install the power and the control wiring per basic unit Installation Manual. **DO NOT** route any wiring through the plenum and **DO NOT** remove this knockout.

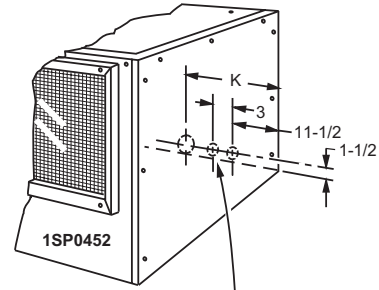

**180 - KNOCKOUTS FOR POWER & CONTROL WIRING**

**WITH ELECTRIC HEAT** - Remove this 2-1/2" knockout and one of the 7/8" knockouts from the rear panel of the plenum. Remove the 1-23/32" knockout and one of the 7/8" knockouts from the top panel of the basic unit. Install a 1/2" squeeze connector in both of the 7/8" openings.

Route the power wiring conduit through the 2-1/2" opening and connect it to the field-supplied fitting on the electric heat accessory. Connect the power wiring to the fuse block in the heater control box.

Route the control wires through the 7/8" openings and connect them to the terminals on block TB1. Secure them with the 1/2" squeeze connectors.

Electric Heaters are NOT CSA approved for installation within a supply air plenum.

**WITHOUT ELECTRIC HEAT** - Remove both 7/8" knockouts from the rear panel of the plenum and both 7/8" knockouts from the top panel of the basic unit. Install a 1/2" squeeze connector in one of the plenum openings and both of the unit openings. Install a 1/2" conduit fitting in the other opening of the plenum.

Connect the power wiring conduit to the fitting on the plenum. Route the power wiring through the conduit, one of the squeeze connectors on the unit, and the field-supplied squeeze connector on the blower motor contactor box. Connect the power wiring to the blower motor contactor.

Route the control wires through the remaining plenum and unit openings and connect them to the terminals on block TB1. Secure them with the 1/2" squeeze connectors.

Plenum Model	Unit Model	Plenum Dimensions (inches)									
		A	B	C	D	E	F	G	H	K	L
1SP0450	060	36	25-1/2	34-2/8	31-3/4	15-3/4	7-5/8	7/8	2-1/8	11-1/4	2
1SP0451	090 120	52-1/8	28-1/4	27-1/2	49-3/8	17-7/8	8-3/4	7/8	1-1/8	15-1/4	1-3/4
1SP0452	180	60-3/4	31	27	55-3/4	19-7/8	6-1/8	1	2-1/2	19-1/2	1-3/4

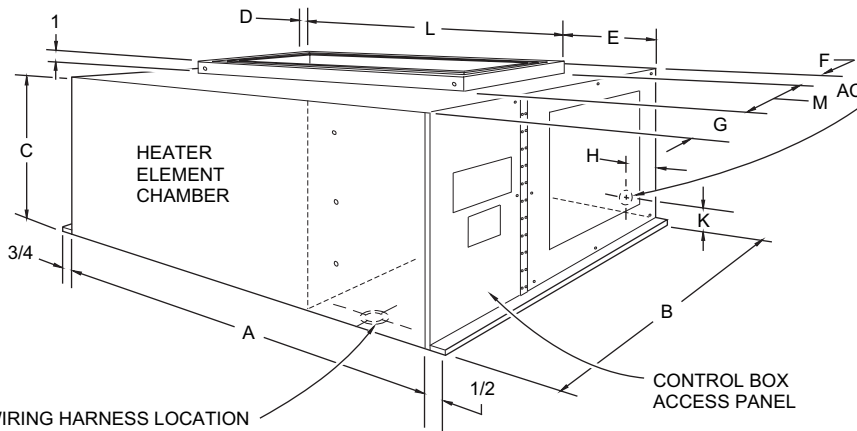

**WIRING HARNESS LOCATION**  
This opening in the bottom of the heater control box is used for the wiring harness that connects the heater accessory to the basic unit. It is provided with a squeeze connector for securing the wiring harness, and its location corresponds to the location of the 1-23/32" knockout in the top panel of the basic unit.

**10KW THRU 36KW** - Add a 1-1/4" conduit fitting to the 1-23/32" hole for wire sizes up through #1 AWG. Remove the knockout ring and add a 1-1/2" conduit fitting to the 1-31/32" hole for wire sizes up through #0 AWG.

**72KW THRU 36KW** - Add a 1-1/4" conduit fitting to the 1-23/32" hole for wire sizes up through #1 AWG. Remove the knockout ring and add a 2" conduit fitting to the 2-1/2" hole for wire sizes up through #0000 AWG.

**FIGURE 8 - ACCESSORY DIMENSIONS**

**TABLE 21: ELECTRIC HEATER DIMENSIONS KEU060, 090, 120 & 180**

Heater Model	Nom. kW	Unit Model	Heater Dimensions (inches)										
			A	B	C	D	E	F	G	H	K	L	M
2HT04501025 <sup>1</sup>	10	060	25-1/8	22-1/2	13	7/8	4	1/2	5-1/4	1-11/16	1-3/4	20-1/8	16-7/8
2HT04501625 <sup>1</sup>	16												
2HT04502625 <sup>1</sup>	26												
2HS04501025, 46, 58	10	090	27-1/4	25-1/4	14-1/4	1	4	1/2	5-1/2	1-1/2	1-1/2	22-1/4	19-1/4
2HS04501625, 46, 58	16	120											
2HS04502625, 46, 58	26	180											
2HS04503625, 46, 58	36												
2HS04507225, 46, 58	72	180	29-7/8	26-3/8	21-3/4	2-3/8	5-1/4	3/4	6-3/8	2-1/4	2-1/2	22-1/4	19-1/4

1. The 2HT heaters are not CSA approved for 060 units mounted horizontally.

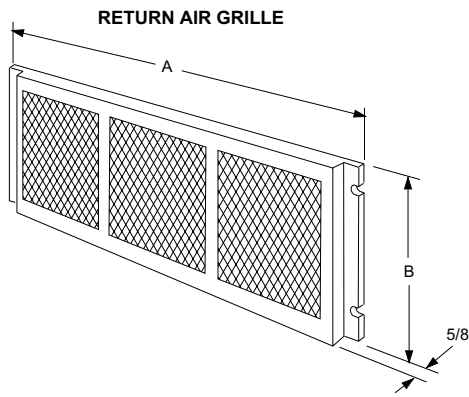

**FIGURE 9 - RETURN AIR GRILLE**

Grill Model	Unit Model	Grill Dimensions (Inches)	
		A	B
1RG0450	060	36	22
1RG0451	090 120	52	25
1RG0452	180	60-3/4	31

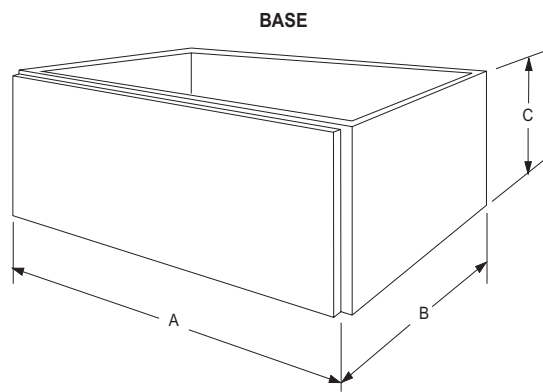

**FIGURE 10 - BASE ACCESSORY**

Grill Model	Unit Model	Grill Dimensions (Inches)		
		A	B	C
1BS0450	060	36	22	20
1BS0451	090 120	52	25-1/8	20
1BS0452	180	60-3/4	31-5/8	24

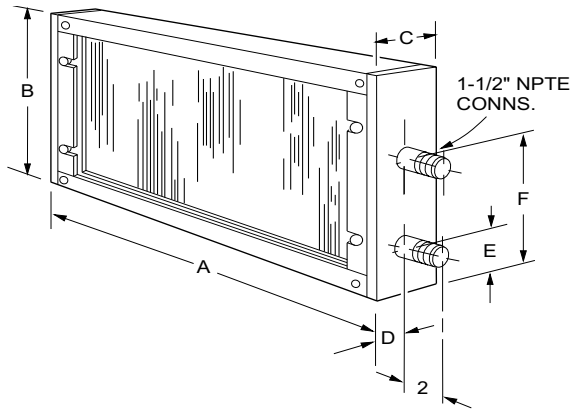

FIGURE 11 - STEAM COIL

Coil Model	Unit Model	Steam Coil Dimensions (inches)					
		A	B	C	D	E	F
1NF0450 <sup>1</sup>	060	36	21-7/8	5	2-1/2	2-5/8	10-5/8
1NF0451 <sup>1</sup>	090	52	25	5	2-1/2	2-5/8	13-5/8
1NF0451 <sup>1</sup>	120	52	25	5	2-1/2	2-5/8	13-5/8
1NF0452 <sup>2</sup>	180	60-3/4	32-1/4	6	3-5/16	3-1/2	17-1/2

1. Installs over the return air opening of the unit-before the filters.
2. Installs between the coil and blower section of the unit.

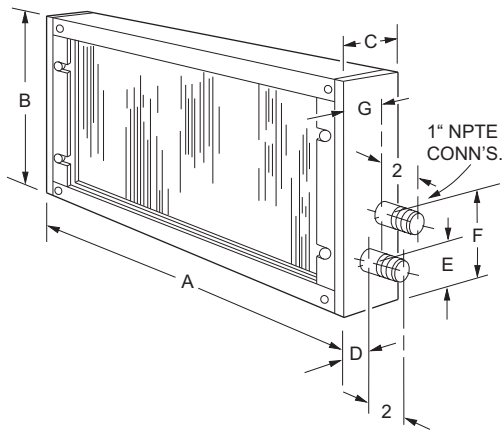

FIGURE 12 - HOT WATER COIL

Coil Model	Unit Model	Hot Water Coil Dimensions (inches)							
		A	B	C	D	E	F	G	H
1HW0450 <sup>1</sup>	060	36	21-7/8	5	1-11/16	2-3/4	6-1/4	3-3/8	1" NPTE
1HW0451 <sup>1</sup>	090	52	25	5	1-11/16	2-3/4	5-7/8	3-3/8	1" NPTE
1HW0451 <sup>1</sup>	120	52	25	5	1-11/16	2-3/4	5-7/8	3-3/8	1" NPTE
1HW0452 <sup>2</sup>	180	60-3/4	32-1/4	6	2-5/32	3-5/16	6-9/16	3-27/32	1-3/8 NPTE

1. Installs over the return air opening of the unit-before the filters.
2. Installs between the coil and blower section of the unit.

TABLE 22: KEU ELECTRICAL DATA

Model (TONS)	Power Supply Voltage	Indoor Motor FLA	Heater Model Number	Nominal Heater KW	Applied Heater KW	Electric Heat Amps	Min. Circuit Ampacity (AMPS)	Max. Fuse <sup>1</sup> / HACR Breaker <sup>2</sup> (AMPS)
060 <sup>3</sup> (5)	208	7.6	None	--	--	--	9.5	15
			2HT04501025	10	7.5	20.8	35.6	40
			2HT04501625	16	12.0	33.4	51.2	60
			2HT04502625	26	19.5	54.2	77.3	80
	240	6.9	None	--	--	--	8.6	15
			2HT04501025	10	10.0	24.1	38.7	40
			2HT04501625	16	16.0	38.5	56.7	60
			2HT04502625	26	26.0	62.5	86.8	90
090 (7.5)	208	6.6	None	--	--	--	8.3	15
			2HS04501025	10	7.5	20.8	34.3	35
			2HS04501625	16	12.0	33.4	49.9	50
			2HS04502625	26	19.5	54.2	76.0	80
			2HS04503625	36	27.0	75.1	102.1	110
	240	6.0	None	--	--	--	7.5	15
			2HS04501025	10	10.0	24.1	37.6	40
			2HS04501625	16	16.0	38.5	55.6	60
			2HS04502625	26	26.0	62.5	85.7	90
			2HS04503625	36	36.0	86.6	115.8	125
	460	3.0	None	--	--	--	3.8	15
			2HS04501046	10	10.0	12.0	18.8	20
			2HS04501646	16	16.0	19.2	27.8	30
			2HS04502646	26	26.0	31.3	42.8	45
			2HS04503646	36	36.0	43.3	57.9	60
	575	2.4	None	--	--	--	3.0	15
			2HS04501058	10	10.0	9.6	15.0	20
			2HS04501658	16	16.0	15.4	22.2	25
			2HS04502658	26	26.0	25.0	34.3	35
			2HS04503658	36	36.0	34.6	46.3	50
120 (10)	208	7.5	None	--	--	--	9.4	15
			2HS04501025	10	7.5	20.8	35.4	40
			2HS04501625	16	12.0	33.4	51.1	60
			2HS04502625	26	19.5	54.2	77.1	80
			2HS04503625	36	27.0	75.1	103.2	110
	240	6.8	None	--	--	--	8.5	15
			2HS04501025	10	10.0	24.1	38.6	40
			2HS04501625	16	16.0	38.5	56.6	60
			2HS04502625	26	26.0	62.5	86.7	90
			2HS04503625	36	36.0	86.6	116.8	125
	460	3.4	None	--	--	--	4.3	15
			2HS04501046	10	10.0	12.0	19.3	20
			2HS04501646	16	16.0	19.2	28.3	30
			2HS04502646	26	26.0	31.3	43.3	45
			2HS04503646	36	36.0	43.3	58.4	60
	575	2.7	None	--	--	--	3.4	15
			2HS04501058	10	10.0	9.6	15.4	20
			2HS04501658	16	16.0	15.4	22.6	25
			2HS04502658	26	26.0	25.0	34.6	35
			2HS04503658	36	36.0	34.6	46.7	50

**TABLE 22: KEU ELECTRICAL DATA (CONTINUED)**

Model (TONS)	Power Supply Voltage	Indoor Motor FLA	Heater Model Number	Nominal Heater KW	Applied Heater KW	Electric Heat Amps	Min. Circuit Ampacity (AMPS)	Max. Fuse <sup>1</sup> / HACR Breaker <sup>2</sup> (AMPS)
<b>180 (15)</b>	208	10.6	None	--	--	--	13.3	20
			2HS04501025	10	7.5	20.8	39.3	40
			2HS04501625	16	12.0	33.4	54.9	60
			2HS04502625	26	19.5	54.2	81.0	90
			2HS04503625	36	27.0	75.1	107.1	110
			2HS04507225	72	54.1	150.1	200.9	225
	240	9.6	None	--	--	--	12.0	15
			2HS04501025	10	10.0	24.1	42.1	45
			2HS04501625	16	16.0	38.5	60.1	70
			2HS04502625	26	26.0	62.5	90.2	100
			2HS04503625	36	36.0	86.6	120.3	125
			2HS04507225	72	72.0	173.2	228.5	250
	460	4.8	None	--	--	--	6.0	15
			2HS04501046	10	10.0	12.0	21.0	25
			2HS04501646	16	16.0	19.2	30.1	35
			2HS04502646	26	26.0	31.3	45.1	50
			2HS04503646	36	36.0	43.3	60.1	70
			2HS04507246	72	72.0	86.6	114.3	125
	575	3.9	None	--	--	--	4.9	15
			2HS04501058	10	10.0	9.6	16.9	20
			2HS04501658	16	16.0	15.4	24.1	25
			2HS04502658	26	26.0	25.0	36.1	40
			2HS04503658	36	36.0	34.6	48.2	50
			2HS04507258	72	72.0	69.3	91.5	100

1. Dual element time delay.
2. HACR type per NEC.
3. The K\*EU060 indoor motor is single phase. The electrical heaters MUST be supplied with 3-phase voltage only.

Subject to change without notice. Printed in U.S.A.  
Copyright © by Unitary Products Group 2007. All rights reserved.

246668-YTG-C-0307  
Supersedes: 246668-YTG-B-0906

---

<b>Unitary</b>	<b>5005</b>	<b>Norman</b>
<b>Products</b>	<b>York</b>	<b>OK</b>
<b>Group</b>	<b>Drive</b>	<b>73069</b>