

Climate Panel[®] Heating System

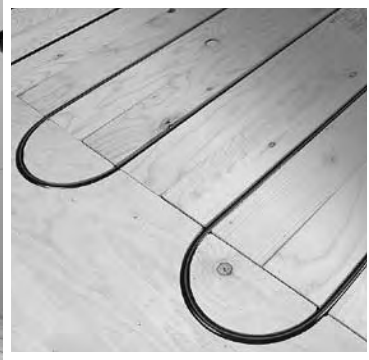

Installation Manual

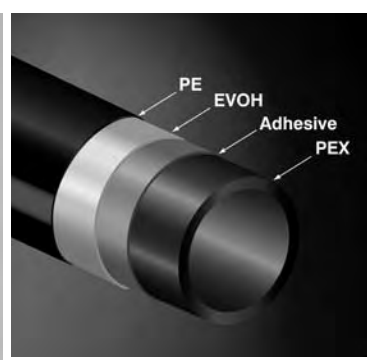

February 2009

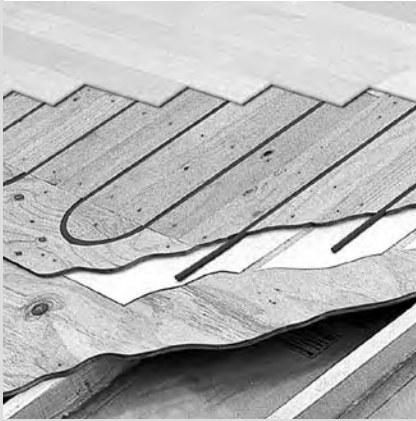

Disclaimer: Systems should be protected from freezing at all times. Proper insulation or glycol mixture may be needed in system if not used for an extended period of the heating season.

Working with Viega is the perfect solution.

Viega researches, develops and produces complete system solutions for contractors in the technical building installation business. The components are produced at our plants or are supplied exclusively by the finest quality manufacturers. Each of our systems is developed in-house and tested under stringent quality control conditions to guarantee safety and efficient operation.

An international company with a national commitment.

Viega recognizes that many of the advances in our industry have their beginnings in Europe. However, that does not mean North America deserves anything less.

Therefore, we have been the pioneer in combining technology from both sides of the Atlantic into the very best plumbing and heating systems for our customers.

Our goal is to remain in the forefront of the plumbing and heating industry well into the new century, and with our advanced products and a determination to remain the quality leader, we are convinced this accomplishment is well within our reach.

Welcome

By choosing to install a Climate Panel System, you have joined the ranks of heating system installers across the country who believe there is no substitute for quality.

Viega has a history of bringing high quality and innovative technology to the hydronic marketplace in the United States.

It is the business of our engineers to research and develop complete systems that provide you the most effective and easy-to-use products available.

In the following pages, you will be guided through the system design, layout, installation and start-up of our Climate Panel System.

We look forward to sharing our history in the making with you.

Call 877-843-4262 for your local District Manager and wholesale location.

CONTENTS

| | | | |
|---|-------|---|-------|
| 1 System Advantages | | Appendix A | |
| 1.1 Application Benefits | 4 | Making a Press Connection | 34 |
| 2 System Design | | Appendix B | |
| 2.1 Creating a Climate Panel Material List | 5 | Compression Coupling 5/16" Product Instructions | 35 |
| 2.2 Heat Loss Calculations for Floor Heating Systems using Radiant Wizard™ | 6 | Appendix C | |
| 2.3 Calculating the Supply Water Temperature | 6 | Making a Compression Connection | 36 |
| 2.4 Calculating the Floor Surface Temperature | 7 | Appendix D | |
| 2.5 Calculating the Pressure Drop | 8 | Tool List | 37 |
| 2.6 Selecting the Pump | 9 | Appendix E | |
| 2.7 Typical Cross Sections | 15-18 | R-Value Table Floor Coverings | 38 |
| 3 Climate Panel Installation | | Appendix F | |
| 3.1 Layout Planning | 14 | Supply Water Temperature/BTU Output Charts | 39-40 |
| 3.2 Panel Installation: Step 1 | 15 | Appendix G | |
| Panel Installation: Step 2 | 16 | Making a Material List | 41 |
| Panel Installation: Step 3 | 17 | | |
| Panel Installation: Step 4 | 18 | | |
| Panel Installation: Step 5 | 19 | | |
| Panel Installation: Step 6 | 20 | | |
| Panel Installation: Step 7 | 21 | | |
| 3.3 Assembled Climate Panel Installation | 22 | | |
| 3.4 Tubing Installation | 23 | | |
| 4 Piping and Controls Installation | | | |
| 4.1 Mixing Station/Injection Station and Manifolds | 24 | | |
| 4.2 Single Temperature Radiant System | 25 | | |
| Single Temperature Radiant System with Boiler Modulation and Optional DHW Control | 26 | | |
| Multiple Temperature Radiant System with Boiler Modulation | 27 | | |
| 4.3 Zone Wiring | 28 | | |
| 5 System Start-up | | | |
| 5.1 Station and Actuator Installation | 29 | | |
| 5.2 Purging and Pressure Testing the System | 30 | | |
| 5.3 Adjusting the High-Limit Kit | 31 | | |
| 5.4 Initial Balancing | 32 | | |
| 6 Finish Flooring | | | |
| 6.1 Choosing a Finished Floor | 33 | | |

1. SYSTEM ADVANTAGES

1.1 Application Benefits

- Fast installation
- No logistic problems associated with poured concrete (time for curing)
- Tubing is visible during nailing of wood finish flooring
- Low thermal mass means fast, dynamic response and minimal flywheel effect
- Compatible with hardwood flooring

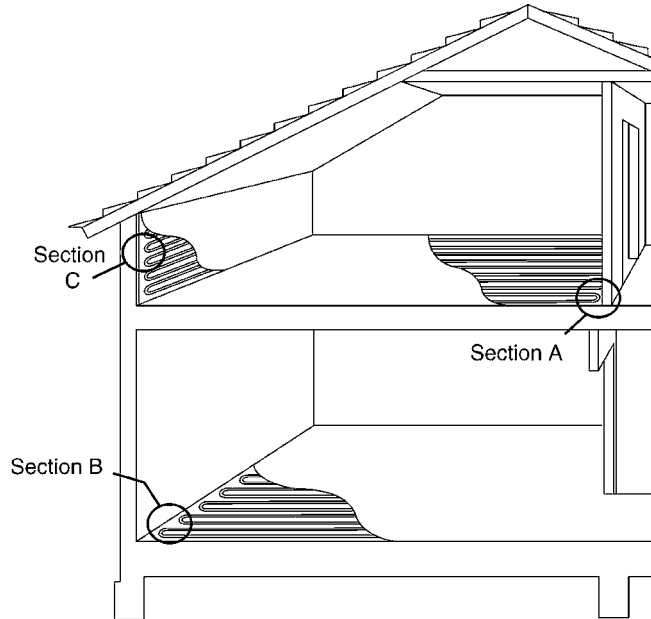

Wood Subfloor:

Ideal for wood frame construction, Climate Panels add no moisture to the building structure!

Designers

- No weight buildup reduces structural concerns.

Existing Concrete:

A Climate Panel System on top of an existing concrete floor is a simple retrofit solution.

Contractors

- Contractor has complete control over a Climate Panel System installation. Tubing is visible during finish floor installation to prevent damage.

In the Walls:

With Climate Panels there is a solution to everything. There are very few limits to wall heating.

- Immediately increases the comfort and value of the building.
- Increases heated surface area for high heat loss rooms.

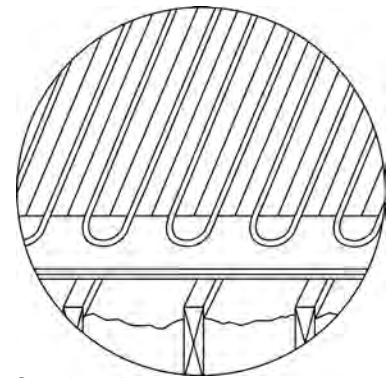

Section A

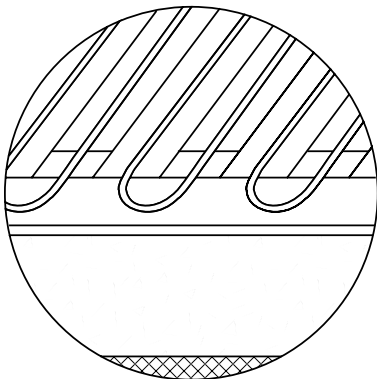

Section B

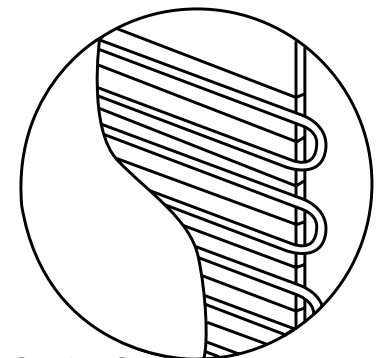

Section C

2. SYSTEM DESIGN

2.1 Creating a Climate Panel Material List

- Calculate the net heated area.
- Use this chart to make an initial material list for the net area to be heated.

Note: This estimation does not include controls. For complete worksheet see Appendix G.

Equation:
 Net Heated Area x Multiplier =
 Estimated amount

| Material | Net Heated Area (ft.) | Multiplier | Estimated Amount |
|----------------------|-----------------------|------------|------------------|
| 7" Panels | | 0.4 | |
| 7" ACPs | | 0.07 | |
| 10" Panels* | | 0.3 | |
| 10" ACPs* | | 0.05 | |
| U-Turns | | 0.04 | |
| Tubing (7" Spacing) | | 1.9 | |
| Tubing (10" Spacing) | | 1.4 | |
| Groove Tube | | 0.02 | |
| Screws | | 4.0 | |
| Staples | | 5.4 | |

*10" used in low heat loss areas.

Use this room accompanied with the chart to practice estimating.

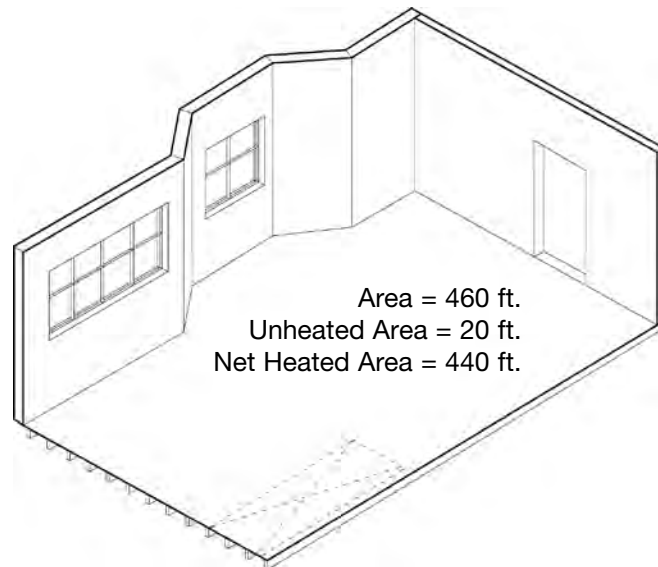

Solutions:

Remember this chart is only for estimating. The number of circuits in the area will be covered in section 3.1 of the Layout Planning. Installer's preference determines choice of staples or screws.

| Material | Net Heated Area (ft.) | Multiplier | Estimated Amount |
|---------------------|-----------------------|------------|------------------|
| 7" Panels | 440 | 0.04 | 176 |
| 7" ACPs | 440 | 0.07 | 31 |
| U-Turns | 440 | 0.04 | 18 |
| Tubing (7" Spacing) | 440 | 1.9 | 836 |
| Groove Tube | 440 | 0.02 | 9 |
| Screws | 440 | 4.0 | 1,760 |
| Staples | 440 | 5.4 | 2,376 |

Note: 10" was not used in solution set.

2.2 Heat Loss Calculations for Floor Heating Systems using Radiant Wizard®

The easy-to-use Radiant Wizard program will help calculate the heat loss of any residential building. Based on ASHRAE formulas, the Radiant Wizard will also perform a full, multi-temperature, room by room, detailed design report while calculating a materials list and price for your system. A step-by-step user manual is provided with

the program to help you with the process. Also, available in the program is a full list of all Viega ProRadiant and PureFlow products, product instructions, specification sheets, manuals and catalogs. Once Radiant Wizard is installed on your computer, updating to the latest version is quick and easily accomplished online. Contact your local Viega District Manager to receive a copy of the Radiant Wizard program.

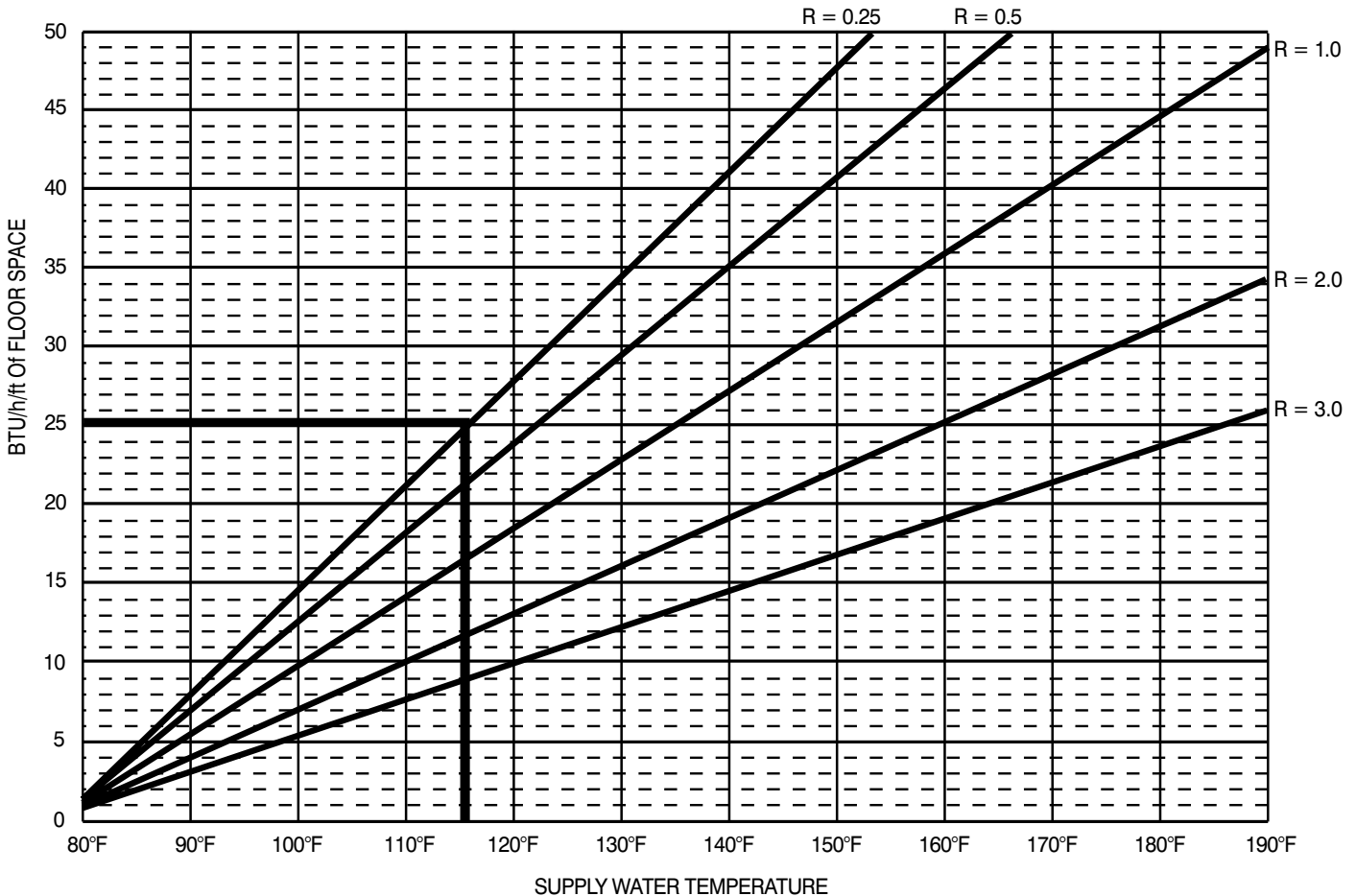
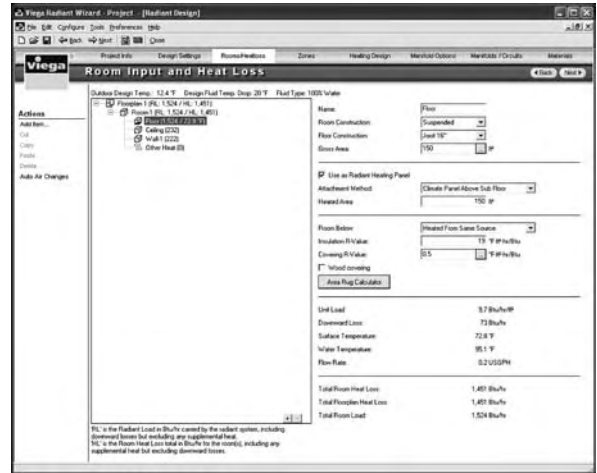

2.3 Calculating the Supply Water Temperature

1. Locate desired BTU output (from Radiant Wizard) on left vertical axis.

2. Follow to the right until you reach the selected total R-value curve.

3. Then move down to the horizontal axis and read the supply water temperature.

Example:

Output needed: 25 BTU/h/ft.²

Finish floor R-value: .25

Supply water temperature: 117°F

(For additional Climate Panel BTU output charts, refer to Appendix F)

2.4 Calculating the Floor Surface Temperature

This chart shows the relation between room temperature and floor surface temperature for floor heating systems.

The relationship between BTU output and floor surface temperature plays an important role in certain finished floor applications (See page 33 for more information on finished flooring.)

Viega recommends that the floor surface temperature should not exceed 85°F because of potential damage to hardwood flooring. Also, at this temperature, the floor will begin to feel hot to the touch rather than comfortable.

In rooms that require a BTU output causing the floor surface temperature to exceed 85°F, wall heat or some kind of supplemental heat will need to be added.

Procedure:

1. Locate desired output (from Radiant Wizard or other source) on left vertical axis.
2. Follow to the right until you reach the curve.
3. Then move down to the horizontal axis and read the ΔT between the room temperature and the floor surface temperature.
4. Add the room temperature and the ΔT to get the floor surface temperature.

Example:

Output needed: 25 BTU/h/ft.²

Room temperature: 68°F

Temperature ΔT
(from chart): ~ 12°F

Floor surface temperature:
 $68^\circ\text{F} + 12^\circ\text{F} = 80^\circ\text{F}$

The floor surface temperature will be 80°F with 25 BTU/h/ft.² output and 68°F room temperature.

Floor Surface Temperature Chart

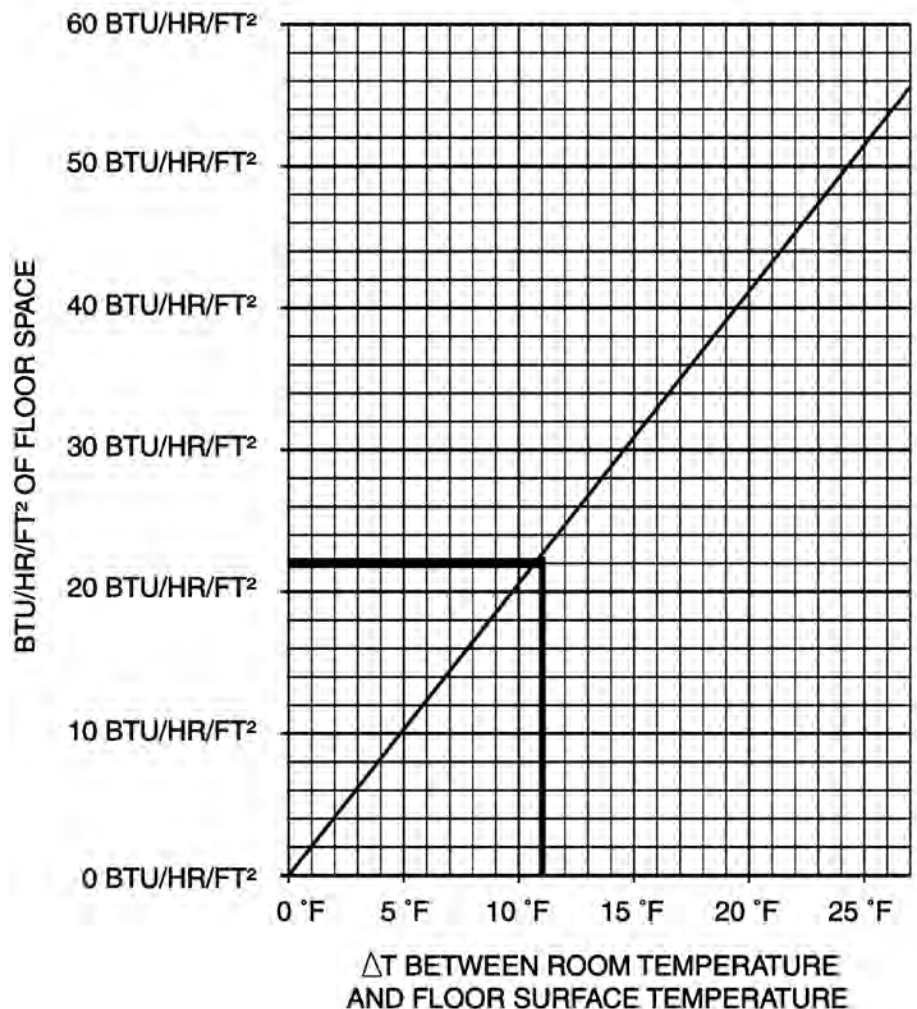

2.5 Calculating the Pressure Drop

In order to select the correct pump size for the system, the pressure drop must be calculated. Use the chart below to calculate the pressure drop.

Procedure:

1. Locate desired flow rate for one circuit on the left vertical axis (receive circuit flow rate from the Radiant Wizard program).
2. Follow to the right until you reach the selected tubing size.
3. Then move down to the horizontal axis and read the pressure drop in feet of head per foot of tubing.
4. Multiply pressure drop per foot by length of longest circuit.

| ViegaPex Barrier Tubing Data Table | | | |
|------------------------------------|------------------------|-----------------------|---------------------|
| Nominal Size (in.) | Outside Diameter (in.) | Inside Diameter (in.) | Water Content (in.) |
| *5/16 | 0.430 | 0.292 | 0.004 |
| 3/8 | 0.500 | 0.350 | 0.005 |
| 1/2 | 0.625 | 0.475 | 0.009 |
| 5/8 | 0.750 | 0.574 | 0.014 |
| 3/4 | 0.875 | 0.671 | 0.018 |
| 1 | 1.125 | 0.862 | 0.030 |
| 1-1/4 | 1.375 | 1.053 | 0.045 |
| 1-1/2 | 1.625 | 1.243 | 0.063 |

*5/16" used in Climate Panel installation.

Example:

GPM through 5/16" ViegaPEX Barrier: 0.3 GPM

Pressure drop per foot: ~ .05 ft. of head/ft.

Total pressure drop: .05 x 250 total ft. = 12.5 ft. of head

Pressure Drop Chart

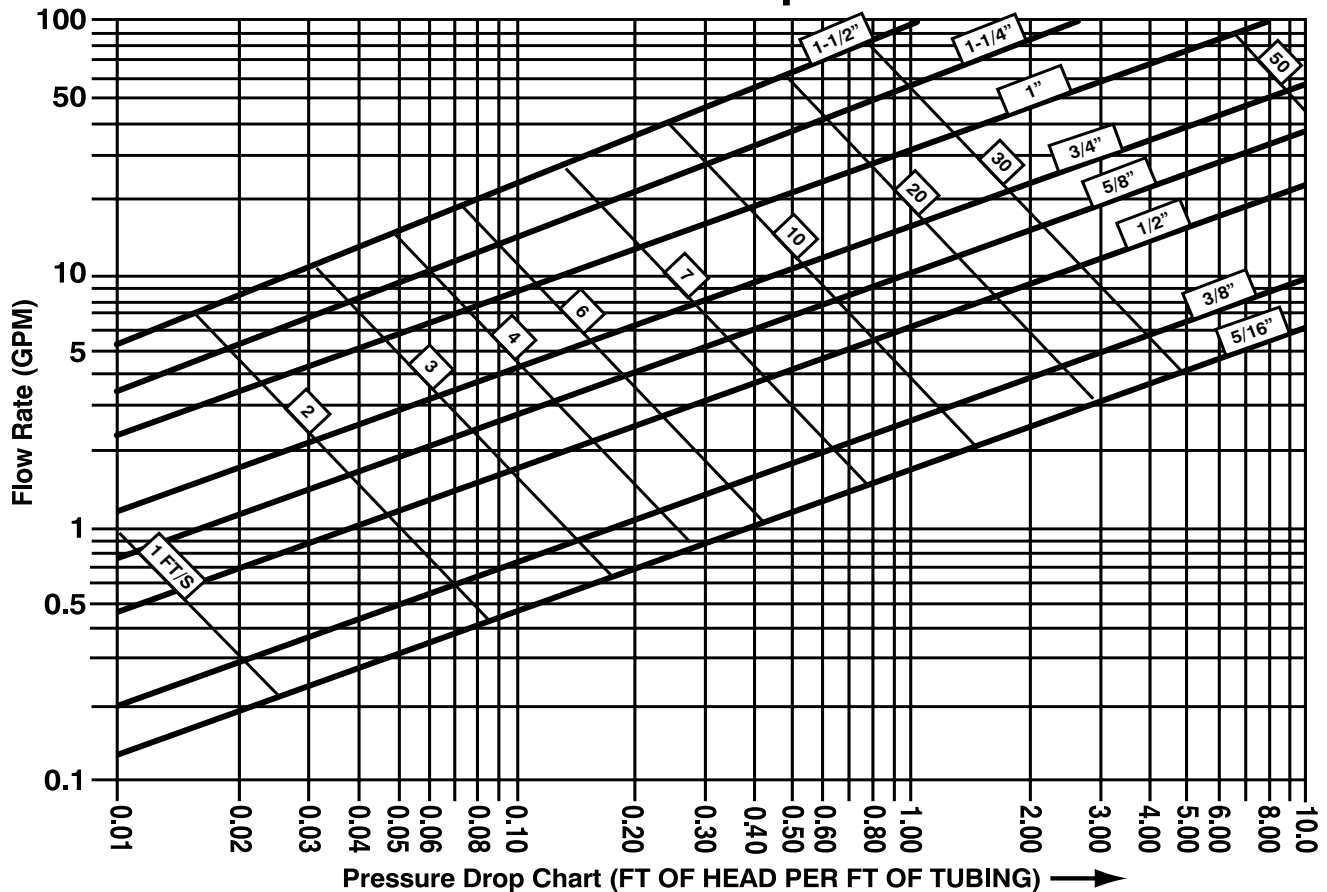

2.6 Selecting a Circulator Pump

The pump must have a capacity equal to the system flow rate and a head equal to the system pressure loss. These two system characteristics are the primary ones in selecting a pump. Flow rates come from the Radiant Wizard program.

Pressure drop comes from section 2.5 (Calculating the Pressure Drop) or from the Radiant Wizard program. Remember that for pressure drop, use the highest pressure drop of all the circuits fed by their circulator. If the circulator can overcome that pressure drop, then it can overcome all the others.

Procedure

1. Locate the pressure drop on the left vertical axis.
2. Locate the total system flow rate on the bottom horizontal axis.
3. Follow to the intersection of both variables.
4. Select the pump with a curve higher than this point.

Example

Total GPM through 5/16" ViegaPEX Barrier:
2 gpm

Longest circuit pressure drop:
12 ft of head

Pump selected:
Low Head Pump, Medium Speed

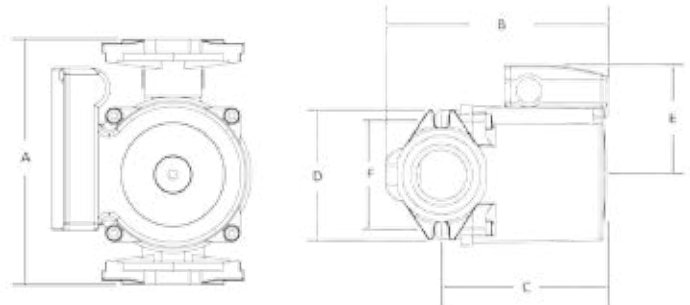

| Stock Code | A | B | C | D | E | F |
|------------|--------|--------|--------|---------|---------|---------|
| 12126 | 6-1/2" | 5-1/4" | 4" | 4-3/16" | 3" | 3-5/32" |
| 12127 | 6-1/2" | 6" | 4-7/8" | 3-1/2" | 3-7/16" | 3-5/32" |

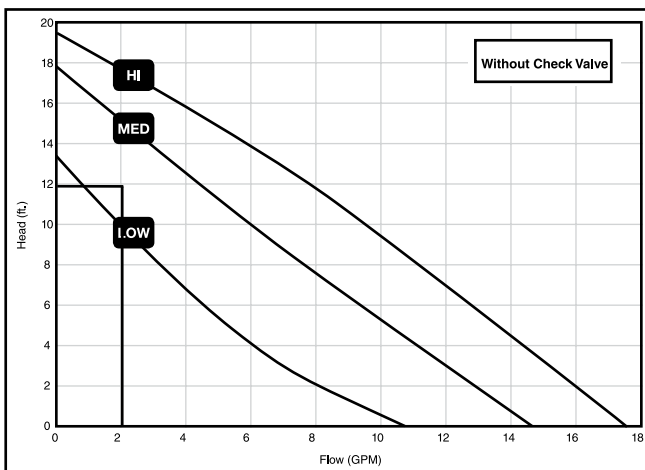

| Stock Code | Speed | Amps | Watts | HP |
|------------|-------|------|-------|------|
| 12126 | HI | 0.75 | 87 | 1/25 |
| | MED | 0.66 | 80 | 1/25 |
| | LOW | 0.55 | 60 | 1/25 |

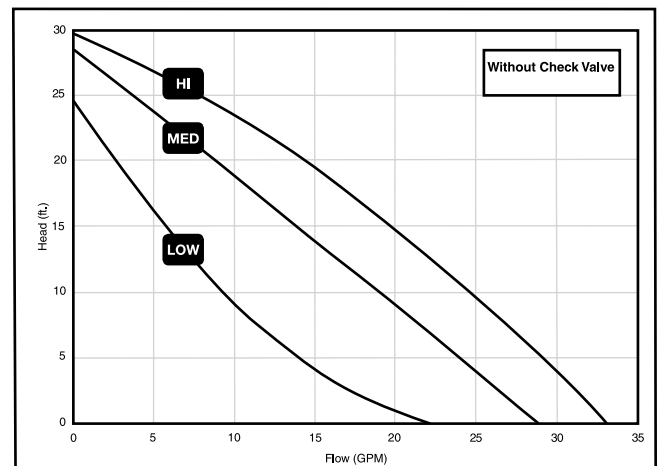

| Stock Code | Speed | Amps | Watts | HP |
|------------|-------|------|-------|-----|
| 12127 | HI | 1.8 | 197 | 1/6 |
| | MED | 1.5 | 179 | 1/6 |
| | LOW | 1.3 | 150 | 1/6 |

2.7 Typical Cross Sections

Section through Climate Panel installation above subfloor with hardwood finish floor

- Screw or staple Climate Panels to the subfloor perpendicular to the direction of the hardwood floor.
- Stagger the seams of the Climate Panels.

Important Note:

- In crawl spaces or moisture problem basements, install PE vapor barrier underneath the floor joists.
- Hardwood floor should always be installed in accordance with the flooring manufacturer's instructions.
- Maximum floor surface temperature = 85°F

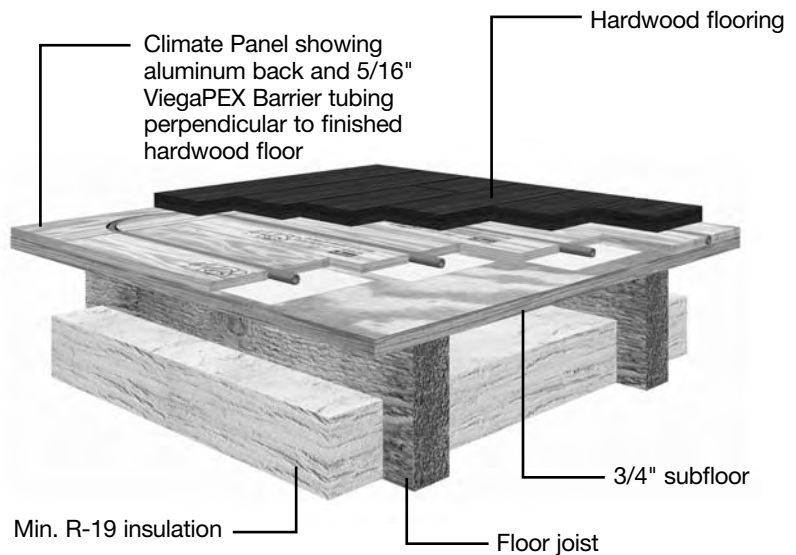

Section through Climate Panel installation above subfloor with tiles

- Screw or staple Climate Panels to the subfloor.
- Glue and screw concrete fiberboard to Climate Panels.
- Set tiles into thin set.

Important Note:

- The thickness of the plywood subfloor should always be installed in accordance with the local building code.
- Maximum floor surface temperature = 85°F

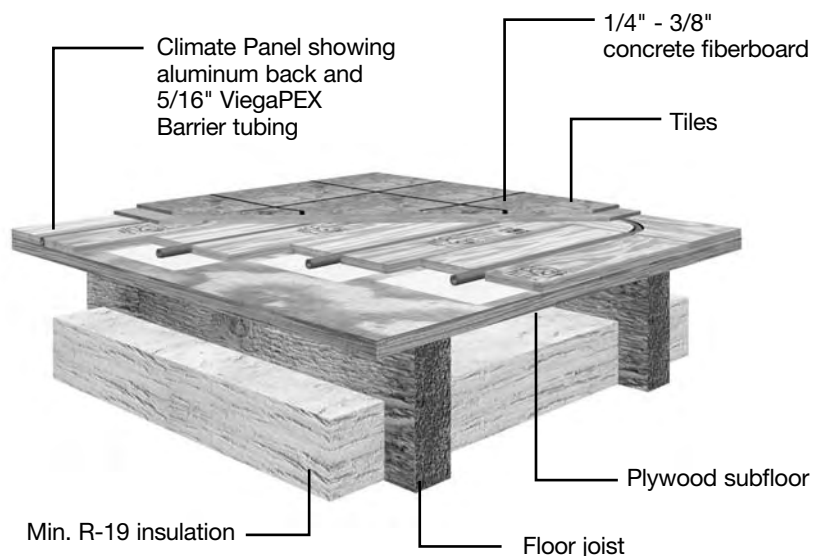

Section through Climate Panel installation above subfloor with carpet

- Screw or staple Climate Panels to the subfloor.
- Install carpet and pad with nailing strips.
- For minimum height buildup, install carpet and pad directly over the Climate Panels.
- If height allows, a luan plywood cover sheet can be installed over the Climate Panel system.

Important Note:

- **Always stay below a total R-value of 2.5 above Climate Panels (pad plus the carpet)**
- Maximum floor surface temperature = 85°F

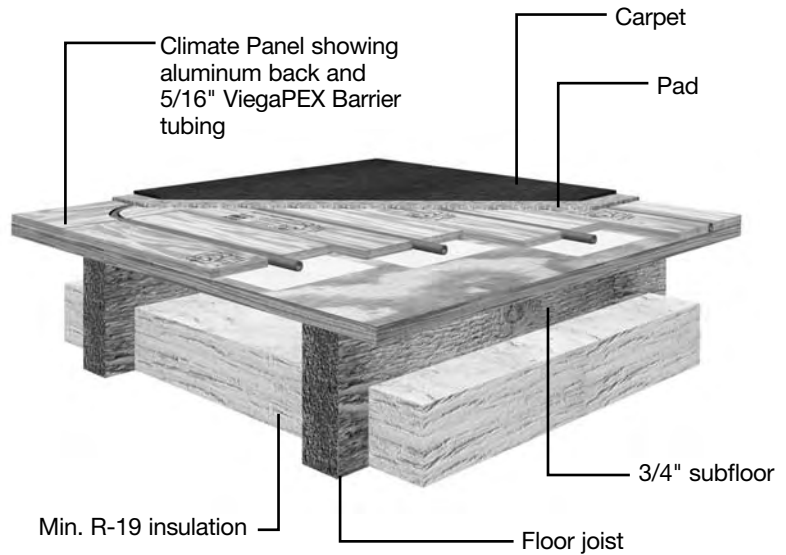

Section through Climate Panel installation above subfloor with linoleum or vinyl finish floor

- Screw or staple Climate Panels to the subfloor.
- Glue and screw plywood or concrete fiberboard to panels.
- Glue linoleum/vinyl to plywood or concrete fiberboard.
- Stagger the seams of the Climate Panels.

Important Note:

- Maximum floor surface temperature = 85°F

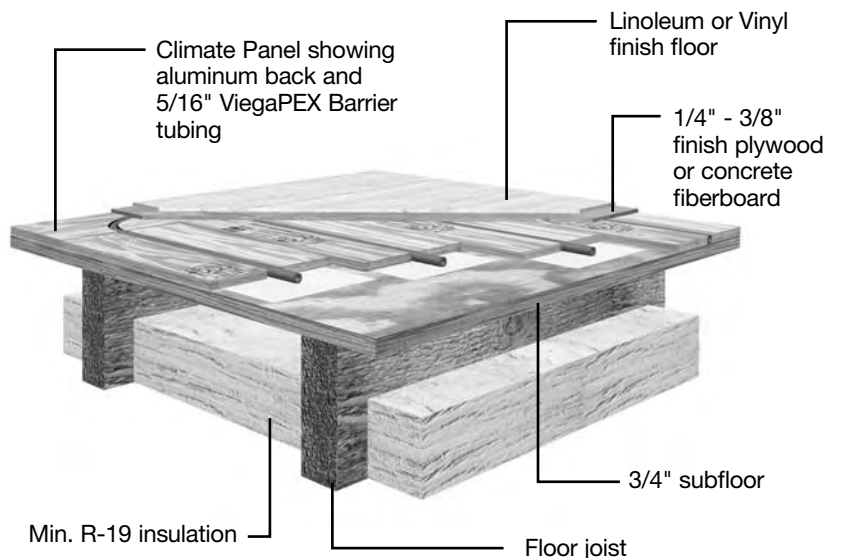

Section through Climate Panel installation on existing slab with plywood

- Cover level slab with 6 mil. (minimum) polyethylene film. Overlap edges 4-6".
- Loosely lay 3/4" plywood sheets over entire floor.
- Stagger plywood joints every 4' by cutting the first sheet of every other run in half.
- Fasten the plywood to the slab with a powder-actuated concrete nailer or hammer-driven concrete nails.
- Screw Climate Panels to plywood.

Important Note: Slab must be level prior to Climate Panel Installation.

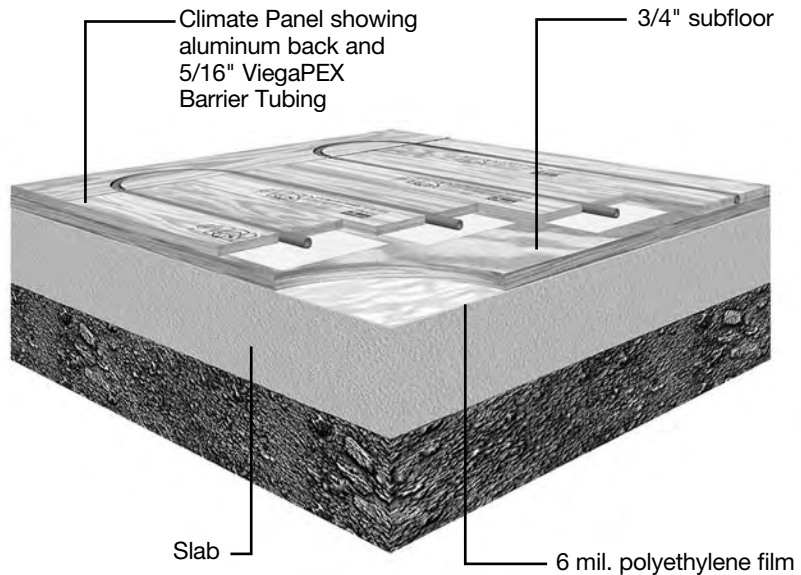

Section through Climate Panel installation on existing slab with floating floor

- Lay foam pad over level slab.
- Float Assembled Climate Panel (ACP).
- Tape all joints.
- Install floating floor system over Assembled Climate Panels.

Important Note: Slab must be level prior to Climate Panel Installation.

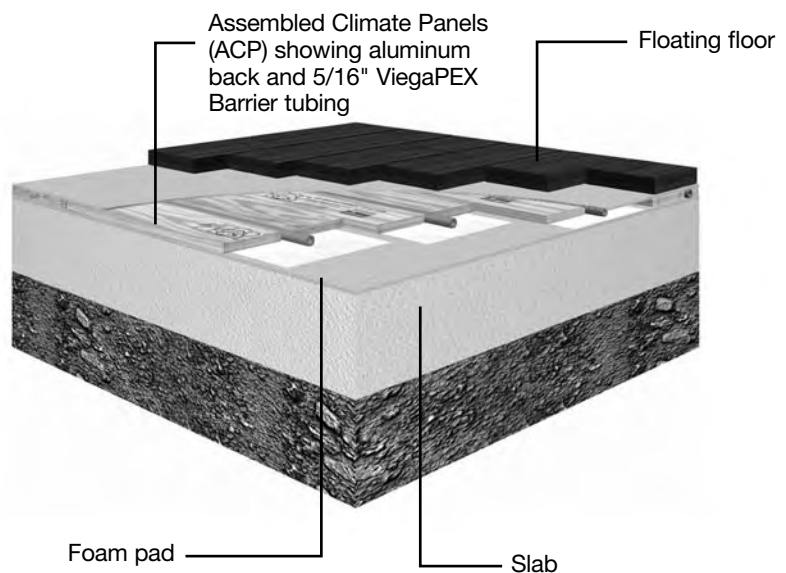

Section through Climate Panel installation in wall

- Start at the floor level on the outside wall.
- Install Climate Panels parallel to the floor.
- Install Climate Panels six rows high to avoid interference with window and picture placement.
- Screw Climate Panels to the studs on both sides of the groove.
- After Climate Panels are installed, attach 1/2" spacers to the remainder of the stud wall, to provide an even base for the concrete or gypsum wallboard.

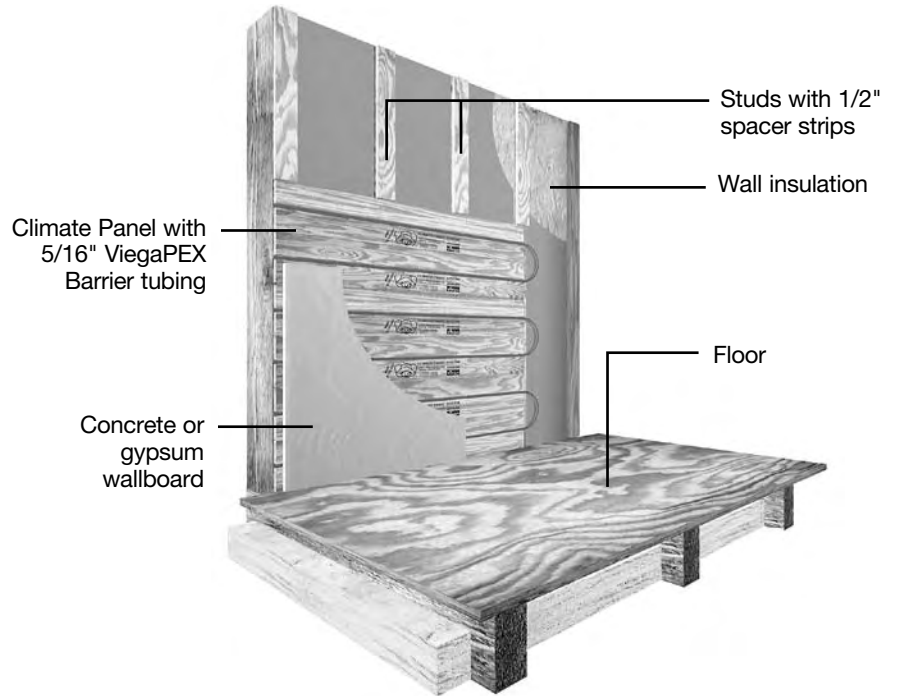

3. CLIMATE PANEL INSTALLATION

3.1 Layout Planning

To avoid waste and to have equal circuit lengths, a carefully planned layout should be done.

First, determine where the manifold should be installed. Remember, the manifold must be accessible. When calculating number of circuits, always round up! Keep length of each circuit in the same room equal.

| Maximum Circuit Length | | |
|------------------------|--------------------------------------|------------------------------|
| Tubing | 25 Btu/h/ft. ² or less | 25-35 Btu/h/ft. ² |
| 5/16" ViegaPEX Barrier | 250 feet | 200 feet |

Calculating number of circuits:
 $\text{Total amount of tubing} \div \text{Maximum circuit length} = \# \text{ of circuits}$

Manifold is located in basement supplying circuits from below.

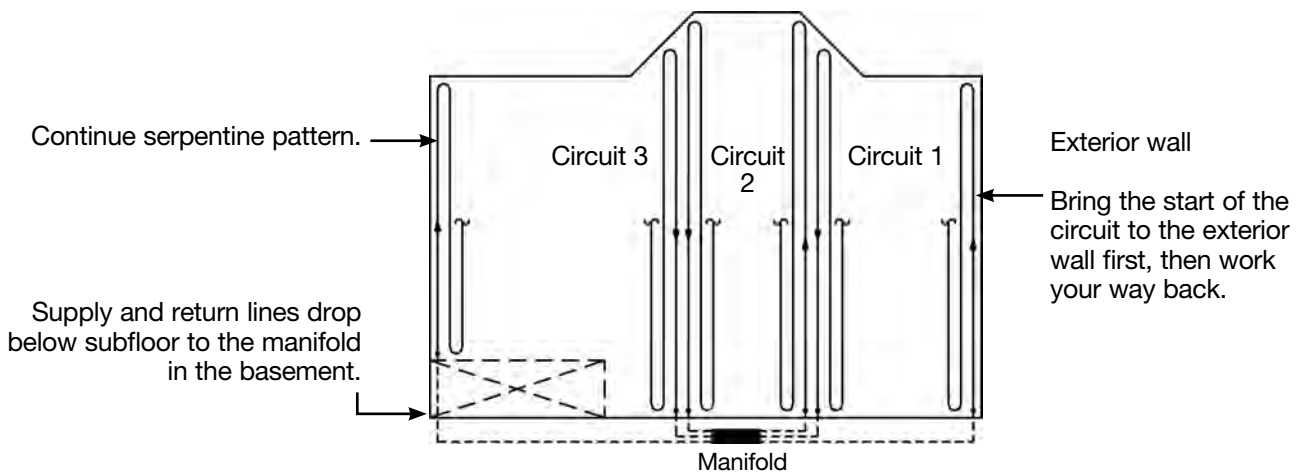

Manifold is located in the wall with access panel.

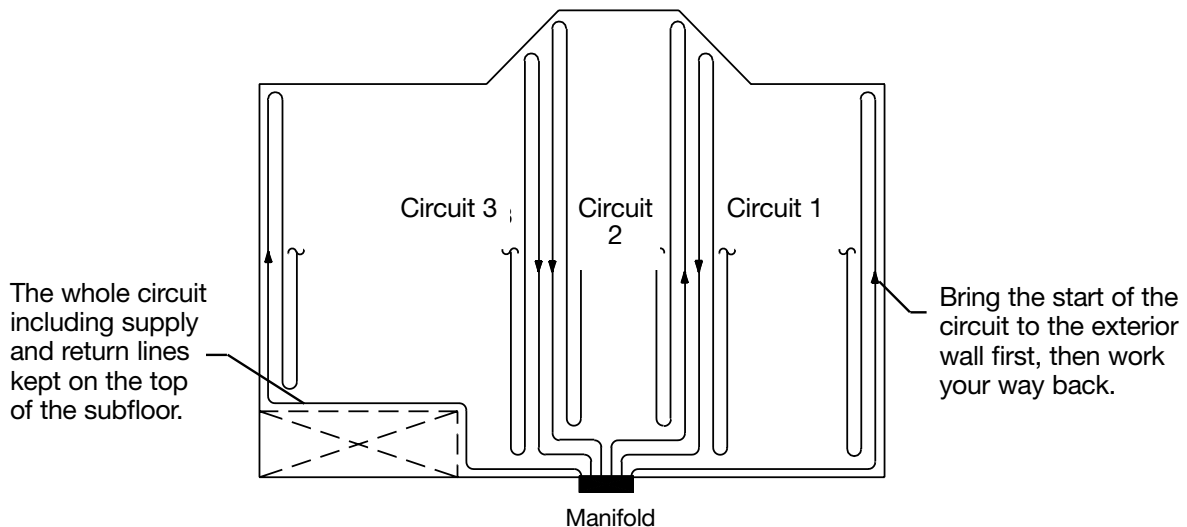

3.2 Panel Installation

Step 1:

Decide the proper direction of the Climate Panels.

Tile finish floor

If tiles will be installed over the Climate Panels, run the panels perpendicular to the floor joists. This stiffens the floor for a more stable tile installation. Aligning the ends of each panel to lie on a joist is optional, but will allow fasteners to attach panels, subfloor and joists together.

Carpet or vinyl finish floor

If the finish floor will be carpet, linoleum, or vinyl, the direction of the Climate Panels is not critical.

Where possible, running the panels perpendicular to the floor joists will strengthen the floor and reduce deflection.

Hardwood finish floor

Where hardwood flooring will be installed over the Climate Panel system, always run the panels perpendicular to the direction of the hardwood planks (regardless of the joist direction). This will keep tubing visible during floor nailing and reduce the possibility of accidental tubing puncture.

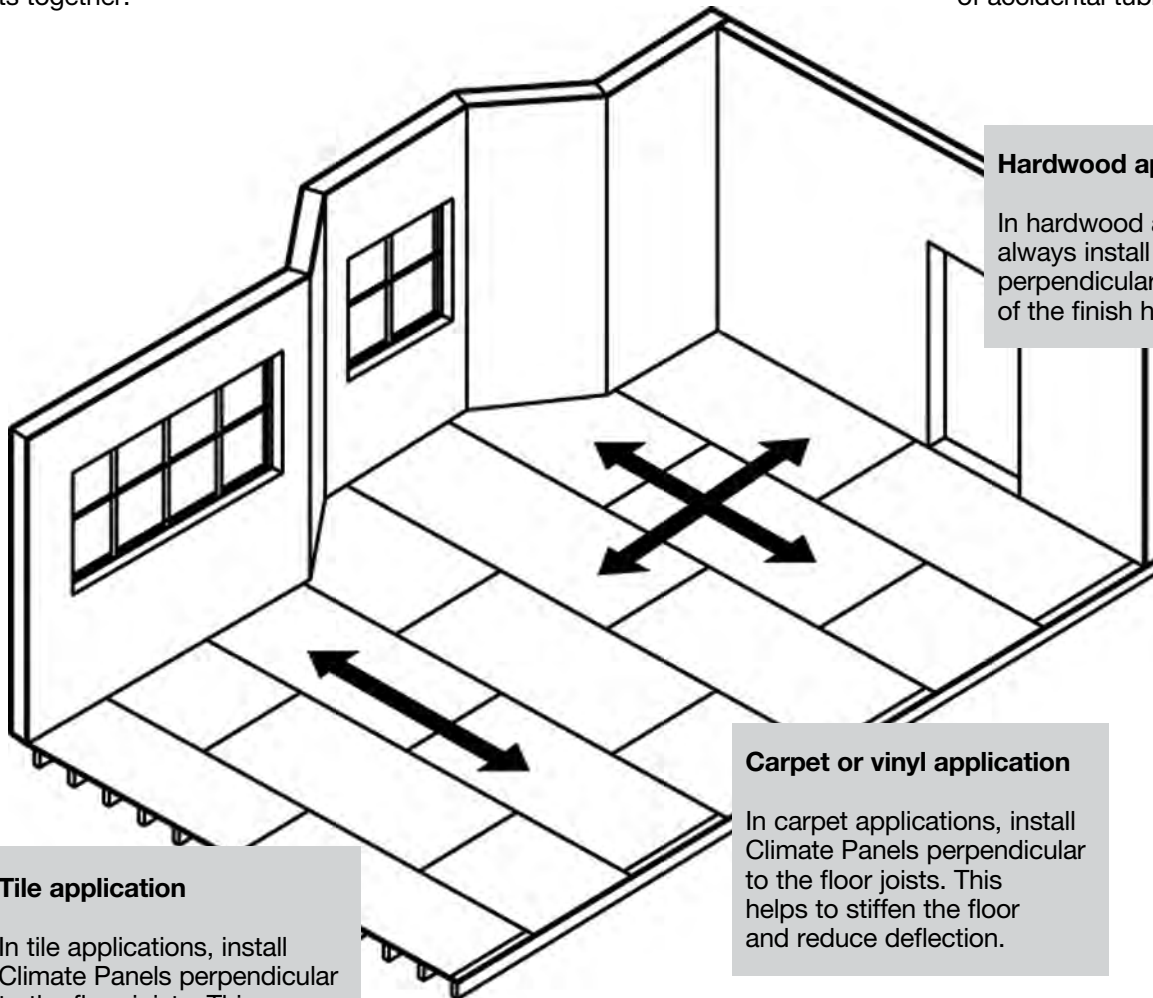

Tile application
In tile applications, install Climate Panels perpendicular to the floor joists. This helps to stiffen the floor and reduce deflection.

Carpet or vinyl application
In carpet applications, install Climate Panels perpendicular to the floor joists. This helps to stiffen the floor and reduce deflection.

Hardwood application
In hardwood applications, always install Climate Panels perpendicular to the direction of the finish hardwood floor.

Step 2:

Because most rooms are not perfectly square, lines need to be chalked to ensure proper layout of the Climate Panels.

Begin by chalking a line along the wall where the first row of panels will be laid out. The line should be 7-1/4" from the wall.

Next, chalk lines along the walls where the U-Turn Strips will be laid out. One way to ensure that the chalk lines are perpendicular to each other is to use the right triangle rule – $a^2+b^2=c^2$ – also known as the 3, 4, 5 triangle.

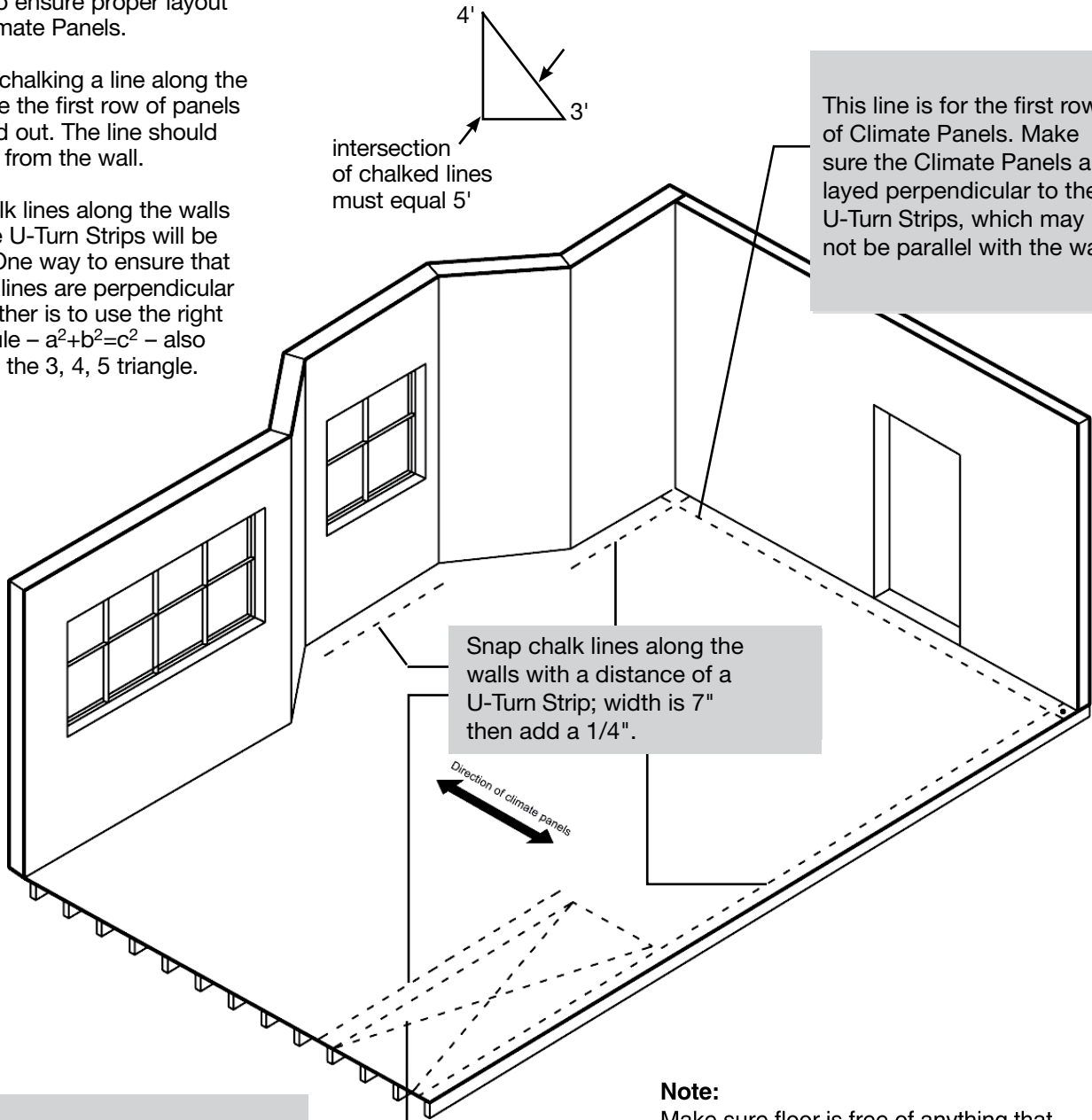

This line is for the first row of Climate Panels. Make sure the Climate Panels are laid perpendicular to the U-Turn Strips, which may not be parallel with the wall.

Snap chalk lines along the walls with a distance of a U-Turn Strip; width is 7" then add a 1/4".

Mark out the area that doesn't require floor heating such as kitchen cabinets.

Note:
Make sure floor is free of anything that would inhibit the climate panels from laying down flat (screws, woodchips, dried plaster, damaged plywood, etc.).



Step 3:

Start installing the Climate Panels.

Begin laying out panels along chalked line. Use single panels to ensure they are lined up with the line. This row will act as a guide for the ACPs laid down afterwards, allowing for faster installation. Be sure to fasten down row of single panels before you begin to lay out the ACPs.

Start installing Climate Panels along the chalk line. Do not butt them against the wall, because walls are not always square or straight.

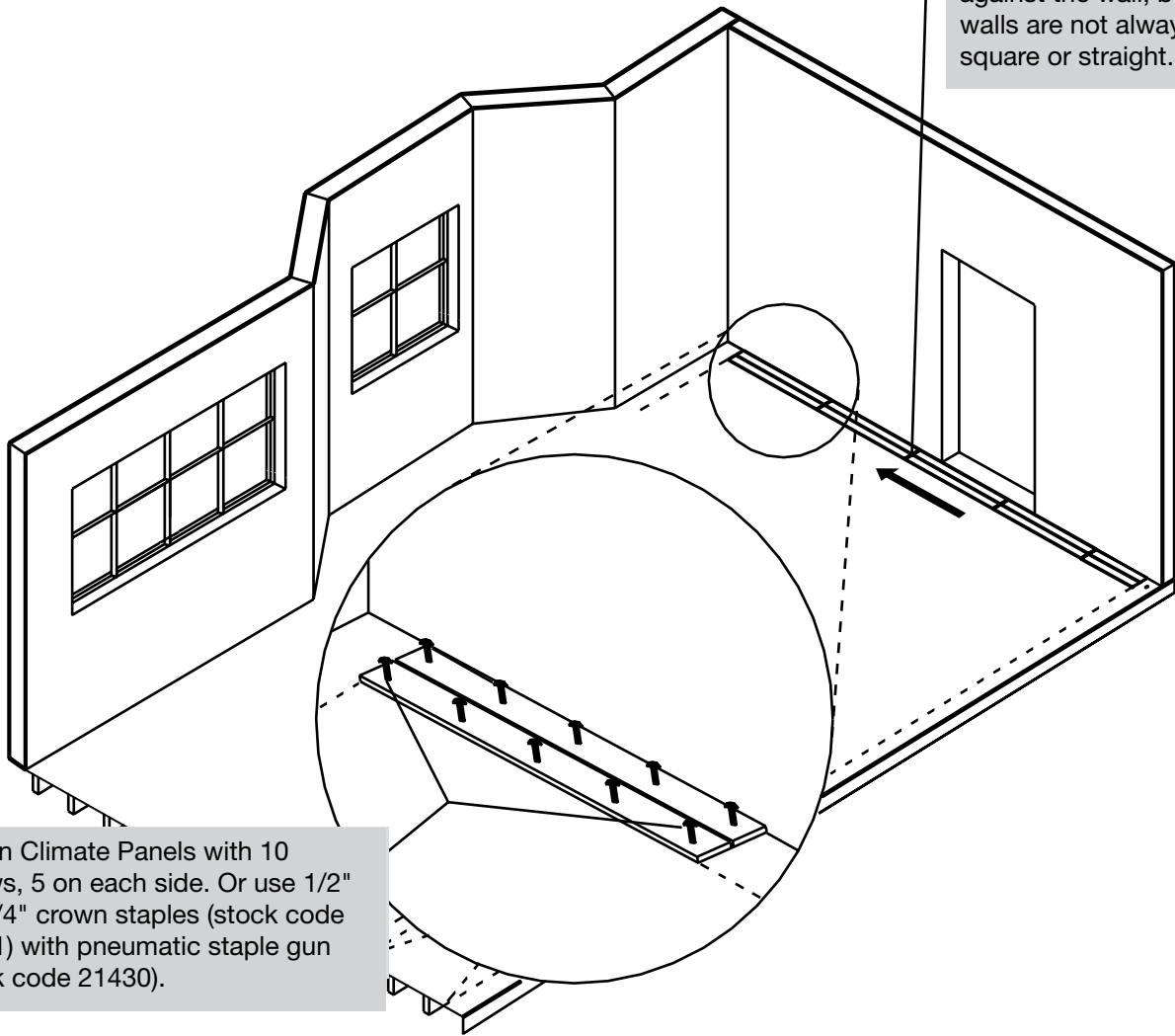

Fasten Climate Panels with 10 screws, 5 on each side. Or use 1/2" x 1-1/4" crown staples (stock code 21431) with pneumatic staple gun (stock code 21430).

Step 4:

Stagger the Climate Panels.

To begin ACP installation, cut an unopened bundle in half to create a straight edge to begin with. Be sure the ACP is completely flush with the first row already fastened down before you begin to fasten the ACPs. After the first row of ACPs has been laid out, begin to stagger seams.

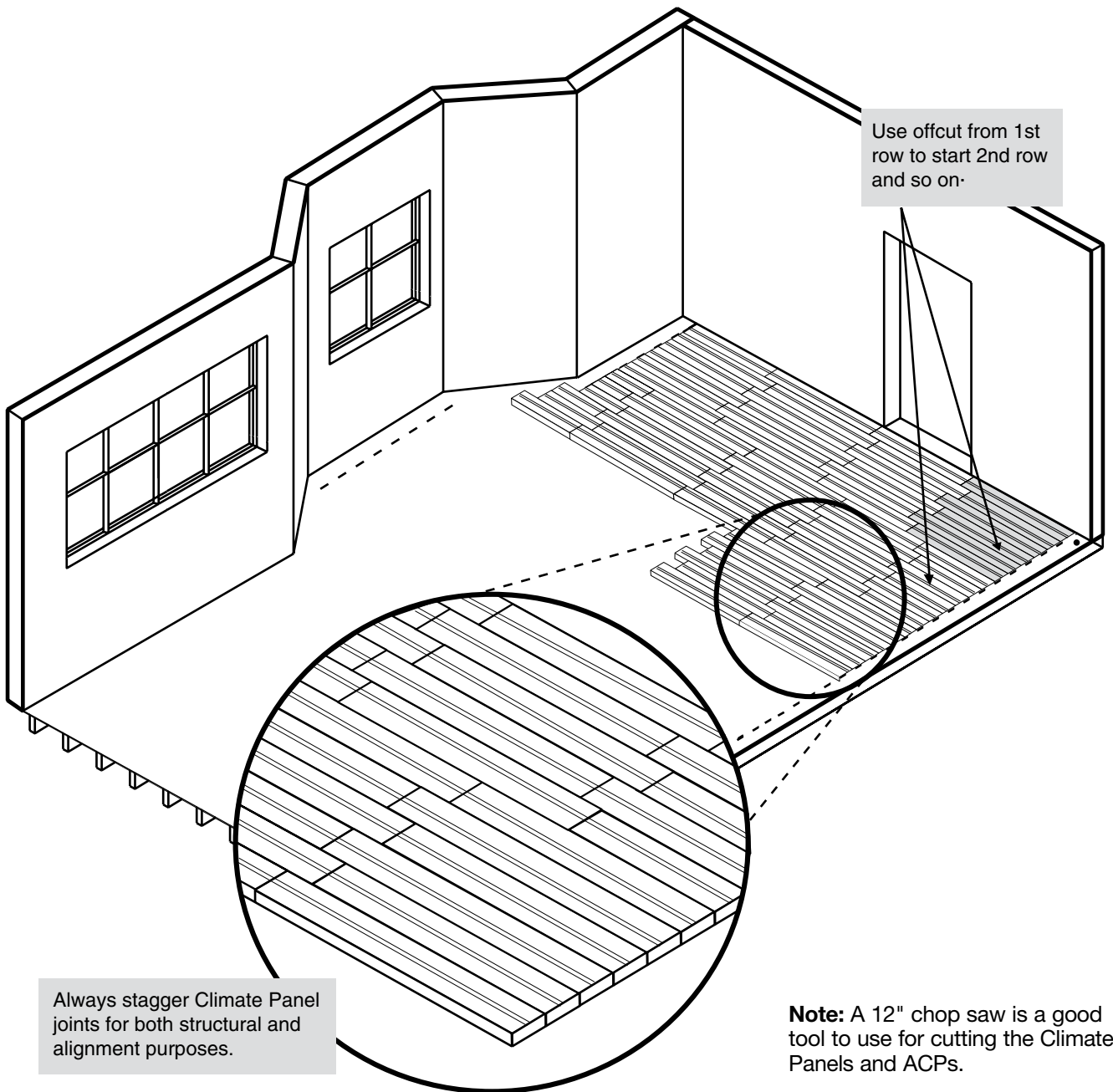

Step 5:

Install the Climate Panels, then the U-Turn Strips.

When laying down U-Turn Strips, be sure to first put down the aluminum sheets provided in each U-turn bundle. After the aluminum is laid out, align U-Turn Strips up with the correct tracks and fasten.

Sometimes due to large expansion spaces or uneven walls, adjustments must be made in u-turns.

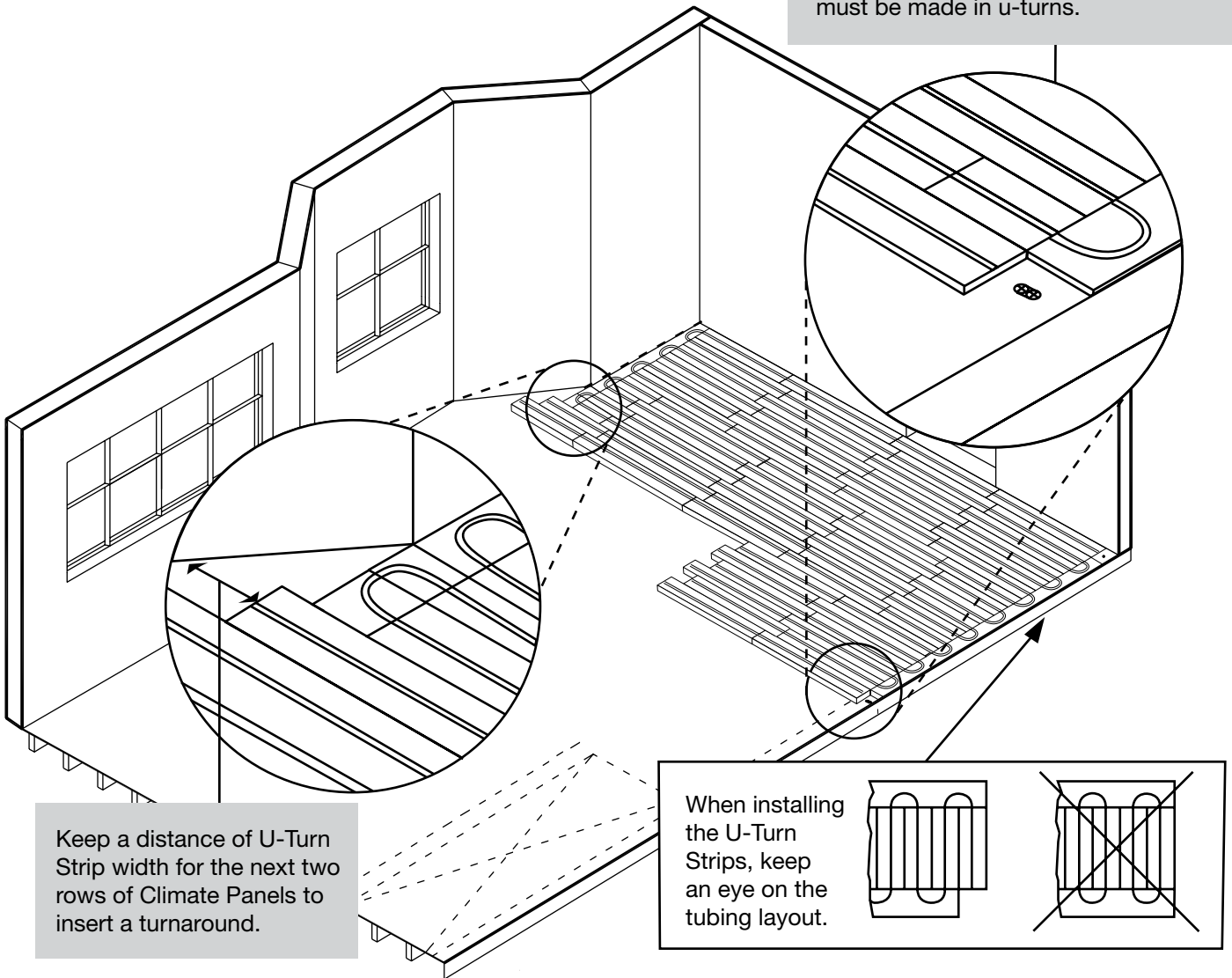

Keep a distance of U-Turn Strip width for the next two rows of Climate Panels to insert a turnaround.

When installing the U-Turn Strips, keep an eye on the tubing layout.

Note: A utility knife is a good tool to use for trimming the aluminum sheets needed under turnarounds (score, bend, break).

Step 6:

Install the Climate Panels, then the u-turns.

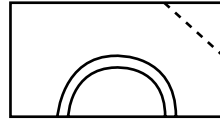

Cut turnaround pieces in area shown at the same angle as the wall to maximize heated area while minimizing the area that needs to be filled in, especially along the exterior walls.

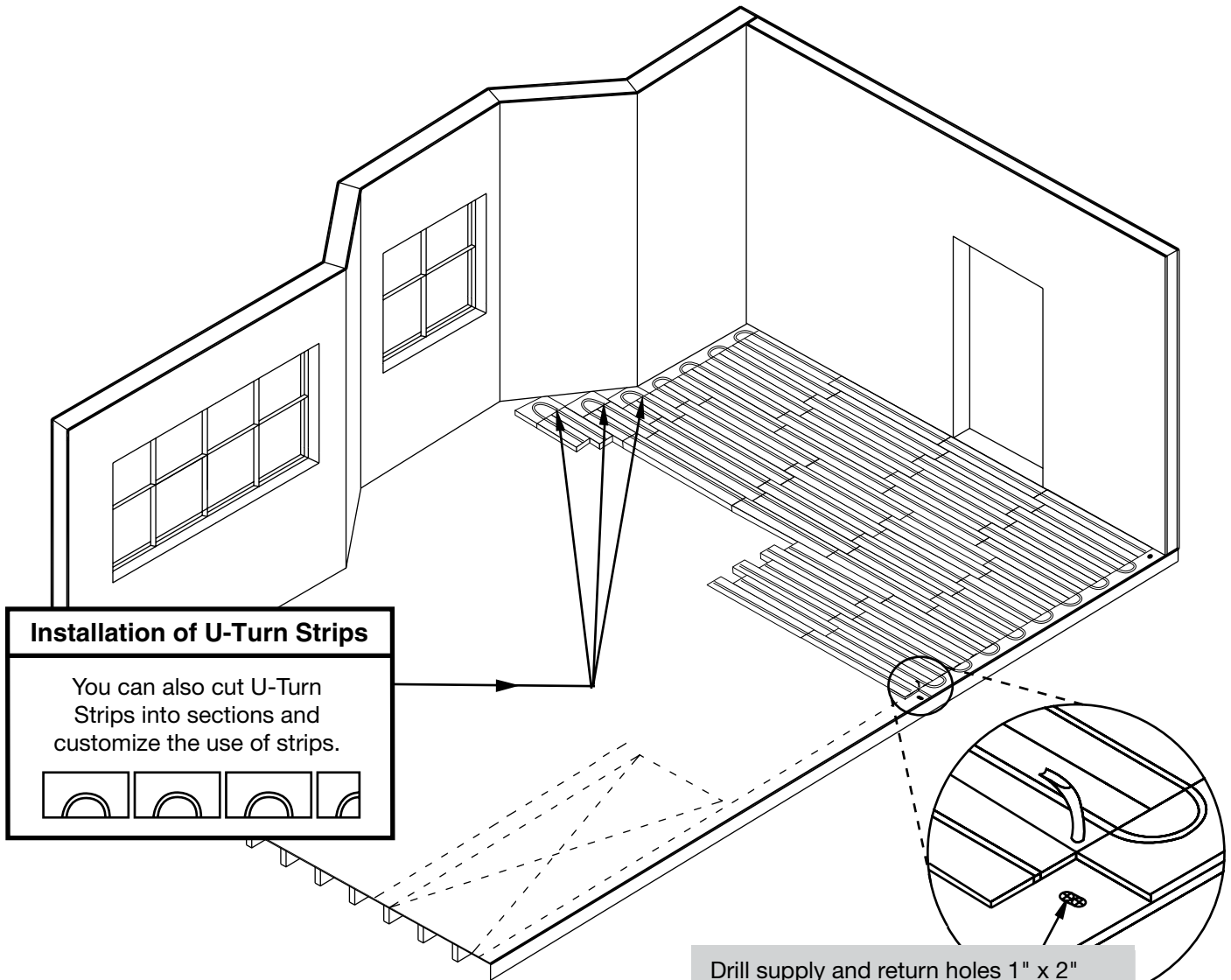

Drill supply and return holes 1" x 2" long. After the holes are drilled, use a chisel (if needed) to create a smooth ramp-like surface in which the Plastic Elbow Sleeve with Clip (stock code 15104) is to be inserted.

Step 7:

Install the Climate Panels one circuit at a time.

To minimize the chance of damaging the tubing while installing, use a utility knife to nip any corners at turnarounds that did not line up perfectly.

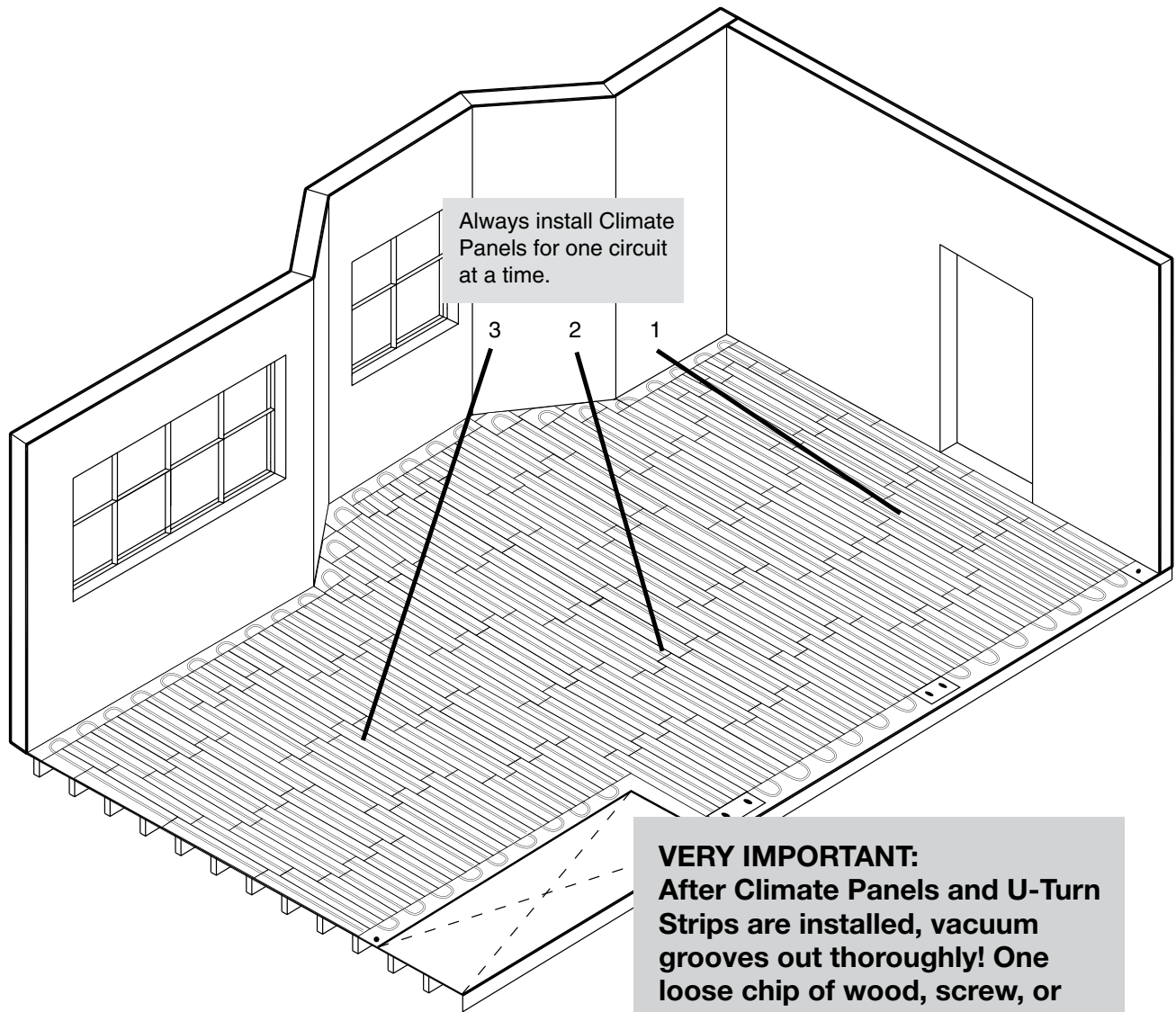

VERY IMPORTANT:
 After Climate Panels and U-Turn Strips are installed, vacuum grooves out thoroughly! One loose chip of wood, screw, or nail can damage the tubing or impede level installation.

3.3 Assembled Climate Panel Installation

The Assembled Climate Panel (ACP) system serves two important functions:

1. The ACP units are a time and labor saving device. The hinged units of six panels can be spread out and interlocked quickly, dramatically decreasing installation time when installed over a plywood subfloor.
2. The ACP system can be installed over existing concrete slabs as a floating floor system (refer to 2.7 Typical Cross Sections).

*When floating the panels, tape joints in between ACPs.

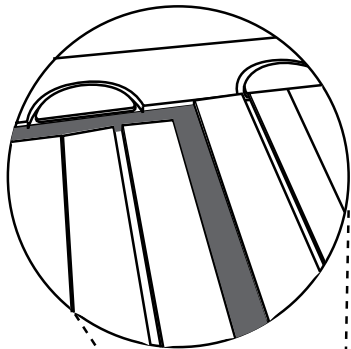
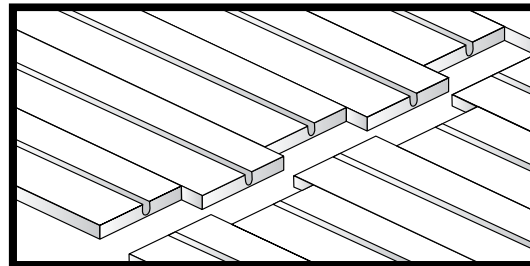

Cut the ACP unit to fit flush against the u-turn, then use the other half to start the next six rows parallel to this set.

OR

Cut the staggered ends of the ACP system to make the end flush against the u-turn.

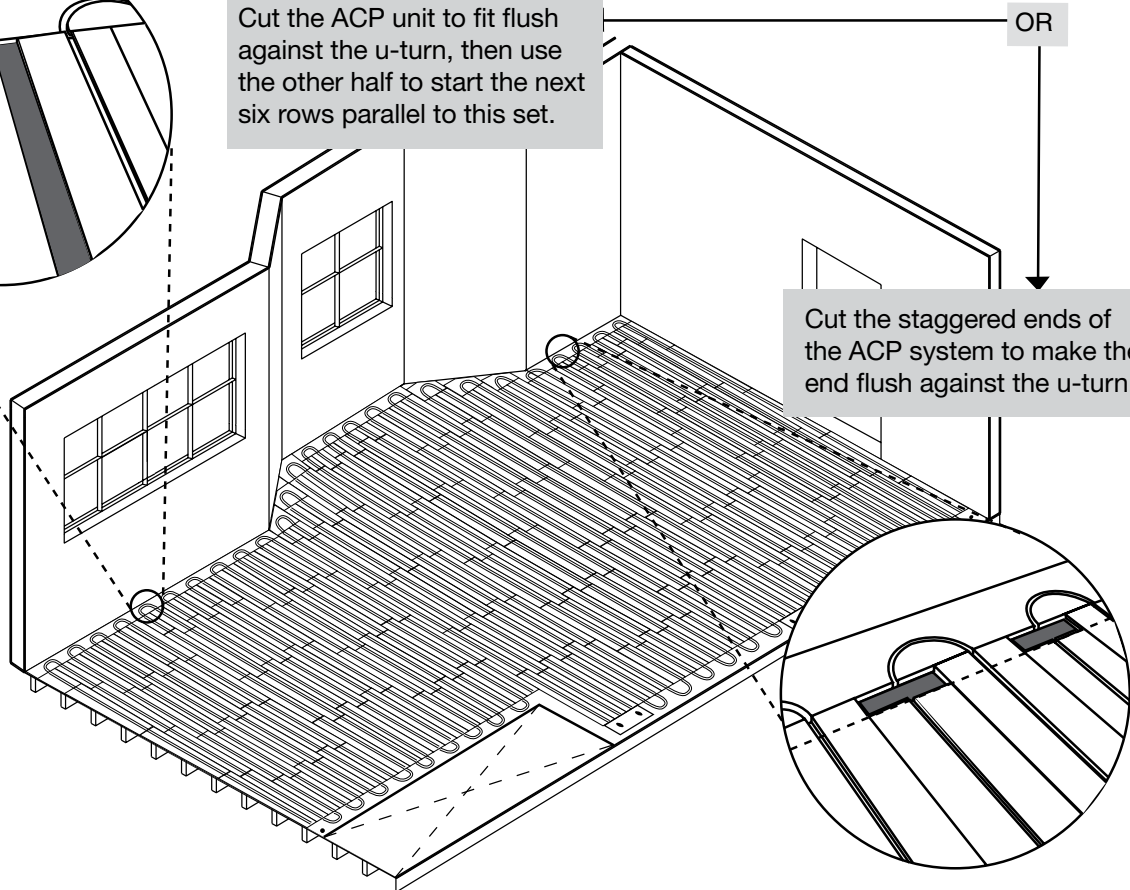

3.4 Tubing Installation

After Climate Panels and U-Turn Strips are installed, vacuum groove out thoroughly just prior to installing tubing.

If trapped in the groove, any debris, screws, nails, etc. will damage the tubing and keep it from lying flush with the top surface. When penetrating the floor, use a plastic elbow sleeve:

1. Figure the leader length of the supply line to the manifold area.
2. Feed leader length through plastic elbow sleeve (be careful not to scratch the tubing in the process).

Note: Feed the tubing through an unsecured plastic elbow sleeve.

3. Feed the leader length through the floor.
4. Secure the fastener clip to the floor.

Directly before installing tubing into the Climate Panels, run a 3/16" to 1/4" bead of Viega's Groove Tube silicone into the panel grooves.

- Guaranteed not to damage PEX tubing or aluminum, the Groove Tube is strongly recommended.
- Do not use anything but 100% silicone rated for 180°F!
- Do not use caulking or any other type of sealant or adhesive!

Installers: Since silicone becomes tacky in 8 to 10 minutes, it is recommended that silicone is applied only to a section that can be covered in this amount of time.



Directly after the Groove Tube silicone installation (before it cures), walk tubing off a decoiler into the Climate Panel groove.

- Silicone and tubing installation must go hand-in-hand, i.e. do not let silicone set up before tubing is inserted.

Note: It is imperative to make sure tubing is completely in its tracks before silicone hardens. Tubing may have to be hammered in using a rubber mallet or a



pneumatic soft-tipped palm hammer.

Run supply tubing from manifold supply valves into high heat loss areas first (i.e. closest to exterior walls, windows, sliders, etc.), and then into the interior of the room.

This will provide more BTU output where it is needed due to higher water temperatures. Continue the circuits, laying them out in the same direction toward the interior of the room.

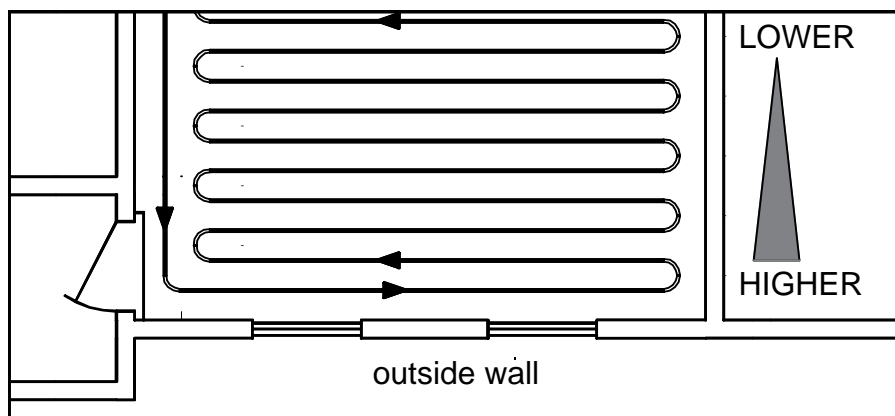

4. PIPING AND CONTROLS INSTALLATION

4.1 Mixing Station/Injection Station and Manifolds

Mixing Station Includes (shown below)

- 2 - Ball valves
- 1 - Pump (low, medium, high)
- 1 - Diverting valve with integrated high temperature limit
- 2 - 6-5/8" Spacing mounting brackets

Injection Station Includes

- 2 - Ball valves
- 1 - Pump (low, medium, high)
- 2 - Purge valves
- 1 - Injection valve
- 3 - 11" Spacing mounting brackets (1 for station, 2 for manifold)
- 1 - Manifold Connection Set

Options

Two position actuator

Three position actuator

Modulating safety high limit (used only with Injection Station)

1-1/4" Stainless Manifold Includes (shown below)

2 - 6-5/8" - Spacing brackets (for compact remote mounting)

2 to 12 - Outlets per header

2 to 12 - Balancing valves on supply header for flow adjustment from 0-2 GPM

2 to 12 - Shut-off valves on return header designed to receive powerheads (15061)

Built-in purge valves and air bleeders

1-1/4" Union Connections

1" NPT removable end caps

Other Manifolds Available

- 1-1/4" Stainless Manifold Shut-Off/Balancing/Flow Meters
- 1-1/4" Stainless Manifold Valveless
- 1" Brass Manifold (when using the brass manifold, an accessory kit is needed for proper air elimination and purging)

Options

- Powerheads
- Circuit temperature gauges (used with Stainless Shut-Off/Balancing/Flow Meters only)
- SVC circuit ball valves
- Reducers for direct station attachment (needed for stainless manifolds only)

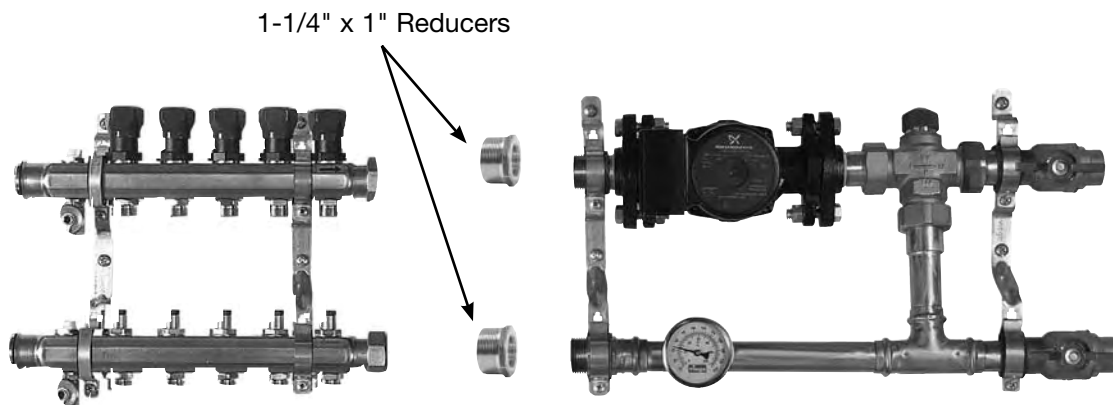

Note: It is important to use Teflon tape and thread sealant paste on all connections without gaskets.

4.2 Single Temperature Radiant System

The Basic Heating Control is selected to modulate system water temperature as the outdoor temperature fluctuates. Multiple zones may be incorporated by adding Thermostats and a Zone Control.

| Material | Quantity | Stock Code |
|---------------------------------------|----------|---------------|
| Mixing Station | 1 | 12120 - 12125 |
| Basic Heating Control | 1 | 16015 |
| Indoor Sensor | 1 | 16016 |
| Three Position Actuator for Station | 1 | 18003 |
| 1-1/4" Stainless Manifold, # Outlets* | 1 | 15900-910 |

*Based on job requirements

| Primary Loop Sizing* | | |
|---------------------------|-----------------|--------------------------------|
| Copper Pipe Size (inches) | Flow Rate (GPM) | Heat Carrying Capacity (BTU/h) |
| 3/4 | 4 | 40,000 |
| 1 | 8 | 80,000 |
| 1-1/4 | 14 | 140,000 |
| 1-1/2 | 22 | 220,000 |
| 2 | 45 | 450,000 |

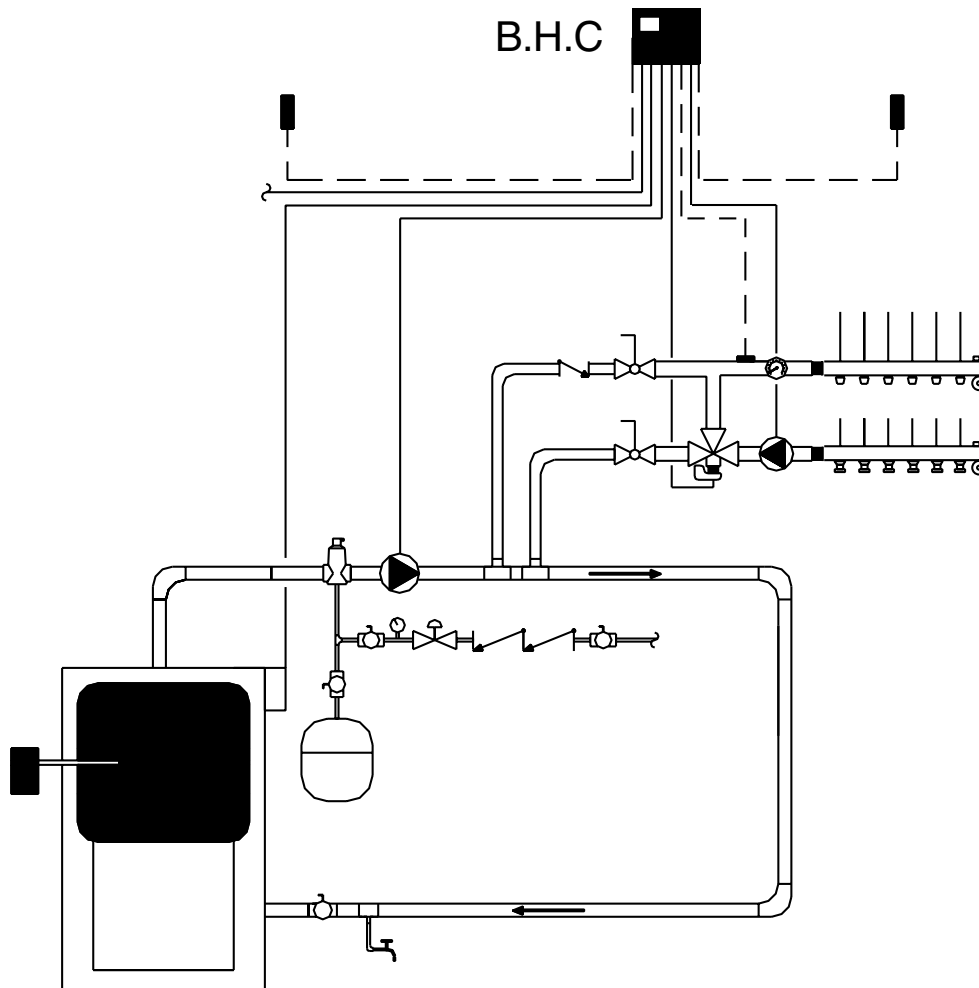

*Flow Rate and Heat Carrying Capacity calculation based on a 20°F temperature drop across the system.

Note: All schematics are conceptual. The designer must determine whether this application will work in the system and must ensure compliance with National and Local code requirements. Boiler trim (expansion tank, fill valve, relays, etc.) supplied by others.

4.2 Single Temperature Radiant System with Boiler Modulation and Optional DHW Control

The Advanced Heating Control incorporates low temperature mixing, provides boiler modulation, and the option of domestic hot water control with priority.

Optional DHW sensor may be in tank or on outlet piping. If boiler and DHW control are not needed, refer to Basic Heating Control diagrams.

| Material | Quantity | Stock Code |
|---------------------------------------|----------|---------------|
| Mixing Station | 1 | 12120 - 12125 |
| Advanced Heating Control | 1 | 16014 |
| Indoor Sensor | 1 | 16016 |
| Three Position Actuator for Station | 1 | 18003 |
| 1-1/4" Stainless Manifold, # Outlets* | 1 | 15700 - 15710 |
| Thermostats | * | 18002 |
| Powerheads | 3 | 15061 |
| Optional DHW Sensor | 1 | 16018 |
| Transformer 24V | 1 | 18008, 18020 |

*Based on job requirements

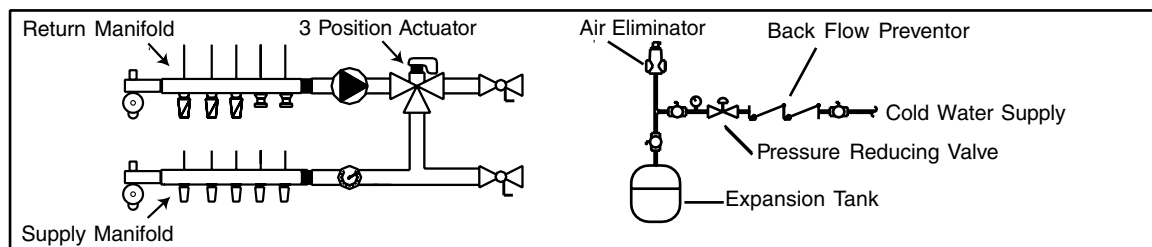
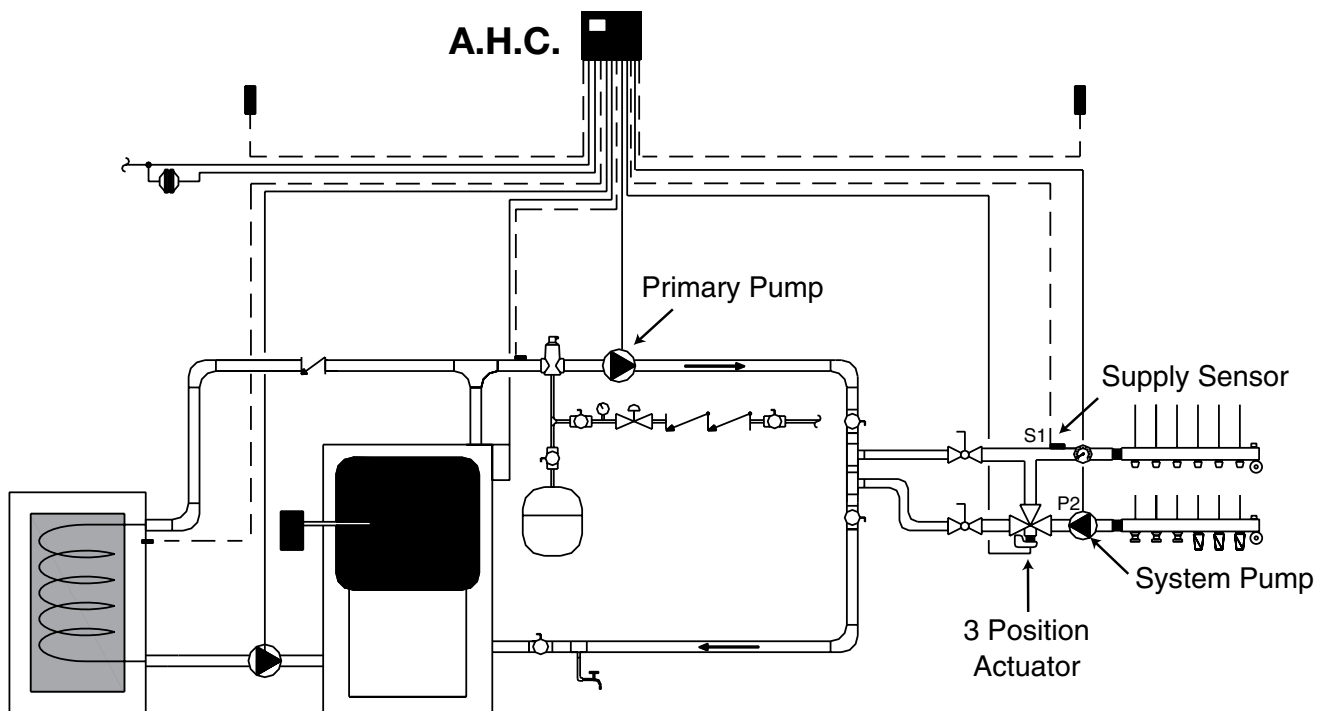

4.2 Multiple Temperature Radiant System with Boiler Modulation

Note: If the heat loss and required water temperature varies throughout a building, a multiple water temperature system may be required. To add an additional temperature system, pipe in another Mixing Station with the necessary controls.

| Material | Quantity | Stock Code |
|---------------------------------------|----------|---------------|
| Mixing Station | 2 | 12120 - 12125 |
| Basic Heating Control | 2 | 16015 |
| Indoor Sensor | 2 | 16016 |
| Three Position Actuator for Station | 2 | 18003 |
| 1-1/4" Stainless Manifold, # Outlets* | 2 | 15012 - 15022 |
| Zone Control | 2 | 18032 |
| Thermostats | * | 18029 - 18031 |
| Powerheads | * | 15061 |
| Optional DHW Sensor | 1 | 16018 |
| Transformer 24V | 1 | 18008, 18020 |

*Based on job requirements

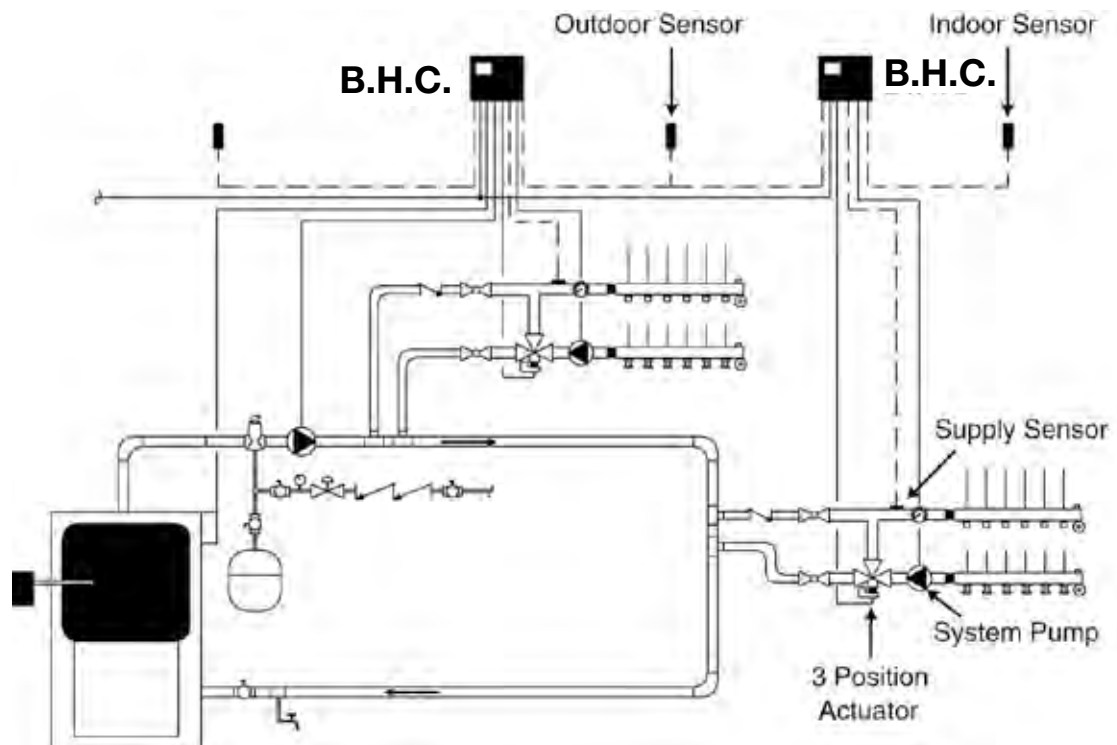

| Primary Loop Sizing | | | | | |
|---------------------------------|--------|--------|---------|---------|---------|
| Copper Pipe Size [inch] | 3/4 | 1 | 1-1/4 | 1-1/2 | 2 |
| Flow Rate* [GPM] | 4 | 8 | 14 | 22 | 45 |
| Heat Carrying Capacity [BTU/hr] | 40,000 | 80,000 | 140,000 | 220,000 | 450,000 |

*Based on 6 FPS

4.3 Zone Wiring

A manifold system allows any one or more of the circuits to be adapted for control by a thermostat. The following are typical zone wiring schematics.

Detailed wiring diagrams are provided with products.

Important Note:
Installation by a licensed electrician is recommended. Installation and use of this equipment should be in accordance with provisions of the U.S. National Electric Code, applicable local code and pertinent industry standards.

Wiring Schematic: One-Zone Application

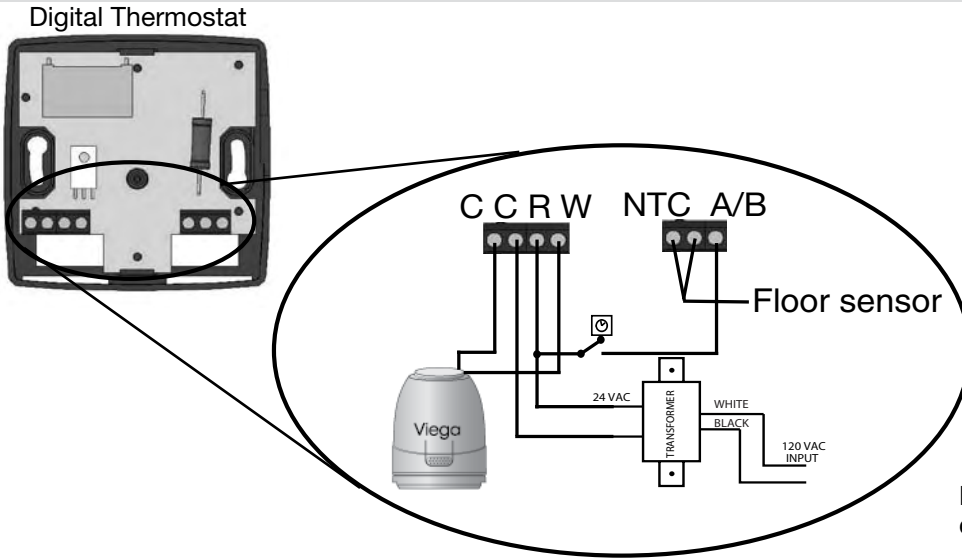

Note: Digital Thermostats can control up to 4 powerheads.

Wiring Schematic: Multi-Zone Application

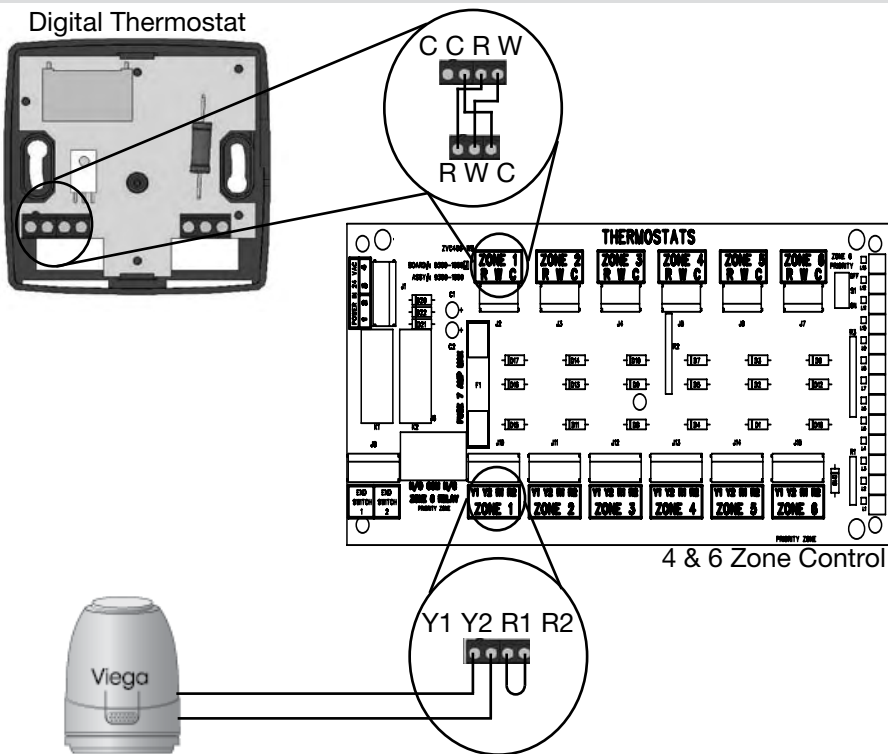

Note: 4 Zone Control (18060) can operate 8 powerheads. 6 Zone Control (18062) can operate 16 powerheads.

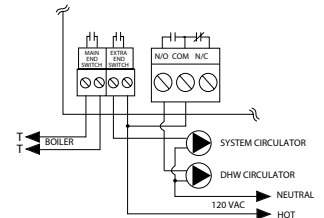

5. SYSTEM START-UP

5.1 Station and Actuator Installation

| Material | |
|--------------------------------|-----|
| Product | Qty |
| Mixing Station | 1 |
| Three Position Actuator | 1 |
| Stainless Manifold, # outlets* | 1 |
| Basic Heating Control | 1 |
| Indoor Sensor | 1 |
| FostaPEX | * |
| Press Adapters | 4 |
| Compression PEX Adapters | * |

*Based on job requirements

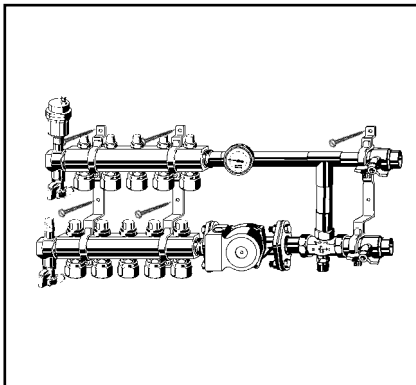

1. Mount the Mixing Station using the mounting brackets.

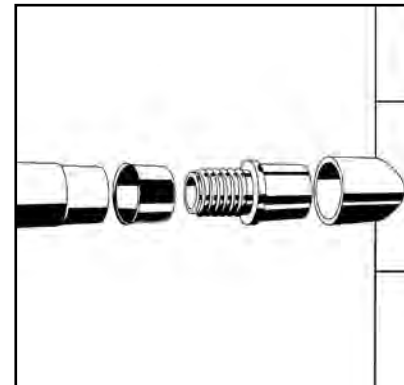

2. Make the press connection for the supply and return lines to the Mixing Station on the copper tee. Install tees as close as possible to keep pressure difference at a minimum.

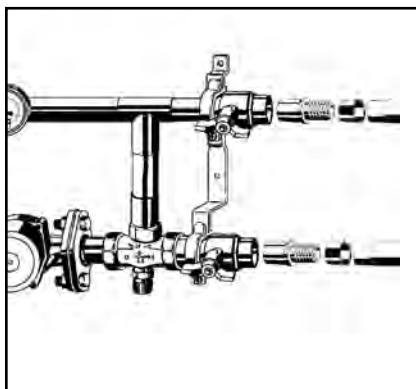

3. Connect the supply and return lines by soldering on a ViegapeX Press adapter, then pressing on ViegapeX Barrier or FostaPEX.

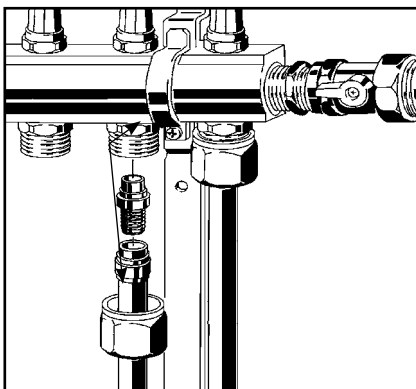

4. Use the SVC Compression or PEX Press Adapters to connect the ViegapeX Barrier lines to the manifold.

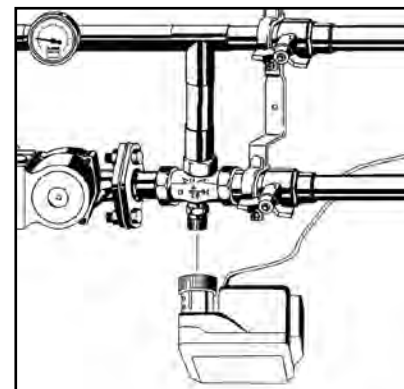

5. Remove the grey cap from the diverting valve on the Mixing Station and screw the actuator on hand tight. †

† Perform step 5 after the system has been filled and purged; refer to section 5.2 for procedure.

5.2 Purging and Pressure Testing the System

Operation

Purging

1. Attach drain hose to purge valve hose connection on return header and open valve.
2. Close all but one balancing valve on supply header (under red caps, turn with 5mm allen key). Close isolation ball valve on boiler return line. Remove plastic dust cap or temperature controller from diverting valve, and make sure that high-limit kit is fully open.
3. Open boiler fast-fill valve to purge circuit. After purging first circuit, close red balancing valve and open next one. Continue with one circuit at a time until all circuits have been purged.
4. Close purge valve and open all balancing and boiler valves. Reset high-limit kit and reinstall actuator onto diverting valve.
5. Any remaining air pockets in the system will be eliminated through the automatic air vent after a few hours of constant circulation.

NOTE: If the system must be purged again in the future for any reason, the high-limit kit must be reopened during purging for full flow.

Pressure Testing

Before the finish floor is installed, the radiant system must be pressure tested. Air or water may be used as the medium.

The following procedure is recommended by Viega. Check the local building codes for compliance or additional test requirements.

Procedure:

1. Double-check all connections to manifold to ensure proper seal.
2. Connect manifold pressurization kit (1) to any purge valve (2).
3. Pressurize the system to 80 psi to detect potential nail or screw penetrations.
4. The system should hold the 80 psi for a minimum of 24 hours.

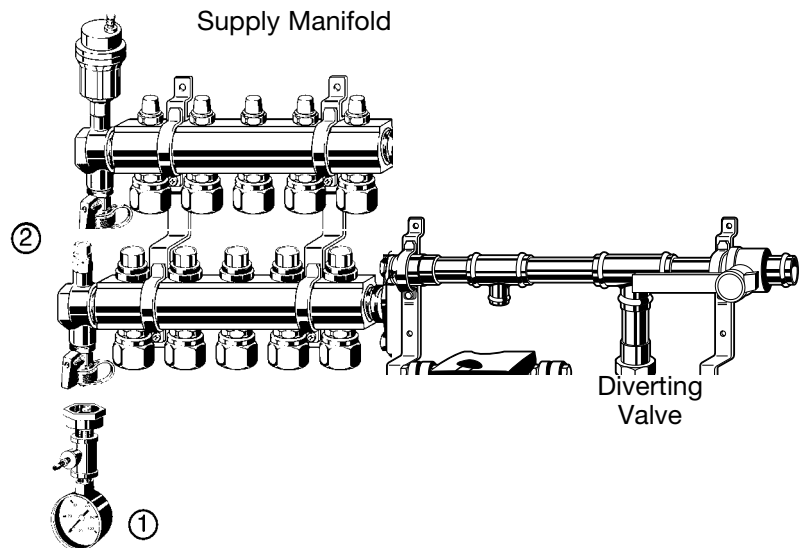

Note: If the tubing is damaged, repair punctured section with a compression coupling.



Contractor: Maintain pressure during the installation of the finish floor to simplify leak detection if tubing is damaged.

5.3 Adjusting the High-Limit Kit

Operation

The Mixing Station is provided with a preinstalled temperature high-limit kit. This kit is installed

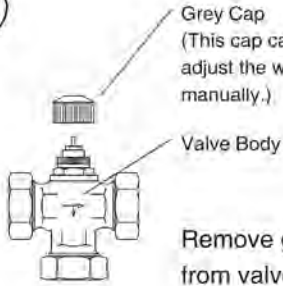
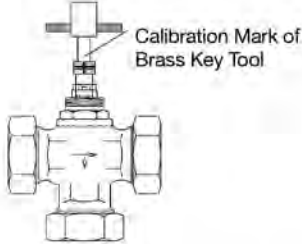
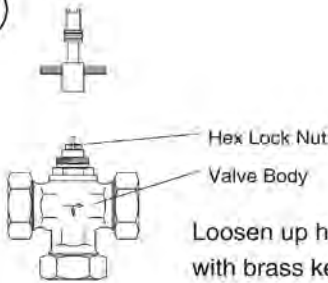
into the three-way valve to allow a maximum supply water temperature to be set. This kit must be unscrewed when purging the system and should then be set according to the instructions below.

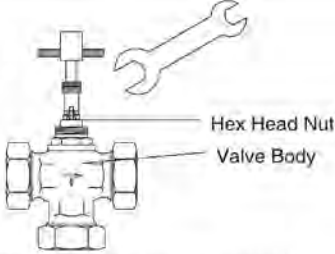
| | |
|--|--|
| <p>1</p>  <p>Remove grey plastic cap from valve body.</p> | <p>4</p> <p>Note: This calibration must be done with the boiler at its highest temperature, the circulator running and all zones open.</p>  |
| <p>2</p>  <p>Loosen up hex lock nut with brass key tool.</p> | <p>Turn adjustment screw further clockwise until desired supply water temperature is obtained; count quarter turns for reference. This has to be done carefully and slowly because each quarter turn of the adjustment screw will result in approximately 15°F temperature reduction. Wait until desired water temperature stays consistent.</p> |
| <p>3</p>  <p>Use opposite side of brass key tool and turn inner adjustment screw (slotted) in clockwise until valve spring resistance is felt.</p> <p>To lower water temperature, turn key clockwise; turn counterclockwise to raise it.</p> | <p>5</p>  <p>Tighten hex lock nut with wrench. Do not overtighten!</p> <p>To secure high limit adjustment hold slotted adjustment screw with brass key, while tightening lock nut.</p> |

5.4 Initial Balancing

Many times it is not possible to design the system using equal circuit lengths, so the system must be balanced in order to ensure adequate flow to each circuit on a manifold.

(Refer to your Radiant Wizard design program for detailed balancing).

Procedure:

1. Start with all valves wide open.
2. To decrease flow, turn the balancing valve clockwise in small increments.

Note: Remove red caps and turn balancing valves with included allen key. Valves are hidden to prevent tampering.

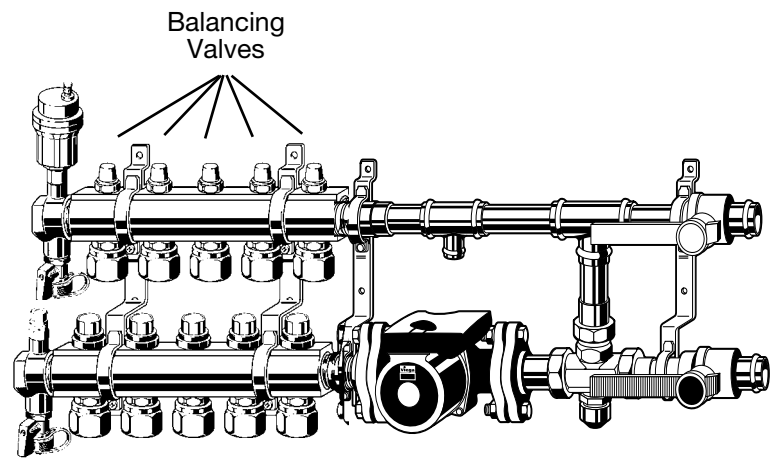

6. FINISH FLOORING

6.1 Choosing a Finished Floor

There are three common types of finished floors used in residential construction: wood floors, tile/vinyl and carpet.

When picking a finished floor, the lower the R-value, the better radiant heat will work. When using tile, the R-value will be low and therefore will work very well with your radiant system (Appendix E on page 38 lists some common tiles and their R-values). Vinyl flooring is another common choice for kitchens and baths and has a low R-value.

Using carpet over radiant heating requires careful planning. Viega's recommendation for a covering over a radiant system is to not exceed a total of a 2.5 R-value (the carpet pad plus the carpet itself). Remember that the pad and the carpet are insulators and will restrict the heat from getting into the room, so keeping the R-value of the pad and the carpet low is a must (Appendix E on page 38 lists some carpet and pad R-values). It may be necessary to add supplemental heat or install hydronic baseboards in rooms with heavy carpeting (see Viega's Combiflex system).

There are many questions regarding hardwood flooring over radiant heating. Armed with knowledge and a few precautions, hardwood floors and radiant heat will work well together. There are two important issues:

1. Floor surface temperatures
2. Moisture

Floor Surface Temperatures

For many builders, a reluctance to install hardwood floors over radiant heat stems from problems associated with incorrect control of the floor surface temperatures.

- Today, modern insulation and building techniques allow a radiant floor to stay cooler than the floor of the average sunroom.
- The floor surface temperature should not exceed 85°F (refer to section 2.4 to calculate the floor surface temperature).

Also be careful when using multiple or high R-value area rugs over hardwood flooring. Your radiant heating system must be designed with this additional R-value taken into account in order to perform properly. If the system was designed for bare wood flooring, adding area rugs may lead to a situation where heat output is diminished.

Moisture

Allow the radiant system to run for at least a week before installing the hardwood. This will ensure that the subfloor is dry. Wood flooring should be acclimated to the job site before installation. When checking the moisture content of the subfloor and wood flooring with a moisture meter, aim for a reading of 6% to 8%. Moisture will affect the hardwood floor with or without a radiant system.

- Moisture absorption causes wood to swell.
- Moisture loss causes wood to shrink.

If the moisture content of the wood is relatively high near the bottom of the plank, cupping upward will occur exaggerating cracks.

If the moisture content is relatively high near the top surface of the plank, it will crown downward on the edges.

Wet Expansion

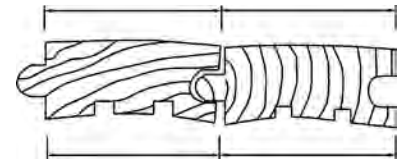

Sources from below:

- Inadequate moisture barrier
- Ground water wicking through the slab
- Unsealed subfloor

Sources from above:

- High relative humidity

Both solid plank flooring and engineered wood floors are acceptable choices over radiant heating.

Choosing narrower planks and harder woods minimizes dimensional change in the wood. Engineered wood flooring usually has less expansion and contraction and can be a good choice to minimize gaps between planks.

Note: Follow the flooring manufacturer's installation manual or NOFMA's (National Oak Flooring Manufacturers Association) manual.

Dry Shrinkage

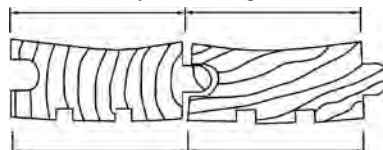

MAKING A PRESS CONNECTION - APPENDIX A

When piping a Mixing Station to a primary loop, FostaPEX is suggested. This method will produce a higher quality outcome, while reducing installation time.

Follow these steps each time you make a FostaPEX connection.

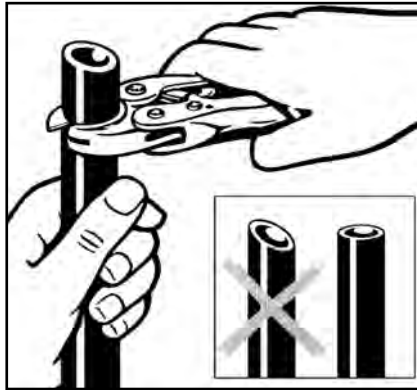

1. Square off tubing to proper length.

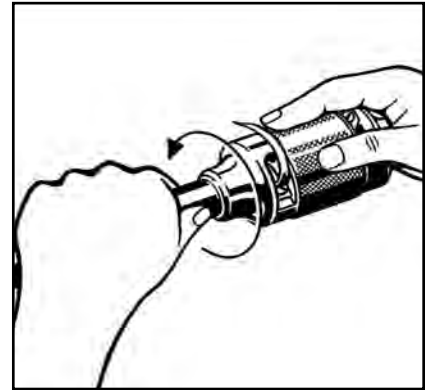

2. Insert FostaPEX tubing into prep tool. Push and turn tool until no more resistance is felt and tool spins freely. (This step applies to FostaPEX only.)

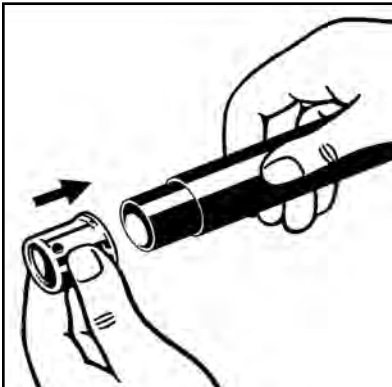

3. Slide press sleeve fully over end of tubing.

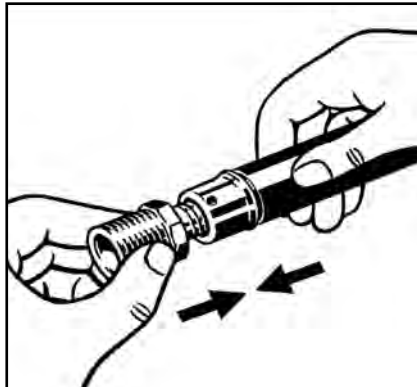

4. Insert compression fitting into tubing and engage fully.

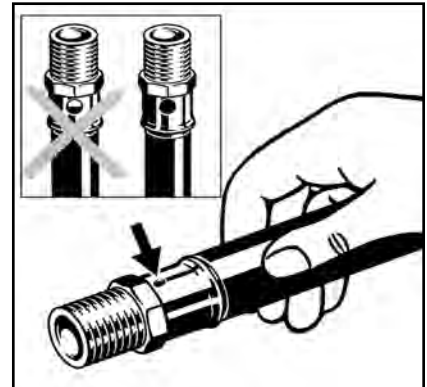

5. Check full tubing insertion at view hole of sleeve.

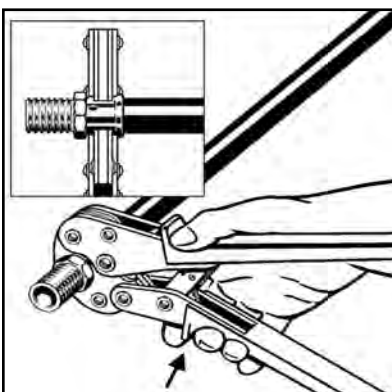

6. Engage press tool perpendicular over press sleeve and close tool jaws.

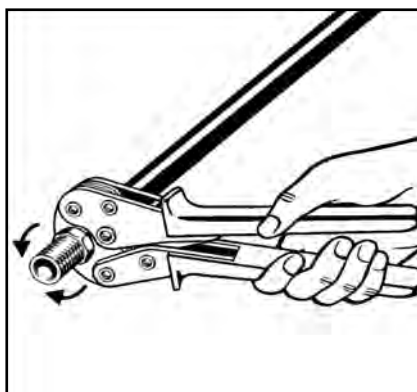

7. Start tool ratchet until automatic tool release occurs at proper compression force.

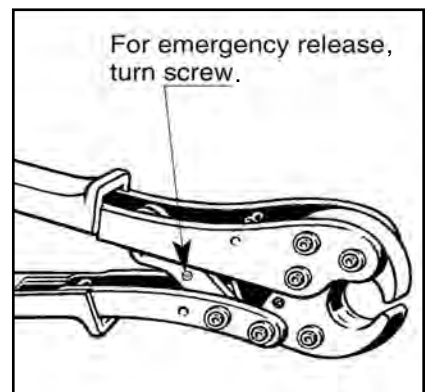

8. Warning: The connection is not leakproof when the tool has been opened by emergency release.

COMPRESSION COUPLING 5/16" PRODUCT INSTRUCTIONS - APPENDIX B

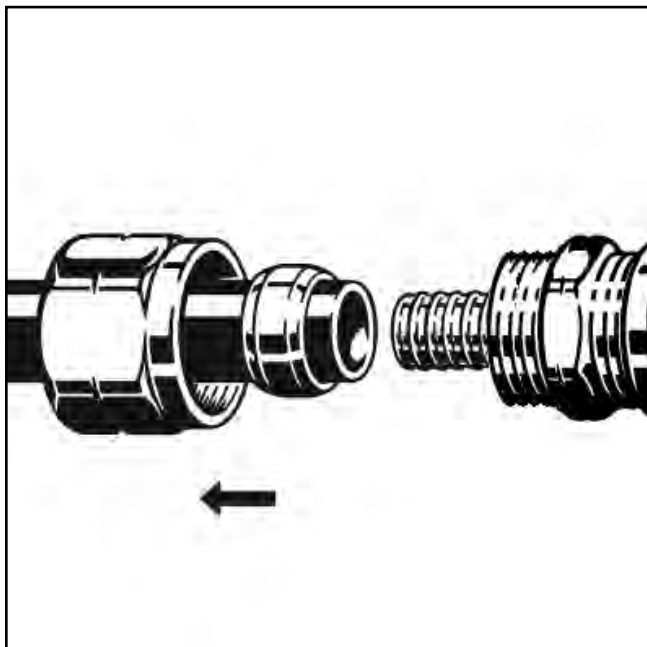

1. Square off tubing to proper length. Slide compression nut up tubing and slip brass ferrule over tubing.

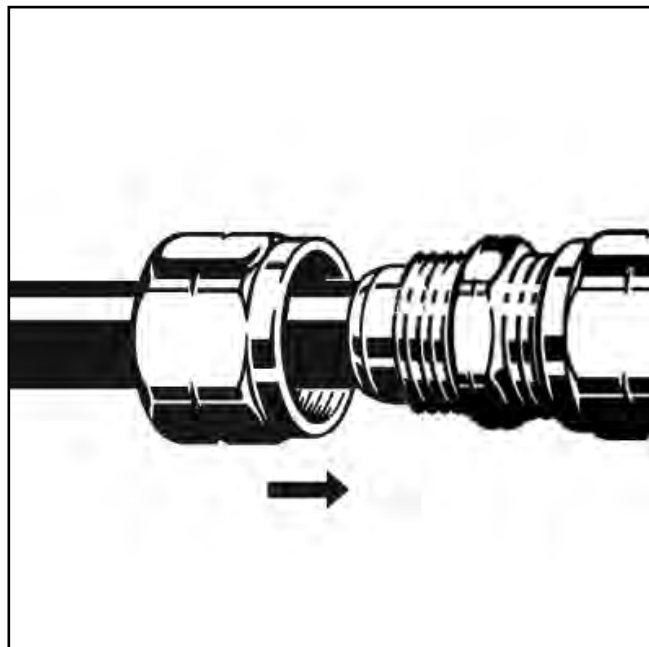

2. Slide tubing onto coupling barb, pushing it on fully until tubing is flush with shoulder of fitting. Slide ferrule up to the shoulder of fitting.

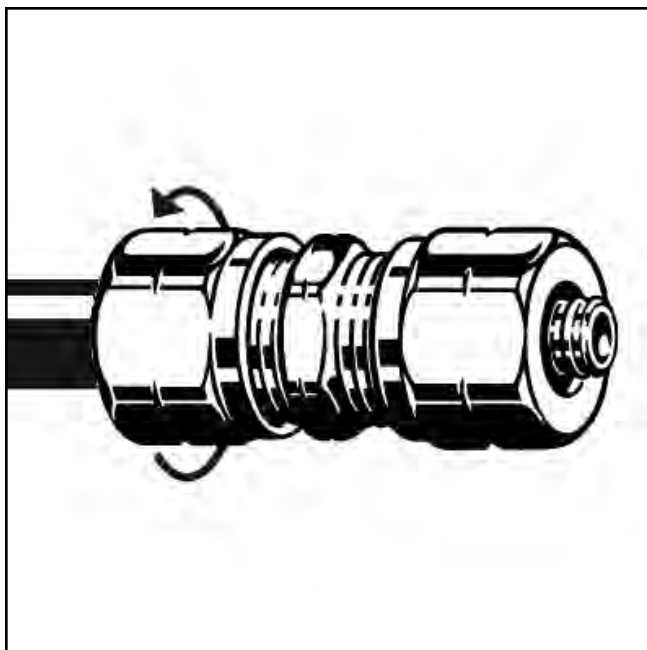

3. Placing a backer wrench on the hexagonal body of the fitting, then tighten compression nut to secure tubing. Retighten compression nut after 30 minutes.

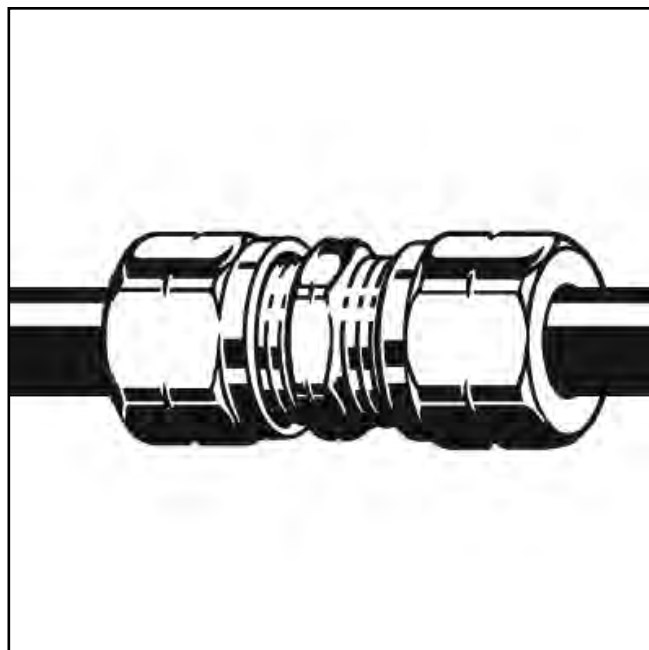

4. With backer wrench still in place, tighten the remaining compression nut to secure tubing. Retighten compression nut after 30 minutes.

MAKING A COMPRESSION CONNECTION - APPENDIX C

Follow these steps each time you make a 5/16" - 5/8" compression connection.

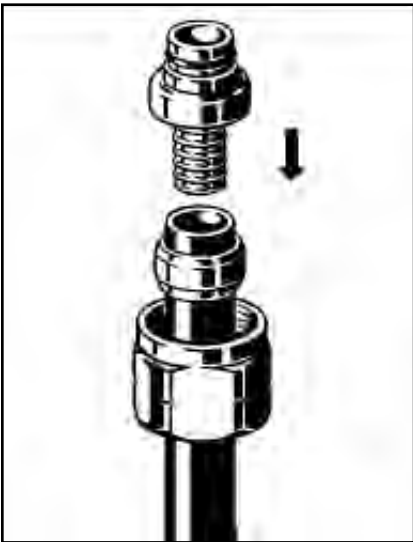

1. Square off end of tubing. Slide compression nut up tubing and slip brass ferrule over tubing.

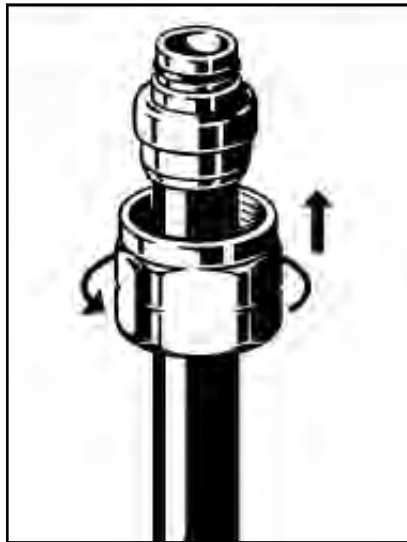

2. Slide tubing over end of SVC adapter, pushing it on fully until tubing is flush with shoulder of fitting.

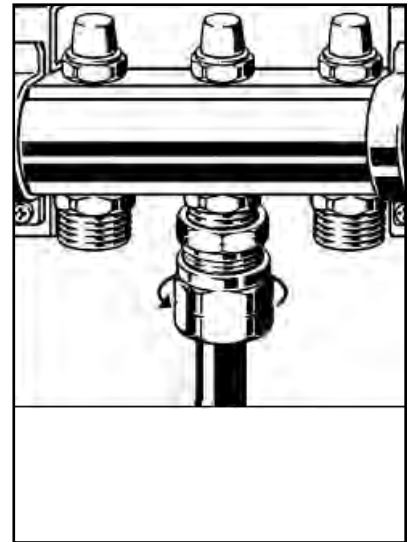

3. Insert SVC adapter into seat (manifold or other fitting) and tighten compression nut with wrench. Slightly retighten compression nut after 30 minutes.

TOOL LIST - APPENDIX D

• Installation (Power Tools) •

1. Radial Arm Chop Saw (12-inch recommended) optional sliding arm recommended also (less than 12-inch won't chop through the 7-inch ACPs or the 10-inch panels completely)
2. Skill Saw or Portable Table Saw - for ripping down panels
3. Staple Gun with hose and compressor (7/16"-1/2" crown by 1-1/4" or 1-1/2") staples
4. Alternative to the staple gun is a stand-up screw gun with self-feeding 1-1/4" to 1-3/4" screws (depending upon the application)
5. Battery-operated screw gun - for clips, touchups, hanging manifolds and blocks to hold tubing down at floor penetration
6. Drill with bit kit - hole saw kit
7. Saw - used for opening base of wall or cutting through plates to run multi-tubing lines through

• Installation (Hand Tools) •

1. Tape Measure (recommended one per person)
2. Chalk Line
3. Utility Knives - cutting aluminum sheets and nipping corners
4. Hammer - hammering down staples that were not fully embedded, miscellaneous uses
5. Rubber Mallet
6. Caulking Gun
7. Tubing Cutter
8. Chisel - to clean up floor penetration holes to create a ramp-like drop
9. Adjustable Wrench

• Pre/Post Installation •

1. Shop-Vac - for cleaning out grooves before silicone and tubing are installed
2. Broom - pre-installation cleanup of areas
3. Ice Scraper - used to scrape up globs of plaster or other material that would obstruct panels to lay flat

• Miscellaneous •

1. Saw Horses - to make table for chop saw
2. Portable Lights
3. Extension Cords
4. Calculator (recommended)
5. Sharpie - marker allows for more visible markings on dusty floors or concrete
6. Knee Pads - recommended wearing when installing tubing into tracks
7. Decoiler

R-VALUE TABLE FLOOR COVERINGS - APPENDIX E

| | 1/8" | 1/4" | 3/8" | 1/2" | 5/8" | 3/4" | 7/8" | 1" |
|--------------------------------|------|------|------|------|------|------|------|------|
| Building Board | | | | | | | | |
| Gypsum or Plaster Board | 0.11 | 0.23 | 0.32 | 0.45 | 0.56 | 0.68 | 0.79 | 0.90 |
| Plywood | 0.16 | 0.31 | 0.47 | 0.62 | 0.77 | 0.93 | 1.09 | 1.24 |
| Particleboard, low density | 0.18 | 0.35 | 0.53 | 0.71 | 0.88 | 1.06 | 1.23 | 1.41 |
| Particleboard, medium density | 0.13 | 0.27 | 0.40 | 0.53 | 0.66 | 0.80 | 0.93 | 1.06 |
| Particleboard, high density | 0.11 | 0.21 | 0.32 | 0.43 | 0.53 | 0.64 | 0.74 | 0.85 |
| Waferboard | 0.20 | 0.40 | 0.60 | 0.80 | 0.99 | 1.19 | 1.39 | 1.59 |
| Wood subfloor | 0.16 | 0.31 | 0.47 | 0.62 | 0.78 | 0.93 | 1.09 | 1.24 |
| Cement board | 0.03 | 0.06 | 0.09 | 0.12 | 0.15 | 0.18 | 0.21 | 0.24 |
| Tile | | | | | | | | |
| Ceramic Tile | 0.02 | 0.03 | 0.05 | 0.07 | 0.08 | 0.10 | 0.12 | 0.13 |
| Marble | 0.01 | 0.01 | 0.02 | 0.03 | 0.03 | 0.04 | 0.04 | 0.05 |
| Granite | 0.01 | 0.02 | 0.03 | 0.04 | 0.05 | 0.06 | 0.07 | 0.08 |
| Slate | 0.01 | 0.03 | 0.04 | 0.05 | 0.06 | 0.08 | 0.09 | 0.10 |
| Linoleum or Vinyl | 0.05 | 0.10 | 0.15 | 0.20 | 0.25 | 0.30 | 0.35 | 0.40 |
| Rubber, hard | 0.12 | 0.24 | 0.36 | 0.48 | 0.60 | 0.72 | 0.84 | 0.96 |
| Cork Tile | 0.28 | 0.56 | 0.84 | 1.12 | 1.40 | 1.68 | 1.96 | 2.24 |
| Carpet Pad | | | | | | | | |
| Waffled Sponge Rubber | 0.20 | 0.41 | 0.61 | 0.81 | 1.01 | 1.22 | 1.42 | 1.62 |
| Synthetic Jute | 0.43 | 0.86 | 1.28 | 1.71 | 2.14 | 2.57 | 2.99 | 3.42 |
| Bonded Urethane, 4 lb Density | 0.52 | 1.05 | 1.57 | 2.09 | 2.61 | 3.14 | 3.66 | 4.18 |
| Bonded Urethane, 8 lb Density | 0.55 | 1.10 | 1.65 | 2.20 | 2.75 | 3.30 | 3.85 | 4.40 |
| Prime Urethane, 2.2 lb Density | 0.54 | 1.08 | 1.61 | 2.15 | 2.69 | 3.23 | 3.76 | 4.30 |
| Carpet | | | | | | | | |
| Acrylic Level Loop | 0.52 | 1.04 | 1.56 | 2.08 | 2.60 | 3.12 | 3.64 | 4.16 |
| Acrylic Level Loop w/Foam Back | 0.51 | 1.02 | 1.53 | 2.04 | 2.55 | 3.06 | 3.57 | 4.08 |
| Acrylic Plush | 0.43 | 0.86 | 1.29 | 1.72 | 2.15 | 2.58 | 3.01 | 3.44 |
| Polyester Plush | 0.48 | 0.96 | 1.44 | 1.92 | 2.40 | 2.88 | 3.36 | 3.84 |
| Nylon Level Loop | 0.68 | 1.36 | 2.04 | 2.72 | 3.40 | 4.08 | 4.76 | 5.44 |
| Nylon Plush | 0.26 | 0.52 | 0.78 | 1.04 | 1.30 | 1.56 | 1.82 | 2.08 |
| Nylon Shag | 0.27 | 0.54 | 0.81 | 1.08 | 1.35 | 1.62 | 1.89 | 2.16 |
| Nylon Saxony | 0.44 | 0.88 | 1.32 | 1.76 | 2.20 | 2.64 | 3.08 | 3.52 |
| Wool Plush | 0.55 | 1.10 | 1.65 | 2.20 | 2.75 | 3.30 | 3.85 | 4.40 |
| Hardwood | | | | | | | | |
| Ash | 0.15 | 0.30 | 0.45 | 0.60 | 0.75 | 0.90 | 1.05 | 1.20 |
| Beech | 0.12 | 0.24 | 0.36 | 0.48 | 0.60 | 0.72 | 0.84 | 0.96 |
| Cherry | 0.15 | 0.30 | 0.45 | 0.60 | 0.75 | 0.90 | 1.05 | 1.20 |
| Elm | 0.14 | 0.28 | 0.42 | 0.56 | 0.70 | 0.84 | 0.98 | 1.12 |
| Maple | 0.13 | 0.26 | 0.39 | 0.52 | 0.65 | 0.78 | 0.91 | 1.04 |
| Oak | 0.15 | 0.30 | 0.45 | 0.60 | 0.75 | 0.90 | 1.05 | 1.20 |
| Cedar | 0.23 | 0.46 | 0.69 | 0.92 | 1.15 | 1.38 | 1.61 | 1.84 |
| Fir | 0.15 | 0.30 | 0.45 | 0.60 | 0.75 | 0.90 | 1.05 | 1.20 |
| Hemlock | 0.18 | 0.36 | 0.54 | 0.72 | 0.90 | 1.08 | 1.26 | 1.44 |
| Pine | 0.20 | 0.40 | 0.60 | 0.80 | 1.00 | 1.20 | 1.40 | 1.60 |
| Redwood | 0.20 | 0.40 | 0.60 | 0.80 | 1.00 | 1.20 | 1.40 | 1.60 |
| Spruce | 0.20 | 0.40 | 0.60 | 0.80 | 1.00 | 1.20 | 1.40 | 1.60 |
| Engineered Flooring | | | | | | | | |
| Laminated Parquet Flooring | 0.11 | 0.23 | 0.34 | 0.45 | 0.57 | 0.68 | 0.79 | 0.91 |



SUPPLY WATER TEMPERATURE/BTU OUTPUT CHARTS - APPENDIX F

Climate Panel 7" Above Subfloor

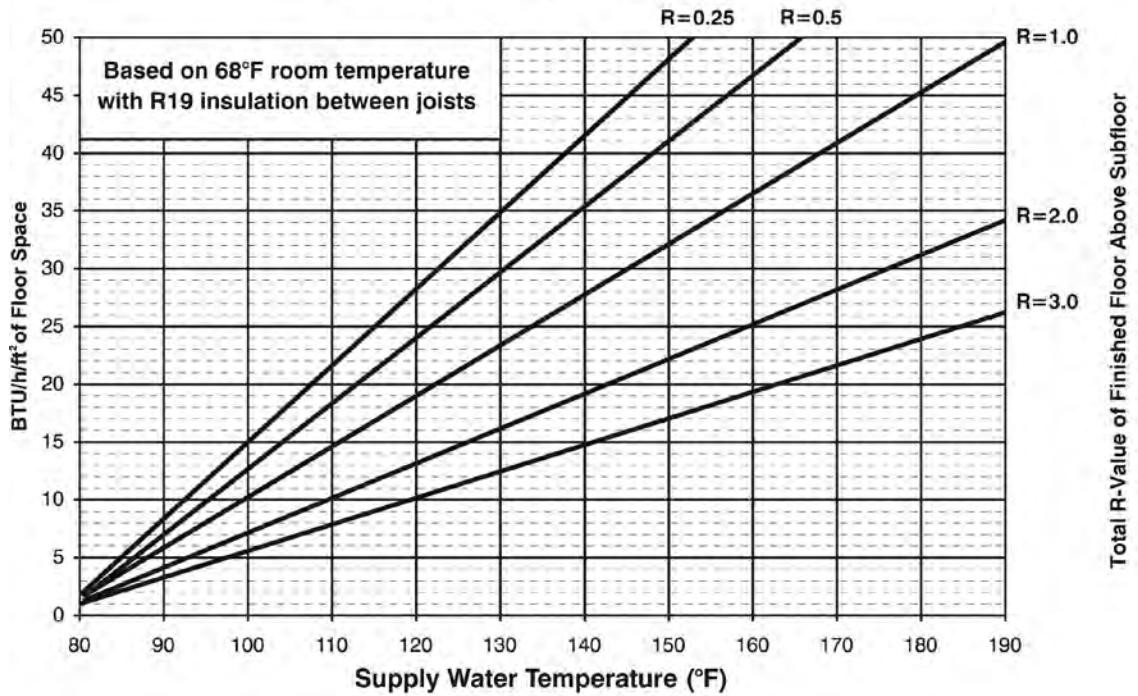

Climate Panel 10" Above Subfloor

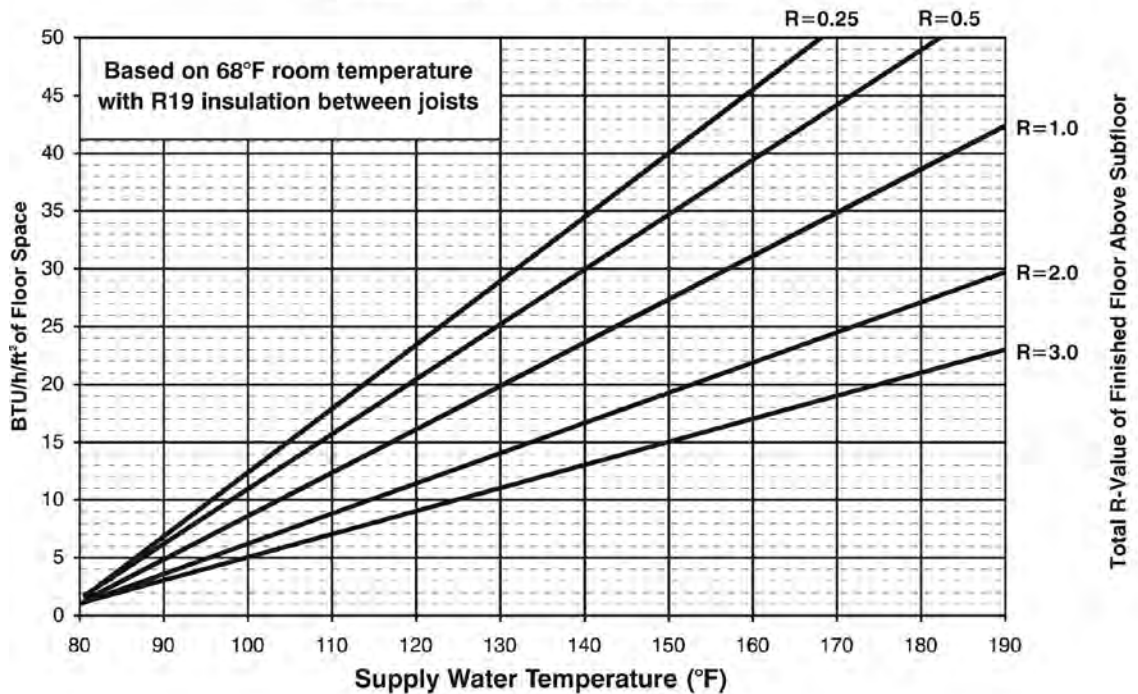

SUPPLY WATER TEMPERATURE/BTU OUTPUT CHARTS - APPENDIX F

Climate Panel 7" in the Wall

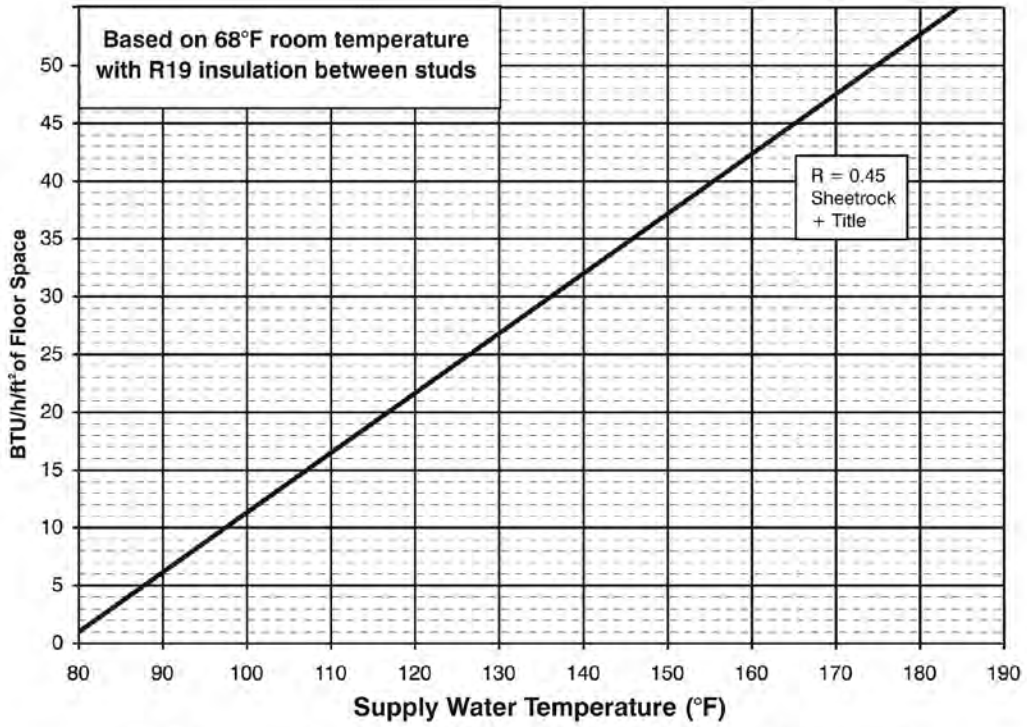

MAKING A MATERIAL LIST - APPENDIX G

Climate Panel Material Worksheet

Use the first worksheet to select the material for the installation of the Climate Panel system. Then, select the appropriate worksheet below to create a piping and control material list. These charts are intended for conceptual purposes; there may be variations in each job.

| Material | Net Heated Area | Multiplier | Estimated Amount |
|----------------------|-----------------|------------|------------------|
| 7" Panels | | 0.4 | |
| 7" ACPs | | 0.07 | |
| 10" Panels | | 0.3 | |
| 10" ACPs | | 0.05 | |
| U-Turns | | 0.04 | |
| Tubing (7" Spacing) | | 1.9 | |
| Tubing (10" Spacing) | | 1.4 | |
| Groove Tube | | 0.02 | |
| Screws | | 4.0 | |
| Staples | | 5.4 | |

Piping and Controls Material Worksheet

One-room application material worksheet:

| Material List | |
|--------------------------------------|----------|
| Products | Quantity |
| Mixing Station | |
| Actuator | |
| 1-1/4" Stainless Manifold, # Outlets | |
| Basic Heating Control | |
| Indoor Sensor | |
| FostaPEX | |
| Press Adapters | |
| Compression PEX Adapters | |

Multiple-room application material worksheet:

| Material List | |
|--------------------------------------|----------|
| Products | Quantity |
| Mixing Station | |
| Advanced Heating Control | |
| Basic Heating Control | |
| Actuator | |
| 1-1/4" Stainless Manifold, # Outlets | |
| Zone Control | |
| Thermostat | |
| Powerhead | |
| FostaPEX | |
| Press Adapters | |
| Compression PEX Adapters | |

NOTES



NOTES

Professional products, service, and training for professional contractors



Rely on Viega for the most complete line of high-tech/
high-quality plumbing, heating and snow melting
systems available today ... plus the most comprehensive
customer field support in the industry.

Dedicated to education, Viega has been recognized
by industry professionals as offering some of the most
innovative, informative and interactive training courses.
We have a comprehensive list of sessions in a variety
of forms from one-day workshops to rigorous three-day
programs. Call to receive our complete course catalog.



ProPress® System

Flameless
copper joining
technology.



ProPressG™ System

Flameless
copper fuel
gas joining
technology.



PureFlow® Systems

Flexible
PEX tubing
plumbing
technology.



ProRadiant™ Systems

Comfortable,
efficient heating
technology.



S-no-Ice® System

Snow and
ice melting
technology.



Viega

301 N. Main, 9th Floor, Wichita, KS 67202
Phone: 1-800-976-9819 Fax: 1-800-976-9817
www.viega.com • service@viega.com