

Climate Trak[®] Heating System

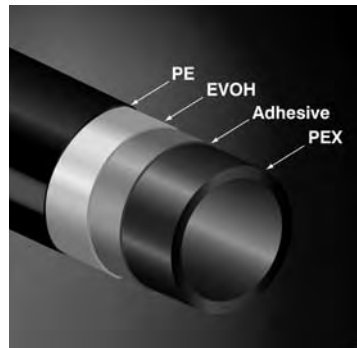

Installation Manual



February 2009



Disclaimer: Systems should be protected from freezing at all times. Proper insulation or glycol mixture may be needed in system if not used for an extended period of the heating season.

Working with Viega is the perfect solution.

Viega researches, develops, and produces complete system solutions for contractors in the technical building installation business. The components are produced at our plants or are supplied exclusively by the finest quality manufacturers. Each of our systems is developed in-house and tested under stringent quality control conditions to guarantee safety and efficient operation.

An international company with a national commitment.

Viega recognizes that many of the advances in our industry have their beginnings in Europe. However, that does not mean North America deserves anything less. Therefore, we have been the pioneer in combining technology from both sides of the Atlantic into the very best plumbing and heating systems for our customers.

Our goal is to remain in the forefront of the plumbing and heating industry well into the new century, and with our advanced products and a determination to remain the quality leader, we are convinced this accomplishment is well within our reach.

Welcome

By choosing to install a Climate Trak System, you have joined the ranks of heating system installers across the country who believe there is no substitute for quality.

Viega has a history of bringing high quality and innovative technology to the hydronic marketplace in North America.

It is the business of our engineers to research and develop complete systems that provide you the most effective and easy-to-use products available.

In the following pages, you will be guided through the system design, layout, installation and start-up of our Climate Trak System.

We look forward to sharing our history in the making with you.

Call 800-976-9819 for your local representative and wholesale location.

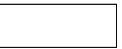

CONTENTS

1 System Overview

1.1 Application Benefits	4
--------------------------------	---

2 System Design

2.1 Calculating a Materials List	5
2.2 Heat Loss Calculations for Floor Heating Systems Using Radiant Wizard	6
2.3 Calculating the Supply Water Temperature	6
2.4 Calculating the Floor Surface Temperature	7
2.5 Calculating the Pressure Drop	8
2.6 Selecting a Circulator Pump	9

3 Climate Trak/Heat Transfer Plate System Installation

3.1 Pre-installation Tip Page	10
3.2 Clearing the Bays	11
3.3 Drilling Tubing Holes	12
3.4 Attaching the Traks/Plates	13
3.5 Installing the Tubing	14
3.6 Post-installation Tip Page	19

4 Piping and Controls

4.1 Mixing Station and Manifolds	20
4.2 Single and Multiple Temperature Schematics	21
4.3 Zone Wiring	24

5 System Start-up

5.1 Station and Actuator Installation	25
5.2 Purging and Pressure Testing the System	26
5.3 Adjusting the High Limit Kit	27
5.4 Initial Balancing	28

6 Finish Flooring

6.1 Choosing a Finished Floor	29
-------------------------------------	----

APPENDIX A

Making a Press Connection	30
---------------------------------	----

APPENDIX B

SVC Compression Coupling 3/8"- 5/8"	31
---	----

APPENDIX C

Recommended Tools for Installation	32
--	----

APPENDIX D

R-Value Table Floor Coverings	33
-------------------------------------	----

APPENDIX E

Supply Water Temperature/BTU Output Charts	34
--	----

APPENDIX F

Making a Materials List	37
-------------------------------	----

1. SYSTEM OVERVIEW

1.1 Application Benefits

Climate Traks and Heat Transfer Plates are designed for retrofit applications or in applications where the buildup above the subfloor is a concern. These types of applications are not the most efficient kind of radiant heating compared to systems such as Viega Climate Panel and Viega Snap Panel, but deliver the comfort of having warm floors and full radiant heating throughout the house. Both methods utilize ViegaPEX Barrier Tubing and attach directly to the underside of the subfloor. This is a fast, lightweight application to install and provides the comfort of radiant heat the homeowner is looking for.

Climate Trak:

1. Heavier aluminum than the Heat Transfer Plates
2. Fastest installation time (does not require Groove Tube)
3. Easiest to install (Traks and tubing are installed separately, so there is no struggling with the tubing while the fastening is being done)
4. Predrilled holes for ease of fastening with screws
5. Comes in 4' or 8' long Traks that also help with installation time
6. Snap-in groove for tubing maximizes contact between the aluminum and the PEX Tubing for efficient heat transfer



Heat Transfer Plates:

1. Made from thinner, more flexible aluminum than the Climate Traks
2. Comes in 20" long by 5" wide plates
3. Requires a small bead of Groove Tube down the channel where the tubing is run right before installation





2. SYSTEM DESIGN

2.1 Calculating a Materials List

Multipliers For Climate Traks			
Tubing OC	Plate Size	Tubing Multiplier	Trak Multiplier
6"	4'	2.2	.47
	8'		.23
8"	4'	1.7	.35
	8'		.18
9"	4'	1.5	.31
	8'		.16
12"	4'	1.1	.23
	8'		.12
16"	4'	.85	.18
	8'		.09
18"	4'	.75	.16
	8'		.08

Multipliers For Heat Transfer Plates		
Tubing OC	Tubing Multiplier	Plate Multiplier
6"	2.2	.93
8"	1.7	.70
9"	1.5	.62
12"	1.1	.47
16"	.85	.35
18"	.75	.31

Maximum Circuit Length		
	≤25 BTU/ft ²	26-35 BTU/ft ²
3/8"	300 ft.	250 ft.
1/2"	400 ft.	350 ft.

1. Calculate the total heated area.
2. Using the charts above and the total area, calculate the total number of Traks/Plates and amount of tubing needed for the job.
3. Using the circuit length chart, calculate the total number of circuits needed.

Example: Heated Area - 1,500 sq. ft.

Calculating Number of Traks

8' Climate Traks 8" O.C.

of Traks = 1,500 sq. ft. x .18

of Traks = 270

- Sold in packages of 20:

(round up to order 14 boxes)

Calculating Amount of Tubing

Amount of Tubing = 1,500 sq. ft. x 1.7

Amount of Tubing = 2,550 ft.

Calculating Number of Circuits (≤25 BTU/ft²)

Amount of Tubing = 2,550 ft.

2550 ft./400 ft. = 6.375

of 1/2" circuits = 7

2.2 Heat Loss Calculations for Floor Heating Systems Using Radiant Wizard®

The easy-to-use Radiant Wizard program will help calculate the heat loss of any residential building. Based on ASHRAE formulas, the Radiant Wizard will also perform a full, multi-temperature, room by room, detailed design while calculating a materials list and price for your system. A step-by-step user manual is provided with the

program to help you with the process. Available in the program is a full list of all Viega ProRadiant and PureFlow products, product instructions, specification sheets, manuals and catalogs. Once Radiant Wizard is installed on your computer, updating to the latest version is quick and easily accomplished online. Contact your local Viega District Manager to receive a copy of the Radiant Wizard program.



Climate Trak 8" Spacing BTU Output

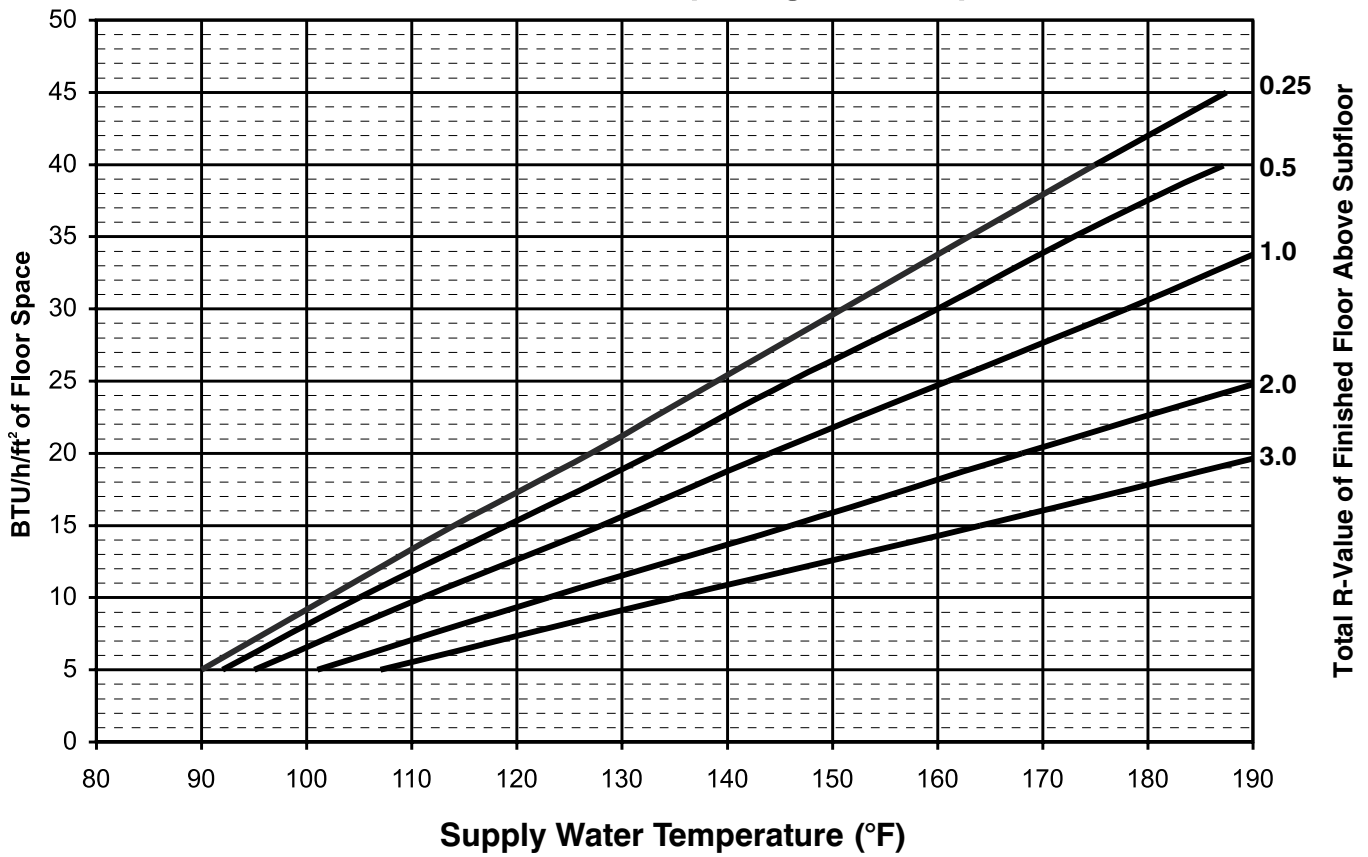

Based on 68°F room temperature with R19 insulation between joists

2.3 Calculating the Supply Water Temperature

Procedure:

1. Locate desired BTU output (from Radiant Wizard) on left vertical axis.

2. Follow to the right until you reach the selected total R-value curve.

3. Then move down to the horizontal axis and read the supply water temperature.

(For additional Climate Trak/Heat Transfer Plate BTU output charts, refer to Appendix E).

2.4 Calculating the Floor Surface Temperature

This chart shows the relation between room temperature and floor surface temperature for floor heating systems.

Procedure:

1. Locate desired output (from Radiant Wizard or other source) on left vertical axis.
2. Follow to the right until you reach the curve.
3. Then move down to the horizontal axis and read the ΔT between the room temperature and the floor surface temperature.
4. Add the room temperature and the ΔT to get the floor surface temperature.

Example:

Output needed: 25 BTU/h/ft²

Room temperature: 68°F

Temperature ΔT
(from chart): ~ 12°F

Floor surface temperature:
68°F + 12°F = 80°F

The floor surface temperature will be 80°F with 25 BTU/h/ft² output and 68°F room temperature.

Floor Surface Temperature Chart

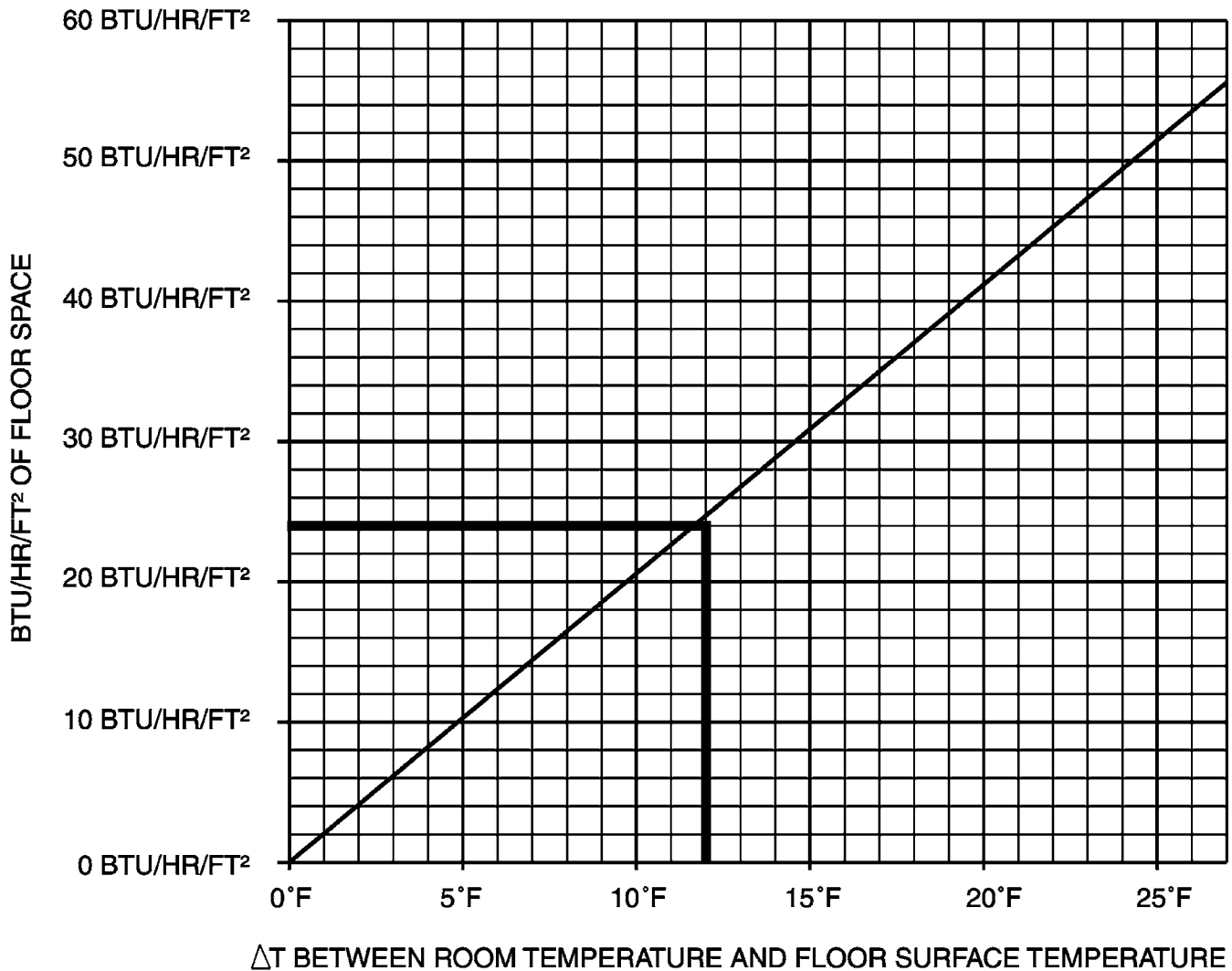

2.5 Calculating the Pressure Drop

In order to select the correct pump size for the system, the pressure drop must be calculated. Use the chart below to calculate the pressure drop.

Procedure:

1. Locate desired flowrate for one circuit on the left vertical axis (receive circuit flowrate from the Radiant Wizard program).
2. Follow to the right until you reach the selected tubing size.
3. Then move down to the horizontal axis and read the pressure drop in feet of head per foot of tubing.
4. Multiply pressure drop per foot by length of longest circuit.

ViegaPEX™ Barrier Tubing Data Table			
Nominal Size (in.)	Outside Diameter (in.)	Inside Diameter (in.)	Water Content (in.)
*5/16	0.430	0.292	0.004
3/8	0.500	0.350	0.005
1/2	0.625	0.475	0.009
5/8	0.750	0.574	0.014
3/4	0.875	0.671	0.018
1	1.125	0.862	0.030
1-1/4	1.375	1.053	0.045
1-1/2	1.625	1.243	0.063

*5/16" used in Climate Panel installation.

Example:

GPM through 1/2" PEX: 0.7 gpm

Pressure drop per foot: ~ .022 ft. of head / ft.

Total pressure drop: .022 x 350 total ft. = 7.7 ft. of head

Pressure Drop Chart

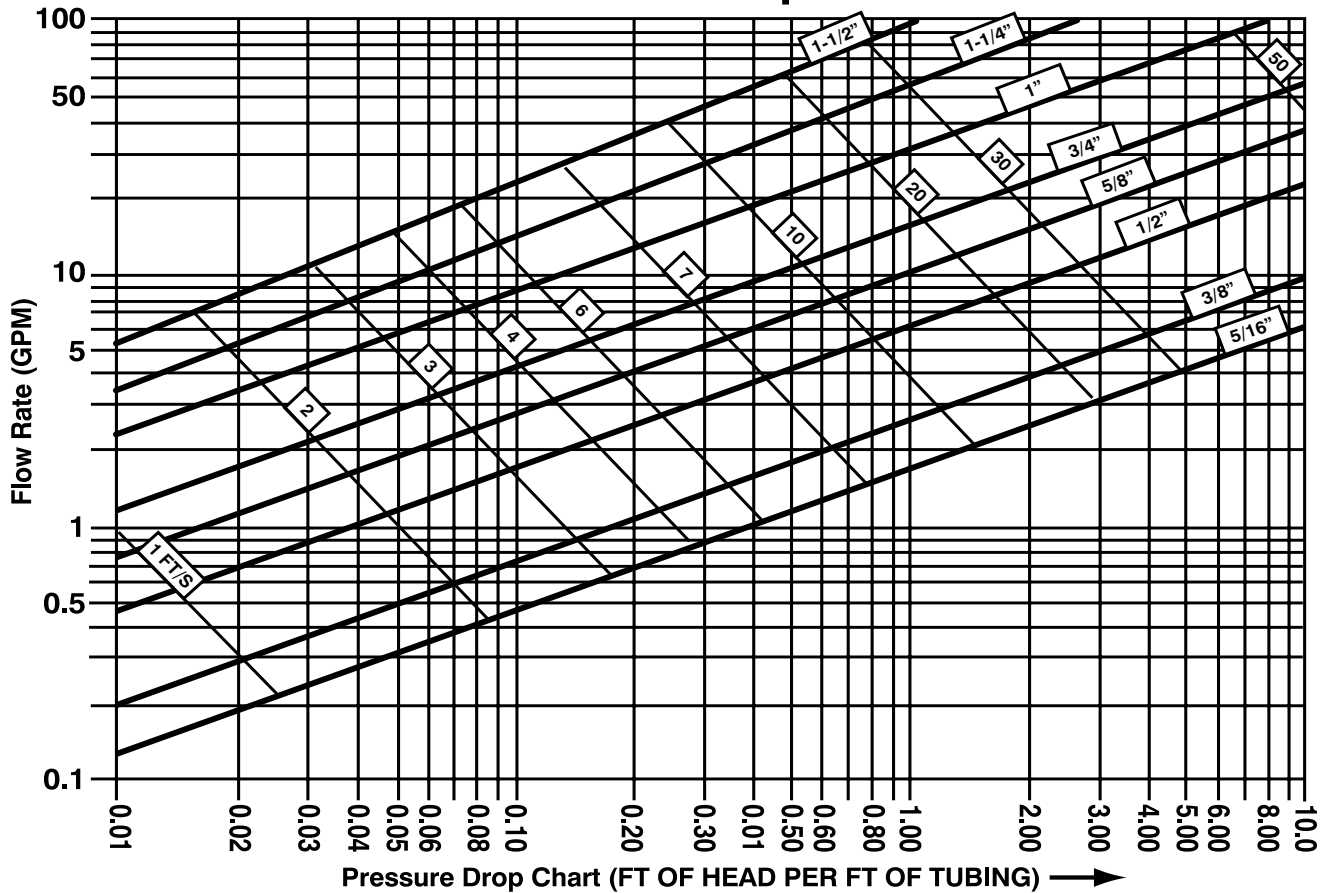

2.6 Selecting a Circulator Pump

The pump must have a capacity equal to the system flow rate and a head equal to the system pressure loss. These two system characteristics are the primary ones in selecting a pump. Flow rates come from the Radiant Wizard program. Pressure drop comes from section 2.5 (Calculating the Pressure Drop) or from the Radiant Wizard program. Remember that for pressure drop, use the highest pressure drop of all the circuits fed by their circulator. If the circulator can overcome that pressure drop, then it can overcome all the others.

Procedure

1. Locate the pressure drop on the left vertical axis.
2. Locate the total system flow rate on the bottom horizontal axis.
3. Follow to the intersection of both variables.
4. Select the pump with a curve higher than this point.

Example

Total GPM through 1/2" ViegaPEX Barrier:
5 GPM

Longest circuit pressure drop:
10 ft. of head

Pump selected: Low Head Pump

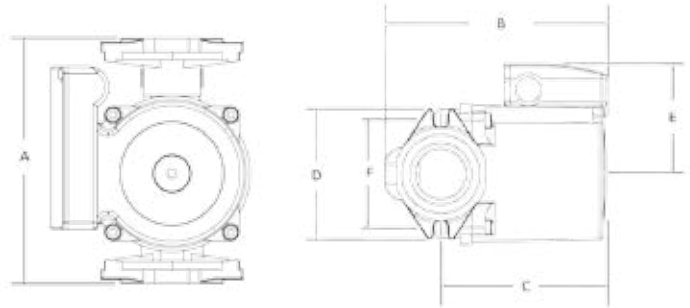

Stock Code	A	B	C	D	E	F
12126	6-1/2"	5-1/4"	4"	4-3/16"	3"	3-5/32"
12127	6-1/2"	6"	4-7/8"	3-1/2"	3-7/16"	3-5/32"

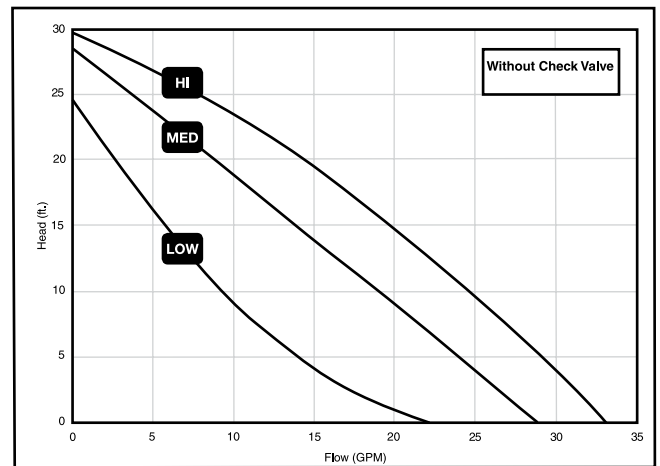
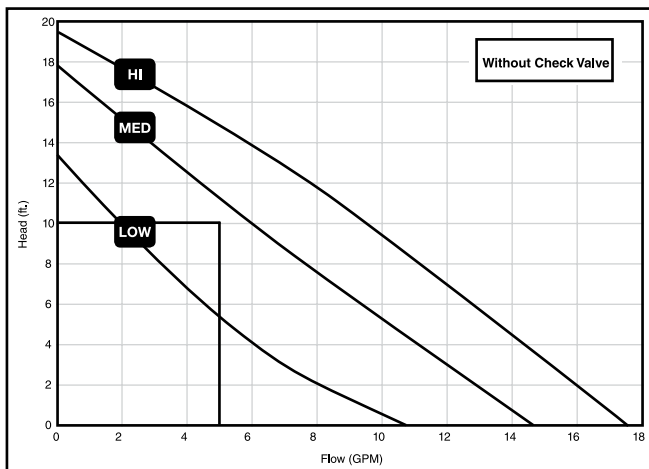

Stock Code	Speed	Amps	Watts	HP
12126	HI	0.75	87	1/25
	MED	0.66	80	1/25
	LOW	0.55	60	1/25

3. CLIMATE TRAK / HEAT TRANSFER PLATE SYSTEM INSTALLATION

3.1 Pre-Installation Tip Page

Place the Traks for the most even heat distribution.

Dimensions in drawing are based on standard 2" by 8", 2" by 10" or 2" by 12" floor joists on 16" centers. Adjust spacing as needed when using engineered joists or different spacing.

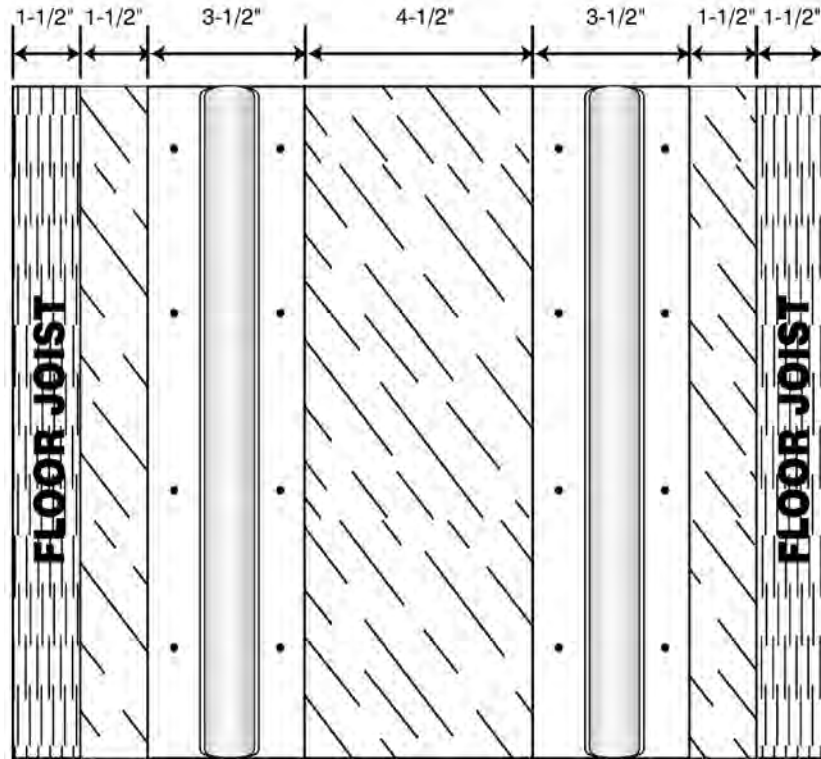

Avoiding Obstructions

It is important not to install the Traks around objects that will restrict the tubing from being installed into the Traks. In the example below, if the Traks were run on the inside of the dropping pipe, you would find that the tubing would be unable to be snapped in. This is why the Traks are shown going to the outside of the dropping pipe.

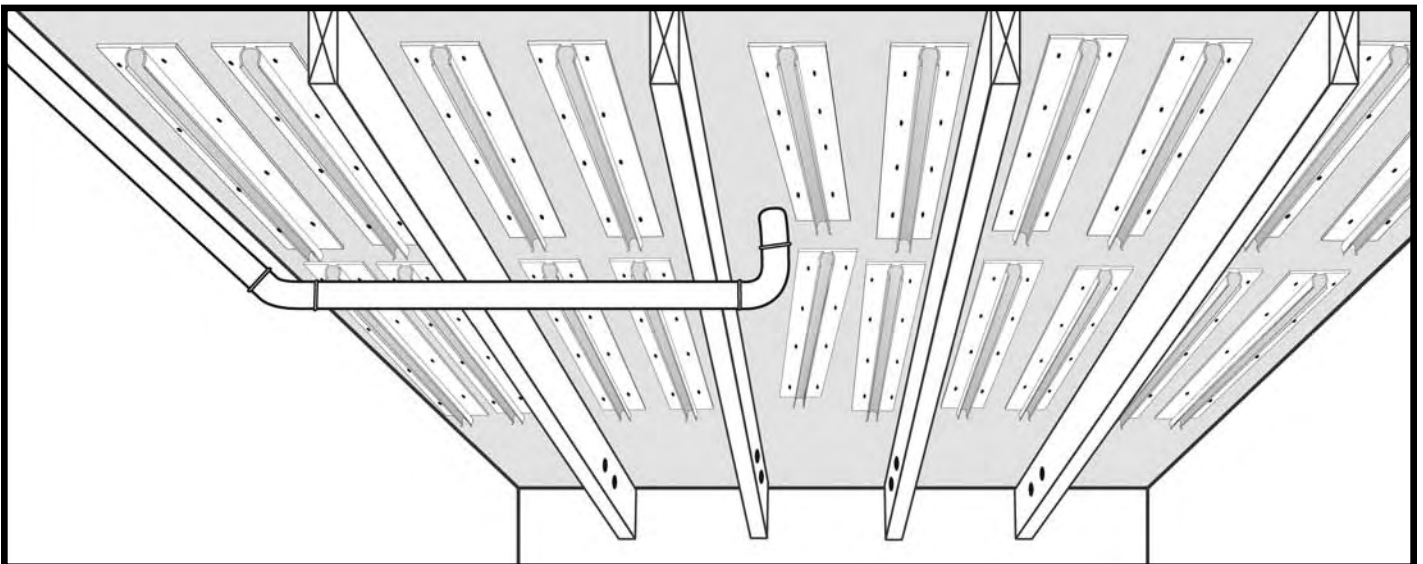

3.2 Clearing the Bays

If support crosses can be easily removed, take them out to clear bays for easier installation of the plates and Traks. If crosses are unable to be removed, DO NOT drop tubing below them and resume on the other side; install both plates and tubing above crosses so that no area is lost. Nails must also be removed from bays. Whether you cut them, grind them or carefully bend them over, be careful not to damage the finished floor above. (When cutting nails, be sure to wear safety glasses. )

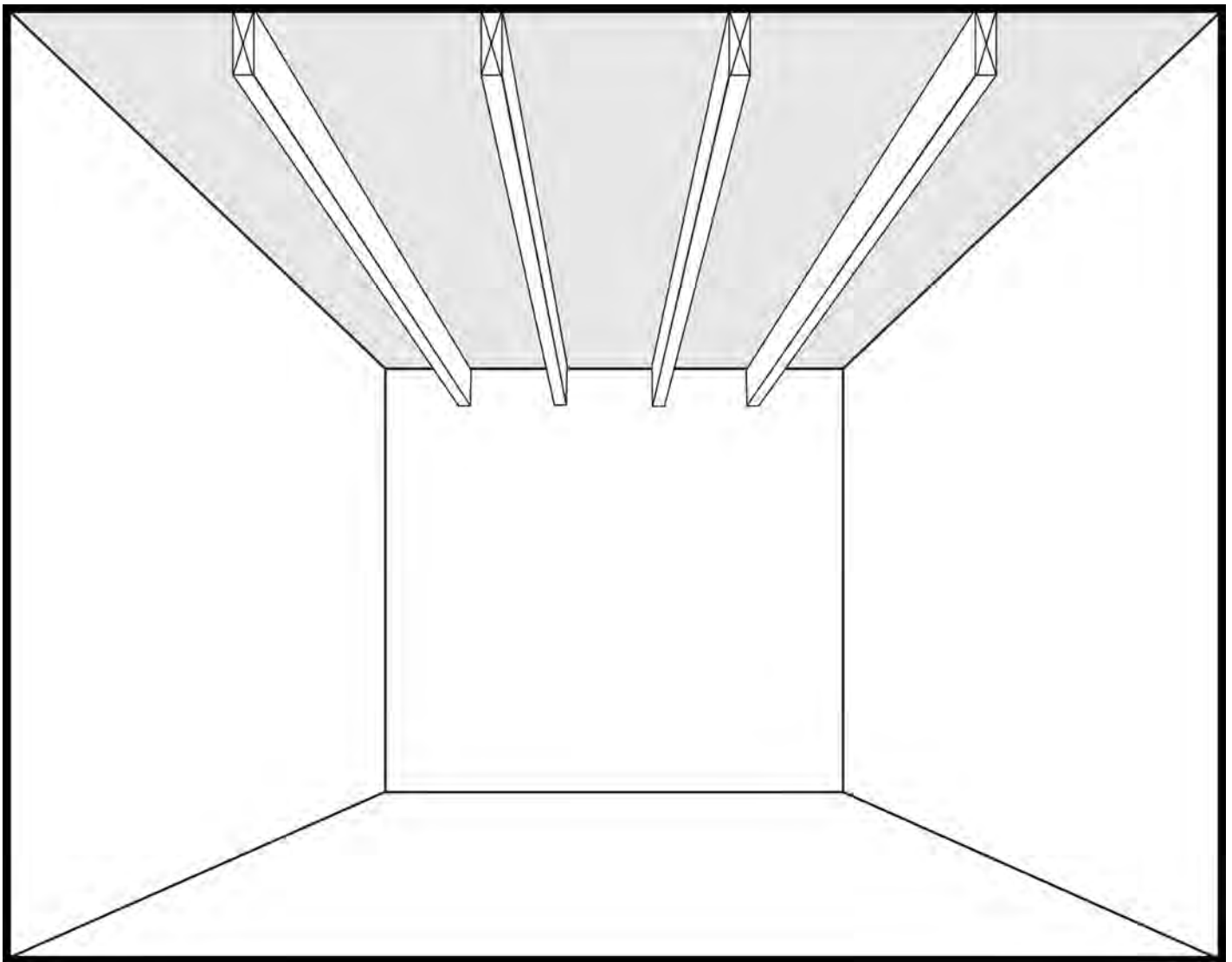

3.3 Drilling Tubing Holes

Determine where the manifold will be located, then from there, decide which end of the bays the tubing will be returning down. Use a right angle drill with a 1-1/4" bit to drill a series of holes through each floor joist. Be sure to keep holes at least 3" from the subfloor to avoid floor nails, although having the holes centered would be the best for structural strength.

Map out the circuits and determine which bays go to which circuits. Be careful not to exceed maximum circuit length for the size of tubing you are using (3/8" - 300 ft., 1/2" - 400 ft.).

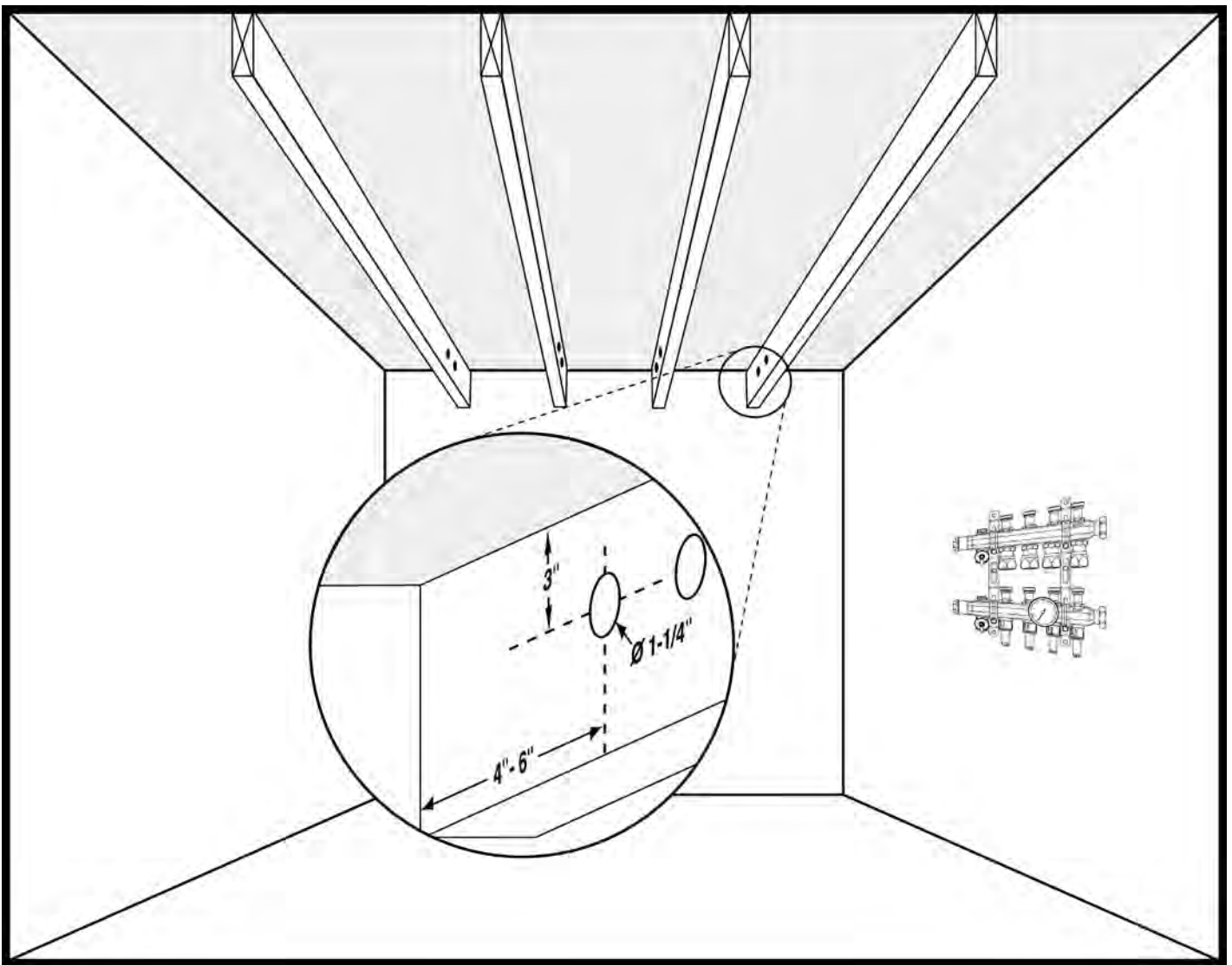

NOTE: Be sure to check with local building codes to ensure no structural damage will occur with drilling the joists.

3.4 Attaching the Traks/Plates

Start attaching the Traks via staples or zip screws (staples - 7/16" - 1/2" crown by 3/4" - 1", depending upon subfloor thickness; putting in 18-20 staples for an 8 ft. piece and 10-12 staples for a 4 ft. piece; zip screws 3/4" - 1", depending on subfloor thickness). Begin attaching Traks 8" - 10" from the closest hole that was drilled to allow ample room for tubing to turn. Continue to install Traks the entire length of the bay (or to where desired circuit ends) keeping the space in between Traks to around 1". Stop Trak installation 12" - 16" short of where you want circuit to end (i.e., wall, main beam, room above) to allow for a non-stressful loop. *When stapling up Traks, be sure to keep staple gun square to avoid staple deflection.*

Safety glasses and ear protection are recommended. 

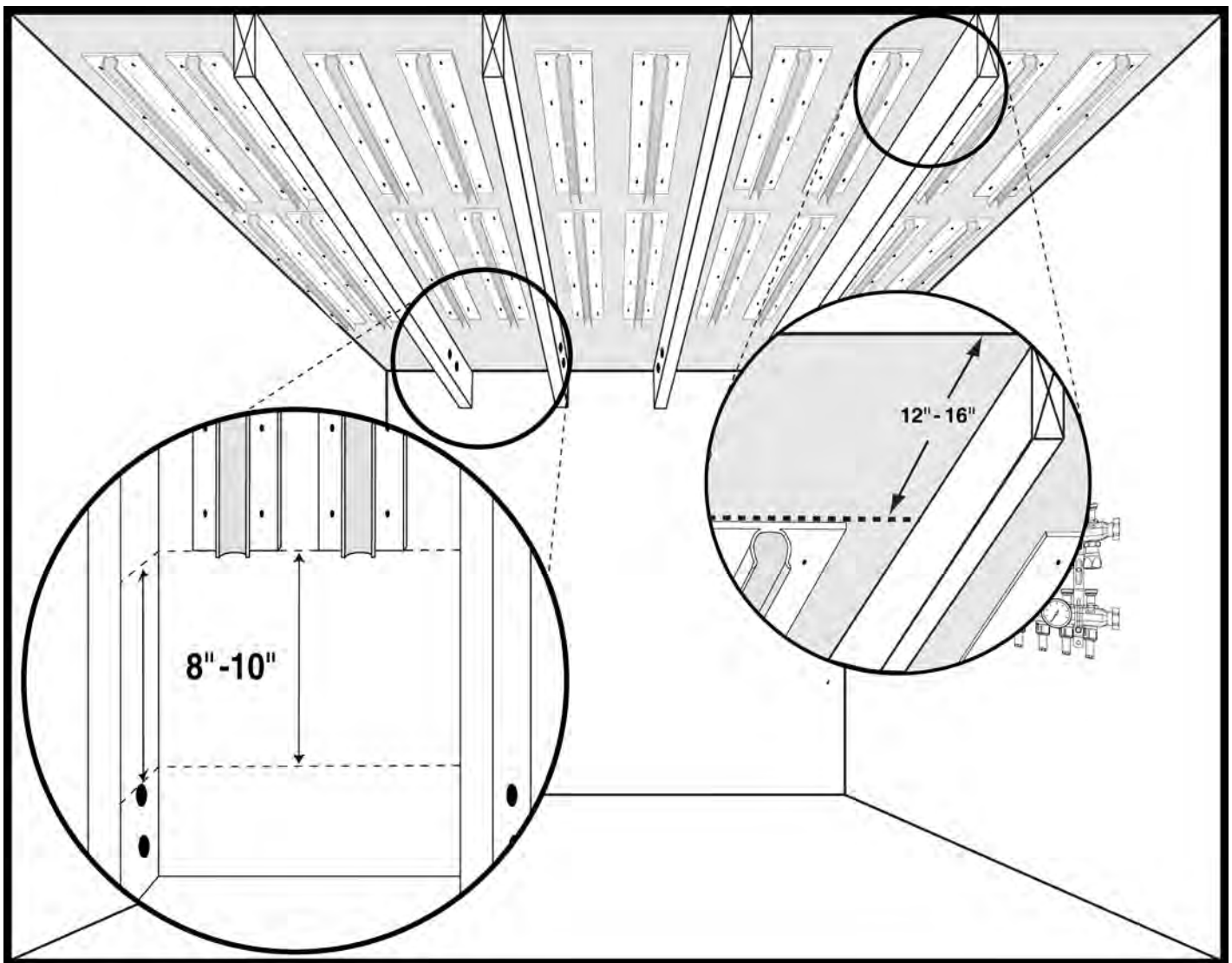

NOTE: Traks should be attached as flush as possible to the subfloor for best heat transfer.

NOTE: When Traks are cut, be sure to debur them to avoid any tubing damage.

3.5 Installing the Tubing

Begin to make non-stressful (teardrop) type loops for each of the bays, keeping loops small and manageable.

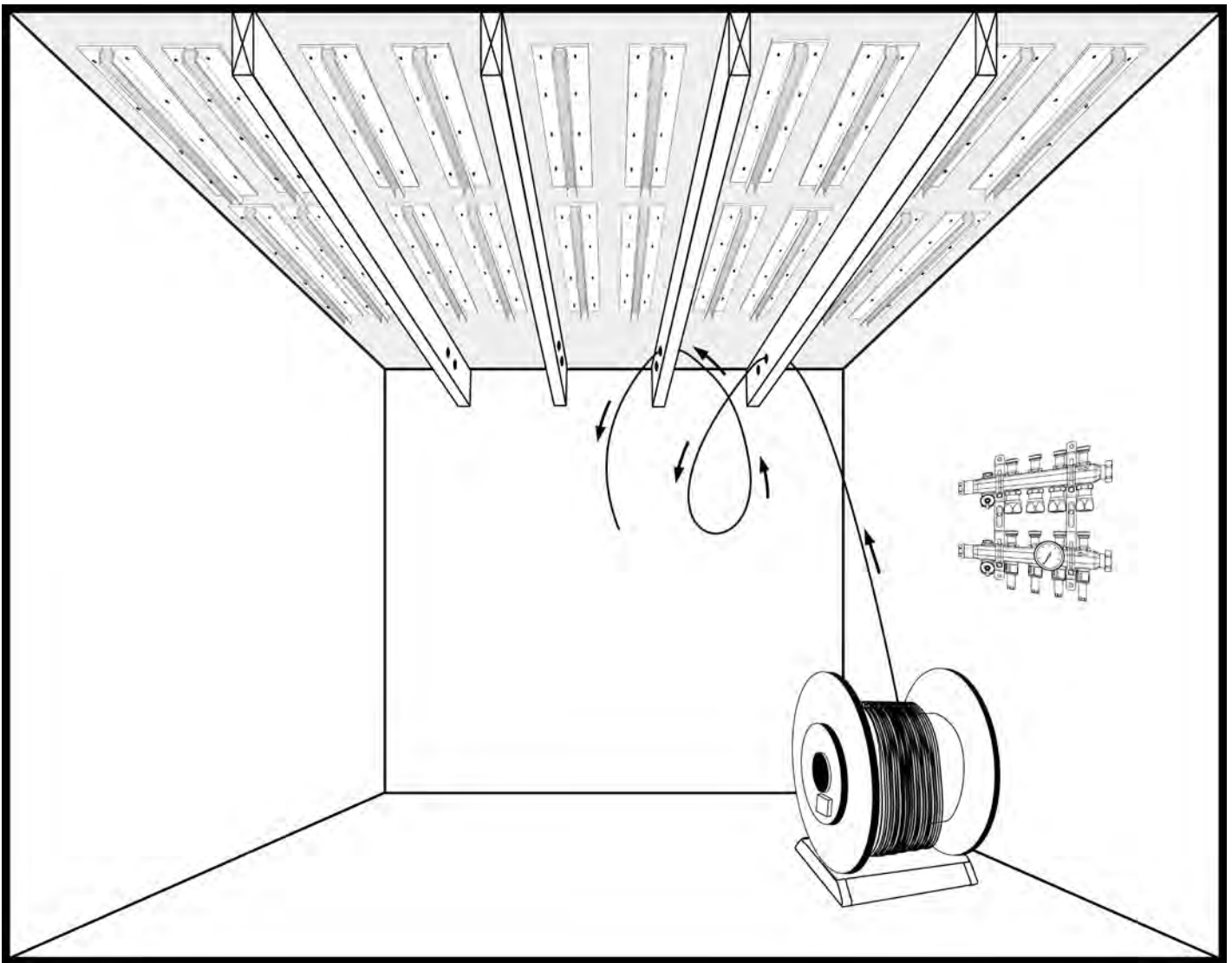

3.5 Installing the Tubing

Continue making the “teardrop” loops, being sure not to install any of the tubing into the Traks yet. Keep loops fairly small and manageable to prevent twisting while keeping the loops easy to transfer tubing through.

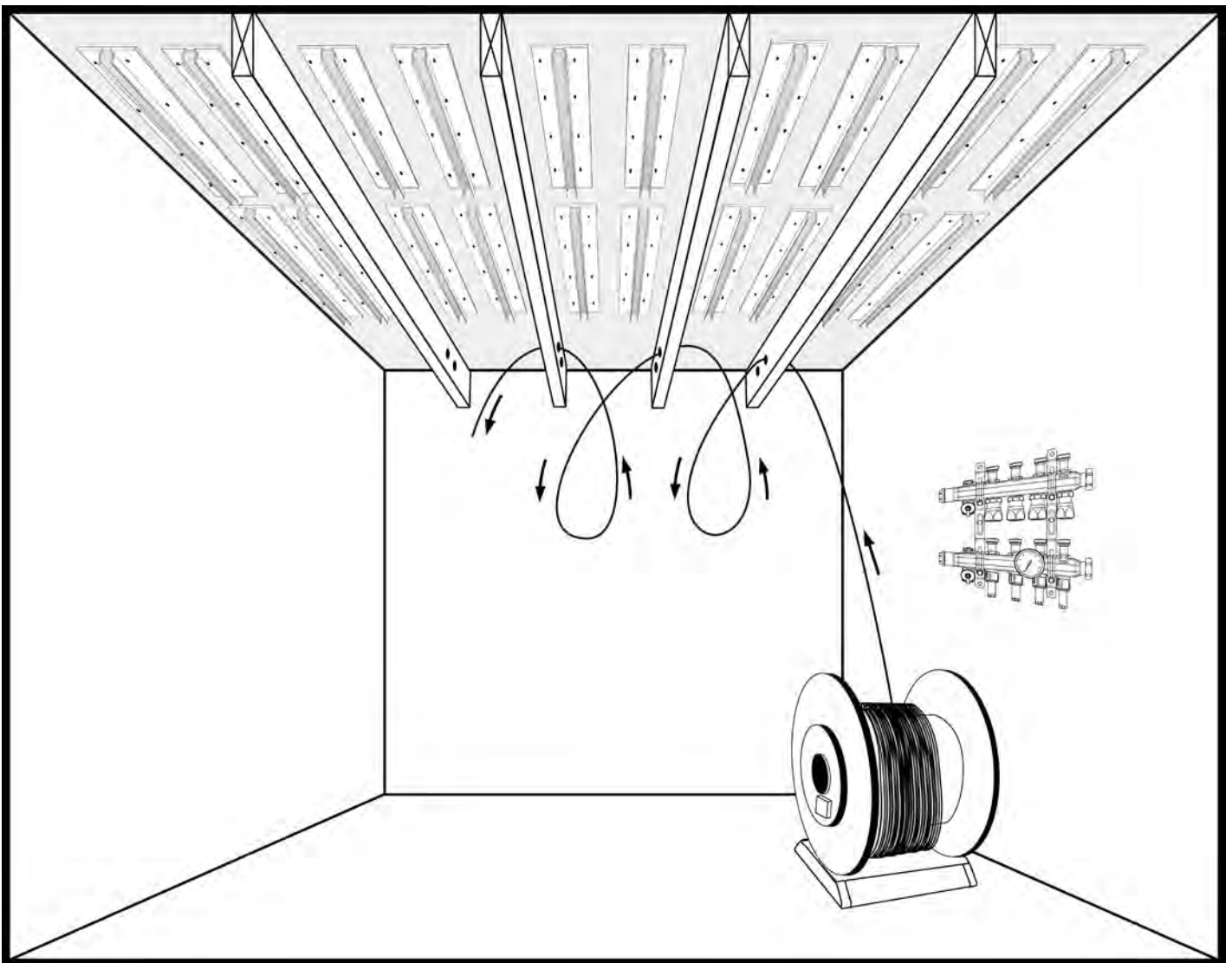

3.5 Installing the Tubing

Transfer tubing from the decoiler through loops until there is enough tubing to fill the final bay and make the run back to the manifold using the second set of drilled holes.

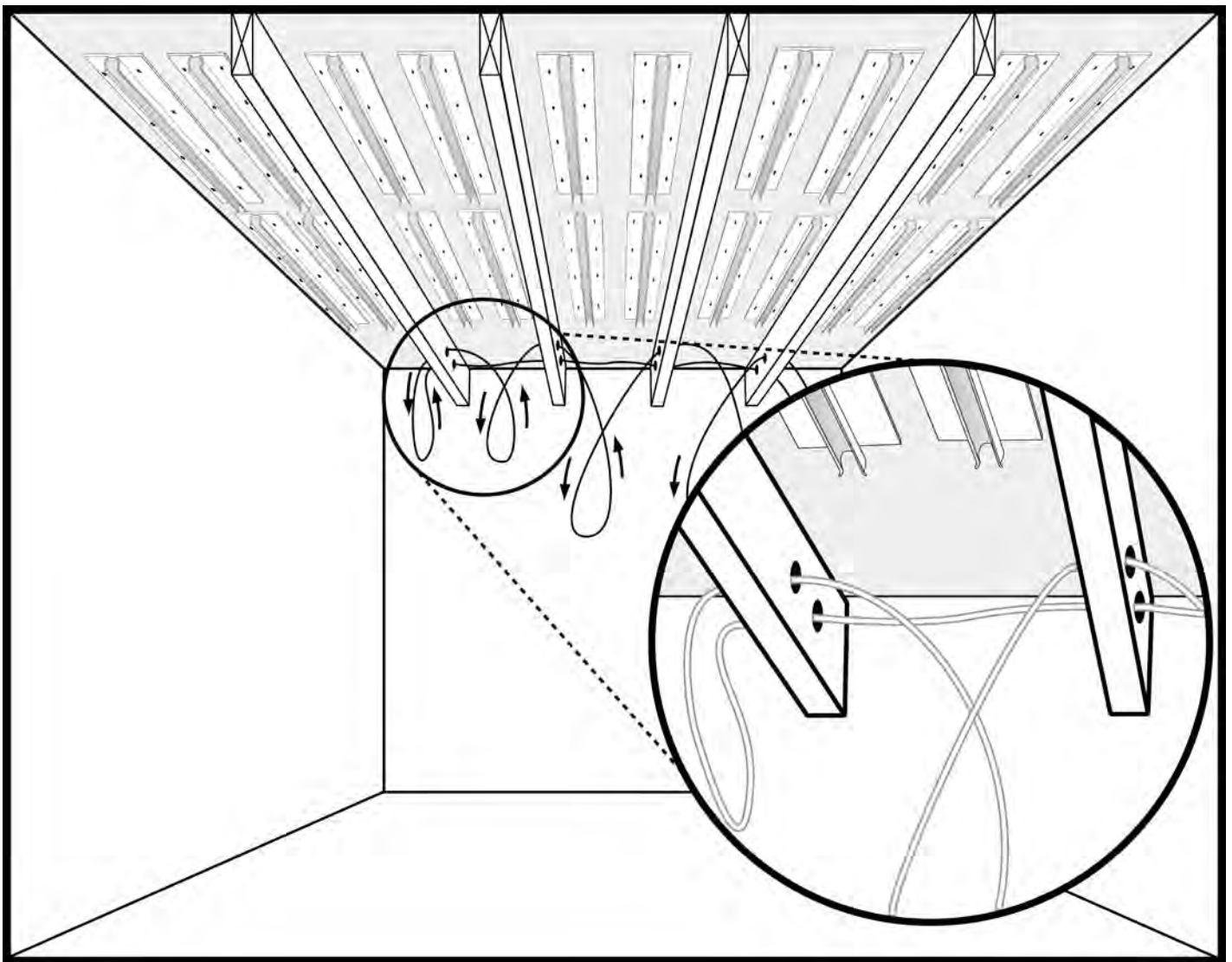

3.5 Installing the Tubing

Once the final bay is installed, transfer tubing from coil to fill next bay and so on.

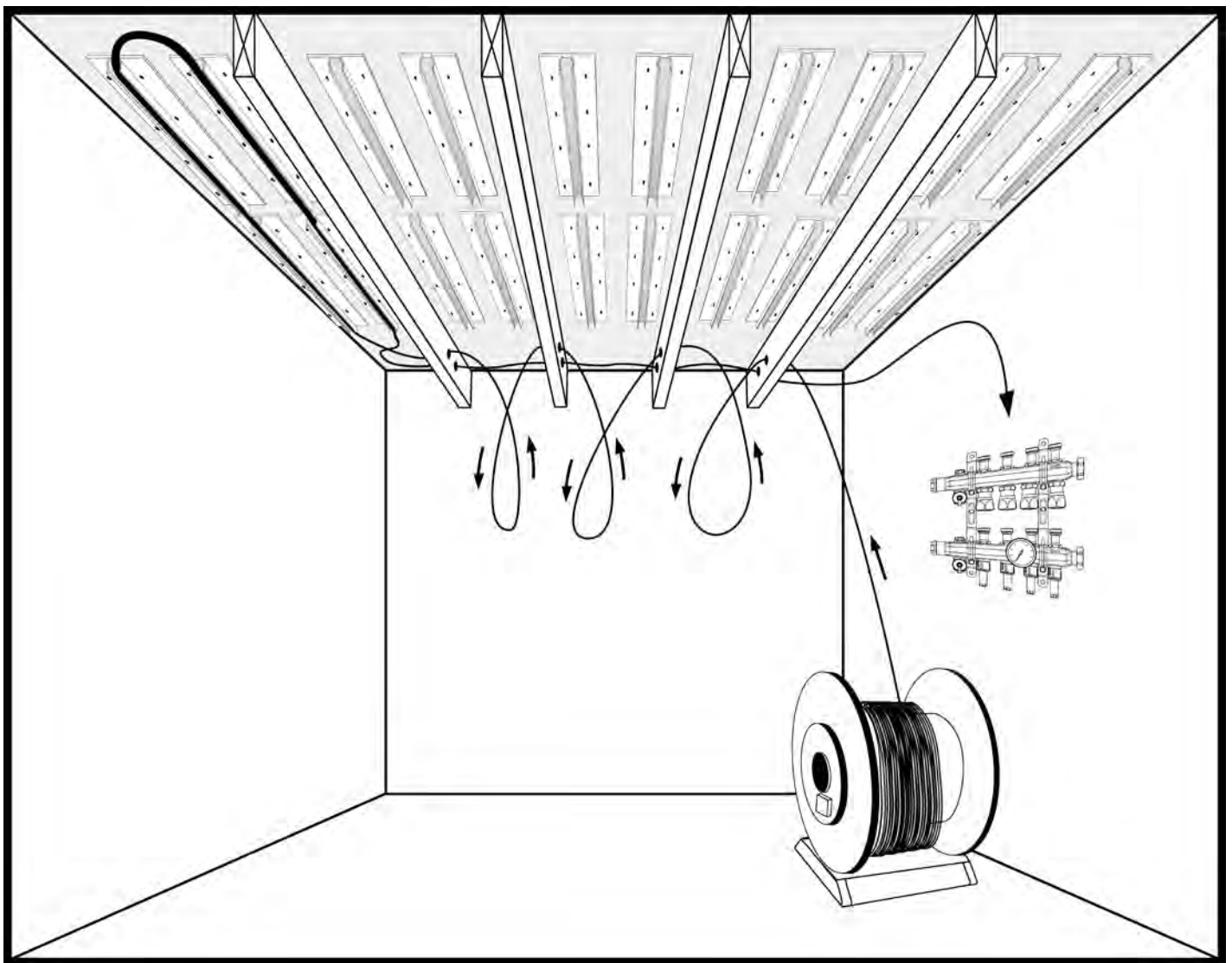

NOTE: Tubing can be installed into Traks using a rubber mallet or a palm hammer with a medium plastic tip.

3.5 Installing the Tubing

Continue transferring the tubing through the loops, finishing one bay at a time.

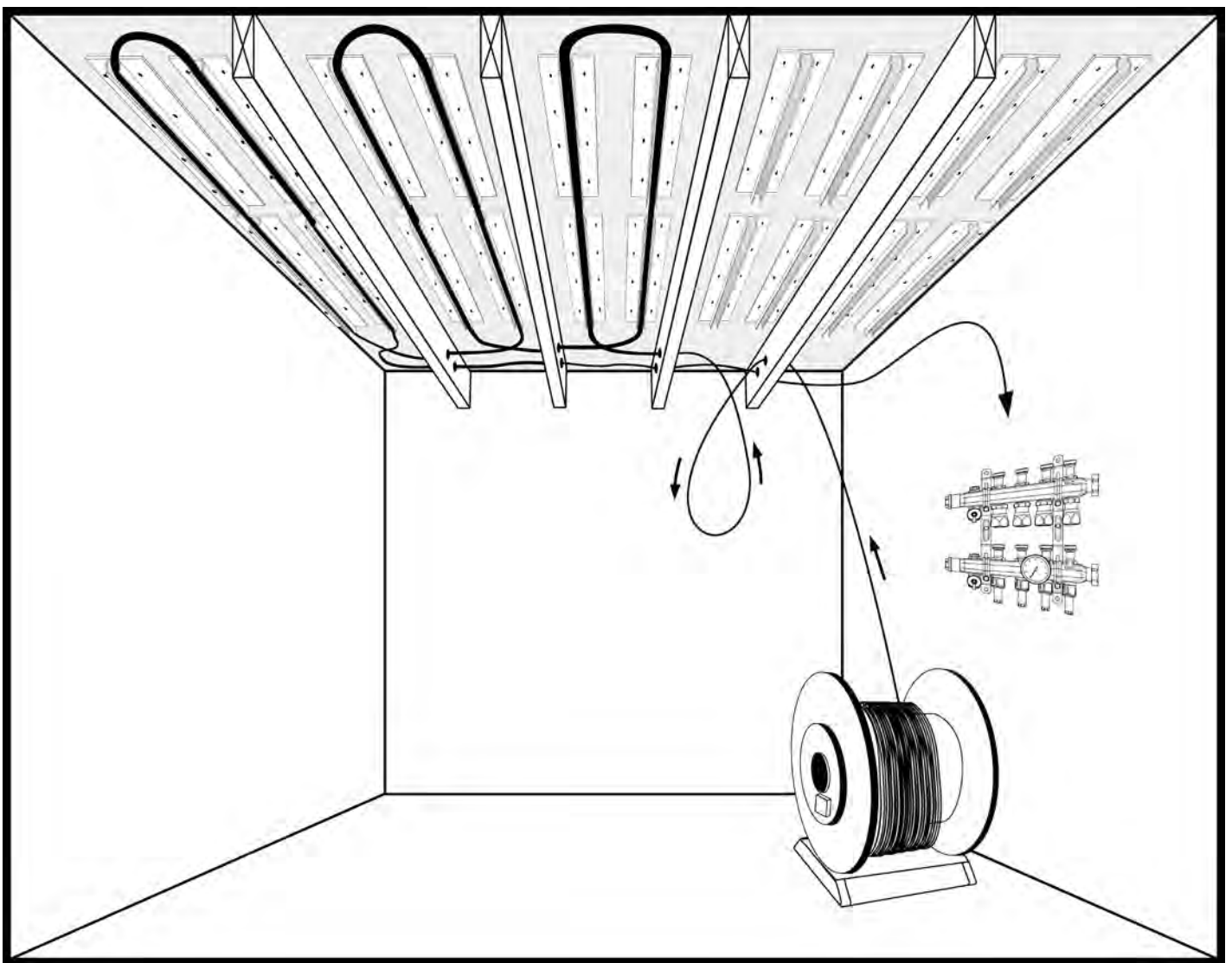

3.6 Post-installation Tip Page

Insulation

Insulation should always be used in a staple-up radiant installation. Ideally there should be a 1" - 2" air gap in between the insulation and the Traks/Plates.

However, the air gap should only be left if that space is considered a dead air space (absolutely no air current through it, whether it be from an outside wall, from below, or through holes in the subfloor).

To create a dead air space, begin by insulating the outside ends of the joist bays with a separate piece of insulation (insulation blocking) between the top of the foundation and the bottom of the subfloor to keep cold air from entering through sills and outside walls.

Any air current through this space will decrease the performance of the system and the insulation. By insulating outside walls, sealing any large gaps in the subfloor and ensuring that the insulation is tight against the joist, this will create a situation where the air gap is beneficial to the performance of the system.

If a dead air space is unable to be achieved, then the insulation should be pushed up lightly against the Traks/Plates.

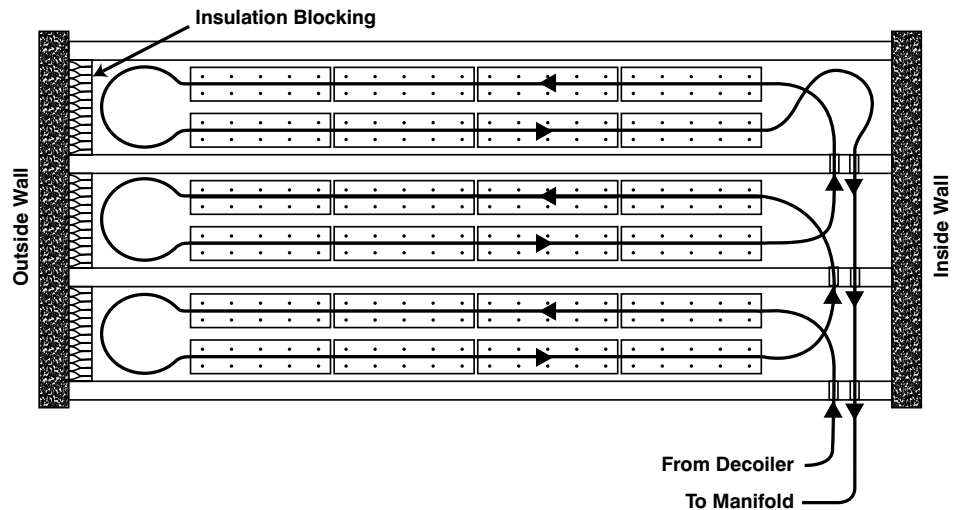
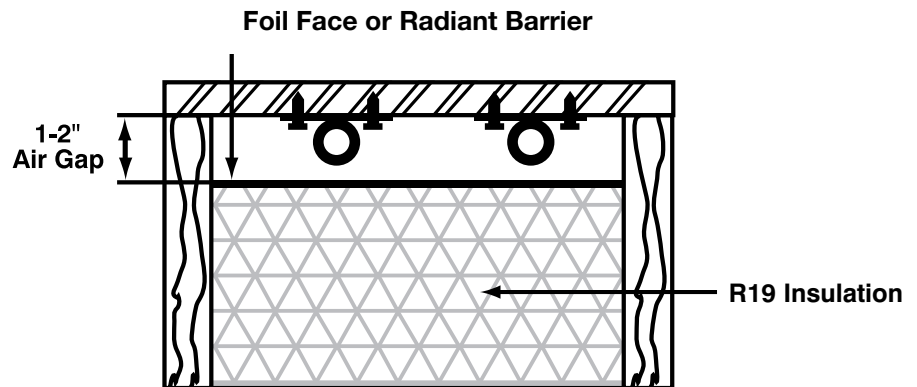

Note: When using expanding foam insulation on and around the PEX tubing, please contact the manufacturer of the foam or Viega for PEX compatibility issues. Some foams may cause excessive heat if installed improperly. This excessive heat may cause damage to the PEX.

4. PIPING AND CONTROLS

4.1 Mixing Station and Manifolds

In many applications either an Injection or Mixing Station can be used; however, because a staple-up system generally uses 10-20° higher water temperature, Viega recommends only using a Mixing Station with this type of application.

Mixing Station Includes

- 2 - Ball valves
- 1 - Pump (low, medium, high)
- 1 - Diverting valve with integrated high temp. limit
- 2 - 6-5/8" Spacing mounting brackets

Options

- Two position actuator
- Three position actuator

1-1/4" Stainless Manifold Includes

- 2 - 6-5/8" - Spacing brackets (for compact remote mounting)
- 2 to 12 - Outlets per header
- 2 to 12 - Balancing valves on supply header for flow adjustment from 0-2 GPM
- 2 to 12 - Shut-off valves on return header designed to receive powerheads (15061)
- Built-in purge valves and air bleeders
- 1-1/4" Union Connections
- 1" NPT removable end caps

Other Manifolds Available

- 1-1/4" Stainless Manifold Shut-Off/Balancing/Flow Meters
- 1-1/4" Stainless Manifold Valveless
- 1" Brass Manifold (when using the brass manifold, an accessory kit is needed for proper air elimination and purging)

Options

- Powerheads
- Circuit temperature gauges (used with Stainless Shut-Off/Balancing/Flow Meters only)
- SVC circuit flow meters
- SVC circuit ball valves
- Reducers for direct station attachment (needed for stainless manifolds only)

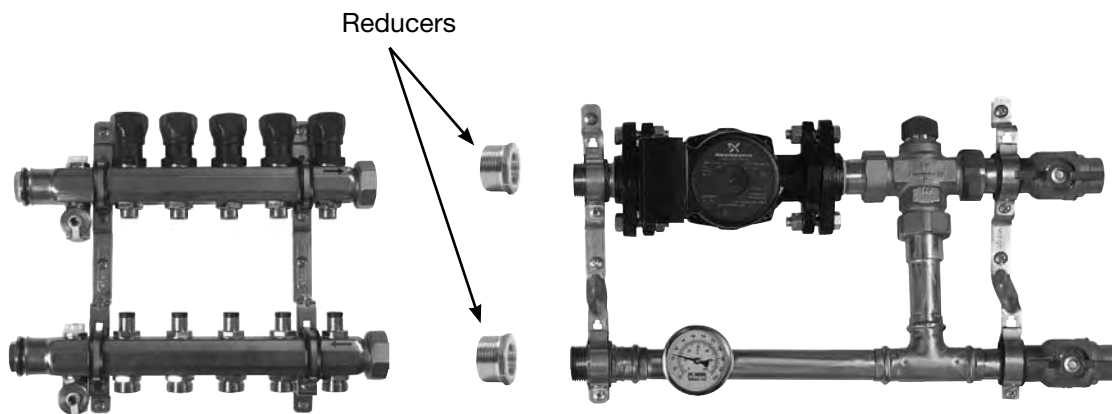

Note: It is important to use Teflon tape and thread sealant paste on all connections without gaskets.



4.2 SINGLE TEMPERATURE RADIANT SYSTEM

The Basic Heating Control is selected to modulate system water temperature as the outdoor temperature fluctuates. Multiple zones may be incorporated by adding Thermostats and a Zone Control.

Material	Quantity	Stock Code
Mixing Station	1	12120 - 12125
Basic Heating Control	1	16015
Indoor Sensor	1	16016
Three Position Actuator for Station	1	18003
1-1/4" Stainless Manifold, # Outlets*	1	15900-910

*Based on job requirements

Primary Loop Sizing*		
Copper Pipe Size (inches)	Flow Rate (GPM)	Heat Carrying Capacity (BTU/hr)
3/4	4	40,000
1	8	80,000
1-1/4	14	140,000
1-1/2	22	220,000
2	45	450,000

*Flow Rate and Heat Carrying Capacity calculation based on a 20°F temperature drop across the system.

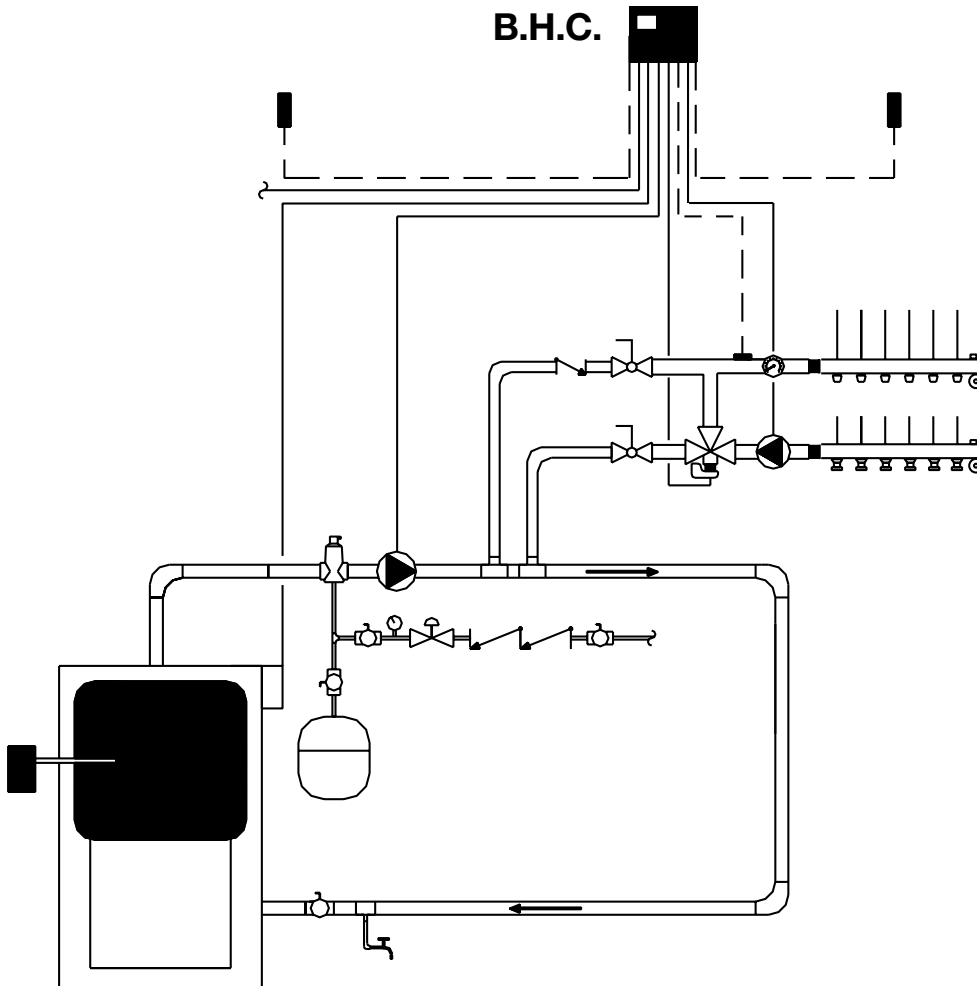

Note: All schematics are conceptual. The designer must determine whether this application will work in the system and must ensure compliance with national and local code requirements. Boiler trim (expansion tank, fill valve, relays, etc.) supplied by others.

4.2 SINGLE TEMPERATURE RADIANT SYSTEM WITH BOILER MODULATION AND OPTIONAL DHW CONTROL

The Advanced Heating Control incorporates low temperature mixing, provides boiler modulation, and the option of domestic hot water control with priority.

Optional DHW sensor may be in tank or on outlet piping. If boiler and DHW control are not needed, refer to Basic Heating Control diagrams.

Material	Quantity	Stock Code
Mixing Station	1	12120 - 12125
Advanced Heating Control	1	16014
Indoor Sensor	1	16016
Three Position Actuator for Station	1	18003
1-1/4" Stainless Manifold, # Outlets*	1	15700 - 15710
Thermostats	*	18002
Powerheads	3	15061
Optional DHW Sensor	1	16018
Transformer 24V	1	18008, 18020

*Based on job requirements

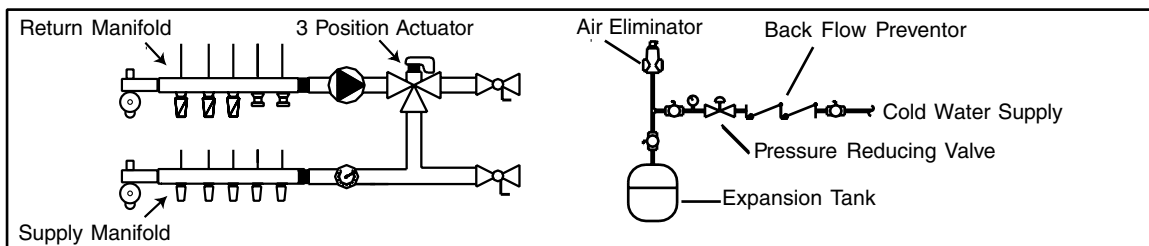
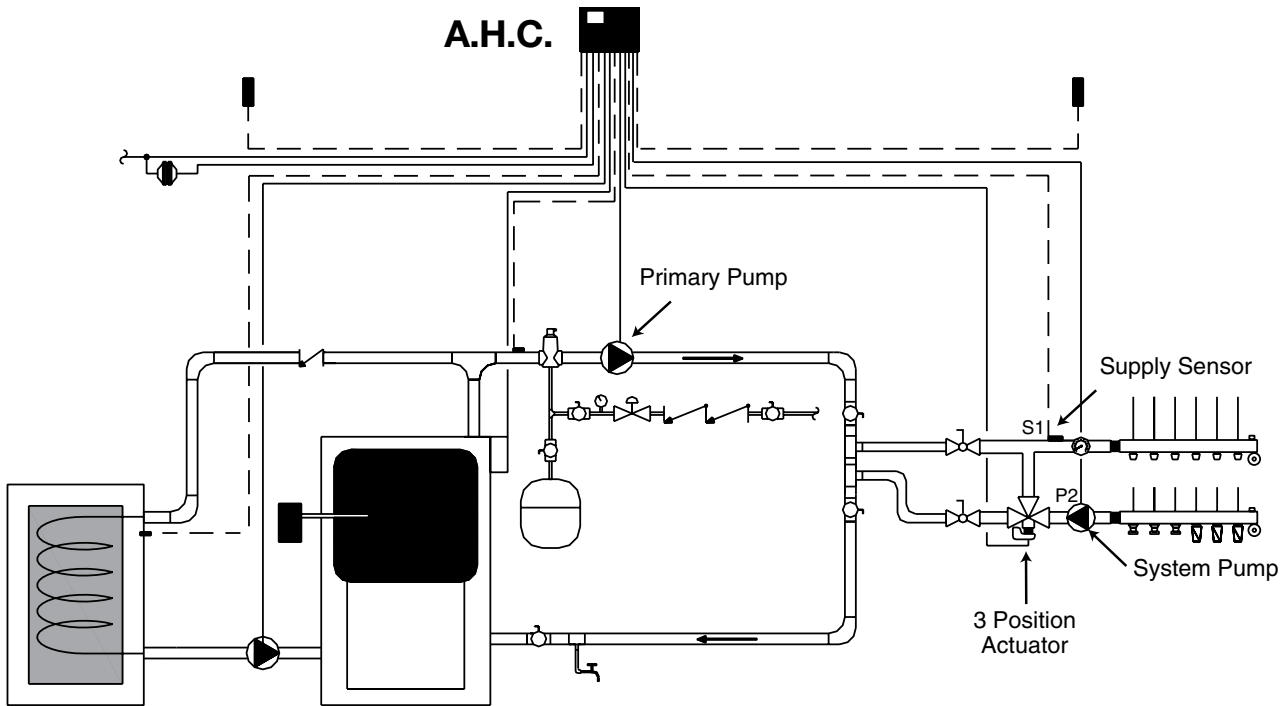



4.2 MULTIPLE TEMPERATURE RADIANT SYSTEM WITH BOILER MODULATION AND OPTIONAL DHW CONTROL

Note: If the heat loss and required water temperature varies throughout a building, a multiple water temperature system may be required. To add an additional temperature system, pipe in another Mixing Station with the necessary controls.

Material	Quantity	Stock Code
Mixing Station	2	12120 - 12125
Basic Heating Control	2	16015
Indoor Sensor	2	16016
Three Position Actuator for Station	2	18003
1-1/4" Stainless Manifold, # Outlets*	2	15012-022
Zone Control	2	18032
Thermostats	*	18029-031
Powerheads	*	15061
Optional DHW Sensor	1	16018
Transformer 24V	1	18008, 020

*Based on job requirements

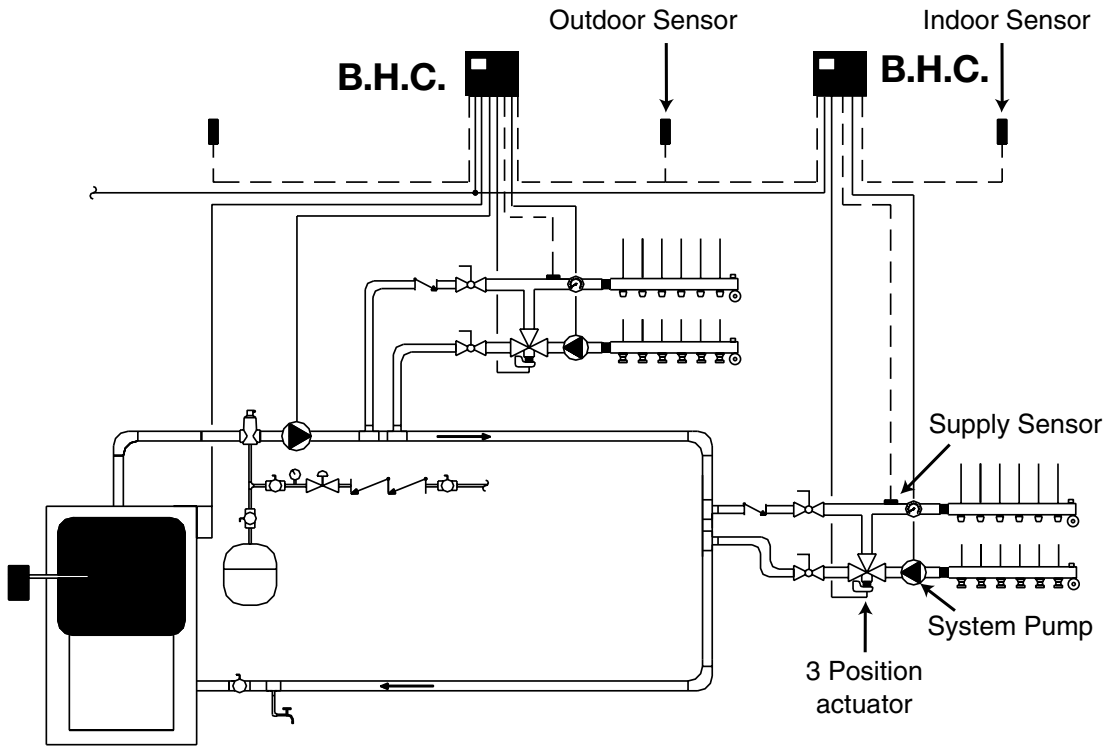

Primary Loop Sizing					
Copper Pipe Size [inch]	3/4	1	1-1/4	1-1/2	2
Flow Rate* [GPM]	4	8	14	22	45
Heat Carrying Capacity [BTU/h]	40,000	80,000	140,000	220,000	450,000

*Based on 6 FPS

4.3 Zone Wiring

A manifold system allows any one or more of the circuits to be adapted for control by a thermostat. The following are typical zone wiring schematics.

Detailed wiring diagrams are provided with products.

Important Note:

Installation by a licensed electrician is recommended. Installation and use of this equipment should be in accordance with provisions of the U.S. National Electric Code, applicable local code and pertinent industry standards.

Wiring Schematic: One Zone Application

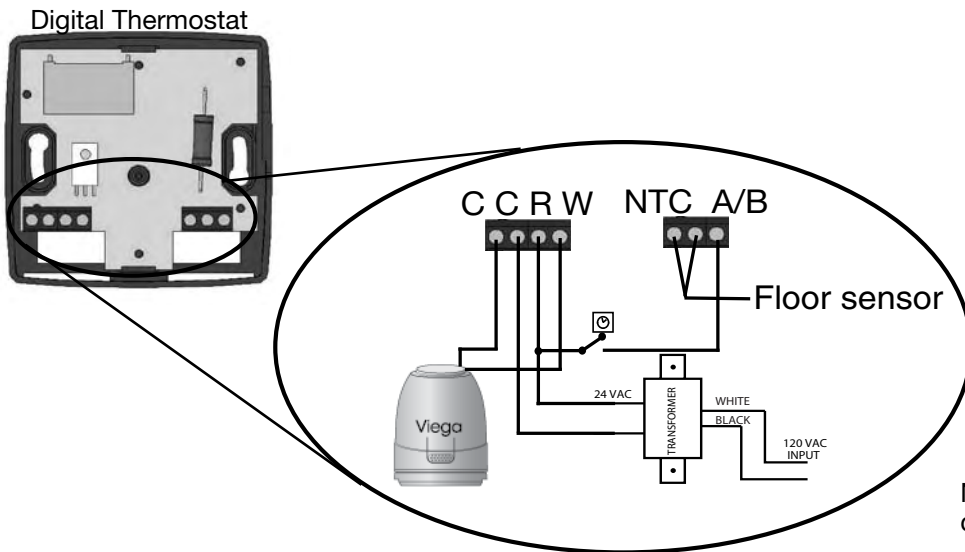

Note: Digital Thermostats can control up to 4 powerheads.

Wiring Schematic: Multi-Zone Application

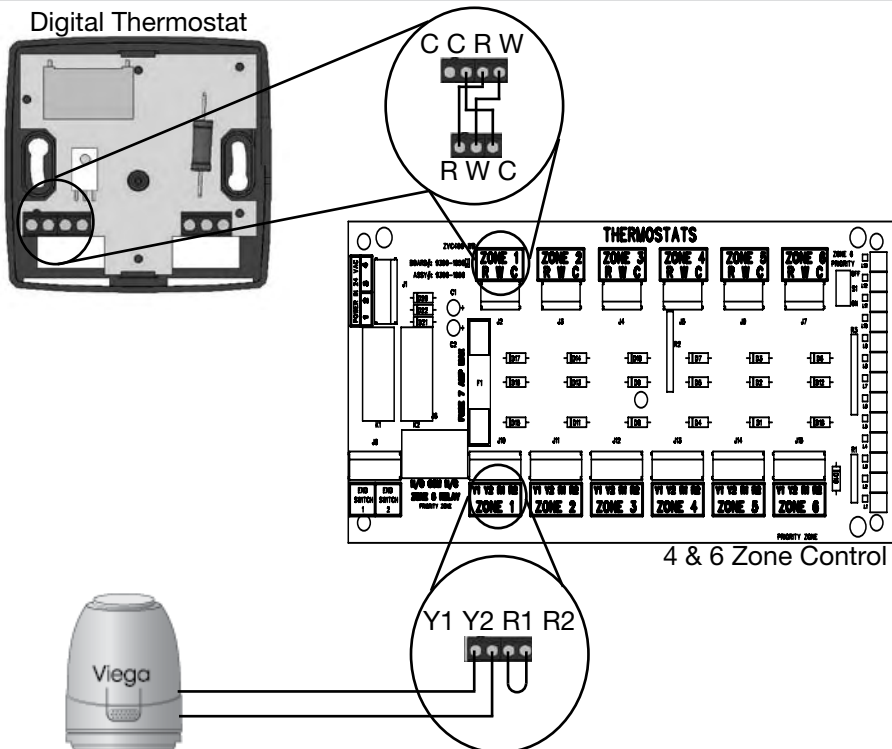

Note: 4 Zone Control (18060) can operate 8 powerheads. 6 Zone Control (18062) can operate 16 powerheads.

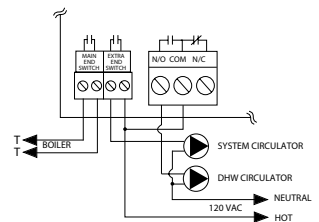

5. SYSTEM START-UP

5.1 Station and Actuator Installation

Material	
Product	Quantity
Mixing Station	1
Three Position Actuator	1
Manifold, # outlets*	1
Basic Heating Control	1
Indoor Sensor	1
FostaPEX	*
Press Adapters	4
Compression PEX Adapters	*

*Based on job requirements

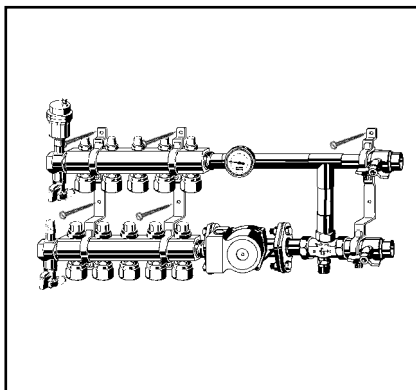

1. Mount the Mixing Station using the mounting brackets.

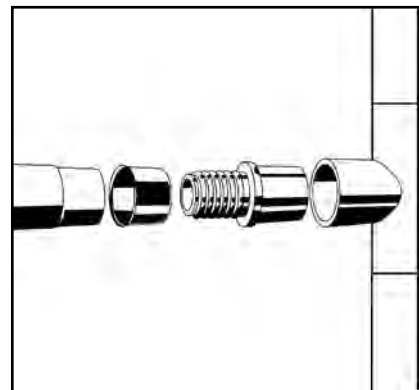

2. Make the press connection for the supply and return lines to the Mixing Station on the copper tee. Install tees as close as possible to keep pressure difference at a minimum.

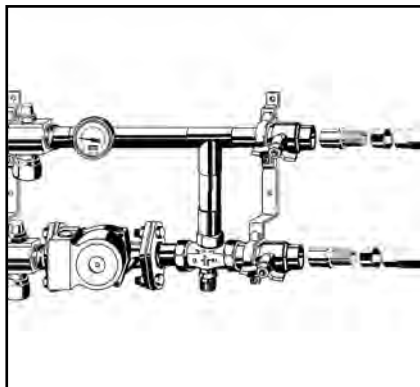

3. Connect the supply and return lines by soldering on a ViegaPEX Press adapter, then pressing on ViegaPEX Barrier or FostaPEX.

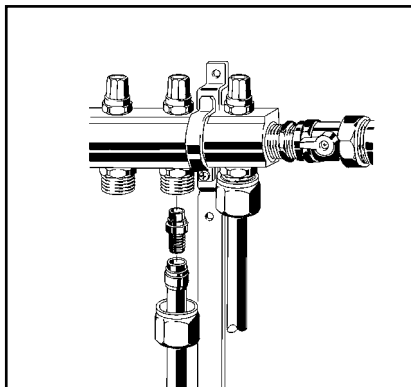

4. Use the SVC Compression or PEX Press Adapters to connect the ViegaPEX Barrier lines to the manifold.

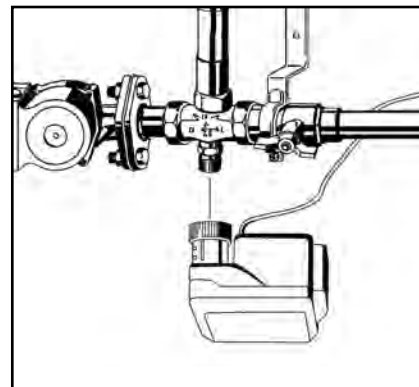

5. Remove the grey cap from the diverting valve on the Mixing Station and screw the actuator on hand tight.†

† Perform step 5 after the system has been filled and purged; refer to section 5.2 for procedure.

5.2 Purging and Pressure Testing the System

Operation

Purging

1. Attach drain hose to purge valve hose connection on return header and open valve.
2. Close all but one balancing valve on supply header (under red caps, turn with 5mm allen key). Close isolation ball valve on boiler return line. Remove plastic dust cap or temperature controller from diverting valve, and make sure that high limit kit is fully open.
3. Open boiler fast fill valve to purge circuit. After purging first circuit, close red balancing valve and open next one. Continue with one circuit at a time until all circuits have been purged.
4. Close purge valve and open all balancing and boiler valves. Reset high-limit kit, and reinstall actuator onto diverting valve.
5. Any remaining air pockets in the system will be eliminated through the automatic air vent after a few hours of constant circulation.

NOTE: If the system must be purged again in the future for any reason, the high-limit kit must be reopened during purging for full flow.

Pressure Testing

Before the finish floor is installed, the radiant system must be pressure tested. Air or water may be used as the medium.

The following procedure is recommended by Viega. Check the local building codes for compliance or additional test requirements.

Procedure:

1. Double-check all connections to manifold to ensure proper seal.
2. Connect manifold pressurization kit (1) to any purge valve (2).
3. Pressurize the system to 80 psi to detect potential nail or screw penetrations.
4. The system should hold the 80 psi for a minimum of 24 hours.

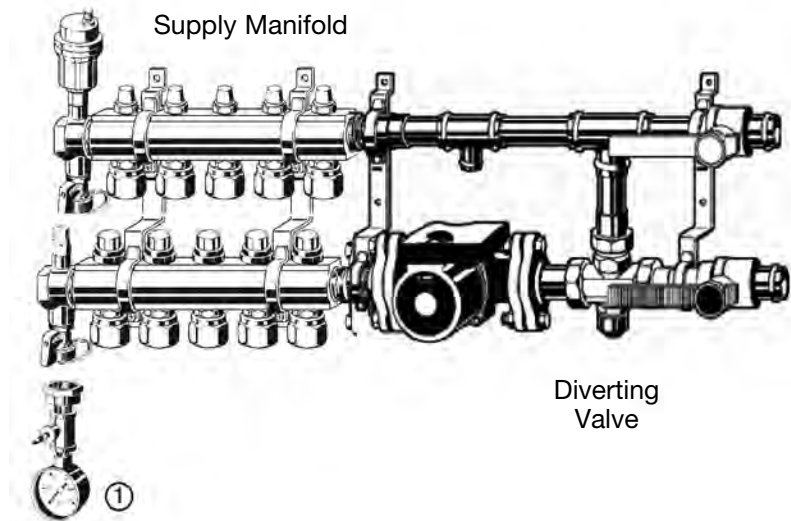

Note: If the tubing is damaged, repair punctured section with a compression coupling.

Contractor: Maintain pressure during the installation of the finish floor to simplify leak detection if tubing is damaged.

5.3 Adjusting the High Limit Kit

Operation

The Mixing Station is provided with a preinstalled temperature High Limit Kit. This kit is installed into the

three-way valve to allow a maximum supply water temperature to be set. This kit must be unscrewed when purging the system, and should then be set according to the instructions below.

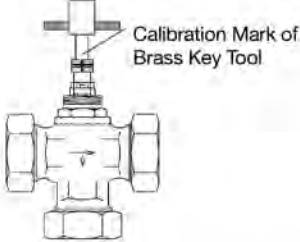
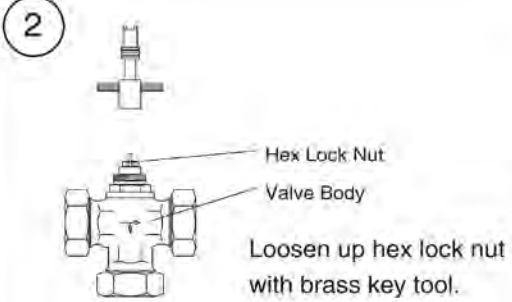
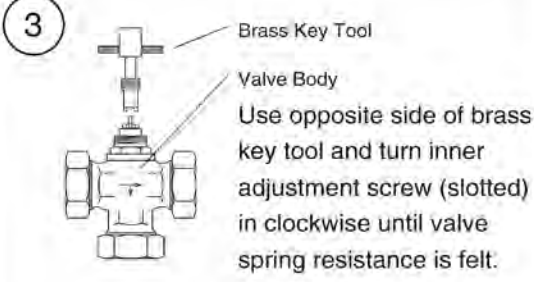
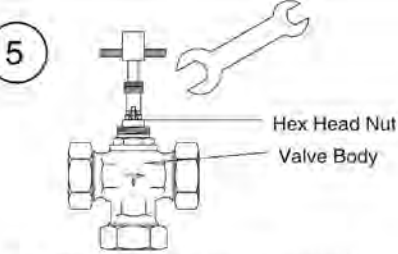
<p>1</p>  <p>Remove grey plastic cap from valve body.</p>	<p>4</p> <p>Note: This calibration must be done with the boiler at its highest temperature, the circulator running and all zones open.</p> 
<p>2</p>  <p>Loosen up hex lock nut with brass key tool.</p>	<p>Turn adjustment screw further clockwise until desired supply water temperature is obtained; count quarter turns for reference. This has to be done carefully and slowly because each quarter turn of the adjustment screw will result in approximately 15°F temperature reduction. Wait until desired water temperature stays consistent.</p>
<p>3</p>  <p>Use opposite side of brass key tool and turn inner adjustment screw (slotted) in clockwise until valve spring resistance is felt.</p> <p>To lower water temperature, turn key clockwise; turn counterclockwise to raise it.</p>	<p>5</p>  <p>Tighten hex lock nut with wrench. Do not overtighten! To secure high limit adjustment, hold slotted adjustment screw with brass key, while tightening lock nut.</p>

5.4 Initial Balancing

Many times it is not possible to design the system using equal circuit lengths, so the system must be balanced in order to ensure adequate flow to each circuit on a manifold.

(Refer to your Radiant Wizard design program for detailed balancing).

Procedure:

1. Start with all valves wide open.
2. To decrease flow, turn the balancing valve clockwise in small increments.

Note: Remove red caps and turn balancing valves with included allen key. Valves are hidden to prevent tampering.

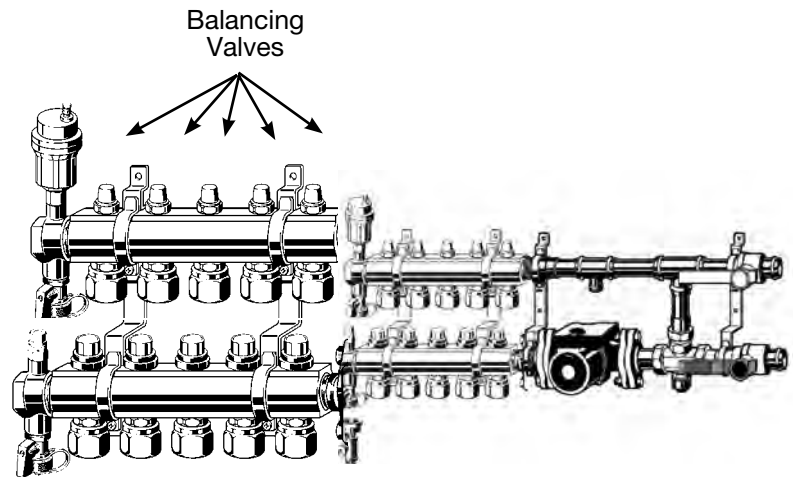

6. FINISH FLOORING

6.1 Choosing a Finished Floor

There are three common types of finished floors used in residential construction: wood floors, tile/vinyl, and carpet.

When picking a finished floor, the lower the R-value, the better radiant heat will work. When using tile, the R-value will be low and therefore will work very well with your radiant system (Appendix D on page 33 lists some common tiles and their R-values).

Vinyl flooring is another common choice for kitchens and baths and has a low R-value.

Using carpet over radiant heating requires careful planning. Viega's recommendation for a covering over a radiant system is to not exceed a total of a 2.5 R-value (the carpet pad plus the carpet itself).

Remember that the pad and the carpet are insulators and will restrict the heat from getting into the room, so keeping the R-value of the pad and the carpet low is a must in below subfloor application (Appendix D on page 33 lists some carpet and pad R-values). It may be necessary to add supplemental heat or install hydronic baseboards in rooms with heavy carpeting (see Viega's Combiflex system).

There are many questions regarding hardwood flooring over radiant heating. Armed with knowledge and a few precautions, hardwood floors and radiant heat will work well together. There are two important issues:

1. Floor surface temperatures
2. Moisture

Floor Surface Temperatures

For many builders, a reluctance to install hardwood floors over radiant heat stems from problems associated with incorrect control of the floor surface temperatures.

- Today, modern insulation and building techniques allow a radiant floor to stay cooler than the floor of the average sunroom.
- The floor surface temperature should not exceed 85°F (refer to section 2.4 to calculate the floor surface temperature).

Also be careful when using multiple or high R-value area rugs over hardwood flooring. Your radiant heating system must be designed with this additional R-value taken into account in order to perform properly. If the system was designed for bare wood flooring, adding area rugs may lead to a situation where heat output is diminished.

Moisture

Allow the radiant system to run for at least a week before installing the hardwood. This will ensure that the subfloor is dry. Wood flooring should be acclimated to the job site before installation. When checking the moisture content of the subfloor and wood flooring with a moisture meter, aim for a reading of 6% to 8%. Moisture will affect the hardwood floor with or without a radiant system.

- Moisture absorption causes wood to swell.
- Moisture loss causes wood to shrink.

If the moisture content of the wood is relatively high near the bottom

of the plank, cupping upward will occur exaggerating cracks.

Dry Shrinkage

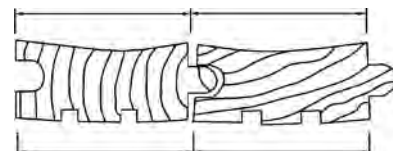

If the moisture content is relatively high near the top surface of the plank, it will crown downward on the edges.

Wet Expansion

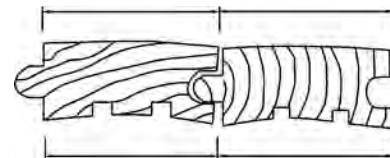

Sources from below:

- Inadequate moisture barrier
- Ground water wicking through the slab
- Unsealed subfloor

Sources from above:

- High relative humidity

Both solid plank flooring and engineered wood floors are acceptable choices over radiant heating.

Choosing narrower planks and harder woods minimizes dimensional change in the wood. Engineered wood flooring usually has less expansion and contraction and can be a good choice to minimize gaps between planks.

Note: Follow the flooring manufacturer's installation manual or NOFMA's (National Oak Flooring Manufacturers Association) manual.

MAKING A PRESS CONNECTION - APPENDIX A

When piping a Mixing Station to a primary loop, FostaPEX is suggested. This method will produce a higher quality outcome, while reducing installation time.

Follow these steps each time you make a FostaPEX connection.

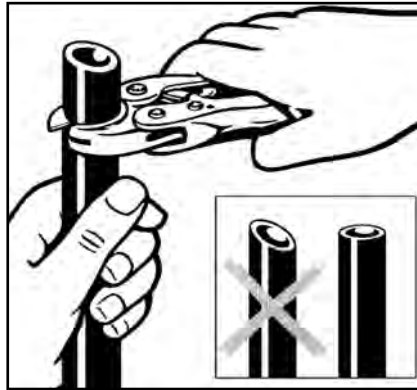

1. Square off tubing to proper length.

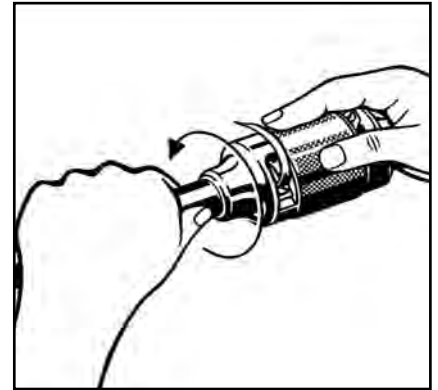

2. Insert FostaPEX tubing into prep tool. Push and turn tool until no more resistance is felt and tool spins freely. (This step applies to FostaPEX only)



3. Slide press sleeve fully over end of tubing.

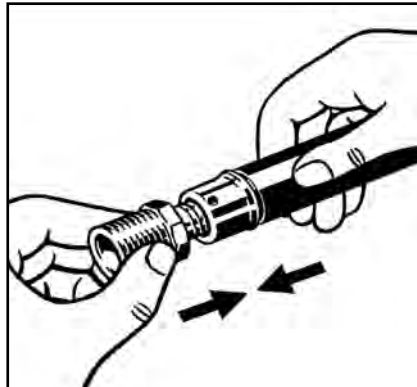

4. Insert compression fitting into tubing and engage fully.

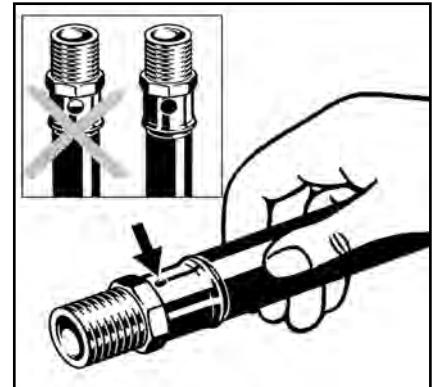

5. Check full tubing insertion at view hole of sleeve.

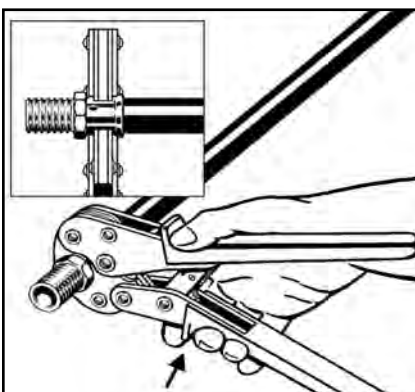

6. Engage press tool perpendicular over press sleeve and close tool jaws.

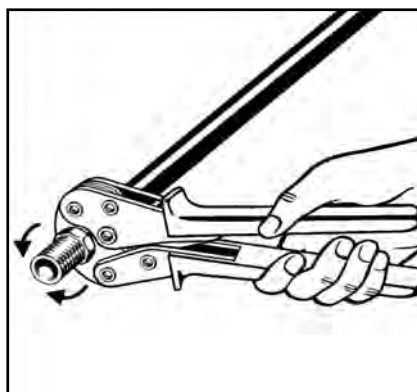

7. Start tool ratchet until automatic tool release occurs at proper compression force.

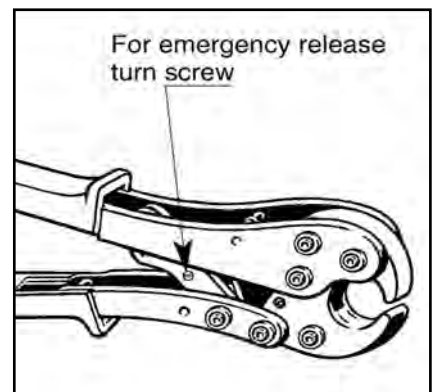

8. Warning: The connection is not leakproof when the tool has been opened by emergency release.

SVC COMPRESSION COUPLING 3/8" - 5/8" - APPENDIX B

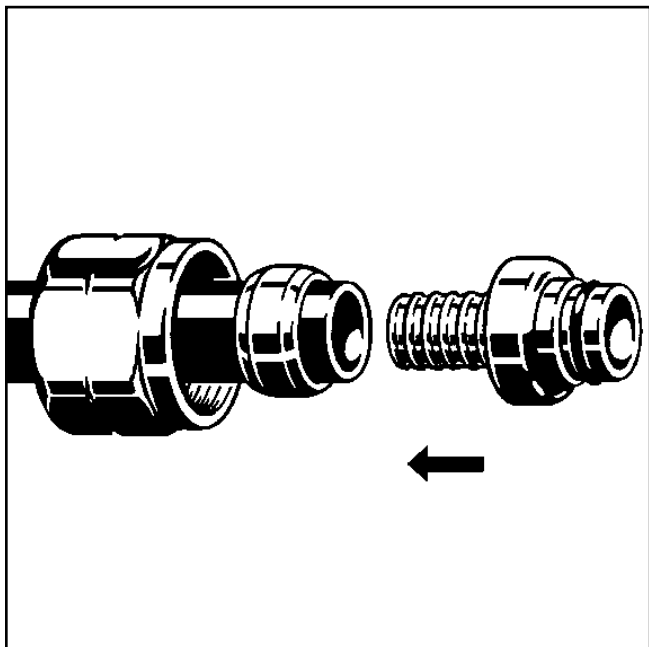

1. Square off tubing to proper length. Slide compression nut up tubing and slip brass ferrule over tubing.

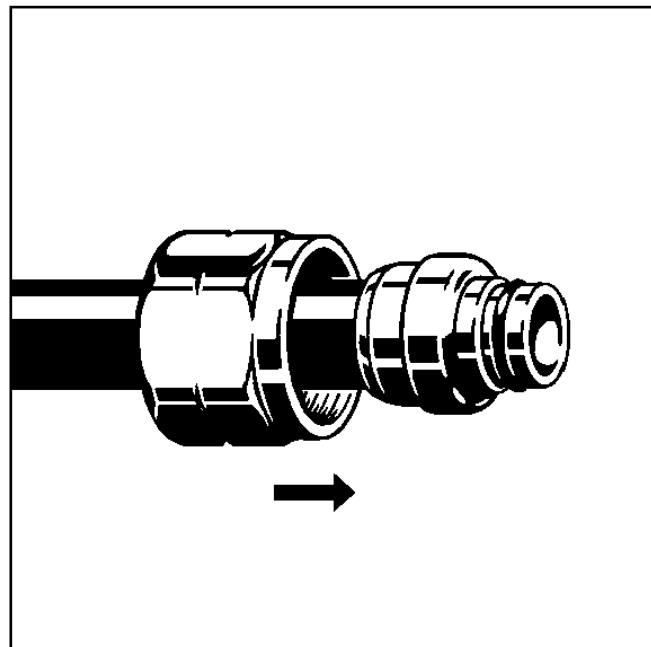

2. Slide tubing over end of SVC adapter, pushing it on fully until tubing is flush with shoulder of fitting.

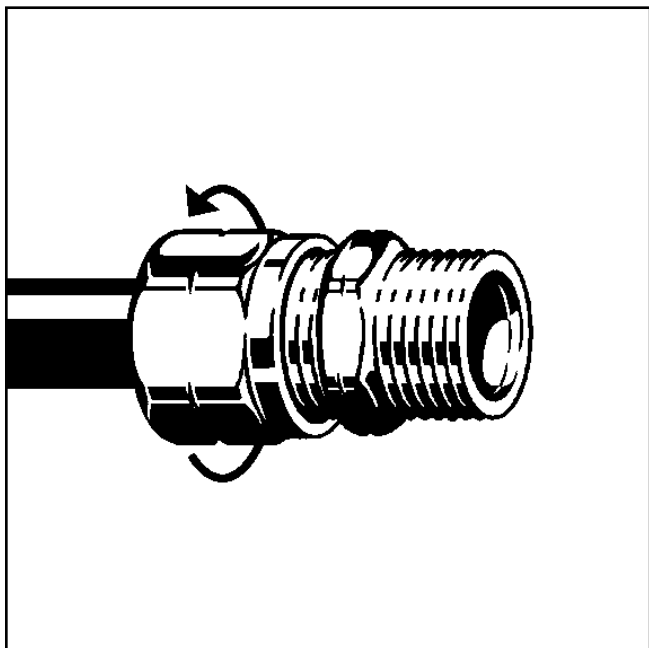

3. Insert adapter into SVC coupling and tighten compression nut to SVC coupling to secure adapter. Re-tighten compression nut slightly after 30 mins.

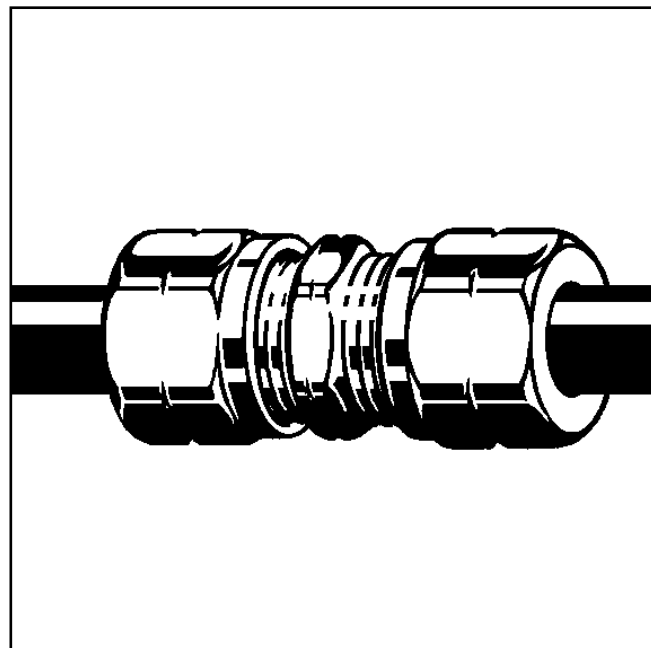

4. Repeat the same procedure for the other side of the SVC compression coupling.

RECOMMENDED TOOLS FOR INSTALLATION - APPENDIX C

• Installation (Power Tools) •

1. Staple Gun with swivel connected hose (staples - 7/16" - 1/2" crown by 3/4" - 1")
2. Compressor (1.5-2 hp)
3. Radial Arm Chop Saw - for cutting Traks
4. Right Angle Drill with bit kit (1-1/4") - for drilling joists
5. Palm Hammer (medium plastic hammer tip)
6. Screw Gun (3/4" - 1" tech screws)
7. Nail Grinder (4-1/2")

• Installation (Hand Tools) •

1. Tape Measure (recommended 1 per person)
2. Heavy-Duty Nail Cutter - cleaning joists
3. Rubber Mallet - snapping tubing into Climate Traks
4. Decoiler
5. Hammer - bending nails, miscellaneous
6. Chalk Line - chalking joists for hole or plate placement
7. Wrench - manifold connections
8. Tubing Cutter
9. Utility Knives (deburring and opening boxes)
10. Caulking Gun (only with heat transfer plates)

• Miscellaneous •

1. Safety Glasses (highly recommended!)
2. Earplugs
3. Rolling Scaffolding or Sheet-rocker Stilts or Ladders
4. Lights (especially in basement applications)
5. Broom



R-VALUE TABLE FLOOR COVERINGS - APPENDIX D

	1/8"	1/4"	3/8"	1/2"	5/8"	3/4"	7/8"	1"
Building Board								
Gypsum or Plaster Board	0.11	0.23	0.32	0.45	0.56	0.68	0.79	0.90
Plywood	0.16	0.31	0.47	0.62	0.77	0.93	1.09	1.24
Particleboard, low density	0.18	0.35	0.53	0.71	0.88	1.06	1.23	1.41
Particleboard, medium density	0.13	0.27	0.40	0.53	0.66	0.80	0.93	1.06
Particleboard, high density	0.11	0.21	0.32	0.43	0.53	0.64	0.74	0.85
Waferboard	0.20	0.40	0.60	0.80	0.99	1.19	1.39	1.59
Wood Subfloor	0.16	0.31	0.47	0.62	0.78	0.93	1.09	1.24
Cement board	0.03	0.06	0.09	0.12	0.15	0.18	0.21	0.24
Tile								
Ceramic Tile	0.02	0.03	0.05	0.07	0.08	0.10	0.12	0.13
Marble	0.01	0.01	0.02	0.03	0.03	0.04	0.04	0.05
Granite	0.01	0.02	0.03	0.04	0.05	0.06	0.07	0.08
Slate	0.01	0.03	0.04	0.05	0.06	0.08	0.09	0.10
Linoleum or Vinyl	0.05	0.10	0.15	0.20	0.25	0.30	0.35	0.40
Rubber, hard	0.12	0.24	0.36	0.48	0.60	0.72	0.84	0.96
Cork Tile	0.28	0.56	0.84	1.12	1.40	1.68	1.96	2.24
Carpet Pad								
Waffled Sponge Rubber	0.20	0.41	0.61	0.81	1.01	1.22	1.42	1.62
Synthetic Jute	0.43	0.86	1.28	1.71	2.14	2.57	2.99	3.42
Bonded Urethane, 4 lb Density	0.52	1.05	1.57	2.09	2.61	3.14	3.66	4.18
Bonded Urethane, 8 lb Density	0.55	1.10	1.65	2.20	2.75	3.30	3.85	4.40
Prime Urethane, 2.2 lb Density	0.54	1.08	1.61	2.15	2.69	3.23	3.76	4.30
Carpet								
Acrylic Level Loop	0.52	1.04	1.56	2.08	2.60	3.12	3.64	4.16
Acrylic Level Loop w/ Foam Back	0.51	1.02	1.53	2.04	2.55	3.06	3.57	4.08
Acrylic Plush	0.43	0.86	1.29	1.72	2.15	2.58	3.01	3.44
Polyester Plush	0.48	0.96	1.44	1.92	2.40	2.88	3.36	3.84
Nylon Level Loop	0.68	1.36	2.04	2.72	3.40	4.08	4.76	5.44
Nylon Plush	0.26	0.52	0.78	1.04	1.30	1.56	1.82	2.08
Nylon Shag	0.27	0.54	0.81	1.08	1.35	1.62	1.89	2.16
Nylon Saxony	0.44	0.88	1.32	1.76	2.20	2.64	3.08	3.52
Wool Plush	0.55	1.10	1.65	2.20	2.75	3.30	3.85	4.40
Hardwood								
Ash	0.15	0.30	0.45	0.60	0.75	0.90	1.05	1.20
Beech	0.12	0.24	0.36	0.48	0.60	0.72	0.84	0.96
Cherry	0.15	0.30	0.45	0.60	0.75	0.90	1.05	1.20
Elm	0.14	0.28	0.42	0.56	0.70	0.84	0.98	1.12
Maple	0.13	0.26	0.39	0.52	0.65	0.78	0.91	1.04
Oak	0.15	0.30	0.45	0.60	0.75	0.90	1.05	1.20
Cedar	0.23	0.46	0.69	0.92	1.15	1.38	1.61	1.84
Fir	0.15	0.30	0.45	0.60	0.75	0.90	1.05	1.20
Hemlock	0.18	0.36	0.54	0.72	0.90	1.08	1.26	1.44
Pine	0.20	0.40	0.60	0.80	1.00	1.20	1.40	1.60
Redwood	0.20	0.40	0.60	0.80	1.00	1.20	1.40	1.60
Spruce	0.20	0.40	0.60	0.80	1.00	1.20	1.40	1.60
Engineered Flooring								
Laminated Parquet Flooring	0.11	0.23	0.34	0.45	0.57	0.68	0.79	0.91

SUPPLY WATER TEMPERATURE/BTU OUTPUT CHARTS - APPENDIX E

Climate Trak 6" Spacing BTU Output

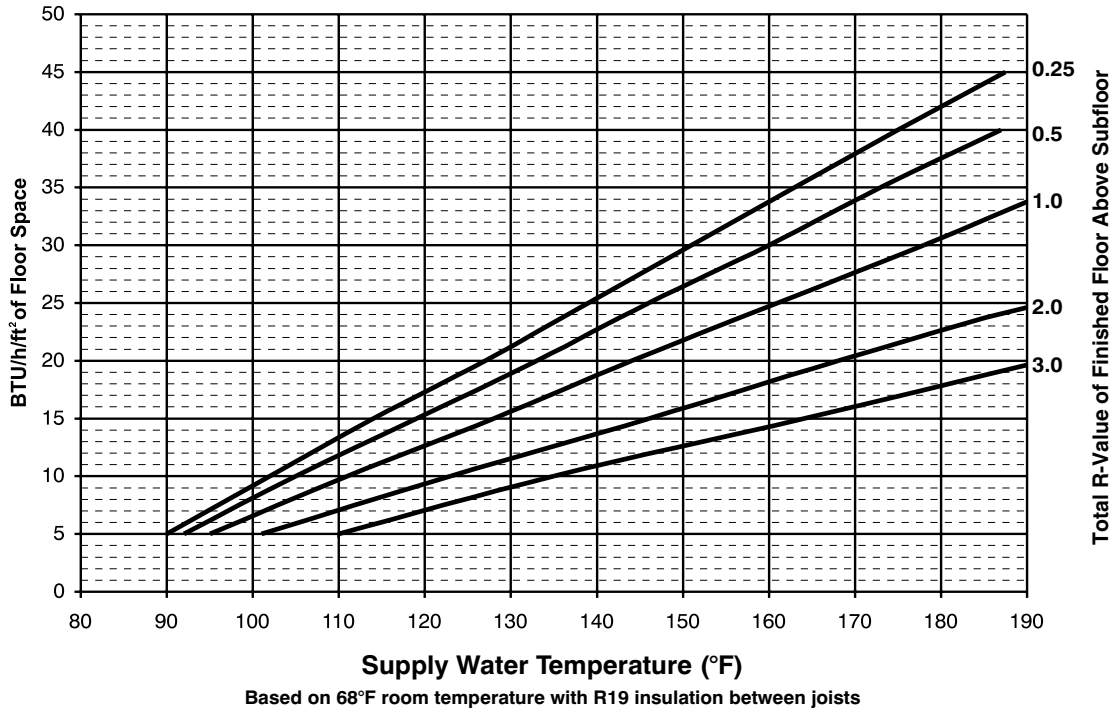

Climate Trak 8" Spacing BTU Output

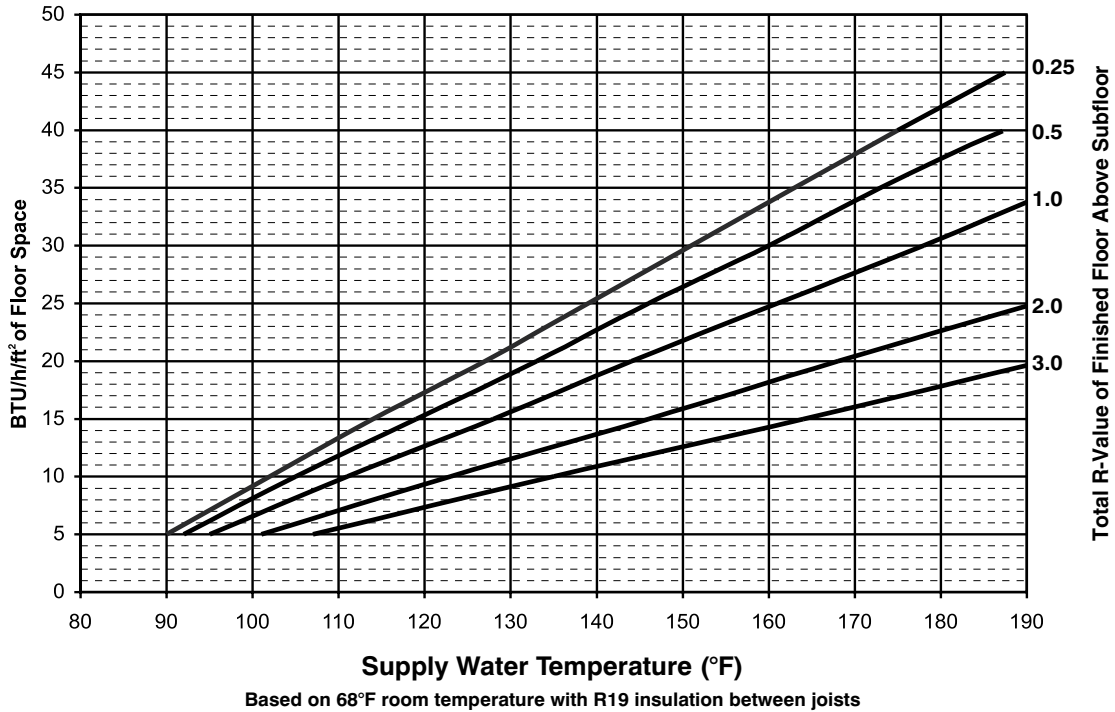

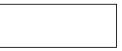

SUPPLY WATER TEMPERATURE/BTU OUTPUT CHARTS - APPENDIX E

Climate Trak 9" Spacing BTU Output

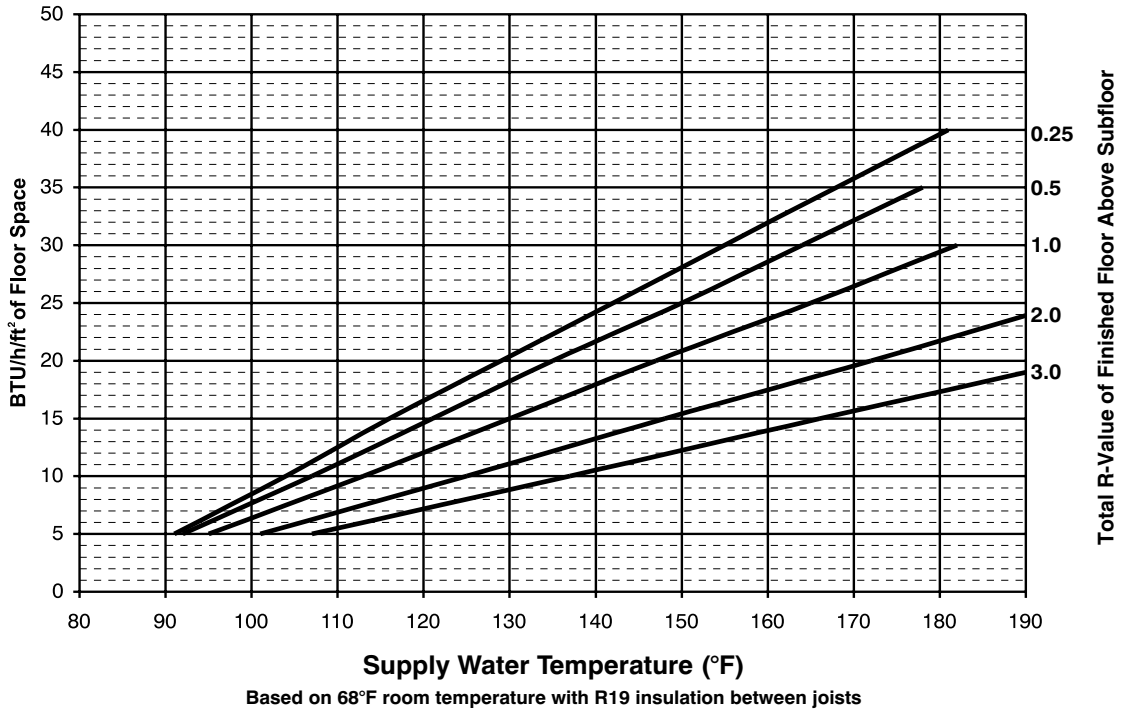

Climate Trak 12" Spacing BTU Output

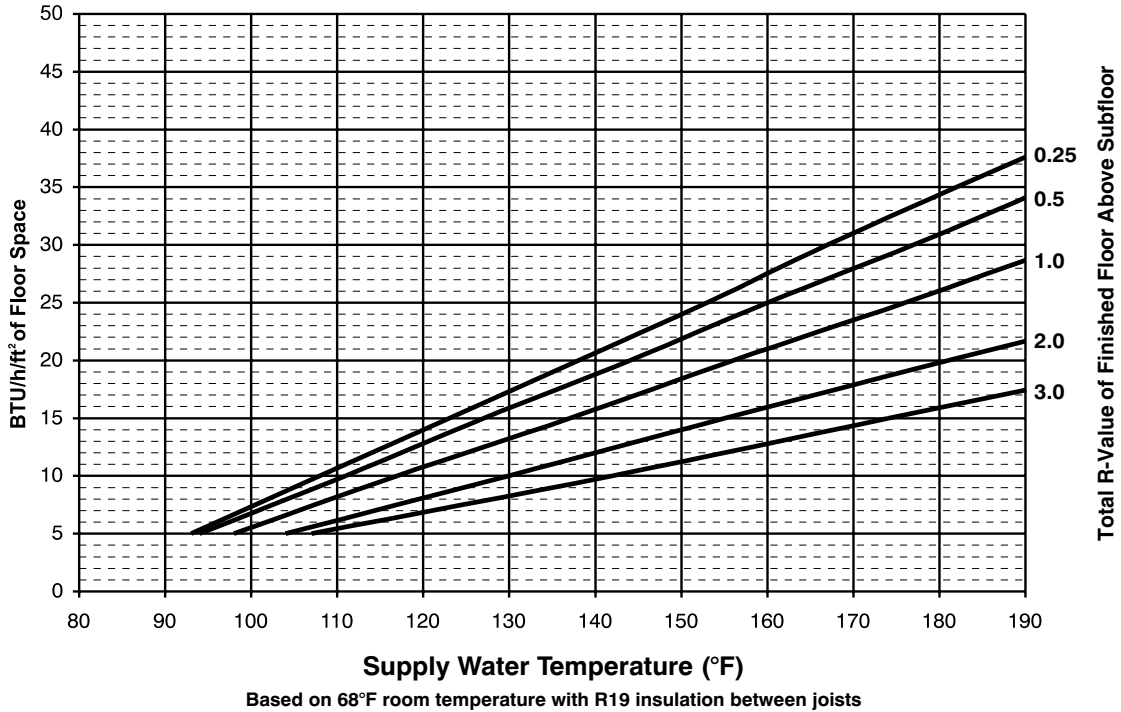

SUPPLY WATER TEMPERATURE/BTU OUTPUT CHARTS - APPENDIX E

Climate Trak 16" Spacing BTU Output

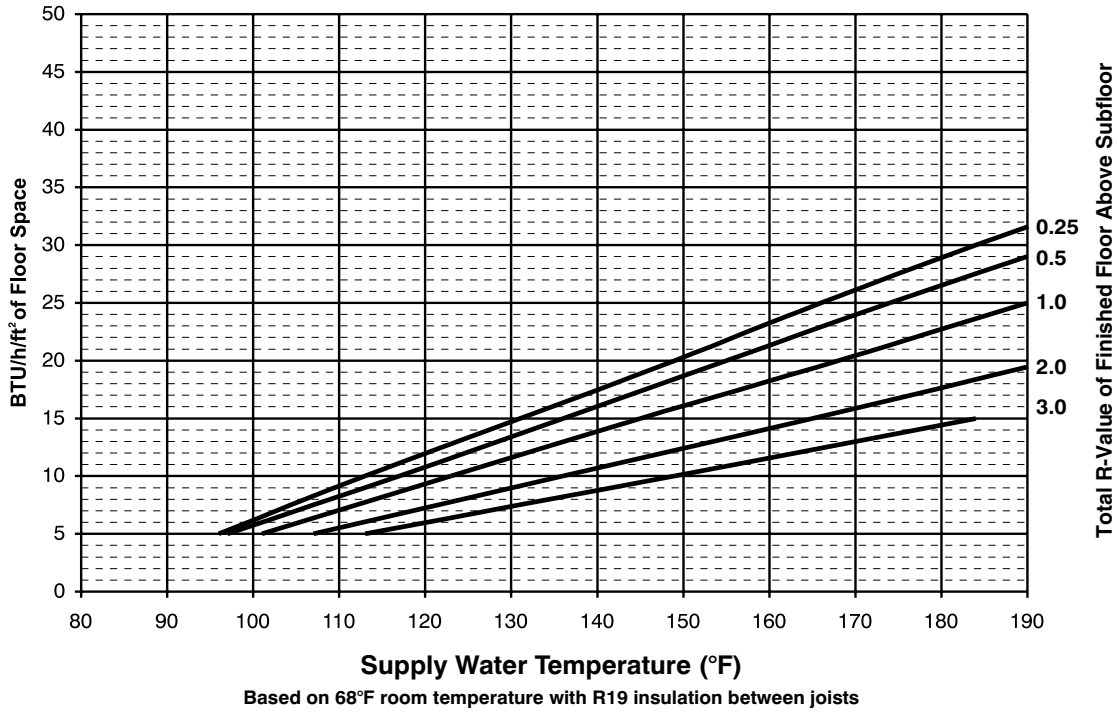

Climate Trak 18" Spacing BTU Output

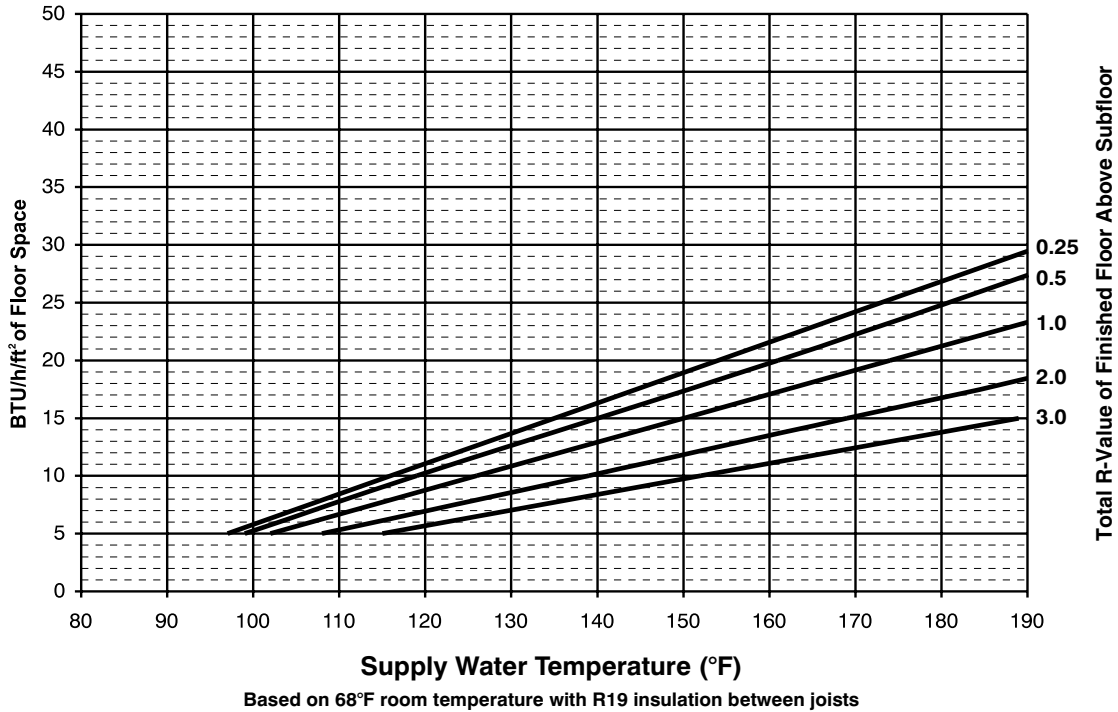



MAKING A MATERIAL LIST - APPENDIX F

CLIMATE TRAK MATERIAL WORKSHEET

8 ft. Climate Traks	Net Heated Area	Multiplier	Estimated Amount
6" Spacing		.23	
8" Spacing		.18	
9" Spacing		.16	
12" Spacing		.12	
16" Spacing		.09	
18" Spacing		.08	

4 ft. Climate Traks	Net Heated Area	Multiplier	Estimated Amount
6" Spacing		.47	
8" Spacing		.35	
9" Spacing		.31	
12" Spacing		.23	
16" Spacing		.18	
18" Spacing		.16	

Tubing 3/8" or 1/2"	Net Heated Area	Multiplier	Estimated Amount
6" Spacing		2.2	
8" Spacing		1.7	
9" Spacing		1.5	
12" Spacing		1.1	
16" Spacing		.85	
18" Spacing		.75	

Material List	
Products	Quantity
Mixing Station	
Advanced Heating Control	
Basic Heating Control	
Actuator	
1-1/4" Stainless Manifold, # outlets	
1" Brass Manifolds, # outlets	
Manifold Accessory Set (Used With Brass Only)	
Zone Control	
Thermostats	
Powerheads for Stainless	
Powerheads for Brass	
Manifold PEX Press Adapters	
Manifold Compression PEX Adapters	

These charts are intended for conceptual purposes only; there may be variations in each job.

NOTES

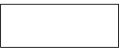

NOTES

Professional products, service, and training for professional contractors



Rely on Viega for the most complete line of high tech/
high quality plumbing, heating and snow melting
systems available today ... plus the most comprehensive
customer field support in the industry.

Dedicated to education, Viega has been recognized
by industry professionals as offering some of the most
innovative, informative and interactive training courses.
We have a comprehensive list of sessions in a variety
of forms from half-day workshops to rigorous three-day
programs. Call to receive our complete course catalog.



Viega

301 N. Main, 9th Floor, Wichita, KS 67202
Phone: 1-800-976-9819 Fax: 1-800-976-9817
www.viega.com service@viega.com

Viega IM-PR-Climate Trak 0209

ProPress® System

Flameless
copper joining
technology.



ProPressG™ System

Flameless
copper fuel
gas joining
technology.



Pure Flow® Systems

Flexible
PEX tubing
plumbing
technology.



ProRadiant Systems

Comfortable,
efficient heating
technology.



S-no-Ice® System

Snow and
ice melting
technology.

