

Split System Submittal Data



Building Life.

System: 12KHS71 Indoor/Outdoor: KHS1271/CH1271
Wall Mounted Heat Pump

Job Name: _____
 Location: _____
 Engineer: _____
 Submitted to: _____
 Submitted by: _____
 Reference: _____

Approval: _____
 Date: _____
 Construction: _____
 Unit #: _____
 Drawing #: _____



General Data (at 115V)

Power	V/PH/Hz	115/1/60
Circuit Ampacity	(A)	20
Fuse Size, Max.	(A)	20

Compressor	DC Rotary Inverter	
No. used		1
R.L. Amps - L.R.	(A)	9.8/10.6-20
Crankcase Heater	(W)	20

Outdoor Unit		
Fan type		Propeller
Dia. (in.) - No. Speeds		15-3/4-1
Type Drive - No. Speeds		Direct - 3
No. Poles	(RPM)	8-750
No. Motors	(W)	30-1
CFM	(High)	1059
F.L. Amps	(A)	0.6

Coil Type	Aluminum Fin & Copper Pipe	
Fin Type - Pipe Type	Corrugated Plate - Inner Rifled	
Rows - F.P.I.		2-18.1
Face Area	(sq.ft.)	3.95
Tube Size	(in.)	5/16"

Indoor Unit		
Fan type		Cross Flow
Dia. & Length (in.) - No. Speeds	D3-11/6	L24-31/32-1
No. Speeds		3 & Auto
No. Poles	(RPM, High)	4-1250
No. Motors	(W)	14.8-1
CFM	(Hi/Med/Lo)	294/259/212
Indoor Sound Rating	(Hi) (dB-A)	36
F.L. Amps	(A)	0.346

Coil Type	Aluminum Plate Fin & Copper Tube	
Fin Type - Pipe Type	Slit Plate - Inner Rifled	
Rows - F.P.I.		2-19.5
Face Area	(sq.ft.)	2.02
Tube Size	(in.)	9/32"
Drain Connection Size	(in.)	23/32"

Refrigerant	R410A
Lbs. - R410a (outdoor unit)	2.43
Control	Electric Expansion Valve
Connection	Flare
Line Length, Max (ft.)	65
Lift Difference, Max (ft.)	23
Line Size	(in. O.D. Discharge) 1/4"
Line Size	(in. O.D. Suction) 3/8"

Dimensions	(in.)	H x W x D
Indoor Unit	(Uncrated) 11-7/32 x 32-15/32 x 7-7/16	
	(Crated) 13-25/32 x 35-7/16 x 10-1/32	
Outdoor Unit	(Uncrated) 21-9/16 x 28-11/32 x 10-7/16	
	(Crated) 23-5/8 x 33-11/16 x 14-1/4	

Weight		Indoor	Outdoor
Net	(lbs.)	19.8	77.2
Shipping	(lbs.)	24.3	83.8
Shipping Volume	(cu.ft.)	2.82	6.36

Performance Data @ ARI Standard Conditions (115V)

Cooling		
Total Capacity	(BTU/H)	11,900 (3,000-11,900)
Sensible Capacity	(BTU/H)	9,100
Latent Capacity	(BTU/H)	2,800
SEER		17
Dehumidification	(Pints/H)	4.26
Amps	(A)	-/10.9 (2.5-10.9)
Power Inputs	(W)	-/1,090 (250-1,090)
Outdoor Sound Rating	(dB-A)	47

Heating		
Total Capacity	(BTU/H)	14,300 (3,000-14,300)
HSPF		9.3

Dimensions

Heating

Amps	(A)	-/11.7 (2.5-11.7)
Max. Amps	(A)	20
Power Inputs	(W)	-/1,165 (250-1,165)
Back-up Strip Heater	(KW)	N/A
Outdoor Sounds Rating	(dB-A)	49

Features

Controls	Microprocessor
Remote Controller	LCD Wireless Type, Temp. Sensor Built In
Temperature Control	IC Thermostat
Timer	24 Hr. Program; 1HR Off
Night Setback	Built-In
Air Louver	(Horizontal) Manual (Vertical) Automatic
Power Failure Automatic Restart	Built-In
Heating/Cooling Automatic Changeover	Built-In
Self-Diagnosis	Built-In
Quiet Operation	Built-In
Ion Generator	Built-In
Air Clean Apatite Filter	Standard
Air Filter	Washable, Anti-Mold

Options

Refrigerant Line Set	Available
Fresh Air Intake	N/A
Air duct Extension	N/A
Condensate Drain Pump	Available
Hard Wired Remote Controller	Available
Non-Removeable Remo-con Bracket	Available

Operating Range

		Indoor Air Intake Temp.	Outdoor Air Intake Temp.
Cooling	Maximum	95F DB/71F WB	115F DB
	Minimum	67F DB/57F WB	0F DB
Heating	Maximum	80F DB/67F WB	75F DB/65F WB
	Minimum	-DB/-WB	0F DB

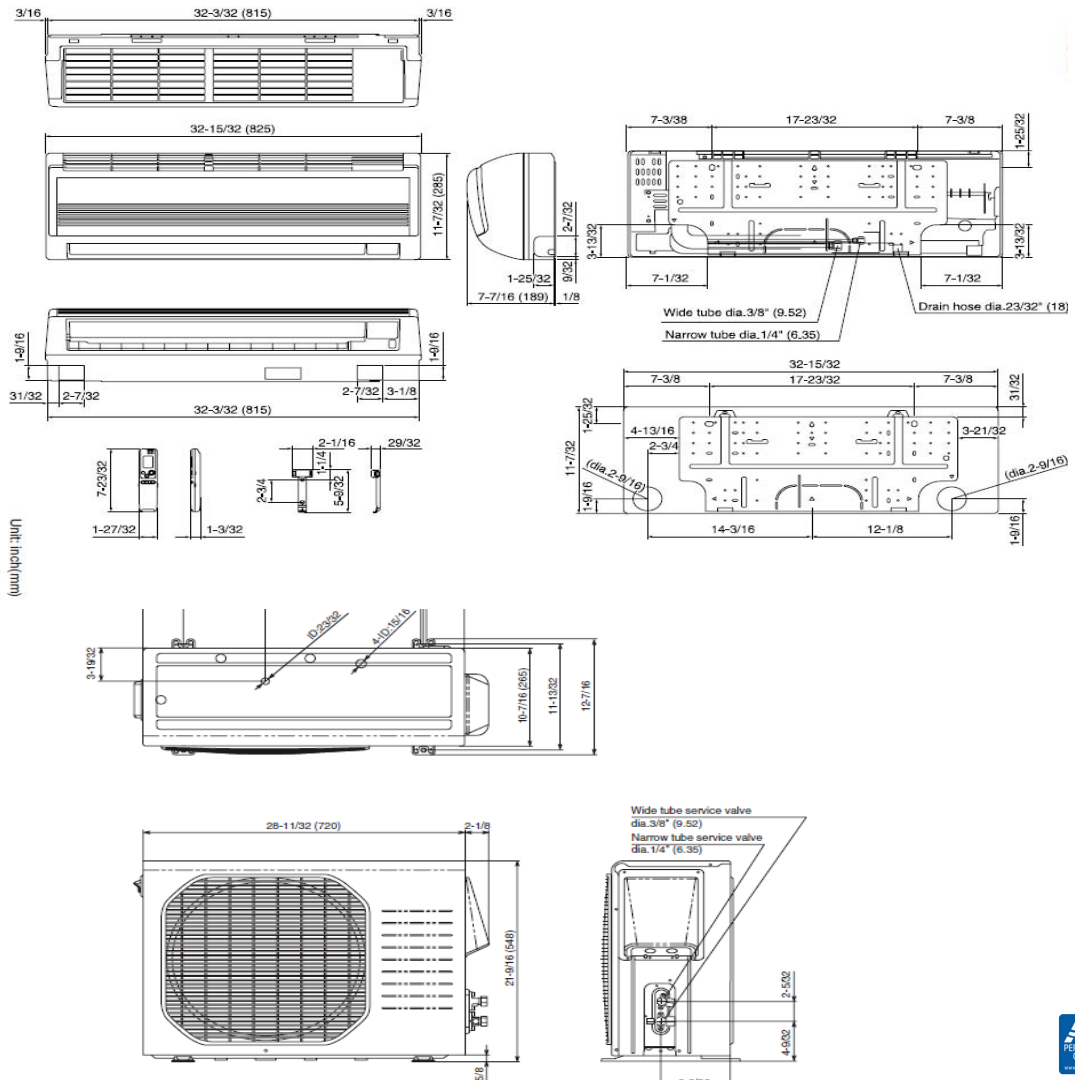

SANYO

Sanyo Commercial Solutions
A Division of SANYO North America
1300 Michael Drive
Wood Dale, IL 60191 USA
www.sanyohvac.com

