

# INSTALLATION AND MAINTENANCE INSTRUCTIONS 4SHP18LT Series Split System Heat Pump

## **⚠ WARNING**

The equipment covered in this manual is to be installed by trained and experienced service and installation technicians. Improper installation, modification, service, or use can cause electrical shock, fire, explosion, or other conditions which may cause personal injury, death, or property damage. Use appropriate safety gear including safety glasses and gloves when installing this equipment.

## **⚠ WARNING**

Risk of electrical shock. Disconnect all remote power supplies before installing or servicing any portion of the system. Failure to disconnect power supplies can result in property damage, personal injury, or death.

## **⚠ WARNING**

Installation and servicing of air conditioning equipment can be hazardous due to internal refrigerant pressure and live electrical components. Only trained and qualified service personnel should install or service this equipment. Installation and service performed by unqualified persons can result in property damage, personal injury, or death.

## **⚠ WARNING**

Sharp metal edges can cause injury. When installing the unit, use care to avoid sharp edges.

## TABLE OF CONTENTS

INSTALLATION .....	2
CONNECTION DIAGRAM .....	4
START-UP .....	13
OPERATION .....	18
MAINTENANCE .....	23
WARRANTY .....	28

Manufactured By  
**Allied Air Enterprises, Inc.**  
**A Lennox International Inc. Company**  
215 Metropolitan Drive  
West Columbia, SC 29170



\*48627D007\*

# INSTALLATION

## General

**Read this entire instruction manual, as well as the instructions supplied in separate equipment, before starting the installation. Observe and follow all warnings, cautions, instructional labels, and tags. Failure to comply with these instructions could result in an unsafe condition and/or premature component failure.**

These instructions are intended as a general guide only for use by qualified personnel and do not supersede any national or local codes in any way. The installation must comply with all provincial, state, and local codes as well as the National Electrical Code (U.S.) or Canadian Electrical Code (Canada). Compliance should be determined prior to installation.

4SHP18LT condensing units use R410A which is an ozone-friendly HFC refrigerant. The unit must be installed with a matching indoor coil and line set. A filter drier approved for use with R410A is installed in the unit.

**IMPORTANT:** This product has been designed and manufactured to meet ENERGY STAR criteria for energy efficiency when matched with appropriate coil components. However, proper refrigerant charge and proper air flow are critical to achieve rated capacity and efficiency. Installation of this product should follow the manufacturer's refrigerant charging and air flow instructions. **Failure to confirm proper charge and airflow may reduce energy efficiency and shorten equipment life.**

When servicing or repairing HVAC components, ensure the fasteners are appropriately tightened. Table 1 shows torque values for fasteners.

Torque Table	
Fastener	Torque
Stem Caps	8 ft. lbs.
Service Port Caps	8 ft. lbs.
Sheet Metal Screws	16 in. lbs.
#8 Machine Screws	16 in. lbs.
#10 Machine Screws	28 in. lbs.
Compressor Bolts	90 in. lbs.

Table 1

## Inspection of Shipment

Upon receipt of equipment, carefully inspect it for possible shipping damage. If damage is found, it should be noted on the carrier's freight bill. Take special care to examine the unit inside the carton if the carton is damaged. Any concealed damage discovered should be reported to the last carrier immediately, preferably in writing, and should include a request for inspection by the carrier's agent. If any damages are discovered and reported to the carrier **DO NOT INSTALL THE UNIT, as claim may be denied. Check the unit rating plate to confirm specifications are as ordered.**

## Location of Unit

Outdoor units operate under a wide range of weather conditions; therefore, multiple factors must be considered when positioning the unit. The unit must be positioned to give adequate clearances for sufficient airflow and servicing. Refer to Figure 1 for installation clearances.

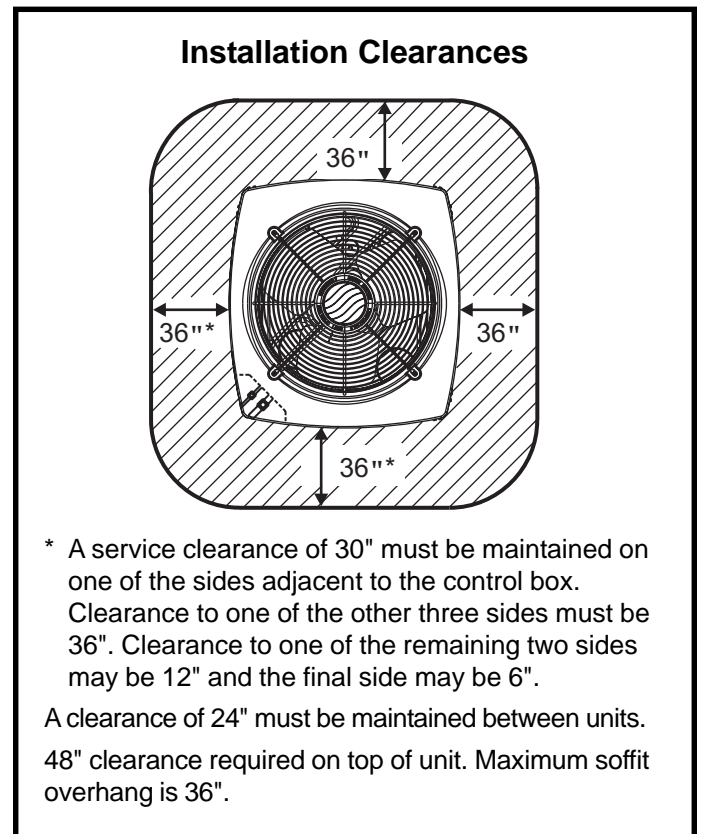

Figure 1

- Place a sound-absorbing material, such as Isomode under the unit if it will be installed in a location or position that will transmit sound or vibration to the living area or adjacent buildings..

- Install the unit high enough above the ground or roof to allow adequate drainage of defrost water and prevent ice buildup.
- In heavy snow areas, do not locate the unit where drifting snow will occur. The unit base should be elevated above the depth of average snows.

**NOTE:** Elevation of the unit may be accomplished by construction a frame using suitable materials. If a support frame is constructed, it must not block drain holes in unit base.

- When installed in areas where low ambient temperatures exist, locate unit so winter prevailing winds do not blow directly into outdoor coil.
- Locate unit away from overhanging roof lines which would allow water or ice to drop on, or in front of, coil or into unit.

**Slab Mounting**

When installing a unit at grade level, install on slab high enough above grade so that water from higher ground will not collect around the unit (See Figure 2). Slab should have a slope tolerance away from the building of 2° or 2" per 5'. This will prevent ice from building up under the unit during a defrost cycle. Refer to following roof mounting section for barrier construction if unit must face prevailing winter winds.

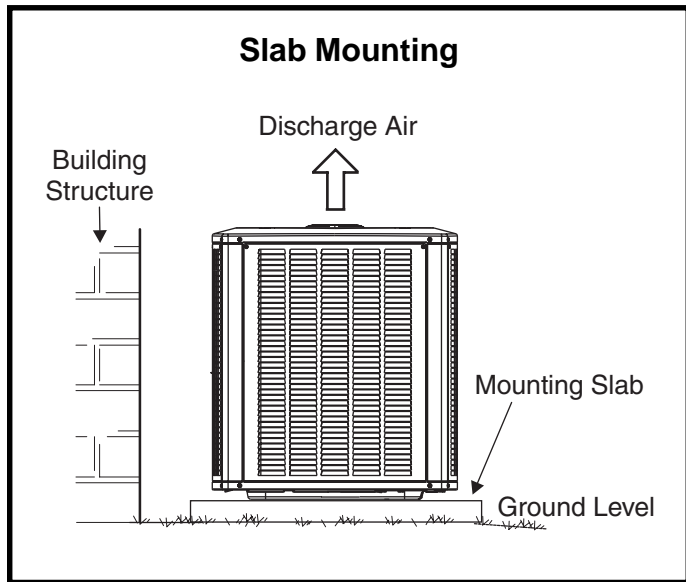

Figure 2

**Roof Mounting**

Install unit at a minimum of 6" above surface of the roof to avoid ice buildup around the unit. Locate the unit above a load bearing wall or area of the roof that can adequately support the unit. Consult local codes for rooftop applications.

If unit coil cannot be mounted away from prevailing winter winds, a wind barrier should be constructed (See Figure 3). Size the barrier at least the same height and width as the outdoor unit. Mount barrier 24" from the sides of the unit in the direction of the prevailing winds.

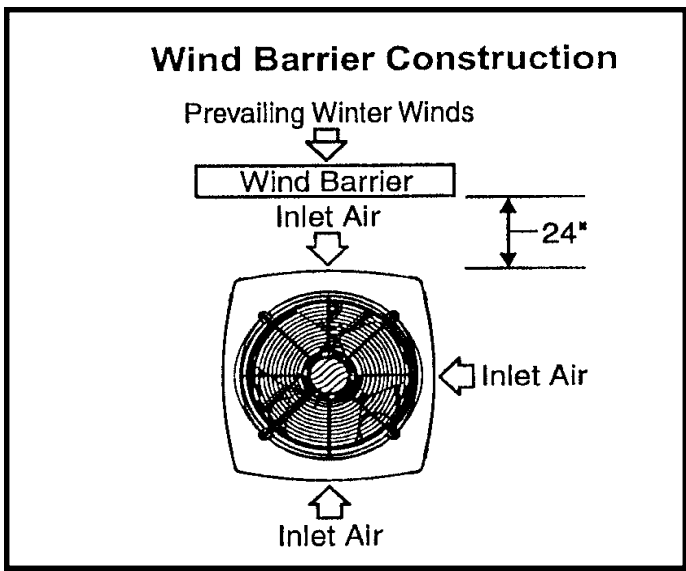

Figure 3

**Electrical Wiring**

All field wiring must be done in accordance with the National Electrical Code (NEC) recommendations, Canadian Electrical Code (CEC) and CSA Standards, or local codes, where applicable.

Refer to the furnace or blower coil installation instructions for additional wiring application diagrams and refer to unit rating plate for minimum circuit ampacity and maximum overcurrent protection size.

**⚠ WARNING**

Unit must be grounded in accordance with national and local codes. Failure to ground unit properly can result in personal injury or death.

**⚠ WARNING**

Line voltage is present at all components when unit is not in operation on units with single pole contactors. Disconnect all remote electric power supplies before opening access panel. Unit may have multiple power supplies. Failure to disconnect all power supplies could result in personal injury or death.

## Typical Field Wiring Diagram

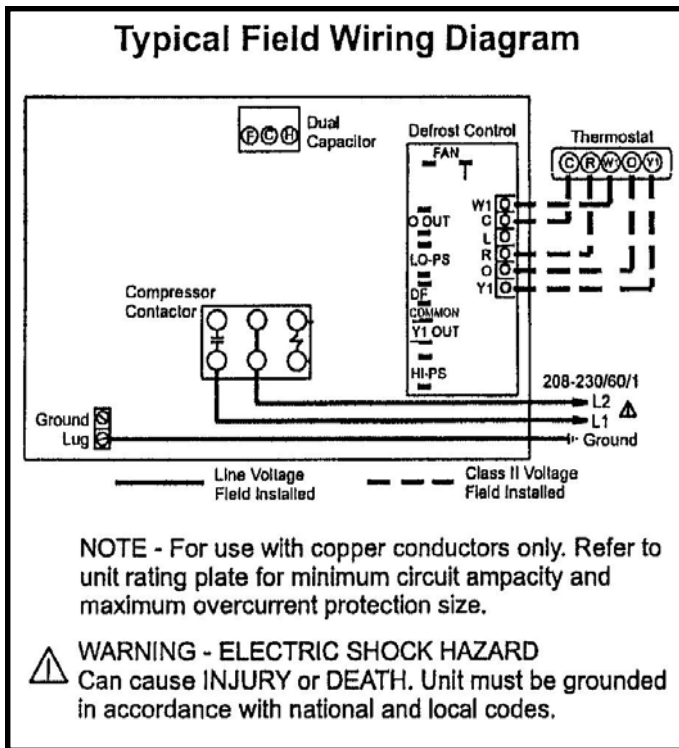

**Figure 4**

1. Install line voltage power supply to unit from a properly sized disconnect switch. Any excess high voltage field wiring should be trimmed or secured away from the low voltage field wiring.
2. Ground unit at unit disconnect switch or to an earth ground. To facilitate conduit, a hole is in the bottom of the control box. Connect conduit to the control box using a proper conduit fitting. Units are approved for use only with copper conductors. 24V Class II circuit connections are made in the low voltage junction box. Refer to Figure 4 for high voltage field wiring diagram. A complete unit wiring diagram is located inside the unit control box cover.
3. Install room thermostat on an inside wall that is not subject to drafts, direct sunshine, or other heat sources.
4. Install low voltage wiring from outdoor to indoor unit and from thermostat to indoor unit. (See Wire Diagram on page 27.)
5. Do not bundle any excess 24V control wire inside control box. Run control wire through installed wire tie and tighten wire tie to provide low voltage strain relief and to maintain separation of field-installed low and high voltage circuits.

## Refrigerant Piping

If the 4SHP18LT unit is being installed with a new indoor coil and line set, the refrigerant connections should be made as outlined in this section. If an existing line set and/or indoor coil will be used to complete the system, refer to this section as well as the section that follows entitled - **Flushing Existing Line Set and Indoor Coil.**

If this unit is being matched with an approved line set or indoor coil which was previously charged with R-22 refrigerant, the line set and coil must be flushed prior to installation. If the unit is being used with an existing indoor coil which was equipped with a liquid line which served as a metering device (RFCI), the liquid line must be replaced prior to the installation of the 4SHP18LT unit.

Field refrigerant piping consists of liquid and suction lines from the outdoor unit (sweat connections) to the indoor coil (flare or sweat connections).

Select line set diameters from Table 2 to ensure that oil returns to the compressor. Size vertical suction riser to maintain minimum velocity at minimum capacity. Recommended line length is 50' or less. If more than 50' line set is required, contact Technical Services. Table 2 shows the diameters for line sets up to 100' although vertical lift applications and trapping requirements need to be reviewed with Technical Services for line sets over 50'.

## Installing Refrigerant Line

During the installation of an air conditioning system, it is important to properly isolate the refrigerant line to prevent unnecessary vibration. Line set contact with the structure (wall, ceiling, or floor) may cause objectionable noise when vibration is translated into sound. As a result, more energy or vibration can be expected. Close attention to line set isolation must be observed.

Following are some points to consider when placing and installing a high-efficiency outdoor unit:

**Placement**

Be aware that some localities are adopting sound ordinances based on how noisy the unit is at the neighbor's home, not at the original installation. Install the unit as far as possible from the property line. When possible, do not install the unit directly outside a bedroom window. Glass has a very high level of sound transmission. Figure 5 shows how to place the outdoor unit and line set to reduce line set vibration.

**Line Set Isolation**

Illustrations on pages 6 and 7 demonstrate procedures which ensure proper refrigerant line set isolation. Figure 6 shows how to install line sets on horizontal runs. Figure 7 shows how to make a transition from horizontal to vertical. Figure 8 shows how to install line sets on vertical runs.

**Brazing Connection Procedure**

1. Cut ends of refrigerant lines square (free from nicks or dents). Debur the ends. The pipe must remain round; do not pinch end of line.
2. Before making line set connections, use dry nitrogen to purge the refrigerant piping. This will help to prevent oxidation and the introduction of moisture into the system.
3. Use silver alloy brazing rods (5% or 6% silver alloy for copper-to-copper brazing or 45% silver alloy for copper-to-brass or copper-to-steel brazing) which are rated for use with R410A refrigerant.
4. Remove the Schrader core assemblies before brazing to protect them from damage due to extreme heat. Replace the cores when brazing is complete.
5. Remove light maroon washers from service valves and shield light maroon stickers to protect them during brazing. Wrap a wet cloth around the valve body and copper tube stub to protect it from heat damage.

<b>Refrigerant Line Set Diameters (in.)</b>					
Liquid Line					
BTUH	Line Set Length and Size				
	12 ft.	25 ft.	50 ft.	75 ft.	100 ft.
18,000	3/8	3/8	3/8	3/8	3/8
24,000	3/8	3/8	3/8	3/8	3/8
30,000	3/8	3/8	3/8	3/8	1/2
36,000	3/8	3/8	3/8	7/8	1/2
42,000	3/8	3/8	3/8	1/2	1/2
48,000	3/8	3/8	3/8	1/2	1/2
60,000	3/8	3/8	3/8	1/2	1/2

Suction Line					
BTUH	Line Set Length and Size				
	12 ft.	25 ft.	50 ft.	75 ft.	100 ft.
18,000	3/4	3/4	3/4	3/4	3/4
24,000	3/4	3/4	3/4	3/4	7/8
30,000	3/4	3/4	3/4	7/8	7/8
36,000	7/8	7/8	7/8	7/8	1-1/8
42,000	7/8	7/8	7/8	1-1/8	1-1/8
48,000	7/8	7/8	7/8	1-1/8	1-1/8
60,000	1-1/8	1-1/8	1-1/8	1-1/8	1-1/8

**For installations exceeding 50', contact Technical Services.**

**Table 2**

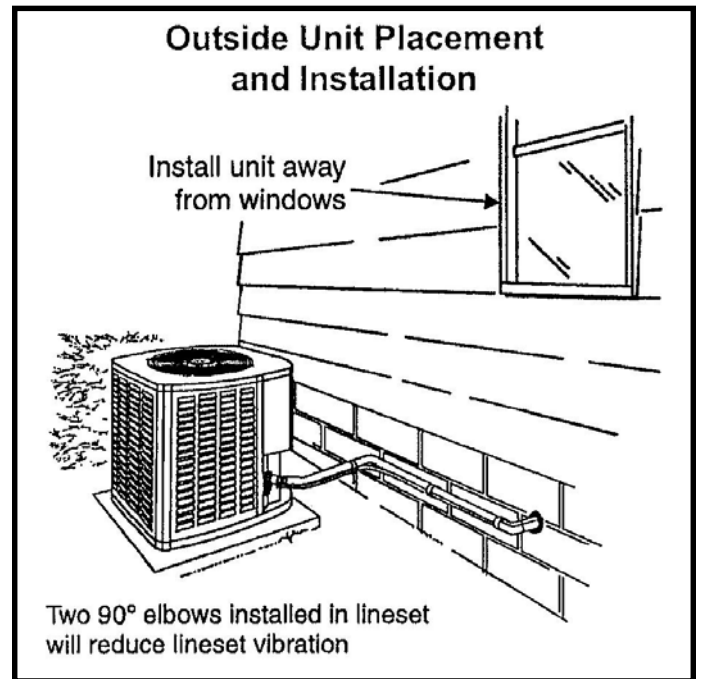

**Figure 5**

6. Braze the line set to the service valve. Quench the joints with water or a wet cloth to prevent heat damage to the valve core and opening port. **The tube end must stay bottomed in the fitting during final assembly to ensure proper seating, sealing, and rigidity.**

7. Install the thermal expansion valve which is sold separately and which is approved for use with R410A refrigerant in the liquid line at the indoor coil (see **Refrigerant Metering Device** on page 9).

**CAUTION**

When flushing existing line set and/or indoor coil, be sure to empty all existing traps. Residual mineral oil can act as an insulator, preventing proper heat transfer. It can also clog the thermal expansion valve, reducing system performance and capacity. Failure to properly flush system as explained in these instructions will void warranty.

**Refrigerant Line Sets: Installing Horizontal Runs**

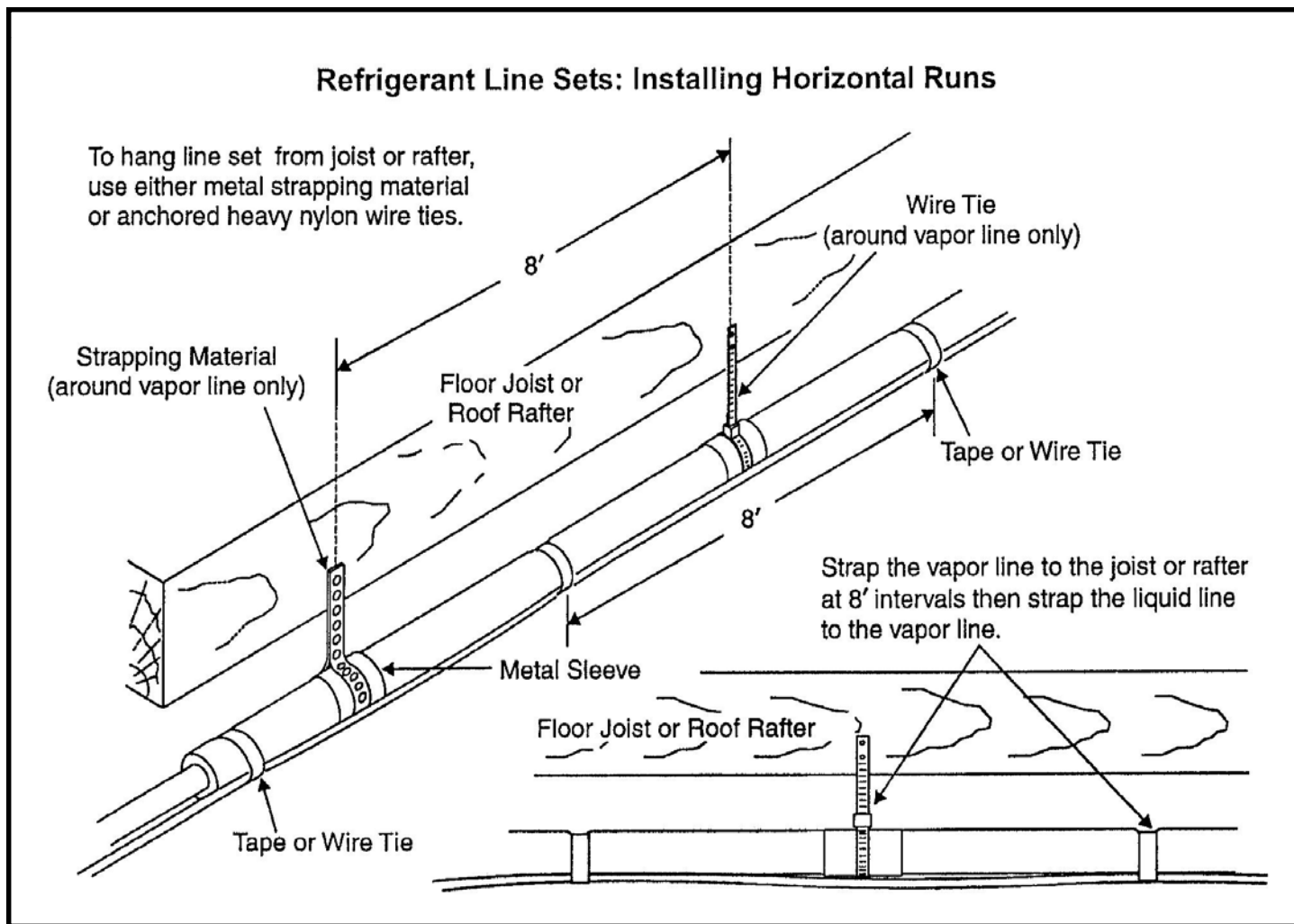

Figure 6

## Refrigerant Line Sets: Transition from Vertical to Horizontal

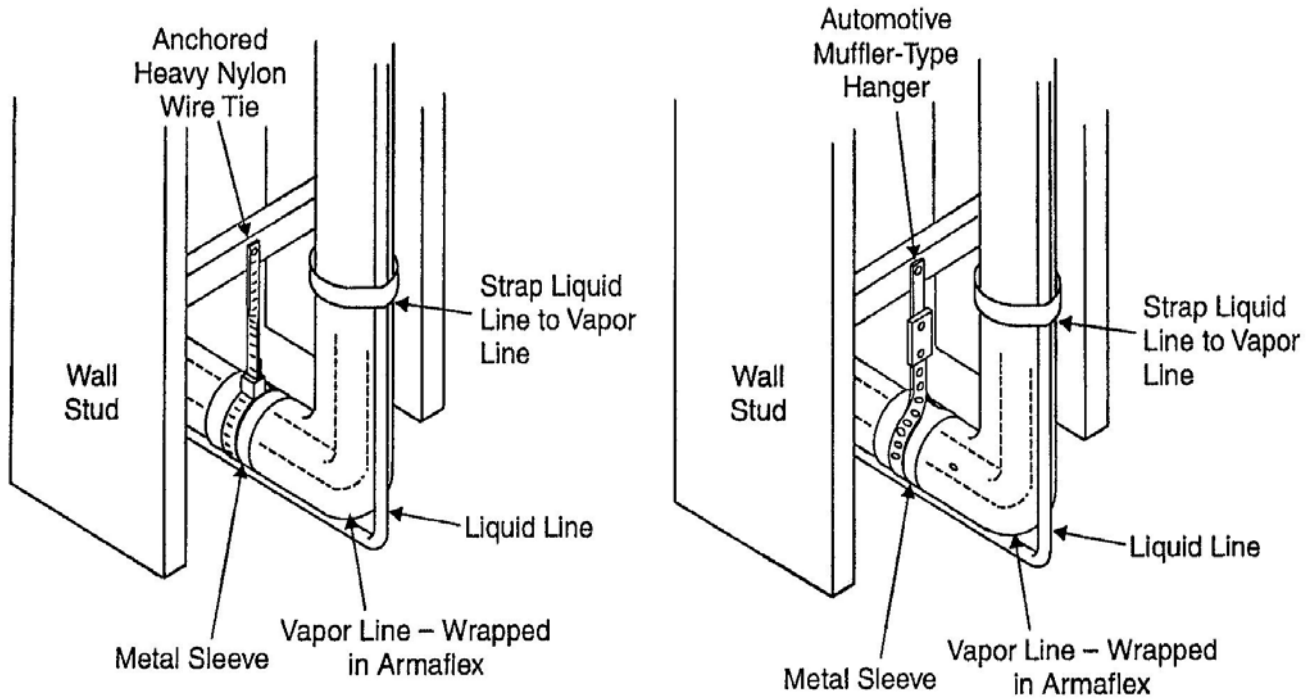

Figure 7

## Refrigerant Line Sets: Installing Vertical Runs (new construction shown)

NOTE: Similar installation practices should be used if line set is to be installed on exterior of outside wall.

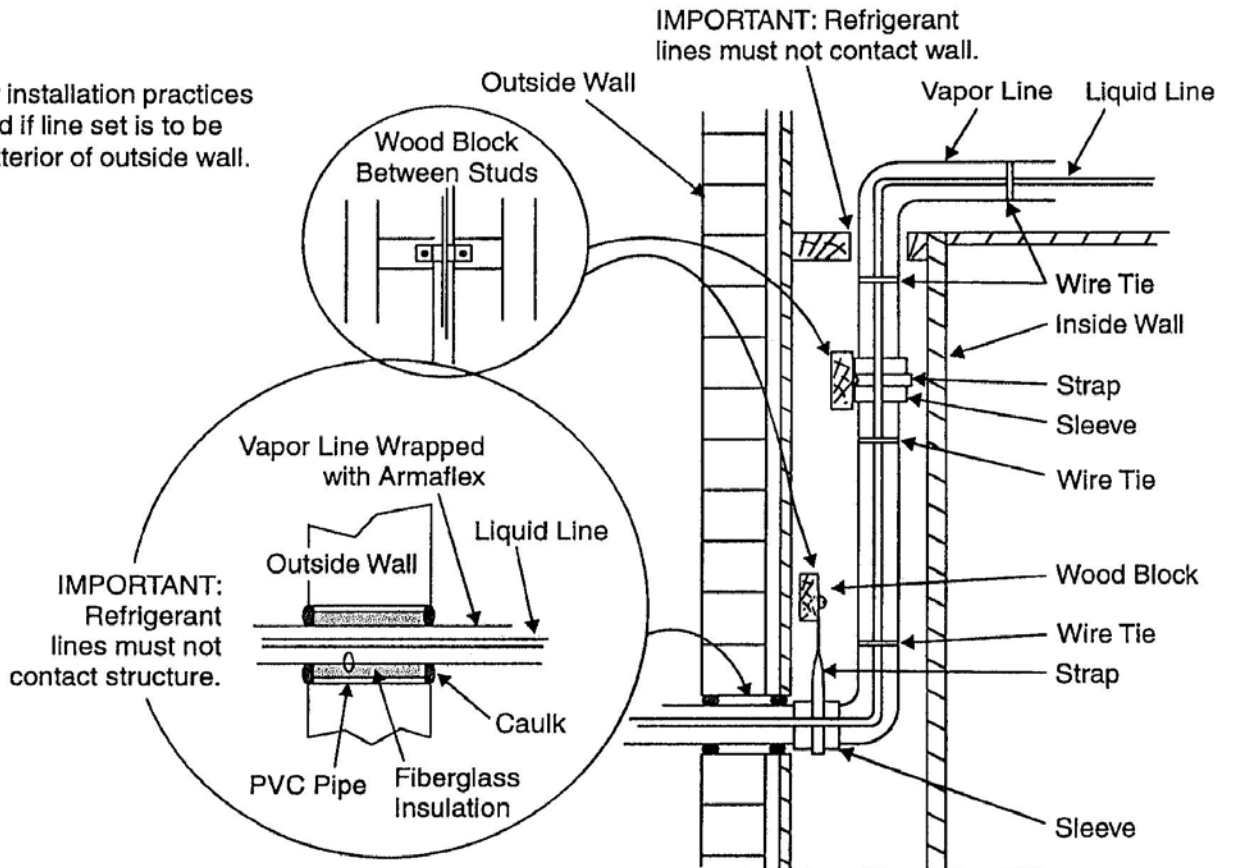

Figure 8

## Flushing Existing Line Set and Indoor Coil

**This procedure should not be performed on systems which contain contaminants, such as compressor burn out.**

### Required Equipment

The following equipment is needed to flush the existing line set and indoor coil (See Figure 9). Two clean R-22 recovery bottles, an oil-less recovery machine with a "pump down" feature, and two sets of gauges (one for use with R-22 and one for use with R410A).

### Flushing Procedure

**IMPORTANT:** The line set and/or indoor coil must be flushed with at least the same amount of refrigerant that previously charged the system. Check the charge in the flushing cylinder before flushing the unit.

1. Remove existing R-22 refrigerant using the appropriate procedure.

*If the existing outdoor unit is not equipped with shutoff valves, or if the unit is not operational AND the existing R-22 refrigerant will be used to flush the system:*

Disconnect all power to the existing outdoor unit. Connect the existing unit, a clean recovery cylinder, and the recovery machine according to the instructions provided with the recovery machine. Remove all R-22 refrigerant

from the existing system. Refer to the gauges after shutdown to confirm that the entire system is completely void of refrigerant. Disconnect the liquid and suction lines from the existing outdoor unit.

*If the existing outdoor unit is equipped with manual shutoff valves AND new R-22 refrigerant will be used to flush the system:*

Start the existing R-22 refrigerant system in cooling mode and close the liquid line valve. Pump all the existing R-22 refrigerant back into the outdoor unit.

(It may be necessary to bypass the low pressure switches to ensure complete refrigerant evacuation.)

When the low side system pressures reach 0 psig, close the suction line valve. Disconnect all power to the existing outdoor unit. Refer to the gauges after shutdown to confirm that the valves are not allowing refrigerant to flow back into the low side of the system. Disconnect the liquid and suction lines from the existing outdoor unit.

2. Remove the existing outdoor unit. Set the new R410A unit and follow the brazing connection procedure outlined previously on this page to make line set connections. **Do not install the R410A thermal expansion valve at this time.**

3. Make low voltage and line voltage connections to the new outdoor unit. **Do not turn on power to the unit or open the outdoor unit service valves at this time.**

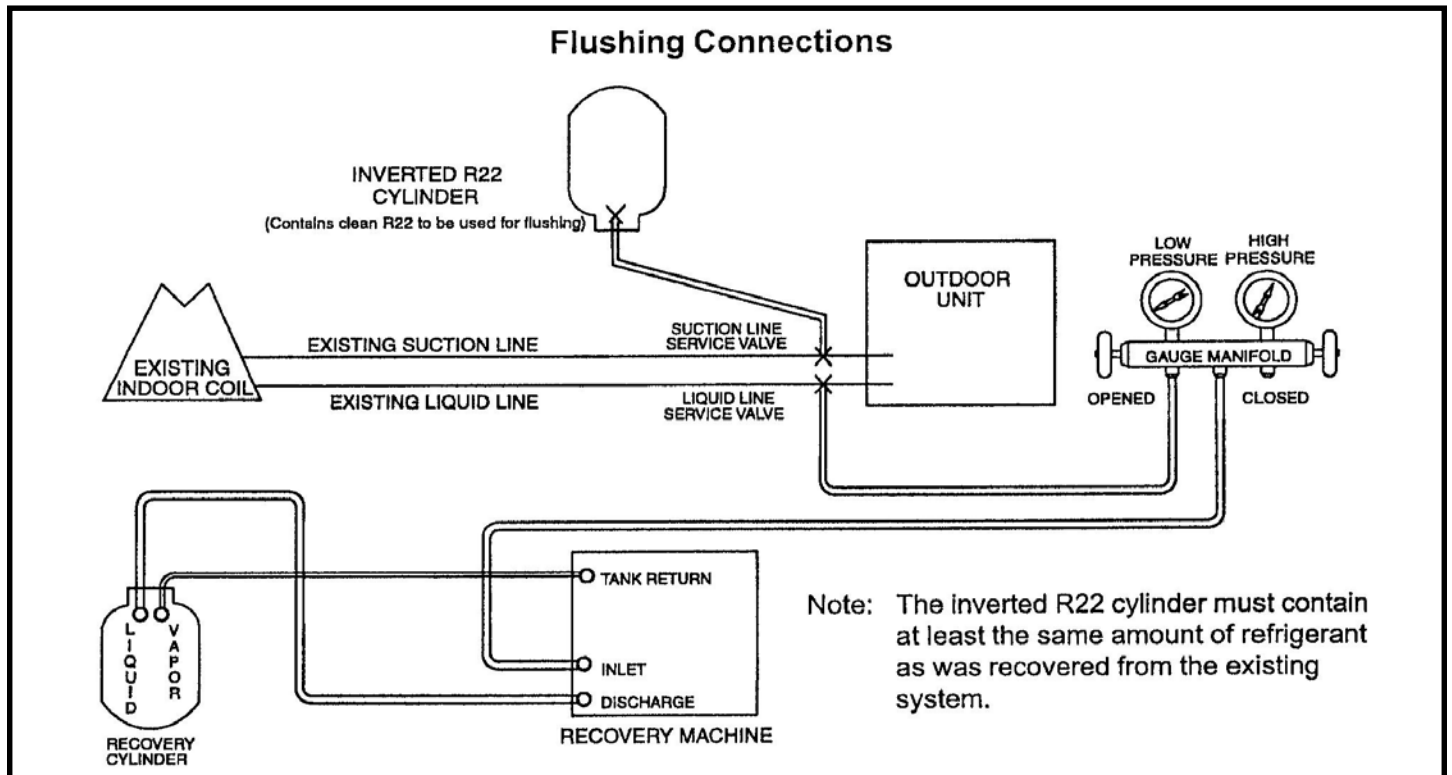

Figure 9



4. Remove the existing R-22 refrigerant flow control orifice or thermal expansion valve before continuing with flushing procedures. R-22 flow control devices are not approved for use with R410A refrigerant and may prevent proper flushing. Use a field-provided fitting to reconnect the lines.

5. Remove the pressure tap valve cores from the 4SHP18LT units service valves. Connect an R-22 cylinder with clean refrigerant to the suction service valve. Connect the R-22 gauge set to the liquid line valve and connect a recovery machine with an empty recovery tank to the gauge set.

6. Set the recovery machine for liquid recovery and start the recovery machine. Open the gauge set valves to allow the recovery machine to pull a vacuum on the existing system line set and indoor coil.

7. Invert the cylinder of clean R-22 and open its valve to allow liquid refrigerant to flow in to the system through the suction line valve. Allow the refrigerant to pass from the cylinder and through the line set and the indoor coil before it enters the recovery machine.

8. After all of the liquid refrigerant has been recovered, switch the recovery machine to vapor recovery so that all of the R-22 vapor is recovered. Allow the recovery machine to pull a vacuum on the system.

**NOTE:** A single system flush should remove all of the mineral oil from the existing refrigerant lines and indoor coil. A second flushing may be done (using clean refrigerant) if insufficient amounts of mineral oil were removed during the first flush. **After each system flush, allow the recovery machine to pull a vacuum on the system at the end of the procedure.**

9. Close the valve on the inverted R-22 cylinder and the gauge set valves. Pump the remaining refrigerant out of the recovery machine and turn the machine off.

10. Use nitrogen to break the vacuum on the refrigerant lines and indoor coil before removing the recovery machine, gauges, and R-22 refrigerant drum. Re-install pressure tap valve cores into the 4SHP18LT unit's service valves.

11. Install the fixed orifice (or thermal expansion valve approved for use with R410A refrigerant) in the liquid line at the indoor coil.

### Refrigerant Metering Device

4SHP18LT units are designed for use with TXV systems. Refer to the appropriate following section for information on installing the chosen refrigerant metering device.

An R410A system will not operate properly with an R-22 metering device.

Install the refrigerant metering device as shown in Figure 11. Do not twist cap tubes when loosening the seal nut from the orifice housing. Use wrench to back up the distributor.

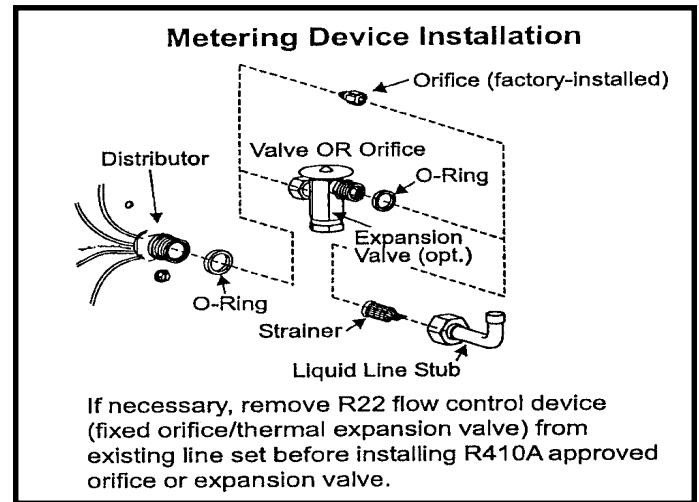

Figure 10

### Expansion Valve Systems

Expansion valves equipped with Chatleff-type fittings are available from the manufacturer. See Table 3 for proper TXV for each unit.

TXV Data	
Model	Part Number
4SHP18LT-24	H4TXV01
4SHP18LT-36	H4TXV02
4SHP18LT-48, -60	H4TXV03

Table 3

To install an expansion valve (See Figure 10 above):

1. Separate the distributor assembly and remove the piston orifice and used teflon seal. Insert nozzle end of the expansion valve along with a new teflon seal into the distributor and tighten to 20 - 30 ft. lbs. Use backup wrench on all wrench flats. **Overtightening will crush the teflon seal and may cause a leak.**
2. Attach liquid line portion of distributor assembly along with new teflon seal to the inlet of the expansion valve. Tighten to 20 - 30 ft. lbs. Use backup wrench on all wrench flats. **Overtightening will crush the teflon seal and may cause a leak.**

3. Connect the external equalizer line to the equalizer port on the suction line and tighten to 8 ft.lbs.
4. Strap the superheat sensing bulb to the suction header.

If installing an expansion valve on an indoor coil that previously used a fixed orifice, be sure to remove the existing fixed orifice. Failure to remove a fixed orifice when installing an expansion valve to the indoor coil will result in improper operation and damage to the system.

### Manifold Gauge Set

Manifold gauge sets used with systems charged with R410A refrigerant must be capable of handling the higher system operating pressures. The gauges should be rated for use with pressures 1 - 800 on the high side and a low side of 30" vacuum to 250 psi with dampened speed to 500 psi. Gauge hoses must be rated for use at up to 800 psi of pressure with a 4000 psi burst rating.

### Liquid and Suction Line Service Valves

The liquid line and suction line service valves (See Figure 11) and service ports are used for leak testing, evacuation, charging, and checking charge.

Each valve is equipped with a service port which has a factory-installed Schrader valve. A service port cap protects the Schrader valve from contamination and serves as the primary leak seal.

#### To Access the Schrader Port:

1. Remove the service port cap with an adjustable wrench.
2. Connect gauge to the service port.
3. When testing is completed, replace service port cap. Tighten finger tight, then an additional 1/6 turn.

#### To Open Liquid or Suction Line Service Valve:

Remove stem cap with an adjustable wrench.

Use service wrench with a hex-head extension to back the stem out counterclockwise as far as it will go. Use a 3/16" hex head extension for liquid line service valves and a 5/16" extension for suction line service valves.

Replace the stem cap. Tighten finger tight, then tighten an additional 1/6 turn.

#### To Close Liquid or Suction Line Service Valve:

1. Remove the stem cap with an adjustable wrench.
2. Use a service wrench with a hex-head extension to turn the stem clockwise to seat the valve. Tighten firmly.
3. Replace the stem cap. Tighten finger tight, then tighten an additional 1/6 turn.

### Suction Line (Ball Type) Service Valve

Suction line (ball type) service valves function the same way as the other valves; the difference is in the construction (See Figure 12).

The ball valve is equipped with a service port with a factory-installed Schrader valve. A service port cap protects the Schrader valve from contamination and serves as the primary seal.

### Leak Testing

After the line set has been connected to the indoor and outdoor units, the line set connections and indoor unit must be checked for leaks.

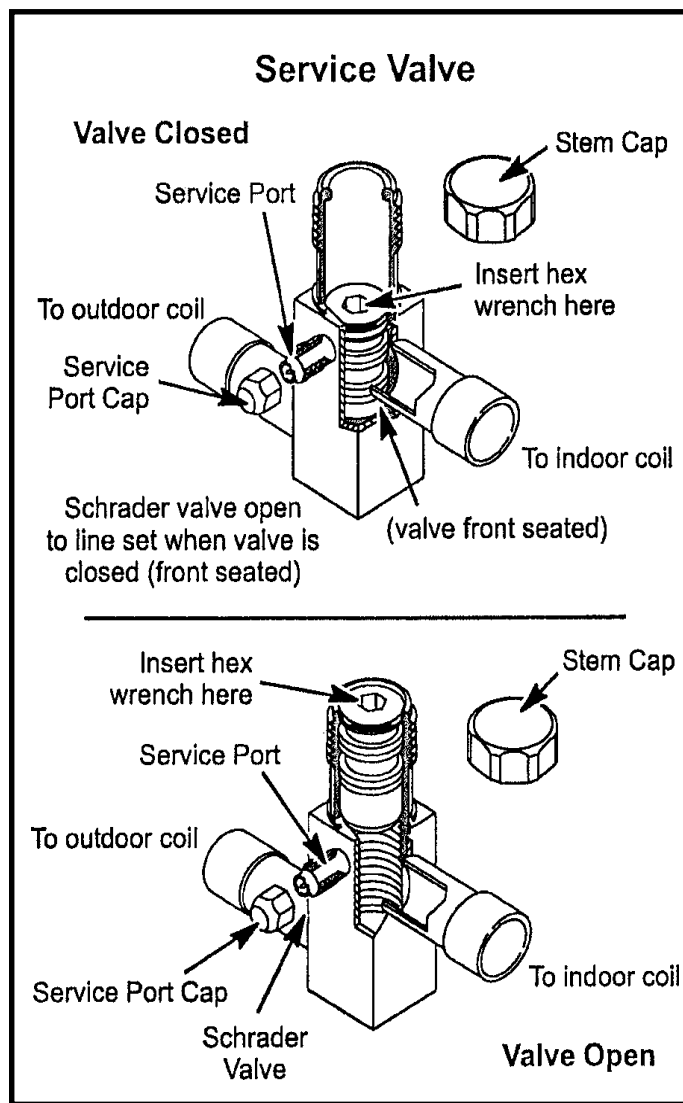

Figure 11

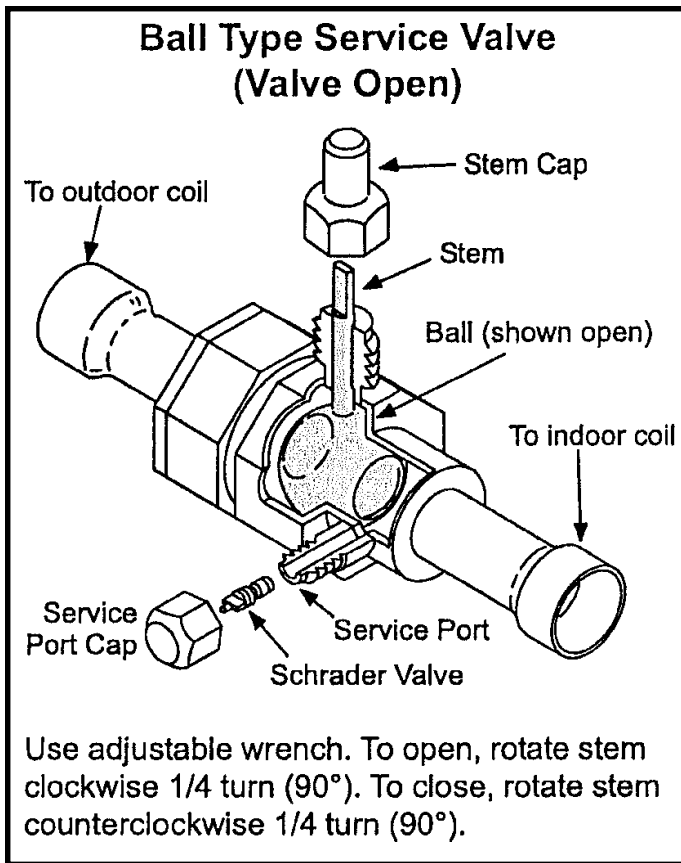

Figure 12

**⚠ WARNING**

Refrigerant can be harmful if inhaled. Refrigerant must always be used and recovered responsibly. Incorrect or irresponsible use of refrigerant can result in personal injury or death.

**⚠ WARNING**

Never use oxygen to pressurize refrigeration or air conditioning systems. Oxygen will explode on contact with oil and could cause personal injury or death.

**Using an Electronic Leak Detector**

1. Connect the high pressure hose of the manifold gauge set to the suction valve service port. (Normally the high pressure hose is connected to the liquid line port; however, connecting it to the suction ports helps to protect the manifold gauge set from damage caused by high pressure.)
2. With both manifold valves closed, connect the cylinder of R410A refrigerant. Open the valve on the R410A cylinder (vapor only).

3. Open the high pressure side of the manifold to allow R410A into the line set and indoor unit. Weigh in a trace amount of R410A. (A trace amount is a maximum of 2 oz. of refrigerant or 3 lbs. pressure.) Close the valve on the R410A cylinder and the valve on the high pressure side of the manifold gauge set. Disconnect the R410A cylinder.

4. Connect a cylinder of nitrogen with a pressure regulating valve to the center port of the manifold gauge set. **When using high pressure gas such as nitrogen for this purpose, be sure to use a regulator that can control the pressure down to 1 or 2 psig.**

5. Adjust nitrogen pressure to 150 psig. Open the valve on the high side of the manifold gauge set to pressurize the line set and the indoor coil.

6. After a short period of time, open a refrigerant port to make sure that an adequate amount of refrigerant has been added for detection (refrigerant requirements will vary with lengths). Check all joints for leaks. Purge nitrogen and R410A mixture. Correct any leaks and rechecks.

**Evacuation**

Evacuating the system of noncondensables is critical for proper operation of the unit. Noncondensables are defined as any gas that will not condense under temperatures and pressures present during operation of an air conditioning system. Noncondensables and water vapor combine with refrigerant to produce substances that corrode copper piping and compressor parts.

**⚠ WARNING**

Do Not use a compressor to evacuate a system. Avoid deep vacuum operation. Extremely low vacuums can cause internal arcing and compressor failure. Danger of equipment damage. Damage caused by deep vacuum operation will void warranty.

Use a thermocouple or thermistor electronic vacuum gauge that is calibrated in microns. Use an instrument that reads down to 50 microns.

1. Connect the manifold gauge set to the service valve ports as follows:
  - Low pressure gauge to suction line service valve
  - High pressure gauge to liquid line service valve.
2. Connect micron gauge.
3. Connect the vacuum pump (with vacuum gauge) to the center port of the manifold gauge set.

4. Open both manifold valves and start vacuum pump.
5. Evacuate the line set and indoor unit to a minimum of 500 microns or lower. During the early stages of evacuation, it is desirable to close the manifold gauge valve at least once to determine if there is a rapid rise in pressure. A rapid rise in pressure indicates a relatively large leak. If this occurs, the leak testing procedure must be repeated.
6. When 500 microns or lower is maintained, close the manifold gauge valves, turn off the vacuum pump, and disconnect the manifold gauge center port hose from the vacuum pump. Attach the manifold gauge center port hose to a nitrogen cylinder with pressure regulator set to 150 psig and purge the hose. Open the manifold gauge valves to break the vacuum in the line set and indoor unit. Close the manifold gauge valves.
7. Shut off the nitrogen cylinder and remove the manifold gauge hose from the cylinder. Open the manifold gauge valves to release the nitrogen from the line set and indoor unit.
8. Reconnect the manifold gauge to the vacuum pump, turn the pump on, and continue to evacuate the line set and indoor unit until 500 microns is maintained within a 20 minute period after shutting off the vacuum pump and closing the manifold gauge valves.
9. When the requirements above have been met, disconnect the manifold hose from the vacuum pump. Open the service valves to break the vacuum in the line set and indoor unit.

## START-UP

### ⚠ CAUTION

If unit is equipped with a crankcase heater, it should be energized 24 hours before unit start-up to prevent compressor damage as a result of slugging.

1. Rotate fan to check for frozen bearings or binding.
2. Inspect all factory and field-installed wiring for loose connections.
3. After evacuation is complete, open liquid line and suction line service valves to release refrigerant charge (contained in outdoor unit) into system.
4. Replace the stem caps and secure finger tight, then tighten an additional 1/6 of a turn.
5. Check voltage supply at the disconnect switch. The voltage must be within the range listed on the unit nameplate. If not, do not start equipment until the power company has been consulted and the voltage condition corrected.
6. Set thermostat for cooling demand, turn on power to indoor blower, and close the outdoor unit disconnect switch to start the unit.
7. Recheck unit voltage with unit running. Power must be within range shown on unit nameplate.

### Refrigerant Charging

This system is charged with R410A refrigerant which operates at much higher pressures than R-22. The liquid line drier provided with the unit is approved for use with R410A. Do not replace it with one designed for use with R-22. **This unit is NOT approved for use with coils which use capillary tubes as a refrigerant metering device.**

**R410A refrigerant cylinders are rose colored. Refrigerant should be added through the suction valve in the liquid state.**

**Certain R410A cylinders are identified as being equipped with a dip tube. These allow liquid refrigerant to be drawn from the bottom of the cylinder without inverting the cylinder. Do not turn this type of cylinder upside down to draw refrigerant.**

Units are factory charged with the amount of R410A refrigerant indicated on the unit rating plate. This charge is based on a matching indoor coil and outdoor coil with 15' line set. For varying lengths of line set, refer to Table 4 for refrigerant charge adjustment. A blank space is provided on the unit rating plate to list the actual field charge.

### Refrigerant Charge Adjustment

Liquid Line Set Diameter	Oz. Per 5 ft. adjust from 15 ft. line set*
3/8 in.	3 oz. Per 5 ft.

\* If line length is greater than 15 ft., add this amount.  
If line length is less than 15 ft., remove this amount.

Table 4

### ⚠ IMPORTANT

Mineral oils are not compatible with R410A. If oil must be added, it must be a polyolester oil.

If the system is void of refrigerant, clean the system using the procedure described below.

1. Use dry nitrogen to pressurized the system and check for leaks. Repair leaks, if possible.
2. Evacuate the system to remove as much of the moisture as possible.
3. Use dry nitrogen to break the vacuum.
4. Evacuate the system again.
5. Weigh the appropriate amount of R410A refrigerant (listed on unit nameplate) into the system.
6. Monitor the system to determine the amount of moisture remaining in the oil. Use a test kit to verify that the moisture content is within the kit's dry color range. It may be necessary to replace the filter drier several times to achieve the required dryness level. **If system dryness is not verified, the compressor will fail in the future.**

The outdoor unit should be charged during warm weather. However, applications arise in which charging must occur in the colder months. The method of charging is determined by the unit's **refrigerant metering device** and the **outdoor ambient temperature**.

Measure the liquid line temperature and the outdoor ambient temperature as outlined below:

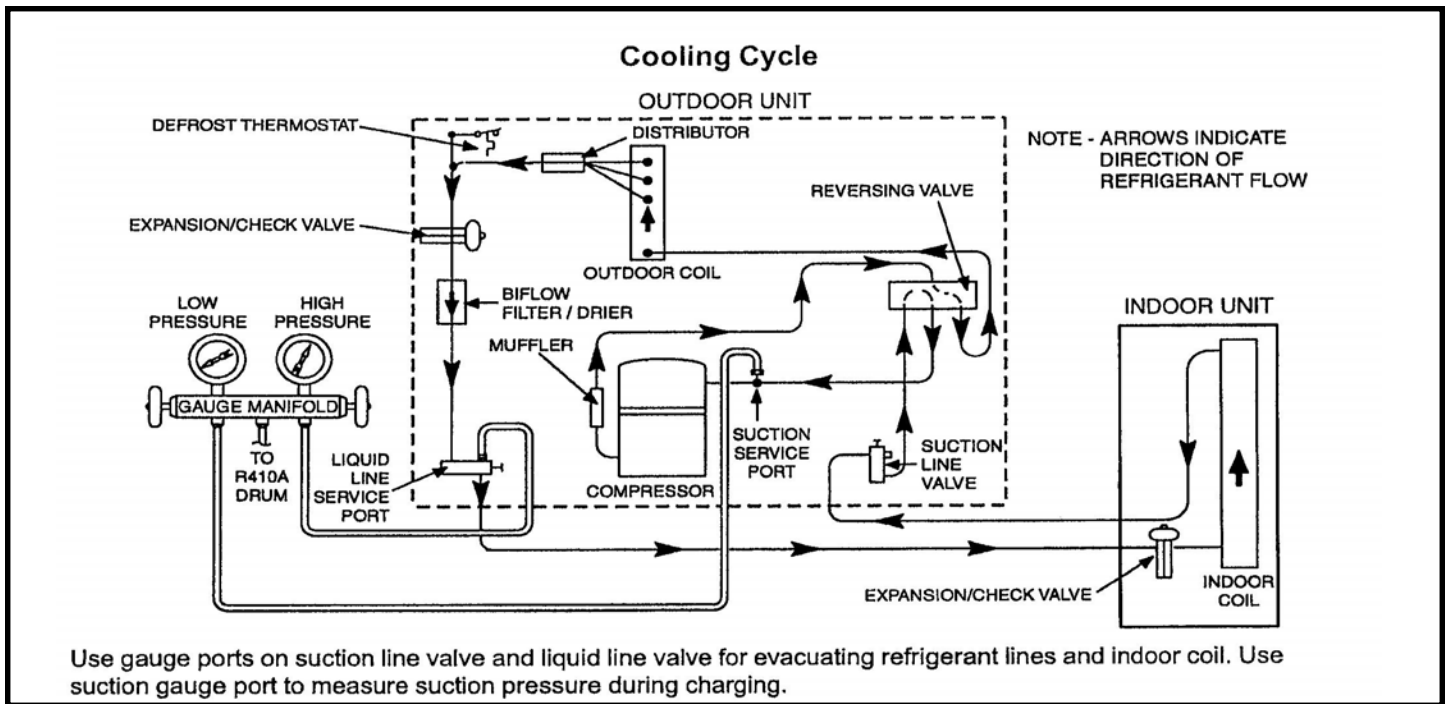

**Figure 13**

1. Connect the manifold gauge set to the service valve ports as follows (See Figure 13 above):

- Low pressure gauge to suction line service valve
- High pressure gauge to liquid line service valve

2. Close manifold gauge set valves. Connect the center manifold hose to an upright cylinder of R410A.

3. If room temperature is below 70°F, set the room thermostat to call for heat. This will create the necessary load for properly charging the system in the cooling cycle.

4. Use a digital thermometer to record the outdoor ambient temperature.

5. When the heating demand has been satisfied, switch the thermostat to cooling mode with a set point of 68°F. When pressures have stabilized, use a digital thermometer to record the liquid and suction line temperatures.

6. The outdoor temperature will determine which charging method to use. Proceed with the appropriate charging method.

**Charge Using Weigh-In Method (Fixed Orifice/TXV Systems) - Outdoor Temperatures Below 65°F**

If the system is void of refrigerant, or if the outdoor ambient temperature is cool, use the weigh-in method to charge the unit. Do this after any leaks have been repaired.

1. Recover the refrigerant from the unit.

2. Conduct a leak check, then evacuate as previously outlined.

3. Weigh in the charge according to the total amount shown on the unit nameplate.

If weighing facilities are not available or if unit is being charged during warm weather, use one of the following procedures.

**Charge Using Subcooling Method (Fixed Orifice/TXV Systems) - Outdoor Temperatures 65°F or Above**

If charging a fixed orifice or TXV system when the outdoor ambient temperature is 65°F or above, the subcooling method can be used to charge the unit.

1. With the manifold gauge hose still on the liquid service port and the unit operating stably, use a digital thermometer to check the liquid line temperature. For best results, use the same digital thermometer to check both the outdoor ambient and the liquid line temperatures.

2. At the same time, record the liquid line pressure reading.

3. Use the temperature/pressure chart (Table 5) to determine the saturation temperature for the liquid line pressure reading.

4. Subtract the liquid line temperature from the saturation temperature (according to the chart) to determine subcooling.

## R410A Temperature/Pressure Chart

Temp. °F	Pressure Psig	Temp. °F	Pressure Psig	Temp. °F	Pressure Psig
32	100.8	74	214.0	116	396.0
33	102.9	75	217.4	117	401.3
34	105.0	76	220.9	118	406.7
35	107.1	77	224.4	119	412.2
36	109.2	78	228.0	120	417.7
37	111.4	79	231.6	121	423.2
38	113.6	80	235.3	122	428.8
39	115.8	81	239.0	123	434.5
40	118.0	82	242.7	124	440.2
41	120.3	83	246.5	125	445.9
42	122.6	84	250.3	126	451.8
43	125.0	85	254.1	127	457.6
44	127.3	86	258.0	128	463.5
45	129.7	87	262.0	129	469.5
46	132.2	88	266.0	130	475.6
47	134.6	89	270.0	131	481.6
48	137.1	90	274.1	132	487.8
49	139.6	91	278.2	133	494.0
50	142.2	92	282.3	134	500.2
51	144.8	93	286.5	135	506.5
52	147.4	94	290.3	136	512.9
53	150.1	95	295.1	137	519.3
54	152.8	96	299.4	138	525.8
55	155.5	97	303.8	139	532.4
56	158.2	98	308.2	140	539.0
57	161.0	99	312.7	141	545.6
58	163.9	100	317.2	142	552.3
59	166.7	101	321.8	143	559.1
60	169.6	102	326.4	144	565.9
61	172.6	103	331.0	145	572.8
62	175.5	104	335.7	146	579.8
63	178.5	105	340.5	147	586.8
64	181.6	106	345.3	148	593.8
65	184.3	107	350.1	149	601.0
66	187.7	108	355.0	150	608.1
67	190.9	109	360.0	151	615.4
68	194.1	110	365.0	152	622.7
69	197.3	111	370.0	153	630.1
70	200.6	112	375.1	154	637.5
71	203.9	113	380.2	155	645.0
72	207.2	114	385.4		
73	210.6	115	390.7		
72	207.2	114	385.4		
73	210.6	115	390.7		

**Table 5**

- \_\_\_\_\_ ° Saturation Temperature °F
- \_\_\_\_\_ ° Liquid Line Temperature °F
- = \_\_\_\_\_ ° Subcooling Value °F

5. Compare the subcooling value with those shown in Table 7. If subcooling is greater than shown, recover some refrigerant. If subcooling is less than shown, add some refrigerant.

<b>Subcooling Values</b>				
Model	-24	-36	-48	-60
Temp. °F	7	7	4	5

**Table 6**

### Charge Using Approach Method (TXV System) - Outdoor Temperatures 65°F or Above

The following procedure is intended as a general guide and is for use on expansion valve systems only. For best results, indoor temperature should be 70°F to 80°F. Monitor system pressures while charging.

1. Record outdoor ambient temperature using a digital thermometer.
2. Attach high pressure gauge set and operate unit for several minutes to allow system pressures to stabilize.
3. Compare stabilized pressures with those provided in Table 8. Minor variations in these pressures may be expected due to differences in installations. **Significant differences could mean that the system is not properly charged or that a problem exists with some component in the system.** Pressures higher than those listed indicate that the system is overcharged. Pressures lower than those listed indicate that the system is undercharged. Verify adjusted charge using the approach method.
4. Use the same digital thermometer to check liquid line temperature.
5. Subtract the outdoor ambient temperature from the liquid line temperature to determine the approach temperature.

- \_\_\_\_\_ ° Liquid Line Temperature °F
- \_\_\_\_\_ ° Outdoor Ambient Temperature °F
- = \_\_\_\_\_ ° Approach Temperature °F

6. Compare the approach value with those shown in Table 9. If the values do not agree with those provided in Table 8, add refrigerant to lower the approach temperature or recover refrigerant from the system to increase the approach temperature.

**Check Charge Using Normal Operating Pressures**

Use Table 7 to perform maintenance checks. Table 7 is not a procedure for charging the system. Minor variations in these pressures may be due to differences in installations. Significant deviations could mean that the system is not properly charged or that a problem exists with some component in the system.

Approach Values for TXV Systems				
Model	-24	-36	-48	-60
Temp. °F	4	3	7	7

Approach value is the liquid line temperature minus the outdoor ambient temperature ("1°F).

Note: For best results, use the same digital thermometer to check both outdoor ambient and liquid temperatures.

**Table7**



## Normal Operating Pressures

### Low Capacity

Outdoor Coil Entering Air Temp. °F	24		36		48		60	
	L	S	L	S	L	S	L	S
65	208	139	212	147	223	142	236	139
75	257	144	254	147	265	144	278	141
85	297	148	295	148	306	147	321	142
95	342	153	337	149	348	149	363	144
105	387	158	379	150	390	151	405	146
115	431	162	420	151	431	154	448	147

### High Capacity

Outdoor Coil Entering Air Temp. °F	24		36		48		60	
	L	S	L	S	L	S	L	S
65	216	146	215	139	235	141	255	132
75	261	146	260	141	278	143	297	134
85	293	147	306	142	321	144	340	135
95	352	148	315	144	364	146	382	137
105	397	149	396	146	407	148	424	139
115	443	150	442	147	450	149	467	140

### Stage 1 Heat Low

Outdoor Coil Entering Air Temp. °F	24		36		48		60	
	L	S	L	S	L	S	L	S
40	292	104	303	95	313	92	333	89
50	312	110	320	112	333	108	359	105

### Stage 2 Heat High

Outdoor Coil Entering Air Temp. °F	24		36		48		60	
	L	S	L	S	L	S	L	S
20	268	55	284	63	281	59	312	58
30	298	73	302	78	287	73	334	71
40	327	91	321	94	307	87	357	85
50	357	109	340	110	328	101	380	98

L - Liquid      S- Suction

Values provided above are typical pressures. Indoor unit matchup, indoor air quality equipment, and indoor load will case pressures to vary.

**Table 8**

## OPERATION

Outdoor unit and indoor blower cycle on demand from the room thermostat. When the thermostat blower switch is moved to the ON position, the indoor blower operates continuously.

### Filter Drier

The unit is equipped with a large capacity bi-flow filter which keeps the system clean and dry. If replacement is necessary, replace with one of similar design and capacity. The replacement filter drier must be suitable for use with R410A refrigerant.

### Crankcase Heater

**If unit is equipped with a crankcase heater, it should be energized 24 hours before unit start-up to prevent compressor damage as a result of slugging.**

### Emergency Heat Function (Room Thermostat)

An emergency heat function is designed into some room thermostats. This feature is applicable when isolation of outdoor unit is required or when auxiliary electric heat is stage by outdoor thermostats. When the room thermostat is placed in the emergency heat position, the outdoor unit control circuit is isolated from power and the field-supplied relays bypass the outdoor thermostats. An amber indicating light simultaneously comes on to remind the homeowner that the unit is operating in the emergency heat mode.

Emergency heat is usually used during an outdoor shutdown, but it should also be used following a power outage if power has been off for over an hour and the outdoor temperature is below 50°F. System should be left in the emergency heat mode at least 6 hours to allow the crankcase heater sufficient time to prevent compressor slugging.

### Defrost System

The defrost system includes two components: the defrost thermostat and the defrost control.

#### Defrost Thermostat

The defrost thermostat is located on the liquid line between the check/expansion valve and the distributor. When the defrost thermostat senses 42°F or cooler, the thermostat contacts close and send a signal to the defrost control board to start the defrost timing. It also terminates defrost when the liquid line warms up to 70°F.

#### Defrost Control

The defrost control board includes the combined functions of time/temperature defrost control, defrost relay, diagnostic LEDs and terminal strip for field wiring connections (See Figure 14).

The control provides automatic switching from normal heating operation to defrost mode and back. During the compressor cycle (call for defrost), the control accumulates compressor run time at 30, 60, 90 minute field adjustable intervals. If the defrost thermostat is closed when the selected compressor run time interval ends, the defrost relay is energized and the defrost begins.

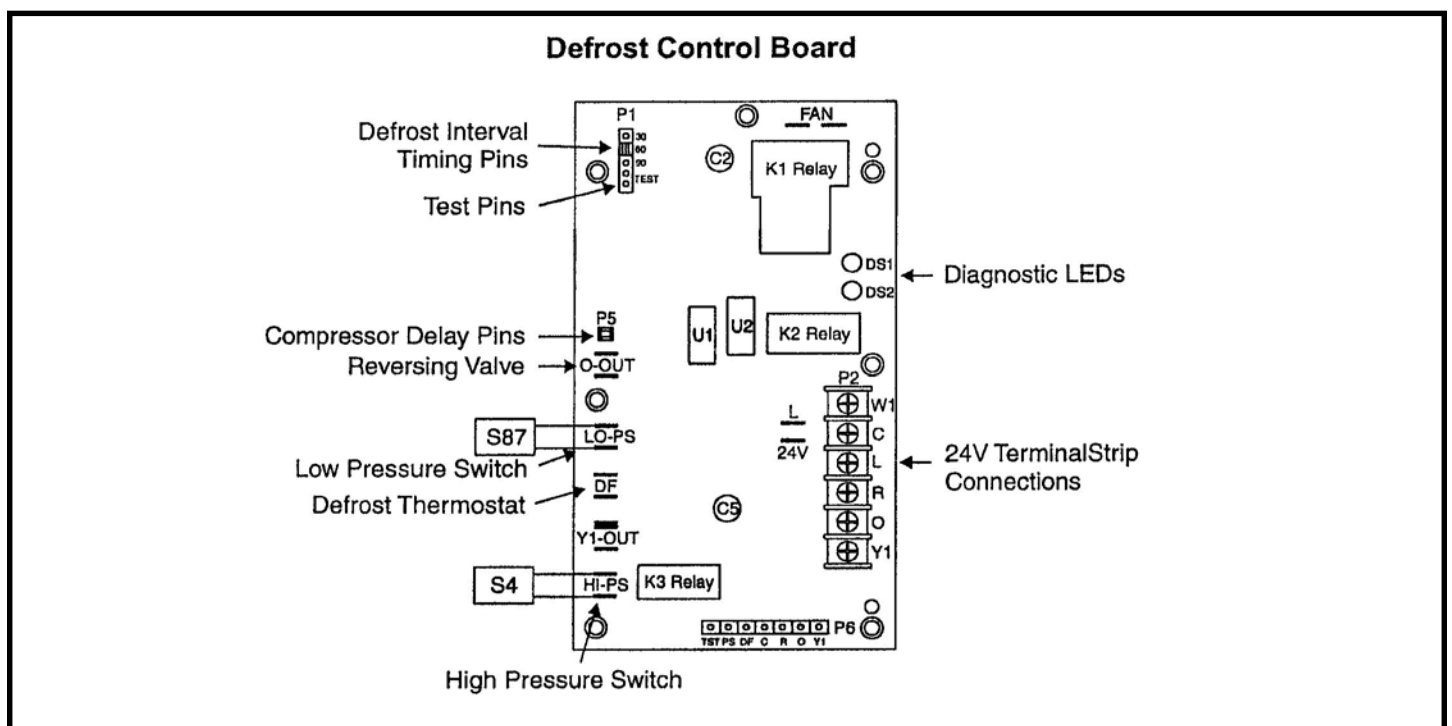

Figure 14

### **Defrost Control Timing Pins**

Each timing pin selection provides a different accumulated compressor run time period during one thermostat run cycle. This time period must occur before a defrost cycle is initiated. The defrost interval can be adjusted to 30 (T1), 60 (T2), or 90 (T3) minutes. The defrost timing jumper is factory installed to provide a 60 minute defrost interval. If the timing selector jumper is not in place, the control defaults to a 90 minute defrost interval. The maximum defrost period is 14 minutes and cannot be adjusted.

A test option is provided for troubleshooting. The test mode may be started any time the unit is in the heating mode and the defrost thermostat is closed or jumpered. If the jumper is in the TEST position at power up, the control will ignore the test pins. When the jumper is placed across the TEST pins for 2 seconds, the control will enter the defrost mode. If the jumper is removed before an additional 5 second period has elapsed (7 seconds total), the unit will remain in defrost mode until the defrost thermostat opens or 14 minutes have passed. If the jumper is not removed until after the additional 5 second period has elapsed, the defrost will terminate and the test option will not function again until the jumper is removed and reapplied.

### **Compressor Delay**

The defrost board has a field-selectable function to reduce occasional sounds that may occur while the unit is cycling in and out of the defrost mode. The compressor will be cycled off for 30 seconds going in and out of the defrost mode when the compressor delay jumper is removed.

**NOTE:** The 30-second “off” cycle is not functional when jumpering the TEST pins.

### **Time Delay**

The timed-off delay is 5 minutes long. The delay helps to protect the compressor from short cycling in case the power to the unit is interrupted or a pressure switch opens. The delay is bypassed by placing the timer select jumper across the TEST pins for 0.5 seconds.

### **Pressure Switch Circuit**

The defrost control includes two pressure switch circuits. A high pressure switch is connected to the board’s HI-PS terminals(See Figure 14). The low pressure, or loss-of-charge pressure, switch is connected to the LPS terminals.

During a single demand cycle, the defrost control will lock out the unit after the fifth time that the circuit is interrupted by an pressure switch wired to the control board. In addition, the diagnostic LEDs will indicate a locked-out pressure switch after the fifth occurrence of an open pressure switch (See Table 9). The unit will remain

locked out until power to the board is interrupted, then re-established, or until the jumper is applied to the TEST pins for 0.5 seconds.

**NOTE:** The defrost control board ignores input from the low pressure switch terminals as follows:

- During the TEST mode
- During the defrost cycle
- During the 90 seconds start-up period
- For the first 90 seconds each time the reversing valve switches heat/cool modes

**If the TEST pins are jumpered and the 5 minute delay is being bypassed, the LO-PS terminal signal is not ignored during the 90-second start-up period.**

### **Diagnostic LEDs**

The defrost board uses two LEDs for diagnostics. The LEDs flash a specific sequence according to the condition as shown in Table 9.

<b>Defrost Control Board Diagnostic LEDs</b>		
Mode	Green LED (DS2)	Red LED (DS1)
No Power to Board	Off	Off
Normal Operation/Power to Board	Simultaneous Slow Flash	
Anti-Short Cycle Lockout	Alternating Slow Flash	
Low Pressure Switch Fault	Off	Slow Flash
Low Pressure Switch Lockout	Off	On
High Pressure Switch Fault	Slow Flash	Off
High Pressure Switch Lockout	On	Off

**Table 9**

### System Diagnostic Module

4SHP18LT units contain a diagnostic module for troubleshooting heat pump system failures. By monitoring and analyzing data from the compressor and thermostat demand, the module can accurately detect the cause of electrical and system related failure without any sensors. If a system problem occurs, a flashing LED indicator communicates the failure code.

#### LED Description

**POWER LED (Green)** indicates voltage is present at the power connection of the module.

**ALERT LED (Yellow)** communicates an abnormal system condition through a unique flash code. The ALERT LED will flash a number of times consecutively, pause, and then repeat the process. The number of consecutive flashes correlates to a particular abnormal condition.

**TRIP LED (Red)** indicates there is a demand signal from the thermostat but no current to the compressor is detected by the module. The TRIP LED typically indicates the compressor protector is open or may indicate missing supply power to the compressor.

#### Interpreting the Diagnostic LEDs

When an abnormal system condition occurs, the diagnostic module displays the appropriate ALERT and/or TRIP LED. The yellow ALERT LED will flash a number of times consecutively, pause, and then repeat the process. To identify a flash code number, count the number of consecutive flashes. Refer to Table 10 below and Table 11 on page 20 for information on the flash codes.

<b>Flash Codes</b>		
<b>LED Status</b>	<b>Fault Description</b>	<b>Troubleshooting Information</b>
<b>POWER</b> (Green)	Module has power	Supply voltage is present at module terminals
<b>TRIP</b> (Red)	Thermostat demand signal Y1 is present, but the compressor is not running	<ol style="list-style-type: none"> <li>1. Compressor protector is open                             <ul style="list-style-type: none"> <li>* Check for high head pressure</li> <li>* Check compressor supply voltage</li> </ul> </li> <li>2. Outdoor unit power disconnect is open</li> <li>3. Compressor circuit breaker or fuse(s) is open</li> <li>4. Broken wire or connector is not making contact</li> <li>5. Low pressure switch open if present in system</li> <li>6. Compressor contactor has failed open</li> </ol>
<b>ALERT</b> (Yellow) Flash Code 1	<p style="text-align: center;"><b>Long Run Time</b> Compressor is running extremely long run cycles</p> <p style="text-align: center;"><b>(Not applicable on heat pump models)</b></p>	--
<b>ALERT</b> (Yellow) Flash Code 2	<p style="text-align: center;"><b>System Pressure Trip</b> Discharge or suction pressure out of limits or compressor overloaded</p>	<ol style="list-style-type: none"> <li>1. High head pressure                             <ul style="list-style-type: none"> <li>* Check high pressure switch if present in system</li> <li>* Check if system is overcharged with refrigerant</li> <li>* Check for non-condensable in system</li> </ul> </li> <li>2. Condenser coil poor air circulation (dirty, blocked, damaged)</li> <li>3. Condenser fan is not running                             <ul style="list-style-type: none"> <li>* Check fan capacitor</li> <li>* Check fan wiring and connectors</li> <li>* Check fan motor for failure or blockage</li> </ul> </li> <li>4. Return air duct has substantial leakage</li> <li>5. If low pressure switch present in system, check Flash Code 1 info</li> </ol>

**Table 10**

Every time the module powers up, the last ALERT LED flash code that occurred prior to shutdown is displayed for 60 seconds. The module will continue to display the previous flash code until the condition returns to normal or 21VAC is removed from the module. TRIP and ALERT LEDs flashing at the same time means control circuit voltage is too low for operation.

### 24VAC Power Wiring

The diagnostic module requires a constant nominal 24VAC power supply. The wiring to the module's R and C terminals must be directly from the indoor unit or thermostat. The module cannot be powered by R and C terminals on the defrost board without experiencing nuisance alerts.

### Flash Codes (cont.)

LED Status	Fault Description	Troubleshooting Information
<b>ALERT</b> (Yellow) Flash Code 3	<b>Short Cycling</b> Compressor is running only briefly	<ol style="list-style-type: none"> <li>1. Thermostat demand signal is intermittent</li> <li>2. Time delay relay or control board defective</li> <li>3. If high pressure switch present, go to Flash Code 2 info</li> <li>4. If low pressure switch present, go to Flash Code 1 info</li> </ol>
<b>ALERT</b> (Yellow) Flash Code 4	<b>Locked Rotor</b>	<ol style="list-style-type: none"> <li>1. Run capacitor has failed</li> <li>2. Low line voltage (contact utility if voltage at disconnect is low) * Check wiring connections</li> <li>3. Excessive liquid refrigerant in compressor</li> <li>4. Compressor bearings are seized *Measure compressor oil level</li> </ol>
<b>ALERT</b> (Yellow) Flash Code 5	<b>Open Circuit</b>	<ol style="list-style-type: none"> <li>1. Outdoor unit power disconnect is open</li> <li>2. Compressor circuit breaker or fuse(s) is open</li> <li>3. Compressor contactor has failed open * Check compressor contactor wiring and connectors * Check for compressor contactor failure (burned, pitted, or open) * Check wiring and connectors between supply and compressor * Check for low pilot voltage at compressor contactor coil</li> <li>4. High pressure switch is open and requires manual reset</li> <li>5. Open circuit in compressor supply wiring or connections</li> <li>6. Unusually long compressor protector reset time due to extreme ambient temperature</li> <li>7. Compressor windings are damaged * Check compressor motor winding resistance</li> </ol>
<b>ALERT</b> (Yellow) Flash Code 6	<b>Open Start Circuit</b> Current only in run circuit	<ol style="list-style-type: none"> <li>1. Run capacitor has failed</li> <li>2. Open circuit in compressor start wiring or connections * Check wiring and connectors between supply and the compressor S terminal</li> <li>3. Compressor start winding is damaged * Check compressor motor winding resistance</li> </ol>
<b>ALERT</b> (Yellow) Flash Code 7	<b>Open Run Circuit</b> Current only in start circuit	<ol style="list-style-type: none"> <li>1. Open circuit in compressor run wiring or connections * Check wiring and connectors between supply and the compressor R terminal</li> <li>2. Compressor run winding is damaged * Check compressor motor winding resistance</li> </ol>
<b>ALERT</b> (Yellow) Flash Code 8	<b>Welded Contactor</b> Compressor always runs	<ol style="list-style-type: none"> <li>1. Compressor contactor has failed closed</li> <li>2. Thermostat demand signal not connected to module</li> </ol>
<b>ALERT</b> (Yellow) Flash Code 9	<b>Low Voltage</b> Control circuit less than 17VAC	<ol style="list-style-type: none"> <li>1. Control circuit transformer is overloaded</li> <li>2. Low line voltage (contact utility if voltage at disconnect is low) * Check wiring conditions</li> </ol>

Table 11

### Thermostat Demand Wiring

The diagnostic module requires a thermostat demand signal to operate properly. The thermostat demand signal input, labeled Y on the module, should always be connected to the compressor contactor coil so that when the coil is energized, the demand signal input is 24VAC. When the coil is not energized, the demand signal input should be less than 0.5VAC.

### Miswired Module Codes

Depending on the system configuration, some ALERT flash codes may not be active. The presence of safety switches affects how the system alerts are displayed by the module.

Miswiring the diagnostic module will cause false LED codes. Table 12 Describes LED operation when the module is miswired and what troubleshooting action is required to correct the problem.

**Miswired Module Troubleshooting**

Miswired Module Indication	Recommended Troubleshooting Action
Green LED is not on, module does not power up.	Determine if both R and C module terminals are connected. Verify voltage is present at module's R and C terminals. Review 24VAC Power Wiring section on page 20 for R and C wiring.
Green LED intermittent, module powers up only when compressor runs.	Determine if R and Y terminals are wired in reverse. Verify module's R and C terminals have a constant source. Review 24VAC Power Wiring section on page 20 for R and C wiring.
TRIP LED is on but system and compressor check OK.	Verify Y terminal is connected to 24VAC at contactor coil. Verify voltage at contactor coils falls below 0.5VAC when off.
TRIP LED and ALERT LED flashing together.	Verify R and C terminals are supplied with 19-28VAC.
ALERT Flash Code 3 (Compressor Short Cycling) displayed incorrectly.	Verify Y terminal is connected to 24VAC at contactor coil. Verify voltage at contactor coil falls below 0.5VAC when off.
ALERT Flash Code 5, 6, or 7 (Open Circuit, Open Start Circuit, or Open Run Circuit) displayed incorrectly.	Check that compressor run and start wires are through module's current sensing holes. Verify Y terminal is connected to 24VAC at contactor coil. Verify voltage at contactor coil falls below 0.5VAC when off.
ALERT Flash Code 6 (Open Start Circuit) displayed for Code 7 (Open Run Circuit) or vice versa.	Check that compressor run and start wires are routed through the correct module sensing holes.
ALERT Flash Code 8 (Welded Contactor) displayed incorrectly.	Determine if module's Y terminal is connected. Verify Y terminal is connected to 24VAC at contactor coil. Verify 24VAC is present across Y and C when thermostat demand signal is present. If not, R and C are reverse wired. Verify voltage at contactor coil falls below 0.5VAC when off. Review Thermostat Demand Wiring on this page for Y and C wiring.

**Table 12**

## MAINTENANCE

### **WARNING**

Before performing maintenance operations on system, turn the electric power to unit OFF at disconnect switch(es). Unit may have multiple power supplies. Electrical shock could cause personal injury or death.

Before the start of each heating and cooling season, the following service checks should be performed by a qualified service technician.

Inspect and clean outdoor and indoor coils. The outdoor coil may be flushed with a water hose.

**NOTE:** It may be necessary to flush the outdoor coil more frequently if it is exposed to substances which are corrosive or which block air flow across the coil (such as pet urine, cottonwood seeds, etc...).

Visually inspect the refrigerant lines and coils for leaks.

Check wiring for loose connections.

Check voltage at the indoor and outdoor units (with units operating).

Check amperage draw at the outdoor fan motor, compressor, and indoor blower motor. Values should be compared with those given on unit nameplate.

Check, clean (or replace) indoor unit filters.

Check the refrigerant charge and gauge the system pressures.

Check the condensate drain line for free and unobstructed flow. Clean drain line, if necessary.

Adjust blower speed for cooling. Measure the pressure drop over the coil to determine the correct blower CFM.

Belt drive blowers: Check drive belt for wear and proper tensions.

If insufficient cooling is reported, the unit should be gauged and refrigerant charge checked (see **Refrigerant Charging** on page 13).

## HOMEOWNER INFORMATION

In order to ensure peak performance, your system must be properly maintained. Clogged filters and blocked airflow prevent your unit from operating at its most efficient level.

### **WARNING**

Turn all electric power to unit OFF at disconnect switch(es) before performing any maintenance operations on system. Unit may have multiple power supplies. Electrical shock could cause personal injury or death.

Ask your dealer to show you where the indoor unit's filter is located. It will be either at the indoor unit (installed internal or external to the cabinet) or behind a return air grille in the wall or ceiling in your home. Check the filter monthly and clean or replace it as needed.

Disposable filters should be replaced with a filter of the same type and size. If you are unsure of the filter you need for your system, contact your dealer.

Many indoor units are equipped with reusable foam filters. These filters can be cleaned with a mild soap and water solution. Rinse the filter thoroughly and let dry completely before returning to unit or grille.

**The filter and all access panels must be in place any time the unit is in operation.**

Some systems are equipped with an electronic air cleaner, designed to remove the majority of airborne particles from the air passing through the cleaner. If your system includes an electronic air cleaner, ask your dealer for maintenance instructions.

Inspect and clean indoor coil. The indoor evaporator coil is equipped with a drain pan to collect condensate formed as the system removes humidity from the inside air. Have your dealer show you the location of the drain line and how to check for obstructions. This also applies to an auxiliary drain, if one is installed.

#### ***Inspect and clean outdoor coil:***

Make sure no obstructions restrict airflow to the outdoor unit. Leaves, trash, or shrubs crowding the unit can cause it to work harder and use more energy. Keep shrubbery trimmed away from the unit and periodically check for debris which collects around the unit.

The outdoor coil may require frequent cleaning, depending on environmental conditions. Clean the outdoor coil with an unpressurized water hose to remove surface contaminants and debris. It may be necessary to flush the outdoor coil more frequently if it is exposed to

to substances which are corrosive or which block airflow across the coil (such as pet urine, cottonwood seeds, etc...).

#### **Heat Pump Operation**

Heat pump units have several characteristics you should be aware of:

Heat pumps satisfy heating demand by delivering large amounts of **warm air** into the living space. This is quite different from gas-fired, oil-fired, or electric furnaces which deliver lower volumes of considerably **hotter air** to heat the space.

Do not be alarmed if you notice frost on the outdoor coil in the winter months. Frost develops on the outdoor coil during the heating cycle when temperatures are below 45°F. An electronic control activates a defrost cycle lasting 5 to 15 minutes at preset intervals to clear the outdoor coil of the frost. A shift in sound type does occur during the defrost mode.

During the defrost cycle, you may notice steam rising from the unit. This is a normal occurrence. The thermostat may engage auxiliary heat during the defrost cycle to satisfy a heating demand. The unit will return to normal operation at the conclusion of the defrost cycle.

#### **In case of extended power outage....**

If the outdoor temperature is below 50°F and power to the outdoor unit has been interrupted for 6 hours or longer, observe the following when restoring power to the heat pump system.

Set the room thermostat selector to the "Emergency Heat" setting to obtain temporary heat for a minimum of 6 hours. This will allow system refrigerant pressures and temperatures enough time to return to a stabilized condition.

In the "Emergency Heat" mode, all heating demand is satisfied by auxiliary heat; heat pump operation is locked out. After a 6 hour "warmup" period, the thermostat can then be switched to the "Heat" setting and normal heat operation may resume.

#### **Thermostat Operation**

Though your thermostat may vary somewhat from the description below, its operation will be similar.

#### **Temperature Setting Levers**

Most heat pump thermostats have two temperature selector levers: one for heating and one for cooling. Set the levers or dials to the desired temperature setpoints for both heating and cooling. Avoid frequent temperature adjustment; turning the unit off and back on before pressures equalize puts stress on unit compressor.



### **Fan Switch**

In AUTO or INT (intermittent) mode, the blower operates only when the thermostat calls for heating or cooling. This mode is generally preferred when humidity control is a priority. The ON or CONT mode provides continuous indoor blower operation, regardless of whether the compressor or auxiliary heat are operating. This mode is required when constant air circulation or filtering is desired.

### **System Switch**

Set the system switch for heating, cooling, or auto operation. The auto mode allows the heat pump to automatically switch from heating mode to cooling mode to maintain predetermined comfort settings. Many heat pump thermostats are also equipped with an emergency heat mode which locks out heat pump operation and provides temporary heat supplied by the auxiliary heat.

### **Indicating Light**

Most heat pump thermostats have an amber light which indicates when the heat pump is operating in the emergency heat mode.

### **Temperature Indicator**

The temperature indicator displays the actual room temperature.

### **Programmable Thermostats**

Your system may be controlled by a programmable thermostat. These thermostats provide the added feature of programmable time-of-day set points for both heating and cooling. Refer to the user's information manual provided with your particular thermostat for operation details.

### **Preservice Check**

If your system fails to operate, check the following before calling for service:

Check to see that all electrical disconnect switches are ON.

Make sure the thermostat temperature selector is properly set.

Make sure the thermostat system switch is properly set.

Replace any blown fuses, or reset circuit breakers.

Make sure unit access panels are in place.

Make sure air filter is clean.

Locate unit model number and have it handy before calling.

## Start-Up and Performance Checklist

Job Name \_\_\_\_\_ Job No. \_\_\_\_\_ Date \_\_\_\_\_

Job Location \_\_\_\_\_ City \_\_\_\_\_ State \_\_\_\_\_

Installer \_\_\_\_\_ City \_\_\_\_\_ State \_\_\_\_\_

Unit Model No. \_\_\_\_\_ Serial No. \_\_\_\_\_

Service Technician \_\_\_\_\_ Nameplate Voltage \_\_\_\_\_

Rated Load Ampacity \_\_\_\_\_ Compressor Amperage \_\_\_\_\_ Outdoor Fan \_\_\_\_\_

Maximum Fuse or Circuit Breaker \_\_\_\_\_

Electrical Connections Tight?  Indoor Filter Clean?  Supply Voltage (Unit Off) \_\_\_\_\_

Indoor Blower RPM \_\_\_\_\_ S.P. Drop Over Indoor (Dry) \_\_\_\_\_

Outdoor Coil Entering Air Temperature \_\_\_\_\_ Voltage with Compressor Operating \_\_\_\_\_

Outdoor Fan Checked?

### **Cooling**

Liquid Line Pressure \_\_\_\_\_ Suction Line Pressure \_\_\_\_\_ Refrigerant Charge Checked?

### **Heating**

Liquid Line Pressure \_\_\_\_\_ Suction Line Pressure \_\_\_\_\_ Refrigerant Charge Checked?

Refrigerant Lines: Leak Checked?  Properly Insulated?

Service Valves: Fully Opened?  Caps Tight?

Thermostat: Calibrated?  Properly Set?  Level?

### **Sequence of Operation**

Heating Correct?  Cooling Correct?

# Wire Diagram

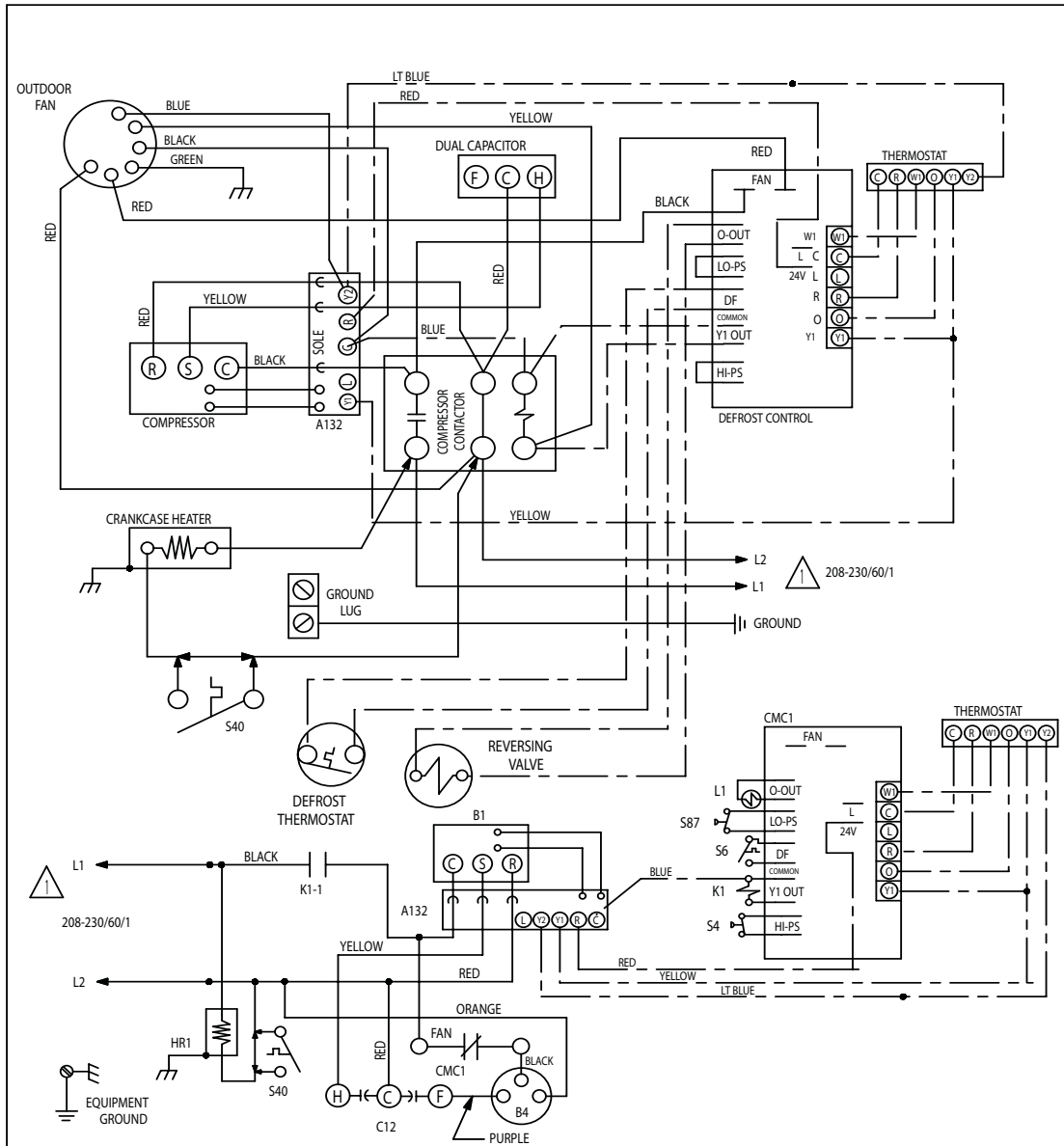

KEY	DESCRIPTION
A132	DIAGNOSTIC MODULE
B1	COMPRESSOR
B4	MOTOR - OUTDOOR FAN
C12	CAPACITOR - DUAL
CMC1	CONTROL-DEFROST
HR1	HEATER - COMPRESSOR
K1-1	CONTACTOR - COMPRESSOR
L1	VALVE - REVERSING
S4	SWITCH - HIGH PRESSURE
S6	SWITCH - DEFROST
S40	THERMOSTAT - CRANKCASE
S87	SWITCH - LOW PRESSURE



FOR USE WITH COPPER CONDUCTORS ONLY. REFER TO UNIT RATING PLATE FOR MINIMUM CIRCUIT AMPACITY AND MAXIMUM OVERCURRENT PROTECTION SIZE.  
 WARNING--  
 ELECTRIC SHOCK HAZARD, CAN CAUSE INJURY OR DEATH. UNIT MUST BE GROUNDED IN ACCORDANCE WITH NATIONAL AND LOCAL CODES.

DENOTES OPTIONAL COMPONENTS  
 LINE VOLTAGE FIELD INSTALLED  
 CLASS II VOLTAGE FIELD INSTALLED  
 24 VOLT FACTORY INSTALLED

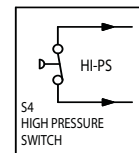
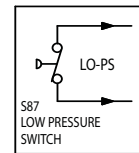

48630-001

# Limited Warranty

August 1, 1997

This warranty gives you specific legal rights and you may have other rights which vary from state/province to state/province.

**Warrantor: Allied Air Enterprises, Inc., 215 Metropolitan Drive, West Columbia, SC 29170**

Allied Air Enterprises, Inc. products are available under the following names: AirEase, Armstrong Air, Concord, Ducane

Subject to the limitations stated in this warranty, we warrant to the first buyer for use the residential heating, cooling or heat pump unit, when installed, operated and maintained as required by this warranty, to be free of defects in workmanship or material for a period of 10 years in residential installations (1 year in non-residential installations) from the time of installation. We will replace any defective component without cost or expense to you except for the costs of delivery and labor for removal and replacement of the defective component.

**The 4SHP18LT Series Heat Pumps carry a 10 year compressor warranty.**

## Warranty Begins

The warranty period begins when the installation is complete and the product is ready to operate. You must be able to verify this date whenever a warranty claim is made. Original bill of sale, installer's invoice or other similar document will suffice. If the beginning date cannot be verified, we will consider warranty coverage to begin 6 months after the date the product was shipped from our factory.

## Limitations on Implied Warranties

Implied warranties of merchantability or, to the extent applicable, fitness for a particular purpose are limited to 10 years, the same duration as the basic limited written warranty provided herein. Some states/provinces do not allow limitations on how long an implied warranty of merchantability or fitness lasts, so the above limitations or exclusions may not apply to you.

## Only Warranty

This written Limited Warranty is the only warranty made by the warrantor; this warranty is in lieu of and excludes all other warranties, express or implied. The warrantor does not authorize any person to provide any other warranty or to assume for it any further obligation in connection with the warranted product.

## What is NOT Covered

1. Cabinets or cabinet pieces.
2. Normal maintenance items such as filters, fan belts, fuses or other consumable items.
3. Damage caused by misuse, failure to maintain properly, accidents or acts of God.
4. External wiring, piping, venting or attachment of accessory products not integral to our product, including without limitation, humidifier, air cleaner, vent damper, thermostat or other mechanical devices not manufactured by the warrantor.
5. Products that have been operated in a corrosive atmosphere where a concentration of acids, halogenated hydrocarbons or other corrosive elements causes deterioration to metal surfaces or integral components. **NOTE:** Operation in a corrosive atmosphere is considered abuse and voids this warranty.
6. Products that have NOT been installed in accordance with our published installation instructions, applicable local, state/provincial or national codes, ACCA published standards.
7. Products that have NOT been installed by competent, qualified installers.
8. Products that have been moved from their original place of installation.

## Warranty on Replacement Components

Any replacement component furnished by us will assume the remaining (unused) portion of the Limited Warranty.

## Consequential Damages

The warrantor shall not be responsible for any consequential damages caused by any defect in the product. Some state/provinces do not allow the exclusion or limitations of incidental or consequential damages, so the above limitation or exclusion may not apply to you.

This product must be installed, used and cared for in accordance with the instruction manual. You are responsible for required periodic maintenance or service, such as changing or cleaning of air filters and lubrication or cleaning of components. Failure to properly install, operate or maintain your unit voids this warranty.