

WEIL-McLAIN

78

Installation

Start-up

Boiler Parts

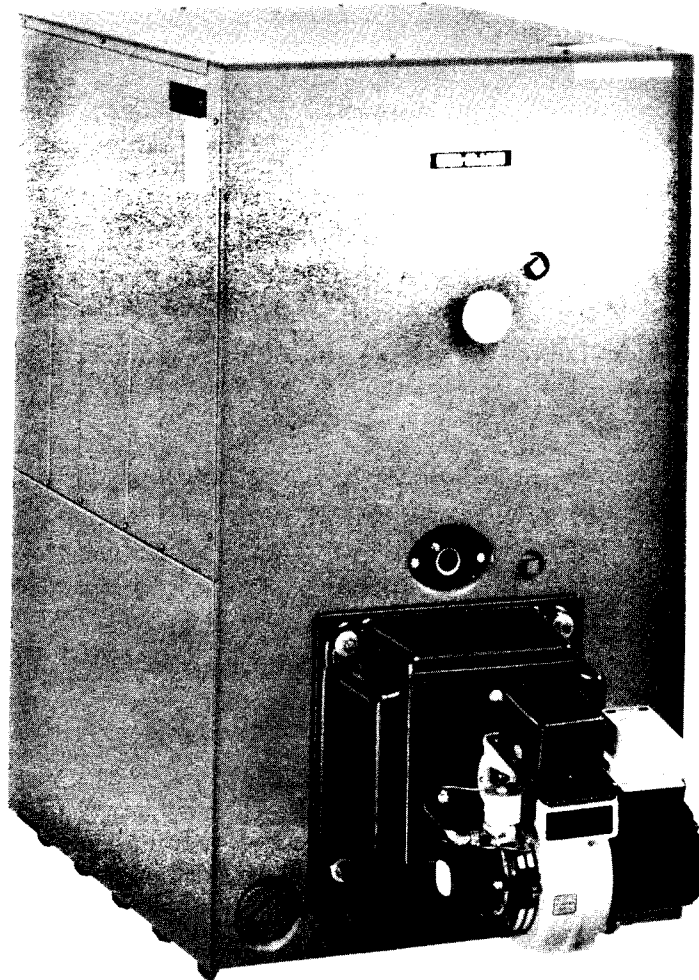

Boiler for Gas, Light Oil and Gas/Light Oil Fired Burners

Installer: Leave all documentation received with boiler and burner with unit for future reference.
User: Boiler and burner must be installed and serviced by a qualified service technician.

Part No. 550-141-705/0493DCP

Read This Page First

Hazard Definitions

The following defined terms are used throughout this manual to bring attention to the presence of hazards of various risk levels, or to important information concerning the life of the product.

DANGER

Indicates presence of hazard which will cause severe personal injury, death or substantial property damage if ignored.

WARNING

Indicates presence of hazard which can cause severe personal injury, death or substantial property damage if ignored.

CAUTION

Indicates presence of hazard which will or can cause minor personal injury or property damage if ignored.

NOTICE

Indicates special instructions on installation, operation, or maintenance which are important but not related to personal injury hazards.

When Calling or Writing about the Boiler

Please have model and series from boiler rating label and CP number(s) from boiler jacket or controls.

WARNING

Read all instructions before installing.
Failure to follow all instructions in proper order can cause severe personal injury, death or substantial property damage.

WARNING

Do not use petroleum-based cleaning or sealing compounds in boiler system.
Severe damage to system components can result, causing substantial property damage.

Table of Contents

Section A: Before Installing Boiler	4 - 5
Section B: Set Packaged Boiler or Block Assembly in Place	6
Section C: Assemble Block	7 - 12
Section D: Perform Hydrostatic Pressure Test	13
Section E: Connect Water Piping	14 - 15
Section F: Connect Steam Piping	16 - 19
Section G: Install Jacket	20
Section H: Pipe Tankless Heaters	20
Section I: Install Water Boiler Controls	21
Section J: Install Steam Boiler Controls	22 - 23
Section K: Connect Breeching and Venting Systems	24
Section L: Install Burner	25
Section M: Wiring and Fuel Piping	25
Section N: Make Final Adjustments	26 - 27
Section O: Data and Dimensions	28 - 29
Section P: Parts	30 - 31
Ratings	Back Cover

Section A: Before Installing Boiler

Installations must comply with:

- State, provincial and local plumbing, heating and electrical codes.
- Regulations of serving utilities.
- National codes where applicable.

Before selecting boiler location:

- Check for nearby connections to:
 - fuel supply
 - electrical power
 - system water or steam piping
 - venting systems - see page 24.
 - combustion and ventilation air supply - see "Provide combustion and ventilation air supply openings" below.
- Check area around boiler for and remove any combustible materials, gasoline and other flammable vapors and liquids.

WARNING

Failure to keep boiler area clear and free of combustible materials, gasoline and other flammable liquids and vapors can result in severe personal injury, death and substantial property damage.

Provide combustion and ventilation air openings:

WARNING

Do not install an exhaust fan in boiler room. Adequate combustion and ventilation air must be provided to assure proper combustion and prevent possibility of flue gas leakage and carbon monoxide emissions, causing severe personal injury or death.

Opening sizes must comply with state, provincial or local codes. In their absence, use the following when boiler is in a confined room:

- Provide two permanent openings in boiler room - one within 12 inches of ceiling, one within 12 inches of floor. Minimum dimension of each opening - 3 inches.
 - When all air is taken from within building, each opening should be at least one square inch/1,000 Btuh boiler input and freely connect with areas having adequate infiltration from outside.
 - When all air is taken from outdoors, each opening should connect directly or by ducts with outdoors or crawl or attic spaces that freely connect with outdoors and sized as listed below:
 - through outside wall or vertical ducts - at least one square inch/4,000 Btuh boiler input.
 - through horizontal ducts - at least one square inch/2,000 Btuh boiler input.
 - where ducts are used, they should be same cross-sectional area as free area of openings they are connected to.
 - Compensate for louver, grille or screen blockage when calculating free air openings. Refer to their manufacturer's instructions for size. If unknown, use:
 - wood louvers - 20-25% free air.
 - metal louvers or grilles - 60-75% free air.
 - screens - not less than 1/4 inch mesh.
- Lock louvers in open position, or interlock with equipment to prove open before boiler operation.

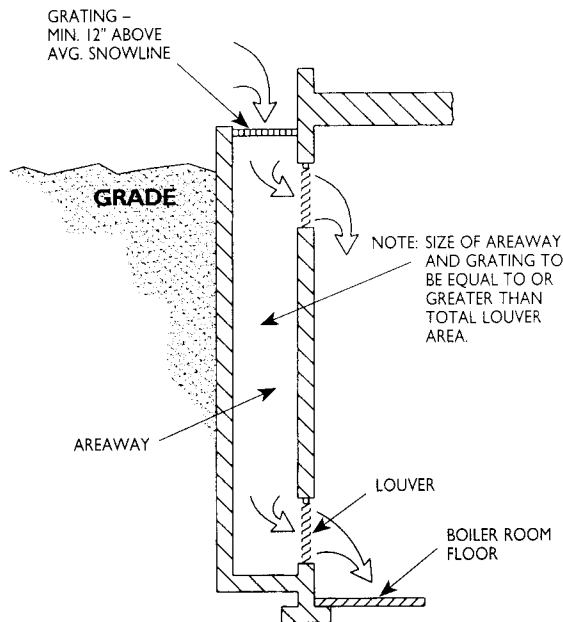

Combustion and Ventilation Air Openings
Boiler Room Below Grade
Figure 1

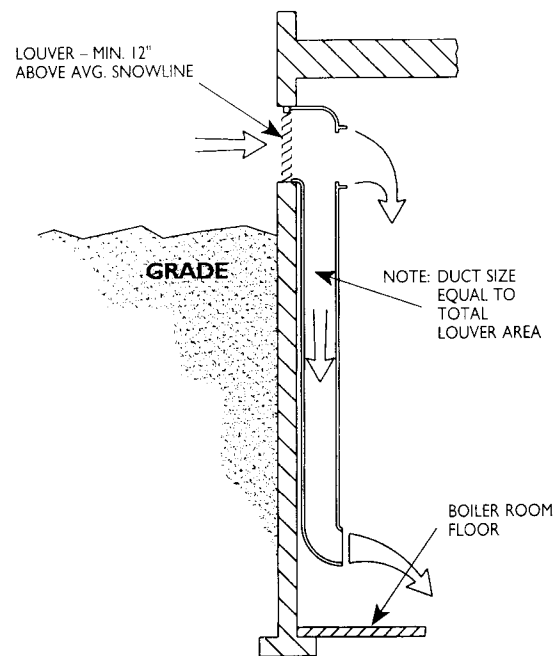

Combustion and Ventilation Air Openings
Boiler Room Partially or Completely Above Grade
Figure 2

Section A: Before Installing Boiler

CONT'D

Provide clearances for servicing around boiler:

- Back, for breeching - 30 inches
- Left side, for cleaning and tankless heater removal - 34 inches
- Allow sufficient space on remaining sides for cleaning, servicing and burner installation. See burner literature for length.
- Clearance from vent pipe to combustible materials:
 - singlewall vent pipe - 18 inches
 - doublewall vent pipe - refer to vent pipe manufacturer's recommendations for vent pipe clearances

Lay a foundation, if needed:

Floor construction and condition must be suitable for weight of boiler when filled with water. See back cover page for boiler/water weight.

A level concrete or brick foundation is required when:

- Floor could possibly become flooded;
- Non-level conditions exist.

BOILER FOUNDATION LENGTH TABLE			
BOILER MODEL	"L" INCHES	BOILER MODEL	"L" INCHES
378	23	878	58
478	30	978	65
578	37	1078	72
678	44	1178	79
778	51	1278	86

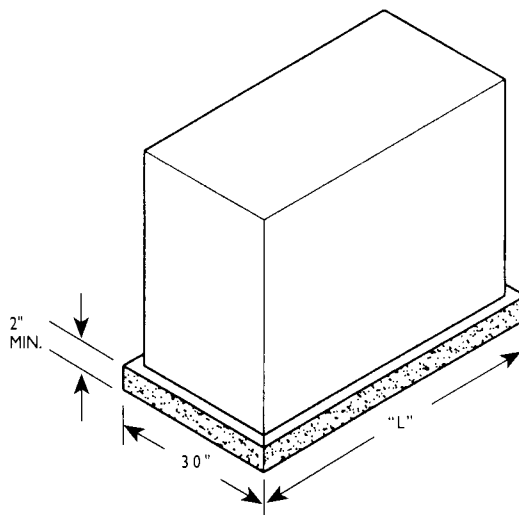

Boiler Foundation
Figure 3

Section B: Set Packaged Boiler or Block Assembly in Place

For packaged boiler:

1. Remove top jacket panel. Set aside until after boiler is piped.
2. Remove lag screws (2 in front, 2 in rear) from shipping rails.
3. Remove boiler from skid. Cables are already attached to block assembly. See Lifting Weight Chart.
 - Using crane - hook middle of each cable to eye of crane.
 - Using hoist - hook middle of each cable to hoist. Raise boiler off skid. Use pipe rollers under skid angles to roll boiler.
4. Place boiler in final position. Center boiler on foundation, if used.
5. Level boiler. Shim under skid angles, if necessary.
6. Cut off cables.

WARNING

Cables are not intended for long-term usage. Cables may corrode inside boiler, weakening their lifting strength. Failure to remove cables can result in severe personal injury, death or substantial property damage.

7. Proceed to "Section D: Perform Hydrostatic Pressure Test," page 13.

For block assembly:

1. Remove lag screws (2 in front, 2 in rear) from shipping rails.
2. Remove boiler from skid. Cables are already attached to block assembly. See Lifting Weight Chart.
 - Using crane - attach free end of cables to eye of crane.
 - Using hoist - attach free end of cables to hoist. Raise boiler off skid. Use pipe rollers under steel skid angles to roll boiler.

3. Place boiler in final position. Center boiler on foundation, if used.
4. Level boiler. Shim under skid angles, if necessary.
5. Cut off cables.

WARNING

Cables are not intended for long-term usage. Cables may corrode inside boiler, weakening their lifting strength. Failure to remove cables can result in severe personal injury, death or substantial property damage.

6. Inspect block assembly for disjointed sections. Check gas-tight seal of flue collector hood, flue collar and cleanout plates.

WARNING

Gas tight seal must be maintained to prevent possible flue gas leakage and carbon monoxide emissions, resulting in severe personal injury or death.

- a. Open damper in flue collar.
 - b. Check inside section assembly for any light passing through unsealed areas.
 - c. Mark all unsealed areas.
 - d. At unsealed areas, check for damaged gaskets, sealing rope not in place, loose bolts or nuts, or missing holddown clips. Correct all conditions and repeat step b. If unsealed areas still exist, contact your Weil-McLain distributor or sales office before continuing installation.
7. Proceed to "Section D: Perform Hydrostatic Pressure Test," page 13.

LIFTING WEIGHT CHART

BOILER MODEL	PACKAGED BOILER LBS.	ASSEMBLED BLOCK LBS.	BOILER MODEL	PACKAGED BOILER LBS.	ASSEMBLED BLOCK LBS.
378	1355	1150	878	2650	2325
478	1615	1385	978	2910	2560
578	1875	1620	1078	3165	2795
678	2130	1855	1178	3425	3030
778	2390	2090	1278	3680	3265

Section C: Assemble Block

WARNING

Sections are top heavy. Unbolted sections may fall if not supported, resulting in severe personal injury or death.

Install back refractory blanket:

1. Lay back section on floor with ports face up.
2. Apply water glass as an adhesive to blanket.
3. Press blanket against back target wall as shown in Figure 4.
4. Using knife, cut hole through blanket to expose observation port opening.

Prepare back section:

1. Apply 1/8" continuous bead of sealing rope adhesive in sealing rope grooves. See Figure 4. Do not get any adhesive on machined port surfaces.

2. Place 1/2" sealing rope in groove. Around curves, grasp at 1" intervals and push together. Do not stretch.

WARNING

Do not pre-cut rope. Gas tight seal must be maintained to prevent possibility of flue gas leakage and carbon monoxide emissions, causing severe personal injury or death.

3. Remove any grit from port machined surfaces with clean rag.

WARNING

Do not use petroleum-based cleaning or sealing compounds in boiler system. Severe damage to system components can result, causing substantial property damage.

4. Place 7-1/2" and 3-1/2" sealing rings in appropriate port openings. See Figure 4. If sealing ring slips out of groove, stretch ring gently for several seconds, then reposition in groove.

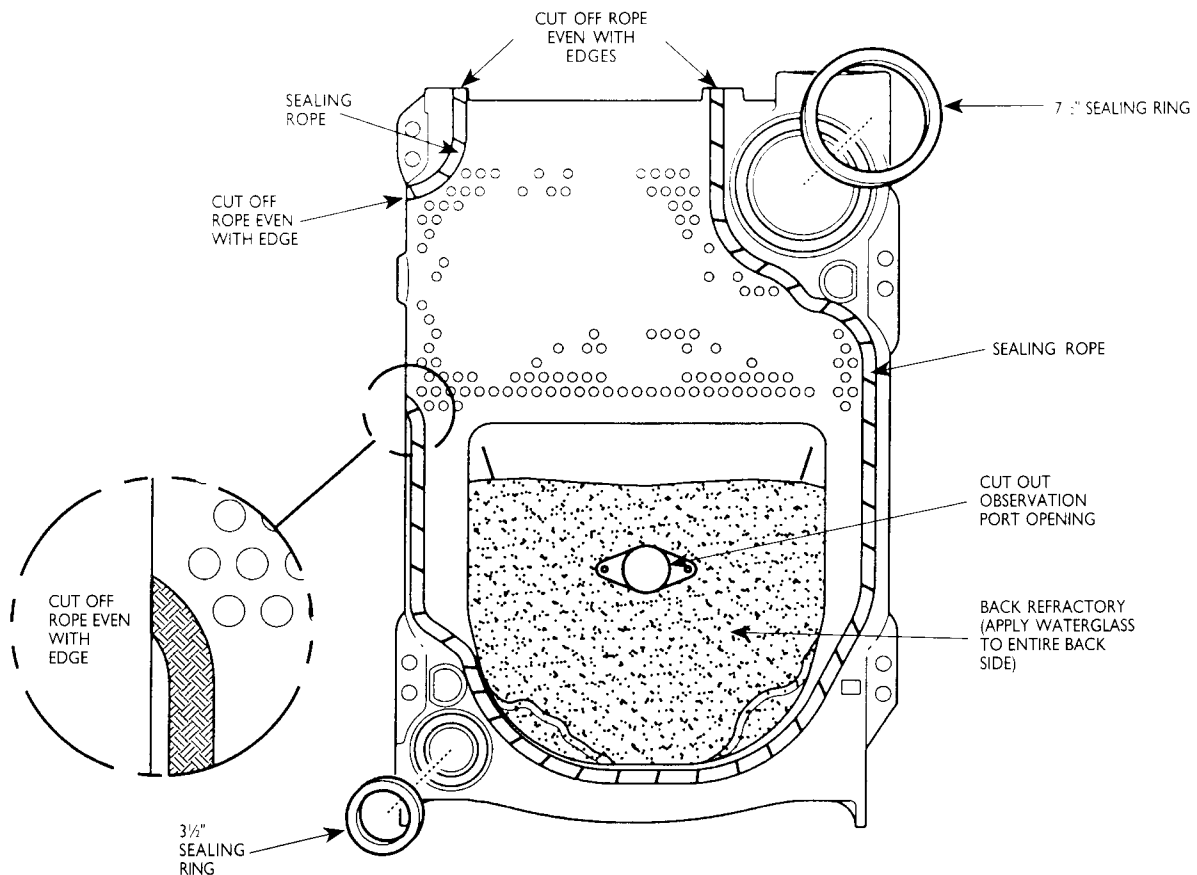

Figure 4

5. Apply continuous bead of silicone sealant no larger than 1/16" around entire outside edge of **outer** machined surface of port. Refer to Figure 5. **Do not apply silicone sealant on, next to or under sealing ring.**

WARNING

Silicone sealant applied as specified above prevents unburned oil vapors from coming in contact with sealing ring. Vapor contact can damage rings, resulting in severe damage to boiler and substantial property damage.

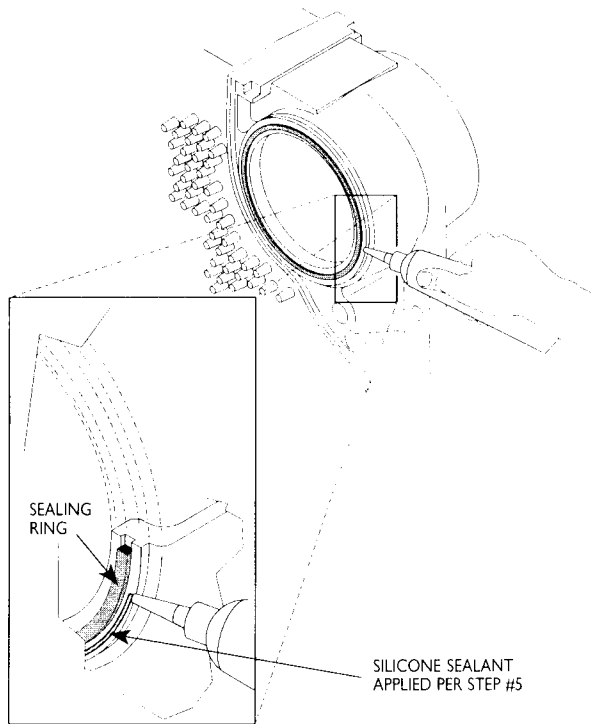

Figure 5

6. Position section upright on foundation (if used) and screw 3" pipe at least 22" long into 3" return tapping.
7. Place a block under pipe to hold section upright.

Prepare intermediate section:

WARNING

Sections are top heavy. Unbolted sections may fall if not supported, resulting in severe personal injury or death.

1. Remove and discard 3/8" diameter shipping tie rods.
2. Remove grit from port machined surfaces with clean rag.

WARNING

Do not use petroleum-based cleaning or sealing compounds in boiler system. Severe damage to system components can result, causing substantial property damage.

3. Position intermediate section so aligning lugs fit into sockets of next section. Refer to Figure 6.

4. Draw sections together until metal-to-metal contact is made around machined port openings (see Figure 6):
 - a. Oil threads on 4 draw rods. Install washer and nut on end to be tightened. Use nut only on other end.
 - b. Uniformly draw sections together, starting at washer/nut end.
 - c. Draw rods should be torqued to a range of 90 to 100 ft.-lbs. Do not back off draw rods.
 - d. Metal-to-metal contact will be achieved around port openings. See Figure 6. If gap does exist, it should be no greater than .032". Check with feeler gauge.
 - e. If for any reason, gap around machined port opening exceeds .032", check for rope extending from rope grooves, dirt on port openings or sockets, or misaligned lugs. If corrections are made and gap still exists, contact your Weil-McLain distributor or sales office before continuing installation.

CAUTION

After erecting first intermediate section, check both sections for plumb. Failure to plumb sections can cause misaligned piping and breaching, resulting in minor property damage.

6. Repeat steps 1 - 5 from "Prepare back section."

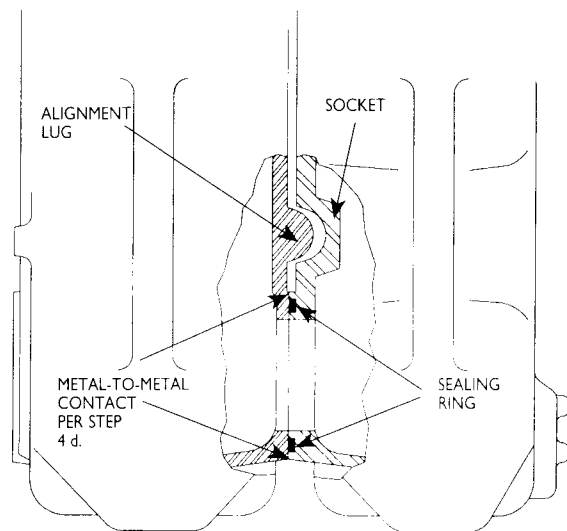

Figure 6

Install bottom refractory blanket on combustion chamber floor inside section block:

1. Unroll blanket only to depth of back section and first intermediate section.
2. Spread water glass on bottom side of blanket.
3. Press blanket into center bottom of sections.
4. Unroll and install blanket per steps 2 and 3 as each intermediate and front section are installed.
5. At front section, cut off blanket 2-1/2" from burner opening. Discard unused blanket.

Prepare remaining sections:

1. Follow "Prepare intermediate section" for remaining intermediate and front sections:
 - a. Remove any grit from threads inside tapped holes with clean rag.

WARNING

Do not use petroleum-based cleaning or sealing compounds in boiler system. Severe damage to system components can result, causing substantial property damage.

- b. Install TI (Tankless Intermediate) and SI (Supply Intermediate) sections (when used) in order shown in "Section Arrangement Table".
- c. Check each section for proper sealing rope position before proceeding to next section.

WARNING

Failure to position sealing rope properly can cause boiler to not seal gas-tight. Gas-tight seal prevents possible flue gas leakage and carbon monoxide emissions, resulting in severe personal injury or death.

- d. Make sure bottom refractory blanket has been installed per instructions on page 8.

SECTION ARRANGEMENT TABLE		
BOILER MODEL	MAXIMUM NO. OF HEATERS	SECTION ARRANGEMENT (all heaters must be on left side of boiler)
378 W&S	1	F - TI - B
478 W&S	1	F - TI - I - B
578 W&S	2	F - TI - I - TI - B
678 W&S	2	F - TI - I - TI - I - B
778 W&S	2	F - TI - I - TI - I - I - B
878 W&S	3	F - TI - I - TI - I - I - TI - B
978 W&S	3	F - TI - I - TI - I - TI - I - I - B
1078 W	3	F - TI - I - TI - I - I - TI - I - I - B
1078 S	3	F - TI - I - TI - SI - I - TI - I - I - B
1178 W	4	F - TI - I - TI - I - I - I - TI - I - TI - B
1178 S	4	F - TI - I - TI - I - SI - I - TI - I - TI - B
1278 W	4	F - TI - I - TI - I - I - I - TI - I - TI - B
1278 S	4	F - TI - I - TI - I - SI - I - I - TI - I - TI - B

W=Water, S=Steam; F=Front, TI=Tankless Intermediate, I=Intermediate, SI=Supply Intermediate for steam boilers, B=Back. "I" sections can be substituted for "TI" sections.

If you would like to pressure-test block assembly now, proceed to page 13.

Install burner mounting plate on front section:

1. Install four 1/2" x 4-3/4" studs to secure burner mounting plate to section:
 - a. Thread and lock together two nuts on rounded end of stud. Thread flat end of stud into one of four holes located around opening.
 - b. Remove nuts.
 - c. Repeat steps a and b for remaining studs.
2. Install burner mounting plate:
 - a. Apply 1/8" continuous bead of sealing rope adhesive in groove around opening in section.
 - b. Position 1/2" sealing rope in groove. Overlap ends at least one inch.
 - c. Install burner mounting plate. Use 1/2" washers and nuts.

Install observation port assemblies on front and back sections:

1. Install front observation port assembly:
 - a. Apply 1/8" continuous bead of sealing rope adhesive in groove on observation port.
 - b. Position 3/8" sealing rope in groove. Overlap ends at least one inch.
 - c. Secure assembly to section. Use 5/16-18 x 3/4" slotted head screws.
2. Repeat above steps for back observation port assembly.

If using TI sections:

Install tankless heaters and gaskets or heater cover plates and gaskets. Use 3/8" x 3/4" studs and nuts.

Install cleanout plates (see Figure 7):

WARNING

Cleanout plates must be installed gas-tight to prevent possibility of flue gas leakage and carbon monoxide emissions, resulting in severe personal injury or death.

1. Position two 1/4" x 1-3/4" carriage bolts in cleanout opening. Secure with washers and nuts.
2. Place blanket insulation piece against cleanout plate.
3. Mount cleanout plate over opening. Secure with nuts and washers.
4. Repeat steps 1 through 3 for remaining cleanout plates.

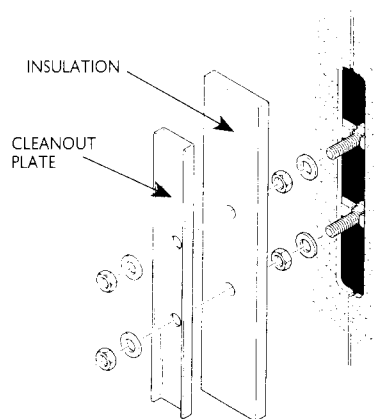

Cleanout Plate
Figure 7

Install flue collar assembly:

WARNING

Make sure gasket is intact, not torn or otherwise damaged. These conditions can cause possible flue gas leakage and carbon monoxide emissions, resulting in severe personal injury or death.

1. Place gasket on flue collar flanged surface:
 - a. Wipe all flanged surfaces with clean rag.
 - b. Apply rope adhesive to enough places on top, sides and bottom of flange to hold gasket in place.
 - c. Carefully lay gasket on flue collar flange, making sure to line up bolt holes on gasket and flange.

2. Mount collar on back section:

- a. Remove any grit from threads inside tapped holes with clean rag.
- b. Install one 5/16" x 1" flanged bolt halfway into bottom hole in section.
- c. Rest flue collar on flanged bolt, making sure to not damage gasket.
- d. Install 5/16" x 1" flanged bolts in lower two side holes.
- e. Tighten all 3 bolts.

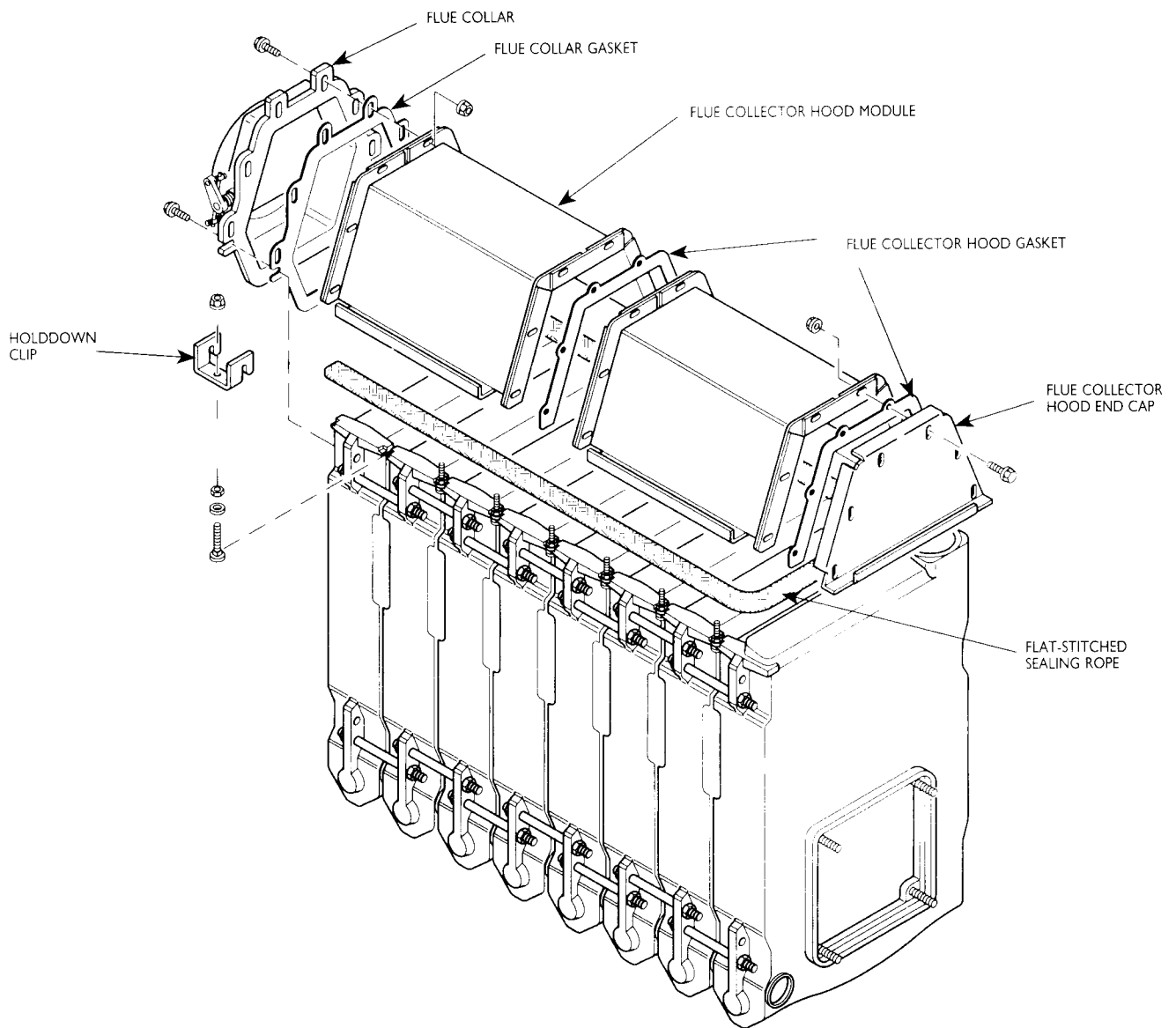

Flue Collar and Flue Collector Hood Assemblies
Figure 8

Prepare flue collector hood assembly:

WARNING

Make sure gaskets are intact, not torn or otherwise damaged. These conditions can cause possible flue gas leakage and carbon monoxide emissions, resulting in severe personal injury or death.

1. Stand one collector hood module on end.
2. Wipe all flanged surfaces with clean rag.
3. Lay gasket on flange. Refer to Figure 8.
4. Place end cap on gasket, aligning flanged surfaces. Secure with six 5/16" x 5/8" flanged bolts and flanged nuts. Tighten to 30 - 35 in.-lbs.
5. For 878 - 1278:
 - a. Stand remaining hood module on end.
 - b. Wipe all flanged surfaces with clean rag.
 - c. Lay gasket on flange.
 - d. Carefully place open end of first module on top of gasket, aligning flanged surfaces.
 - e. Secure with six 5/16" x 5/8" flanged bolts and flanged nuts.

6. Attach flat-stitched sealing rope to hood assembly. See Figure 9:
 - a. Lay hood on floor with flanged side up.
 - b. Wipe flanged surface with clean rag to remove dirt and oil.
 - c. Apply double-faced tape to flanged surface.
 - d. Apply rope to tape beginning on one side of open end of hood, leaving 1/4" extending past edge. Around corners, bend rope, do not cut. Do not stretch rope.

WARNING

Do not pre-cut rope. Gas-tight seal must be maintained to prevent possible flue gas leakage and carbon monoxide emissions, resulting in severe personal injury or death.

- e. Continue around entire flange. At other open end, leave 1/4" rope extending past edge. Cut off excess rope.

NOTICE

Double-faced tape serves only to hold sealing rope in place during installation. It will disintegrate over time. If collector hood and sealing rope is removed for any reason, new new tape and new gasket must be applied.

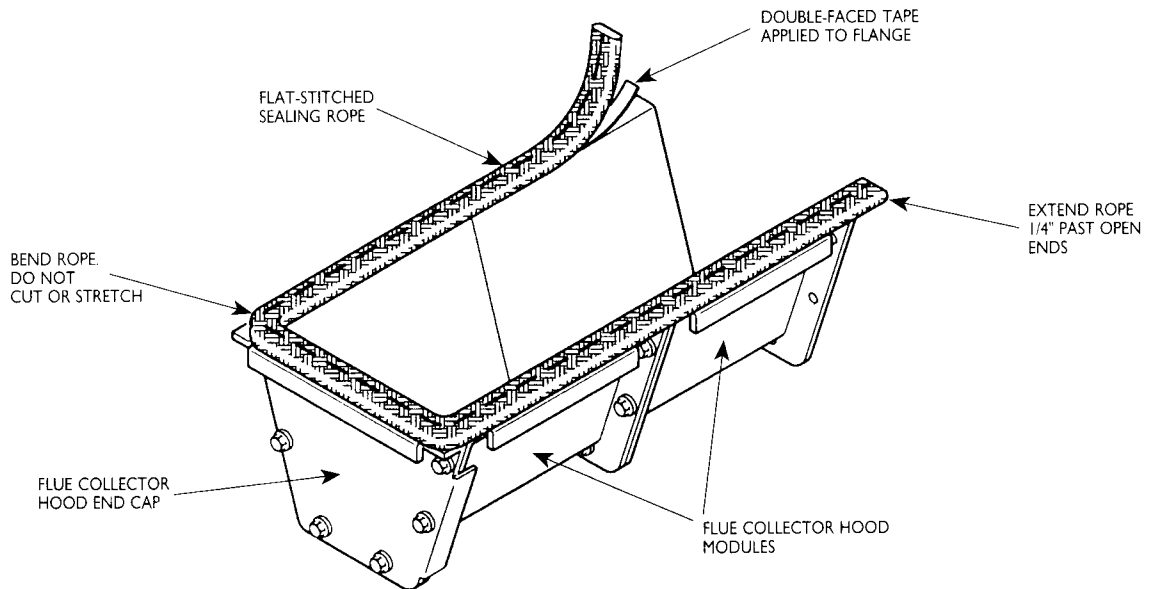

Sealing Rope Application on Collector Hood Assembly
Figure 9

Section C: Assemble Block

CONT'D

Install flue collector hood assembly:

1. Place hood on top of sections with open end of hood tightly against flue collar. Make sure flue collar gasket is in place, not broken, bent or folded.
2. Install 5/16" x 2" carriage bolts, flat washers and regular nuts on both sides of boiler starting at back section joint, continuing at each joint. See Figure 10. Tighten nuts.
3. Fasten hood to sections and flue collar:
 - a. Slide holddown clip over carriage bolt and flange on hood. Finger-tighten 5/16" flanged nut on carriage bolt. See Figure 10. Repeat for each clip. Where hood joint interferes with clip installation, do not install clip.
 - b. Install and finger-tighten six 5/16" x 1" flanged bolts and flanged nuts joining hood assembly to flue collar.
 - c. Center collector hood, making sure it is tight against flue collar. Evenly tighten nuts on holddown clips, being careful not to distort hood.

- d. Tighten six 5/16" x 1" flanged bolts and flanged nuts on flue collar to 30 - 35 in.-lbs.

WARNING

Overtightening bolts in flue collector hood assembly will cause gasket material to extrude, causing possible flue gas leakage and carbon monoxide emissions, resulting in severe personal injury or death.

4. Check gas-tight seal of flue collector hood and flue collar.

WARNING

Gas tight seal must be maintained to prevent possible flue gas leakage and carbon monoxide emissions, resulting in severe personal injury or death.

- a. Open damper in flue collar.
- b. Check inside section assembly for any light passing through unsealed areas.
- c. Mark all unsealed areas.
- d. At unsealed areas, check for damaged gaskets, sealing rope not in place, loose bolts or nuts, or missing holddown clips. Correct all conditions and repeat step b. If unsealed areas still exist, contact your Weil-McLain distributor or sales office before continuing installation.

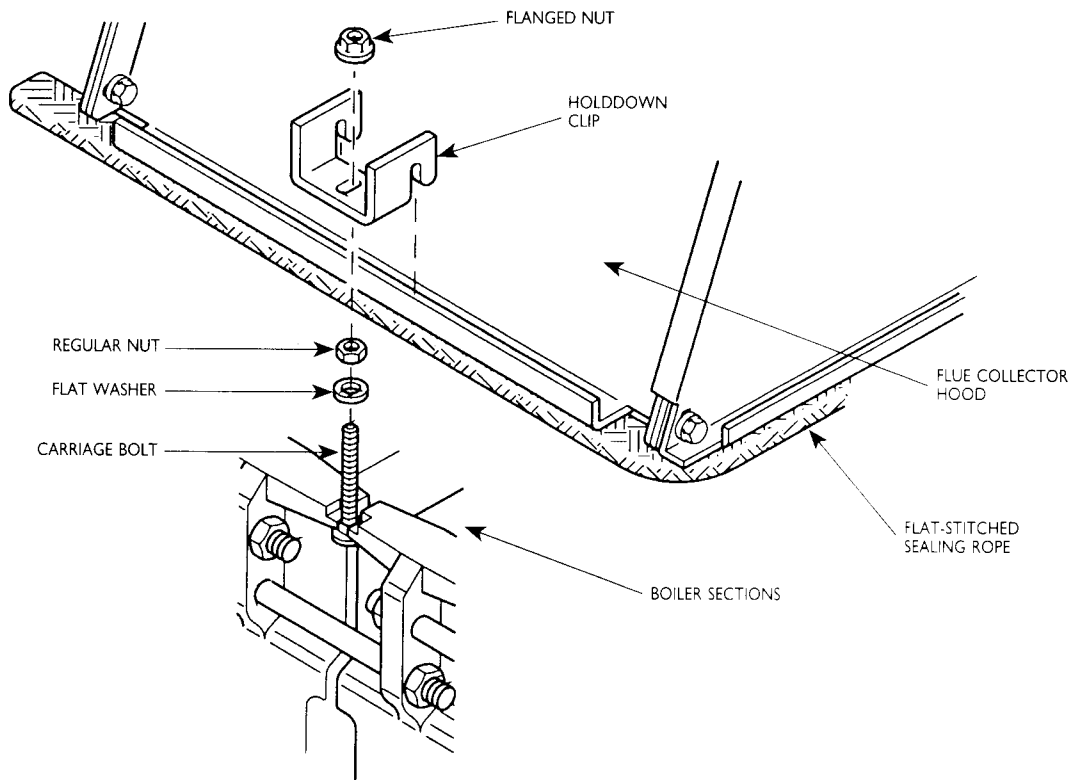

Holddown Clip Installation
Figure 10

Section D: Perform Hydrostatic Pressure Test

Prepare boiler:

1. Refer to Control Tapping Table and install:
 - a. Boiler drain (not furnished).
 - b. Water pressure gauge - for test only. Be sure gauge can handle test pressure - see step 1 under "Make test."
 - c. Air vent in upper tapping.
2. Plug remaining tappings.

CAUTION

Do not pressure test with any controls installed. Damage to control can occur.

Make test:

1. Fill boiler. Vent all air. For more than 10 minutes, pressure test:

Steam boilers between 45 - 55 psi.

Water boilers 1-1/2 times working pressure.

WARNING

Do not leave boiler unattended. Cold water fill could expand and cause excessive pressure, resulting in severe personal injury, death or substantial property damage.

2. Check for maintained gauge pressure and leaks. Repair if found.

WARNING

Leaks must be repaired at once. Failure to do so can damage boiler, resulting in substantial property damage.

WARNING

Do not use petroleum-based cleaning or sealing compounds in boiler system. Severe damage to system components can result, causing substantial property damage.

3. Drain boiler and remove air vent, boiler drain, gauge and plugs from tappings used for controls and accessories.

CONTROL TAPPING TABLE			
LOCATION	SIZE	STEAM	WATER
A	3"	Skim Tapping	Primary Probe-type Low Water Cutoff or Additional High Limit Control
B	3"	Steam Relief Valve	Water Relief Valve
C1	1"	--	Combination High/Low Limit Control
C1 & C2	1"	Primary Water Level Control (Float-type)	--
D1	1"	--	Alternate Probe-type Low Water Cutoff
D1 & D2	1"	Back-up Water Level Control (Float-type)	Float-type Low Water Cutoff
E1	1"	--	Firing Rate Control (When Used)
E1 & E2	1"	Gauge Glass	--
F1 & F2**	3/8"	Try Cock Tappings	--
G	1"	Limit Control, Operating Control, Pressure Gauge	Pressure-Temperature Gauge
H	1-1/2"	Boiler Drain	Boiler Drain
K	1"	--	Expansion Tank Piping or Automatic Air Vent
P***	1"	Back-up (ONLY) Probe-type Water Level Control (MM PS801-120 ONLY)	--

* 3" x 2" bushing and 2" plug provided with boiler.

** By special request only.

*** "P" tapping **not** intended for **primary** low water cutoff.

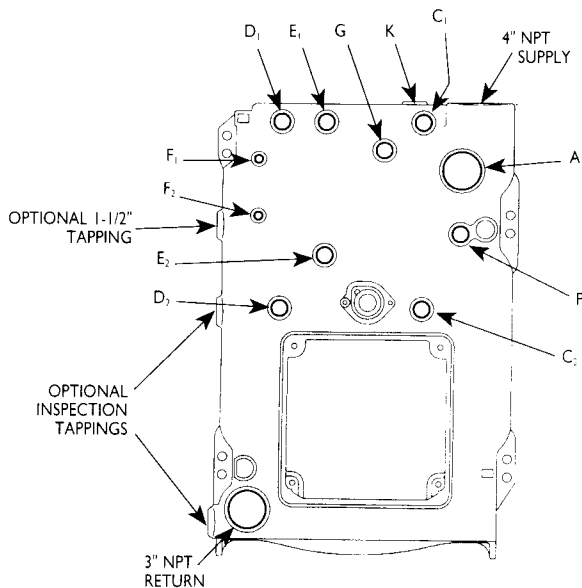

Front Section

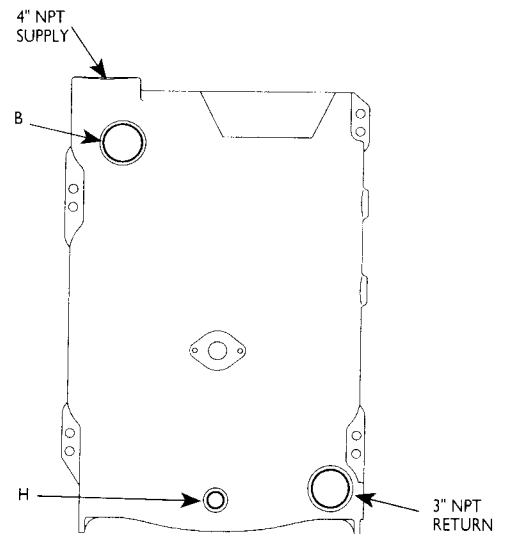

Back Section

Figure 11

Section E: Connect Water Boiler Piping

General water piping information:

- System water supply and return piping should be installed and piping connections attached to boiler before erecting jacket or installing controls.
- Do not pipe in through supply and out through return. This creates reverse water flow through boiler that must not be used.
- When three-way valves are used for temperature modulation, install slow-opening (minimum 10-minute) valves and boiler mixing pump to minimize potential of boiler thermal shock. See W-M Bulletin AE-8402.

Install piping:

Install piping as shown in Figure 12 below for single boilers. Page 15 for multiple boilers.

CAUTION

Improperly piped systems or undersized piping can contribute to erratic boiler operation and possible boiler or system damage.

1. Connect supply and return piping:

a. Size according to tables below.

- 1) For **unknown flow rates**, size piping per Table below, using 20°F. temperature rise through boiler.

RECOMMENDED MINIMUM PIPE SIZES FOR UNKNOWN FLOW RATES*		
BOILER MODEL	SUPPLY PIPE SIZE A	RETURN PIPE SIZE B
378	2"	2"
478	2-1/2"	2-1/2"
578-678	3"	3"
778-1278	4"	4"

* All piping sizes based on 20°F. temperature rise through boiler.

- 2) For **known flow rates or higher flow rate** through boiler, size piping per Table below.

WARNING

Flow at higher velocities than shown in Table below for pipe size can damage boiler, causing substantial property damage.

RECOMMENDED MINIMUM PIPE SIZES FOR KNOWN FLOW RATES		
WATER FLOW RATE GPM	SUPPLY PIPE SIZE A	RETURN PIPE SIZE B
Up to 35	2"	2"
36 to 50	2-1/2"	2-1/2"
51 to 77	3"	3"
78 to 142	4"	4"

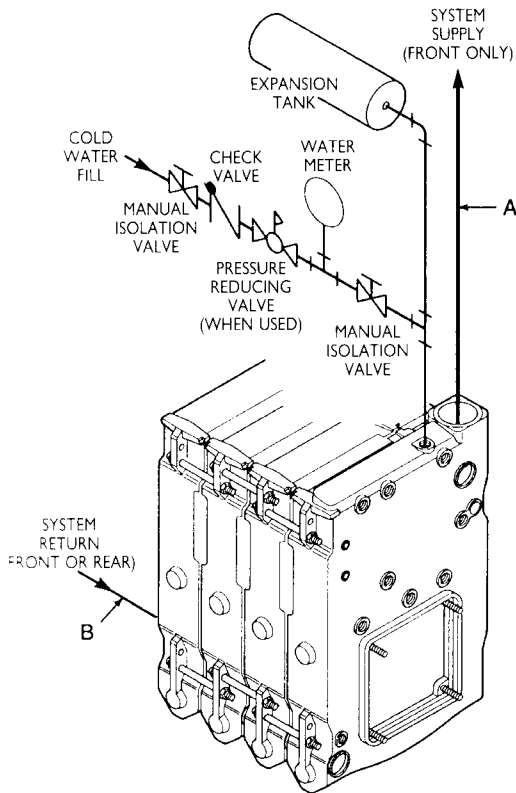

Water Boiler Piping
Figure 12

- Locate circulator in supply piping.
- For return piping, use full diameter pipe for 10 times that diameter before making any reduction. For example, a 4-inch return should not be reduced any closer to boiler return tapping than 40 inches.
- Install system blow-off (drain) valve in lowest part of return piping close to boiler. ASME Size requirements are shown in Table below.

ASME DRAIN VALVE SIZE	
BOILER MODEL	VALVE SIZE (IN.)
378 - 478	3/4
578 - 1178	1
1278	1-1/4

Section E: Connect Water Boiler Piping

CONT'D

2. Install expansion tank:
 - a. Closed type - connect to 1" tapping "K" (refer to Control Tapping Table, page 13). Use 1" N.P.T. piping. Any horizontal piping must pitch up toward tank at least 1 inch per each 5 feet of piping.
 - b. Diaphragm type - Refer to tank manufacturer's literature for location. Install automatic air vent in "K" tapping.
 - c. Connect cold water fill to expansion tank piping. See Figure 12. Also shown are recommended valves and water meter, when used. Water meter will detect added make-up water, indicating leaks in system.

3. Piping for multiple boilers (see Figure 13):

- (A)** Size secondary boiler pump GPM based on following formulas:

$$\frac{\text{GROSS OUTPUT IN BTUH}}{\text{TEMPERATURE RISE IN } ^\circ\text{F} \times 500} = \text{GPM}$$

NOTE: TEMPERATURE RISE IN } ^\circ\text{F} = 230^\circ\text{F} - \text{RETURN WATER TEMPERATURE}

Calculate only secondary piping circuit resistance. Boiler resistance will be about equal to three 90-degree elbows of secondary pipe size. Operate each boiler and its secondary pump from EMCS system. **Do not** maintain boiler at predetermined water temperature.

- (B)** Primary pump GPM and head calculation should not include secondary boiler circuits. Primary pump can operate continuously during heating season.
- (C)** Space 12" maximum or as close as practical.
- (D)** Check valve.
- (E)** Hand valve.

Expansion tank(s), relief valves and other accessories are required but not shown.

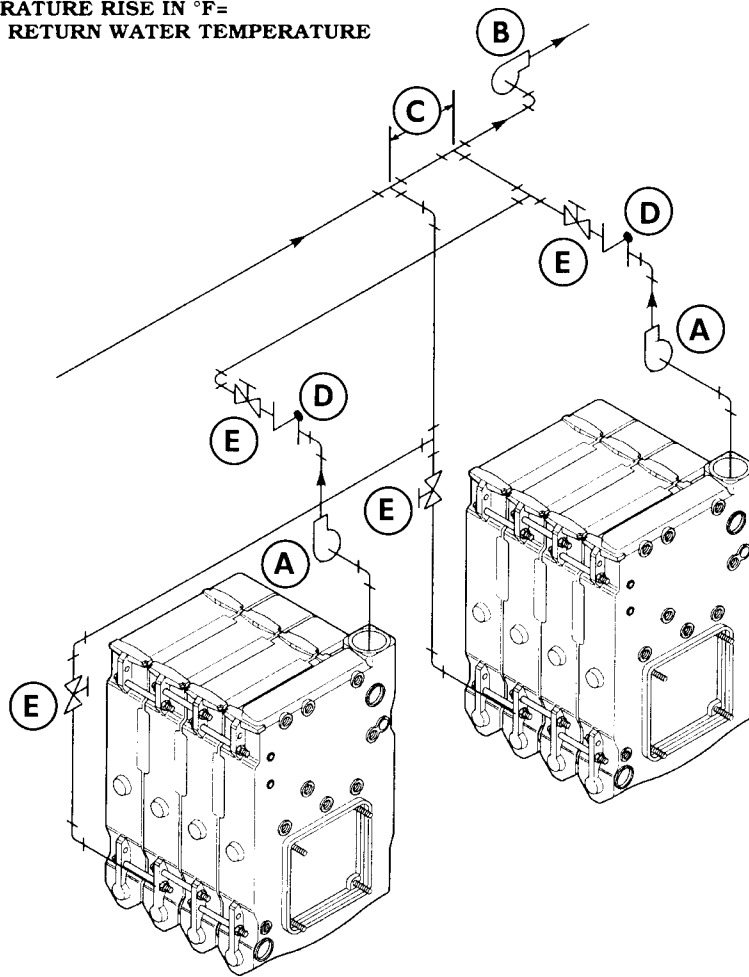

Multiple Water Boiler Piping
Figure 13

Section F: Connect Steam Boiler Piping

General steam piping information:

- Hartford Loop piping arrangement and wet return are required for steam boilers.
- Maintain 24-inch minimum from waterline to bottom of header (56-1/4" from bottom of section).
- When using condensate receiver, feed pump must be energized by boiler-mounted pump controller.

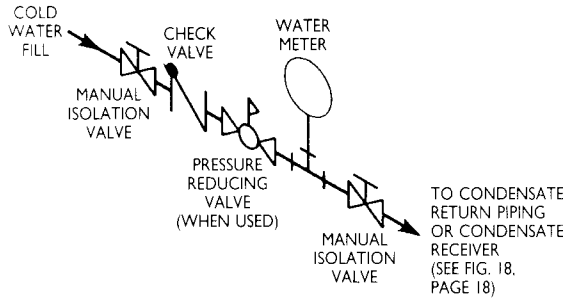

Cold Water Fill Piping
Figure 14

Install piping:

Install piping as shown on page 17 for single boilers, page 19 for multiple boilers.

CAUTION

Improperly piped systems or undersized piping can contribute to erratic boiler operation and possible boiler or system damage. Piping system must be installed as shown, using pipe sizes shown. Consult local Weil-McLain distributor or sales office before installing alternate piping.

1. Connect supply and return piping:
 - a. See table below and:
 - 1) Size forced condensate return piping by pump.
 - 2) Size gravity condensate return same as equalizer "J" pipe size.
 - b. Install system drain valve in lowest part of return piping close to boiler. ASME size requirements are shown in Table, page 14.
 - c. Connect cold water fill piping as shown in Figure 14. Also shown are recommended valves and water meter, if used. Water meter will detect added make-up water, indicating leaks in system.

STEAM BOILER PIPE SIZE TABLE BASED ON 2-PIPE STEAM SYSTEM						
FIG. NO.	BOILER MODEL	*RISER PIPE SIZE - IN.			** H HEADER IN.	J EQUALIZER IN.
		A	B	C		
15	378	3			3	2
15	478	4			4	2
15	578	4			4	2-1/2
16	678	3	3		4	2-1/2
16	778	4	4		4	2-1/2
16	878	4	4		4	3
16	978	4	4		6	3
17	1078-1278	4	4	4	6	3

* Based on ASHRAE Handbook recommendations, allowing 1/2 oz. pressure drop per 100 feet of pipe for dry return.

** Based on ASHRAE Handbook recommendations, allowing 2 oz. pressure drop per 100 feet of pipe at 3.5 PSIG. Maintain minimum 24" height from waterline to header

Section F: Connect Steam Boiler Piping

CONT'D

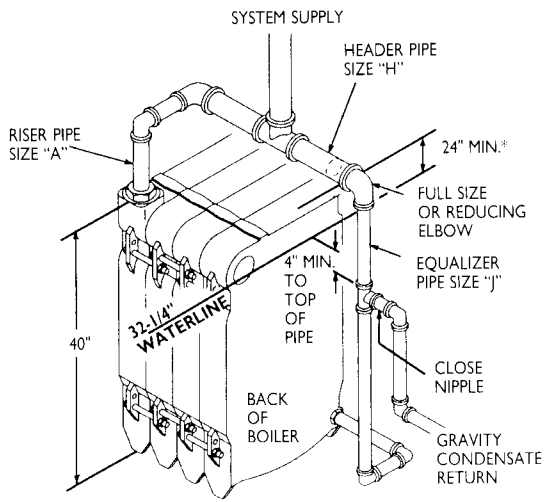

***24" minimum from water line to bottom of header**
378 through 578
Steam Boiler Piping
Figure 15

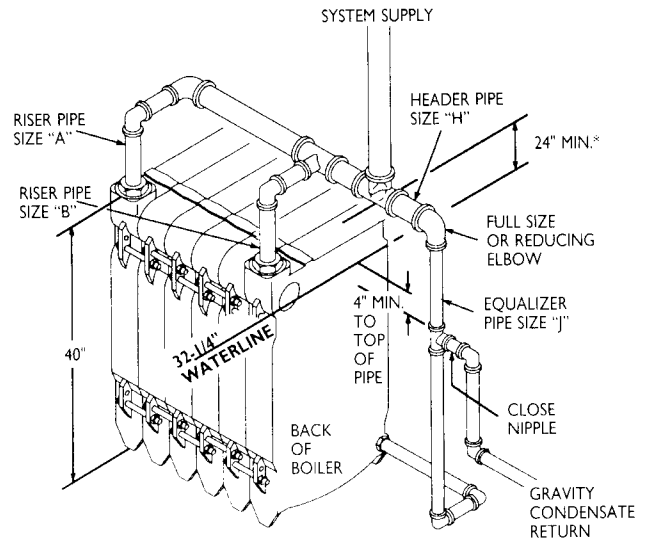

***24" minimum from water line to bottom of header**
678 through 978
Steam Boiler Piping
Figure 16

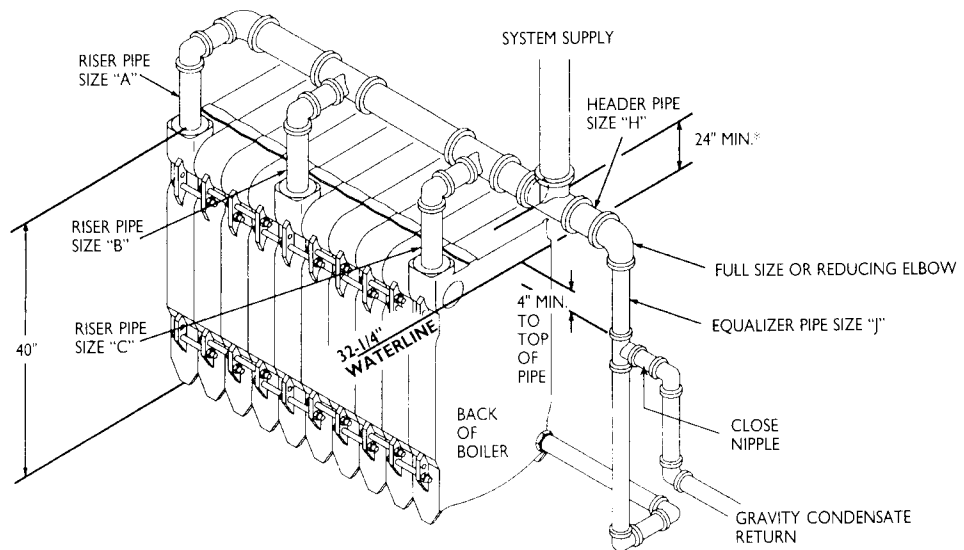

***24" minimum from water line to bottom of header**
1078 through 1278
Steam Boiler Piping
Figure 17

Section F: Connect Steam Boiler Piping

CONT'D

2. Condensate piping:

Satisfactory operation of any steam heating system depends on adequate return of condensate to maintain steady water level. Avoid adding excessive amounts of raw make-up water. Where condensate return is not adequate, a low water cutoff with pump control, condensate receiver, and condensate boiler feed pump should be installed. Refer to Figure 18 for piping and to Condensate Receiver Capacity Table for sizing.

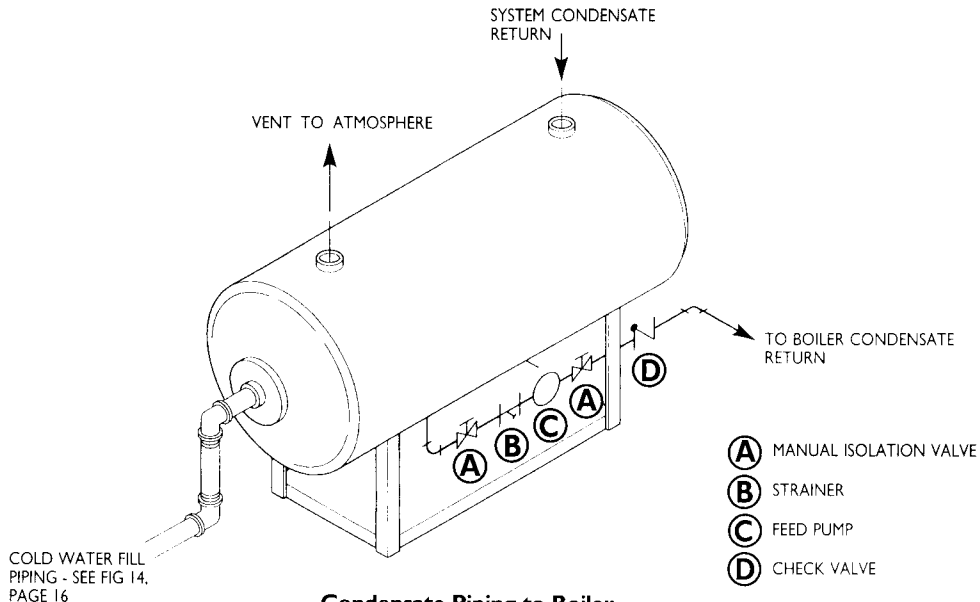

Condensate Piping to Boiler
Figure 18

CONDENSATE RECEIVER CAPACITY TABLE							
BOILER MODEL	I=B=R GROSS OUTPUT LBS. STEAM PER HOUR	GALLONS CONDENSATE PER HOUR	MINIMUM CONDENSATE RECEIVER CAPACITY - GAL.				RECOMMENDED CONDENSATE FEED PUMP CAPACITY GPM AT 15 PSI
			15 MIN. * BOILER OPERATION	30 MIN. * BOILER OPERATION	45 MIN. * BOILER OPERATION	60 MIN. * BOILER OPERATION	
378	278	34	11	21	31	41	1.1
478	400	48	15	29	44	58	1.6
578	521	63	19	38	57	76	2.1
678	643	77	24	47	70	93	2.6
778	764	92	28	56	83	111	3.1
878	886	106	32	64	95	127	3.5
978	1007	121	37	73	109	145	4.0
1078	1129	136	41	82	122	163	4.5
1178	1250	150	45	90	135	180	4.8
1278	1372	165	50	99	149	198	5.4

* Maximum time to when condensate returns to boiler.

Section F: Connect Steam Boiler Piping

CONT'D

3. Multiple steam boiler piping with gravity condensate return:

(A) Install boiler feed pump or solenoid control on each boiler with body mark at level indicated on page 23. Use:

- Separate feed pumps and check valves for each boiler, or ...
- Single feed pump and separate solenoid valves for each boiler.

(B) Install combination float and thermostatic trap on each boiler to prevent flooding of one boiler while other boiler is firing. For 78 boiler, install trap in skim tapping (see page 22). Connect traps to condensate receiver.

(C) Install boiler piping as shown in boiler manual.

(D) Install stop valves per ASME code requirements and slow-opening automatic steam valves when used. Use EMCS system to open automatic steam valve before firing burner.

(E) Construct common supply drop header with pipe size at least same size as largest boiler header size.

(F) Use:

- EMCS system with header-mounted pressure control(s) to sequence boilers. OR
- Steam pressure controller.

(G) Install drain line in common supply drop header. Use combination float and thermostatic trap and drain to condensate receiver.

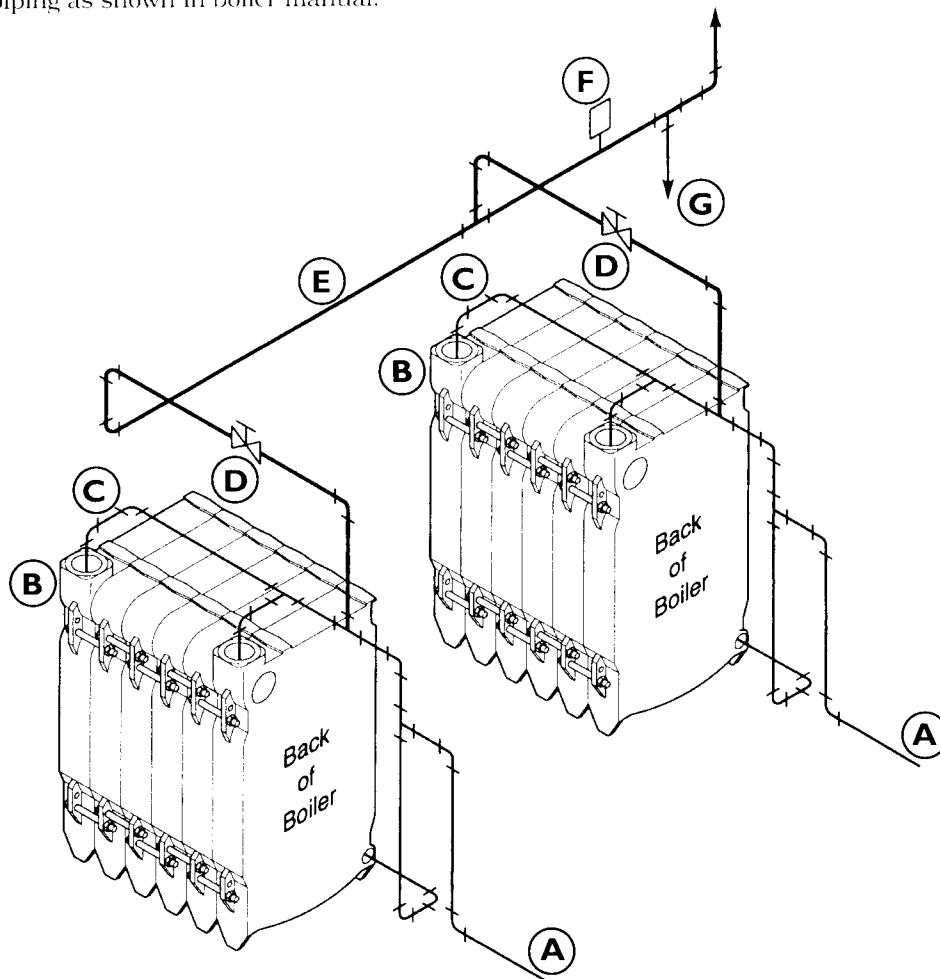

Multiple Steam Boiler Piping
Gravity Condensate Return
Figure 19

Section G: Install Jacket

Install Jacket:

1. Packaged boilers - install top jacket panel.
2. Non-packaged boilers - refer to instructions packed in jacket carton. The following must be complete before jacket is installed:
 - boiler hydrostatically pressure-tested. See page 13.
 - plugs for unused tapings installed. See Control Tapping Table, page 13.
- supply and return piping installed. See pages 14 through 19.
- cleanout plates, flue collar and flue collector hood installed. See pages 9 - 12.

Section H: Pipe Tankless Heaters

To pipe tankless heaters:

1. Size piping no smaller than heater inlet and outlet.
2. Automatic mixing valve must be installed. See Figure 20. Follow manufacturer's instructions to install.
3. Flow regulating valve must be installed. Size according to continuous draw of heater. See Table below. Follow manufacturer's instructions to install.
4. Operating control with small adjustable differential scale is recommended. Install in temperature control tapping in heater plate.
5. Multiple tankless heaters (see Figure 20):
 - a. Use cold water supply header with individual risers to each heater. Size header by increasing one pipe size for each additional heater.
 - b. Use hot water outlet header with individual risers to each heater. Size header by increasing one pipe size for each additional heater.
 - c. Do not pipe multiple heaters in series.
6. In hard water areas, soften cold domestic supply water to heaters to prevent lime build-up.

TANKLESS HEATER RATINGS TABLE *		
TANKLESS HEATER MODEL	** CONTINUOUS DRAW GPM	INLET AND OUTLET TAPPINGS
78-24	6.5	3/4"

* GPM heated from 40°F to 140°F (100°F temperature rise) with 200°F boiler water temperature.

** Continuous draw - no recovery period.

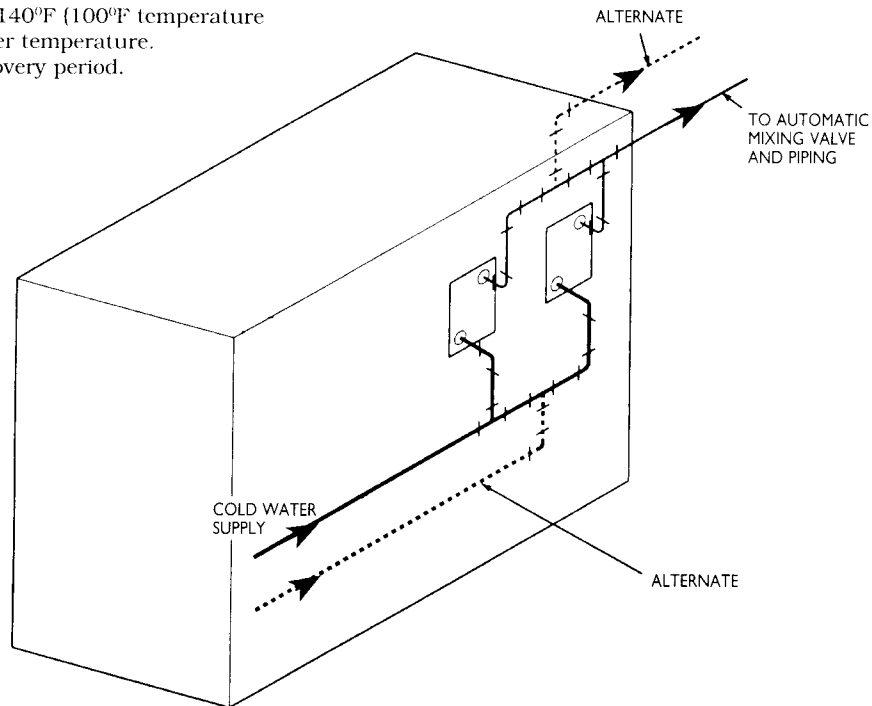

Tankless Heater Piping
Figure 20

Section I: Install Water Boiler Controls

Install controls:

1. Install furnished controls where shown in Control Tapping Table and Figure 21.

WARNING

Failure to properly install, pipe and wire boiler controls can result in severe damage to boiler, building and personnel; and is not covered by boiler warranty.

2. Relief valve must be installed with spindle in vertical position. Use fittings provided with boiler. Do not make any other connection in that piping.

WARNING

Relief valve discharge line must be piped near floor close to drain to eliminate potential of severe burns. Do not pipe to any area where freezing could occur. Do not plug, valve or place any obstruction in discharge line.

3. When installing low water cutoff:
 - a. Must be installed if boiler is located above radiation level.
 - b. May be required on water boilers by certain state, local or territorial codes or insurance companies.
 - c. Install low water cutoff designed for water installations where shown in Control Tapping Table and Figure 21.
4. If installation is to comply with ASME installation requirements, an additional high temperature limit is needed. Purchase and install in supply line between boiler and isolation valve or in tapping "A."

5. Dual limit control settings:
 - Low - set according to design requirements.
 - High - at least 20° higher than low limit, 240°F, maximum.
6. Install optional controls per control manufacturer's instructions.

WATER CONTROL TAPPING TABLE		
LOCATION	SIZE	FUNCTION
A	3"	Primary Probe-type Low Water Cutoff or Additional High Limit Control
B	3"	Water Relief Valve
C1	1"	Combination High/Low Limit Control
D1	1"	Alternate Probe-type Low Water Cutoff
D1 & D2	1"	Float-type Low Water Cutoff
E1	1"	Firing Rate Control (When Used)
G	1"	Pressure-Temperature Gauge
H	1-1/2"	Boiler Drain
K	1"	Expansion Tank Piping or Automatic Air Vent

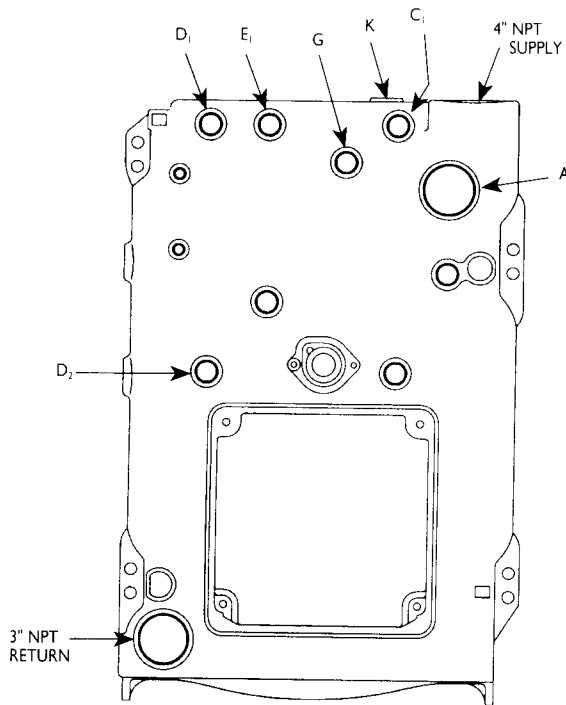

Front Section

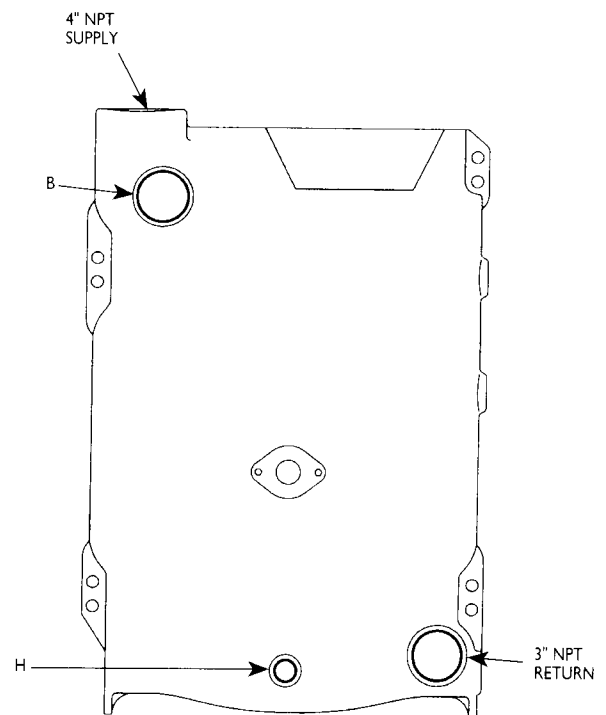

Back Section

Water Control Location
Figure 21

Section J: Install Steam Boiler Controls

Install controls:

1. Install controls where shown in Control Tapping Table and Figure 22.

WARNING

Failure to properly install, pipe and wire boiler controls can result in severe damage to boiler, building and personnel; and is not covered by boiler warranty.

- a. Install steam pressure operating and high limit controls and pressure gauge. See Figure 23. Pressure limit control settings:
 - Low - set according to design requirements.
 - High - set at least 2 psi higher than low limit, 15 psi maximum.
- b. Relief valve must be installed with spindle in vertical position. Use fittings provided with boiler. Do not make any other connection in that piping.

WARNING

Pipe relief valve discharge through vertical piping to atmosphere. Install drain pan elbow to drain condensate. Pipe near floor close to floor drain to eliminate potential of severe burns. Do not pipe to any area where freezing could occur. Do not plug, valve or place any obstruction in discharge line.

- c. Install water level controls and gauge glass as shown in Figure 24.
 - 1) Fittings for controls to be furnished by others.

- 2) If water level control is not shown in Figure 24, locate cast-on-body mark on control and install per manufacturer's instructions.

NOTICE

Do not use water level controls with quick hook-up fittings. Nuisance shutdowns will occur.

STEAM CONTROL TAPPING TABLE		
LOCATION	SIZE	FUNCTION
A	*3"	Skim Tapping
B	3"	Steam Relief Valve
C1 & C2	1"	Primary Water Level Control (Float-type)
D1 & D2	1"	Back-up Water Level Control (Float-type)
E1 & E2	1"	Gauge Glass
F1 & F2**	3/8"	Try Cock Tappings
G	1"	Limit Control, Operating Control, Pressure Gauge
H	1-1/2"	Boiler Drain
P***	1"	Back-up (ONLY) Probe-Type Water Level Control (MM PS801-120 ONLY)

- * 3" x 2" bushing and 2" plug provided with boiler.
- ** By special request only.
- *** "P" tapping **not** intended for **primary** low water cutoff.

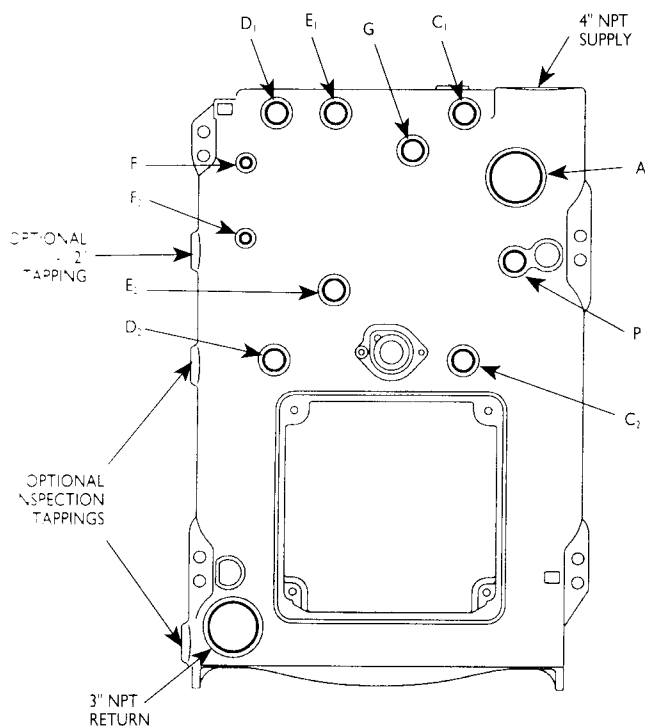

Front Section

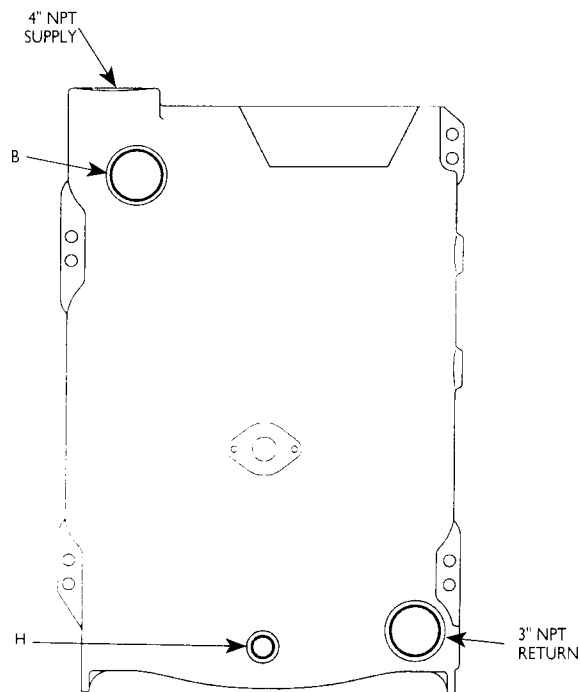

Back Section

Steam Control Location
Figure 22

Section J: Install Steam Boiler Controls

CONT'D

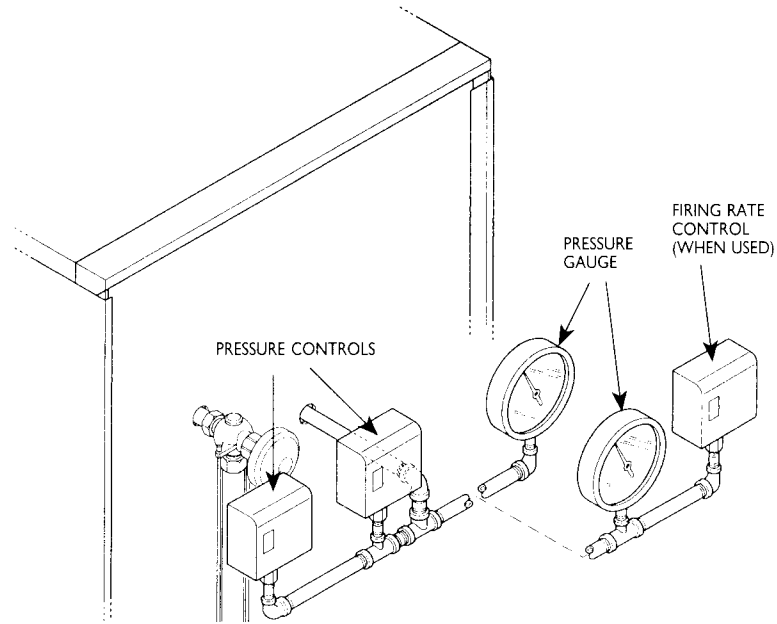

Steam Control Siphon and Fittings
Figure 23

WATER LEVEL CONTROL LOCATION TABLE				
PRIMARY WATER LEVEL CONTROL*	CASTING LINE HEIGHT ABOVE BOTTOM OF GAUGE GLASS (A)	BACK-UP WATER LEVEL CONTROL*	CASTING LINE HEIGHT ABOVE BOTTOM OF GAUGE GLASS (B)	BACK-UP (ONLY) PROBE-TYPE WATER LEVEL CONTROL IN "P" TAPPING
61, 63	1-1/2"	61, 63	1/2"	MM PS801-120
42, 150MD, 157MD ** #	2-3/8"	61, 63	1/2"	MM PS801-120
93, 193 ** #	1-3/4"	61, 63	1/2"	MM PS801-120
51-2, 51-S-2 **	2-5/8"	61, 63	1/2"	MM PS801-120

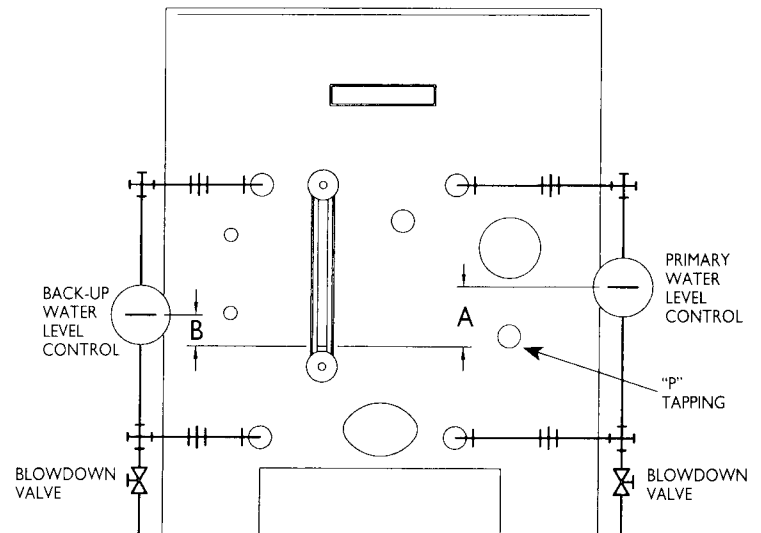

- * Other manufacturer's controls providing similar function may be used, if properly located and selected.
- ** Cannot be used as backup water level controls.
- # When pump control is used with feed water tank, install pump control on boiler and make-up water feeder on tank. Use separate low water cut off on boiler when back-up is needed. Do not install combination low water cut-off and feeder as back-up control on boiler. Feeder will operate before pump control operates.

Water Level Control Location
Figure 24

Section K: Connect Breeching and Venting Systems

General venting information:

- 78 boilers operate with overfire positive pressure. Adjust breeching damper in flue collar (see page 26) during burner start-up to achieve 0.1" W.C. positive pressure at flue collar.

Select type of venting system:

- **Forced draft -**
Boiler, breeching and stub vent operate at positive pressure. Entire system must be gas-tight to prevent leaks. Stub vent height must be limited to prevent negative draft with 3-foot minimum stub vent height above roof. See Figures 25 and 26.
- **Balanced draft -**
Boiler operates with positive pressure overfire. Chimney **may** provide excess draft which may require a barometric draft control installed and set to provide minimum draft to maintain 0.1" positive pressure at flue collar. Minimum chimney height above roof is 3 feet. See Figures 27 and 28.

Construct metal breeching:

- See back cover for minimum breeching diameter.
- Select material type and thickness in compliance with local codes.

WARNING

Conventional flue pipe should not be used as it could leak flue gases and carbon monoxide emissions through seams and joints, resulting in severe personal injury or death.

- Refer to ASHRAE Guide for chimney and breeching calculations and construction and lining.

WARNING

Long horizontal breechings, excessive number of tees and elbows or other obstructions restricting combustion gas flow can result in possibility of condensation, flue gas leakage and carbon monoxide emissions, causing severe personal injury or death.

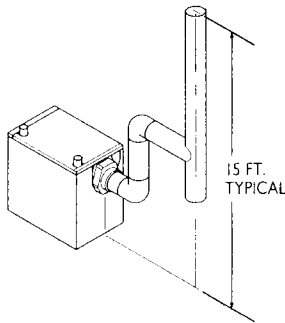

**Stub Vent - Forced Draft
Single Boiler
Figure 25**

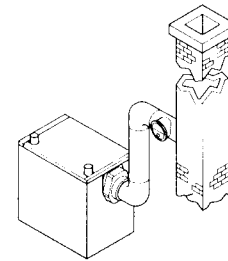

**Conventional Chimney - Balanced Draft
Barometric Draft Control When Required
Single Boiler
Figure 27**

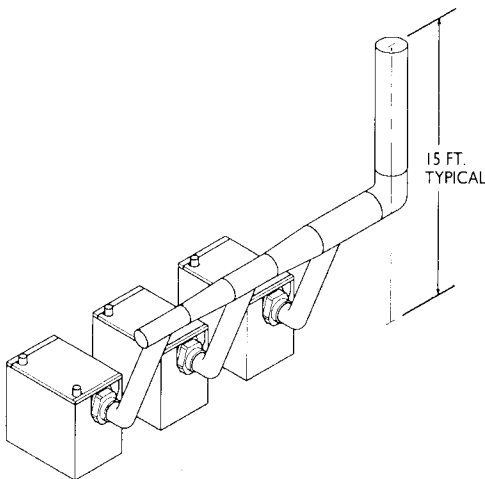

**Stub Vent - Forced Draft
Multiple Boiler
Figure 26**

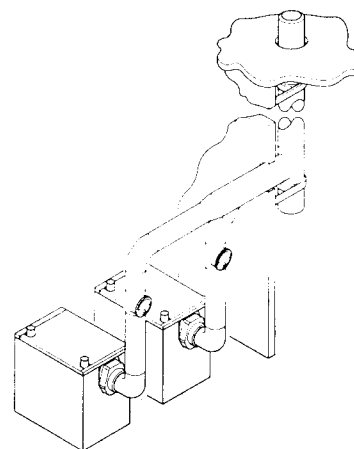

**Conventional Chimney - Balanced Draft
Barometric Draft Control When Required
Multiple Boiler
Figure 28**

Section L: Install Burner

To install burner:

1. Unpack burner.
2. Place gasket around air tube and against burner mounting flange. If sealing rope is used, apply 1/8" continuous bead of rope adhesive around burner mounting flange and apply sealing rope to make gas-tight seal.
3. Mount burner into opening in burner mounting plate.
CAUTION Maintain gas-tight seal between burner mounting flange and plate to prevent damage to air tube.
4. Level burner using burner support brackets where required.
5. Secure with furnished bolts.
6. Retain burner information packet. Keep with boiler.

Section M: Wiring and Fuel Piping

WARNING

Electric shock hazard. Can cause severe personal injury or death if power source is not disconnected before installing or servicing boiler and burner.

To wire burner and boiler controls:

1. Install all wiring in compliance with:
 - National Electrical Code ANSI/NFPA 70.
 - Any additional national, state, or local codes.
2. Follow burner manual and wiring diagram found in burner information packet.
3. Use 14 ga. wire for operating and safety circuit wiring.
4. Where burner motor voltage differs from control voltage, supply proper voltage to each. Size fused disconnect(s) and conductors per National Electrical Code ANSI/NFPA 70.

To install gas and/or oil piping:

1. Install all piping in compliance with:
 - Local, state or national codes and regulations.
 - Separate burner manual provided with burner.
2. Use pipe joint compound (pipe dope) resistant to corrosive action of fuel oil or liquified petroleum gases. Apply sparingly to male threads of pipe joints. Do not use any kind of pipe tape.
3. Oil piping - use flare-type fittings, not compression-type.

DANGER

Do not use compression or soldered fittings. No safe repair can be made. Severe personal injury, death or substantial property damage will result.

Section N: Make Final Adjustments

To fill water boilers:

1. Close manual air vents and drain cocks.
2. Fill to correct system pressure. Correct pressure will vary with each installation.
3. Starting on lowest floor, open air vents one at a time until water squirts out. Close vent. Repeat with remaining vents.
4. Refill boiler to correct pressure.

To fill steam boilers:

1. Do not fill (except for leakage test) until boiler is ready to be fired.
2. Fill to normal waterline, halfway up gauge glass.
3. Recommend boiler water pH 7.0 to 8.5.

Adjust burner and breeching damper:

WARNING

Make final burner adjustments using combustion test equipment to assure proper operation. Do not fire boiler without water. Sections will overheat, damaging boiler and resulting in severe property damage.

1. Lock open breeching damper.
2. Refer to burner manual for start-up and service.
3. Let burner advance to high fire. Heat boiler to design conditions.
4. Using combustion test equipment, adjust burner for:
 - a. 12% ($\pm 1/4\%$) CO_2 for No. 2 fuel oil, 0 smoke.
 - b. 9 - 10% CO_2 natural gas, CO in flue gas to not exceed 100 ppm (0.01%).
5. Adjust breeching damper to assure 0.1" W.C. positive pressure at test opening. Secure damper.
6. Adjust barometric draft control, when used, to design conditions.
7. Check per steps 4 through 6. Adjust as required.
8. Plug test opening with 1/8" brass plug.

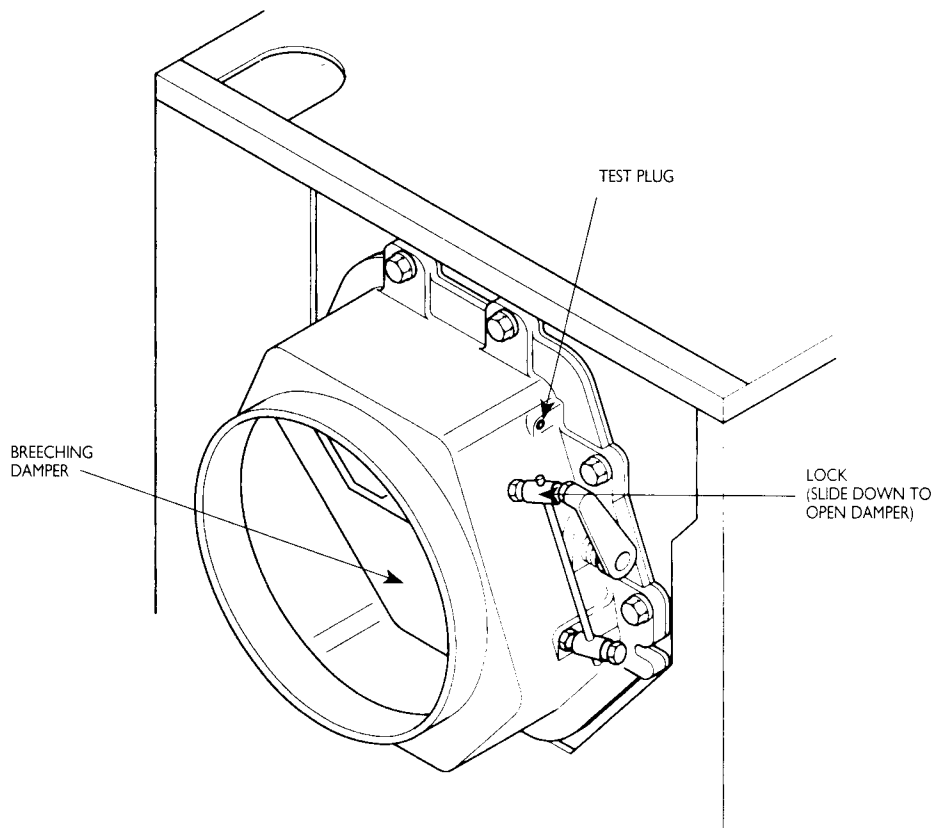

Breeching Damper Adjustment
Figure 29

Section N: Make Final Adjustments

Skim steam boilers:

NOTICE

Clean all newly install steam boilers to remove oil. Failure to properly clean can result in violent water level fluctuations, water passing into steam mains, or high maintenance costs on strainers, traps and vents. Skim boiler only. Do not clean old piping or leaks can occur.

WARNING

Do not use petroleum-based cleaning or sealing compounds in boiler system. Severe damage to system components can result, causing substantial property damage.

1. Remove 2" plug from 3" x 2" bushing at skim tapping. Provide 2" skim piping from tapping to floor drain.
2. Raise waterline to midpoint of skim piping.
3. Fire burner to maintain temperature below steaming rate during skimming process.
4. Feed in water to maintain water level. Cycle burner to prevent rise in steam pressure.
5. Continue skimming until discharge is clear. This may take several hours.
6. Drain boiler. While boiler is warm **but not hot**, flush all interior surfaces under full pressure until drain water runs clear.
7. Remove skim piping. Re-insert plug at boiler skim tapping.
8. Close drain cock. Fill with fresh water to normal waterline. Start burner and steam for 15 minutes to remove dissolved gases. Stop burner.
9. Check traps and air vents for proper operation.

Determine if water treatment is needed (water boilers only):

WARNING

Do not use petroleum-based cleaning or sealing compounds in boiler system. Severe damage to system components can result, causing substantial property damage.

Continual make-up water will reduce boiler life. Minerals can build up in sections, reducing heat transfer, overheating cast iron and causing section failure.

For unusually hard water areas or low pH conditions (less than 7.0) consult local water treatment company.

Freeze protection (when used):

1. Use antifreeze especially made for hydronic systems. Inhibited propylene glycol is recommended.
WARNING Do not use automotive, ethylene glycol or undiluted antifreeze. Severe personal injury or death can result.
2. 50% solution provides protection to about -30°F.
3. Local codes may require back-flow preventer or actual disconnect from city water supply.
4. Determine quantity according to system water content. Boiler water content is listed on page 30. Percent of solution will affect sizing of heat distribution units, circulator and expansion tank.
5. Follow antifreeze manufacturer's instructions.

Check boiler for gas-tight seal:

WARNING

Boiler must be sealed gas-tight to prevent possible flue gas leakage and carbon monoxide emissions, resulting in severe personal injury or death.

1. Remove boiler jacket side and top panels.
2. Start burner. Observe all sealing points and chalk-mark any not gas-tight.
3. To seal all chalk-marked areas:
 - a. use silicone sealant on section flueways.
 - b. check gaskets and sealing rope placement.
4. Reinstall all jacket panels.

Section O: Data and Dimensions

BOILER MODEL	DATA				DIMENSIONS						
	SUPPLY TAPPINGS - QUANTITY AND SIZE*		RETURN TAPPINGS - QUANTITY AND SIZE*		A	B	D	E	H	W	L
	WATER	STEAM	WATER	STEAM							
378	2 - 4"	2 - 4"	2 - 3"	2 - 3"	13-1/8	--	8	42-1/2	13-1/2	20-3/8	21-1/2
478	2 - 4"	2 - 4"	2 - 3"	2 - 3"	20-1/8	--	8	42-1/2	20-1/2	27-3/8	28-1/2
578	2 - 4"	2 - 4"	2 - 3"	2 - 3"	27-1/8	--	8	42-1/2	27-1/2	34-3/8	35-1/2
678	2 - 4"	2 - 4"	2 - 3"	2 - 3"	34-1/8	--	8	42-1/2	34-1/2	41-3/8	42-1/2
778	2 - 4"	2 - 4"	2 - 3"	2 - 3"	41-1/8	--	10	41-1/2	41-1/2	48-3/8	49-1/2
878	2 - 4"	2 - 4"	2 - 3"	2 - 3"	48-1/8	--	10	41-1/2	48-1/2	55-3/8	56-1/2
978	2 - 4"	2 - 4"	2 - 3"	2 - 3"	55-1/8	--	10	41-1/2	55-1/2	62-3/8	63-1/2
1078	2 - 4"	3 - 4"	2 - 3"	2 - 3"	62-1/8	27-1/8	10	41-1/2	62-1/2	69-3/8	70-1/2
1178	2 - 4"	3 - 4"	2 - 3"	2 - 3"	69-1/8	34-1/8	10	41-1/2	69-1/2	76-3/8	77-1/2
1278	2 - 4"	3 - 4"	2 - 3"	2 - 3"	76-1/8	41-1/8	12	40-1/2	76-1/2	83-3/8	84-1/2

* Use piping connections shown in manual, pages 14 - 19.

Section O: Data and Dimensions

CONT'D

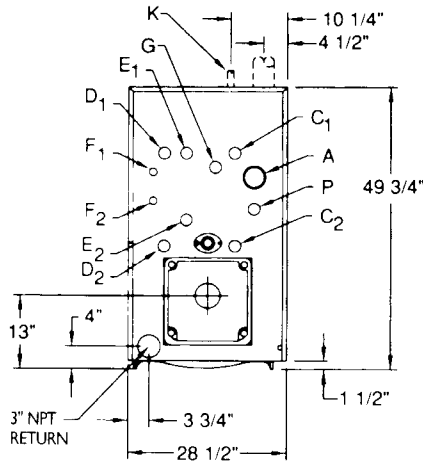

Front

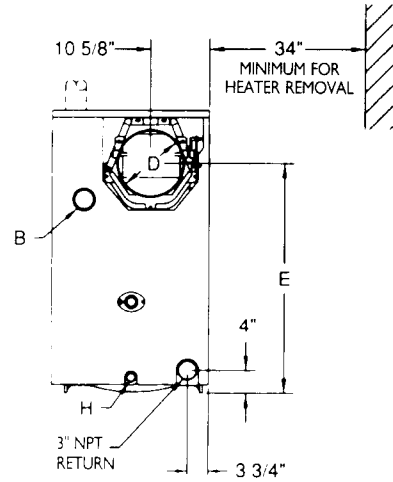

Back

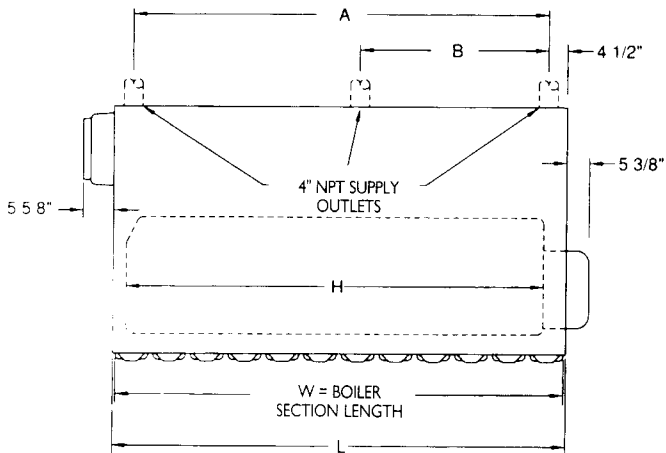

Side

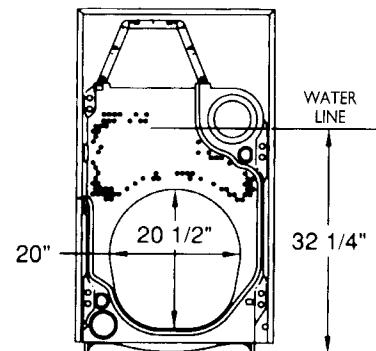

Intermediate

Section P: Parts

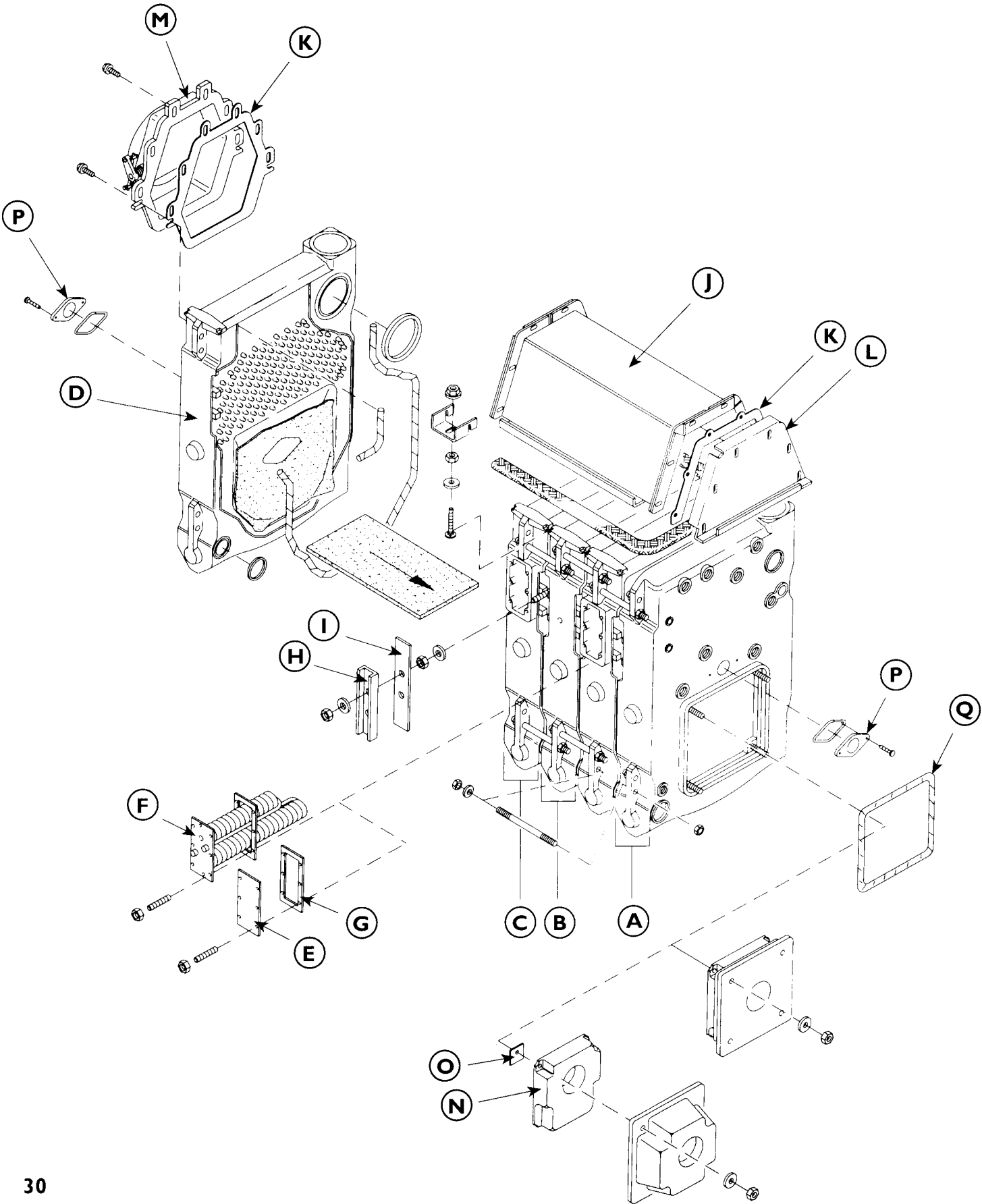

Section P: Parts

FIGURE NO.	DESCRIPTION	W-M SALES REF. NUMBER
A	FRONT SECTION (7813)	11B329
B	INTERMEDIATE SECTION REGULAR (7815)	11B330
	INTERMEDIATE SECTION SUPPLY - STEAM (7814)	11B331
C	INTERMEDIATE SECTION TANKLESS (7816)	11B332
D	BACK SECTION (7818)	11B333
	SECTION ASSEMBLY KIT (includes for one joint - sealing rope, sealing rope adhesive, sealing rings, silicone sealant, tie rods, washers, nuts)	11B334
E	HEATER COVER PLATE CARTON (includes cover plate, gasket, studs, nuts)	11B335
F	TANKLESS HEATER CARTON (includes tankless heater, gasket, studs, nuts)	11B336
G	HEATER GASKET	11B302
H	CLEANOUT PLATE	11B337
I	CLEANOUT PLATE GASKET	11B304
J	FLUE COLLECTOR HOOD "A"	11B338
	FLUE COLLECTOR HOOD "B"	11B339
	FLUE COLLECTOR HOOD "C"	11B340
	FLUE COLLECTOR HOOD "D"	11B341
	FLUE COLLECTOR HOOD "E"	11B351
	FLUE COLLECTOR HOOD HARDWARE KIT (includes flat-stitched sealing rope, double-faced tape, flue collar gasket, collector hood gaskets, holddown clips, hardware)	11B342
K	COLLECTOR HOOD GASKET KIT (Includes flue collector hood gasket, flue collar gasket, flat-stitched sealing rope and double-faced tape)	11B311
L	FLUE COLLECTOR HOOD END CAP	11B343
M	FLUE COLLAR ASSEMBLY 8"	11B344
	FLUE COLLAR ASSEMBLY 10"	11B345
	FLUE COLLAR ASSEMBLY 12"	11B346
	COMBUSTION CHAMBER KIT (includes back refractory blanket, bottom refractory blanket, waterglass, sealing rope, sealing rope adhesive)	11B348
N	BURNER MOUNTING PLATE FRONT REFRACTORY 4-1/2" BURNER OPENING	11B349
	BURNER MOUNTING PLATE FRONT REFRACTORY 6-1/8" BURNER OPENING	11B350
O	REFRACTORY RETAINER CLIP	10B960
P	OBSERVATION PORT ASSEMBLY (includes observation port assembly, sealing rope, screws)	11B300
Q	SEALING ROPE	10B985

Boiler Model	◆ I=B=R Burner Capacity		† Gross I=B=R Output MBH	†† Net I=B=R Ratings			Boiler H.P.	Net Firebox Volume Cu. Ft.	*** Stack Gas Volume CFM	□ Positive Pressure In Firebox In. W.C.	I=B=R Vent Dia. Inches	Boiler Water Content Gals.		Packaged Boiler Weight Less Water Lbs.
	** Light Oil GPH	○ ■ Gas MBH		Steam Sq. Ft.	■ Steam MBH	■ Water MBH						Water	Steam to Waterline	
▲ -378- * F ●	2.40	346	278	871	209	242	8.3	2.61	139	0.22	8	37.5	27.5	1355
▲ -478- * F ●	3.40	494	400	1250	300	348	11.9	3.97	198	0.22	8	49.0	36.0	1615
▲ -578- * F ●	4.45	641	521	1629	391	453	15.6	5.33	259	0.21	8	60.5	44.5	1875
▲ -678- * F ●	5.50	789	643	2008	482	559	19.2	6.69	320	0.21	8	72.0	53.0	2130
▲ -778- * F ●	6.50	937	764	2388	573	664	22.8	8.05	378	0.21	10	83.5	61.5	2390
▲ -878- * F ●	7.50	1084	886	2771	665	770	26.4	9.41	436	0.20	10	95.0	70.0	2650
▲ -978- * F ●	8.50	1232	1007	3154	755	876	30.1	10.77	494	0.20	10	106.5	78.5	2910
▲ -1078- * F ●	9.60	1379	1129	3533	847	982	33.7	12.13	558	0.20	10	118.0	87.0	3165
▲ -1178- * F ●	10.60	1527	1250	3917	938	1087	37.3	13.49	616	0.19	10	129.5	95.5	3425
▲ -1278- * F ●	11.60	1674	1372	4321	1039	1193	41.0	14.85	675	0.19	12	141.0	104.0	3680

- ▲ Use prefix "BL" for light oil, "BG" for gas, "BGL" for gas-light oil, or "H" for boiler only for use with approved burners. Add prefix "A" to designator for factory-assembled 78 (ABL-478). Substitute "P" for "B" for fire-tested package unit (PL-478).
- * Substitute "S" for steam, "W" for water.
- For T-Intermediate section(s) and tankless heater(s) add suffix "(number required) TIH"; for T-Intermediate section(s) with cover plate(s) only add suffix "(number required) TIP".
- ◆ Burner input based on maximum of 2,000 feet altitude - for higher altitudes consult Weil-McLain representative.
- ** No. 2 fuel oil - Commercial Standard Spec. CS75-56. Heat value of oil - 140,000 Btu/Gal.
- Consult Weil-McLain BURNER SPEC AND DATA SHEET for gas pressures required.
- MBH refers to thousands of Btu per hour.
- † Gross I=B=R ratings have been determined under the I=B=R provision governing forced draft boiler-burner units.
- †† Net I=B=R ratings are based on net installed radiation of sufficient quantity for the requirements of the building and nothing need be added for normal piping and pick-up. Water ratings are based on a piping and pick-up allowance of 1.15. Steam ratings are based on the following allowances: 378 through 1178 - 1.333; 1278 - 1.321. An additional allowance should be made for gravity hot water systems or for unusual piping and pick-up loads. Consult Weil-McLain representative.
- *** Stack gas volume at outlet temperature.
- With 0.10" W.C. positive pressure at flue collar.

Note: Sections tested for 60 PSIG working pressure. Water boilers available upon special request at 80 PSIG working pressure.