

GV90+

This Changes Everything... Weil-McLain Introduces The New GV90+

A 90+% AFUE efficient cast iron gas boiler
that can vent with PVC pipe material

- ▶ **UP TO 92% AFUE EFFICIENT**
- ▶ **DURABLE CAST IRON PRIMARY HEAT EXCHANGER**
- ▶ **CONDENSING STAINLESS STEEL SECONDARY HEAT EXCHANGER**
- ▶ **UNIQUE 7 PASS HEAT EXCHANGER DESIGN MAXIMIZES HEAT TRANSFER**
- ▶ **VENTS WITH PVC**
- ▶ **MULTIPLE VENTING OPTIONS**
DIRECT VENT, DIRECT EXHAUST, CONCENTRIC
- ▶ **EASY CONVERSION TO PROPANE-KIT INCLUDED**
- ▶ **APPLICATIONS INCLUDE:**
RESIDENTIAL
LIGHT COMMERCIAL
MULTIPLE BOILERS
INDIRECT-FIRED WATER HEATING
RADIANT HEATING
... AND MUCH MORE



DOE



GV90+
Series 2
Water,
Sealed Combustion
or Direct Exhaust,
NAT'L or LP,
MBH: 70-175



WEIL-McLAIN

www.weil-mclain.com

GV90+



Benefits that make it last...

• Maximum Heat Exchanger Performance

- Durable cast iron primary heat exchanger extends product life - it is not uncommon for cast iron boilers to last in excess of 40 years.
- Corrosion resistant stainless steel condensing secondary heat exchanger, increases efficiency up to 5% by recouping heat energy from exhaust normally wasted when vented from the building.

• Reliable Boiler Design

- Unlike most high efficiency boilers in the industry, the WM GV90+ has extra-wide waterways (over 2") allowing sludge and debris, often present in older systems, to flow through easily. This limits scale build up, which reduces boiler efficiency, performance and can lead to premature boiler failure.
- Down-fired, counter flow boiler design improves boiler efficiency. The GV90+ offers (5) pass design in the primary heat exchanger and (2) pass design in the secondary heat exchanger maximizing heat transfer and optimizing boiler efficiency.

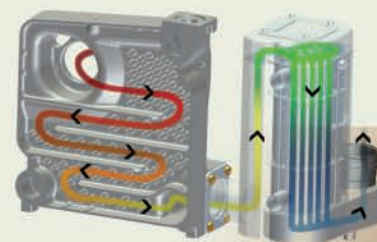

• Smart Circulator Strategy

- Built-in dual circulator strategy provides boiler protection - it can accept low return water temperatures (down to 60° F) with no additional mixing valves, pumps, wiring and installation labor - a savings of over \$500.
- The lower water temperature also allows homeowners the flexibility to add radiant heating for kitchens, baths or other living spaces without the added cost of special return temperature controls.

• Proven Control Strategy

- The control platform features error-proof, labeled, snap in connections. Tested at over 100,000 cycles, and boasting a failure rate of less than 1% over 20 years, it is sure to provide years of worry-free operation.
- Unlike traditional cast iron boilers, the GV90+ offers a unique control design allowing easy integration of outdoor reset to take advantage of low water temperatures and improve overall system energy cost savings.

Benefits that conserve...

- Exceeds Energy Star requirements with efficiency up to 92%
- Boiler sections made from recycled metals
- Lower emission levels than most boilers

... the GV90+ is one of the greenest cast iron boilers on the market



Benefits that pay...

Typical Yearly Energy Savings for New Boiler Installation by Region

Based on an average 2,000 sq. ft. home, results may vary depending on your area and utility rates.

Northeast Region				Midwest Region				West Region			
New Boiler Efficiency (AFUE)				New Boiler Efficiency (AFUE)				New Boiler Efficiency (AFUE)			
Current Boiler Efficiency (AFUE)	80%	85%	GV90+	80%	85%	GV90+	80%	85%	GV90+		
50%	\$736	\$809	\$895	\$572	\$628	\$695	\$617	\$677	\$750		
55%	\$558	\$630	\$717	\$433	\$489	\$557	\$467	\$528	\$601		
60%	\$409	\$481	\$568	\$318	\$374	\$441	\$343	\$403	\$476		
65%	\$283	\$355	\$442	\$220	\$276	\$343	\$237	\$298	\$370		
70%	\$175	\$248	\$334	\$136	\$192	\$260	\$147	\$207	\$280		

Natural Gas Price: \$1.18/therm (2011 DOE Projection) Natural Gas Price: \$0.92/therm (2011 DOE Projection) Natural Gas Price: \$1.23/therm (2010 WA State Avg.)

- Eligible for most utility rebate programs - check your local area for details and current rebate amounts.
- GV90+ is the first cast iron gas boiler vented with PVC — saving 90% over the cost of stainless steel venting material per foot.
- Simple diagnostics significantly reduces troubleshooting time by using flashing LED lights to communicate errors — no need to decipher codes or read lengthy manuals.

Benefits that provide comfort...

When matched with a Weil-McLain indirect-fired water heater, you will experience virtually limitless hot water for bathing, laundry, dishwashing and cooking at a lower operating cost compared to most other alternatives. Our indirect fired water heaters provide twice the peak flow of a tankless coil, 50% more than a comparable sized direct-fired gas water heater, and three times as much as an electric unit.



AQUA Plus
5 Tank Sizes
35-105

Why Weil-McLain...

- Full product line to satisfy every application
- Every residential gas boiler is hydrostatically tested to ASME standards and test fired
- Backed by Weil-McLain quality and a warranty that provides peace of mind
- Unrivalled technical and field sales support
- Ranked the #1 brand preferred by US HVAC contractors in 2008
- Over a 130 year proud history, and North America's leading boiler manufacturer

The New GV90+



www.weil-mclain.com

GV90+



AACSB CERTIFIED

DOE



Ratings

Model	Input MBH	DOE Heating Capacity MBH (1)	Net I=B=R Water Ratings MBH (2)	DOE Seasonal Efficiency AFUE %	Vent Diameter Inches (3)	Boiler Water Content Gal.
GV90+3	70	65	56	91.9	3	3.8
GV90+4	105	97	84	91.2	3	4.7
GV90+5	140	130	113	91.4	3	6.0
GV90+6	175	161	140	91.0	3	6.9

Notes:

- (1) Based on standard test procedures prescribed by the United States Department of Energy.
- (2) Net I=B=R ratings are based on net installed radiation of sufficient quantity for the requirements of the building and nothing needs to be added for normal piping and pick-up. Ratings are based on a piping and pick-up allowance of 115. An additional allowance should be made for unusual piping and pick-up loads.
- (3) GV90+ boilers must be vented directly to the outside.

Dimensions

Model	Length Inches L	Supply Tapping In.	Return Tapping In.	Gas Connection Size Inches	Minimum Recommended Pipe Size In.	Approx. Shipping Weight (Lbs)
GV90+3	30 3/4	1	1	1/2	1	313
GV90+4	30 3/4	1	1	1/2	1	353
GV90+5	37 3/4	1	1	1/2	1 1/4	423
GV90+6	37 3/4	1	1	1/2	1 1/4	464

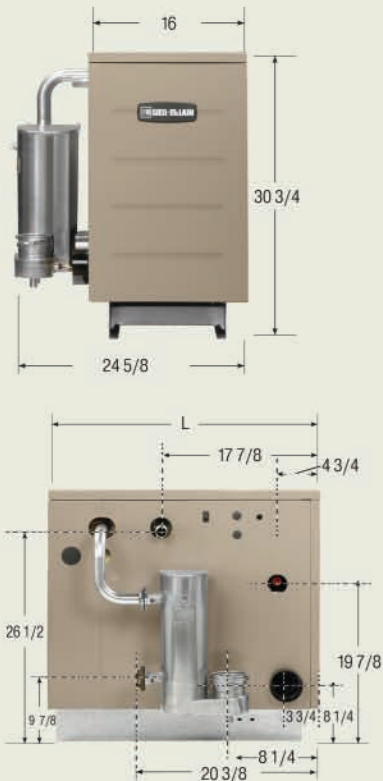

Installation Flexibility with Multiple Venting Options

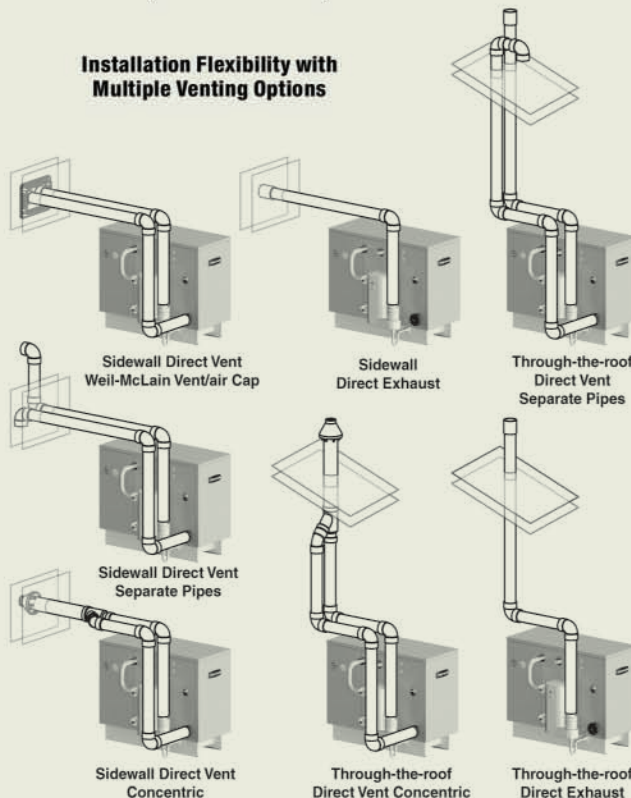

Standard Equipment

Standard Equipment:

- Factory Tested
- Insulated Extended Steel Jacket
- Cast Iron Sections with Built-in Air Separator
- Stainless Steel Secondary Heat Exchanger w/Air Separator
- Steel Base
- Control Module with Indicator Lights
- Blower Assembly with Observation Port
- Gas/Air Manifold Assembly
- Gas/Air Orifice Plate for Natural Gas (separate plate furnished for conversion to propane)
- Heat exchanger tested for 50 PSI working pressure)
- Negative Regulation Gas Valve
- Hot Surface Ignition System
- Air Pressure Switch
- System Circulator*
- Built-in-Bypass Circulator System with Sensor for Temperature Control*
- Condensate Drain Trap
- Sidewall Vent Termination Kit**
- 40VA Transformer
- Electrical Junction Box
- 30 PSI ASME Relief Valve (boiler sections & secondary heat exchanger tested for 50 PSI working pressure)
- Water Temperature Limit Switch
- Section Block Temperature Limit Switch
- Combination Pressure-Temperature Gauge
- Drain Valve
- Flue Thermal Fuse
- Water Treatment - Inhibitor & Test Kit

Additional Equipment:

- Concentric Vent Kit
- Condensate Neutralizer Kit
- Expansion Tank Package. #109-sizes 3 thru 5; #110-size 6. Shipped in separate carton.
- High Altitude Kit
- W-M 5 & 10 Year Homeowner Protection Plan
- W-M Indirect-fired Water Heaters
- W-M Pool Heaters
- W-M Baseboard Units

*Circulators supplied with boiler cannot be removed and cannot be used as a zone circulator in multiple zone systems.

** Includes inside and outside plates, vent cap and hardware.



In the interest of continual improvements in product and performance, Weil-McLain reserves the right to change specifications without notice.

