



Gas Stoves



## A passion for both tradition and change

Our new catalogue brings to you, as always, the latest in our collection. You will discover the products that have already contributed to the success of our company for years, as well as the significant introduction of new products. Diversity and individuality are some of the most important qualities of our time. Never has the range of styles been so vast. Never has the question of personal preference been so open.

### Wood burning is CO<sub>2</sub> neutral bioenergy

We think it is important to focus on how each individual can contribute in taking care of our planet's resources. Wood burning is an alternative heating method that saves both the household budget and the environment. Wood logs burning in the stove or insert produce the same amount of CO<sub>2</sub> as the air a tree has absorbed during its lifespan. Further, it is good to know that when the tree is felled it gives room for a new plant, and the process can be repeated. Hence, we

utilize a renewable and sustainable energy source without destroying it, and without increasing the concentration of CO<sub>2</sub> in the atmosphere.

### Sustainability

Fortunately for our customers through many years, Jøtul's environmental focus has been strong from the late 1980's. We believe that sustainability is important through the whole life cycle of our products. You can read about our warmth philosophy in this brochure, and much more about our production and products on [www.jotul.com](http://www.jotul.com).

Going forward, we promise to continue our focus on innovation, forward thinking, and above all the desire to connect our stoves and fireplaces with the people who use them, so our company and products stay with the times.

### Design awards

Our efforts have been rewarded several times with design awards in several countries. Amongst others

is the coveted title "red dot: best of the best" for the Jøtul F 373.

It is of course wonderful to receive top-class recognition, but we cannot rest on our laurels. At the end of the day, there is nothing more important to Jøtul than leaving the people who purchase our products with a very definite feeling; that of having bought exactly the right piece. To us, there is nothing more important than this.

So, now, I invite you to sit back, relax and enjoy our catalogue – then close your eyes and dream of what a Jøtul product will do to your home!

... in the spirit of our time, and in the spirit of Jøtul.



Erik Moe, President & CEO

experience the spirit of Jøtul

## Contents

Introduction	2
Jøtul's Warmth Philosophy	4
<hr/>	
Jøtul GF 100 DV II Nordic QT	6
Jøtul GF 200 DV II Lillehammer	8
Jøtul GF 300 DV/BV Allagash	10
Jøtul GF 400 DV/BV Sebago	12
Jøtul GF 600 DV II Firelight	14
<hr/>	
JøtulBurner™/Jøtul Heat Fin™	16
Gas Vent Guidelines	18
Technical Specifications	19



# Jøtul's Warmth Philosophy

Where most people consider warmth to mean heating and cosiness, experience has taught us there is much more to it than that. In fact, there are six types of warmth: physical warmth and atmospheric warmth, in addition to visual, convenient, durable and sustainable warmth.

We combine our warmth philosophy, "Warmth in every detail," with a rich tradition of fine craftsmanship. In doing so we design cast iron stoves and fireplaces that create the ultimate warmth experience.

## Physical warmth

To us, heating is not about creating the highest temperature, it is about creating the most comfortable temperature. Due to an optimum combination of convected and radiated heat our products can provide the most comfortable heat, in the most efficient manner. Furthermore, our clean burn technology ensures that practically all the particles and gasses in the smoke are burned.



## Atmospheric warmth

Nothing creates an intimate atmosphere quite like a gently crackling fire. And nothing calms you quite like the image of a flame dancing hypnotically on a glowing log. We have always believed in the seductive powers of the visible flame. For this reason, we have developed pioneering flame technology to achieve the perfect flame at all times.



## Visual warmth

The atmosphere produced by a stove or fireplace is largely dependent on the aesthetic message it sends out. We aim to create a lasting impression in the home and follow our own "design for generations" ideal to give our stoves and fireplaces a timeless appeal. We collaborate with acclaimed design houses in order to design award-winning stoves and fireplaces that outlive trends and retain their timeless beauty for decades.

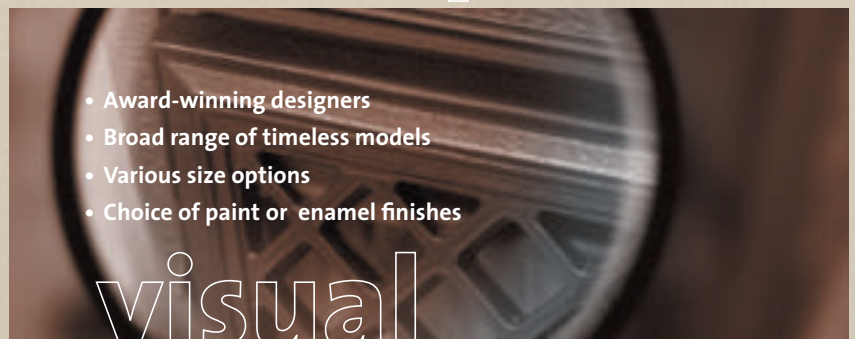





#### **Convenient warmth**

We put an enormous amount of effort into our hearth products so our customers don't have to. The hearth is the center-piece of the home – it is an essential part of everyday life – and for this reason it should represent total functionality. Everything about a Jøtul product is geared towards our customers' convenience: it is easy to install, easy to use, easy to clean and easy to maintain. Life is already complicated enough, so we make its pleasures a little easier to enjoy.

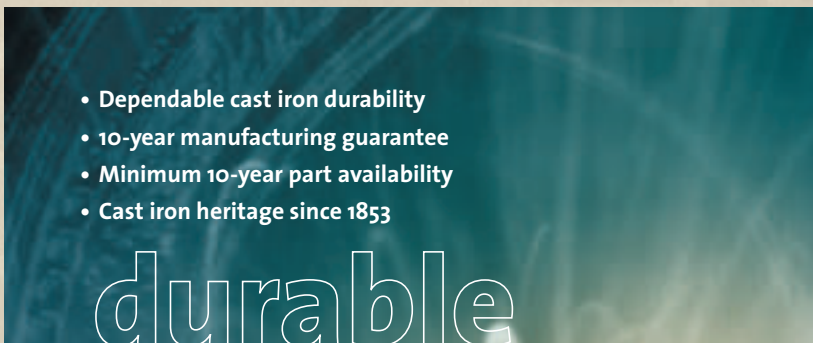

- Dependable cast iron durability
- 10-year manufacturing guarantee
- Minimum 10-year part availability
- Cast iron heritage since 1853

#### **Durable warmth**

Owning a Jøtul stove or fireplace is a lasting experience. Since 1853 we have employed the finest handcrafting techniques in order to provide our customers with long-lasting, durable warmth. Warmth they can trust. Because where fire is involved, safety and security are vital. Cast iron delivers the highest standard of strength and durability. As one of the world's oldest cast iron stove and fireplace manufacturers, no company delivers a longer lasting promise of quality.



#### **Sustainable warmth**

Our understanding of warmth enables us to create the ultimate experience of warmth. All the cast iron we use is recycled. And by relying mostly on hydroelectric power to smelt recycled iron, we keep polluting emissions to an absolute minimum. Furthermore, our clean burn technology ensures that our products boast the most efficient use of energy which also reduces the volumes of particles emitted locally. This means our customers can light their hearth products with minimal effect on the environment.

# Jøtul GF 100 DV II Nordic QT

## Direct Vent Gas Stove

Utilizing a traditional Norwegian sweater pattern design, world-renowned Red House Design in conjunction with our well-regarded team of in-house design engineers, developed the first freestanding zero clearance high efficiency gas stove - the Jøtul GF 100 DV II Nordic QT. Designed with easy, low cost installations in mind, this stove is perfect for your bedroom, bathroom or any other smaller living area. Just as important, the Jøtul GF 100 DV II Nordic QT comes equipped with Jøtul's revolutionary cast iron and stainless steel burner, the JøtulBurner™. Popular options include: wall thermostat, mobile home approved floor bracket kit, variable speed blower fan kit, antique brick panel kit, remote control, a choice of enamel colors and our Jøtul Iron™ or Classic Matte Black Paint.



JøtulBurner™

### Options

*Antique brick panel kit (molded from real brick)*

*Wall thermostat*

*Remote control*

*Variable speed blower fan kit*

*Floor bracket kit (for mobile home installations)*

*Choice of four porcelain enamel colors*

*Jøtul Iron™ or Classic Matte Black Paint*

*Leg leveler kit*



### Features

Revolutionary new JøtulBurner™ delivers unsurpassed gas burner technology and flame picture realism (Patent # 7004751)

50% heat control turn down

Handcrafted ceramic fiber log set burns with the glowing warmth of a real wood fire

Durable, furniture quality cast iron construction

No electricity required to operate

Zero clearance rear vent capability

Ability to corner vent without snorkel or tall cap

Large fire viewing area

ON/OFF Thermostat switch

Natural convection for increased air circulation

Vent restrictors included for vertical terminations

Conversion kit included for use with propane gas

Mobile home approved

5 year limited warranty

<i>Classic Matte Black Paint</i>	
<i>Jøtul Iron™ Paint</i>	
<i>Jøtul Iron™ Porcelain Enamel</i>	
<i>Blue/Black Porcelain Enamel</i>	
<i>Blue Majolica Porcelain Enamel</i>	
<i>Brown Majolica Porcelain Enamel</i>	





Jøtul GF 100 DV II Nordic QT

*Jøtul GF 100 DV II Nordic QT shown here in Ivory Porcelain Enamel and optional antique brick panel kit*

# Jøtul GF 200 DV II Lillehammer

## Direct Vent Gas Stove

Designed in collaboration with world-renowned Red House Design and our well-regarded in-house design engineering staff, the Jøtul GF 200 DV II Lillehammer brings into your home a touch of Scandinavian charm and warmth reminiscent of the 1994 Winter Olympics in Lillehammer, Norway. We challenge you to find another stove among the competition possessing the same crisp lines and sharp features that define world class craftsmanship and foundry capabilities. Popular options include: variable speed blower fan kit, antique brick panel kit (molded from real brick), screen for open door fire viewing, floor bracket kit (for mobile home installations), wall thermostat, remote control, a choice of enamel colors and our Jøtul Iron™ or Classic Matte Black Paint.



JøtulBurner™

### Options

*Antique brick panel kit (molded from real brick)*

*Wall thermostat*

*Variable speed blower fan kit*

*Screen for open door fire viewing*

*Remote control*

*Floor bracket kit (for mobile home installations)*

*Choice of plinth or long legs (8")*

*Choice of four porcelain enamel colors*

*Jøtul Iron™ or Classic Matte Black Paint*

*Leg leveler kit*



### Features

Revolutionary new JøtulBurner™ delivers unsurpassed gas burner technology and flame picture realism (Patent #7004751)

50% heat control turn down

Durable, furniture quality cast iron construction

ON/OFF thermostat switch

Handcrafted ceramic fiber log set burns with the glowing warmth of a real wood fire

Ability to corner vent without snorkel or tall cap

Conversion kit included for use with propane gas

No electricity required; easy-to-operate ignition system

Zero clearance rear vent capability

Natural convection for increased air circulation

Vent restrictors included for vertical terminations

Mobile home approved

5 year limited warranty

Classic Matte Black Paint	
Jøtul Iron™ Paint	
Ivory Porcelain Enamel	
Blue/Black Porcelain Enamel	
Blue Majolica Porcelain Enamel	
Brown Majolica Porcelain Enamel	





Jøtul GF 200 DV II Lillehammer

*Jøtul GF 200 DV II Lillehammer shown here in Majolica Blue Porcelain Enamel, optional antique brick panel kit, and fire screen*

# Jøtul GF 300 DV/BV Allagash



*JøtulBurner™*

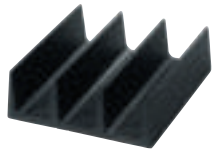

*Jøtul Heat Fin™*

## Direct Vent or B-vent Gas Stove

As rugged as the wilderness waterway that bears its name, world-renowned Red House Design and our team of in-house design engineers made sure that our Jøtul GF 300 DV/BV Allagash presents the perfect union of high efficiency and cast iron beauty. Its classic lines and Gothic arch double doors frame a hand-crafted log set, flame and glowing embers with a realism unrivaled in the hearth industry. Fueled by the quiet durability of our revolutionary new cast iron and stainless steel burner - the JøtulBurner™ - this stove is the best-selling gas stove in the long history of Jøtul. Popular options include: antique brick panel kit, remote control, fire screen for open door viewing, short leg kit for fireplace installations, a choice enamel colors and Jøtul Iron™ or Classic Matte Black Paint.

### Options

*Antique brick panel kit (molded from real brick)*

*Wall thermostat*

*Remote control*

*Floor bracket kit (for mobile home installations)*

*Top plate filler (for B-vent rear exit installations only)*

*Variable speed blower fan kit*

*Screen for open door fire viewing*

*Short leg kit for fireplace installations (reduces height by 2 1/4")*

*Choice of four porcelain enamel colors*

*Jøtul Iron™ or Classic Matte Black Paint*

*Leg leveler kit*



### Features

Revolutionary new JøtulBurner™ delivers unsurpassed gas burner technology and flame picture realism (Patent #7004751)

Handcrafted ceramic fiber log set burns with the glowing warmth of a real wood fire

Standard reversible flue collar for top or rear exit capability

Large fire viewing area with open door capability – an industry pioneer!

Durable, furniture quality cast iron construction

ON/OFF Thermostat switch

Natural convection for increased air circulation

Vent restrictors included for vertical terminations (Direct Vent only)

Jøtul Heat Fin™ technology means great heating capacity with a minimum of heat loss

Pre-wired for blower fan kit

No electricity required to operate stove

Conversion kit included for use with propane gas

5 year limited warranty

<i>Classic Matte Black Paint</i>	
<i>Jøtul Iron™ Paint</i>	
<i>Blue/Black Porcelain Enamel</i>	
<i>Ivory Porcelain Enamel</i>	
<i>Blue Majolica Porcelain Enamel</i>	
<i>Brown Majolica Porcelain Enamel</i>	





Jøtul GF 300 DV Allagash

*Jøtul GF 300 DV Allagash shown here in Blue/Black  
Porcelain Enamel with optional antique brick panel  
kit and fire screen*



# Jøtul GF 400 DV/BV Sebago



*JøtulBurner™*

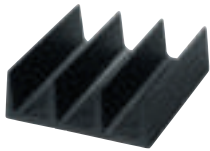

*Jøtul Heat Fin™*

## Direct Vent or B-Vent Gas Stove

Red House Design, in collaboration with our well-regarded in-house design engineers, created this Vesta Design and Technology Award finalist with beauty and high efficiency operation in mind. With its nautical theme that takes your mind off to sea from the shores of Norway or Maine, the Jøtul GF 400 DV or BV Sebago is our latest addition to the Jøtul Family. This stove incorporates our innovative new cast iron and stainless steel JøtulBurner™ - a revolution in gas flame technology. With a hand crafted log set and double door design, this stove demonstrates why Jøtul is widely recognized as the cast iron leader in quality and craftsmanship. Popular options include: antique brick panel kit, screen for open door fire-viewing, remote control and a choice of colors.

## Options

*Antique brick panel kit (molded from real brick)*

*Wall thermostat*

*Remote control*

*Floor bracket kit (for mobile home installations)*

*Variable speed blower fan kit*

*Screen for open door fire viewing*

*Short leg kit for fireplace installations*

*(reduces height by 2 1/4")*

*Choice of four porcelain enamel colors*

*Jøtul Iron™ or Classic Matte Black Paint*

*Leg leveler kit*



## Features

Revolutionary new JøtulBurner™ delivers unsurpassed gas burner technology and flame picture realism (Patent #7004751)

Handcrafted ceramic fiber log set burns with the glowing warmth of a real wood fire

Standard reversible flue collar for top or rear exit capability

Large fire viewing area with open door capability – an industry pioneer!

Durable, furniture quality cast iron construction

ON/OFF Thermostat switch

Vent restrictors included for vertical terminations

Jøtul Heat Fin™ technology means great heating capacity with a minimum of heat loss

Pre-wired for blower fan kit

No electricity required to operate stove

Conversion kit included for use with propane gas

5 year limited warranty

<i>Classic Matte Black Paint</i>	
<i>Jøtul Iron™ Paint</i>	
<i>Blue/Black Porcelain Enamel</i>	
<i>Ivory Porcelain Enamel</i>	
<i>Blue Majolica Porcelain Enamel</i>	
<i>Brown Majolica Porcelain Enamel</i>	



Jøtul GF 400 DV/BV Sebago

*Jøtul GF 400 DV Sebago shown here in Majolica Brown Porcelain Enamel with optional antique brick panel kit and fire screen*

# Jøtul GF 600 DV II Firelight

## Direct Vent Gas Stove

A descendent of our signature Jøtul F 600 Firelight CB wood stove, the Jøtul GF 600 DV II Firelight provides the same double door, open fire viewing and classic design that put Jøtul on the wood burning map in North America. Without any doubt, this stove has an unparalleled flame picture fueled by Jøtul's revolutionary cast iron and stainless steel burner, the JøtulBurner™. With it's 50% heat control turn down capability, the Jøtul GF 600 DV II Firelight fulfills the heat requirements of a variety of living spaces and can be used as a primary heat source. Popular options include: screen for open door fire viewing, antique brick panel kit, remote control, variable speed blower fan kit, a choice of four enamel colors and Jøtul Iron™ or Classic Matte Black Paint.



JøtulBurner™

### Options

*Screen for open door fire viewing*

*Antique brick panel kit (molded from real brick)*

*Wall thermostat*

*Remote control*

*Floor bracket kit (for mobile home installations)*

*Variable speed blower fan kit*

*Choice of four porcelain enamel colors*

*Jøtul Iron™ or Matte Black Paint*



### Features

Revolutionary new JøtulBurner™ delivers unsurpassed gas burner technology and flame picture realism (Patent #7004751)

50% heat control turn down

Largest fire viewing area available in a freestanding gas stove with open door fire viewing

Hand-crafted ceramic fiber log set burns with the glowing warmth of a real wood fire

Conversion kit included for use with propane gas

No electricity required; easy-to-operate ignition system

ON/OFF Thermostat switch

Standard reversible flue for top or rear exit capability

Vent restrictors included for vertical terminations

Mobile home approved

5 year limited warranty

Classic Matte Black Paint	
Jøtul Iron™ Paint	
Blue/Black Porcelain Enamel	
Ivory Porcelain Enamel	
Blue Majolica Porcelain Enamel	
Brown Majolica Porcelain Enamel	



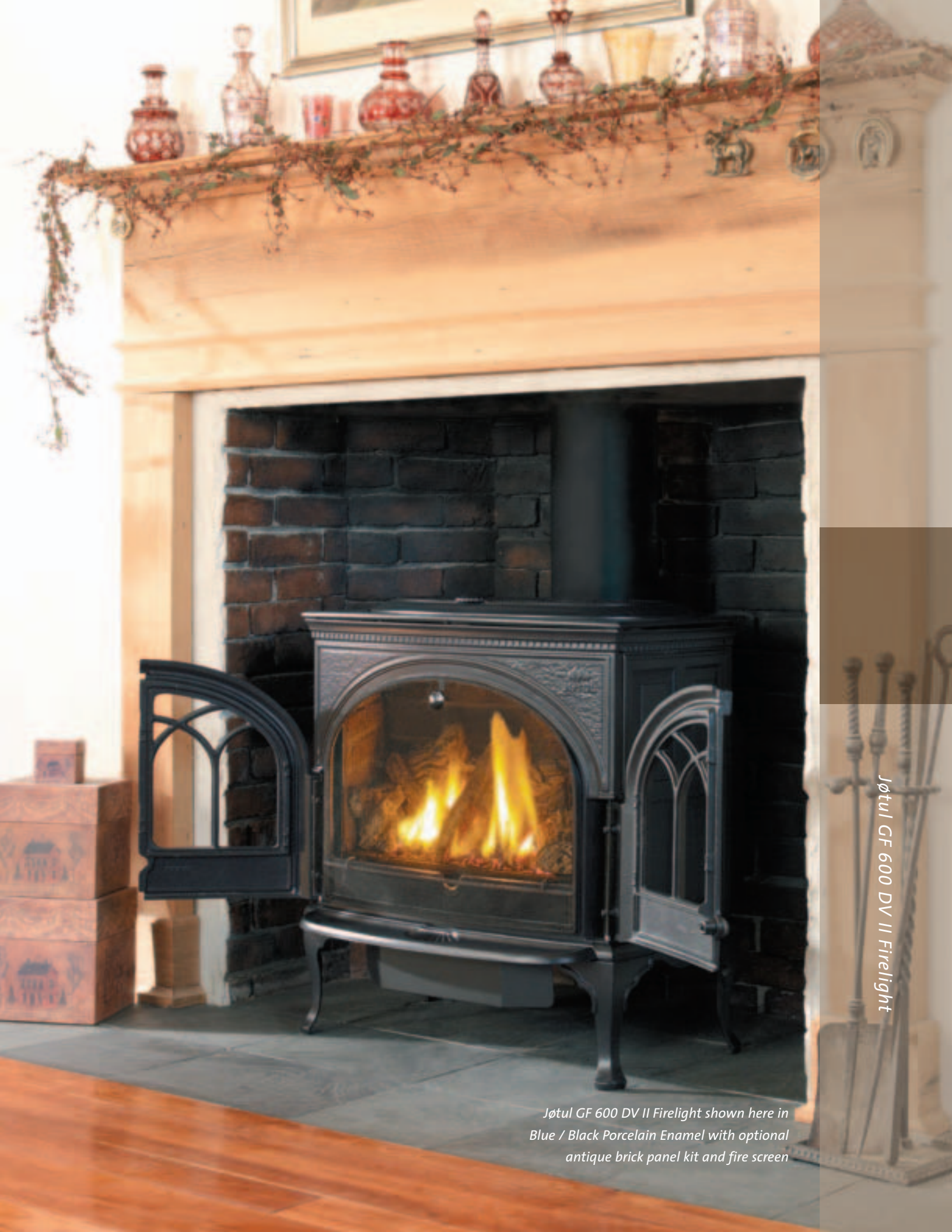

Jøtul GF 600 DV II Firelight

*Jøtul GF 600 DV II Firelight shown here in Blue / Black Porcelain Enamel with optional antique brick panel kit and fire screen*

# JøtulBurner™/Heat Fin™ Technology

This cutaway view of the Jøtul GF 300 DV Allagash illustrates the air flow through a direct vent system and also how the fire's heat is transferred into your home. Fresh air enters through the outer vent pipe and is directed to the bottom of the firebox to mix with gas inside and above the JøtulBurner™ (Patent #7004751).

Gas enters the burner through a control valve, mixes with combustion air and passes through the burner porting where it ignites, creating a realistic “wood-burning” flame. Exhaust gas exits out of the system through the inner vent pipe.

All Jøtul gas stoves deliver heat to your home in two ways; radiant and convection air. Radiant heat is given off through the large front glass panel and off of the cast iron plates of the stove itself. Convection heat is produced by air that is heated as it flows around the firebox and over the Jøtul Heat Fins™ at the top of the firebox, before passing through the expansive latticework of the top plate. An optional blower can be added to aid the convection process.

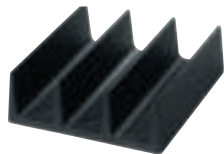

*Jøtul Heat Fin™*

## **Jøtul Heat Fin™**

Jøtul's patented Heat Fin™ technology allows for exceptional heat transference. Made of quality Jøtul materials, the fins create natural heat channels that extract heat from the appliance and into your home.



*JøtulBurner™*

## **JøtulBurner™ (patent #7004751)**

The JøtulBurner™ is constructed of a quality cast iron base mated to a heavy-grade stainless steel porting plate. Our custom machine process “crimps” these parts together allowing the top to “float” on the base, thereby alleviating stress and providing great durability.

- Incoming air
- Gas
- Exhaust
- Convection air (heat)





# Gas Vent Guidelines

## Direct Vent Systems

A direct vent gas appliance is a closed combustion system that takes its combustion air from outside the home. Using either a co-axial pipe (a pipe within a pipe) or a co-linear system to both take air in for combustion and exhaust products of combustion.



## Co-axial Vent

A co-axial vent consists of a smaller pipe within a larger pipe, most commonly a 4-inch pipe inside a 6 5/8 inch pipe. This type of venting pipe is used when the venting runs horizontally and passes through an outside wall, or vertically to penetrate the roof. A specific termination cap is used that separates exhaust gases from the incoming combustion air.

## Co-linear Vent

A co-linear venting system is used for direct vent gas fireplace inserts and freestanding gas stoves when installed in front of existing masonry fireplaces. This venting system consists of two 3-inch flexible liners that are run up a masonry chimney. One liner is used for the air intake and the other for exhaust. The liners are attached to adapters on the unit, run up the flue and then connect to a co-linear adapter on the top of the chimney, to which the direct vent cap is secured. When used with a freestanding stove, a co-linear adapter is also attached to the stove to convert the co-axial pipe to the co-linear venting system.

## B-Vent Systems

A B-vent or natural draft system is often vented into masonry or class A chimney system. Stoves using this type of venting use room air for combustion and exhaust the products of combustion into a chimney. When using a masonry chimney, a 4-inch aluminum gas liner must be installed.



### Jøtul GF 100 DV II Nordic QT

Page 6

#### Venting Options & Specifications

Venting	Direct Vent
Heating Capacity <sup>1</sup>	Up to 600 sq. ft.
Min/Max Heat Input (BTU/hr)	9,900-17,000 (NG) 8,700-16,000 (LP)
Efficiency <sup>3</sup>	up to 87% Steady State (A.F.U.E. 73%)

Safety Features	Sealed System
Optional Blower	Yes
Optional Wall Thermostat	Yes
Optional Remote control	Yes

#### Dimensions

Height	22 1/4"
Height w/ opt. short legs	n/a
Width	21"
Depth <sup>2</sup>	16 3/4"
Weight	150 lbs.
Venting	Simpson DuraVent GS/ AmeriVent/Security/Selkirk

#### Clearances

Rear	0" (zero clearance)
Side	3"
Corner	2"
9 1/2" deep mantel	27 3/4"

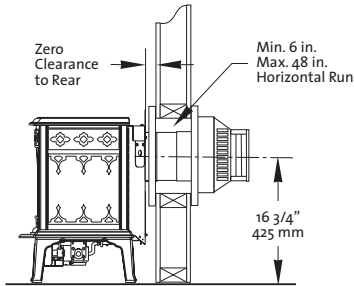

### Jøtul GF 200 DV II Lillehammer

Page 8

Venting	Direct Vent
Heating Capacity <sup>1</sup>	Up to 800 sq. ft.
Min/Max Heat Input (BTU/hr)	11,400-20,000 (NG) 8,440-18,000 (LP)
Efficiency <sup>3</sup>	up to 87% Steady State (A.F.U.E. 73%)

Safety Features	Sealed System
Optional Blower	Yes
Optional Wall Thermostat	Yes
Optional Remote control	Yes

#### Dimensions

Height	24 3/4"
Height w/ opt. short legs	n/a
Width	22 3/4"
Depth <sup>2</sup>	18 1/2"
Weight	190 lbs.
Venting	Simpson DuraVent GS/ AmeriVent/Security/Selkirk

#### Clearances

Rear	0" (zero clearance)
Side	3"
Corner	2"
9 1/2" deep mantel	27 3/4"

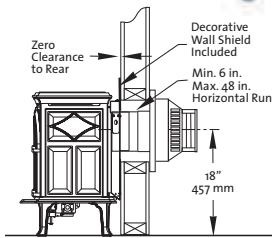

#### Leg Styles & Sizes

<sup>1</sup> Heating Capacity will vary depending on the design of the home, climate, operation and venting configuration.

<sup>2</sup> Depth dimension includes ashlip and flue collar.

<sup>3</sup> With maximum vent configuration

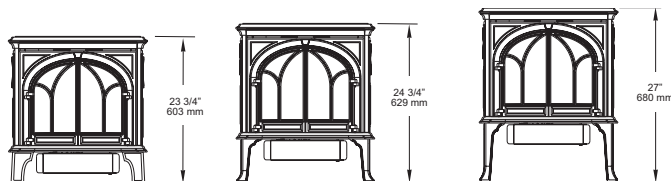



**Jøtul GF 300 BV Allagash**

Page 10

**Venting Options & Specifications**

Venting	B-Vent
Heating Capacity <sup>1</sup>	Up to 1,300 sq.ft.
Min/Max Heat Input (BTU/hr)	15,000-26,000 (NG) 13,500-26,000 (LP)
Efficiency <sup>3</sup>	up to 86% Steady State (A.F.U.E. 73%)
Safety Features	Sealed System
Optional Blower	Yes
Optional Wall Thermostat	Yes
Optional Remote control	Yes

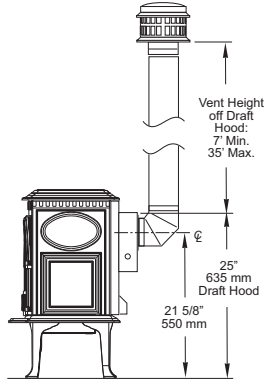

**Dimensions**

Height	27 3/4"
Height w/ opt. short legs	25 1/2"
Width	22 3/4"
Depth <sup>2</sup>	17 1/2"
Weight	185 lbs.
Venting	4" B-Vent

**Clearances**

Rear	2"
Side	3"
Corner	3"
11.5" deep mantel	29"



**Jøtul GF 300 DV Allagash**

Page 10

Venting	Direct Vent
Heating Capacity <sup>1</sup>	Up to 1,300 sq. ft..
Min/Max Heat Input (BTU/hr)	14,000-26,000 (NG) 14,000-26,000 (LP)
Efficiency <sup>3</sup>	up to 88% Steady State (A.F.U.E. 72.7%)
Safety Features	Sealed System
Optional Blower	Yes
Optional Wall Thermostat	Yes
Optional Remote control	Yes

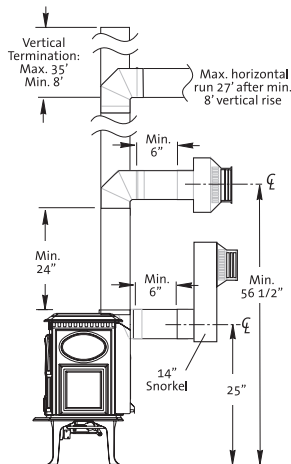

**Dimensions**

Height	28"
Height w/ opt. short legs	25 3/4"
Width	22 3/4"
Depth <sup>2</sup>	17 1/2"
Weight	185 lbs.
Venting	Simpson DuraVent GS/ AmeriVent/Security/Selkirk

**Clearances**

Rear	2"
Side	3"
Corner	2"
10" deep mantel	29"

<sup>1</sup> Heating Capacity will vary depending on the design of the home, climate, elevation, operation and venting configuration.

<sup>2</sup> Depth dimension includes ashlip and flue collar.

<sup>3</sup> With maximum vent configuration





### Jøtul GF 400 BV Sebago

Page 12

#### Venting Options & Specifications

Venting	B-Vent
Heating Capacity <sup>1</sup>	Up to 2,000 sq. ft.
Min/Max Heat Input (BTU/hr)	22,000-40,000 (NG) 20,000-40,000 (LP)
Efficiency <sup>3</sup>	up to 88% Steady State (A.F.U.E. 73.5%)

Safety Features	Safety switch
Optional Blower	Yes
Optional Wall Thermostat	Yes
Optional Remote control	Yes

#### Dimensions

Height	28 1/2"
Height w/ opt. short legs	26 1/4"
Width	26 1/2"
Depth <sup>2</sup>	24"
Weight	190 lbs.
Venting	4" B-Vent

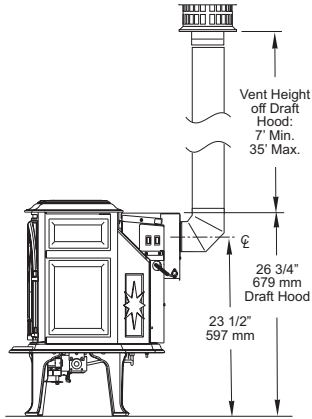

#### Clearances

Rear	3"
Side	3"
Corner	3"
10.25" deep mantel	25 1/4"



### Jøtul GF 400 DV Sebago

Page 12

Venting	Direct Vent
Heating Capacity <sup>1</sup>	Up to 1,500 sq. ft.
Min/Max Heat Input (BTU/hr)	18,000-32,000 (NG) 16,000-32,000 (LP)
Efficiency <sup>3</sup>	up to 88% Steady State (A.F.U.E. 73%)

Safety Features	Sealed System
Optional Blower	Yes
Optional Wall Thermostat	Yes
Optional Remote control	Yes

#### Dimensions

Height	28 1/2"
Height w/ opt. short legs	26 1/4"
Width	26 1/4"
Depth <sup>2</sup>	26 1/2"
Weight	190 lbs.
Venting	Simpson DuraVent GS/ AmeriVent/Security/Selkirk

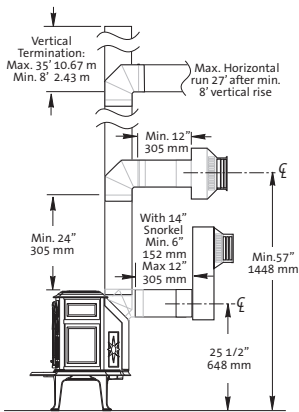

#### Clearances

Rear	2"
Side	3"
Corner	2"
10" deep mantel	18"

<sup>1</sup> Heating Capacity will vary depending on the design of the home, climate, elevation, operation and venting configuration.

<sup>2</sup> Depth dimension includes ashlip and flue collar.

<sup>3</sup> With maximum vent configuration



**Jøtul GF 600 DV II Firelight** Page 14

**Venting Options & Specifications**

Venting	Direct Vent
Heating Capacity <sup>1</sup>	Up to 2,000 sq.ft.
Min/Max Heat Input (BTU/hr)	23,900-40,000 (NG) 20,300-40,000 (LP)
Efficiency <sup>3</sup>	up to 87% Steady State (A.F.U.E. 73.5%)

Safety Features	Sealed System
Optional Blower	Yes
Optional Wall Thermostat	Yes
Optional Remote control	Yes

**Dimensions**

Height	31"
Height w/ opt. short legs	n/a
Width	29"
Depth <sup>2</sup>	24"
Weight	260 lbs.
Venting	Simpson DuraVent GS/AmeriVent/ Security/Selkirk

**Clearances**

Rear	2"
Side	3"
Corner	3"
11 1/2" deep mantel	11"

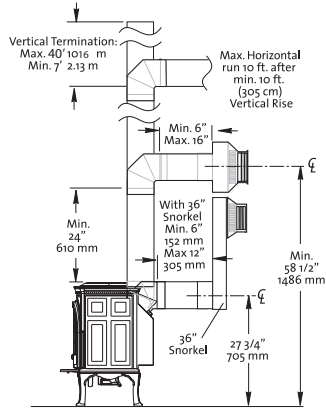

**Hearth Requirements**

Jøtul gas stoves cannot be installed directly on carpeting, vinyl, linoleum or Pergo™. If this appliance will be installed on any combustible material other than wood, a floor pad must be installed that is either metal or wood, or a listed hearth pad. This floor protection must extend the full width and depth of the appliance. It is not necessary to remove carpeting, vinyl or linoleum from underneath the floor protection.

<sup>1</sup>Heating Capacity will vary depending on the design of the home, climate, elevation, operation and venting configuration.

<sup>2</sup>Depth dimension includes ashlip and flue collar.

<sup>3</sup>With maximum vent configuration



### **Warranty**

Our 5 year warranty: a cast iron promise of quality. Jøtul guarantees the quality of its cast iron components against any defects in materials or workmanship for five years, subject to the exclusions and limitations noted on our warranty. For complete details, ask your Authorized Jøtul Dealer.

### **Installation**

Specifications and dimensions published in this brochure are intended to be used as guidelines for comparison only. Always consult the owner's manual in planning any installation. Specifications and dimensions are subject to change without notice. Contact local building or fire officials regarding restrictions and installation inspection requirements in your area.

### **Photographs**

Some settings for the photographs are for aesthetic purposes only and may not comply with installation requirements. Materials, specifications, accessories, colors, and models are subject to change without notice. Some models are shown with optional accessories.

BTU ratings are to be used as a guideline only, and do not imply a guarantee of the heating capacity of the unit.



Ask your authorized Jøtul Group Dealer about our full line of cast iron wood and gas stoves, inserts and fireplaces.



A Jøtul Group Company  
Jøtul North America  
55 Hutcherson Drive  
Gorham, Maine 04038

[www.jotul.us](http://www.jotul.us)

Printed in U.S.A.  
July 2009

Gas Stove

