



HVAC ENGINEERED PRODUCTS



**SINGLE AND MULTIPLE OUTDOOR
DUCT FURNACE ARRANGEMENTS
FOR MAKEUP AIR, HEATING
AND COOLING**

General Information

Sterling Quality

Sterling HVAC Products, a division of Mestek, has been a leading producer of quality engineered and manufactured HVAC equipment for over 50 years. This experience has allowed us to design and manufacture a complete line of outdoor equipment suitable for commercial, institutional and industrial applications. Our wide range of modular mechanical and electrical components allow custom unit selection in a standard package, providing outstanding versatility, performance and reliability you've come to expect from Sterling. Our expert engineering staff is always available to provide professional assistance in any phase of your project from preliminary planning to installation and operation.

Sterling Engineered Products Rooftop Units have incorporated a multi digit "Model Number" in order to more comprehensively describe the product. With the Sterling Engineered Products "Model Number" we can now offer the vast array of features found in this catalog to meet your ever demanding applications as "Standard Equipment for Sterling".

Engineered Product Description

Sterling Rooftop Units

The Sterling Engineered Products Rooftop is a packaged air, heating and cooling system, suitable for heating, cooling, ventilating and makeup air applications. Unit sizes range from 800 to 14,000 CFM (0.4-6.6 m³/s) with 1/2-15 HP. motors and 100,000 BTU/Hr to 1,200,000 BTU/Hr (29.3 to 351.4 kW) input. Duct furnaces are "AGA" and "CGA" certified for safety and performance with a range of 100,000 to 400,000 BTU/Hr (29.3 to 117.1 kW) input per duct furnace. Packaged units are also "ETL" and "CSA" certified for electrical safety in compliance with "UL-1995" Standard for HVAC Equipment. Sterling Rooftop Units may be ordered as individual Duct Furnaces only, Air Handler only, Air Handler with Cooling, Evaporative Cooling only or Packaged Heating and Cooling Systems.

The mechanical configuration is determined by customer selection and may consist of one of 17 standard arrangements (see "Rooftop Arrangements" [RA], model number digit 7). Rooftop Arrangements are divided into two classifications "Standard" and "High CFM" Blower types. The "Standard" Blower unit consist of a blower cabinet that houses dampers, filters and blower in one cabinet, an optional Evaporative cooling unit and up to 2 Duct Furnaces (800 MBH Max.) (234.3 kW

Max.) may also be included. The "High CFM" blower unit utilizes a separate Damper/Filter cabinet with a "V" bank filter arrangement, a Blower cabinet and up to 3 Duct Furnaces (1200 MBH Max.) (351.4 kW Max.). An optional cooling coil cabinet is offered with up to 2 furnaces (800 MBH Max.). Both "Standard" and "High CFM" blower arrangements may also include a down-turn Supply Air Plenum, Outside Air Intake Hood and a Roof Curb. All arrangements are rail mounted.

Furnace types are also divided into two classifications "Standard Temperature Rise" and "High Temperature Rise" with Natural and Power vented models and Left or Right Hand access (see "Unit Type" [UT], "Furnace Type" [FT] model number digits 1,2 and 5). Standard Temperature rise units have a lower pressure drop across the heat exchanger allowing higher air flow capacities and an 80% efficiency rating with ΔT of 20-60°F (11 - 33°C). High Temperature Rise units are configured for higher temperature rise and have a higher pressure drop across the furnace section of the unit with ΔT of 60-90°F (33 - 50°C). The High Temperature Rise type furnace is only available in a single furnace package and has an efficiency rating of 80% on capacities 10-25. High Temperature Rise unit capacities 30-40 have a 79% efficiency rating and are not available in California.

In addition to a versatile array of mechanical features Sterling Engineered Products Rooftop Units also offer a wide variety of factory installed control options. Control components are located in the main electrical cabinet. The main electrical cabinet is located out of the air stream as part of the blower transition, between the blower cabinet and the first furnace (or supply plenum if no furnace) for both Standard and High CFM units. The standard electrical control scheme consists of a solid state fan time delay, two pre-wired relay sockets for fan on and damper open functions mounted on the unit's main connection board, a solid state gas ignition system and room or duct thermostats. The units are also equipped with a blower door safety interlock, a 24 VAC circuit breaker, a high temperature limit switch in each furnace section and a reverse air flow switch located in the blower cabinet as standard equipment.

Gas control options range from single stage to six stages of fire, Mechanical or Electronic Modulation and DDC (Direct Digital Control) ready packages (see "Gas Control" [GC] model number digit 10). Air control options offer a similar range of control features from manual dampers to modulating motorized dampers that may include mixed air, dry bulb, pressure sensing, enthalpy control, DDC interface or ASHRAE Cycle control arrangements (see "Air Control" [AC] model number digit 15).

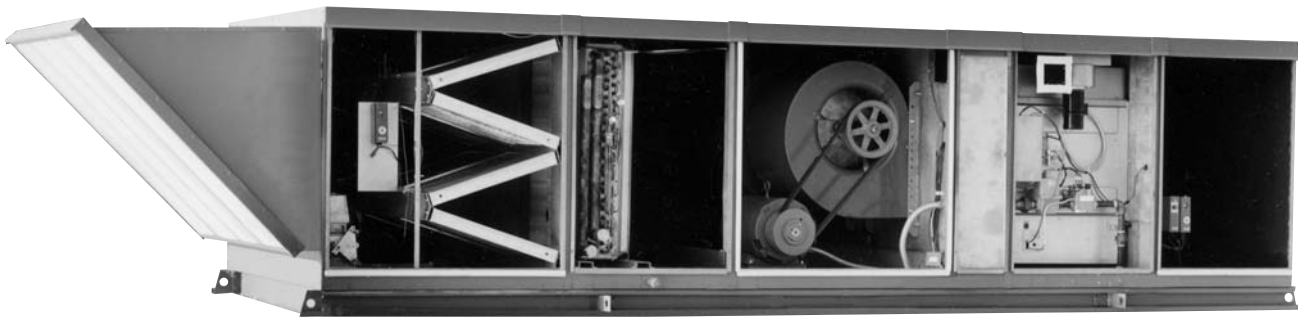

Features and Benefits

- AGA and CGA Certified Duct Furnaces.
- ETL and CSA UL-1995 Certified Packaged Units.
- FM (Factory Mutual) Compliant.
- Heating Capacities from 100 MBH - 1,200 MBH. (29.3 kW - 351.4 kW)
- Natural and Power Vented Furnaces.
- 80% Efficient Standard Temperature Rise Furnace.
- Standard Temperature Rise 20-60°F (11-33°C) per Furnace.
- High Temperature Rise 60-90°F (33-50°C) single Furnace.
- CFM Ranges from 800 - 14,000 CFM (0.4 — 6.6 Cu. m/s).
- Motor Sizes up to 15 Horse Power (EPACT compliant).
- Standard ODP Motors; with Premium Efficiency, Totally Enclosed and 2 speed optional.
- Standard Right Side Service Access, Left Optional.
- Draw-thru Heating or Cooling Coil Cabinet with Stainless Steel Drip Pan.
- Evaporative Cooling with standard 8 or optional 12 in. media (203 or 305 mm).
- Standard Insulated Roof Curbs (Optional Uninsulated Roof Curbs Available).
- Vibration Isolation Roof Curbs.
- Adapter Roof Curbs.
- Standard 18 ga. Cabinets, Painted Sterling Gray.
- Standard 20 ga. Aluminized Steel Heat Exchanger (Stainless Steel Optional).
- Standard 1" in. Washable Filters.
- Standard Single Stage Combination Gas Valve.
- Standard High Temperature Limit (each Furnace).
- Standard Blower Door Safety Interlock Switch.
- Standard Reverse Air Flow Safety Switch.
- Standard 24 Volt Circuit Breaker.
- Standard Printed Circuit Main Connection Board.
- Wiring Harnesses with Stamped Wire Numbers.
- Solid State Automatic Pilot Ignition Control.
- Solid State Fan Time Delay.
- Over 40 Standard Control Packages.

Sterling Specifier

The STERLING SPECIFIER is a Microsoft Windows® based computer program developed to assist the HVAC industry in design and application of Sterling rooftop equipment.

This automated selection program is capable of selecting a rooftop unit by direct model number input or design data (ie: Required output, Air Flow or Temperature Rise.)

The STERLING SPECIFIER is designed to produce and print model number specific certification and specification sheets that include customer information, submittal sheet attachment listing and model number description. These files are in standard text format for use with any word processing program.

To receive your copy of the STERLING SPECIFIER contact your nearest Sterling Representative or contact our Customer Service Department at 413-564-5540, FAX: 413-562-5311, or www.sterlinghvac.com



Engineered Products Model Number Description

GENERAL INFORMATION

Digit	E	X	X	1	2	3	4	5	6	7	8	9	10	11	12	13	14	15	16	+
Item	Prefix			UT	CA	FT	FM	RA	CO	GT	GC	SV	MT	MS	AI	AC	AS			

(Internal Use Only)

1, 2 - Unit Type [UT]

- RT - Natural Vent Rooftop
- PV - Power Vented Rooftop
- AH - Air Handler
- EV - Evaporative Cooler Only

3, 4 - Capacity [CA]

Single Furnace

- 10 - 100,000 BTU/HR
- 15 - 150,000 BTU/HR
- 20 - 200,000 BTU/HR
- 25 - 250,000 BTU/HR
- 30 - 300,000 BTU/HR
- 35 - 350,000 BTU/HR
- 40 - 400,000 BTU/HR

Double Furnace

- 50 - 500,000 BTU/HR
- 60 - 600,000 BTU/HR
- 70 - 700,000 BTU/HR
- 80 - 800,000 BTU/HR

Triple Furnace

- 12 - 1,200,000 BTU/HR

5 - Furnace Type/Access Side [FT]

- A - Standard Temperature Rise (20-60 F Deg.), Right Side Access
- B - Standard Temperature Rise (20-60 F Deg.), Left Side Access
- C - High Temperature Rise (60-90 F Deg.), Right Side Access
- D - High Temperature Rise (60-90 F Deg.), Left Side Access
- O - None
- Z - Other

6 - Furnace Construction Material [FM]

- 1 - Aluminized Steel
- 2 - 409 Stainless Steel (First Furnace Only)
- 3 - 409 Stainless Steel (All Furnace Sections)
- 4 - 321 Stainless Steel (First Furnace Only)
- 5 - 321 Stainless Steel (All Furnace Sections)
- 6 - 409 Stainless Steel Package (First Furnace Only)
- 7 - 409 Stainless Steel Package (All Furnace Sections)
- 8 - 321 Stainless Steel Package (First Furnace Only)
- 9 - 321 Stainless Steel Package (All Furnace Sections)
- O - None
- Z - Other

7 - Rooftop Arrangement (B-L assumes furnace section(s)) [RA]

- | | |
|--|---|
| A - Duct Furnace | M - Air Handler (Standard) |
| B - Blower (Standard) | N - Air Handler (Standard) / Plenum |
| C - Blower (Standard) / Plenum | P - Air Handler (Standard) / Evap. Cooling |
| D - Blower (Standard) / Evap. Cooling | R - Air Handler (Standard) / Evap. Cooling / Plenum |
| E - Blower (Standard) / Evap. Cooling / Plenum | S - Air Handler (High CFM) |
| G - Blower (High CFM) | T - Air Handler (High CFM) / Plenum |
| J - Blower (High CFM) / Plenum | U - Air Handler (High CFM) / Coil Cabinet |
| K - Blower (High CFM) / Coil Cabinet | W - Air Handler (High CFM) / Coil Cabinet / Plenum |
| L - Blower (High CFM) / Coil Cabinet / Plenum | O - None |
| | Z - Other |

8 - Coil Options [CO]

- | | |
|-----------------------------------|-------------------------------|
| A - DX Coil, 4 Row Single Circuit | E - Chilled Water Coil, 4 Row |
| B - DX Coil, 4 Row Dual Circuit | G - Chilled Water Coil, 6 Row |
| C - DX Coil, 6 Row Single Circuit | O - None |
| D - DX Coil, 6 Row Dual Circuit | Z - Other |

9 - Gas Type [GT]

- 1 - Natural Gas
- 2 - Propane Gas (LP)
- 3 - Natural Gas w/100% Lockout
- O - None

10 - Gas Control [GC]

- A - Single Stage Gas (Standard)
- B - Two Stage Gas
- C - Mechanical Modulation (60-100)
- D - Mechanical Modulation (75-200)
- F - Mechanical Modulation w/Bypass & Limit (60-100)
- G - Mechanical Modulation w/Bypass (75-200)
- H - Electronic Modulation w/Room Sensing
- J - Electronic Modulation w/Duct Sensing
- K - Electronic Modulation w/Duct Sensing & Ovrd. Stat
- L - Electronic Modulation w/External 4-20 mA Input (Furnace One)
- M - Electronic Modulation w/External 4-20 mA Input (All Furnaces)
- N - Electronic Modulation w/External 0-10 VDC Input (Furnace One)
- P - Electronic Modulation w/External 0-10 VDC Input (All Furnaces)
- R - Two Stage Remote Temperature Control w/Duct Sensor
- S - Three Stage Remote Temperature Control w/Duct Sensor
- T - Four Stage Remote Temperature Control w/Duct Sensor
- U - S-350 2 Stage Modular Electronic Control System
- W - S-350 3 Stage Modular Electronic Control System
- X - S-350 4 Stage Modular Electronic Control System
- Y - S-350 6 Stage Modular Electronic Control System
- O - None
- Z - Other

11 - Supply Voltage [SV]

- | | |
|--------------|--------------|
| 1 - 115/1/60 | 5 - 230/3/60 |
| 2 - 208/1/60 | 6 - 460/3/60 |
| 3 - 230/1/60 | 7 - 575/3/60 |
| 4 - 208/3/60 | O - None |
| | Z - Other |

12 - Motor Type [MT]

- 1 - Open Drip Proof (Standard)
- 2 - Totally Enclosed
- 3 - Premium Efficiency, Open Drip Proof
- 4 - Premium Efficiency, Totally Enclosed
- 5 - Two Speed One Winding, Open Drip Proof
- 6 - Two Speed Two Winding, Open Drip Proof
- O - None
- Z - Other

13 - Motor Sizes [MS]

- | | |
|--------------------------------|----------------------------------|
| A - 1/2 HP. w/Contactor | M - 1-1/2 HP. w/Magnetic Starter |
| B - 3/4 HP. w/Contactor | N - 2 HP. w/Magnetic Starter |
| C - 1 HP. w/Contactor | P - 3 HP. w/Magnetic Starter |
| D - 1-1/2 HP. w/Contactor | R - 5 HP. w/Magnetic Starter |
| E - 2 HP. w/Contactor | S - 7-1/2 HP. w/Magnetic Starter |
| G - 3 HP. w/Contactor | T - 10 HP. w/Magnetic Starter |
| H - 5 HP. w/Contactor | U - 15 HP. w/Magnetic Starter |
| J - 1/2 HP. w/Magnetic Starter | O - None |
| K - 3/4 HP. w/Magnetic Starter | Z - Other |
| L - 1 HP. w/Magnetic Starter | |

14 - Air Inlet Configuration [AI]

- | | |
|---|--|
| 1 - Outside Air (OA) (Horiz. Inlet) | 4 - Outside Air and Return Air (OA/RA) |
| 2 - Outside Air w/Air Hood (Horiz. Inlet) | 5 - Outside and Return Air w/Air Hood |
| 3 - Bottom Return Air (RA) | O - None |
| | Z - Other |

15 - Air Control & Damper Arrangement [AC]

- A - Outside Air 2 Pos. Motor / Spring Return
 - B - Return Air 2 Pos. Motor / Spring Return
 - C - OA/RA 2 Pos. / Spring Return
 - D - OA/RA Mod. Mtr. w/Mixed Air Control / Min. Pot.
 - E - OA/RA Mod. Mtr. w/Mixed Air Control / Min. Pot. / SR
 - G - OA/RA Mod. Mtr. w/Mixed Air Control
 - H - OA/RA Mod. Mtr. w/Mixed Air Control / SR
 - J - OA/RA Mod. Mtr. w/Min. Pot.
 - K - OA/RA Mod. Mtr. w/Min. Pot. / SR
 - L - OA/RA Mod. Mtr. w/Dry Bulb / Mixed Air Control / Min. Pot.
 - M - OA/RA Mod. Mtr. w/Dry Bulb / Mixed Air Control / Min. Pot. /SR
 - N - OA/RA Mod. Mtr. w/Enthalpy Controlled Economizer / SR
 - P - OA/RA Mod. Mtr. w/Pressure Control (Space Pressure)
 - R - OA/RA Mod. Mtr. w/S-350-P Proportional Mixed Air Control / SR
 - S - OA/RA Mod. Mtr. w/0-10 VDC & 4-20 mA Analog Input (External Input)
 - T - OA/RA Mod. Mtr. w/0-10 VDC & 4-20 mA Analog Input / SR (External Input)
 - U - ASHRAE Cycle I (OA/RA 2 Pos. Mtr. w/Warm-up Stat / SR)
 - W - ASHRAE Cycle II (OA/RA Mod. Mtr. w/Warm-up Stat / Mixed Air / Min. Pot. / SR)
 - X - ASHRAE Cycle III (OA/RA Mod. Mtr. w/Warm-up Stat / Mixed Air / SR)
 - Y - Manual Dampers
 - O - None
 - Z - Other
- MOD = Modulating Damper Motor
OA = Outside Air RA = Return Air SR = Spring Return

16 - Accessories [AS]

- | | |
|---------------------------------------|---|
| A1 - Moisture Eliminators | G1 - Thermostat - T87F w/Subbase |
| A2 - Horizontal Return | G2 - Thermostat - T87F w/Subbase & Guard |
| A3 - Low Leak Damper | G3 - Thermostat - T834H w/Subbase (Sterling Stat) |
| A5 - Furnace Drip Pan, 409 Stainless | G4 - Thermostat - T7300 - 7 Day Programmable |
| A6 - High Altitude Unit | G5 - Thermostat - T874 (Two Stage) |
| A7 - High Pressure Regulator | G6 - Locking Thermostat Cover |
| A8 - Input De-rate | |
| B1 - Filters - 1" WA (Standard) | H1 - Return Firestat |
| B2 - Filters - 2" WA | H2 - Supply Firestat |
| B3 - Filters - 2" TA | H3 - Time Delay Freezestat |
| B4 - Filters - 1" 30% | H4 - Ambient Lockout |
| B5 - Filters - 2" 30% | |
| C1 - Evap. Cooler - Fill & Drain Kit | J1 - Interlock Relay - 24V Coil DPDT 10A, Plug-in |
| C2 - Evap. Cooler - 12" CELdek® Media | J2 - Interlock Relay - 24/115V Coil SPDT 10A |
| C3 - Evap. Cooler - Freezestat | J3 - Interlock Relay - 24/115/230V Coil DPDT 10A |
| C4 - 8" GLASdek® Media | J4 - Interlock Relay - 24V Coil 4PDT 10A |
| C5 - 12" GLASdek® Media | |
| D1 - Time Clock - 7 Day | K1 - Manual Reset High Limit Switch |
| D2 - Time Clock - 24 Hour | K2 - High / Low Gas Pressure Limit Switches |
| E1 - Clogged Filter Switch | K3 - Status Lamp (Elec. Cabinet) |
| E2 - G.F.I. Convenience Outlet 115VAC | K4 - Fan Time Delay (Arrangement A Only) |
| E3 - Remote Control Panel | K5 - Air Flow Prove Switch |
| E4 - Manual Blower Switch | |
| F1 - Ductstat - One Stage | L1 - 30 Amp, Fused Disconnect Switch |
| F2 - Ductstat - Two Stage | L2 - 30 Amp, Non Fused Disconnect Switch |
| | L3 - 60 Amp, Fused Disconnect Switch |
| | L4 - 60 Amp, Non Fused Disconnect Switch |
| | N1 - Hinged Access Door(s) |
| | N2 - Through the Base Utility Penetration |
| | N3 - Service Convenience Package |
| | *N6 - Doublewall Construction |
| | O - None |
| | Z1 - Other (Specify) |

* Note: N6 includes N1

Table of Contents

General Information	2
Model Number Description	4
Outdoor Duct Furnaces	6
Performance Data	7-9
Dimensional Data	10, 11
Packaged Rooftop Arrangements	12
Performance Data	14-25
Dimensional Data	26-34
Cooling Coil Options [CO]	35
Performance Data	36-39
Gas Type [GT] and Gas Control [GC]	40, 41
Voltage Supply [SV], Motor Type [MT] and Motor Size [MS]	42
Air Inlet Configuration [AI]	43
Air Inlet Control and Damper Arrangement [AC]	43, 44
Accessories [AS]	45-48
Air Handler and Evaporative Cooler Selection	49
Air Handler	50
Performance Data	51, 52
Dimensional Data	53-56
Evaporative Cooling Unit	57-59
Roof Curb Kits	60-63
Specifications Guide	64-69
Unit Selection Procedure	70
Cooling Coil Selection Procedure	71
Unit Net and Ship Weights	72, 73
Roof Curb Kits - Ship Weights	74
Motor Electrical Data	75
Warranty	76

Engineered Products Outdoor Duct Furnaces

Natural [RT] and Power [PV] Vent



Unit Type [UT] Model Digits 1,2

Capacity [CA] Model Digits 3,4

Furnace Type [FT] Model Digit 5

Furnace Material [FM] Model Digit 6

Rooftop Arrangement [RA] Model Digit 7

Sterling Engineered Products Rooftop Duct Furnaces are AGA and CGA certified and FM (Factory Mutual) compliant. Duct Furnaces are available as Natural or Power Vented Units. Sizes range from 100 MBH to 400 MBH (29.3 kW to 117.1 kW) per furnace with double and triple in series configurations available, for a capacity range of 100 MBH to 1,200 MBH (29.3 to 351.4 kW). All Sterling Rooftop Duct Furnaces are designed with ease of service in mind and feature quick opening access side panels right or left side, slide-out burner drawer, terminal block connection, solid state automatic pilot ignition, combination gas valve and automatic reset safety limits. Duct furnaces may be ordered to operate with Natural or LP gas (Gas Type [GT] Model digit 9) and are standard for altitudes at 0 to 2,000 feet (610m). Units are also available for higher elevations. Specify when ordering if unit is above 2,000 feet (610m).

The Natural Vent units (Unit Type [UT] "RT") utilize an innovative vent cap that vents products of combustion through the center flue and out the top of the vent cap. Fresh air for combustion is drawn through a protective grill at the base of the cap. This balance of combustion air and flue gas discharge ensure trouble free operation under all wind conditions. The vent cap is shipped separately for on-site installation and should not be altered in any way.

Power Vented units (Unit Type [UT] "PV") eliminate the need for a vent cap, therefore lowering the overall height of the unit. A power ventor assembly, consisting of a 1/20 Hp. blower motor, is utilized to mechanically exhaust flue gases. The louvered intake and exhaust ports are built into a one piece access door. Power venting is required, along with the optional 100% lock-out ignition (Gas Type [GT] "3"), for IRI (Industrial Risk Insurers) compliance.

Sterling Engineered Products Rooftop Duct Furnaces are available in two types: Standard Temperature Rise type "A" and "B", and High Temperature Rise type "C" and "D" (Furnace Type [FT] Model digit 5). Standard Temperature rise units have a lower pressure drop across the heat exchanger, allowing higher air flow capacities and an 80% efficiency rating with ΔT of 20-60°F (11-33°C) per furnace. Standard Temperature Rise type furnaces are available in single, double and triple series capacities (Capacity [CA] Model digits 3,4 "10-12"). High Temperature rise units are configured for higher temperature rise and have a higher pressure drop across the furnace section of the unit and an 80%

efficiency rating (79% on capacities 30, 35 and 40) with ΔT of 60-90°F (33-50°C). The High Temperature Rise type furnace is only available in single furnace capacities (Capacity [CA] Model digits 3,4 "10-40"). The High Temperature Rise type furnace capacities 30, 35 and 40 are not available in California. The maximum discharge air temperature for all duct furnaces is 150°F (66°C).

All Sterling Engineered Products Rooftop Duct Furnaces are constructed with aluminized steel heat exchangers, flue collectors and burners. Optional 409 or 321 stainless steel heat exchanger, 409 stainless steel burner, and 409 stainless steel flue collector are also available (Furnace Material [FM] Model Digit 6). **An optional 409 or 321 Stainless Steel heat exchanger is recommended for the following applications:**

1. When the combined temperature of outside and return air is below 40°F (4.4°C).
2. Whenever there is an evaporative cooler or cooling coil upstream of the furnace section(s).

Unit Type [UT] Digit 1,2

RT - Natural Vent

PV - Power Vent

AH - Air Handler

EV - Evaporative Cooler

Capacity [CA] Digit 3,4

Single Furnace* Double Furnace

10 - 100 MBH 50 - 500 MBH

15 - 150 MBH 60 - 600 MBH

20 - 200 MBH 70 - 700 MBH

25 - 250 MBH 80 - 800 MBH

30 - 300 MBH

35 - 350 MBH Triple Furnace

40 - 400 MBH 12 - 1,200 MBH

** Single furnace capacities [CA 10/40] available only on rooftop arrangements [RA] B, C, D, E, K & L; single furnace capacities [CA 20/40] available on roof top arrangements [RA] G & J.*

Furnace Type [FT] Digit 5

A - Standard Temperature Rise, Right Side Access

B - Standard Temperature Rise, Left Side Access

C - High Temperature Rise, Right Access

D - High Temperature Rise, Left Access

Furnace Material [FM] Digit 6

1 - Aluminized Steel (STANDARD)

2 - 409 Stainless Steel Heat Exchanger (First Furnace Only)

3 - 409 Stainless Steel Heat Exchanger (All Furnace Sections)

4 - 321 Stainless Steel Heat Exchanger (First Furnace Only)

5 - 321 Stainless Steel Heat Exchanger (All Furnace Sections)

6 - 409 Stainless Steel Package, Heat Exchanger, Burners Flue Collector (First Furnace Only)

7 - 409 Stainless Steel Package, Heat Exchanger, Burners Flue Collector (All Furnace Sections)

8 - 321 Stainless Steel Package, Heat Exchanger, 409 Burners, Flue Collector (First Furnace Only)

9 - 321 Stainless Steel Package, Heat Exchanger, 409 Burners, Flue Collector (All Furnace Sections)

Outdoor Duct Furnace Performance Data – Table 1

Unit Type RT or PV, Capacity 10-12, Furnace Type A,B/C,D, Rooftop Arrangement “A”

Capacity [CA] Furnace Type [FT] (kW)	INPUT RATING BTU/Hr (kW)	OUTPUT RATING BTU/Hr	EFF. % MIN.	CFM (cu. m/s) MIN.	ΔT F° (C°) MAX.	Press. Drop In. of Water (kPa)	CFM (cu. m/s) MAX.	ΔT F° (C°) MIN.	Press. Drop In. of Water (kPa)	Nat.Gas Inlet in.	L.P. Gas Inlet in.
10 A/B	100,000 (29.3)	80,000 (23.4)	80	1,235 (0.583)	60 (33)	0.15 (0.04)	3,704 (1.748)	20 (11)	1.10 (0.27)	1/2	1/2
15 A/B	150,000 (43.9)	120,000 (35.1)	80	1,852 (0.874)	60 (33)	0.15 (0.04)	5,556 (2.622)	20 (11)	1.00 (0.25)	1/2	1/2
20 A/B	200,000 (58.6)	160,000 (46.9)	80	2,469 (1.165)	60 (33)	0.15 (0.04)	7,407 (3.496)	20 (11)	1.05 (0.26)	1/2	1/2
25 A/B	250,000 (73.2)	200,000 (58.6)	80	3,086 (1.457)	60 (33)	0.15 (0.04)	9,259 (4.370)	20 (11)	1.08 (0.27)	3/4	1/2 or 3/4
30 A/B	300,000 (87.8)	240,000 (70.3)	80	3,704 (1.748)	60 (33)	0.15 (0.04)	11,111 (5.244)	20 (11)	1.10 (0.27)	3/4	1/2 or 3/4
35 A/B	350,000 (102.5)	280,000 (82.0)	80	4,321 (2.040)	60 (33)	0.15 (0.04)	12,963 (6.119)	20 (11)	1.11 (0.28)	3/4	1/2 or 3/4
40 A/B	400,000 (117.1)	320,000 (93.7)	80	4,938 (2.331)	60 (33)	0.15 (0.04)	14,815 (6.993)	20 (11)	1.12 (0.28)	3/4	1/2 or 3/4
50 A/B	500,000 (146.4)	400,000 (117.1)	80	3,086 (1.457)	120 (67)	0.30 (0.07)	9,269 (4.375)	40 (22)	2.16 (0.54)	3/4	1/2 or 3/4
60 A/B	600,000 (175.7)	480,000 (140.6)	80	3,704 (1.748)	120 (67)	0.30 (0.07)	11,111 (5.244)	40 (22)	2.20 (0.55)	3/4	1/2 or 3/4
70 A/B	700,000 (205.0)	560,000 (164.0)	80	4,321 (2.040)	120 (67)	0.30 (0.07)	12,963 (6.119)	40 (22)	2.22 (0.55)	3/4	1/2 or 3/4
80 A/B	800,000 (234.3)	640,000 (187.4)	80	4,938 (2.331)	120 (67)	0.30 (0.07)	14,815 (6.993)	40 (22)	2.24 (0.56)	3/4	1/2 or 3/4
12 A/B	1,200,000 (351.4)	960,000 (281.1)	80	4,938 (2.331)	180 (100)	0.45 (0.11)	14,815 (6.993)	60 (33)	3.36 (0.84)	3/4	1/2 or 3/4
10 C/D	100,000 (29.3)	80,000 (23.4)	80	823 (0.388)	90 (50)	0.10 (0.02)	2,469 (1.165)	30 (17)	0.88 (0.22)	1/2	1/2
15 C/D	150,000 (43.9)	120,000 (35.1)	80	1,219 (0.575)	90 (50)	0.10 (0.02)	3,657 (1.726)	30 (17)	0.78 (0.19)	1/2	1/2
20 C/D	200,000 (58.6)	160,000 (46.9)	80	1,626 (0.767)	90 (50)	0.10 (0.02)	4,876 (2.301)	30 (17)	0.81 (0.20)	1/2	1/2
25 C/D	250,000 (73.2)	200,000 (58.6)	80	2,032 (0.959)	90 (50)	0.10 (0.02)	6,096 (2.877)	30 (17)	0.85 (0.21)	3/4	1/2 or 3/4
30 C/D	300,000 (87.8)	237,000 (69.4)	79	2,438 (1.151)	90 (50)	0.10 (0.02)	7,315 (3.453)	30 (17)	0.86 (0.21)	3/4	1/2 or 3/4
35 C/D	350,000 (102.5)	276,500 (81.0)	79	2,845 (1.343)	90 (50)	0.10 (0.02)	8,534 (4.028)	30 (17)	0.87 (0.22)	3/4	1/2 or 3/4
40 C/D	400,000 (117.1)	316,000 (92.5)	79	3,251 (1.534)	90 (50)	0.10 (0.02)	9,753 (4.603)	30 (17)	0.88 (0.22)	3/4	1/2 or 3/4

Ratings shown are for unit installations at elevations between 0 and 2000 ft. (610m).

For unit installations in U.S.A. above 2000 ft. (610m), the unit input must be derated by 4% for each 1000 ft. (305m) above sea level; refer to local codes, or in the absence of local codes, refer to the National Fuel Gas Code, ANSI Standard Z223.1-1996 (N.E.P.A. No. 54), or the latest edition of.

For installations in Canada, any references to deration at altitudes in excess of 2000 ft. (610m) are to be ignored. At altitudes of 2000 to 4500 ft. (610 to 1372m), the unit must be derated to 90% of the normal altitude rating, and be so marked in accordance with the C.G.A. certification.



“RT” Natural Vent Duct Furnace



“PV” Power Vent Duct Furnace



OUTDOOR DUCT FURNACE

Duct Furnace Performance – Chart 1 Standard Temperature Rise

Furnace Type - (A,B) 20 – 60° F Temperature Rise

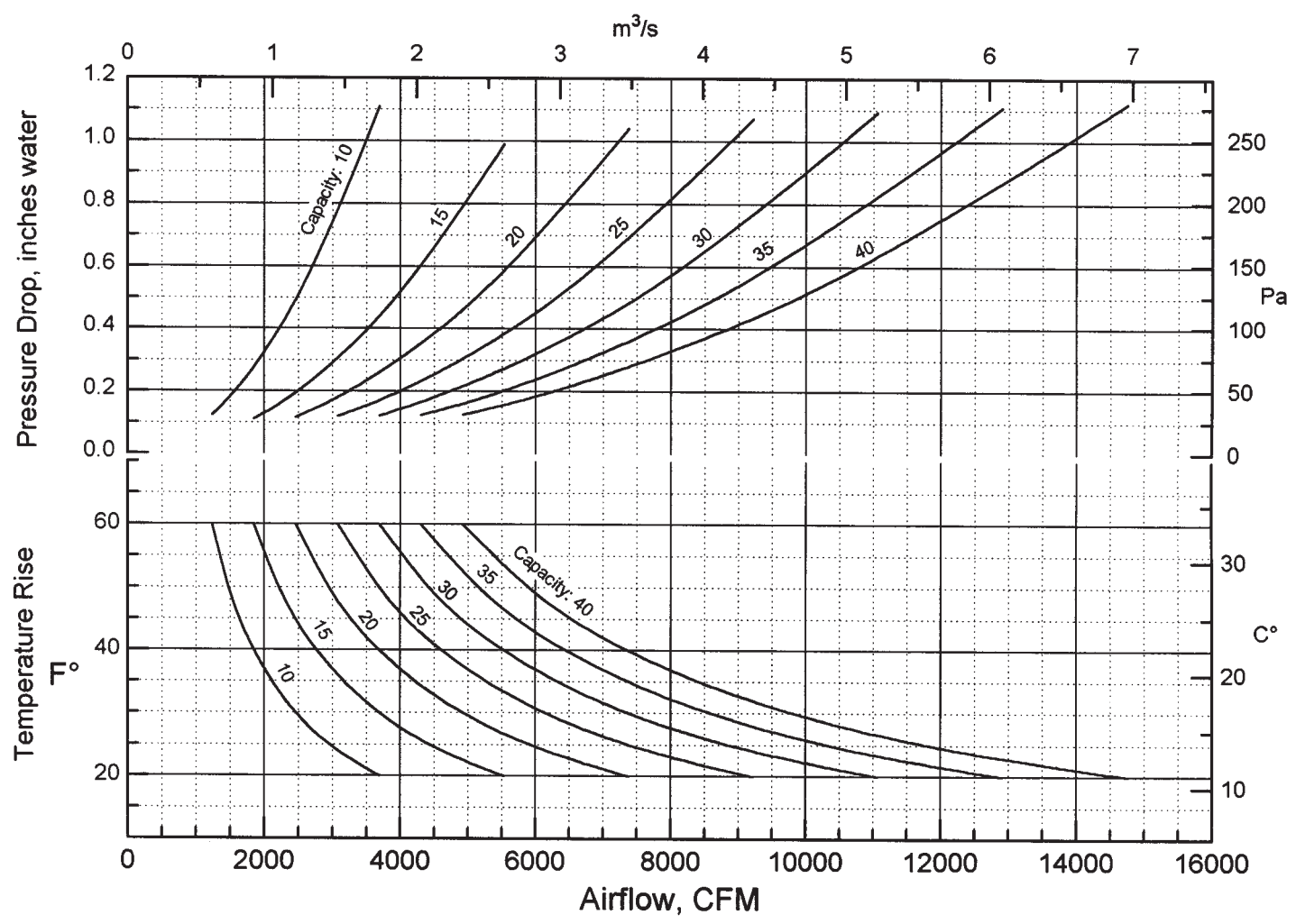

Duct Furnace Performance – Chart 2

High Temperature Rise

Furnace Type - (C,D) 60 – 90° F Temperature Rise

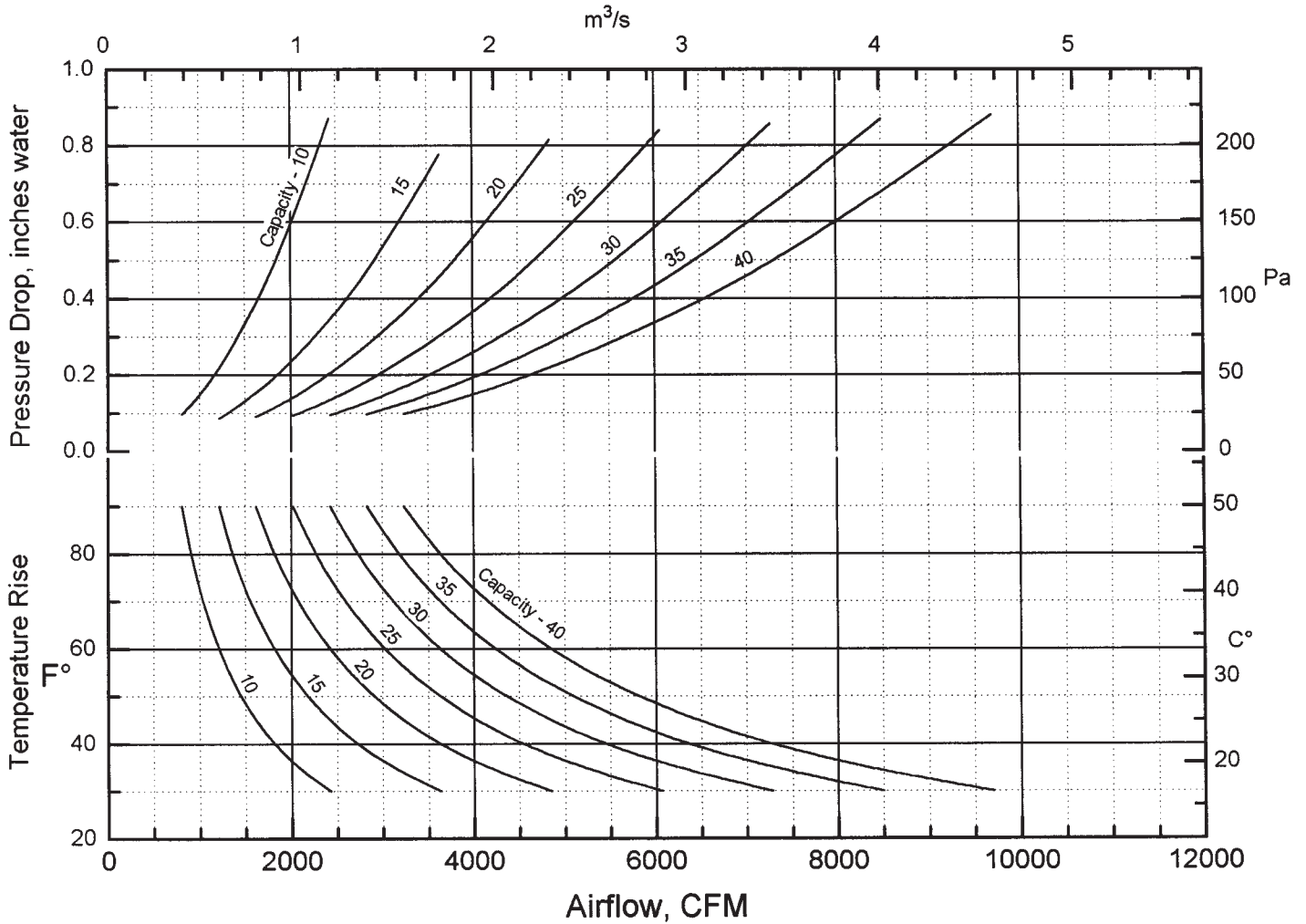

OUTDOOR DUCT FURNACE

Dimensional Data – Outdoor Duct Furnaces

OUTDOOR DUCT FURNACE

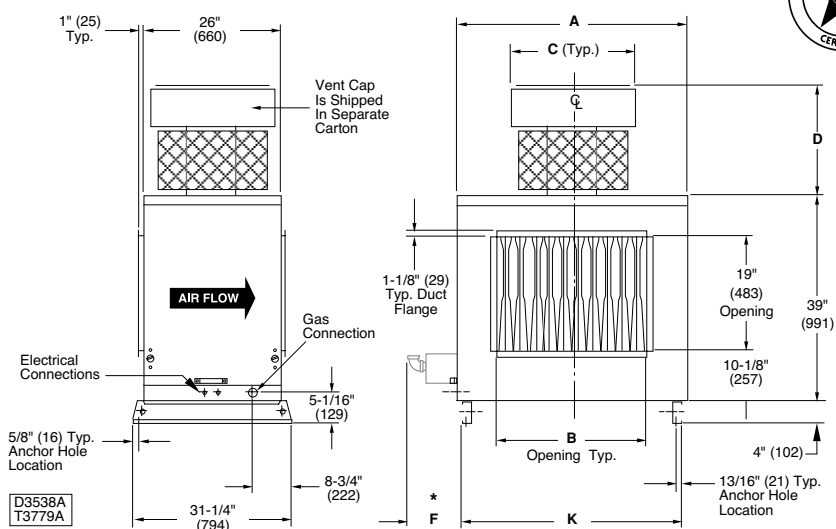

Rooftop Arrangement [RA] "A" - Capacities [CA] 10 - 40
QVRT - 100/400 MBH Unit Sizes

Capacity (CA)	A	B	C	D		*F	K	GAS INLET	
				AGA	CGA			NAT	LP
10	32- 7/8 (835)	15- 9/16 (395)	12 (305)	11 (279)	20-11/16 (525)	19- 3/8 (492)	30- 3/16 (767)	1/2	1/2
15	32- 7/8 (835)	18- 5/16 (465)	21- 1/2 (546)	16 (406)	25- 3/16 (640)	23- 1/2 (597)	30- 3/16 (767)	1/2	1/2
20	43- 7/8 (1114)	23-13/16 (605)	23- 1/2 (597)	16 (406)	25- 3/16 (640)	26- 1/4 (667)	41- 3/16 (1046)	1/2	1/2
25/50	43- 7/8 (1114)	29- 5/16 (745)	23- 1/2 (597)	16 (406)	25- 3/16 (640)	34- 1/2 (876)	41- 3/16 (1046)	3/4	1/2 OR 3/4
30/60	54- 7/8 (1394)	34-13/16 (884)	26 (660)	17- 1/2 (445)	26-11/16 (678)	37- 1/4 (946)	52- 3/16 (1326)	3/4	1/2 OR 3/4
35/70	54- 7/8 (1394)	40- 5/16 (1024)	26 (660)	17- 1/2 (445)	26-11/16 (678)	45- 1/2 (1156)	52- 3/16 (1326)	3/4	1/2 OR 3/4
40/80/12	60- 3/8 (1534)	45-13/16 (1164)	26 (660)	17- 1/2 (445)	26-11/16 (678)	51 (1295)	57-11/16 (1465)	3/4	1/2 OR 3/4

NOTES:
Dimensions are in inches. Dimensions in parenthesis are in millimeters.
* "F" Dimension is the recommended clearance to service the burner drawer(s).

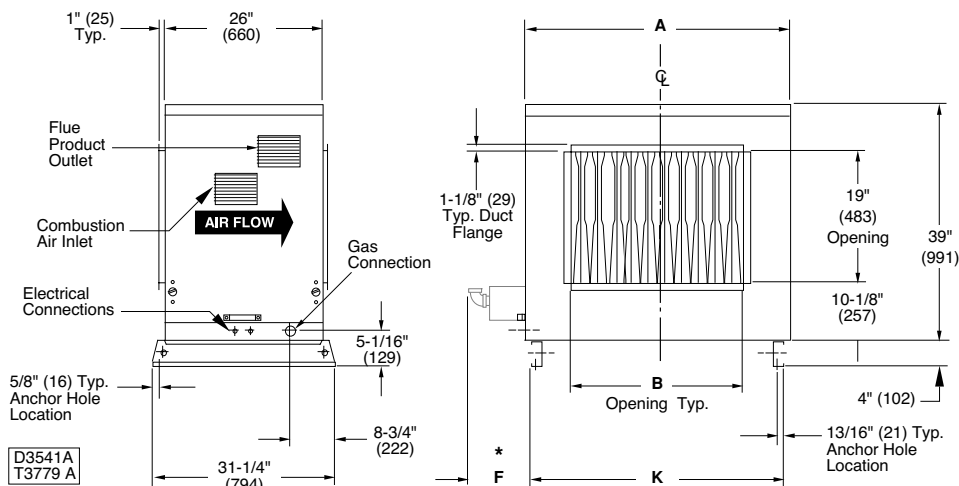

Rooftop Arrangement [RA] "A" - Capacities [CA] 10 - 40
QVPV - 100/400 MBH Unit Sizes

Dimensional Data – Outdoor Duct Furnaces

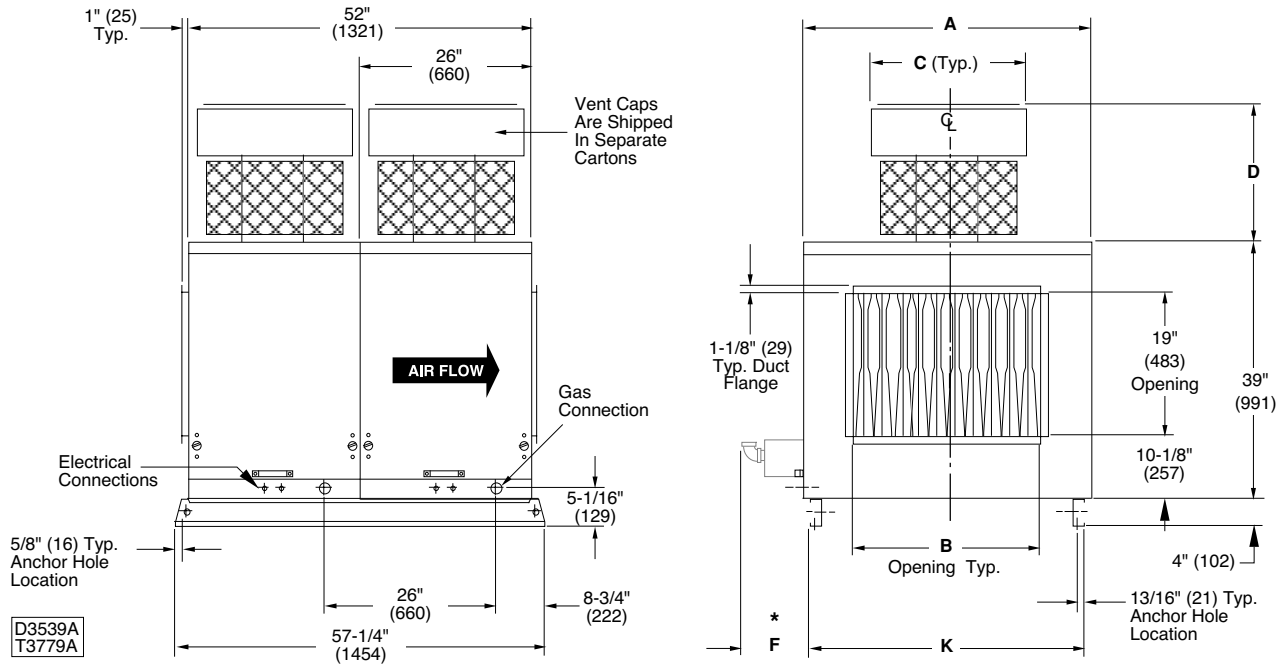

Rooftop Arrangement [RA] "A"
Capacities [CA] 50 - 80 Unit Sizes

Refer to page 10 for tabulated dimensional data.

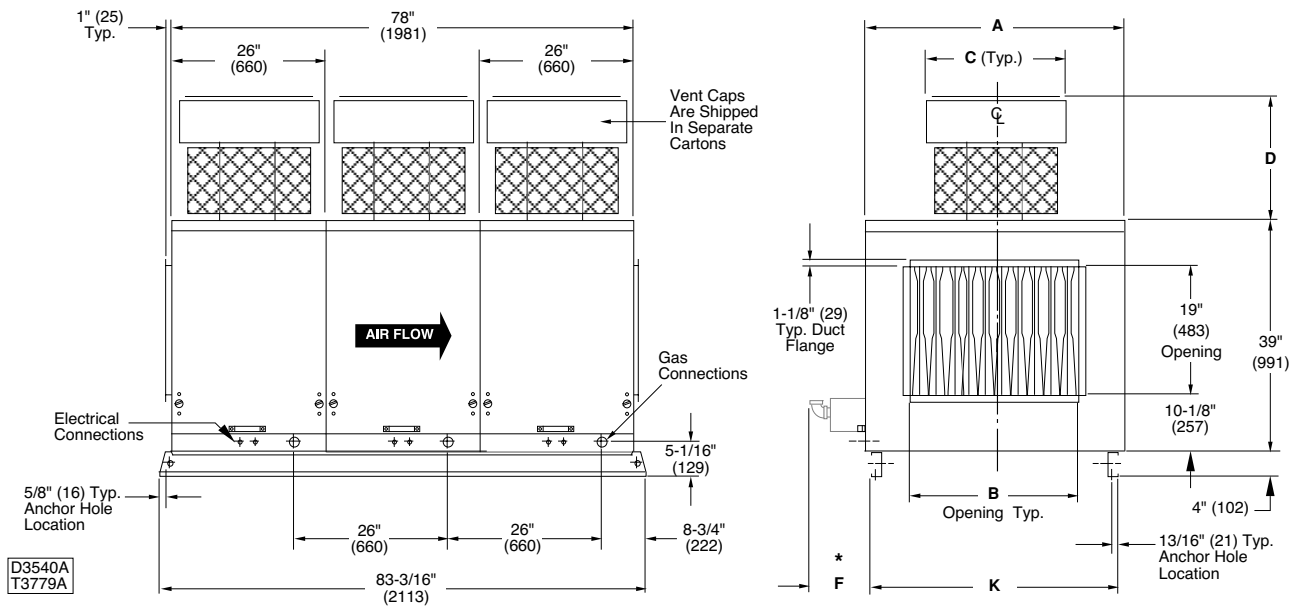

Rooftop Arrangement [RA] "A"
Capacity [CA] 12 Unit Sizes

Refer to page 10 for tabulated dimensional data.

These arrangements shown are for Natural Vent "RT" Units.
Contact Customer Service for Power Vent "PV" Unit Submittals.



Packaged Rooftop Arrangements Heating & Cooling Units

Rooftop Arrangement [RA] Model Digit 7



Sterling Packaged Rooftop Units are ETL and CSA certified to UL-1995 standard for heating, cooling and ventilating equipment. Units are available in one of 17 standard arrangements (Rooftop Arrangements [RA], Model digit 7). Packaged heating and cooling units are suitable for commercial, institutional and industrial applications where external system pressure losses are as high as 2 in. W.C. (0.50 kPa).

Rooftop Arrangements are divided into two classifications "Standard" and "High-CFM" Blower types. The "Standard" blower units (Rooftop Arrangement [RA] "B-E") have a CFM range of 800-8,500 (0.4 - 4.0 m³/s). The Standard blower arrangement consists of a blower cabinet that houses dampers, filters and blower(s) in one cabinet; an optional Evaporative Cooling Unit with standard 8 or optional 12 in. (203 or 305 mm) media; and up to 2 Duct Furnaces (800 MBH Max.) (234.3 kW max) may also be included.

The "High-CFM" Blower Units (Rooftop Arrangement [RA] "G & J") have a range of 2,000 - 14,000 CFM (0.9 - 6.6 m³/s). These High-CFM Blower units utilize a separate Damper/Filter cabinet with a "V" bank filter arrangement, a Blower Cabinet and up to 3 Duct Furnaces (1,200 MBH Max.) (351.4 kW).

Rooftop Arrangements "K & L" utilize the same cabinetry as Rooftop Arrangements "G & J" plus an additional Cooling Coil Cabinet capable of up to 20 tons and a CFM range of 960 - 6,300 (0.4 - 3.0 m³/s). These utilize up to 2 duct furnaces (800 MBH) (234.3 kW) max. This coil cabinet may also be suitable for field installations of heating coils.

Both "Standard" and "High-CFM" blower arrangements may also include a downturn Supply Air Plenum, Outside Air Intake Hood with standard Bird

Screen or Optional Moisture Eliminators and a Roof Curb. All arrangements are rail mounted. We offer DX or Chilled Water type cooling coils.

For your safety and convenience, all Sterling Packaged Heating and Cooling Units include the following: a 24 Volt control circuit; Solid State Fan Time Delay; 24 Volt in line Circuit Breaker; Blower Door Interlock Switch; a Reverse Air Flow Switch (Return Firestat); Pre-wired Fan On and Exhaust Fan Interlock Relay Sockets; and a Printed Circuit Main Connection Board with Terminal Block Wiring. All wiring is processed at our factory as harness assemblies, and each wire is permanently stamped with its wire number.

All cabinets are constructed of rugged 18 ga. material and painted Sterling gray. The modular design of the cabinetry ensures reliability as well as serviceability with quick-release door latches, water-resistant sealed seams, insulated blower filter and plenum cabinets and down-rolled (hat type) rails mount tightly over the roof curb.

Rooftop Arrangements [RA] Digit 7

(B-L assumes furnace section(s))

- A - Duct Furnace
- B - Blower (STANDARD)
- C - Blower (STANDARD) / Plenum
- D - Blower (STANDARD) / Evap. Cooling
- E - Blower (STANDARD) / Evap. Cooling / Plenum
- G - Blower (HIGH-CFM)
- J - Blower (HIGH-CFM) / Plenum
- K - Blower (HIGH-CFM) / Coil Cabinet
- L - Blower (HIGH-CFM) / Coil Cabinet / Plenum



Standard Blower Unit



High-CFM Blower Unit

Packaged Rooftop Arrangement Reference

Unit Types [UT] RT or PV

*The maximum CFM for Rooftop Arrangements K and L is 6,300 (3.0 m³/s). A two speed motor may be utilized for non-cooling air flow up to 14,000 CFM (6.6 m³/2).

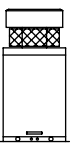
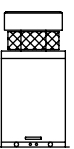
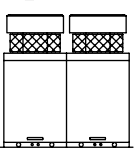
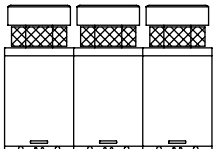
	Standard Blower Rooftop Arrangements B, C	Standard Blower w/Evap. Rooftop Arrangements D, E	High CFM Blower Rooftop Arrangements G, J	High CFM Blower w/Cooling Rooftop Arrangements K, L †
Furnace Type A, B $\Delta T_{20} - 60F^*$  [α(RT/PV)-100/400H]	Capacity 10 - 40 10 - 1,200-3,500 CFM, 1/2 - 5 HP. 15 - 2,000-4,500 CFM, 1/2 - 5 HP. 20 - 2,500-5,500 CFM, 1/2 - 5 HP. 25 - 3,000-5,500 CFM, 3/4 - 5 HP. 30 - 3,700-7,000 CFM, 3/4 - 5 HP. 35 - 4,500-8,500 CFM, 3/4 - 5 HP. 40 - 5,000-8,500 CFM, 1 - 5 HP. ESP 0.1 - 2.0 in. WC Chart #3 Tables #2,4	Capacity 10 - 40 10 - 1,200-3,500 CFM, 1/2 - 5 HP. 15 - 2,000-4,500 CFM, 1/2 - 5 HP. 20 - 2,500-5,500 CFM, 1/2 - 5 HP. 25 - 3,000-5,500 CFM, 3/4 - 5 HP. 30 - 3,700-7,000 CFM, 3/4 - 5 HP. 35 - 4,500-8,500 CFM, 3/4 - 5 HP. 40 - 5,000-8,500 CFM, 1 - 5 HP. ESP 0.1 - 2.0 in. WC Chart #3 Tables #2,4	Capacity 20 - 40 20 - 2,500-7,400 CFM, 3/4 - 10 HP. 25 - 3,100-7,500 CFM, 3/4 - 10 HP. 30 - 3,700-11,000 CFM, 1/2 - 15 HP. 35 - 4,500-13,000 CFM, 3/4 - 15 HP. 40 - 5,000-14,000 CFM, 1 - 15 HP. ESP 0.1 - 2.0 in. WC Chart #5 Tables #5,7	Capacity 10 - 40 10 - 960-3,000 CFM, 1/2 - 5 HP. 15 - 960-3,000 CFM, 1/2 - 5 HP. 20 - 1,600-4,400 CFM, 3/4 - 10 HP. 25 - 1,600-4,400 CFM, 3/4 - 10 HP. 30 - 1,900-5,700 CFM, 1/2 - 15 HP. 35 - 1,900-5,700 CFM, 3/4 - 15 HP. 40 - 2,100-6,300 CFM, 1 - 15 HP. ESP 0.1 - 2.0 in. WC Chart #5 Tables #5,7,8,9
Furnace Type C, D $\Delta T_{60} - 90F^*$  [α(RT/PV)-100/400]	Capacity 10-40 10 - 800-1,200 CFM, 1/2 - 1-1/2HP. 15 - 1,200-1,800 CFM, 1/2 - 2 HP. 20 - 1,600-2,400 CFM, 1/2 - 2 HP. 25 - 2,000-3,000 CFM, 1/2 - 3 HP. 30 - 2,400-3,600 CFM, 1/2 - 5 HP. 35 - 2,800-4,200 CFM, 1/2 - 5 HP. 40 - 3,200-4,800 CFM, 1/2 - 5 HP. ESP 0.1 - 2.0 in. WC Chart #4 Tables #3,4	Capacity 10-40 10 - 800-1,200 CFM, 1/2 - 1-1/2HP. 15 - 1,200-1,800 CFM, 1/2 - 2 HP. 20 - 1,600-2,400 CFM, 1/2 - 2 HP. 25 - 2,000-3,000 CFM, 1/2 - 3 HP. 30 - 2,400-3,600 CFM, 1/2 - 5 HP. 35 - 2,800-4,200 CFM, 1/2 - 5 HP. 40 - 3,200-4,800 CFM, 1/2 - 5 HP. ESP 0.1 - 2.0 in. WC Chart #4 Tables #3,4	NA	Capacity 20 - 40 20 - 1,600-2,400 CFM, 1/2 - 2 HP. 25 - 1,600-3,000 CFM, 1/2 - 2 HP. 30 - 1,900-3,600 CFM, 1/2 - 5 HP. 35 - 1,900-4,200 CFM, 1/2 - 5 HP. 40 - 2,100-5,000 CFM, 1/2 - 5 HP. ESP 0.1 - 2.0 in. WC Chart #6 Tables #6,7,8,9
Furnace Type A, B $\Delta T_{40} - 120F^*$ 	Capacity 50 - 80 50 - 3,000-5,500 CFM, 1 - 5 HP. 60 - 3,700-6,500 CFM, 1 - 5 HP. 70 - 4,500-8,000 CFM, 1 - 5 HP. 80 - 5,000-8,000 CFM, 1 - 5 HP. ESP 0.1 - 2.0 in. WC Chart #3 Tables #2,4	Capacity 50 - 80 50 - 3,000-5,500 CFM, 1 - 5 HP. 60 - 3,700-6,500 CFM, 1 - 5 HP. 70 - 4,500-8,000 CFM, 1 - 5 HP. 80 - 5,000-8,000 CFM, 1 - 5 HP. ESP 0.1 - 2.0 in. WC Chart #3 Tables #2,4	Capacity 50 - 80 50 - 3,100-7,500 CFM, 1 - 10 HP. 60 - 3,700-11,000 CFM, 3/4 - 15 HP. 70 - 4,500-13,000 CFM, 1 - 15 HP. 80 - 5,000-13,500 CFM, 1 - 15 HP. ESP 0.1 - 2.0 in. WC Chart #5 Tables #5,7	Capacity 50 - 80 50 - 1,600-4,400 CFM, 1 - 10 HP. 60 - 1,900-5,700 CFM, 3/4 - 15 HP. 70 - 1,900-5,700 CFM, 1 - 15 HP. 80 - 2,100-6,300 CFM, 1 - 15 HP. ESP 0.1 - 2.0 in. WC Chart #5 Tables #5,7,8,9
Furnace Type A, B $\Delta T_{60} - 180F^*$ 	NA	NA	Capacity 12 12 - 5,500-13,000 CFM, 1-1/2 - 15 HP. ESP 0.1 - 2.0 in. WC Chart #5 Tables #5,7	NA

†These minimum and maximum CFM's shown are for Arrangements K & L in the cooling mode. See Performance Data on pages 22 through 25 for heating mode specifications.

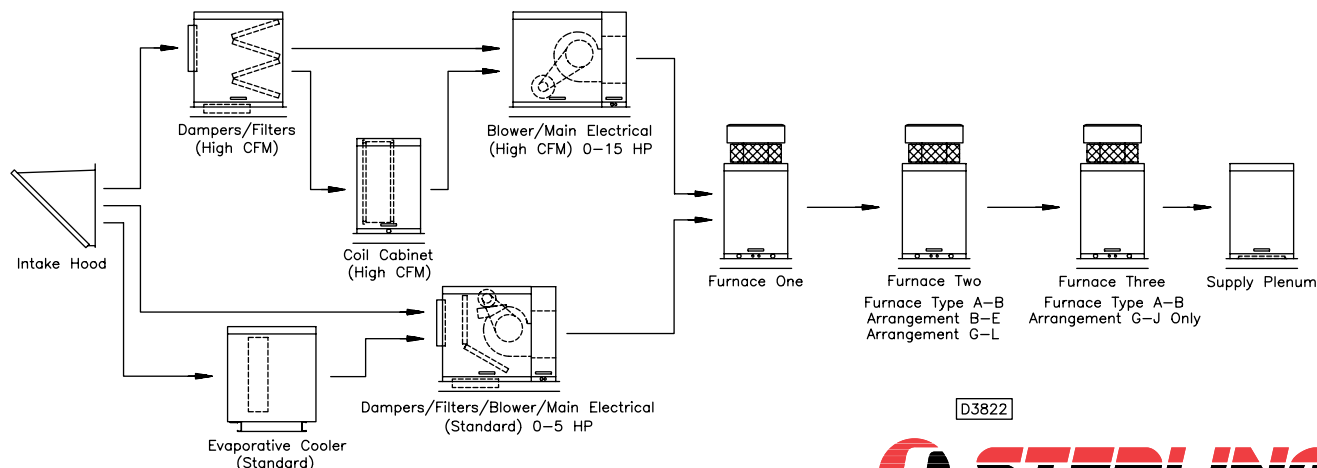

D3822



Quick Sizer Chart No. 3

Furnace Type - (A,B) Standard Temperature Rise
 Rooftop Arrangement - (B,C,D,E)

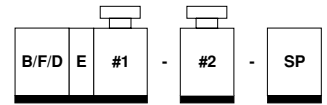

ARRANGEMENTS

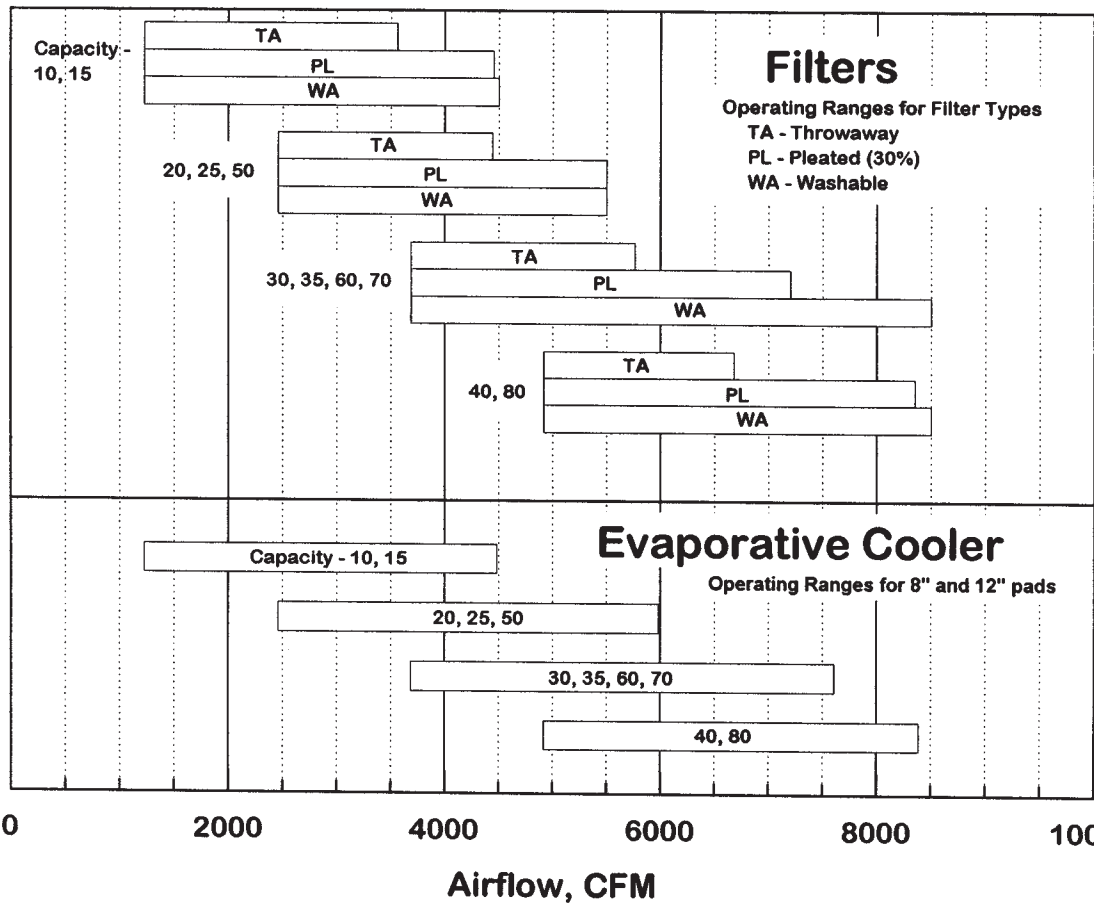
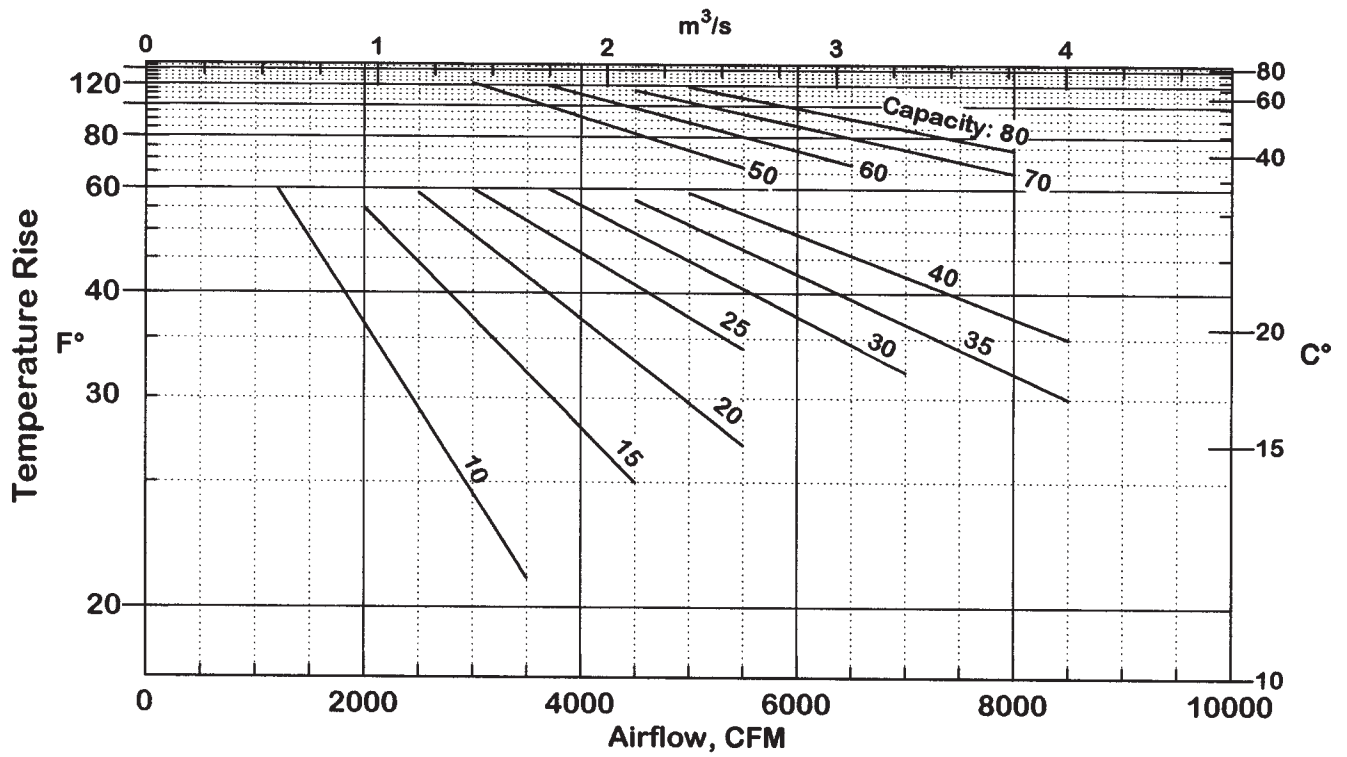

Quick Sizer Chart No. 4

Furnace Type - (C,D) High Temperature Rise
 Rooftop Arrangement - (B,C,D,E)

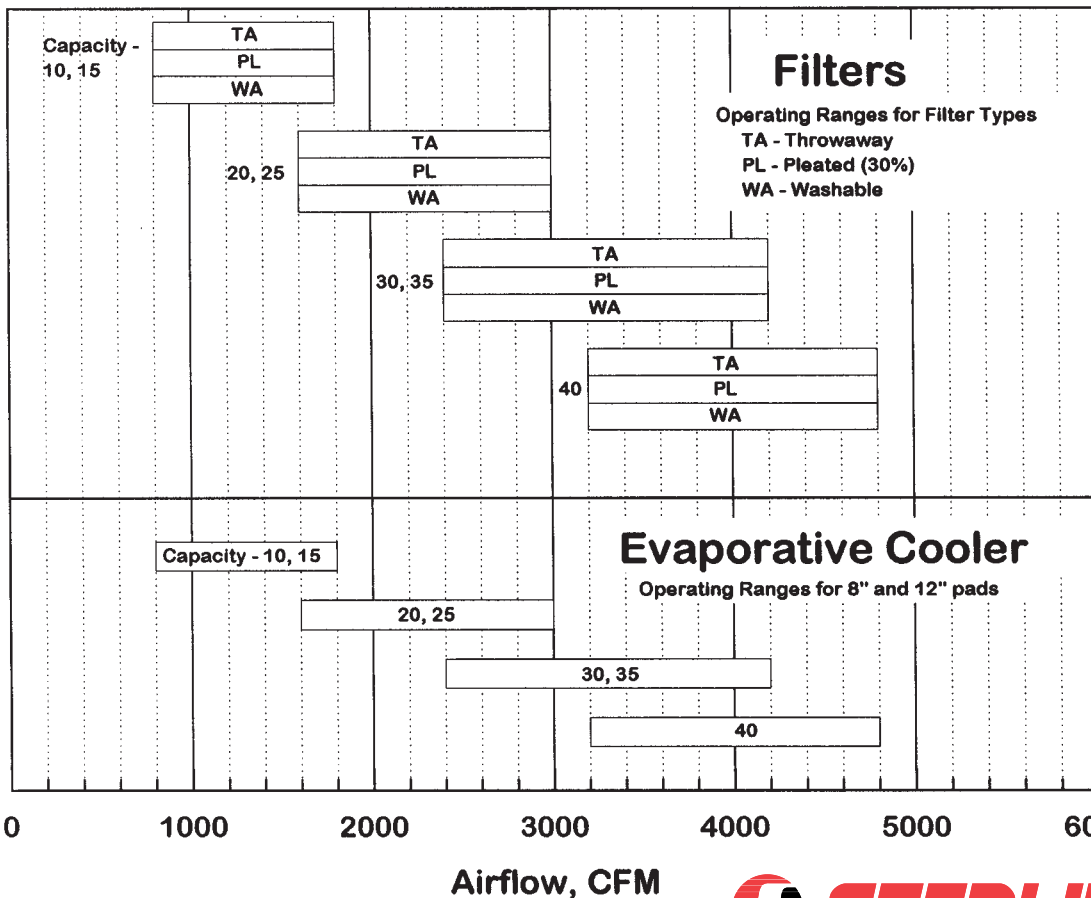
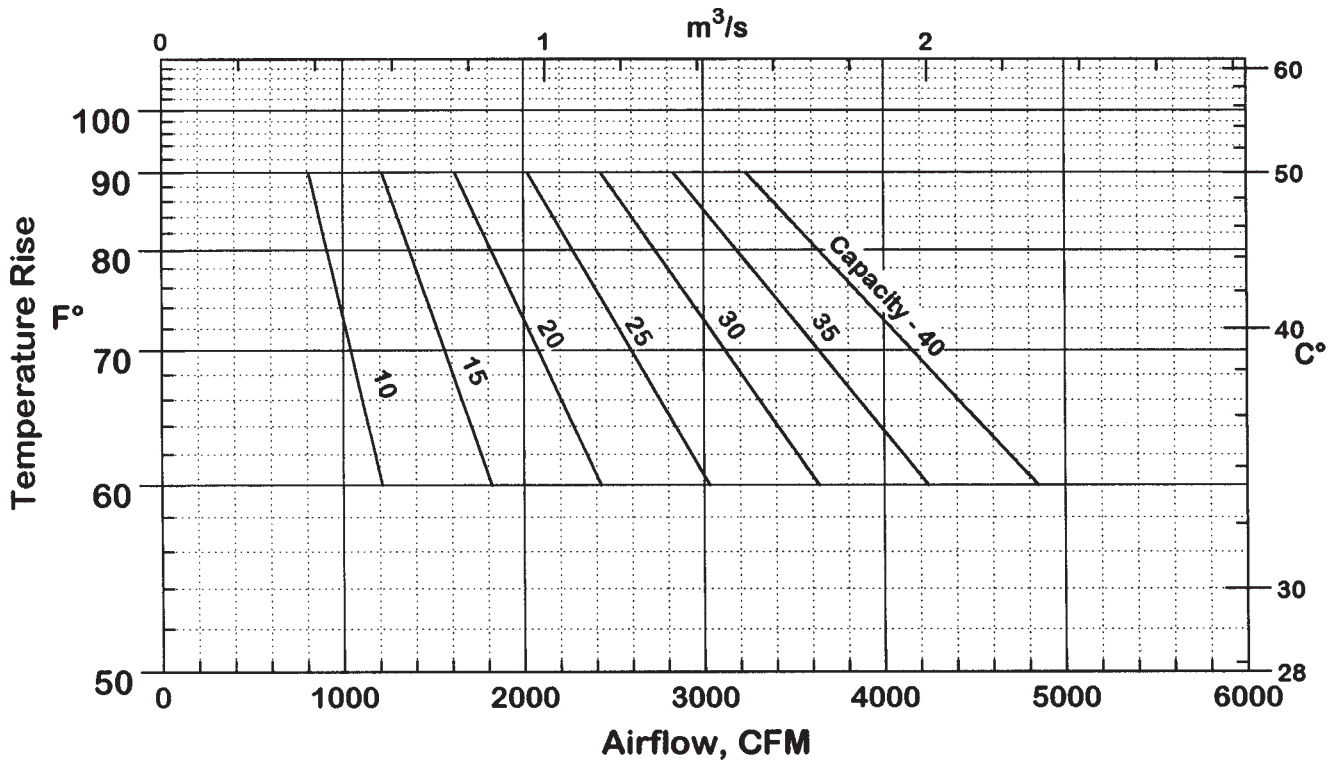
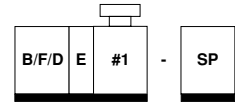

ARRANGEMENTS



Performance – Table 2

Furnace Type (A,B) Standard Temperature Rise
Rooftop Arrangement (B,C,D,E)

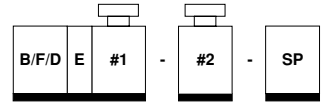

TOTAL STATIC PRESSURE (INCHES OF WATER)

Capacity Furnace Type	TR (F°)	Input BTU/H	Output BTU/H	0.2		0.4		0.6		0.8		1		1.2		1.4		1.6		1.8		2					
				RPM	BHP	RPM	BHP	RPM	BHP	RPM	BHP	RPM	BHP	RPM	BHP	RPM	BHP	RPM	BHP	RPM	BHP	RPM	BHP	RPM	BHP	RPM	BHP
				CFM		BTU/H		CFM		BTU/H		CFM		BTU/H		CFM		BTU/H		CFM		BTU/H		CFM		BTU/H	
10-A,B	61	1,200	100,000	80,000	0.16	705	0.23	825	0.31	940	0.40	1040	0.50	1135	0.60	1220	0.70	1300	0.80	1375	0.91	1440	1.02				
	49	1,500	120,000	90,000	0.26	765	0.35	870	0.44	965	0.53	1060	0.64	1150	0.75	1235	0.87	1315	0.99	1390	1.12	1460	1.24				
	37	2,000	160,000	120,000	0.55	890	0.65	975	0.77	1055	0.88	1130	1.00	1205	1.12	1280	1.25	1355	1.39	1425	1.54	1490	1.68				
15-A,B	29	2,500	200,000	150,000	1.01	1030	1.12	1105	1.25	1175	1.39	1240	1.54	1305	1.68	1365	1.83	1425	1.98	1485	2.13	1545	2.29				
	25	3,000	240,000	180,000	1.68	1175	1.82	1240	1.95	1305	2.10	1365	2.27	1425	2.42	1475	2.62	1530	2.79	1580	2.97	1635	3.14				
	21	3,500	280,000	210,000	2.59	1330	2.77	1385	2.93	1440	3.08	1495	3.25	1550	3.43	1600	3.63	1650	3.83	1695	4.04	1745	4.25				
20-A,B	59	2,500	200,000	160,000	0.44	785	0.54	880	0.63	965	0.75	1045	0.87	1120	0.98	1195	1.11	1270	1.24	1345	1.37	1415	1.52				
	47	3,000	240,000	180,000	0.78	890	0.91	970	1.04	1045	1.15	1120	1.28	1190	1.43	1255	1.57	1320	1.72	1380	1.86	1440	2.01				
	34	4,000	320,000	240,000	1.28	1005	1.44	1075	1.60	1140	1.75	1205	1.88	1270	2.02	1335	2.18	1390	2.35	1450	2.53	1500	2.70				
25-A,B	29	5,000	500,000	400,000	2.98	1010	3.15	1060	3.32	1110	3.50	1160	3.70	1205	3.90	1255	4.12	1300	4.35	1345	4.57	1390	4.80				
	27	5,500	550,000	450,000	3.92	1050	4.11	1095	4.30	1140	4.49	1185	4.72	1225	4.91	1270	5.10	1310	5.30	1355	5.50	1400	5.70				
	21	6,000	600,000	500,000	4.44	1100	4.64	1145	4.84	1190	5.04	1235	5.25	1280	5.45	1325	5.65	1370	5.85	1415	6.05	1460	6.25				
30-A,B	34	6,500	650,000	500,000	0.55	850	0.65	925	0.75	1000	0.85	1075	0.95	1150	1.05	1225	1.15	1300	1.25	1375	1.35	1450	1.45				
	32	7,000	700,000	550,000	0.71	910	0.83	985	0.96	1060	1.09	1135	1.23	1210	1.37	1285	1.51	1360	1.65	1435	1.79	1510	1.93				
	29	7,500	750,000	600,000	1.44	1035	1.60	1095	1.86	1155	2.03	1215	2.21	1275	2.39	1335	2.57	1395	2.76	1455	2.94	1515	3.13				
35-A,B	37	8,000	800,000	600,000	3.92	1050	4.11	1095	4.30	1140	4.49	1185	4.72	1225	4.91	1270	5.10	1310	5.30	1355	5.50	1400	5.70				
	34	8,500	850,000	700,000	4.44	1100	4.64	1145	4.84	1190	5.04	1235	5.25	1280	5.45	1325	5.65	1370	5.85	1415	6.05	1460	6.25				
	32	9,000	900,000	750,000	5.00	1150	5.25	1200	5.50	1250	5.75	1300	6.00	1350	6.25	1400	6.50	1450	6.75	1500	7.00	1550	7.25				
40-A,B	42	9,500	950,000	750,000	0.73	920	0.84	995	0.97	1070	1.10	1145	1.24	1220	1.34	1295	1.44	1370	1.54	1445	1.64	1520	1.74				
	40	10,000	1,000,000	800,000	0.89	980	1.03	1055	1.18	1130	1.33	1205	1.48	1280	1.63	1355	1.78	1430	1.93	1505	2.08	1580	2.23				
	38	10,500	1,050,000	850,000	1.05	1040	1.21	1115	1.42	1190	1.63	1265	1.84	1340	1.99	1415	2.18	1490	2.39	1565	2.60	1640	2.81				
50-A,B	52	11,000	1,100,000	900,000	3.25	1075	3.58	1140	3.92	1200	4.26	1260	4.58	1320	4.86	1380	5.14	1440	5.42	1500	5.70	1560	6.00				
	50	11,500	1,150,000	950,000	3.82	1130	4.18	1190	4.53	1250	4.86	1310	5.14	1370	5.42	1430	5.70	1490	6.00	1550	6.25	1610	6.50				
	48	12,000	1,200,000	1,000,000	4.40	1190	4.74	1250	5.08	1310	5.42	1370	5.74	1430	6.00	1490	6.25	1550	6.50	1610	6.75	1670	7.00				
60-A,B	67	12,500	1,250,000	1,000,000	0.85	1000	1.12	1075	1.26	1150	1.40	1225	1.55	1300	1.69	1375	1.84	1450	2.03	1525	2.22	1600	2.41				
	65	13,000	1,300,000	1,100,000	1.12	1060	1.27	1135	1.42	1210	1.57	1285	1.72	1360	1.87	1435	2.02	1510	2.17	1585	2.36	1660	2.55				
	63	13,500	1,350,000	1,200,000	1.39	1120	1.54	1195	1.69	1270	1.84	1345	2.00	1420	2.15	1495	2.30	1570	2.45	1645	2.60	1720	2.75				
70-A,B	74	14,000	1,400,000	1,200,000	1.25	1100	1.37	1175	1.52	1250	1.67	1325	1.82	1400	1.97	1475	2.12	1550	2.27	1625	2.42	1700	2.57				
	72	14,500	1,450,000	1,300,000	1.48	1160	1.72	1235	1.87	1310	2.02	1385	2.17	1460	2.32	1535	2.47	1610	2.62	1685	2.77	1760	2.92				
	70	15,000	1,500,000	1,400,000	2.25	1220	2.50	1295	2.65	1370	2.80	1445	2.95	1520	3.10	1595	3.25	1670	3.40	1745	3.55	1820	3.70				
80-A,B	84	15,500	1,550,000	1,400,000	0.85	1000	1.12	1075	1.26	1150	1.40	1225	1.55	1300	1.69	1375	1.84	1450	2.03	1525	2.22	1600	2.41				
	82	16,000	1,600,000	1,500,000	1.12	1060	1.27	1135	1.42	1210	1.57	1285	1.72	1360	1.87	1435	2.02	1510	2.17	1585	2.36	1660	2.55				
	80	16,500	1,650,000	1,600,000	1.39	1120	1.54	1195	1.69	1270	1.84	1345	2.00	1420	2.15	1495	2.30	1570	2.45	1645	2.60	1720	2.75				
90-A,B	92	17,000	1,700,000	1,600,000	1.25	1100	1.37	1175	1.52	1250	1.67	1325	1.82	1400	1.97	1475	2.12	1550	2.27	1625	2.42	1700	2.57				
	90	17,500	1,750,000	1,700,000	1.48	1160	1.72	1235	1.87	1310	2.02	1385	2.17	1460	2.32	1535	2.47	1610	2.62	1685	2.77	1760	2.92				
	88	18,000	1,800,000	1,800,000	2.25	1220	2.50	1295	2.65	1370	2.80	1445	2.95	1520	3.10	1595	3.25	1670	3.40	1745	3.55	1820	3.70				
100-A,B	115	18,500	1,850,000	1,800,000	0.85	1000	1.12	1075	1.26	1150	1.40	1225	1.55	1300	1.69	1375	1.84	1450	2.03	1525	2.22	1600	2.41				
	113	19,000	1,900,000	1,900,000	1.12	1060	1.27	1135	1.42	1210	1.57	1285	1.72	1360	1.87	1435	2.02	1510	2.17	1585	2.36	1660	2.55				
	111	19,500	1,950,000	2,000,000	1.39	1120	1.54	1195	1.69	1270	1.84	1345	2.00	1420	2.15	1495	2.30	1570	2.45	1645	2.60	1720	2.75				
110-A,B	123	20,000	2,000,000	2,000,000	1.25	1100	1.37	1175	1.52	1250	1.67	1325	1.82	1400	1.97	1475	2.12	1550	2.27	1625	2.42	1700	2.57				
	121	20,500	2,050,000	2,100,000	1.48	1160	1.72	1235	1.87	1310	2.02	1385	2.17	1460	2.32	1535	2.47	1610	2.62	1685	2.77	1760	2.92				
	119	21,000	2,100,000	2,200,000	2.25	1220	2.50	1295	2.65	1370	2.80	1445	2.95	1520	3.10	1595	3.25	1670	3.40	1745	3.55	1820	3.70				
120-A,B	135	21,500	2,150,000	2,200,000	0.85	1000	1.12	1075	1.26	1150	1.40	1225	1.55	1300	1.69	1375	1.84	1450	2.03	1525	2.22	1600	2.41				
	133	22,000	2,200,000	2,300,000	1.12	1060	1.27	1135	1.42	1210	1.57	1285	1.72	1360	1.87	1435	2.02	1510	2.17	1585	2.36	1660	2.55				
	131	22,500	2,250,000	2,400,000	1.39	1120	1.54	1195	1.69	1270	1.84	1345	2.00	1420	2.15	1495	2.30	1570	2.45	1645	2.60	1720	2.75				
130-A,B	147	23,000	2,300,000	2,400,000	1.25	1100	1.37	1175	1.52	1250	1.67	1325	1.82	1400	1.97	1475	2.12	1550	2.27	1625	2.42	1700	2.57				
	145	23,500	2,350,000	2,500,000	1.48	1160	1.72	1235	1.																		

Performance – Table 3

Furnace Type (C,D) High Temperature Rise Rooftop Arrangement (B,C,D,E)

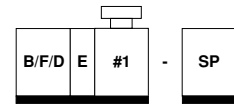

Capacity Furnace Type	TR (°F)	CFM	Input BTU/H	Output BTU/H	TOTAL STATIC PRESSURE (INCHES OF WATER)																			
					0.2		0.4		0.6		0.8		1		1.2		1.4		1.6		1.8			
					RPM	BHP	RPM	BHP	RPM	BHP	RPM	BHP	RPM	BHP	RPM	BHP	RPM	BHP	RPM	BHP	RPM	BHP		
10-C,D	81	800	100,000	79,000	550	.09	710	.15	840	.22	950	.29	1045	.37	1135	.45	1210	.53	1285	.61	1355	.69	1420	.78
	91	900	100,000	79,000	575	.11	730	.18	855	.25	965	.33	1065	.41	1150	.50	1230	.58	1305	.67	1375	.76	1440	.86
15-C,D	73	1,000	150,000	118,500	605	.14	745	.21	870	.29	980	.37	1080	.46	1165	.55	1245	.64	1320	.74	1390	.83	1455	.93
	66	1,100	150,000	118,500	635	.17	770	.25	890	.33	995	.42	1095	.51	1180	.61	1260	.71	1335	.81	1410	.91	1475	1.01
20-C,D	61	1,200	200,000	158,000	670	.21	795	.29	910	.38	1015	.47	1110	.57	1195	.67	1280	.77	1355	.88	1425	.99	1490	1.10
	91	1,200	200,000	158,000	580	.16	705	.23	830	.31	940	.40	1045	.50	1135	.60	1220	.70	1300	.80	1375	.91	1445	1.02
25-C,D	78	1,400	250,000	197,500	630	.23	745	.31	855	.39	960	.49	1055	.59	1150	.70	1235	.81	1315	.93	1385	1.05	1460	1.17
	68	1,600	250,000	197,500	685	.31	795	.40	890	.50	985	.60	1075	.70	1160	.82	1245	.94	1325	1.07	1400	1.19	1470	1.33
30-C,D	61	1,800	300,000	237,000	740	.42	845	.52	935	.62	1020	.73	1100	.84	1180	.96	1260	1.09	1340	1.22	1410	1.36	1480	1.50
	91	1,600	300,000	237,000	500	.19	615	.26	720	.35	815	.44	900	.54	980	.64	1055	.76	1130	.88	1200	1.00	1270	1.13
35-C,D	81	1,800	350,000	276,500	530	.24	640	.33	735	.42	830	.51	915	.62	990	.73	1060	.84	1130	.96	1200	1.09	1265	1.23
	73	2,000	350,000	276,500	560	.31	665	.41	755	.50	845	.60	925	.71	1000	.83	1075	.95	1140	1.07	1205	1.20	1265	1.34
40-C,D	66	2,200	400,000	316,000	595	.40	695	.50	780	.60	860	.71	940	.82	1015	.94	1085	1.07	1150	1.19	1215	1.33	1270	1.47
	61	2,400	400,000	316,000	635	.49	725	.60	805	.71	885	.83	955	.95	1030	1.07	1095	1.20	1160	1.34	1225	1.48	1285	1.62
45-C,D	91	2,000	450,000	355,000	540	.30	645	.39	740	.48	825	.58	910	.69	985	.80	1060	.92	1125	1.05	1190	1.18	1250	1.31
	81	2,250	450,000	355,000	580	.39	680	.50	765	.60	850	.71	925	.82	1000	.94	1070	1.07	1140	1.20	1200	1.33	1260	1.47
50-C,D	73	2,500	500,000	394,000	625	.51	715	.63	795	.74	875	.86	945	.98	1015	1.10	1085	1.23	1150	1.37	1210	1.51	1270	1.66
	66	2,750	500,000	394,000	665	.66	750	.78	830	.90	905	1.03	970	1.16	1035	1.29	1100	1.43	1160	1.57	1225	1.72	1280	1.87
55-C,D	61	3,000	600,000	475,000	710	.83	790	.96	865	1.10	935	1.23	1000	1.37	1065	1.51	1125	1.66	1180	1.81	1240	1.96	1295	2.12
	91	2,400	600,000	475,000	585	.33	710	.47	835	.63	945	.81	1045	1.00	1140	1.20	1225	1.41	1305	1.62	1375	1.83	1445	2.05
60-C,D	81	2,700	650,000	514,000	625	.43	740	.58	850	.75	960	.94	1055	1.14	1150	1.36	1235	1.58	1315	1.80	1390	2.04	1460	2.27
	73	3,000	650,000	514,000	665	.54	775	.72	875	.90	975	1.09	1070	1.30	1160	1.53	1245	1.76	1325	2.00	1395	2.25	1470	2.50
65-C,D	66	3,300	750,000	594,000	705	.69	81	.87	905	1.07	1000	1.27	1085	1.49	1175	1.72	1255	1.97	1335	2.22	1405	2.48	1475	2.75
	61	3,600	750,000	594,000	750	.86	850	1.05	940	1.26	1025	1.47	1110	1.70	1190	1.94	1270	2.20	1345	2.46	1415	2.74	1485	3.02
70-C,D	91	2,800	800,000	616,000	485	.30	610	.44	720	.60	815	.77	905	.96	990	1.17	1070	1.40	1145	1.63	1215	1.87	1280	2.12
	82	3,100	800,000	616,000	510	.37	625	.52	730	.69	825	.87	910	1.07	990	1.28	1070	1.51	1140	1.75	1210	2.00	1280	2.26
75-C,D	75	3,400	900,000	694,000	535	.46	645	.62	745	.79	840	.98	920	1.19	1000	1.40	1070	1.63	1140	1.88	1210	2.14	1275	2.41
	69	3,700	900,000	694,000	560	.56	665	.73	760	.91	850	1.11	935	1.32	1010	1.55	1080	1.78	1145	2.03	1210	2.29	1275	2.57
80-C,D	64	4,000	1,000,000	794,000	590	.67	690	.86	780	1.05	865	1.26	945	1.48	1020	1.71	1090	1.95	1155	2.20	1220	2.47	1280	2.75
	61	4,200	1,000,000	794,000	605	.76	705	.95	790	1.15	875	1.36	950	1.59	1025	1.82	1095	2.07	1160	2.33	1225	2.60	1285	2.88
85-C,D	91	3,200	1,100,000	854,000	500	.38	620	.53	725	.70	820	.88	905	1.08	985	1.29	1060	1.52	1130	1.76	1205	2.01	1270	2.28
	81	3,600	1,100,000	854,000	535	.50	645	.66	740	.84	830	1.04	915	1.24	995	1.46	1065	1.69	1135	1.94	1200	2.20	1265	2.47
90-C,D	73	4,000	1,200,000	954,000	570	.64	670	.82	760	1.01	845	1.22	930	1.43	1005	1.66	1075	1.90	1145	2.15	1205	2.42	1265	2.69
	66	4,400	1,200,000	954,000	605	.80	700	1.01	785	1.21	865	1.43	945	1.66	1020	1.90	1090	2.15	1155	2.41	1215	2.68	1275	2.96
95-C,D	61	4,800	1,300,000	1,054,000	640	1.00	730	1.22	815	1.44	890	1.67	960	1.91	1035	2.16	1100	2.42	1165	2.69	1230	2.97	1285	3.26

- Notes: 1. Refer to Table 4 for Accessory Pressure Losses.
 2. Values in Tables 2 and 3 are based on the "Basic Packaged Unit" which includes pressure drop of the Duct Furnace(s) and "system effect" of the Blower Module.
 3. Brake Horsepower (BHP) includes drive losses.
 4. Unit leaving air temperature is limited to 150° F (66° C) and is equal to: Entering Air Temperature + Duct Furnace(s) Temperature Rise.
 5. "Total Static Pressure" is the sum of the unit's "Internal" accessory pressure loss(es) from Table 4, plus the external static pressure.
 6. Ratings shown are for elevations between 0 and 2000 ft. (610 m). For unit installations in the U.S.A. above 2000 ft. (610 m), the unit input must be derated 4% for each 1000 ft. (305 m) above sea level; refer to local codes, or in the absence of local codes, refer to the National Fuel Gas Code, ANSI Standard Z223.1-1992 (N.F.P.A. No. 54), or the latest edition of.
- For installations in Canada, any references to deration at altitudes in excess of 2000 ft. (610m) are to be ignored. At altitudes of 2000 to 4500 ft. (610 to 1372m), the unit must be derated to 90% of the normal rating, and be so marked in accordance with the C.G.A. certification.



Accessory Pressure Loss — Table 4

Rooftop Arrangements (B,C,D,E) — (M,N,P,R)

B/F/D	E
-------	---

PRESSURE LOSS (INCHES OF WATER)

Capacity CFM	Rainhood		Filters				Supply		Evaporative		Return or Outside Air Damper
	Screen	With Mstr.Elim.	Throwaway		Washable		Plenum	Media	8"	12"	
			2"	1"	1"	2"					
10	<.01	.01	.03	<.01	<.01	<.01	.03	.02	.01	.02	.01
	.01	.01	.03	<.01	<.01	<.01	.03	.02	.02	.02	.02
	.02	.02	.04	<.01	<.01	<.01	.04	.03	.02	.04	.03
	.02	.02	.05	<.01	<.01	<.01	.05	.04	.03	.04	.03
	.03	.04	.06	.01	.02	.02	.07	.06	.04	.07	.05
	.05	.07	.09	.02	.03	.03	.12	.10	.08	.12	.09
	.08	.11	.12	.03	.04	.04	.17	.10	.12	.18	.13
	.11	.15	.16	.04	.06	.06	.23	.14	.17	.26	.19
	.16	.21	.19	.06	.08	.08	.30	.23	.24	.35	.25
	.21	.26	.25	.09	.11	.11	.38	.27	.27	.42	.33
15	.02	.02	.05	<.01	<.01	.05	.03	.03	.04	.04	.03
	.03	.03	.06	<.01	<.01	.06	.04	.03	.04	.06	.04
	.03	.04	.07	.01	.02	.08	.04	.04	.05	.07	.06
	.04	.05	.08	.02	.02	.10	.05	.06	.06	.09	.07
	.05	.07	.09	.02	.03	.12	.07	.07	.08	.12	.09
	.08	.11	.12	.03	.04	.17	.10	.11	.12	.18	.13
	.11	.15	.16	.04	.06	.23	.14	.15	.17	.26	.19
	.16	.21	.19	.06	.08	.30	.21	.21	.24	.35	.25
	.20	.27	-	.07	.11	.38	.23	.27	N/A	N/A	.33
	.26	.34	-	.09	.14	-	-	.34	N/A	N/A	.42
20	.02	.02	.05	<.01	<.01	.06	.03	.02	.02	.03	.03
	.02	.03	.06	<.01	<.01	.07	.04	.03	.02	.03	.03
	.02	.03	.07	.01	.02	.08	.04	.03	.03	.04	.04
	.03	.04	.08	.01	.02	.09	.05	.04	.03	.05	.05
	.03	.05	.09	.02	.02	.11	.06	.05	.04	.06	.05
	.04	.05	.09	.02	.03	.12	.07	.05	.04	.07	.06
	.05	.07	.12	.03	.04	.16	.09	.07	.06	.10	.08
	.09	.13	.17	.05	.07	.26	.13	.13	.11	.17	.15
	.15	.20	-	.07	.11	.38	.23	.21	.18	.27	.23
	.18	.25	-	.09	.13	.44	.28	.25	.22	.32	.28
25	.02	.03	.07	.01	.02	.08	.04	.02	.03	.04	.04
	.03	.04	.08	.02	.02	.10	.05	.03	.04	.05	.05
	.04	.05	.09	.02	.03	.12	.07	.04	.04	.07	.06
	.04	.06	.10	.02	.03	.14	.08	.04	.05	.08	.07
	.05	.07	.12	.03	.04	.16	.09	.05	.06	.10	.08
	.09	.13	.17	.05	.07	.26	.16	.11	.11	.17	.15
	.12	.16	-	.06	.09	.31	.19	.12	.15	.22	.19
	.15	.20	-	.07	.11	.38	.23	.14	.18	.27	.23
	.18	.25	-	.09	.13	.44	.28	.17	.22	.32	.28

Accessory Pressure Loss – Table 4

Rooftop Arrangements (B,C,D,E) — (M,N,P,R) *continued*

B/F/D	E
-------	---

ARRANGEMENTS

30	2,400	.02	.03	.06	.01	.07	.04	.02	.03	.04	.03	.04	.03
	2,700	.02	.03	.07	.01	.09	.05	.03	.03	.05	.03	.05	.04
	3,000	.03	.04	.08	.02	.10	.06	.03	.04	.06	.04	.06	.05
	3,300	.04	.05	.09	.02	.12	.07	.04	.05	.07	.05	.07	.06
	3,600	.04	.06	.10	.02	.14	.08	.05	.06	.08	.06	.09	.07
	4,000	.05	.08	.12	.03	.17	.10	.06	.07	.10	.07	.11	.08
	5,000	.09	.12	.16	.04	.24	.14	.09	.11	.17	.11	.17	.13
	6,000	.12	.17	-	.06	.33	.20	.13	.16	.24	.16	.24	.19
	6,500	.14	.20	-	.07	.38	.23	.16	.19	.29	.19	.29	.22
	7,000	.17	.23	-	.09	.43	.27	.18	.22	.33	.22	.33	.25
35	2,800	.03	.04	.07	.01	.09	.05	.02	.04	.05	.04	.05	.04
	3,100	.03	.05	.08	.02	.11	.06	.03	.04	.06	.04	.07	.05
	3,400	.04	.06	.10	.02	.13	.07	.04	.05	.08	.05	.08	.06
	3,700	.05	.07	.11	.02	.15	.08	.04	.06	.09	.06	.09	.07
	4,000	.05	.08	.12	.03	.17	.10	.05	.07	.10	.07	.11	.08
	5,000	.09	.12	.16	.04	.24	.14	.08	.11	.17	.11	.17	.13
	6,000	.12	.17	-	.06	.33	.20	.11	.16	.24	.16	.24	.19
	7,000	.17	.23	-	.09	.43	.27	.15	.22	.33	.22	.33	.25
	8,000	.22	.31	-	.11	.49	.36	.19	.29	.44	.29	.44	.33
	9,000	.28	.39	-	-	-	-	.24	N/A	N/A	N/A	N/A	.42
40	3,200	.03	.04	.07	.01	.09	.05	.02	.04	.05	.04	.06	.04
	3,600	.04	.05	.09	.02	.11	.06	.03	.05	.07	.05	.07	.05
	4,000	.04	.06	.10	.02	.13	.07	.04	.06	.09	.06	.09	.07
	4,400	.05	.07	.11	.03	.15	.09	.05	.07	.11	.07	.11	.08
	4,800	.06	.09	.13	.03	.18	.10	.05	.09	.13	.09	.13	.10
	5,000	.07	.10	.13	.03	.19	.11	.06	.10	.14	.09	.14	.10
	6,000	.10	.14	.17	.05	.26	.16	.08	.14	.20	.14	.20	.15
	7,000	.13	.19	-	.07	.33	.21	.11	.18	.27	.18	.27	.20
	8,000	.17	.24	-	.09	.42	.26	.15	.24	.36	.24	.36	.26
	8,500	.20	.28	-	.10	.44	-	.17	.27	.41	.27	.41	.30
50	3,000	.05	.07	.12	.03	.16	.09	.05	.06	.10	.06	.10	.08
	3,500	.07	.10	.14	.04	.21	.12	.07	.09	.13	.09	.13	.11
	4,000	.09	.13	.17	.05	.26	.16	.09	.11	.17	.11	.17	.15
	4,500	.12	.16	-	.06	.31	.19	.12	.15	.22	.15	.22	.19
	5,000	.15	.20	-	.07	.38	.23	.14	.18	.27	.18	.27	.23
	5,500	.18	.25	-	.09	.44	.28	.17	.22	.32	.22	.32	.28
	3,700	.05	.07	.11	.02	.15	.08	.05	.06	.09	.06	.09	.07
	4,000	.05	.08	.12	.03	.17	.10	.06	.07	.11	.07	.11	.08
	5,000	.09	.12	.16	.04	.24	.14	.09	.11	.17	.11	.17	.13
	6,000	.12	.17	-	.06	.33	.20	.13	.16	.24	.16	.24	.19
60	6,500	.14	.20	-	.07	.38	.23	.16	.24	.19	.24	.19	
	4,500	.07	.10	.14	.04	.20	.12	.06	.06	.14	.09	.14	.11
	5,000	.09	.12	.16	.04	.24	.14	.09	.11	.17	.11	.17	.13
	6,000	.12	.17	-	.06	.33	.20	.13	.16	.24	.16	.24	.19
	7,000	.17	.23	-	.09	.43	.27	.15	.22	.33	.22	.33	.25
	8,000	.22	.31	-	.11	.49	-	.19	.29	.44	.29	.44	.33
	5,000	.07	.10	.13	.03	.19	.11	.06	.09	.14	.09	.14	.10
	6,000	.10	.14	.17	.05	.26	.16	.08	.14	.20	.14	.20	.15
	7,000	.13	.19	-	.07	.33	.21	.11	.18	.27	.18	.27	.20
	8,000	.17	.24	-	.09	.42	.26	.15	.24	.36	.24	.36	.26
70	8,500	.20	.28	-	.10	.44	-	.17	.27	.27	.41	.30	
	3,000	.05	.07	.12	.03	.16	.09	.05	.06	.10	.06	.10	.08
	3,500	.07	.10	.14	.04	.21	.12	.07	.09	.13	.09	.13	.11
	4,000	.09	.13	.17	.05	.26	.16	.09	.11	.17	.11	.17	.15
	4,500	.12	.16	-	.06	.31	.19	.12	.15	.22	.15	.22	.19
	5,000	.15	.20	-	.07	.38	.23	.14	.18	.27	.18	.27	.23
	5,500	.18	.25	-	.09	.44	.28	.17	.22	.32	.22	.32	.28
	3,700	.05	.07	.11	.02	.15	.08	.05	.06	.09	.06	.09	.07
	4,000	.05	.08	.12	.03	.17	.10	.06	.07	.11	.07	.11	.08
	5,000	.09	.12	.16	.04	.24	.14	.09	.11	.17	.11	.17	.13
80	6,000	.12	.17	-	.06	.33	.20	.13	.16	.24	.16	.24	.19
	7,000	.17	.23	-	.09	.43	.27	.15	.22	.33	.22	.33	.25
	8,000	.22	.31	-	.11	.49	-	.19	.29	.44	.29	.44	.33
	5,000	.07	.10	.13	.03	.19	.11	.06	.09	.14	.09	.14	.10
	6,000	.10	.14	.17	.05	.26	.16	.08	.14	.20	.14	.20	.15
	7,000	.13	.19	-	.07	.33	.21	.11	.18	.27	.18	.27	.20
	8,000	.17	.24	-	.09	.42	.26	.15	.24	.36	.24	.36	.26



Quick Sizer Chart No. 5

Furnace Type - (A,B) Standard Temperature Rise
 Rooftop Arrangement - (G,J,K,L)

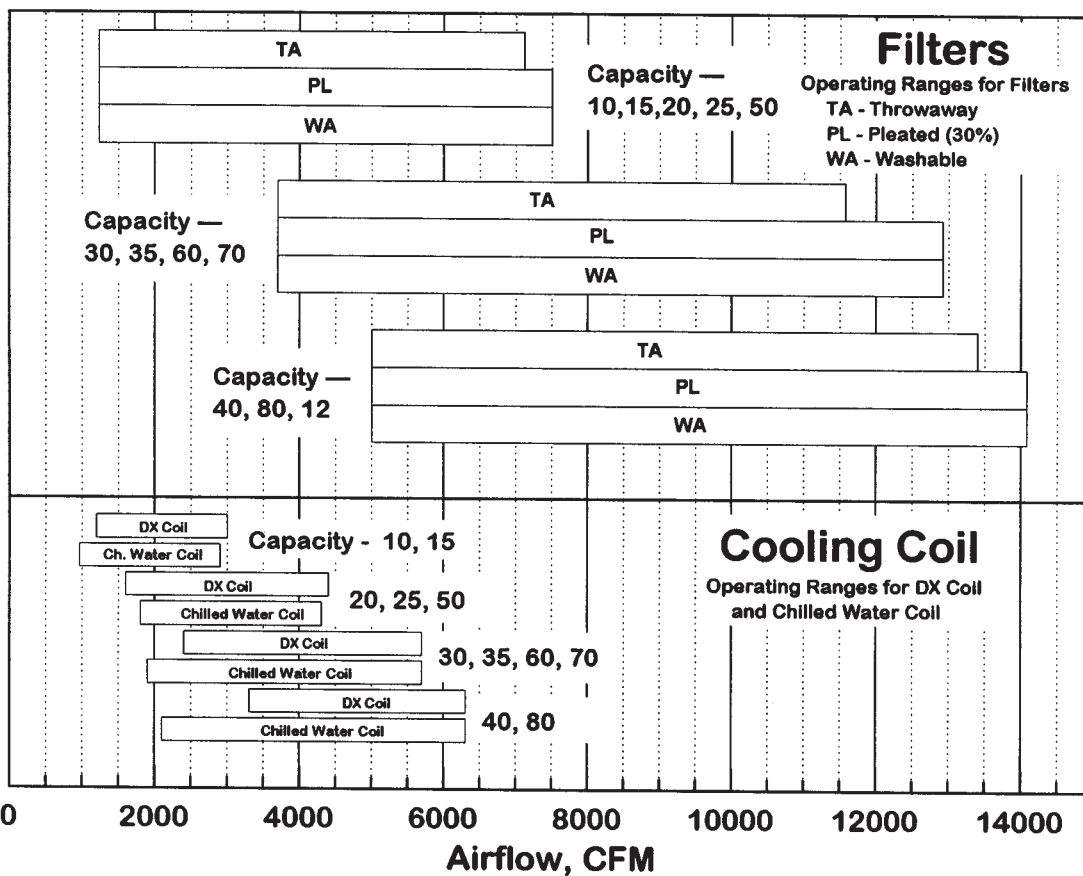
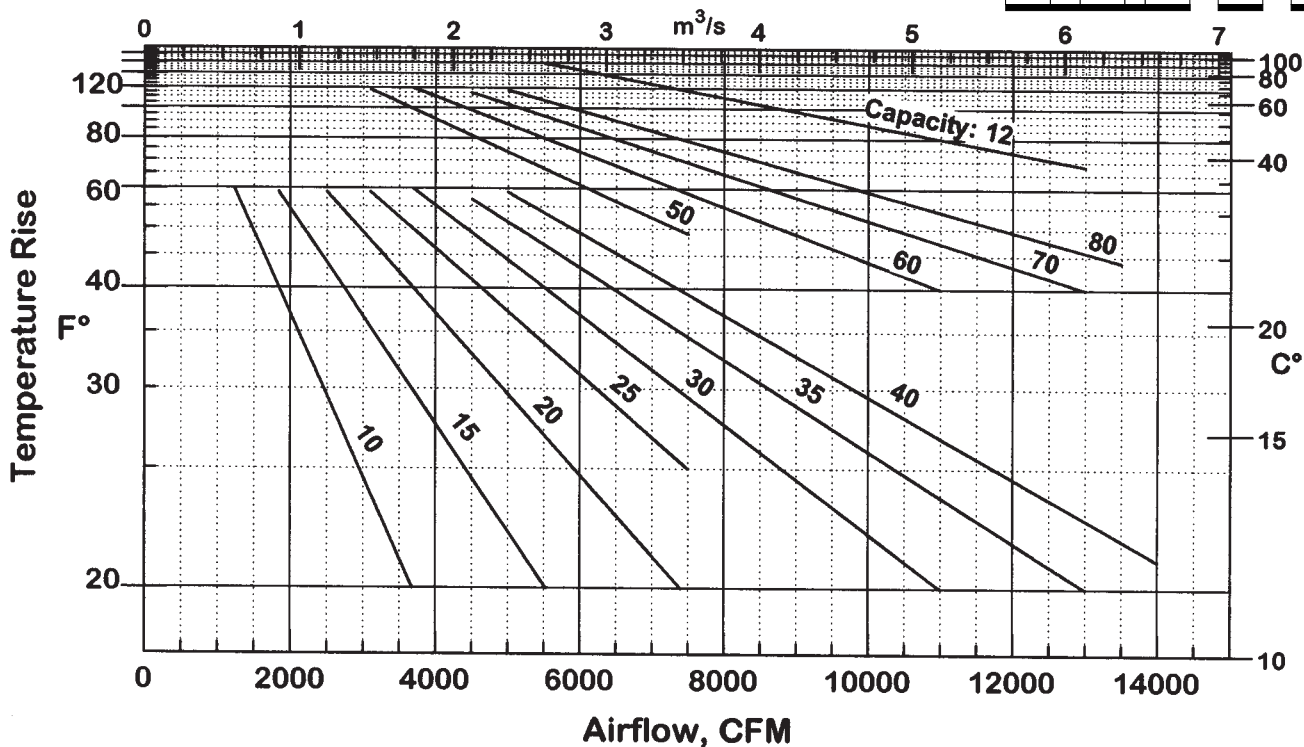
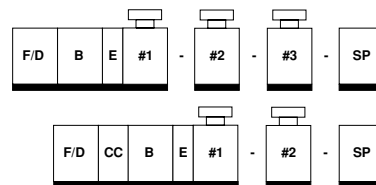

ARRANGEMENTS

Quick Sizer Chart No. 6

Furnace Type - (C,D) High Temperature Rise
 Rooftop Arrangement - (K,L)

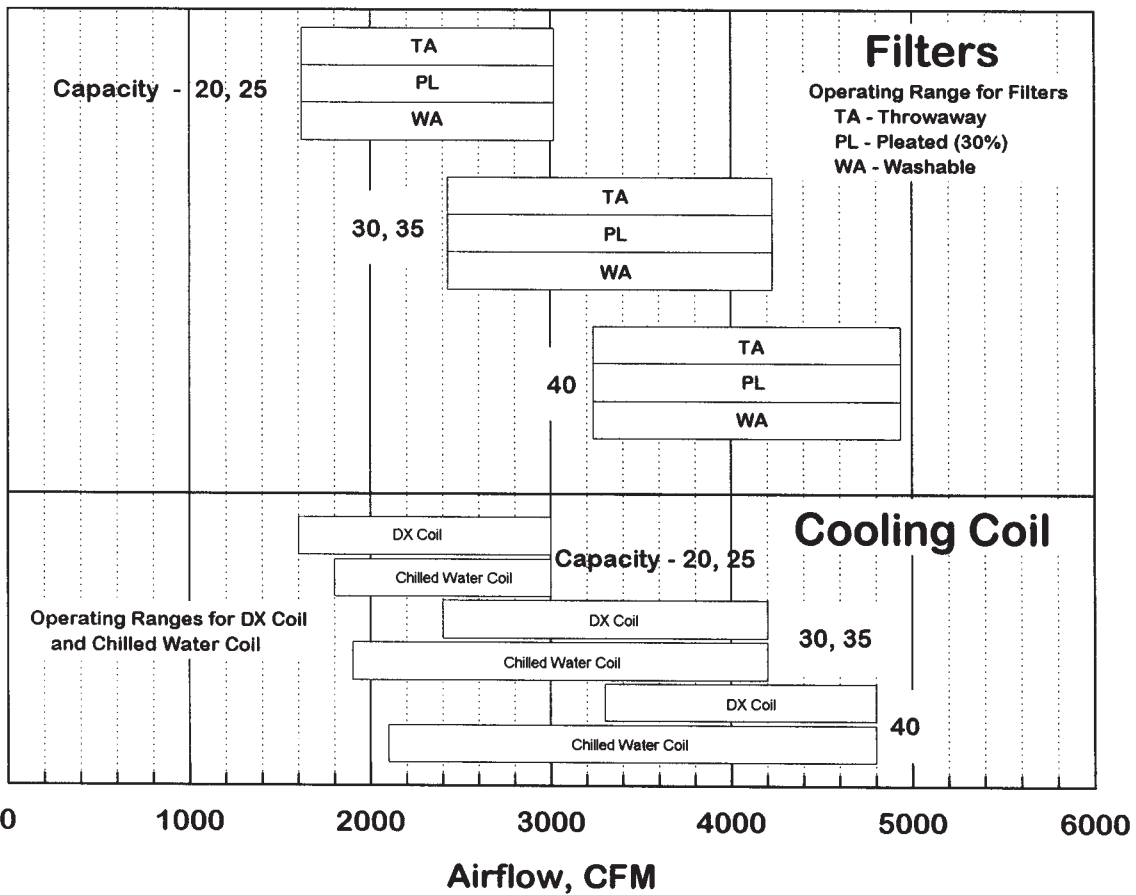
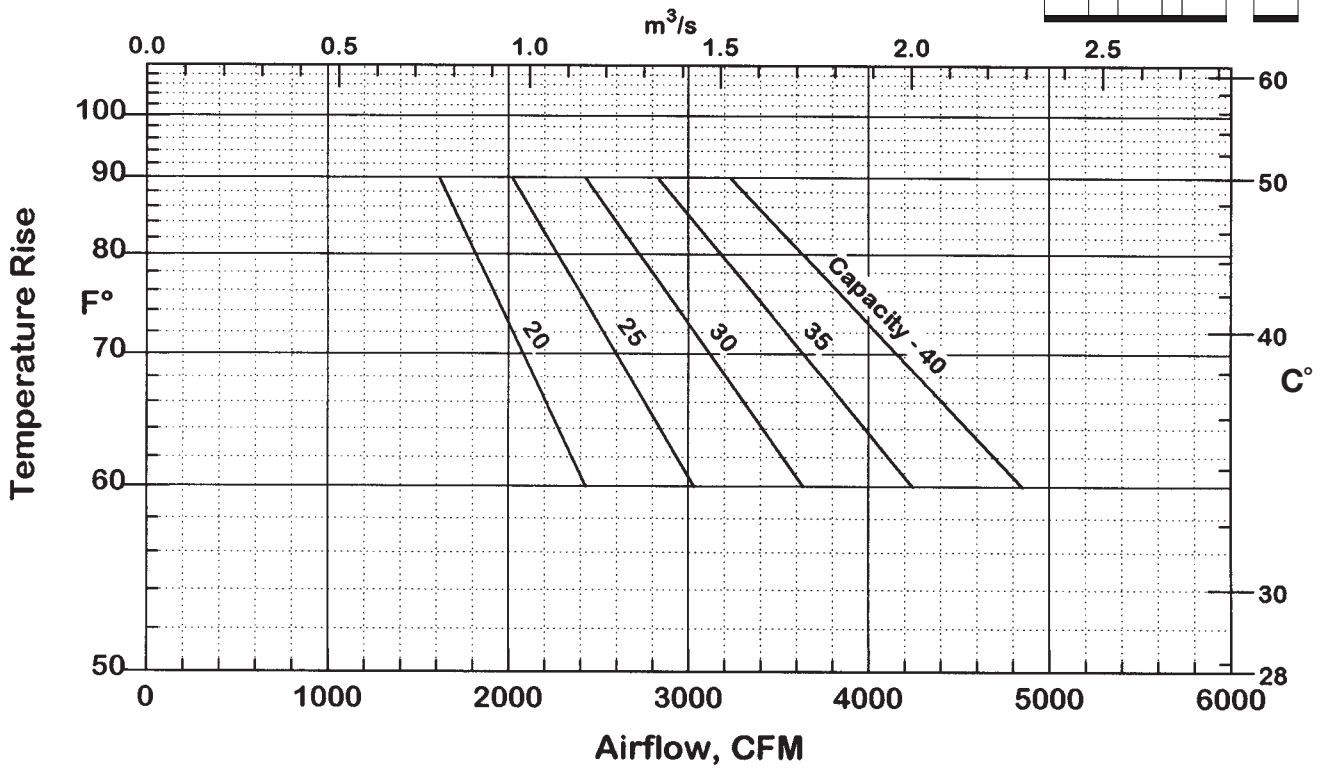

Performance – Table 5

Furnace Type - (A,B) Standard Temperature Rise Rooftop Arrangement (G,J,K,L)

The maximum CFM for Rooftop Arrangements K and L with cooling coil is 6,300 (3.0 m³/s). A two speed motor may be utilized for non-cooling air flow up to 14,000 CFM (6.6 m³/s).

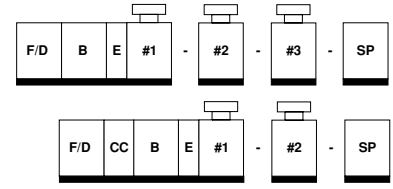

TOTAL STATIC PRESSURE (INCHES OF WATER)

Capacity Furnace Type	TR (°F)	Input CFM	Input BTU/H	Output BTU/H	0.2		0.4		0.6		0.8		1		1.2		1.4		1.6		1.8		2			
					RPM	BHP	RPM	BHP	RPM	BHP	RPM	BHP	RPM	BHP	RPM	BHP	RPM	BHP	RPM	BHP	RPM	BHP	RPM	BHP	RPM	BHP
*10-A,B	61	1,200	100,000	80,000	575	.16	705	.23	825	.31	940	.40	1040	.50	1135	.60	1220	.70	1300	.80	1375	.91	1440	1.02	1460	1.04
	49	1,500			655	.26	765	.35	870	.44	965	.54	1060	.64	1150	.75	1235	.87	1315	.99	1390	1.12	1460	1.24	1490	1.68
	37	2,000			795	.55	890	.65	975	.77	1055	.88	1130	1.00	1205	1.12	1280	1.25	1355	1.39	1425	1.54	1545	1.68	1545	2.29
	29	2,500			950	1.01	1030	1.12	1105	1.25	1175	1.39	1240	1.54	1305	1.68	1365	1.83	1425	1.98	1485	2.13	1545	2.29	1545	3.14
	25	3,000			1110	1.68	1175	1.82	1240	1.95	1305	2.10	1365	2.27	1420	2.44	1475	2.62	1530	2.79	1580	2.97	1635	3.14	1635	4.25
*15-A,B	55	2,000	150,000	120,000	685	.44	785	.54	880	.63	965	.75	1045	.87	1120	.98	1195	1.11	1270	1.24	1345	1.37	1415	1.52	1440	2.01
	44	2,500			805	.78	890	.91	970	1.04	1045	1.15	1120	1.28	1190	1.43	1255	1.57	1320	1.72	1380	1.86	1440	2.01	1500	2.70
	37	3,000			935	1.00	1005	1.14	1075	1.30	1140	1.45	1205	1.68	1270	1.88	1335	2.18	1390	2.35	1450	2.53	1500	2.70	1580	3.55
	32	3,500			1065	1.97	1130	2.15	1190	2.33	1250	2.52	1305	2.70	1360	2.87	1420	3.02	1475	3.17	1525	3.35	1580	3.55	1580	4.65
	28	4,000			1200	2.88	1255	3.08	1310	3.28	1365	3.49	1415	3.70	1465	3.91	1515	4.12	1565	4.30	1615	4.48	1660	4.65	1660	6.06
20-A,B	59	2,500	200,000	160,000	425	.36	495	.46	565	.55	635	.67	700	.80	760	.93	820	1.07	875	1.21	925	1.35	975	1.50	975	1.84
	49	3,000			490	.59	540	.68	600	.80	660	.92	720	1.05	775	1.19	830	1.35	885	1.51	930	1.67	980	1.84	1005	2.68
	37	4,000			630	1.30	660	1.41	700	1.54	740	1.68	785	1.84	830	2.00	875	2.16	920	2.32	965	2.49	1005	2.68	1065	4.02
	29	5,000			770	2.46	795	2.59	825	2.73	850	2.88	880	3.05	915	3.24	950	3.43	990	3.63	1025	3.83	1065	4.02	1140	5.90
	25	6,000			915	4.18	940	4.34	960	4.50	980	4.66	1000	4.84	1025	5.02	1050	5.23	1080	5.44	1110	5.67	1140	5.90	1185	7.06
25-A,B	60	3,000	300,000	240,000	415	.47	505	.65	590	.86	665	1.08	740	1.33	815	1.60	885	1.89	950	2.19	1010	2.51	1065	2.82	1065	3.46
	55	4,000			430	.56	520	.76	600	.97	675	1.20	745	1.45	815	1.72	880	2.02	945	2.33	1005	2.65	1065	2.99	1065	4.40
	37	6,000			560	1.51	630	1.79	690	2.08	750	2.38	805	2.69	860	3.01	910	3.34	960	3.68	1010	4.03	1055	4.40	1115	5.72
	28	8,000			710	3.29	760	3.64	810	4.01	860	4.40	905	4.79	950	5.19	995	5.6	1035	5.99	1075	6.41	1115	6.83	1210	10.42
	22	10,000			860	6.18	900	6.59	945	7.03	985	7.48	1025	7.95	1065	8.44	1100	8.93	1140	9.42	1175	9.92	1210	10.42	1260	12.70
35-A,B	57	4,500	350,000	280,000	405	.58	490	.76	565	.96	640	1.19	705	1.43	765	1.68	825	1.93	885	2.19	930	2.46	975	2.74	975	3.75
	43	6,000			500	1.22	555	1.43	615	1.66	675	1.90	735	2.16	790	2.46	845	2.78	895	3.10	945	3.43	990	3.75	1025	5.55
	32	8,000			645	2.70	675	2.93	715	3.20	760	3.51	805	3.83	850	4.14	895	4.45	940	4.79	985	5.15	1025	5.55	1085	8.31
	26	10,000			790	5.10	815	5.37	840	5.67	870	5.99	905	6.35	940	6.74	980	7.14	1015	7.53	1050	7.92	1085	8.31	1170	12.27
	22	12,000			935	8.66	960	8.98	980	9.31	1000	9.66	1025	10.04	1050	10.44	1080	10.87	1110	11.32	1140	11.79	1170	12.27	1215	14.69
40-A,B	59	5,000	400,000	320,000	430	.73	500	.92	570	1.12	640	1.35	705	1.61	765	1.88	820	2.15	875	2.43	925	2.71	975	3.00	975	4.00
	49	6,000			495	1.18	545	1.38	605	1.62	665	1.85	725	2.11	780	2.40	835	2.72	885	3.04	935	3.36	985	3.69	1010	5.41
	37	8,000			630	2.62	665	2.85	700	3.10	745	3.40	790	3.72	835	4.03	880	4.34	925	4.67	970	5.02	1010	5.41	1070	8.11
	29	10,000			775	4.96	800	5.23	825	5.51	855	5.82	885	6.16	920	6.54	960	6.93	995	7.33	1030	7.72	1070	8.11	1145	11.92
	25	12,000			920	8.42	945	8.74	965	9.07	985	9.40	1010	9.75	1030	10.14	1060	10.55	1085	10.98	1115	11.44	1145	11.92	1215	14.69
50-A,B	57	3,100	500,000	400,000	515	.66	565	.76	625	.89	680	1.01	740	1.14	790	1.29	845	1.45	895	1.61	945	1.78	990	1.95	990	2.97
	92	4,000			640	1.34	675	1.45	715	1.59	755	1.74	805	1.90	850	2.06	895	2.21	935	2.38	980	2.56	1020	2.76	1020	3.16
	74	5,000			785	2.54	810	2.67	840	2.82	870	2.98	900	3.16	935	3.35	975	3.55	1010	3.74	1045	3.94	1085	4.13	1110	4.83
	61	6,000			935	4.30	955	4.46	975	4.63	1000	4.80	1020	4.98	1045	5.18	1075	5.4	1105	5.62	1135	5.86	1165	6.10	1265	8.68
	53	7,000			1080	6.76	1100	6.94	1120	7.13	1135	7.32	1155	7.52	1175	7.73	1195	7.95	1215	8.18	1240	8.42	1265	8.68	1265	11.92
60-A,B	49	7,500	600,000	480,000	1155	8.28	1175	8.48	1190	8.68	1205	8.88	1225	9.08	1240	9.30	1260	9.52	1280	9.76	1305	10.05	1335	10.35	1335	14.69
	120	3,700			455	.55	545	.74	625	.95	700	1.19	775	1.45	845	1.73	915	2.02	975	2.33	1035	2.65	1090	2.97	1090	3.16
	111	4,000			480	.66	560	.86	640	1.09	710	1.33	780	1.59	850	1.87	915	2.18	975	2.50	1035	2.83	1090	3.16	1110	4.83
	74	6,000			640	1.83	700	2.12	755	2.42	810	2.73	865	3.05	915	3.38	965	3.72	1015	4.08	1065	4.45	1110	4.83	1110	7.68
	55	8,000			810	4.00	855	4.38	905	4.78	950	5.17	990	5.57	1035	5.98	1075	6.39	1115	6.81	1155	7.24	1195	7.68	1195	11.95
44	10,000			985	7.49	1025	7.96	1065	8.45	1100	8.94	1140	9.43	1175	9.92	1210	10.42	1245	10.93	1280	11.43	1310	11.95	1310	14.69	
40	11,000			1075	9.83	1110	10.35	1145	10.87	1180	11.41	1215	11.95	1250	12.49	1280	13.04	1315	13.58	1358	14.14	1375	14.69	1375	14.69	

Performance – Table 6

Furnace Type - (C,D) High Temperature Rise Rooftop Arrangement (K,L)

Table 5 continued



Capacity Furnace Type	Input		0.2		0.4		0.6		0.8		1		1.4		1.6		1.8		RPM	BHP	RPM	BHP		
	CFM	BTU/H	RPM	BHP	RPM	BHP	RPM	BHP	RPM	BHP	RPM	BHP	RPM	BHP	RPM	BHP	RPM	BHP						
115	4,500	700,000	560,000	445	.67	525	.85	600	1.07	670	1.31	735	1.55	795	1.80	850	2.06	905	2.32	955	2.60	1000	2.88	
86	6,000			545	1.39	610	1.63	670	1.86	725	2.12	780	2.42	835	2.73	890	3.05	940	3.38	985	3.71	1030	4.04	
70-A,B	65	8,000		695	3.06	735	3.35	785	3.66	830	3.98	875	4.29	920	4.61	960	4.96	1005	5.34	1045	5.74	1085	6.16	
	52	10,000		850	5.75	880	6.09	915	6.46	950	6.85	990	7.25	1025	7.64	1060	8.03	1095	8.42	1130	8.82	1165	9.23	
	43	12,000		1005	9.74	1030	10.13	1060	10.54	1085	10.97	1115	11.43	1145	11.90	1175	12.38	1210	12.86	1240	13.33	1270	13.79	
	40	13,000		1085	12.30	1110	12.71	1130	13.14	1155	13.59	1185	14.08	1210	14.57	-	-	-	-	-	-	-	-	
	118	5,000	800,000	640,000	460	.82	535	1.01	605	1.22	670	1.47	735	1.74	790	2.01	850	2.28	900	2.56	950	2.85	995	3.14
	98	6,000			525	1.31	585	1.54	645	1.77	705	2.02	760	2.30	815	2.61	870	2.93	920	3.25	965	3.58	1015	3.91
80-A,B	74	8,000		670	2.88	710	3.15	750	3.45	800	3.77	845	4.08	890	4.39	935	4.72	975	5.08	1020	5.47	1060	5.88	
	59	10,000		820	5.45	850	5.75	880	6.08	915	6.45	950	6.84	985	7.24	1025	7.63	1060	8.02	1095	8.41	1130	8.81	
	49	12,000		975	9.24	995	9.58	1020	9.95	1045	10.35	1075	10.77	1100	11.22	1130	11.69	1165	12.17	1195	12.65	1225	13.12	
	44	13,500		1090	13.03	1110	13.41	1130	13.8	1150	14.23	1175	14.68	-	-	-	-	-	-	-	-	-	-	
	161	5,500	1,200,000	960,000	530	1.16	595	1.38	660	1.61	720	1.87	780	2.17	835	2.46	885	2.76	935	3.06	985	3.37	1030	3.68
	147	6,000			565	1.46	625	1.70	685	1.93	740	2.20	800	2.50	850	2.82	905	3.15	950	3.47	1000	3.80	1045	4.13
	126	7,000		640	2.21	690	2.49	745	2.76	795	3.03	845	3.34	890	3.68	940	4.04	985	4.41	1030	4.79	1070	5.16	
12-A,B	111	8,000		715	3.20	760	3.50	805	3.82	850	4.13	895	4.45	940	4.78	980	5.14	1025	5.54	1065	5.95	1105	6.37	
	88	10,000		875	6.01	905	6.37	940	6.75	980	7.15	1015	7.55	1050	7.94	1090	8.32	1125	8.72	1160	9.13	1195	9.57	
	74	12,000		1035	10.16	1060	10.57	1090	11.01	1120	11.47	1150	11.94	1180	12.42	1210	12.90	1240	13.36	1270	13.83	1300	14.29	
	68	13,000		1115	12.81	1140	13.25	1165	13.72	1190	14.20	1220	14.71	-	-	-	-	-	-	-	-	-	-	

*Capacity - 10, 15 units when equipped with Cooling Only, (Rooftop Arrangements B, C) for Capacity - 10, 15 units Without Cooling. See Table 6 below for notes.

Performance – Table 6

TOTAL STATIC PRESSURE (INCHES OF WATER)

Capacity Furnace Type	Input		0.2		0.4		0.6		0.8		1		1.4		1.6		1.8		RPM	BHP	RPM	BHP
	CFM	BTU/H	RPM	BHP	RPM	BHP	RPM	BHP	RPM	BHP	RPM	BHP	RPM	BHP	RPM	BHP	RPM	BHP				
20-C,D	81	1,800	400	.20	495	.29	580	.39	650	.49	720	.59	780	.70	835	.82	890	.94	940	1.07	985	1.20
	73	2,000	425	.26	510	.35	590	.45	665	.56	730	.67	790	.79	845	.91	900	1.04	950	1.17	995	1.31
	66	2,200	450	.33	530	.42	605	.53	675	.64	740	.76	800	.89	855	1.02	915	1.15	955	1.28	1000	1.43
	61	2,400	475	.40	550	.50	620	.61	690	.74	750	.87	810	1.00	865	1.13	915	1.27	965	1.41	1010	1.56
	91	2,000	405	.24	495	.33	575	.43	650	.54	715	.65	785	.76	835	.89	890	1.01	940	1.14	985	1.28
	84	2,200	435	.32	515	.41	590	.52	660	.64	725	.76	785	.88	845	1.01	895	1.14	945	1.28	995	1.42
25-C,D	73	2,500	465	.42	540	.52	610	.62	675	.75	740	.88	795	1.02	855	1.15	905	1.29	955	1.44	1000	1.58
	66	2,750	500	.53	565	.64	630	.75	695	.87	755	1.02	810	1.16	865	1.31	915	1.46	965	1.62	1010	1.77
	61	3,000	535	.67	595	.79	655	.90	710	1.03	770	1.17	825	1.33	875	1.49	925	1.65	975	1.81	1020	1.98
	91	2,400	300,000	237,000	390	.25	510	.40	615	.60	700	.80	775	1.01	845	1.23	905	1.45	960	1.68	1010	1.92
	84	2,600	405	.29	515	.45	615	.65	705	.86	780	1.09	850	1.31	910	1.55	965	1.79	1020	2.04	1065	2.29
	78	2,800	420	.33	520	.50	620	.70	710	.92	785	1.16	855	1.40	920	1.65	975	1.91	1025	2.16	1075	2.43
30-C,D	73	3,000	435	.38	530	.56	625	.76	710	.99	790	1.24	860	1.49	925	1.76	980	2.02	1035	2.29	1085	2.57
	68	3,200	450	.44	540	.62	630	.83	715	1.06	790	1.32	865	1.59	930	1.86	985	2.14	1040	2.42	1090	2.71
	64	3,400	465	.51	555	.69	640	.91	720	1.14	795	1.40	865	1.68	930	1.97	990	2.26	1045	2.56	1100	2.86
	61	3,600	480	.58	565	.77	645	.99	725	1.23	800	1.49	870	1.78	935	2.08	995	2.38	1050	2.69	1105	3.00
	85	3,000	350,000	276,500	385	.29	485	.46	575	.62	650	.81	715	1.00	775	1.21	835	1.44	885	1.67	935	1.90
	80	3,200	395	.34	495	.50	580	.68	655	.87	720	1.07	780	1.29	840	1.51	890	1.75	940	2.00	985	2.25
35-C,D	75	3,400	410	.38	505	.56	585	.74	660	.94	725	1.14	785	1.36	840	1.60	895	1.84	945	2.09	990	2.35
	67	3,800	430	.49	520	.68	600	.88	670	1.09	735	1.31	795	1.54	855	1.78	905	2.03	955	2.29	1000	2.57
	64	4,000	445	.55	530	.74	610	.96	680	1.17	745	1.40	805	1.63	860	1.88	910	2.14	960	2.41	1005	2.68
	61	4,200	460	.62	540	.81	615	1.04	685	1.26	750	1.50	810	1.74	865	1.99	915	2.25	965	2.52	1010	2.81
	88	3,500	400,000	316,000	390	.34	485	.51	575	.69	650	.88	715	1.08	775	1.30	835	1.52	885	1.76	935	2.01
	83	3,500	400	.38	495	.56	580	.75	655	.94	720	1.15	780	1.37	835	1.60	890	1.85	940	2.10	985	2.37
40-C,D	73	4,000	430	.52	515	.70	595	.92	665	1.13	730	1.36	790	1.59	850	1.83	900	2.09	950	2.35	995	2.63
	65	4,500	460	.70	540	.88	615	1.11	680	1.35	745	1.58	805	1.85	860	2.10	910	2.37	960	2.65	1005	2.93
	58	5,000	495	.91	565	1.11	635	1.34	700	1.60	760	1.87	820	2.14	875	2.41	925	2.70	975	2.99	1020	3.29

Notes: 1. Refer to Table 4 for Accessory Pressure Losses.
 2. Values in Tables 2 and 3 are based on the "Basic Packaged Unit" which includes pressure drop of the Duct Furnace(s) and "system effect" of the Blower Module.
 3. Brake Horsepower (BHP) includes drive losses.
 4. Unit leaving air temperature is limited to 150° F (66° C) and is equal to: Entering Air Temperature + Duct Furnace(s) Temperature Rise.
 5. "Total Static Pressure" is the sum of the unit's "Internal" accessory pressure loss(es) from Table 4, plus the external static pressure.

6. Ratings shown are for elevations between 0 and 2000 ft. (610 m). For unit installations in the U.S.A. above 2000 ft. (610 m), the unit input must be derated 4% for each 1000 ft. (305 m) above sea level, refer to local codes, or in the absence of local codes, refer to the National Fuel Gas Code, ANSI Standard Z223.1-1992 (NFPA, No. 54), or the latest edition of:

For installations in Canada, any references to derating at altitudes in excess of 2000 ft. (610m) are to be ignored. At altitudes of 2000 to 4500 ft. (610 to 1372m), the unit must be derated to 90% of the normal rating, and be so marked in accordance with the C.G.A. certification.

ARRANGEMENTS



Accessory Pressure Loss – Table 7

Rooftop Arrangement (G,J,K,L) - (S,T,U,W)

F/D	B	E
-----	---	---

F/D	CC	B	E
-----	----	---	---

PRESSURE LOSS (INCHES OF WATER)

Capacity	CFM	RAINHOOD		FILTERS						Supply Air Plenum	Return or Outside Air Damper
		With		Throwaway		Washable		Pleated			
		Screen	Mstr.Elim.	2"	1"	2"	1"	2"			
10	800	<.01	.01	.01	<.01	<.01	<.01	<.01	<.01	.02	.01
	900	.01	.02	.01	<.01	<.01	<.01	<.01	<.01	.02	.02
	1,100	.02	.02	.02	<.01	<.01	<.01	.01	<.01	.03	.03
	1,200	.02	.03	.02	<.01	<.01	<.01	.02	<.01	.04	.03
	1,500	.03	.04	.02	<.01	<.01	<.01	.02	.01	.06	.05
	2,000	.06	.07	.04	<.01	<.01	<.01	.04	.02	.10	.09
	2,500	.09	.12	.05	<.01	.01	.05	.05	.03	.15	.13
	3,000	.13	.17	.06	.01	.02	.07	.07	.04	.22	.19
	3,500	.18	.23	.08	.01	.02	.09	.09	.05	.29	.25
15	1,200	.02	.03	.02	<.01	<.01	.02	<.01	.03	.03	.03
	1,400	.03	.04	.02	<.01	<.01	.02	<.01	.03	.03	.04
	1,600	.04	.05	.03	<.01	<.01	.03	.01	.04	.04	.06
	1,800	.05	.06	.03	<.01	<.01	.03	.02	.06	.06	.07
	2,000	.06	.07	.04	<.01	<.01	.04	.02	.07	.07	.09
	2,500	.09	.12	.05	<.01	.01	.05	.03	.11	.11	.13
	3,000	.13	.17	.06	.01	.02	.07	.04	.15	.15	.19
	3,500	.18	.23	.08	.01	.02	.09	.05	.21	.21	.25
	4,000	.23	.30	.09	.02	.03	.12	.07	.27	.27	.33
4,500	.29	.38	.11	.02	.03	.14	.08	.34	.34	.42	
20	1,600	.02	.02	.03	<.01	<.01	.03	.01	.02	.03	.03
	1,800	.02	.03	.03	<.01	<.01	.03	.02	.03	.03	.03
	2,000	.02	.03	.04	<.01	<.01	.04	.02	.03	.03	.04
	2,200	.03	.04	.04	<.01	<.01	.04	.02	.04	.04	.05
	2,400	.03	.05	.05	<.01	<.01	.05	.03	.05	.05	.05
	2,500	.04	.05	.05	<.01	.01	.05	.03	.05	.05	.06
	3,000	.05	.07	.06	.01	.02	.07	.04	.07	.07	.08
	4,000	.09	.13	.09	.02	.03	.12	.07	.13	.13	.15
	5,000	.15	.20	.12	.03	.04	.17	.10	.21	.21	.23
	6,000	.21	.29	.16	.04	.06	.23	.14	.30	.30	.33
6,500	.25	.34	.17	.05	.07	.26	.16	.35	.35	.39	
7,000	.29	.40	.19	.06	.08	.30	.18	.40	.40	.45	
7,400	.32	.45	-	.06	.09	.33	.20	.45	.45	.50	
25	2,000	.02	.03	.04	<.01	<.01	.04	.02	.02	.03	.04
	2,250	.03	.04	.04	<.01	<.01	.04	.02	.03	.03	.05
	2,500	.04	.05	.05	<.01	.01	.05	.03	.04	.04	.06
	2,750	.04	.06	.05	<.01	.01	.06	.03	.04	.04	.07
	3,000	.05	.07	.06	.01	.02	.07	.04	.05	.05	.08
	4,000	.09	.13	.09	.02	.03	.12	.07	.09	.09	.15
	5,000	.15	.20	.12	.03	.04	.17	.10	.14	.14	.23
	6,000	.21	.29	.16	.04	.06	.23	.14	.21	.21	.33
	7,000	.29	.40	.19	.06	.08	.30	.18	.28	.28	.45
7,500	.33	.46	-	.07	.09	.34	.21	.32	.32	.52	
30	2,400	.02	.03	.02	<.01	<.01	.02	.01	.02	.03	.03
	2,600	.02	.03	.03	<.01	<.01	.03	.01	.03	.03	.04
	2,800	.03	.04	.03	<.01	<.01	.03	.01	.03	.03	.04
	3,000	.03	.04	.03	<.01	<.01	.03	.02	.03	.03	.05
	3,200	.03	.05	.03	<.01	<.01	.04	.02	.04	.04	.05
	3,400	.04	.06	.04	<.01	<.01	.04	.02	.04	.04	.06
	3,600	.04	.06	.04	<.01	<.01	.04	.02	.05	.05	.07
	4,000	.05	.08	.05	<.01	.01	.05	.03	.06	.06	.08
	6,000	.12	.17	.08	.02	.02	.10	.06	.13	.13	.19
	8,000	.22	.31	.12	.03	.04	.17	.10	.24	.24	.33
	10,000	.34	.48	.16	.04	.06	.24	.14	.37	.37	.52
11,000	.41	.58	.18	.05	.08	.28	.17	.45	.45	.63	

Note: Refer to Tables 8A & 8B for DX Cooling Coil and Tables 9A & 9B for Chilled Water Coil Pressure Losses (Rooftop Arrangements K,L).

Accessory Pressure Loss – Table 7 *continued*

Rooftop Arrangement (G,J,K,L) - (S,T,U,W)

PRESSURE LOSS (INCHES OF WATER) *continued*

Capacity	CFM	RAINHOOD		FILTERS				Supply Air Plenum	Return or Outside Air Damper	
		With		Throwaway		Washable				
		Screen	Mstr.Elim.	2"	1"	2"	1"			Pleated
35	3,000	.03	.04	.03	<.01	<.01	.03	.02	.03	.05
	3,200	.03	.05	.03	<.01	<.01	.04	.02	.03	.05
	3,400	.04	.06	.04	<.01	<.01	.04	.02	.04	.06
	3,600	.04	.06	.04	<.01	<.01	.04	.02	.04	.07
	3,800	.05	.07	.04	<.01	<.01	.05	.03	.04	.08
	4,000	.05	.08	.05	<.01	.01	.05	.03	.05	.08
	4,500	.07	.10	.05	<.01	.01	.06	.03	.06	.11
	6,000	.12	.17	.08	.02	.02	.10	.06	.11	.19
	8,000	.22	.31	.12	.03	.04	.17	.10	.19	.33
	10,000	.34	.48	.16	.04	.06	.24	.14	.30	.52
	12,000	.49	.69	-	.06	.09	.33	.20	.43	.75
	13,000	.58	.81	-	.07	.11	.38	.23	.51	.88
	40	3,300	.03	.04	.03	<.01	<.01	.03	.02	.03
3,500		.03	.05	.03	<.01	<.01	.03	.02	.03	.05
4,000		.04	.06	.04	<.01	<.01	.04	.02	.04	.07
4,500		.05	.08	.05	<.01	<.01	.05	.03	.05	.08
5,000		.07	.10	.05	<.01	.01	.06	.03	.06	.10
6,000		.10	.14	.07	.01	.02	.08	.04	.08	.15
8,000		.17	.24	.10	.02	.03	.13	.07	.15	.26
10,000		.27	.38	.13	.03	.05	.19	.11	.23	.41
12,000		.39	.55	.17	.05	.07	.26	.16	.34	.59
14,000		.53	.75	-	.07	.09	.33	.21	.46	.80
50	3,100	.06	.08	.06	.01	.02	.08	.04	.06	.09
	4,000	.09	.13	.09	.02	.03	.12	.07	.09	.15
	5,000	.15	.20	.12	.03	.04	.17	.10	.14	.23
	6,000	.21	.29	.16	.04	.06	.23	.14	.21	.33
	7,000	.29	.40	.19	.06	.08	.30	.18	.28	.45
	7,500	.33	.46	-	.07	.09	.34	.21	.32	.52
60	3,700	.05	.07	.04	<.01	<.01	.05	.02	.05	.07
	4,000	.05	.08	.05	<.01	.01	.05	.03	.06	.08
	6,000	.12	.17	.08	.02	.02	.10	.06	.13	.19
	8,000	.22	.31	.12	.03	.04	.17	.10	.24	.33
	10,000	.34	.48	.16	.04	.06	.24	.14	.37	.52
	11,000	.41	.58	.18	.05	.08	.28	.17	.45	.63
70	4,500	.07	.10	.05	<.01	.01	.06	.03	.06	.11
	6,000	.12	.17	.08	.02	.02	.10	.06	.11	.19
	8,000	.22	.31	.12	.03	.04	.17	.10	.19	.33
	10,000	.34	.48	.16	.04	.06	.24	.14	.30	.52
	12,000	.49	.69	-	.06	.09	.33	.20	.43	.75
	13,000	.58	.81	-	.07	.11	.38	.23	.51	.88
80	5,000	.07	.10	.05	<.01	.01	.06	.03	.06	.10
	6,000	.10	.14	.07	.01	.02	.08	.04	.08	.15
	8,000	.17	.24	.10	.02	.03	.13	.07	.15	.26
	10,000	.27	.38	.13	.03	.05	.19	.11	.23	.41
	12,000	.39	.55	.17	.05	.07	.26	.16	.34	.59
	13,500	.49	.70	-	.06	.09	.31	.19	.43	.75
12	7,400	.15	.21	.09	.02	.03	.11	.06	.13	.22
	8,000	.17	.24	.10	.02	.03	.13	.07	.15	.26
	10,000	.27	.38	.13	.03	.05	.19	.11	.23	.41
	12,000	.39	.55	.17	.05	.07	.26	.16	.34	.59
13,000	.46	.65	.19	.06	.08	.30	.18	.40	.69	

Note: Refer to Tables 8A & 8B for DX Cooling Coil and Tables 9A & 9B for Chilled Water Coil Pressure Losses (Rooftop Arrangements K,L).



Dimensional Data – Unit Modules

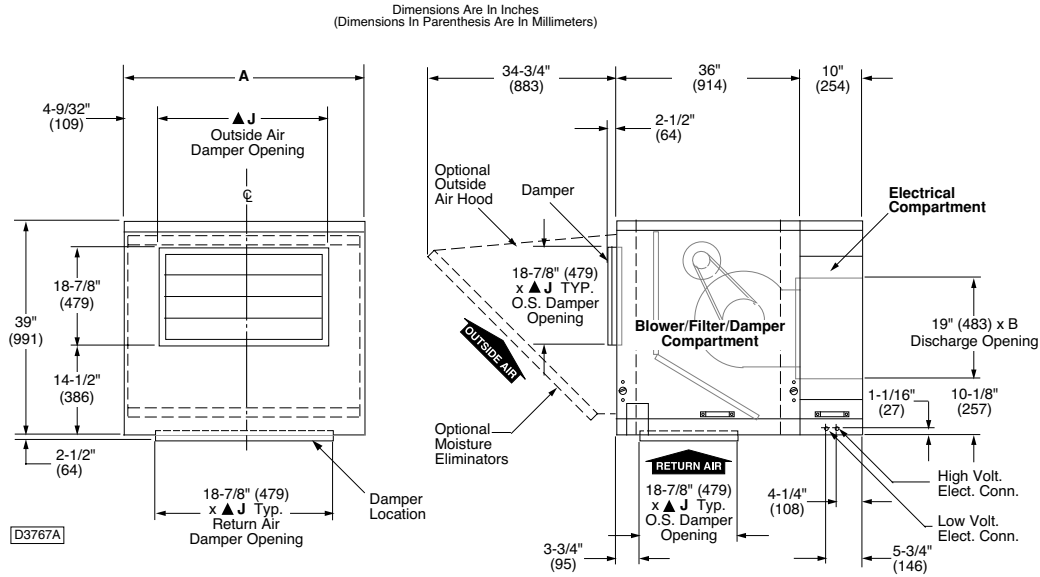

MODEL	A	B	▲ J
10/15	32-7/8" (835)	15-9/16" (395)	24" (610)
20/25/50	43-7/8" (1114)	23-13/16" (605)	35" (889)
30/35 60/70	54-7/8" (1394)	34-13/16" (884)	46" (1168)
40/80	60-3/4" (1534)	45-13/16" (1164)	51-1/2" (1308)

Standard Blower Module† Rooftop Arrangements [RA] “B,C,D,E” Capacities [CA] 10 - 80 Unit Sizes (Right hand service access shown)

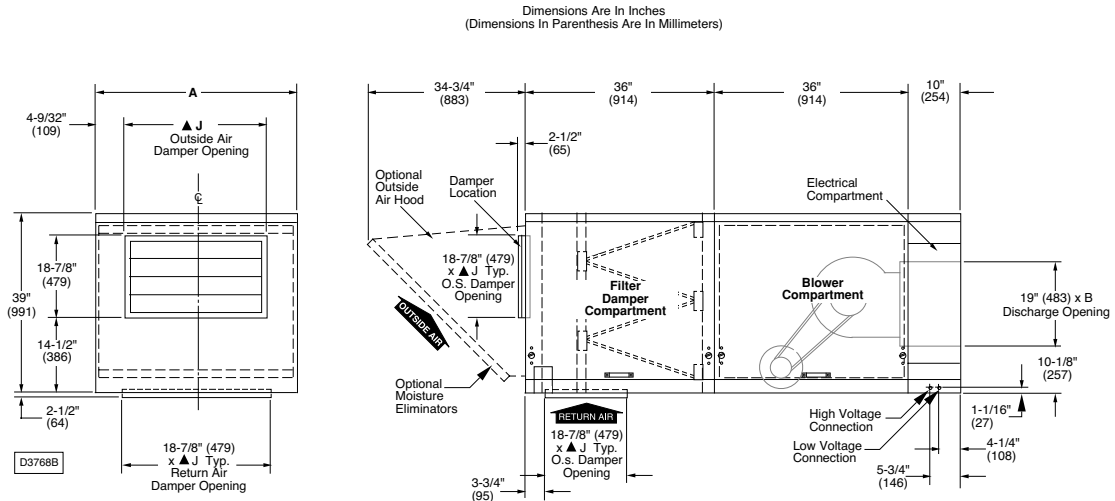

High CFM Blower Module*† Rooftop Arrangements [RA] “G, J” Capacities [CA] 10 - 12

*Capacities [CA] 10 & 15 apply to cooling arrangements K and L only. Arrangements K & L are similar with the exception that the cooling coil module is located between the filter and blower compartments (see pages 28, 33 & 34).

†These dimensions shown do not include the base/skid rail.

Dimensional Data – Unit Modules

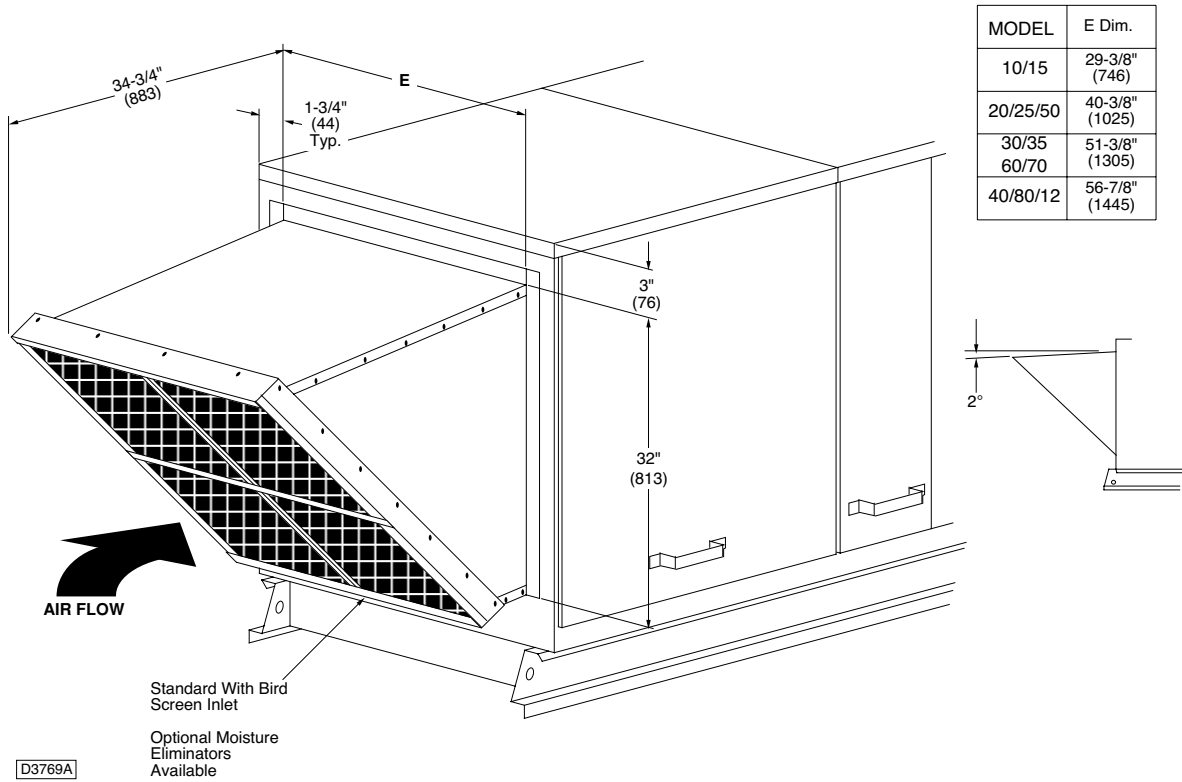

Air Intake Hood

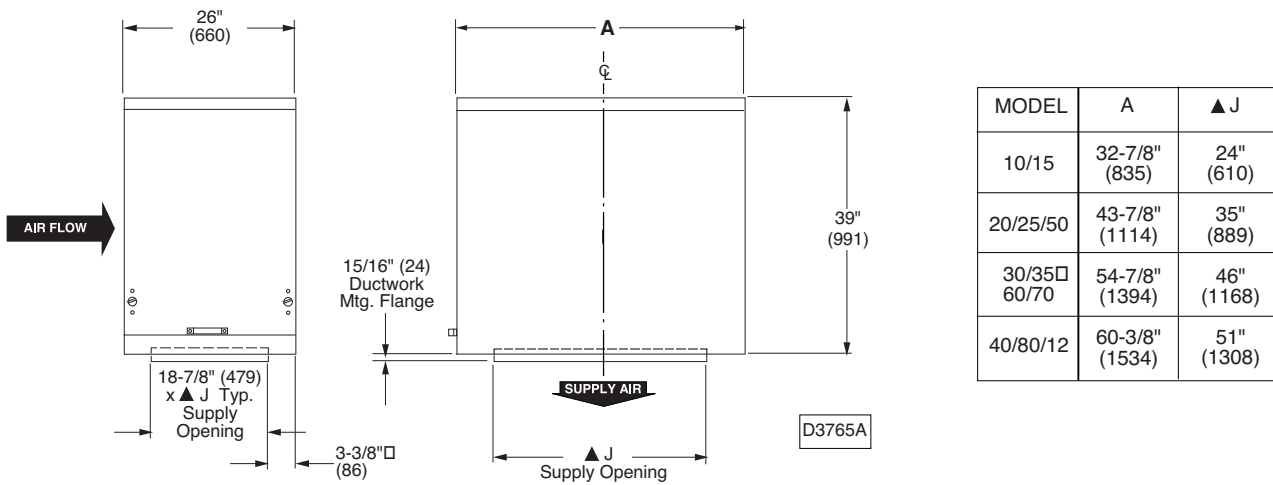

Dimensions Are In Inches
(Dimensions In Parenthesis Are In Millimeters)

Supply Plenum Module†

Capacities [CA] 10 - 12 Unit Sizes
(Right hand service access shown)

†These dimensions shown do not include the base/skid rail.

Dimensional Data – Unit Modules

Dimensions Are In Inches
(Dimensions In Parenthesis Are In Millimeters)

Model	A
10/15	32-7/8" (835)
20/25/50	43-7/8" (1114)
30/35 60/70	54-7/8" (1394)
40/80	60-3/8" (1534)

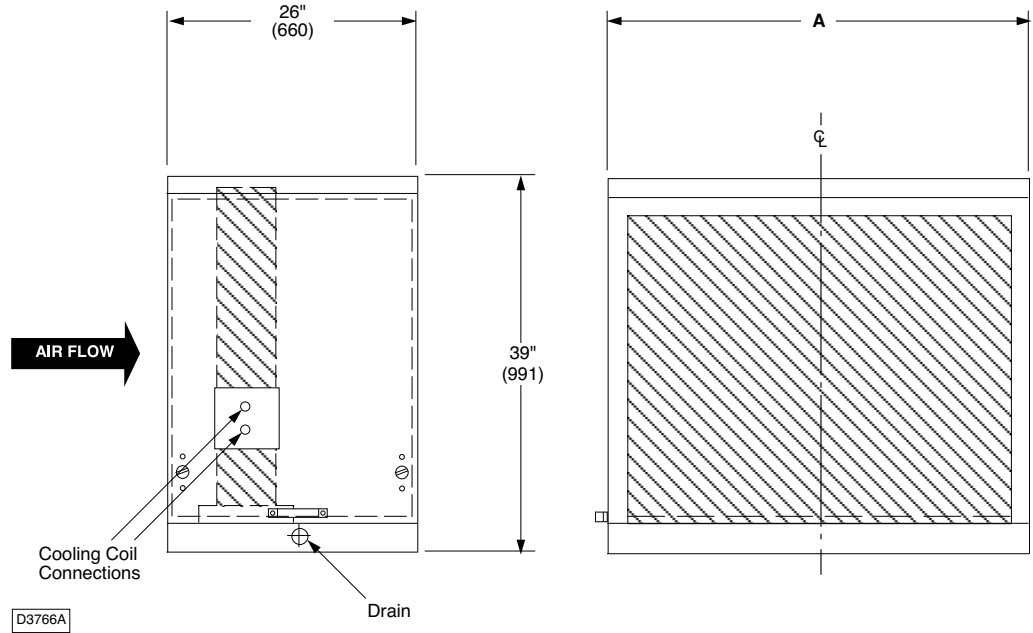

Coil Cabinet Module†
Capacities [CA] 10 - 80 Unit Sizes
(Right hand service access shown)

†These dimensions shown do not include the base/skid rail.

MODEL	A
10/15	32-7/8" (835)
20/25/50	43-7/8" (1114)
30/35 60/70	54-7/8" (1394)
40/80	60-3/8" (1534)

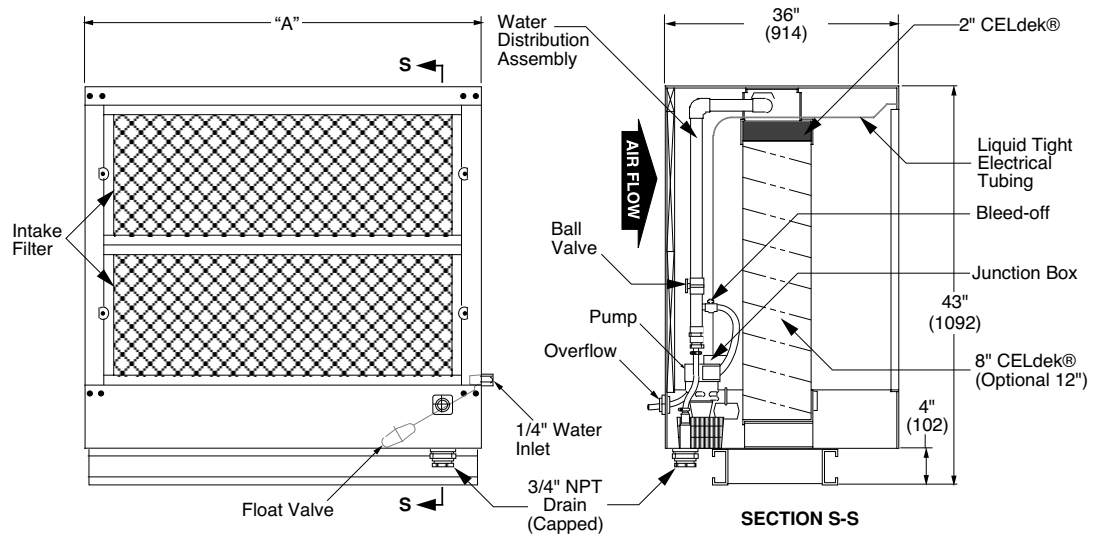

Evaporative Cooler Module
Capacities [CA] 10 - 80 Unit Sizes

Dimensional Data – Arrangements

All arrangements shown are Natural Vent.

Contact Customer Service for Power Vented Unit Submittal Sheets.

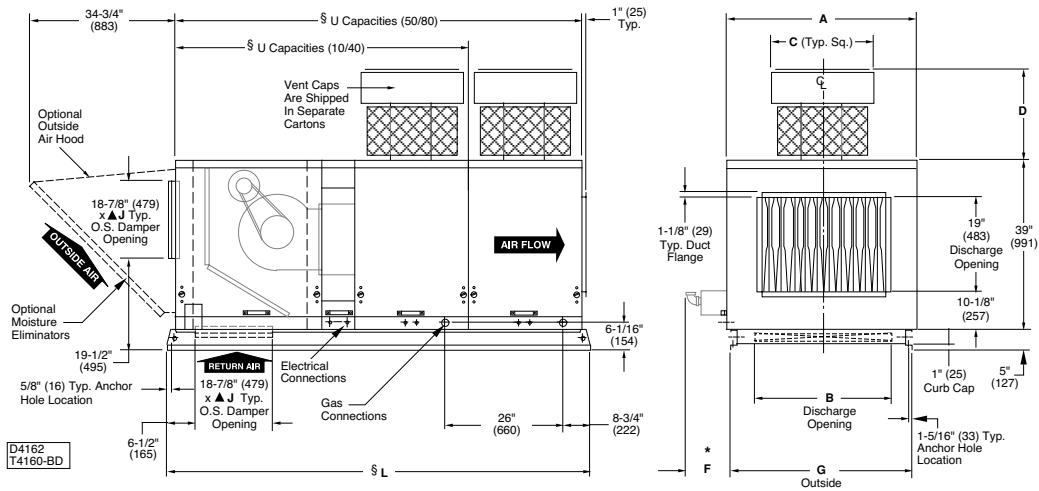

Rooftop Arrangement [RA] "B"

Capacities [CA] 10 - 80 Unit Sizes (Capacity 50 - 80 shown)

Capacity (CA)	A	B	C	D AGA	D CGA	*F	G	▲J	L	§U	NAT	Gas Inlet LP
10	32- 7/8 (835)	15- 9/16 (395)	12 (305)	11 (279)	20-11/16 (525)	19- 3/8 (492)	31- 1/16 (789)	24 (610)	77- 3/8 (1965)	72- 1/4 (1835)	1/2	1/2
15	32- 7/8 (835)	18- 5/16 (465)	21- 1/2 (546)	16 (406)	25- 3/16 (640)	23- 1/2 (597)	31- 1/16 (789)	24 (610)	77- 3/8 (1965)	72- 1/4 (1835)	1/2	1/2
20	43- 7/8 (1114)	23-13/16 (605)	23- 1/2 (597)	16 (406)	25- 3/16 (640)	26- 1/4 (667)	42- 1/16 (1068)	35 (889)	77- 3/8 (1965)	72- 1/4 (1835)	1/2	1/2
25	43- 7/8 (1114)	29- 5/16 (745)	23- 1/2 (597)	16 (406)	25- 3/16 (640)	34- 1/2 (876)	42- 1/16 (1068)	35 (889)	77- 3/8 (1965)	72- 1/4 (1835)	3/4	1/2 OR 3/4
30	54- 7/8 (1394)	34-13/16 (884)	26 (660)	17- 1/2 (445)	26-11/16 (678)	37- 1/4 (946)	53- 1/16 (1348)	46 (1168)	77- 3/8 (1965)	72- 1/4 (1835)	3/4	1/2 OR 3/4
35	54- 7/8 (1394)	40- 5/16 (1024)	26 (660)	17- 1/2 (445)	26-11/16 (678)	45- 1/2 (1156)	53- 1/16 (1348)	46 (1168)	77- 3/8 (1965)	72- 1/4 (1835)	3/4	1/2 OR 3/4
40	60- 3/8 (1534)	45-13/16 (1164)	26 (660)	17- 1/2 (445)	26-11/16 (678)	51 (1295)	58- 9/16 (1487)	51- 1/2 (1308)	77- 3/8 (1965)	72- 1/4 (1835)	3/4	1/2 OR 3/4
50	43- 7/8 (1114)	29- 5/16 (745)	23- 1/2 (597)	16 (406)	25- 3/16 (640)	34- 1/2 (876)	42- 1/16 (1068)	35 (889)	103- 3/8 (2626)	98- 1/4 (2496)	3/4	1/2 OR 3/4
60	54- 7/8 (1394)	34-13/16 (884)	26 (660)	17- 1/2 (445)	26-11/16 (678)	37- 1/4 (946)	53- 1/16 (1348)	46 (1168)	103- 3/8 (2626)	98- 1/4 (2496)	3/4	1/2 OR 3/4
70	54- 7/8 (1394)	40- 5/16 (1024)	26 (660)	17- 1/2 (445)	26-11/16 (678)	45- 1/2 (1156)	53- 1/16 (1348)	46 (1168)	103- 3/8 (2626)	98- 1/4 (2496)	3/4	1/2 OR 3/4
80	60- 3/8 (1534)	45-13/16 (1164)	26 (660)	17- 1/2 (445)	26-11/16 (678)	51 (1295)	58- 9/16 (1487)	51- 1/2 (1308)	103- 3/8 (2626)	98- 1/4 (2496)	3/4	1/2 OR 3/4

Notes: Dimensions are in inches. Dimensions in parenthesis are in millimeters.

**"F" Dimension is the recommended clearance to service the burner drawer.

▲"J" Dimension is an outside dimension for the return air damper(s).

§ All dimensions are tabulated for Rooftop Arrangements B & D per capacities 10 through 80 accordingly (Capacities 50/80 are shown pictorially).

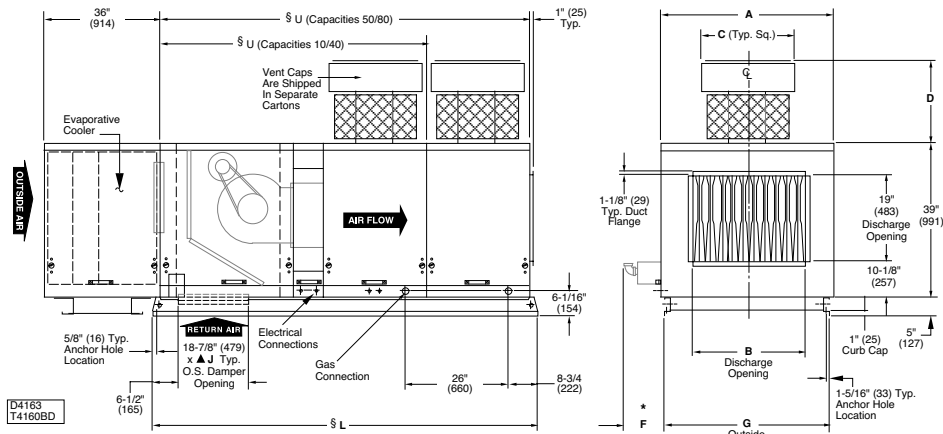

Rooftop Arrangement [RA] "D"

Capacities [CA] 10 - 80 Unit Sizes

(Capacity 50 - 80 shown)



Dimensional Data – Arrangements

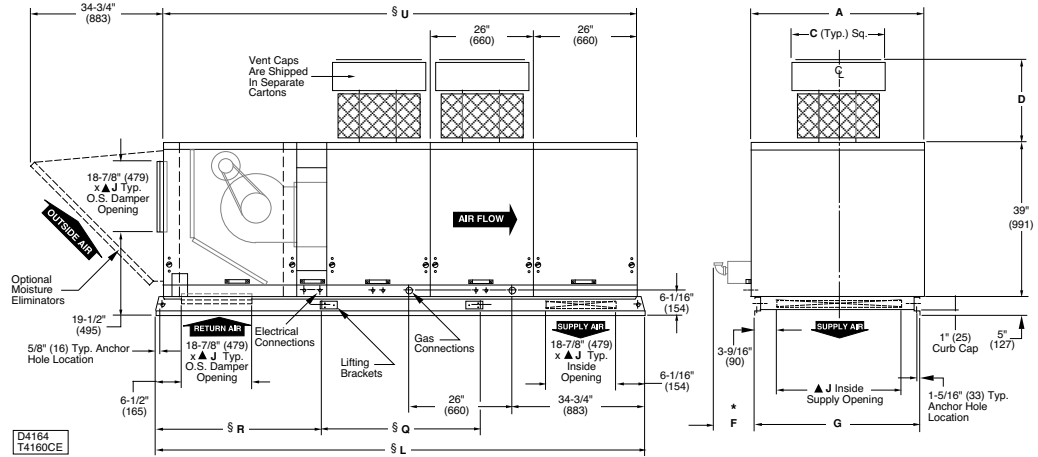

Rooftop Arrangement [RA] "C"

Capacities [CA] 10 - 80 Unit Sizes (Capacity 50 - 80 shown)

Capacity (CA)	A	C	D AGA	D CGA	*F	G	▲J	L	Q	R	§U	Gas Inlet	
												NAT	LP
10	32- 7/8 (835)	12 (305)	11 (279)	20-11/16 (525)	19- 3/8 (492)	31- 1/16 (789)	24 (610)	103- 3/8 (2626)	NA	NA	98- 1/4 (2496)	1/2	1/2
15	32- 7/8 (835)	21- 1/2 (546)	16 (406)	25- 3/16 (640)	23- 1/2 (597)	31- 1/16 (789)	24 (610)	103- 3/8 (2626)	NA	NA	98- 1/4 (2496)	1/2	1/2
20	43- 7/8 (1114)	23- 1/2 (597)	16 (406)	25- 3/16 (640)	26- 1/4 (667)	42- 1/16 (1068)	35 (889)	103- 3/8 (2626)	NA	NA	98- 1/4 (2496)	1/2	1/2
25	43- 7/8 (1114)	23- 1/2 (597)	16 (406)	25- 3/16 (640)	34- 1/2 (876)	42- 1/16 (1068)	35 (889)	103- 3/8 (2626)	NA	NA	98- 1/4 (2496)	3/4	1/2 OR 3/4
30	54- 7/8 (1394)	26 (660)	17- 1/2 (445)	26-11/16 (678)	37- 1/4 (946)	53- 1/16 (1348)	46 (1168)	103- 3/8 (2626)	NA	NA	98- 1/4 (2496)	3/4	1/2 OR 3/4
35	54- 7/8 (1394)	26 (660)	17- 1/2 (445)	26-11/16 (678)	45- 1/2 (1156)	53- 1/16 (1348)	46 (1168)	103- 3/8 (2626)	NA	NA	98- 1/4 (2496)	3/4	1/2 OR 3/4
40	60- 3/8 (1534)	26 (660)	17- 1/2 (445)	26-11/16 (678)	51 (1295)	58- 9/16 (1487)	51- 1/2 (1308)	103- 3/8 (2626)	NA	NA	98- 1/4 (2496)	3/4	1/2 OR 3/4
50	43- 7/8 (1114)	23- 1/2 (597)	16 (406)	25- 3/16 (640)	34- 1/2 (876)	42- 1/16 (1068)	35 (889)	129- 5/16 (3285)	58- 3/4 (1492)	38- 5/8 (981)	124- 1/4 (3156)	3/4	1/2 OR 3/4
60	54- 7/8 (1394)	26 (660)	17- 1/2 (445)	26-11/16 (678)	37- 1/4 (946)	53- 1/16 (1348)	46 (1168)	129- 5/16 (3285)	58- 3/4 (1492)	38- 5/8 (981)	124- 1/4 (3156)	3/4	1/2 OR 3/4
70	54- 7/8 (1394)	26 (660)	17- 1/2 (445)	26-11/16 (678)	45- 1/2 (1156)	53- 1/16 (1348)	46 (1168)	129- 5/16 (3285)	58- 3/4 (1492)	38- 5/8 (981)	124- 1/4 (3156)	3/4	1/2 OR 3/4
80	60- 3/8 (1534)	26 (660)	17- 1/2 (445)	26-11/16 (678)	51 (1295)	58- 9/16 (1487)	51- 1/2 (1308)	129- 5/16 (3285)	58- 3/4 (1492)	38- 5/8 (981)	124- 1/4 (3156)	3/4	1/2 OR 3/4

NOTES: Dimensions are in inches. Dimensions in parenthesis are in millimeters.

* "F" Dimension is the recommended clearance to service the burner drawer.

▲ "J" Dimension is an outside dimension for the return air damper(s); and "J" is also the inside dimension for the supply opening (without a damper).

§ All dimensions are tabulated for Rooftop Arrangements C & E per capacities 10 through 80 accordingly (Capacities 50/80 are shown pictorially).

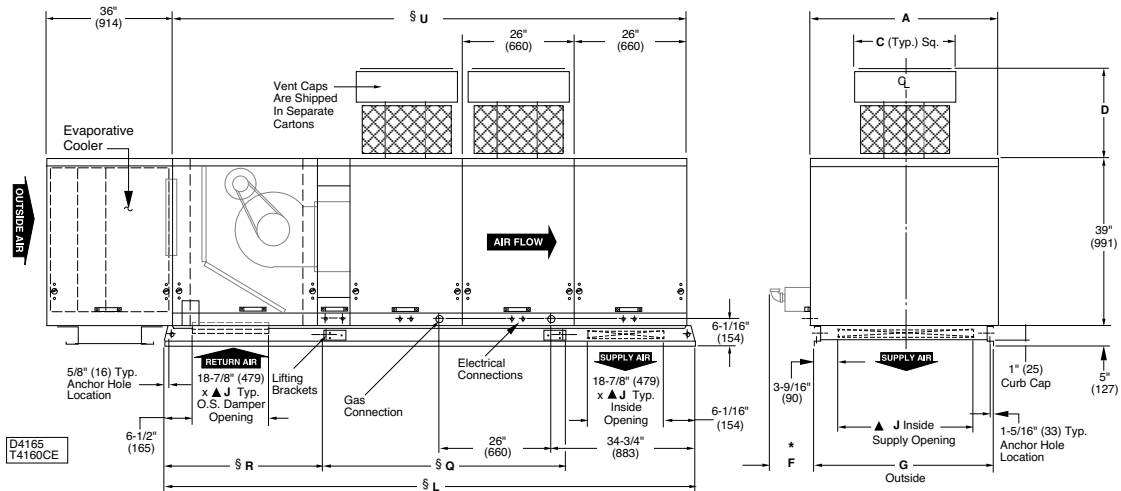

Rooftop Arrangement [RA] "E"

Capacities [CA] 10 - 80 Unit Sizes (Capacity 50 - 80 shown)

Dimensional Data – Arrangements

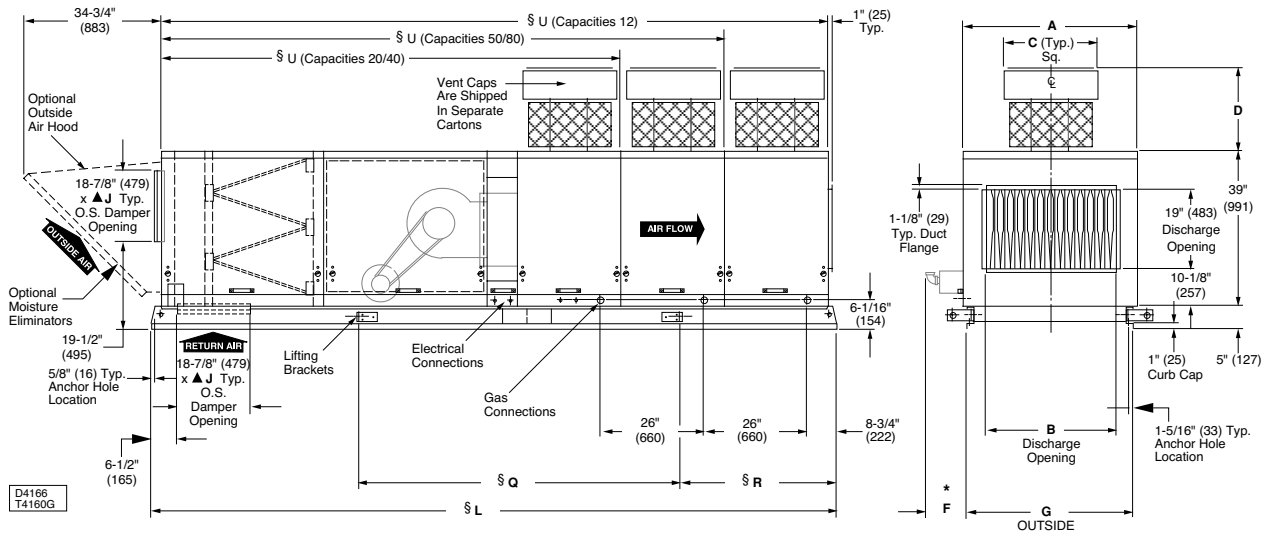

Rooftop Arrangement [RA] "G"
 Capacities [CA] 20 - 12 Unit Sizes
 Capacity 12 shown

Capacity (CA)	A	B	C	D AGA	D CGA	*F	G	▲J	L	Q	R	§U	Gas Inlet	
													NAT	LP
20	43- 7/8 (1114)	23-13/16 (605)	23- 1/2 (597)	16 (406)	25- 3/16 (640)	26- 1/4 (667)	42- 1/16 (1068)	35 (889)	113- 1/2 (2883)	60- 5/16 (1532)	26- 5/8 (676)	108- 1/2 (2756)	1/2	1/2
25	43- 7/8 (1114)	29- 5/16 (745)	23- 1/2 (597)	16 (406)	25- 3/16 (640)	34- 1/2 (876)	42- 1/16 (1068)	35 (889)	113- 1/2 (2883)	60- 5/16 (1532)	26- 5/8 (676)	108- 1/2 (2756)	3/4	1/2 OR 3/4
30	54- 7/8 (1394)	34-13/16 (884)	26 (660)	17- 1/2 (445)	26-11/16 (678)	37- 1/4 (946)	53- 1/16 (1348)	46 (1168)	113- 1/2 (2883)	60- 5/16 (1532)	26- 5/8 (676)	108- 1/2 (2756)	3/4	1/2 OR 3/4
35	54- 7/8 (1394)	40- 5/16 (1024)	26 (660)	17- 1/2 (445)	26-11/16 (678)	45- 1/2 (1156)	53- 1/16 (1348)	46 (1168)	113- 1/2 (2883)	60- 5/16 (1532)	26- 5/8 (676)	108- 1/2 (2756)	3/4	1/2 OR 3/4
40	60- 3/8 (1534)	45-13/16 (1164)	26 (660)	17- 1/2 (445)	26-11/16 (678)	51 (1295)	58- 9/16 (1487)	51- 1/2 (1308)	113- 1/2 (2883)	60- 5/16 (1532)	26- 5/8 (676)	108- 1/2 (2756)	3/4	1/2 OR 3/4
50	43- 7/8 (1114)	29- 5/16 (745)	23- 1/2 (597)	16 (406)	25- 3/16 (640)	34- 1/2 (876)	42- 1/16 (1068)	35 (889)	139- 1/2 (3543)	60-13/16 (1545)	35- 1/8 (892)	134- 1/2 (3416)	3/4	1/2 OR 3/4
60	54- 7/8 (1394)	34-13/16 (884)	26 (660)	17- 1/2 (445)	26-11/16 (678)	37- 1/4 (946)	53- 1/16 (1348)	46 (1168)	139- 1/2 (3543)	60-13/16 (1545)	35- 1/8 (892)	134- 1/2 (3416)	3/4	1/2 OR 3/4
70	54- 7/8 (1394)	40- 5/16 (1024)	26 (660)	17- 1/2 (445)	26-11/16 (678)	45- 1/2 (1156)	53- 1/16 (1348)	46 (1168)	139- 1/2 (3543)	60-13/16 (1545)	35- 1/8 (892)	134- 1/2 (3416)	3/4	1/2 OR 3/4
80	60- 3/8 (1534)	45-13/16 (1164)	26 (660)	17- 1/2 (445)	26-11/16 (678)	51 (1295)	58- 9/16 (1487)	51- 1/2 (1308)	139- 1/2 (3543)	60-13/16 (1545)	35- 1/8 (892)	134- 1/2 (3416)	3/4	1/2 OR 3/4
12	60- 3/8 (1534)	45-13/16 (1164)	26 (660)	17- 1/2 (445)	26-11/16 (678)	51 (1295)	58- 9/16 (1487)	51- 1/2 (1308)	165- 1/2 (4204)	86- 1/8 (2188)	35- 1/8 (892)	160- 1/2 (4077)	3/4	1/2 OR 3/4

NOTES: Dimensions are in inches. Dimensions in parenthesis are in millimeters.
 * "F" Dimension is the recommended clearance to service the burner drawer.
 ▲ "J" Dimension is an outside dimension for the return air damper(s).
 § All dimensions are tabulated for Rooftop Arrangement G, per capacities 20 through 12 accordingly (Capacities 12 is shown pictorially).

Dimensional Data – Arrangements

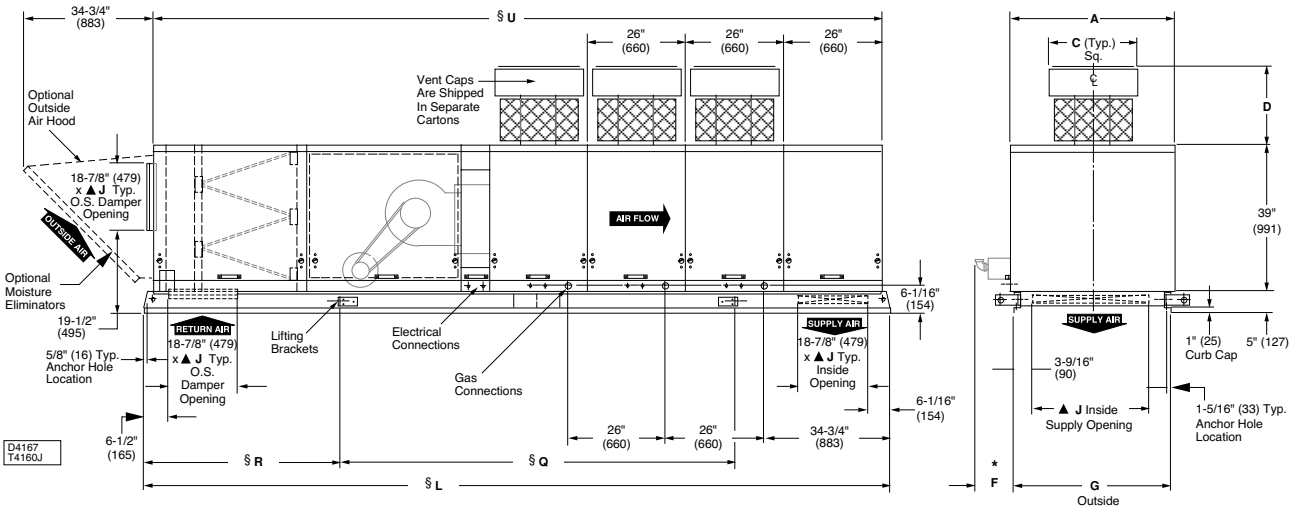

Rooftop Arrangement [RA] “J”
 Capacities [CA] 20 - 12 Unit Sizes
 Capacity 12 shown

Capacity (CA)	A	C	D AGA	D CGA	*F	G	▲J	L	Q	R	§U	Gas Inlet	
												NAT	LP
20	43- 7/8 (1114)	23- 1/2 (597)	16 (406)	25- 3/16 (640)	26- 1/4 (667)	42- 1/16 (1068)	35 (889)	139- 1/2 (3543)	60-13/16 (1545)	43- 9/16 (1106)	134- 1/2 (3416)	1/2	1/2
25	43- 7/8 (1114)	23- 1/2 (597)	16 (406)	25- 3/16 (640)	34- 1/2 (876)	42- 1/16 (1068)	35 (889)	139- 1/2 (3543)	60-13/16 (1545)	43- 9/16 (1106)	134- 1/2 (3416)	3/4	1/2 OR 3/4
30	54- 7/8 (1394)	26 (660)	17- 1/2 (445)	26-11/16 (678)	37- 1/4 (946)	53- 1/16 (1348)	46 (1168)	139- 1/2 (3543)	60-13/16 (1545)	43- 9/16 (1106)	134- 1/2 (3416)	3/4	1/2 OR 3/4
35	54- 7/8 (1394)	26 (660)	17- 1/2 (445)	26-11/16 (678)	45- 1/2 (1156)	53- 1/16 (1348)	46 (1168)	139- 1/2 (3543)	60-13/16 (1545)	43- 9/16 (1106)	134- 1/2 (3416)	3/4	1/2 OR 3/4
40	60- 3/8 (1534)	26 (660)	17- 1/2 (445)	26-11/16 (678)	51 (1295)	58- 9/16 (1487)	51- 1/2 (1308)	139- 1/2 (3543)	60- 13/16 (1545)	43- 9/16 (1106)	134- 1/2 (3416)	3/4	1/2 OR 3/4
50	43- 7/8 (1114)	23- 1/2 (597)	16 (406)	25- 3/16 (640)	34- 1/2 (876)	42- 1/16 (1068)	35 (889)	165- 1/2 (4204)	86- 1/8 (2188)	44- 1/4 (892)	160- 1/2 (4077)	3/4	1/2 OR 3/4
60	54- 7/8 (1394)	26 (660)	17- 1/2 (445)	26-11/16 (678)	37- 1/4 (946)	53- 1/16 (1348)	46 (1168)	165- 1/2 (4204)	86- 1/8 (2188)	44- 1/4 (1124)	160- 1/2 (4077)	3/4	1/2 OR 3/4
70	54- 7/8 (1394)	26 (660)	17- 1/2 (445)	26-11/16 (678)	45- 1/2 (1156)	53- 1/16 (1348)	46 (1168)	165- 1/2 (4204)	86- 1/8 (2188)	44- 1/4 (1124)	160- 1/2 (4077)	3/4	1/2 OR 3/4
80	60- 3/8 (1534)	26 (660)	17- 1/2 (445)	26-11/16 (678)	51 (1295)	58- 9/16 (1487)	51- 1/2 (1308)	165- 1/2 (4204)	86- 1/8 (2188)	44- 1/4 (1124)	160- 1/2 (4077)	3/4	1/2 OR 3/4
12	60- 3/8 (1534)	26 (660)	17- 1/2 (445)	26-11/16 (678)	51 (1295)	58- 9/16 (1487)	51- 1/2 (1308)	191- 1/2 (4864)	99- 7/16 (2526)	44- 1/4 (1124)	186- 1/2 (4737)	3/4	1/2 OR 3/4

NOTES: Dimensions are in inches Dimensions in parenthesis are in millimeters.

* *F” Dimension is the recommended clearance to service the burner drawer.

▲ “J” Dimension is an outside dimension for the return air damper(s); and “J” is also the inside dimension for the supply opening (without a damper).

§ All dimensions are tabulated for Rooftop Arrangement J, per capacities 20 through 12 accordingly (Capacity 12 is shown pictorially).

Dimensional Data – Arrangements

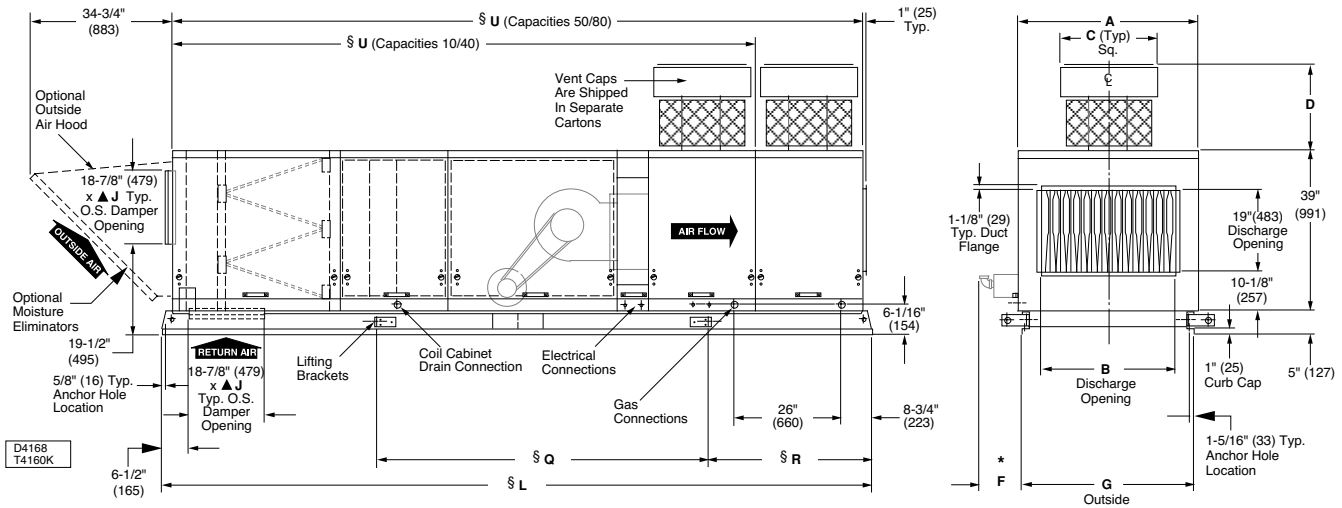

Rooftop Arrangement [RA] "K"
 Capacities [CA] 10 - 80 Unit Sizes
 Capacity 50 - 80 shown

Capacity (CA)	A	B	C	D AGA	D CGA	*F	G	▲J	L	Q	R	§U	Gas Inlet	
													NAT	LP
10	32- 7/8 (835)	15- 9/16 (395)	12 (305)	11 (279)	20-11/16 (525)	19- 3/8 (492)	31- 1/16 (789)	24 (610)	139- 1/2 (3543)	52- 1/2 (1334)	43- 1/2 (1105)	134- 1/2 (3416)	1/2	1/2
15	32- 7/8 (835)	18- 5/16 (465)	21- 1/2 (546)	16 (406)	25- 3/16 (640)	23- 1/2 (597)	31- 1/16 (789)	24 (610)	139- 1/2 (3543)	52- 1/2 (1334)	43- 1/2 (1105)	134- 1/2 (3416)	1/2	1/2
20	43- 7/8 (1114)	23-13/16 (605)	23- 1/2 (597)	16 (406)	25- 3/16 (640)	26- 1/4 (667)	42- 1/16 (1068)	35 (889)	139- 1/2 (3543)	52- 1/2 (1334)	43- 1/2 (1105)	134- 1/2 (3416)	1/2	1/2
25	43- 7/8 (1114)	29- 5/16 (745)	23- 1/2 (597)	16 (406)	25- 3/16 (640)	34- 1/2 (876)	42- 1/16 (1068)	35 (889)	139- 1/2 (3543)	52- 1/2 (1334)	43- 1/2 (1105)	134- 1/2 (3416)	3/4	1/2 OR 3/4
30	54- 7/8 (1394)	34-13/16 (884)	26 (660)	17- 1/2 (445)	26-11/16 (678)	37- 1/4 (946)	53- 1/16 (1348)	46 (1168)	139- 1/2 (3543)	52- 1/2 (1334)	43- 1/2 (1105)	134- 1/2 (3416)	3/4	1/2 OR 3/4
35	54- 7/8 (1394)	40- 5/16 (1024)	26 (660)	17- 1/2 (445)	26-11/16 (678)	45- 1/2 (1156)	53- 1/16 (1348)	46 (1168)	139- 1/2 (3543)	52- 1/2 (1334)	43- 1/2 (1105)	134- 1/2 (3416)	3/4	1/2 OR 3/4
40	60- 3/8 (1534)	45-13/16 (1164)	26 (660)	17- 1/2 (445)	26-11/16 (678)	51 (1295)	58- 9/16 (1487)	51- 1/2 (1308)	139- 1/2 (3543)	52- 1/2 (1334)	43- 1/2 (1105)	134- 1/2 (3416)	3/4	1/2 OR 3/4
50	43- 7/8 (1114)	29- 5/16 (745)	23- 1/2 (597)	16 (406)	25- 3/16 (640)	34- 1/2 (876)	42- 1/16 (1068)	35 (889)	165- 1/2 (4204)	86- 1/8 (2188)	35- 1/8 (892)	160- 1/2 (4077)	3/4	1/2 OR 3/4
60	54- 7/8 (1394)	34-13/16 (884)	26 (660)	17- 1/2 (445)	26-11/16 (678)	37- 1/4 (946)	53- 1/16 (1348)	46 (1168)	165- 1/2 (4204)	86- 1/8 (2188)	35- 1/8 (892)	160- 1/2 (4077)	3/4	1/2 OR 3/4
70	54- 7/8 (1394)	40- 5/16 (1024)	26 (660)	17- 1/2 (445)	26-11/16 (678)	45- 1/2 (1156)	53- 1/16 (1348)	46 (1168)	165- 1/2 (4204)	86- 1/8 (2188)	35- 1/8 (892)	160- 1/2 (4077)	3/4	1/2 OR 3/4
80	60- 3/8 (1534)	45-13/16 (1164)	26 (660)	17- 1/2 (445)	26-11/16 (678)	51 (1295)	58- 9/16 (1487)	51- 1/2 (1308)	165- 1/2 (4204)	86- 1/8 (2188)	35- 1/8 (892)	160- 1/2 (4077)	3/4	1/2 OR 3/4

NOTES: Dimensions are in inches. Dimensions in parenthesis are in millimeters.
 * "F" Dimension is the recommended clearance to service the burner drawer.
 ▲ "J" Dimension is an outside dimension for the return air damper(s).
 § All dimensions are tabulated for Rooftop Arrangement K per capacities 10 through 80 accordingly (Capacities 50/80 are shown pictorially).

Dimensional Data – Arrangements

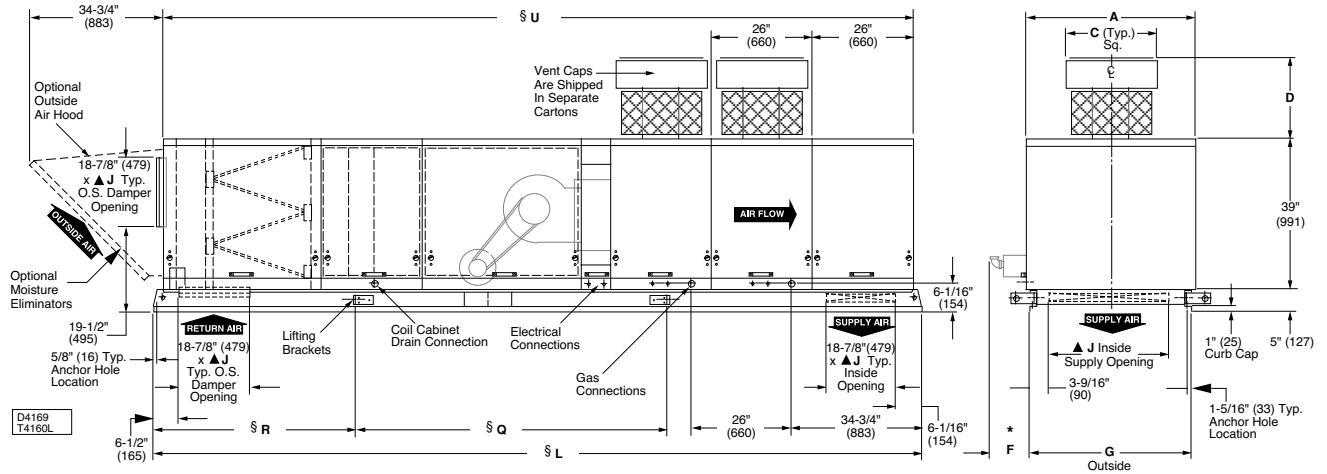

Rooftop Arrangement [RA] "L"
 Capacities [CA] 10 - 80 Unit Sizes
 Capacity 50 - 80 shown

Capacity (CA)	Dimensions (inches)													Gas Inlet	
	A	B	C	D AGA	D CGA	*F	G	\blacktriangle J	L	Q	R	§U	NAT	LP	
10	32- 7/8 (835)	15- 9/16 (395)	12 (305)	11 (279)	20-11/16 (525)	19- 3/8 (492)	31- 1/16 (789)	24 (610)	165- 1/2 (4204)	86- 1/8 (2188)	44- 1/4 (1124)	160- 1/2 (4077)	1/2	1/2	
15	32- 7/8 (835)	18- 5/16 (465)	21- 1/2 (546)	16 (406)	25- 3/16 (640)	23- 1/2 (597)	31- 1/16 (789)	24 (610)	165- 1/2 (4204)	86- 1/8 (2188)	44- 1/4 (1124)	160- 1/2 (4077)	1/2	1/2	
20	43- 7/8 (1114)	23-13/16 (605)	23- 1/2 (597)	16 (406)	25- 3/16 (640)	26- 1/4 (667)	42- 1/16 (1068)	35 (889)	165- 1/2 (4204)	86- 1/8 (2188)	44- 1/4 (1124)	160- 1/2 (4077)	1/2	1/2	
25	43- 7/8 (1114)	29- 5/16 (745)	23- 1/2 (597)	16 (406)	25- 3/16 (640)	34- 1/2 (876)	42- 1/16 (1068)	35 (889)	165- 1/2 (4204)	86- 1/8 (2188)	44- 1/4 (1124)	160- 1/2 (4077)	3/4	1/2 OR 3/4	
30	54- 7/8 (1394)	34-13/16 (884)	26 (660)	17- 1/2 (445)	26-11/16 (678)	37- 1/4 (946)	53- 1/16 (1348)	46 (1168)	165- 1/2 (4204)	86- 1/8 (2188)	44- 1/4 (1124)	160- 1/2 (4077)	3/4	1/2 OR 3/4	
35	54- 7/8 (1394)	40- 5/16 (1024)	26 (660)	17- 1/2 (445)	26-11/16 (678)	45- 1/2 (1156)	53- 1/16 (1348)	46 (1168)	165- 1/2 (4204)	86- 1/8 (2188)	44- 1/4 (1124)	160- 1/2 (4077)	3/4	1/2 OR 3/4	
40	60- 3/8 (1534)	45-13/16 (1164)	26 (660)	17- 1/2 (445)	26-11/16 (678)	51 (1295)	58- 9/16 (1487)	51- 1/2 (1308)	165- 1/2 (4204)	86- 1/8 (2188)	44- 1/4 (1124)	160- 1/2 (4077)	3/4	1/2 OR 3/4	
50	43- 7/8 (1114)	29- 5/16 (745)	23- 1/2 (597)	16 (406)	25- 3/16 (640)	34- 1/2 (876)	42- 1/16 (1068)	35 (889)	191- 1/2 (4864)	99- 7/16 (2526)	44- 1/4 (1124)	186- 1/2 (4737)	3/4	1/2 OR 3/4	
60	54- 7/8 (1394)	34-13/16 (884)	26 (660)	17- 1/2 (445)	26-11/16 (678)	37- 1/4 (946)	53- 1/16 (1348)	46 (1168)	191- 1/2 (4864)	99- 7/16 (2526)	44- 1/4 (1124)	186- 1/2 (4737)	3/4	1/2 OR 3/4	
70	54- 7/8 (1394)	40- 5/16 (1024)	26 (660)	17- 1/2 (445)	26-11/16 (678)	45- 1/2 (1156)	53- 1/16 (1348)	46 (1168)	191- 1/2 (4864)	99- 7/16 (2526)	44- 1/4 (1124)	186- 1/2 (4737)	3/4	1/2 OR 3/4	
80	60- 3/8 (1534)	45-13/16 (1164)	26 (660)	17- 1/2 (445)	26-11/16 (678)	51 (1295)	58- 9/16 (1487)	51- 1/2 (1308)	191- 1/2 (4864)	99- 7/16 (2526)	44- 1/4 (1124)	186- 1/2 (4737)	3/4	1/2 OR 3/4	

NOTES: Dimensions are in inches. Dimensions in parenthesis are in millimeters.
 * "F" Dimension is the recommended clearance to service the burner drawer.
 \blacktriangle "J" Dimension is an outside dimension for the return air damper(s), and "J" is also the inside dimension for the supply opening (without a damper).
 § All dimensions are tabulated for Rooftop Arrangement L per capacities 10 through 80 accordingly (Capacities 50/80 are shown pictorially).

Cooling Coil Options

Rooftop Arrangement [RA] (K,L,U,W) Coil Options [CO] Model Digit 8

Sterling Engineered Products is pleased to include coil cabinets and factory installed coils to our Packaged Rooftop Unit. As standard equipment, we now offer 4 or 6 row, single or dual circuit intertwine, DX (20 tons max.) or chilled water coils. Hot water and steam heating coils are also available. Sterling coil cabinets feature draw through design to ensure even air flow across the coil face and a one piece 409 stainless steel positive drain drip pan conforming to ASHRAE standard No. 62-1989. The positive drain pan is designed for side outlet drainage piping.

Please refer to tables 8A, 8B, 9A and 9B for Cooling Coil Performance Data.

Whenever a Cooling Coil is used upstream of a furnace section(s), Sterling highly recommends a 409 stainless steel heat exchanger(s) to be used.

Rooftop Arrangements (K,L,U,W) should not exceed 6,300 CFM (3.0 m³/s) or face velocities of 600 FPM (3.0 m/s).

Coil Options [CO] Digit 8

- A** - DX Coil, 4 Row, Single Circuit
- B** - DX Coil, 4 Row, Dual Circuit
- C** - DX Coil, 6 Row, Single Circuit
- D** - DX Coil, 6 Row, Dual Circuit
- E** - Chilled Water Coil, 4 Row
- G** - Chilled Water Coil, 6 Row
- O** - None
- Z** - Other (Special)

UNIT SIZE	" L" INSIDE MAX. CABINET OPENING
10/15	31-1/4" (794)
20/25/50	42-1/4" (1073)
30/35/60/70	53-1/4" (1353)
40/80	58-3/4" (1492)

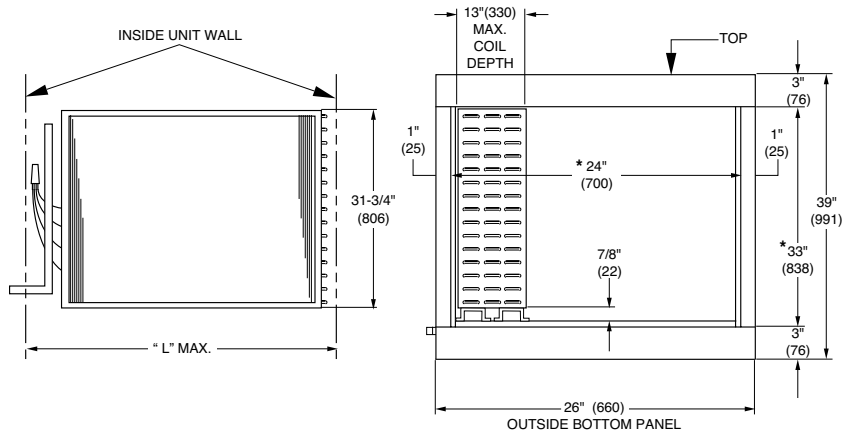

MAXIMUM COIL DIMENSIONS

SIDE OPENING OF COOLING MODULE



Cooling Coil Options [CO] – Table 8A

Rooftop Arrangements (K,L,U,W)

DX Cooling Coil Performance Data (Ref. R-22)

Capacity based on 80°F EDB, 67°F EWB, 45°F Sat. Suction, 100°F Liquid.

Capacity	Air Flow	Face Velocity	Fin Spacing	Coil Capacity	4 Row L.A.T.	A.P.D.	WT.	Fin Spacing	Coil Capacity	6 Row L.A.T.	A.P.D.	WT.	
	SCFM	FPM	FPF	MBH	DB / WB	IN. W.C.	LBS.	FPF	MBH	DB / WB	IN. W.C.	LBS.	
10,15	1200	240	99	40.0	57 / 56	0.16	87						
			136	45.0	55 / 54	0.18	92						
			167	48.0	54 / 54	0.22	97						
	1500	300	117	50.0	57 / 56	0.24	90						
			136	53.0	56 / 55	0.26	92						
			168	57.0	55 / 54	0.32	97						
	2000	400	103	57.4	59 / 58	0.36	88						
			139	65.0	57 / 56	0.42	93						
			163	69.0	56 / 55	0.49	96						
	2500	500	102	65.0	60 / 58	0.49	88	113	80.0	57 / 56	0.76		
			140	75.0	58 / 57	0.59	93	133	85.0	56 / 56	0.84	125	
			166	80.0	57 / 56	0.70	97	168	92.0	55 / 55	1.06	132	
	3000	601	100	71.3	61 / 59	0.63	87	97	84.3	59 / 58	0.92	117	
			136	82.0	59 / 58	0.75	92	109	89.0	58 / 57	0.98	120	
147			85.0	58 / 58	0.81	94	132	96.1	57 / 56	1.10	125		
20,25,50	1600	216	84	56.6	56 / 55	0.12	111	107	70.0	52 / 52	0.21	160	
			103	61.0	55 / 54	0.14	115	130	73.4	51 / 51	0.23	167	
			127	65.0	54 / 53	0.15	120	153	76.0	51 / 51	0.25	174	
	2000	271	127	69.0	56 / 55	0.21	120	99	82.0	53 / 53	0.29	157	
			154	74.0	55 / 55	0.24	126	123	87.0	52 / 52	0.32	165	
			168	82.0	53 / 53	0.27	129	163	93.0	51 / 51	0.39	177	
	3000	406	115	88.2	58 / 57	0.38	118	103	112.0	55 / 54	0.56	158	
			147	98.0	57 / 56	0.44	124	136	122.0	53 / 53	0.65	169	
			165	104.0	56 / 55	0.52	128	167	129.0	52 / 52	0.78	178	
	4000	542	108	102.0	60 / 59	0.56	116	102	135.0	56 / 56	0.85	158	
			140	116.0	58 / 57	0.66	123	136	149.0	55 / 55	1.00	169	
			163	124.0	57 / 57	0.77	128	162	157.0	54 / 54	1.17	177	
	4400	596	104	106.0	61 / 59	0.63	115	102	143.0	57 / 56	0.97	158	
			135	120.0	59 / 58	0.73	121	137	159.0	55 / 55	1.16	169	
148			126.0	58 / 58	0.80	124	149	163.0	55 / 55	1.23	173		
30,35,60,70	2400	245	101	85.0	56 / 55	0.17	147	84	100.6	53 / 53	0.23	197	
			129	93.0	54 / 54	0.19	155	109	108.0	52 / 52	0.27	207	
			162	100.0	53 / 53	0.22	164	146	115.0	51 / 50	0.30	223	
	3000	307	104	101.0	57 / 56	0.25	148	90	121.0	54 / 53	0.34	200	
			140	113.0	55 / 54	0.28	158	124	132.0	52 / 52	0.40	213	
			168	120.0	54 / 54	0.33	165	157	139.0	51 / 51	0.47	227	
	4000	409	102	121.0	58 / 57	0.38	147	100	152.0	55 / 54	0.57	204	
			135	136.0	56 / 56	0.43	156	131	164.0	53 / 53	0.65	216	
			167	147.0	55 / 55	0.53	165	166	173.0	52 / 52	0.79	231	
	5000	512	93	132.0	60 / 58	0.50	145	98	173.0	56 / 55	0.78	203	
			134	156.0	57 / 57	0.61	156	151	189.0	54 / 54	0.99	224	
			167	170.0	56 / 56	0.74	165	166	199.0	54 / 54	1.12	231	
	5700	583	99	146.0	60 / 59	0.62	146	95	184.0	57 / 56	0.92	202	
			128	165.0	58 / 57	0.71	154	121	198.0	56 / 55	1.04	212	
153			177.0	57 / 57	0.82	161	146	208.0	55 / 55	1.19	223		
40,80	3300	304	104	114.0	56 / 55	0.24	160	84	131.6	54 / 54	0.33	214	
			140	127.0	54 / 54	0.28	171	105	140.0	53 / 53	0.37	224	
			165	134.0	53 / 53	0.32	179	158	153.0	51 / 51	0.46	248	
	4000	368	101	128.0	58 / 56	0.32	159	99	157.0	54 / 54	0.48	221	
			134	143.0	56 / 55	0.37	169	128	168.0	53 / 53	0.55	234	
			166	154.0	54 / 54	0.45	179	166	177.0	52 / 52	0.67	252	
	5000	460	99	145.0	59 / 57	0.45	159	97	179.0	56 / 55	0.67	220	
			132	164.0	57 / 56	0.52	169	142	196.0	54 / 54	0.80	240	
			167	178.0	55 / 55	0.64	179	167	206.0	53 / 53	0.95	252	
	6000	552	98	160.0	60 / 58	0.58	158	102	200.0	57 / 56	0.88	223	
			134	182.0	58 / 57	0.68	169	143	224.0	55 / 54	1.06	241	
			160	194.0	57 / 56	0.79	177	161	233.0	54 / 54	1.19	249	
	6300	580	97	163.0	60 / 58	0.61	158	104	205.0	57 / 56	0.93	223	
			134	187.0	58 / 57	0.73	169	138	229.0	55 / 55	1.11	239	
153			196.0	57 / 57	0.81	175	154	238.0	54 / 54	1.22	246		

Conversions: 2119 SCFM = 1m³/s, 196.8FPM = 1m/s, 3.412 MBH = 1kW, (°F-32) 5/9 = °C, 1 IN.W.C. = 248.8 Pa, 0.4536 kg = 1 lb.

NOTES: 1) Data certified in accordance with ARI Standard 410.

2) Capacity based on 80°F EDB, 67°F EWB, 45°F Sat. Suction, 100°F Liquid.

3) Weight listed is the total weight of the dry coil.

4) Consult Customer Service Department for special coil requirements.

Cooling Coil Options [CO] – Table 8B

Rooftop Arrangements (K,L,U,W)

DX Cooling Coil Performance Data (Ref. R-22)

Capacity based on 95°F EDB, 74°F EWB, 45°F Sat. Suction, 100°F Liquid.

OPTIONS

Capacity	Air Flow	Face Velocity	Fin Spacing	Coil Capacity	4 Row L.A.T.	A.P.D.	WT.	Fin Spacing	Coil Capacity	6 Row L.A.T.	A.P.D.	WT.	
	SCFM	FPM	FPF	MBH	DB / WB	IN. W.C.	LBS.	FPF	MBH	DB / WB	IN. W.C.	LBS.	
10,15	1200	240	84	60.9	61/ 59	0.15	85	84	70.0	57/ 57	0.21	115	
			118	69.0	58/ 57	0.18	90	121	78.0	54/ 54	0.26	122	
			155	75.0	55/ 55	0.20	95	159	83.0	55/ 53	0.31	130	
	1500	300	97	75.0	61/ 59	0.23	87	89	85.0	58/ 57	0.32	116	
			123	82.0	59/ 59	0.26	91	128	95.0	55/ 55	0.39	124	
			168	90.1	56/ 56	0.32	97	164	101.0	53/ 53	0.46	131	
	2000	400	98	90.0	63/ 61	0.36	87	102	110.0	58/ 58	0.54	118	
			131	100.0	60/ 59	0.41	92	129	119.0	56/ 56	0.61	124	
			163	107.0	59/ 58	0.49	96	162	127.0	55/ 55	0.73	131	
	2500	500	98	101.0	65/ 62	0.50	87	101	128.0	60/ 59	0.75	118	
			129	112.0	62/ 61	0.57	91	129	140.0	58/ 57	0.85	124	
			164	121.0	61/ 60	0.70	96	161	150.0	56/ 56	1.03	131	
	3000	601	101	111.0	66/ 63	0.65	88	99	143.0	61/ 60	0.96	118	
			134	121.0	64/ 62	0.74	92	128	158.0	59/ 58	1.11	124	
			149	128.0	63/ 62	0.82	94	147	166.0	58/ 58	1.23	128	
	20,25,50	1600	216	97	91.0	58/ 57	0.14	114	84	103.2	55/ 54	0.18	153
				123	97.0	56/ 56	0.15	119	117	112.0	52/ 52	0.22	163
				165	104.0	54/ 54	0.19	128	162	119.0	51/ 51	0.27	177
2000		271	102	106.0	60/ 58	0.20	115	97	128.0	55/ 54	0.29	157	
			136	117.0	57/ 56	0.23	122	127	137.0	53/ 53	0.33	166	
			159	123.0	56/ 55	0.25	127	164	144.0	52/ 52	0.40	177	
3000		406	98	136.0	63/ 61	0.37	114	94	170.0	58/ 57	0.54	156	
			133	155.0	60/ 59	0.43	121	144	181.0	56/ 56	0.67	171	
			167	169.0	58/ 57	0.52	128	159	195.0	54/ 54	0.74	176	
4000		542	95	159.0	66/ 63	0.55	113	99	205.0	60/ 59	0.84	157	
			132	184.0	62/ 61	0.65	121	138	221.0	58/ 58	1.00	169	
			164	200.0	60/ 59	0.79	128	159	232.0	57/ 57	1.13	176	
4400		596	93	165.0	67/ 63	0.62	113	98	215.0	61/ 60	0.96	157	
			134	195.0	63/ 61	0.75	122	134	234.0	59/ 58	1.12	168	
			150	204.0	62/ 61	0.83	125	150	244.0	58/ 57	1.23	173	
30,35,60,70		2400	245	99	135.0	59/ 57	0.17	146	96	159.0	54/ 54	0.25	202
				134	149.0	56/ 55	0.20	156	130	169.0	52/ 52	0.29	216
				161	157.0	54/ 54	0.22	163	163	175.0	51/ 51	0.34	229
	3000	307	96	156.0	60/ 59	0.24	146	96	186.0	56/ 55	0.36	202	
			131	174.0	57/ 57	0.28	155	134	200.0	54/ 54	0.42	218	
			168	187.0	55/ 55	0.34	165	167	210.0	52/ 52	0.50	231	
	4000	409	97	186.0	63/ 60	0.38	146	99	227.0	58/ 57	0.56	203	
			132	209.0	60/ 59	0.44	155	135	251.0	55/ 55	0.65	218	
			168	225.0	58/ 57	0.54	165	168	266.0	54/ 54	0.80	231	
	5000	512	98	210.0	65/ 62	0.52	146	99	265.0	59/ 58	0.77	203	
			136	238.0	61/ 60	0.62	157	134	295.0	57/ 56	0.91	217	
			165	250.0	60/ 59	0.72	164	166	315.0	55/ 55	1.12	315	
	5700	583	98	224.0	66/ 63	0.62	146	99	288.0	60/ 59	0.93	203	
			138	255.0	62/ 61	0.75	157	132	322.0	58/ 57	1.10	217	
			153	264.0	62/ 61	0.81	161	154	339.0	56/ 56	1.25	226	
	40,80	3300	304	96	173.0	60/ 59	0.24	158	100	206.0	56/ 55	0.36	221
				125	189.0	58/ 57	0.27	167	138	225.0	53/ 53	0.42	239
				151	200.0	56/ 56	0.30	175	168	235.0	52/ 52	0.50	252
4000		368	97	195.0	62/ 62	0.32	158	99	238.0	57/ 56	0.48	221	
			129	215.0	59/ 58	0.37	168	133	260.0	54/ 54	0.55	236	
			166	227.0	57/ 57	0.44	179	167	275.0	53/ 53	0.67	252	
5000		460	98	220.0	64/ 61	0.45	158	100	279.0	58/ 57	0.67	221	
			136	245.0	61/ 60	0.52	170	133	307.0	56/ 55	0.78	236	
			165	266.0	59/ 58	0.62	179	168	328.0	54/ 54	0.97	252	
6000		552	100	242.0	65/ 62	0.58	159	97	312.0	60/ 59	0.86	220	
			139	272.0	62/ 61	0.70	171	132	348.0	57/ 57	1.02	236	
			156	293.0	61/ 60	0.76	176	159	368.0	56/ 55	1.19	248	
6300		580	101	245.0	66/ 63	0.61	159	97	322.0	60/ 59	0.92	220	
			132	280.0	63/ 61	0.71	169	132	359.0	57/ 57	1.09	236	
			154	301.0	61/ 60	0.81	175	153	376.0	56/ 56	1.23	246	

Conversions: 2119 SCFM = 1m³/s, 196.8FPM = 1m/s, 3.412 MBH = 1kW, (°F-32) 5/9 = °C, 1 IN.W.C. = 248.8 Pa, 0.4536 kg = 1 lb.

- NOTES: 1) Data certified in accordance with ARI Standard 410.
 2) Capacity based on 95°F EDB, 74°F EWB, 45°F Sat. Suction, 100°F Liquid.
 3) Weight listed is the total weight of the dry coil.
 4) Consult Customer Service Department for special coil requirements.



Cooling Coil Options [CO] – Table 9A

Rooftop Arrangements (K,L,U,W)

Chilled Water Cooling Coil Performance Data

Capacity based on 80°F EDB, 67°F EWB, 45°F EWT, 70 GPM.

Capacity	Air Flow	Face Velocity	Fin Spacing	Coil Capacity	4 Row L.A.T.	A.P.D.	WT.	Fin Spacing	Coil Capacity	6 Row L.A.T.	A.P.D.	WT.	
	SCFM	FPM	FPF	MBH	DB / WB	IN. W.C.	LBS.	FPF	MBH	DB / WB	IN. W.C.	LBS.	
10,15	1000	200	84	46.7	52/ 51	0.10	64	84	54.4	49/ 48	0.15	86	
			93	48.1	51/ 50	0.10	65	97	56.0	48/ 47	0.17	89	
			97	50.6	50/ 49	0.11	67	120	58.0	47/ 46	0.19	93	
	1600	320	84	64.1	55/ 53	0.22	64	84	78.0	51/ 50	0.33	86	
			88	68.7	54/ 52	0.23	66	101	82.0	50/ 49	0.37	90	
			105	73.3	52/ 51	0.25	68	125	86.0	49/ 48	0.41	95	
	2900	581	84	87.7	59/ 57	0.54	64	84	112.8	55/ 54	0.81	86	
			86	95.3	58/ 56	0.55	65	101	120.0	54/ 53	0.89	90	
			101	102.7	57/ 55	0.60	67	128	128.0	53/ 52	0.91	95	
	20,25,50	1800	243	84	78.8	53/ 52	0.14	83	84	93.5	50/ 49	0.21	113
				90	84.0	52/ 51	0.15	86	103	98.0	49/ 48	0.24	119
				111	90.0	51/ 50	0.17	90	123	101.2	48/ 47	0.26	125
3000		406	84	107.2	57/ 55	0.32	83	84	133.3	53/ 52	0.48	113	
			88	116.0	56/ 54	0.33	86	102	141.2	52/ 51	0.53	119	
			104	124.0	54/ 53	0.36	89	123	148.6	51/ 50	0.59	125	
4300		582	84	127.5	60/ 58	0.54	83	84	163.3	55/ 54	0.82	113	
			102	138.0	58/ 56	0.60	86	103	175.0	54/ 53	0.91	119	
			124	149.0	57/ 56	0.67	91	125	186.0	53/ 52	1.00	126	
30,35,60,70		2000	204	84	91.7	52/ 51	0.10	106	84	107.1	49/ 48	0.16	147
				93	95.0	52/ 51	0.11	109	95	110.0	48/ 48	0.17	151
				96	99.0	51/ 50	0.11	113	123	115.0	47/ 47	0.20	163
	3200	327	84	124.2	56/ 54	0.23	107	84	151.3	52/ 51	0.34	147	
			88	133.0	54/ 53	0.24	111	103	160.0	50/ 50	0.39	155	
			105	142.0	53/ 52	0.26	115	124	167.0	49/49	0.42	163	
	4500	460	84	148.8	58/ 56	0.39	107	84	186.6	54/ 53	0.58	147	
			101	160.0	57/ 55	0.43	111	103	199.0	53/ 52	0.65	155	
			103	172.0	55/ 54	0.43	115	125	210.0	52/ 51	0.71	164	
	5700	583	84	165.6	60/ 58	0.55	107	84	211.2	56/ 55	0.82	147	
			102	179.0	58/ 57	0.60	112	102	226.0	55/ 54	0.89	154	
			125	194.0	57/ 56	0.67	118	126	241.0	53/ 53	1.00	164	
40,80	2200	202	84	100.8	52/ 51	0.10	115	85	118.0	49/ 48	0.15	160	
			95	105.0	52/51	0.11	119	92	120.0	48/ 48	0.16	163	
			111	110.0	51/ 50	0.12	123	100	122.0	48/ 47	0.17	167	
	3500	322	84	136.0	55/ 54	0.22	115	84	165.4	52/ 51	0.33	159	
			102	146.0	54/ 53	0.25	121	101	174.0	50/ 50	0.37	167	
			122	155.0	53/ 52	0.27	127	125	183.0	49/ 49	0.41	178	
	4900	451	84	162.5	58/ 56	0.38	115	84	203.2	54/ 53	0.56	159	
			102	175.2	56/ 55	0.42	121	102	216.0	53/ 52	0.63	168	
			124	188.1	55/ 54	0.46	127	124	228.0	52/ 51	0.69	178	
	6300	580	84	181.9	60/ 58	0.54	115	84	231.0	56/ 55	0.81	159	
			104	198.0	58/ 57	0.60	121	104	249.0	54/ 54	0.89	168	
			103	213.0	57/ 56	0.60	213	125	264.0	53/ 53	0.98	178	

Conversions: 2119 SCFM = 1m³/s, 196.8FPM = 1m/s, 3.412 MBH = 1kW, (°F-32) 5/9 = °C, 1 IN.W.C. = 248.8 Pa, 0.4536 kg = 1 lb.

NOTES: 1) Data certified in accordance with ARI Standard 410.

2) Capacity based on 80°F EDB, 67°F EWB, 45°F EWT, 70 GPM.

3) Weight listed is the total weight of the dry coil.

4) Consult Customer Service Department for special coil requirements.

Cooling Coil Options [CO] – Table 9B

Rooftop Arrangements (K,L,U,W)

Chilled Water Cooling Coil Performance Data

Capacity based on 95°F EDB, 74°F EWB, 45°F EWT, 70 GPM.

Capacity	Air Flow	Face Velocity	Fin Spacing	Coil Capacity	4 Row L.A.T.	A.P.D.	WT.	Fin Spacing	Coil Capacity	6 Row L.A.T.	A.P.D.	WT.	
	SCFM	FPM	FPF	MBH	DB / WB	IN. W.C.	LBS.	FPF	MBH	DB / WB	IN. W.C.	LBS.	
10,15	1000	200	84	66.4	55/ 54	0.10	64	84	77.4	50/ 49	0.15	86	
			94	69.0	54/ 53	0.11	65	87	78.0	50/ 49	0.15	87	
			115	73.0	52/ 51	0.12	68	106	81.0	48/ 48	0.18	91	
	1600	320	84	90.7	59/ 57	0.22	64	84	110.7	54/ 53	0.33	86	
			101	97.3	57/ 56	0.25	66	100	116.0	52/ 51	0.37	89	
			129	103.8	55/ 54	0.25	70	120	121.0	51/ 50	0.40	93	
	2900	581	84	123.4	66/ 62	0.54	64	84	159.1	59/ 58	0.81	86	
			104	135.0	63/ 60	0.61	66	102	170.0	57/ 56	0.89	90	
			125	145.0	61/ 59	0.66	69	126	182.0	56/ 55	1.00	95	
	20,25,50	1800	243	84	111.8	57/ 55	0.14	83	84	132.8	52/ 51	0.21	113
				101	119.0	55/ 54	0.16	86	101	138.6	50/ 50	0.24	118
				126	127.0	53/ 52	0.18	91	123	144.0	49/ 48	0.26	125
3000		406	84	151.3	62/ 59	0.32	83	84	188.5	56/ 55	0.48	113	
			102	163.0	60/ 58	0.36	86	102	200.0	54/ 54	0.54	119	
			124	175.0	58/ 57	0.40	91	125	211.0	53/ 52	0.59	126	
4300		582	84	179.2	66/ 62	0.54	83	84	230.2	60/ 58	0.81	113	
			103	195.0	64/ 61	0.60	86	104	248.0	58/ 57	0.90	119	
			126	211.0	61/ 60	0.66	91	127	264.0	46/ 55	1.00	126	
30,35,60,70		2000	204	84	130.2	56/ 54	0.10	107	84	152.3	51/ 50	0.16	147
				92	134.0	55/ 53	0.11	109	91	155.0	50/ 49	0.17	150
				108	141.0	53/ 52	0.12	113	103	159.0	49/ 49	0.18	155
	3200	327	84	175.5	60/ 58	0.23	107	84	214.3	54/ 53	0.34	147	
			101	188.0	58/ 56	0.26	111	100	225.0	53/ 52	0.38	154	
			124	201.0	56/ 55	0.28	118	125	237.0	51/ 51	0.42	164	
	4500	460	84	209.5	64/ 60	0.39	107	84	263.2	58/ 56	0.58	147	
			102	226.0	61/ 59	0.43	112	103	281.0	56/ 55	0.64	155	
			133	249.0	59/ 58	0.49	120	126	298.0	54/ 54	0.71	164	
	5700	583	84	232.5	66/ 62	0.54	107	84	297.3	60/ 59	0.80	147	
			104	254.0	64/ 61	0.59	112	104	321.0	58/ 57	0.89	155	
			126	274.0	62/ 60	0.66	118	126	341.0	57/ 56	0.99	164	
40,80	2200	202	84	143.1	56/ 54	0.10	115	84	167.4	51/ 50	0.15	159	
			91	147.0	55/ 53	0.11	117	93	171.0	50/ 49	0.17	163	
			108	155.0	53/ 52	0.12	122	101	174.0	49/ 49	0.17	167	
	3500	322	84	192.1	60/ 58	0.22	115	84	234.2	54/ 53	0.33	159	
			102	206.0	58/ 56	0.25	121	102	247.0	53/ 52	0.37	168	
			124	220.0	56/ 55	0.27	127	125	259.0	51/ 51	0.41	178	
	4900	451	84	228.6	64/ 60	0.38	115	84	286.6	58/ 56	0.56	159	
			103	248.0	61/ 59	0.42	121	103	306.0	56/ 55	0.62	168	
			125	266.0	59/ 58	0.45	128	125	323.0	55/ 54	0.68	178	
	6300	580	84	255.4	66/ 62	0.53	115	84	326.3	60/ 59	0.79	159	
			104	279.0	64/ 61	0.59	121	105	352.0	58/ 57	0.88	169	
			126	301.0	62/ 60	0.65	128	127	374.0	57/ 56	0.98	179	

Conversions: 2119 SCFM = 1m³/s, 196.8FPM = 1m/s, 3.412 MBH = 1kW, (°F-32) 5/9 = °C, 1 IN.W.C. = 248.8 Pa, 0.4536 kg = 1 lb.

NOTES: 1) Data certified in accordance with ARI Standard 410.

2) Capacity based on 95°F EDB, 74°F EWB, 45°F EWT, 70 GPM.

3) Weight listed is the total weight of the dry coil.

4) Consult Customer Service Department for special coil requirements.

Gas Type [GT]

Model Digit 9

Sterling Engineered Products Heating systems are available from the factory equipped for Natural or LP gas. Natural gas units are equipped for altitudes up to 2,000 ft. (610m) above sea level. Please state altitude if above 2,000 ft. (610m) when placing your order for proper factory settings.

Gas Type [GT]

- 1 - Natural Gas with Standard Solid State Ignition Control
- 2 - LP Gas with 100% Lockout Solid State Ignition Control
- 3 - Natural Gas with 100% Lockout Solid State Ignition Control

Gas Type "3" and Unit Type "PV" is required for IRI (Industrial Risk Insurers) compliance.

Gas Control [GC]

Model Digit 10

In order to meet your most demanding applications from Single Zone Single Stage to Multi Zone Multi Stage to Direct Digital Control (DDC) with turn down ratios as high as 7.5:1 and modulated output, Sterling Engineered Products offers the following factory

installed gas controls. Providing the high quality and performance you've come to rely on with Sterling HVAC Products.



GC - K



GC - L, M, N, P



GC - R, S, T



GC - U, W, X, Y

Gas Control [GC]

- A - One Stage Gas.** Provides On/Off gas control in response to a room or duct thermostat.
- B - Two Stage Gas.** Provides two stages of gas control Low 40% and High 100% rates of fire in response to a room or duct thermostat.
- C - Mechanical Modulation (60° - 100°F).** Modulates from 40% to 100% of the units rated input in response to remote bulb/capillary tube located in the supply air stream. Accurate within 3-5°F of the setpoint this control will maintain discharge air temperature from 60° to 100°F.
- D - Mechanical Modulation (75° - 200°F).** Modulates from 40% to 100% of the units rated input in response to remote bulb/capillary tube located in the supply air stream. Accurate within 3-5°F of the setpoint this control will maintain discharge air temperature from 75° to 200°F.
- F - Mechanical Modulation (60° - 100°F) with Bypass Manifold.** Same as "C" with the addition of a Bypass Manifold. The Bypass Manifold provides 100% fire upon demand typically from a

room thermostat bypassing the modulating valve until room temperature is satisfied then resuming modulated input in response to the remote bulb/capillary tube located in the supply air stream. An additional furnace high limit set to 120°F has also been added to ensure safe operation.

- G - Mechanical Modulation (75° - 200°F) with Bypass Manifold.** Same as "D" with the addition of a Bypass Manifold. The Bypass Manifold provides 100% fire upon demand typically from a room thermostat bypassing the modulating valve until room temperature is satisfied then resuming modulated input in response to the remote bulb/capillary tube located in the supply air stream.
- H - Electronic Modulation with Room Sensing.** Modulates from 100% to 40% of the units rated input in response to the setpoint setting of an electronic room sensor. Electronic Modulation is capable of maintaining discharge temperature within + - 1°F. 60-85°F. range.

J - Electronic Modulation with Duct Sensing. Modulates from 100% to 40% of the units rated input in response to the setting of a remote setpoint and an electronic duct sensor. Electronic Modulation is capable of maintaining discharge air temperature within + - 1°F. 55-90°F. range.

K - Electronic Modulation with Duct Sensing and Override Stat. Same as “J” with the addition of a room override stat. The room override stat signals the electronic controller in the event that room temperature has dropped below its setpoint. In response the electronic control increases the rate of modulated input to the unit in proportion to the difference between sensed room temperature and the setpoint.

L - Electronic Modulation with External 4-20 mA input, furnace one only. Setup for the first furnace in multi furnace units with any additional furnaces being single stage. This Gas Control requires a Direct Digital Controller (DDC) or other external signal source. Modulates from 100% to 40% of the first furnaces rated input in response to an analog input of 4-20 mA from an external controller. Additional furnace sections of the unit are actuated by digital outputs from the external controller based upon the control program.

M - Electronic Modulation with External 4-20 mA input. (All furnaces-capacities 50/80 and 12). This Gas Control requires a Direct Digital Controller (DDC) or other external signal source. Modulates from 100% to 40% of the units rated input in response to an analog input of 4-20 mA from an external controller (choose Digit “L” for 10/40 capacities).

N - Electronic Modulation with External 0-10 VDC input, furnace one only. Same as “L” except a 0-10 VDC input signal is required.

P - Electronic Modulation with External 0-10 VDC input. (All furnaces-capacities 50/80 and 12). Same as “M” except a 0-10 VDC input signal is required (choose Digit “M” for 10/40 capacities).

R - Remote Temperature Control, Two Stage. Provides two stage control utilizing a T775 temperature controller, electronically sensing room or duct temperature and actuating stages base upon programmed setpoints and temperature differentials between stages.

S - Remote Temperature Control, Three Stage. Same as “R” except with three stage control.

T - Remote Temperature Control, Four Stage. Same as “R” except with four stage control.

U - S350 Modular Electronic Control System, Two Stage. Basic system utilizes a controller module with discharge air sensor, setpoint and one stage output, a stage module with differential set point and one stage output and a display module with LCD display for temperature readout. The system stages the units rate of fire base upon sensed discharge air temperature, setpoint setting and differential setting between stages. -30 to 130°F. range.

Note: When utilizing outside and return air with modulating damper refer to Air Control [AC] item “R” for the S350 proportional air control.

W - S350 Modular Electronic Control System, Three Stage. Same as “U” with the addition of a stage module.

X - S350 Modular Electronic Control System, Four Stage. Same as “U” with the addition of two stage modules.

Y - S350 Modular Electronic Control System, Six Stage. Same as “U” with the addition of four stage modules.

Gas Control Reference

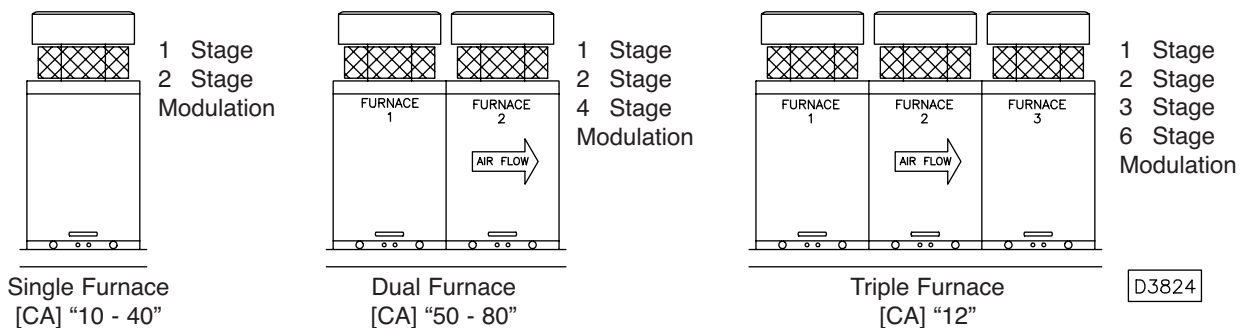

Supply Voltage [SV]

Model Digit 11

The standard Supply Voltages for Sterling Engineered Products are listed below.

- 1 - 115 VAC, Single Phase, 60 Cycle
- 2 - 208 VAC, Single Phase, 60 Cycle
- 3 - 230 VAC, Single Phase, 60 Cycle
- 4 - 208 VAC, Three Phase, 60 Cycle
- 5 - 230 VAC, Three Phase, 60 Cycle
- 6 - 460 VAC, Three Phase, 60 Cycle
- 7 - 575 VAC, Three Phase, 60 Cycle

Motor Type [MT]

Model Digit 12

Blower Motors are available in Open Drip Proof, Totally Enclosed, Premium Efficiency Open Drip Proof, Premium Efficiency Totally Enclosed and Two Speed Open Drip Proof One or Two Winding. Motors are ball bearing type with a resilient base and NEMA frame sizes from 48 to 256T. Windings are Class "B", 1800 RPM with service factors of 1/2—3/4 HP. = 1.25 and 1–15 HP. = 1.15. Motors are in compliance with the Energy Policy Act (EPACT) of 1992.

- 1 - Open Drip Proof Motor. (ODP)
- 2 - Totally Enclosed. (TEFC)
- 3 - Premium Efficiency Open Drip Proof. (PEODP)
- 4 - Premium Efficiency Totally Enclosed. (PETE)
- 5 - 2 Speed 1 Winding Open Drip Proof. (2-1 ODP)
- 6 - 2 Speed 2 Winding Open Drip Proof. (2-2 ODP)

Motor Size [MS]

Model Digit 13

Motors are available from 1/2 to 15 HP. Thermal Protection is automatic for most motors up to 5 HP., a Magnetic Starter with IEC (International Electrotechnical Commission) type over current protection must be used for motors without automatic thermal protection, motors above 5 HP, and all two-speed motors.

- A - 1/2 HP. with Contactor
- B - 3/4 HP. with Contactor
- C - 1 HP. with Contactor
- D - 1 1/2 HP. with Contactor
- E - 2 HP. with Contactor
- G - 3 HP. with Contactor
- H - 5 HP. with Contactor
- J - 1/2 HP. with Magnetic Starter and IEC over current protection.
- K - 3/4 HP. with Magnetic Starter and IEC over current protection.
- L - 1 HP. with Magnetic Starter and IEC over current protection.
- M - 1 1/2 HP. with Magnetic Starter and IEC over current protection.
- N - 2 HP. with Magnetic Starter and IEC over current protection
- P - 3 HP. with Magnetic Starter and IEC over current protection.
- R - 5 HP. with Magnetic Starter and IEC over current protection.
- S - 7 1/2 HP. with Magnetic Starter and IEC over current protection.
- T - 10 HP. with Magnetic Starter and IEC over current protection.
- U - 15 HP. with Magnetic Starter and IEC over current protection.

Note: Refer to Table 16, page 73 for Full Load Ampacity ratings for motors.

Air Inlet Configuration [AI]

Model Digit 14

The Air Inlet Configuration [AI] defines the entering air openings for Sterling Engineered Products. This item does not include dampers and must match the required opening for Air Control and Damper Arrangement [AC]. A horizontal return air feature is offered on air inlet configurations 4 and 5. Refer to accessory [AS] No. A2.

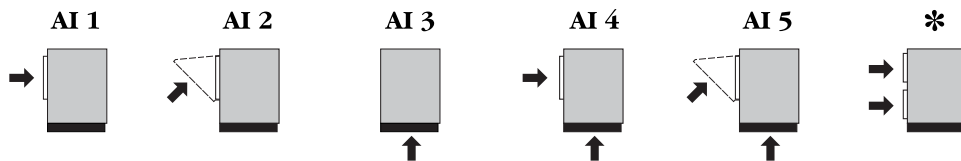

1 - Horizontal Inlet (100% Outside Air or 100% Return Air).

2 - Horizontal Inlet (100% Outside Air or 100% Return Air) with Intake Hood.

3 - Bottom Return Air Opening.

4 - Outside and Return Air Opening.

5 - Outside and Return Air Opening with Intake Hood.

*** Horizontal Outside and Return Air Openings. See Accessories Section [AS] Model Digit # 16 [A2].**

Air Control and Damper Arrangement [AC]

Model Digit 15

A - Outside air damper with 2 Position spring return damper motor. Outside air damper opens upon energizing the unit blower motor.

B - Return air damper with 2 Position spring return damper motor. Return air damper opens upon energizing the unit blower motor.

C - Outside and Return air interlocked dampers with 2 Position spring return damper motor. Outside air damper opens and return air damper closes upon energizing the unit blower motor.

D - Outside and Return air interlocked dampers with Modulating damper motor, Mixed air temperature control and minimum position potentiometer. Outside and return air dampers modulate in response to the mixed air temperature setpoint and allow minimum outside air setting.

E - Outside and Return air interlocked dampers with Modulating spring return damper motor, Mixed air temperature control and minimum position potentiometer. Outside and return air dampers modulate in response to the mixed air temperature setpoint and allow minimum outside air setting. When de-energized outside air dampers close and return air dampers open.

G - Outside and Return air interlocked dampers with Modulating damper motor and Mixed air temperature control. Outside and return air dampers modulate in response to the mixed air temperature setpoint.

H - Outside and Return air interlocked dampers with Modulating spring return damper motor and Mixed air temperature control. Outside and return air dampers modulate in response to the mixed air temperature setpoint. When de-energized outside air dampers close and return air dampers open.

J - Outside and Return air interlocked dampers with Modulating damper motor and positioning potentiometer. Outside and return air dampers open and close with respect to the setting of the positioning potentiometer.

K - Outside and Return air interlocked dampers with Modulating spring return damper motor and positioning potentiometer. Outside and return air dampers open and close with respect to the setting of the positioning potentiometer. When de-energized outside air dampers close and return air dampers open.

Air Control and Damper Arrangement [AC] *continued*

- L - Outside and Return air interlocked dampers with Modulating damper motor. Mixed air temperature control, minimum position potentiometer and Dry Bulb Economizer.** Outside and return air dampers modulate in response to the mixed air temperature setpoint and allow minimum outside air setting. Dampers respond to the economizer when the outside air temperature is within the set point range by opening the outside and closing the return air damper to achieve free cooling effect.
- M - Outside and Return air interlocked dampers with Modulating spring return damper motor. Mixed air temperature control, minimum position potentiometer and Dry Bulb Economizer.** Outside and return air dampers modulate in response to the mixed air temperature setpoint and allow minimum outside air setting. Dampers respond to the economizer when the outside air temperature is within the set point range by opening the outside and closing the return air damper to achieve free cooling effect. When de-energized outside air dampers close and return air dampers open.
- N - Outside and Return air interlocked dampers with Modulating spring return damper motor and Enthalpy Controlled Economizer.** Outside and return air dampers modulate in response to the heat content of sensed mixed air. The air mixture is optimized to provide inlet air with the lowest possible load characteristics in both heating and cooling modes. When de-energized outside air dampers close and return air dampers open.
- P - Outside and Return air interlocked dampers with Modulating damper motor and Atmospheric Pressure sensor.** Outside and return air dampers modulate in response to sensed building pressure, typically maintaining a slightly positive building pressure in order to reduce heat loss due to infiltration.
- Q - Outside and Return air interlocked dampers with Modulating damper motor and CO2 (Carbon Dioxide) Monitor.** Outside and return air dampers modulate in response to the CO2 monitor set point. Monitor is located in the return air stream. On a rise in CO2 level, the outside damper modulates open and the return air damper closes. A decrease in CO2 level modulates the outside air damper closed and opens the return air damper. When the unit is de-energized, the damper motor will close the outside air damper and open the return air damper. Equipped with one normally open contact for alarm light or bell to guard against times of sustained high CO2 levels. CO2 monitor is shipped loose for field installation.
- R - Outside and Return air interlocked dampers with Modulating spring return damper motor and S350 Proportional Mixed air control.** Outside and return air dampers modulate in response to the mixed air temperature setpoint, and allow minimum outside air setting. When de-energized outside air dampers close and return air dampers open.
- S - Outside and Return air interlocked dampers with Modulating damper motor and 0-10VDC or 4-20mA input.** Requires an external input signal from a Direct Digital Controller (DDC). Provides proportional control from a building management system or electronic controller based upon programmed parameters.
- T - Outside and Return air interlocked dampers with Modulating spring return damper motor and 0-10VDC or 4-20mA input.** Requires an external input signal from a Direct Digital Controller (DDC). Provides proportional control from a building management system or electronic controller based on programmed parameters. When de-energized outside air dampers close and return air dampers open.
- U - ASHRAE Cycle I,** Outside and Return dampers with 2 Position spring return damper motor and warm-up thermostat. When energized dampers open in response to the warm-up thermostat preventing cold air starts.
- W - ASHRAE Cycle II,** Outside and Return air interlocked dampers with Modulating spring return damper motor. Mixed air temperature control, minimum position potentiometer and warm-up thermostat. Outside and return air dampers modulate in response to the mixed air temperature setpoint and allow minimum outside air setting once the warm-up thermostat has been satisfied. When de-energized outside air dampers close and return air dampers open.
- X - ASHRAE Cycle III,** Outside and Return air interlocked dampers with Modulating spring return damper motor. Mixed air temperature control and warm-up thermostat. Outside and return air dampers modulate in response to the mixed air temperature setpoint once the warm-up thermostat has been satisfied. When de-energized outside air dampers close and return air dampers open.
- Y - Manual Outside and Return air dampers.** Dampers are locked into position utilizing a manual quadrant for field adjustment.

Accessories [AS]

Model Digit 16/+

Mechanical Accessories

- A1- Moisture Eliminators.** Use in place of the bird screen with an Outside Air Hood. This item includes an electrically interlocked differential pressure switch with indicator lamp in case of blockage.
- A2- Horizontal Return.** Locates the return air opening under the outside air opening location. For units with both Outside Air and Return Air openings [AI] Model digit # 14 (4 or 5). Includes moisture eliminators as standard when [AI]-5 is chosen.
- A3- Low Leak Damper.** This item includes vinyl blade edge seals with a standard opposed blade galvanized steel damper and neoprene nylon bushings. For Outside Side Air Inlet only.
- A5- 409 Stainless Steel Drip Pan.** Replaces the standard aluminized steel furnace drip pan.

- A6- High Altitude Unit.** Unit is orificed for altitudes above 2000 feet*. 2 stage units include a factory installed delay timer, allowing the unit to initially fire at 100% for 10 sec. then drop back to low fire and respond to thermostat demand.

***Note:** Specify altitude when over 2000 ft. (610m.).

- A7- High Pressure Regulator.** Required where main line pressure exceeds 14" W.C. (psig) and not over 2 psig. One regulator per furnace required, shipped separately.

- A8- Input Derate**.** Unit is derated up to 50% for specific design applications.

****Note:** Specify altitude when over 2000 ft. (610m.)
Unit performance must be adjusted for percentage of derate.

Filters

- B1- 1 in. Washable Filters.** (Standard)
- B2- 2 in. Washable Filters.**
- B3- 2 in. Throwaway Filters.**
- B4- 1 in. High Efficiency 30% Filters.**
- B5- 2 in. High Efficiency 30% Filters.**

Capacity [CA]	10,15	20, 25, 50	30, 35, 60, 70	40, 80,12
Rooftop Arrangement [RA] B,C,D,E,M,N,P,R (Qty.)Filter Size	(4)16 X 20	(4)20 X 20	(4)16 X 20 (2)20 X 20	(6)20 X 20
Rooftop Arrangement [RA] G,J,K,L,S,T,U,W (Qty.)Filter Size	(8)16 X 20	(8)20 X 20	(8)16 X 20 (4)20 X 20	(12)20 X 20

Evaporative Cooler Accessories

- C1- Fill & Drain Kit.** Includes 3 way valve and relay for automatic fill and drain for Evaporative Cooling units. Field installed.
- C2- 12 in. CELdek® Media.** Optional high efficiency 12 in. media replaces standard 8 in. media
- C3- Freezestat.** Automatic shutoff and drain upon meeting outside air setpoint when used with "Fill and Drain kit".

- C4 - 8 in. Glasdek®.** Optional 8 in. GLASdek® evaporative cooler media is available in lieu of the standard 8 in. CELdek®. GLASdek® media is manufactured from a wettable fiberglass and is designed for applications requiring UL900 Class II fire rating.

- C5 - 12 in. Glasdek®.** Optional 12 in. GLASdek® evaporative cooler media is available in lieu of the standard 8 in. CELdek®. GLASdek® media is manufactured from a wettable fiberglass and is designed for applications requiring UL900 Class II fire rating.

Time Clocks

- D1- 7 Day Time Clock.** Provides single pole double throw (SPDT) relay output at setpoint time with Maximum 6 setpoints per day, field installed.

- D2- 24 Hour Time Clock.** Provides single pole double throw (SPDT) relay output at setting time with Maximum 12 setpoints per day, field installed.



Electrical Accessories

E1- Clogged Filter Switch. Factory installed differential pressure switch with clogged filter indicator lamp located in the main electrical cabinet.

E2- Ground Fault Convenience Outlet 115VAC. G.F.I. outlet manual reset with weatherproof enclosure, field installed.



AS - E3



AS - G3



AS - G4



AS - G5

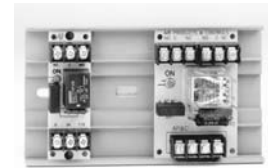

AS - J2 AS - J3

E3- Remote Control Panel. Wall mounted and distinctively styled the “Sterling Remote Panel” offers 6 LED status lamps with System On/Off, Fan Auto/On, Heat Auto/Off, Cool Auto/Off, Auxiliary On/Off switching and Modulating damper potentiometer mounting. Designed for E-Z Installation with plug-in terminal block wiring and wall mounting bracket. Field installed. (Auxiliary On/OFF may be used with Evaporative Cooler Fill & Drain Kit or exhaust fan) [6-1/4" W x 3-3/4" H x 1-3/8" D]

E4- Manual Blower Switch. Factory installed in the electrical cabinet to provide manual blower operation.

Duct and Room Thermostats

F1- One Stage Duct Thermostat. Field installed, single pole double throw switching. 55-175°F. setpoint range. [2" W x 5-5/8" H x 2-7/16" D]

F2- Two Stage Duct Thermostat. Field installed, single pole double throw switching. 55-175°F. setpoint range. [2" W x 5-5/8" H x 2-7/16" D]

G1- T87F Thermostat with Subbase. Single stage heating thermostat. Subbase includes fan switching relay. Standard round styling suitable for any decor. 50-100°F. range.

G2- T87F Thermostat with Subbase & Guard. Same features as “G1” except a tamper proof guard is included.

G3- T834H Sterling Thermostat with Subbase. Single stage heating thermostat with fan switch. Manufactured exclusively for Sterling with the “Sterling” logo embossed on the face plate. 55-95°F. range. [3-1/2" W x 4-3/4" H x 1-3/8" D]

G4- T7300 Programmable Commercial Thermostat. Provides 7 day programmability for 2 stages of heating and 2 stages of cooling. With Heat, Off, Cool, Auto system switching 4 time periods per day for occupied and unoccupied modes with 3 hour override of unoccupied mode. Automatic Heat-Cool changeover. Includes fan and heating relays. 45-95°F. range. [8" W x 4-5/8" H x 1-3/4" D]

G5- T874 Two Stage Thermostat. 2 stage heating and 2 stage cooling with system and fan switching and built in 12°F heating / cooling differential. Includes fan and relay. 42-88°F. range. [5-5/8" W x 3-1/2" H x 2-1/8" D]

G6- TG511 Locking Thermostat Cover. Universal locking thermostat cover for use with all thermostats listed.

Freeze and Fire Protection

- H1- Return Firestat.** 110°-290°F setting range with single pole double throw (SPDT) output. The Return Firestat is electrically interlocked to shut down the unit upon reaching the setpoint with manual reset. Factory mounted in the return air stream. This item is utilized as a reverse air flow switch and included as standard with Sterling Packaged Rooftop units. Order with Rooftop Arrangement [RA] "A" when applicable.
- H2- Supply Firestat.** 110°-290°F setting range with single pole double throw (SPDT) output. The Supply Firestat is electrically interlocked to shut down the unit upon reaching the setpoint with manual reset. Factory mounted in the supply air stream.
- H3- Time Delay Freezestat.** 30°-58°F setting range with single pole double throw (SPDT) output. Time delay adjustment range - 1 minute to 5 minutes. The Freezestat is electrically interlocked to ensure minimum discharge air temperature. Factory mounted in the electrical compartment.
- H4- Ambient Lockout.** Factory mounted. Disengages duct furnace(s) from firing in times of mild ambient temperatures.

Interlock Relays

- J1- 24 Volt DPDT Relay.** Plug-in, Type 2, Form C relay with 24 volt coil and double pole double throw 10 amp. contacts. This relay plugs in to the Main Connection PC board in the electrical cabinet. Included with Packaged units including an evaporative cooler and outside return air dampers (Rooftop Arrangements [RA] "D-E") or may be utilized as an exhaust fan interlock. When energized at terminal "K2" of the main connection board, the blower is engaged and outside air dampers are opened to 100% position. Factory installed.
- J2- 24/115 Volt SPDT Relay.** This relay has selectable coil voltage of 24 or 115 volts and single pole double throw 10 amp contacts with LED On indicator lamp. Relay is utilized as an auxiliary relay when "J1" does not apply for exhaust fan interlock or digital interface with an external control. Factory mounted and wired when applicable.

Limits and Indicator Lamps

- K1- Manual Reset High Limit Switch.** This factory installed, non-cycling type limit opens on temperature rise at 200°F and disengages heating.
- K2- High / Low Gas Pressure Limits.** High / Low gas pressure limits disengage heating upon detecting either low line pressure or high manifold pressure. Factory Installed.
- K3- Status Lamps.** Long life factory installed LED lamps located in the electrical cabinet. The status lamps are designed as a troubleshooting aid and setup for indicating Power On, Fan On, Heating energized at furnace one, two, three and cooling energized when applicable.
Note: Blocked inlet and Clogged filter indicator lamps are standard with "A1" and "E1".
- K4- Fan Time Delay.** The Solid State fan time delay is standard with all packaged rooftop arrangements except Rooftop Arrangement [RA] "A" duct furnace only. The fan time delay provides a 60 second delay on and 120 second delay off, for blower operation.
- K5- Air Flow Prove Switch.** Field installed. A Dwyer 1910-0 pressure switch suitable for duct or plenum mounting, with a range of 0.15 - 0.5 inches W.C. is provided.

- J3 - 24/115/230 Volt DPDT Relay.** This relay has selectable coil voltage of 24, 115 or 230 volts and double pole double throw 10 amp contacts. Relay is utilized as an auxiliary relay for general purpose duty. Factory mounted and wired when applicable.
Note: Relays "J2" and "J3" are shipped loose unless otherwise specified.
- J4 - 24 Volt 4PDT Relay.** This relay has a coil voltage of 24 volts and four pole double throw 10 amp contacts. Relay is included as standard for packaged units with an Evaporative Cooler or Coil Cabinet may be utilized as an auxiliary relay for general purpose duty. Factory mounted and wired when applicable.
Note: Relay "J4" is shipped loose unless otherwise specified.

Disconnect Switches (NEMA-3R)

- L1- 30 Amp. Fused Disconnect. Field installed.
- L2- 30 Amp. Non Fused Disconnect. Field installed.
- L3- 60 Amp. Fused Disconnect. Field installed.
- L4- 60 Amp. Non Fused Disconnect. Field installed.

Convenience Accessories

N1- Hinged Access Doors: Hinged doors are mounted to the access side of the standard Blower / Filter / Damper cabinet and High CFM Filter / Damper and Blower cabinets in lieu of the standard removable access doors. The hinged doors include dual, quick opening tool-less latches and full perimeter gasketing to assure a water tight seal. Door stops are included to guard against closure while open. The remaining Duct Furnace(s) and Supply Plenum cabinets (if applicable) are supplied with a standard removable door.

N2- Through-The- Base Utility Penetrations:

Through the base utility penetrations allows the gas, electric and coil connections to be passed through base and curb of the unit. This results in a reduction in the number of roof penetrations, thus enhancing the integrity of the roofing materials.

N3- Service Convenience Package: Includes a factory mounted switch type fused disconnect and GFI convenience outlet mounted behind a hinged access door on the units' blower section. Both items are accessible from the outside of the unit via a weather proof hinged access door. This accessory also includes options number N1 and N2.

N6- Double Wall Cabinet Construction: consists of a 24 gauge inner liner wall with 1" 1-1/2 LB density insulation. As an added advantage, Sterling includes hinged access doors (current accessory option AS-N1) standard with the double wall option. Available on the filter / damper, blower, coil and plenum cabinets only.

Component Locations

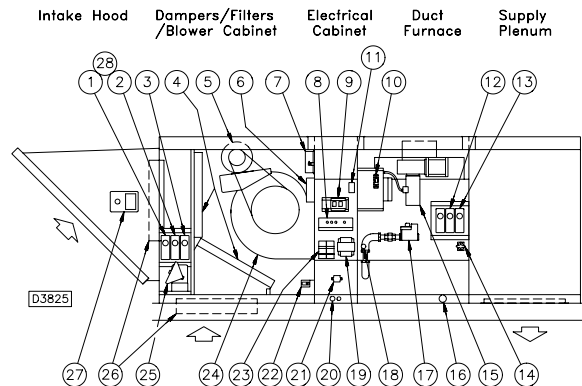

- | | |
|--|------------------------------------|
| 1. Mixed Air Controller | 14. Primary Safety Limit |
| 2. Return Firestat | 15. Power Venter Motor |
| 3. Economizer | 16. Gas Piping Inlet |
| 4. Filters | 17. Gas Valve |
| 5. Blower Motor | 18. High Limit Safety Switch |
| 6. Reverse Air Flow Switch | 19. Transformer |
| 7. Clogged Filter Switch | 20. Electrical Wiring Inlet |
| 8. High Voltage Barrier and Lamp and Circuit Breaker Mount | 21. High Voltage Terminal Block |
| 9. Main Connection Board with Fan Time Delay and Function Relays | 22. Door Safety Switch |
| 10. Power Venter Relay | 23. Contactor |
| 11. Time Delay Freezestat | 24. Centrifugal Blower |
| 12. Supply Firestat | 25. Damper Motor |
| 13. Duct Thermostat | 26. Outside and Return Dampers |
| | 27. Enthalpy Controlled Economizer |
| | 28. Ambient Lockout |

[Power Vent "PV" unit shown]

Air Handler and Evaporative Cooler Selection

AH - Air Handler
EV - Evaporative Cooler

The following section contains stand-alone Air Handler” and “Evaporative Cooler” information. It is necessary to complete the first 7 digits of the model from this section then refer to page 35 - 48 for model digits 8 - 16+.

Model Number items that do not apply such as Furnace Type [FT] digit 5, Furnace Material [FM] digit 6, Gas Type [GT] digit 9 and Gas Control [GC] digit 10 need to be filled in with a “0” none selection.

Select Unit Type

Unit Type [UT] Digits 1&2

- AH** - Air Handler
- EV** - Evaporative Cooler

Select Capacity

Capacity [CA] Digit 3,4

- 10 - 100 MBH
- 15 - 150 MBH
- *20 - 200 MBH
- 25 - 250 MBH
- 30 - 300 MBH
- 35 - 350 MBH
- *40 - 400 MBH
- *Air Handler Sizes*

Furnace Type does not apply

Furnace Type [FT] Digit 5
0 - None

Furnace Material does not apply

Furnace Material [FM] Digit 6
0 - None

Select Rooftop Arrangement

Rooftop Arrangement [RA] Digit 7
0 - None For Evaporative Coolers

See Page 50 for Rooftop Arrangement [RA] Digit 7 for Air Handlers and page 57 for Evaporative Cooler Information.

Packaged Rooftop Arrangements

Air Handler

Unit Type [UT] Model Digits 1&2

Rooftop Arrangement [RA] Model Digit 7

Sterling Packaged Rooftop Units are design certified to UL-1995 standard for heating cooling and ventilating equipment. Units are available in one of 8 standard arrangements (Rooftop Arrangements [RA], Model digit 7). Air Handler units (Unit Type [UT] "AH") are suitable for commercial, institutional and industrial applications where external system pressure losses are as high as 3 in. W.C.

Rooftop Arrangements are divided into two classifications "Standard" and "High-CFM" Blower types. The "Standard" Air Handler units (Rooftop Arrangement [RA] "M,N,P,R") have a CFM range of 1,500 - 8,000 CFM (0.7 - 4.0 m³/s). The Standard Air Handler arrangement consists of a blower cabinet that houses dampers, filters and blower in one cabinet; an optional Evaporative cooling unit with standard 8 or optional 12 in. media may also be included.

The "High-CFM" Air Handler Units (Rooftop Arrangement [RA] "S & T") have a range of 3,000-14,000 CFM (1.4 - 6.6 m³/s). High CFM Air Handler units utilize a separate Damper/Filter cabinet with a "V" bank filter arrangement and a blower cabinet. Rooftop Arrangements "U & W" include an additional Cooling Coil cabinet capable of up to 20 tons and a CFM range of 1,600 - 6,300 (0.8 - 3.0 m³/s). This coil cabinet may also be suitable for field installations of heating coils.

Both "Standard" and "High-CFM" Air Handler arrangements may also include a downturn Supply Air Plenum, Outside Air Intake Hood with standard Bird

Screen or optional moisture eliminators and a Roof Curb. All arrangements are rail mounted.

For your safety and convenience all Sterling Packaged Air Handler Units include a 24 Volt control circuit, 24 Volt in line Circuit Breaker, Blower Door Interlock Switch with Terminal Block Wiring. All wiring is processed at our factory as harness assemblies and each wire is permanently stamped with its wire number.

All cabinets are constructed of rugged 18 ga. material and painted Sterling gray. The modular design of the cabinetry ensures reliability as well as serviceability with quick-release door latches, water tight sealed seams, insulated blower filter and plenum cabinets and down-rolled (hat type) rails mount tightly over the roof curb.

Rooftop Arrangements [RA]

- M - Air Handler (STANDARD)
- N - Air Handler (STANDARD) / Plenum
- P - Air Handler (STANDARD) / Evap. Cooling
- R - Air Handler (STANDARD) / Evap. Cooling / Plenum
- S - Air Handler (HIGH-CFM)
- T - Air Handler (HIGH-CFM) / Plenum
- U - Air Handler (HIGH-CFM) / Coil Cabinet
- W - Air Handler (HIGH-CFM) / Coil Cabinet / Plenum



Standard Air Handler Blower



High-CFM Air Handler Blower

Packaged Rooftop Arrangement Reference

Air Handlers, Unit Type [UT] (AH)

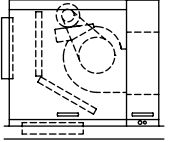
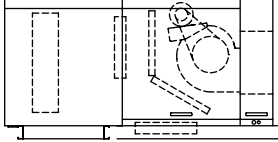
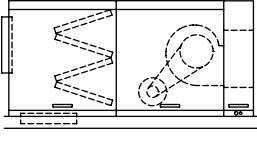
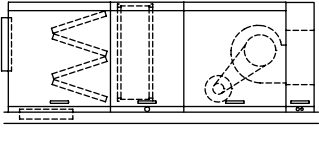
Standard Blower Rooftop Arrangements M, N	Standard Blower w/Evap. Rooftop Arrangements P, R	High CFM Blower Rooftop Arrangements S, T	High CFM Blower w/Cooling* Rooftop Arrangements U, W
			
<p>Capacity 20, 40</p> <p>20 - 1,500-6,000 CFM, 1/2-5 HP. 40 - 4,000-8,000 CFM, 1/2-5 HP.</p> <p>ESP. 0.1 - 3.0 in. WC. Tables # 10, 4</p>	<p>Capacity 20, 40</p> <p>20 - 1,500-6,000 CFM, 1/2-5 HP. 40 - 4,000-8,000 CFM, 1/2-5 HP.</p> <p>ESP. 0.1 - 3.0 in. WC. Tables # 10, 4</p>	<p>Capacity 20, 40</p> <p>20 - 3,000-8,000 CFM, 3/4-10 HP. 40 - 5,000-14,000 CFM, 3/4-15 HP.</p> <p>ESP. 0.1 - 3.0 in. WC. Tables # 11, 7</p>	<p>Capacity 20, 40</p> <p>20 - 1,600-4,400 CFM, 3/4-10 HP. 40 - 2,100-6,300 CFM, 3/4-15 HP.</p> <p>ESP. 0.1 - 3.0 in. WC. Tables # 11, 7, 8, 9</p>

* The maximum CFM for Rooftop Arrangements U and W is 6,300 (3.0 m³/s). A two speed motor may be utilized for non-cooling air flow up to 14,000 CFM (6.6 m³/s).

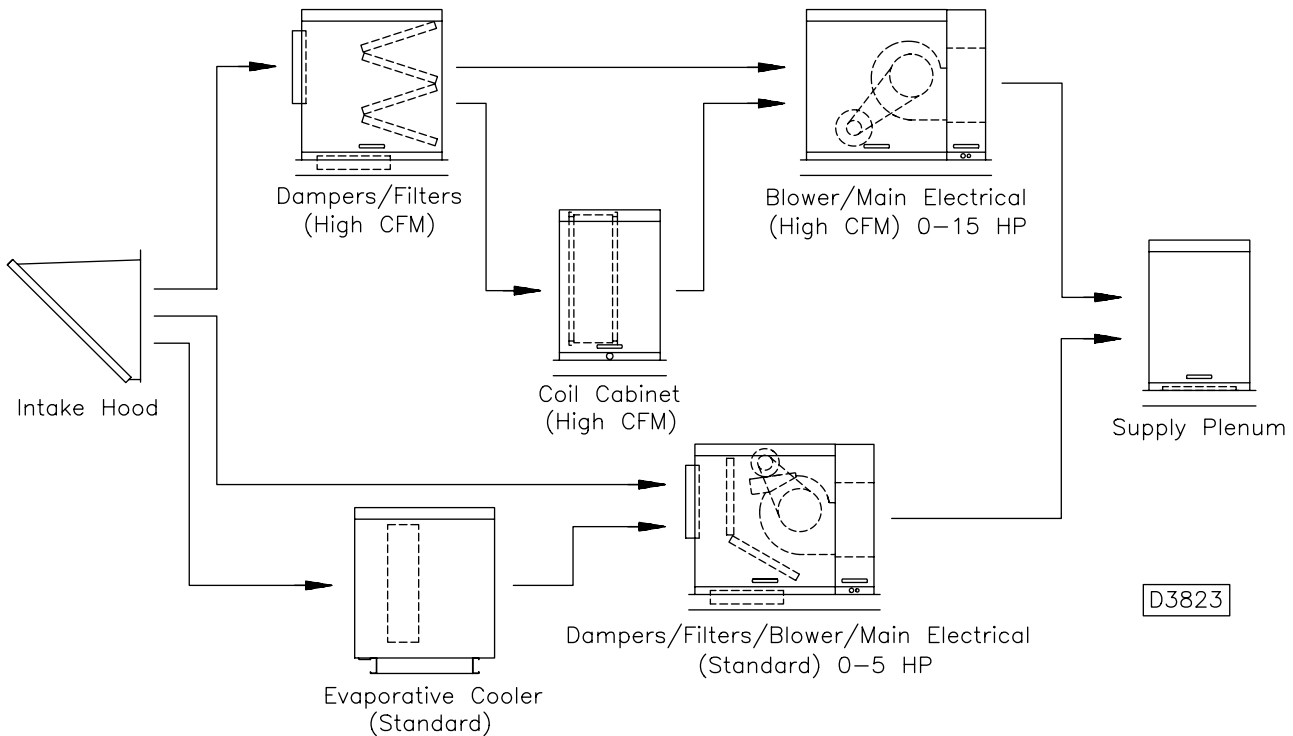

Air Handler Performance -- Table 10 Rooftop Arrangement [RA] (M,N,R,P)



Total Static Pressure (Inches of Water)

Capacity CFM	0.2		0.4		0.6		0.8		1		1.2		1.4		1.6		1.8		2		2.2		2.4		2.6		2.8		3					
	RPM	BHP	RPM	BHP	RPM	BHP	RPM	BHP	RPM	BHP	RPM	BHP	RPM	BHP	RPM	BHP	RPM	BHP	RPM	BHP	RPM	BHP	RPM	BHP	RPM	BHP	RPM	BHP	RPM	BHP	RPM	BHP		
1,500	395	0.12	530	0.19	645	0.27	750	0.35	845	0.44	930	0.54	1010	0.65	1085	0.76	-	-	-	-	-	-	-	-	-	-	-	-	-	-	-	-		
2,000	435	0.22	550	0.3	655	0.4	750	0.49	835	0.59	915	0.7	995	0.81	1065	0.93	1135	1.06	1180	1.18	1240	1.31	1295	1.44	1350	1.57	1405	1.7	1455	1.83	1505	1.96		
3,000	555	0.61	630	0.71	710	0.83	790	0.96	865	1.09	935	1.23	1000	1.37	1065	1.51	1125	1.66	1180	1.81	1240	1.96	1295	2.12	1350	2.28	1405	2.45	1455	2.62	1505	2.79	1555	2.96
4,000	700	1.33	750	1.47	805	1.61	865	1.75	930	1.9	990	2.07	1045	2.25	1105	2.43	1160	2.61	1210	2.8	1260	2.98	1310	3.17	1360	3.35	1405	3.54	1455	3.74	1505	3.94	1555	4.14
5,000	855	2.51	890	2.68	930	2.85	975	3.02	1020	3.19	1070	3.37	1120	3.55	1170	3.75	1220	3.96	1265	4.18	1310	4.4	1360	4.63	1400	4.86	-	-	-	-	-	-	-	-
5,500	935	3.3	965	3.49	1000	3.67	1040	3.86	1080	4.05	1120	4.24	1165	4.43	1210	4.63	1255	4.84	-	-	-	-	-	-	-	-	-	-	-	-	-	-		
6,000	1015	4.25	1040	4.45	1075	4.65	1105	4.85	-	-	-	-	-	-	-	-	-	-	-	-	-	-	-	-	-	-	-	-	-	-	-	-		
4,000	450	0.46	565	0.64	670	0.82	760	1.01	845	1.22	930	1.43	1005	1.66	1075	1.9	1140	2.15	1205	2.42	-	-	-	-	-	-	-	-	-	-	-	-	-	-
5,000	510	0.79	605	0.99	700	1.21	785	1.44	860	1.67	935	1.91	1005	2.16	1070	2.42	1135	2.69	1200	2.97	-	-	-	-	-	-	-	-	-	-	-	-	-	-
6,000	575	1.28	655	1.49	740	1.73	815	2	885	2.28	955	2.56	1020	2.84	1085	3.12	1140	3.41	1200	3.71	1255	4.02	1315	4.34	1365	4.67	1420	5	-	-	-	-	-	-
7,000	650	1.95	715	2.19	785	2.44	855	2.73	920	3.04	985	3.36	1045	3.68	1105	4	1160	4.33	1215	4.66	1270	4.99	-	-	-	-	-	-	-	-	-	-	-	-
8,000	725	2.83	780	3.1	840	3.38	905	3.67	965	3.99	1025	4.34	1080	4.71	-	-	-	-	-	-	-	-	-	-	-	-	-	-	-	-	-	-	-	-

NOTES: 1. Refer to Table 4, pages 18 and 19 for Accessory Pressure Loss(es).

2. Brake horsepower (BHP) includes drive losses.

3. "Total External Pressure (TEP)" is the sum of the units' Internal Accessory pressure loss(es) from Table 4 plus the external static pressure.

Air Handler Performance -- Table 11 Rooftop Arrangement [RA] (S,T,U,W)

The maximum CFM for Rooftop Arrangements U and W Cooling Coil is 6,300 (3.0 m³/s). A two speed motor may be utilized for non-cooling air flow up to 14,000 CFM (6.6 m³/s).



Total Static Pressure (Inches of Water)

Capacity CFM	0.2		0.4		0.6		0.8		1		1.2		1.4		1.6		1.8		2		2.2		2.4		2.6		2.8		3					
	RPM	BHP	RPM	BHP	RPM	BHP	RPM	BHP	RPM	BHP	RPM	BHP	RPM	BHP	RPM	BHP	RPM	BHP	RPM	BHP	RPM	BHP	RPM	BHP	RPM	BHP	RPM	BHP	RPM	BHP	RPM	BHP		
3,000	455	0.52	610	0.82	670	0.93	730	1.06	785	1.21	840	1.37	890	1.53	940	1.69	985	1.86	1030	2.02	1075	2.19	-	-	-	-	-	-	-	-	-	-		
4,000	575	1.13	610	1.24	645	1.35	680	1.47	720	1.61	760	1.76	800	1.92	840	2.08	880	2.24	920	2.4	960	2.58	1000	2.74	1040	2.9	1080	3.06	1120	3.22	1160	3.38		
5,000	695	2.11	730	2.27	760	2.41	790	2.55	815	2.68	840	2.83	870	2.99	905	3.17	940	3.36	980	3.56	1020	3.76	1060	3.95	1100	4.15	1140	4.35	1180	4.55	1220	4.75	1260	4.95
6,000	820	3.54	850	3.75	880	3.94	905	4.12	930	4.28	950	4.44	975	4.6	1000	4.77	1020	4.96	1045	5.15	1070	5.36	1100	5.59	1130	5.82	1160	6.06	1190	6.3	1220	6.58	1250	6.86
7,000	945	5.51	975	5.78	1000	6.02	1025	6.24	1050	6.45	1070	6.64	1090	6.83	1105	7.02	1125	7.21	1145	7.4	1165	7.6	1185	7.81	1205	8.04	1225	8.28	1250	8.52	1270	8.8		
7,500	1005	6.74	1035	7.03	1060	7.3	1085	7.54	1110	7.77	1130	7.99	1150	8.19	1165	8.4	1185	8.59	1200	8.8	1215	9	1235	9.21	1255	9.43	1270	9.66	1290	9.91	-	-	-	-
8,000	1070	8.13	1095	8.45	1125	8.74	1145	9.01	1170	9.27	1190	9.5	1210	9.73	1225	9.95	-	-	-	-	-	-	-	-	-	-	-	-	-	-	-	-		
5,000	405	0.67	465	0.84	540	1.03	610	1.25	675	1.5	740	1.77	800	2.04	855	2.31	905	2.59	955	2.88	-	-	-	-	-	-	-	-	-	-	-	-	-	-
6,000	470	1.08	510	1.26	570	1.48	630	1.71	690	1.95	745	2.22	800	2.53	855	2.85	905	3.17	955	3.5	-	-	-	-	-	-	-	-	-	-	-	-	-	-
8,000	595	2.4	630	2.62	665	2.84	700	3.1	745	3.39	790	3.71	835	4.01	880	4.33	925	4.66	965	5.01	-	-	-	-	-	-	-	-	-	-	-	-	-	-
10,000	730	4.52	760	4.81	795	5.07	810	5.34	840	5.64	870	5.96	900	6.31	935	6.67	975	7.1	1010	7.49	1045	7.88	1085	8.27	1120	8.66	-	-	-	-	-	-	-	-
12,000	860	7.64	890	8.01	915	8.35	935	8.67	960	8.99	980	9.32	1000	9.66	1025	10.04	1050	10.44	1080	10.88	1110	11.33	1140	11.8	1170	12.28	-	-	-	-	-	-	-	-
14,000	995	11.97	1020	12.41	1045	12.83	1065	13.22	1085	13.6	1105	13.97	1120	14.34	1140	14.73	-	-	-	-	-	-	-	-	-	-	-	-	-	-	-	-	-	-

NOTES: 1. Refer to Table 7, pages 24 and 25 for Accessory Pressure Loss(es).

2. Brake horsepower (BHP) includes drive losses.

3. "Total External Pressure (TEP)" is the sum of the units' Internal Accessory pressure loss(es) from Table 4 plus the external static pressure.

Dimensional Data – Air Handlers

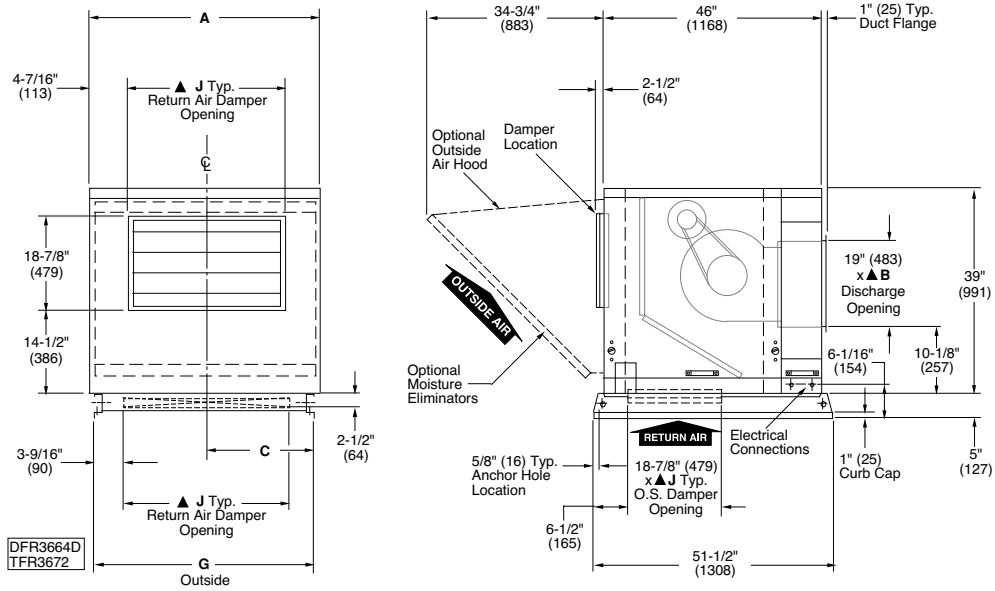

Rooftop Arrangement [RA] “M”

Capacities [CA] 20 or 40 Unit Sizes (Right hand service access shown)

CAPACITY	A	B	C	G	▲J
20	43- 7/8 (1114)	23-13/16 (605)	21-15/16 (557)	42- 1/16 (1068)	35 (889)
40	60- 3/8 (1534)	45-13/16 (1164)	30- 3/16 (767)	58- 9/16 (1487)	51- 1/2 (1308)

NOTES: Dimensions are in inches. Dimensions in parenthesis are in millimeters.

▲ “J” Dimension is an outside dimension for return air dampers.

▲ “J” Dimension is also an inside dimension for the supply air opening (without damper).

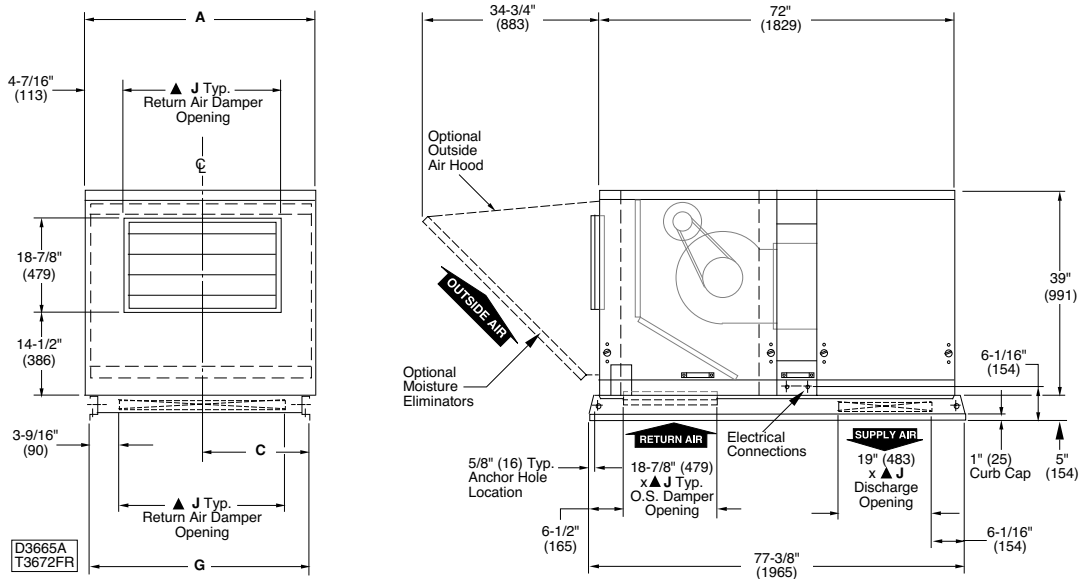

Rooftop Arrangement [RA] “N”

Capacities [CA] 20 or 40 Unit Sizes (Right hand service access shown)



Dimensional Data – Air Handlers

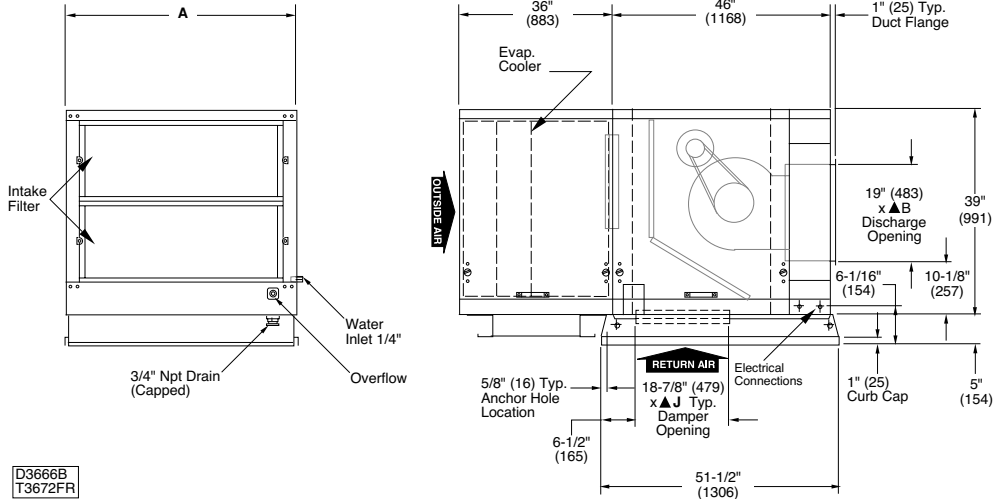

D3666B
T3672FR

Rooftop Arrangement [RA] "P"

Capacities [CA] 20 or 40 Unit Sizes (Right hand service access shown)

CAPACITY	A	B	C	G	\blacktriangle J
20	43- 7/8 (1114)	23-13/16 (605)	21-15/16 (557)	42- 1/16 (1068)	35 (889)
40	60- 3/8 (1534)	45-13/16 (1164)	30- 3/16 (767)	58- 9/16 (1487)	51- 1/2 (1308)

NOTES: Dimensions are in inches. Dimensions in parenthesis are in millimeters.

\blacktriangle "J" Dimension is an outside dimension for return air dampers.

\blacktriangle "J" Dimension is also an inside dimension for the supply air opening (without damper).

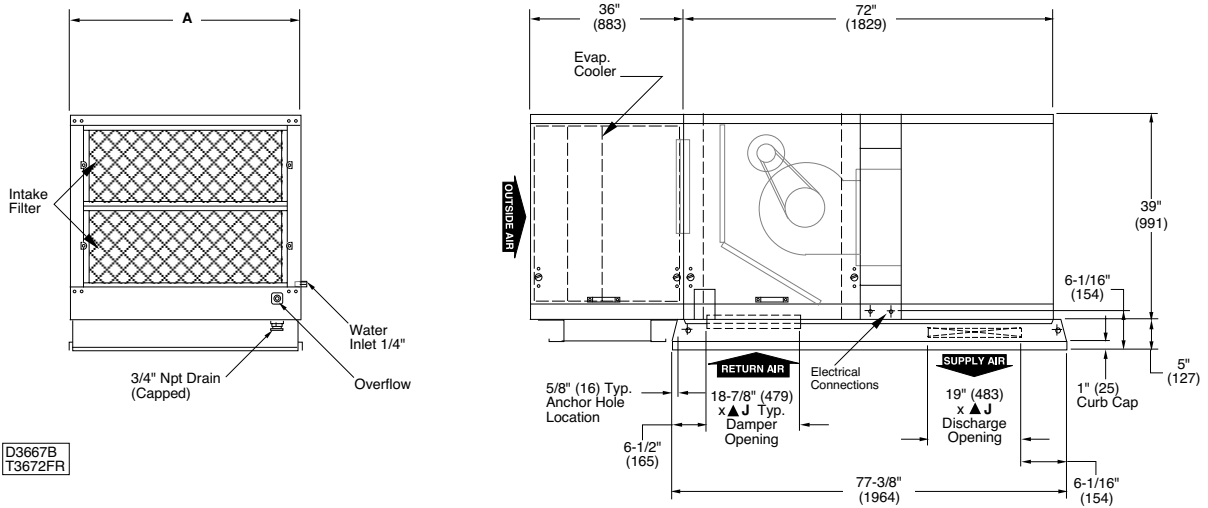

D3667B
T3672FR

Rooftop Arrangement [RA] "R"

Capacities [CA] 20 or 40 Unit Sizes (Right hand service access shown)

Dimensional Data – Air Handlers

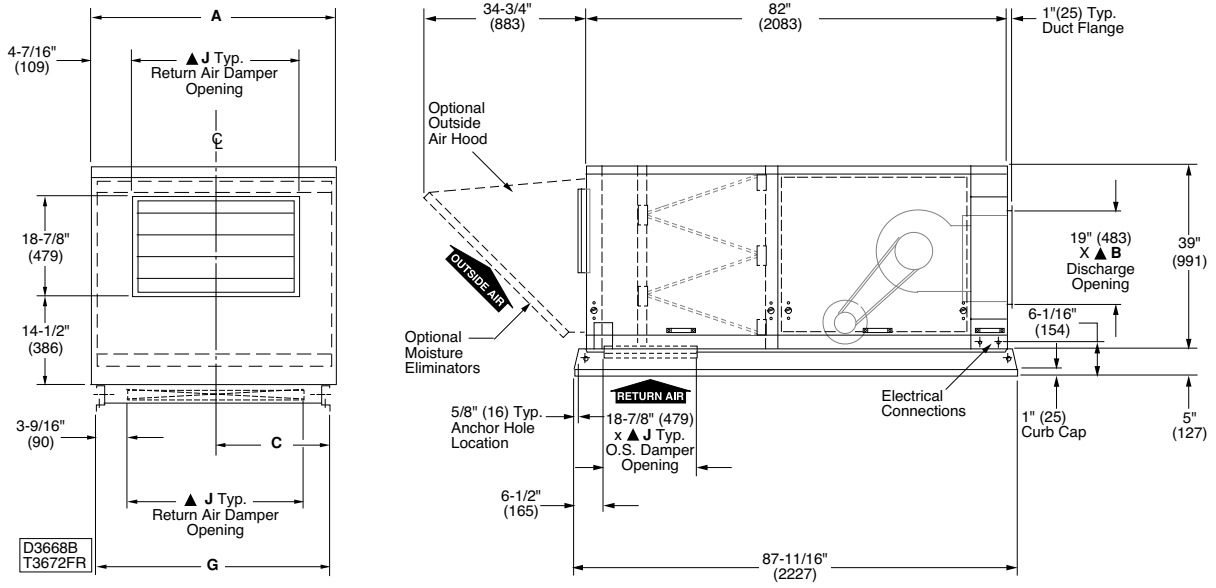

Rooftop Arrangement [RA] "S"

Capacities [CA] 20 or 40 Unit Sizes (Right hand service access shown)

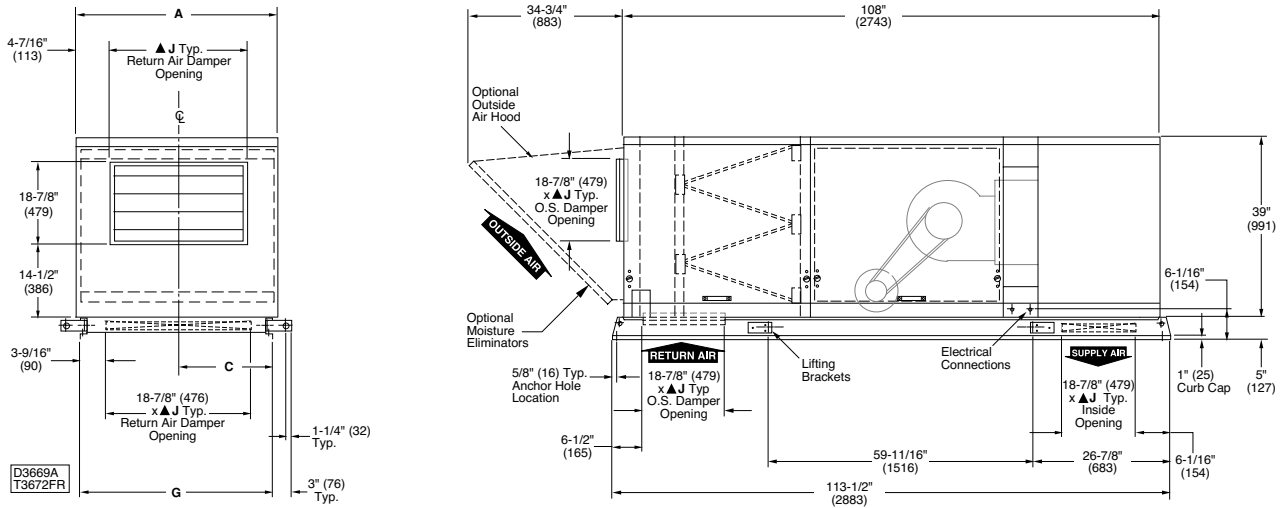

Rooftop Arrangement [RA] "T"

Capacities [CA] 20 or 40 Unit Sizes (Right hand service access shown)

Refer to page 54 for tabulated dimensional data.

Dimensional Data – Air Handlers

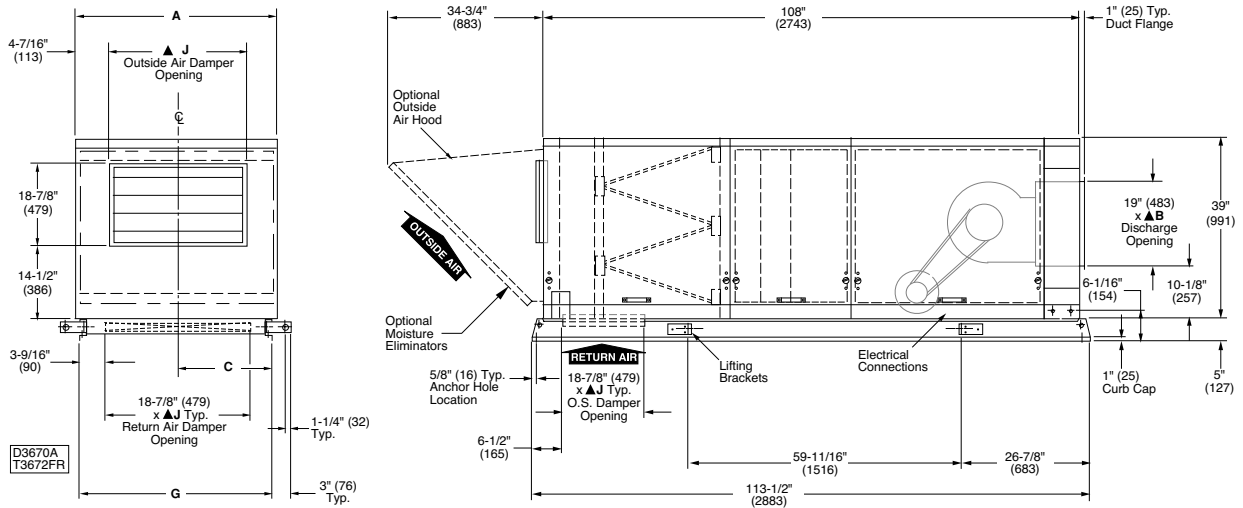

Rooftop Arrangement [RA] "U"

Capacities [CA] 20 or 40 Unit Sizes (Right hand service access shown)

CAPACITY	A	B	C	G	▲J
20	43- 7/8 (1114)	23-13/16 (605)	21-15/16 (557)	42- 1/16 (1068)	35 (889)
40	60- 3/8 (1534)	45-13/16 (1164)	30- 3/16 (767)	58- 9/16 (1487)	51- 1/2 (1308)

NOTES: Dimensions are in inches. Dimensions in parenthesis are in millimeters.

▲ "J" Dimension is an outside dimension for return air dampers.

▲ "J" Dimension is also an inside dimension for the supply air opening (without damper).

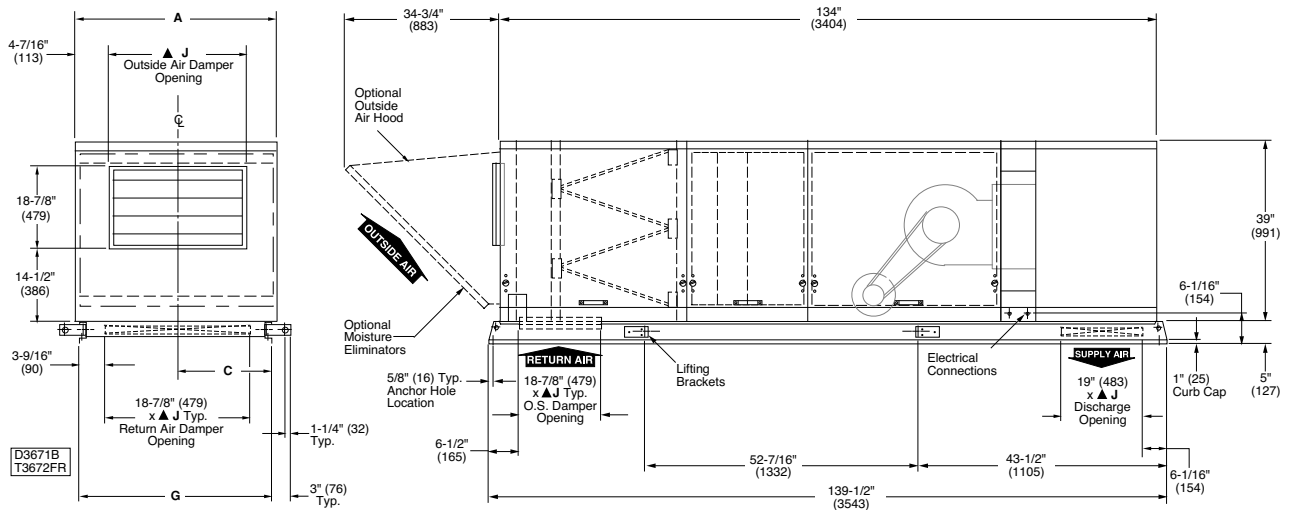

Rooftop Arrangement [RA] "W"

Capacities [CA] 20 or 40 Unit Sizes (Right hand service access shown)

Evaporative Cooling Unit

Unit Type [UT] (EV)*

Evaporative Cooling is the simplest and most-cost effective cooling method without the use of mechanical refrigeration. Sterling Evaporative Cooling systems meet a wide range of commercial, industrial, and institutional heating and ventilating requirements. The Evaporative Cooler saves up to 80% on utility charges, requires little maintenance, and replaces exhausted, stale, indoor air with cool, clean, filtered outdoor air.

*The quiet, dependable Evaporative Cooler may be purchased as an individual unit (unit type "EV") in four sizes from 800 CFM to 8500 CFM (0.4 - 4.0 m³/s), Capacities CA 10 to 40. Or, it can be combined with Sterling Rooftop Packaged Units (unit type "RT", "PV", Capacities CA 10 to 80), or Make-up Air Handlers (Capacities CA 10 to 80, see catalog GIAC for "MU/ME" Make-up Air Units). Evaporative Coolers are also combined in Air Handler Units (Capacities 20 or 40). In any combination, the Evaporative Cooler will replace the need for a 100% Outside Air Inlet Hood. If an Evaporative Cooler is to be installed upstream of our duct furnace section(s), a 409 stainless steel heat exchanger is recommended.

STANDARD FEATURES

- **High Cooling Efficiency** - Up to 88% saturation efficiency with standard 8 in. depth of CELdek® media, and up to 92% saturation efficiency with optional 12 in. depth media; a 2 in. distribution pad is included to disperse water evenly. CELdek® media is impregnated with insoluble anti-rot salts and rigidifying saturants. The unique design of the CELdek® pads optimizes air and water mixing for maximum cooling.
- **Optional 8 in. or 12 in. GLASdek® media** is also available.

- **Recirculating Pump** - Factory wired, sealed design, durable, thermally protected motor. Permanently lubricated bearings. Standard 115 Volt, 50/60 cycle. Optional 230V motor. Protective basket screen. U.L. recognized.
- **Heavy-Duty Stainless Steel Water Tank** - Stainless steel sump tank and water distributor designed to resist rust, corrosion, and scaling.
- **Ball Valve** - Single-entry ball valve regulates water flow using a 1/4 turn handle.
- **Bleed-Off** - Prevents excessive concentration of minerals in sump water.
- **Float Valve** - Brass float valve and rod with plastic float. Maintains proper water level in sump for most efficient operation. Factory installed in cabinet.
- **Drain and Overflow** - Drain is capped. Overflow controlled by float level allowing slight continued overflow. Optional automatic fill and drain kit is available for field installation.
- **Water Distribution** - Copper water distributor tube for corrosion-free operation and low maintenance.
- **Intake Filters** - Removable intake filters of easy-to-clean 1" aluminum mesh to remove insects, dust, and dirt from airflow.
- **Skid Rails** - With lifting and anchor holes. Optional platform curb assembly available, shipped separately (see Roof Curb Section)
- **Available** in 10 through 80 MBH capacities for 800 CFM to 8500 CFM (0.4 m³/s to 4.0 m³/s), and utilizes only 4 different cabinet widths.



Evaporative Cooler Module

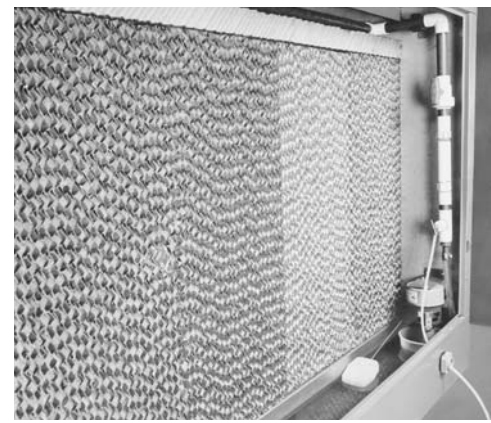

Internal View Evaporative Cooler

Evaporative Cooling Unit

Performance

Evaporative Cooling is most commonly used in areas where the relative humidity is low and the dry bulb temperatures are high. However, cooling through evaporation can be used in most areas.

Evaporative cooling is best utilized whenever the wet bulb depression (difference between dry and wet bulb temperature) is a minimum of 15 degrees.

The efficiency of the Sterling Evaporative Cooler is determined by a variety of factors: geographical location, application, air change requirements, sufficient water supply, air flow, and maintenance. In most instances, efficiency is expected to be between 77% and 88%. Heat gains in the distribution system will affect the final output temperature.

Use the psychometrics chart (shown in Diagram #1) or actual humidity temperature readings to estimate the leaving dry bulb temperature at the outlet of the Evaporative Cooler.

Example:

1. Entering Dry Bulb: 95°F
2. Entering Wet Bulb: 75°F
3. Wet Bulb Depression (95°F - 75°F) = 20°F
4. Effective Wet Bulb Depression (20°F X .85) = 17°F
5. Leaving Dry Bulb Temperature (95°F - 17°F) = 78°F
6. Leaving Wet Bulb = Entering Wet Bulb = 75°F

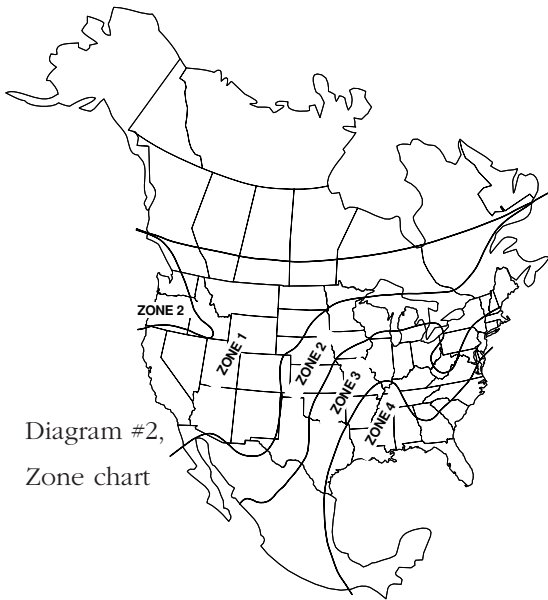

Diagram #2,
Zone chart

Selection Method

The easiest method for selecting an evaporative cooler, is to first determine the required number of air changes per minute.

- A. Using Diagram #2, choose the geographical zone in which the unit is to be installed.
- B. Determine the internal load within the structure:

Normal Load: Structures with normal people loads, and without high internal heat gains.

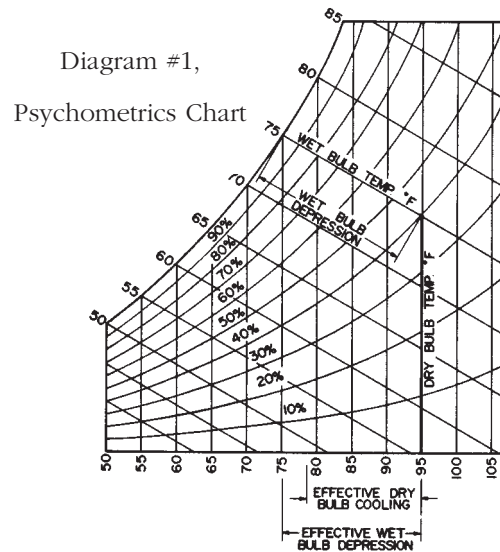

Diagram #1,

Psychometrics Chart

High Load: Structures with high equipment loads (i.e. factories, laundromats, beauty salons, restaurant kitchens, etc.), and structures with high occupancy (nightclubs, arenas, etc.)

- C. Determine whether the structure has normal or high heat gains: **Normal Gain:** Structures that have insulated roofs, or are in shaded areas. Structures that have two or more stories, or facing directions with no sun. **High Gain:** Structures that have uninsulated roofs, unshaded areas, or rooms that are exposed to sun.
- D. Using table below, determine the required air changes per minute based on zone selection and the type of heat load.
- E. Finally, determine the air quantity for the space chosen, by calculating the volume (L x W x H). Multiply this volume by the air changes per minute.

Example:

1. Structure Dimensions: 25 L x 24 W x 10 h = 6000 Ft³
2. Exterior Load Type: Normal
3. Interior Load Type: Normal
4. Location: Dallas, Texas- Zone 3
5. Air Changes Per Minute: 3/4
6. Evaporative Cooler Requirements:
6000 Ft³ x 3/4 Air Change / minute = 4500 CFM Required

See Evaporative Cooler Performance Chart for unit size that would best apply.

(Air Changes Per Minute) Table				
Type Heat Load	Zone			
	1	2	3	4
High Load/High Gain	3/4	1	1-1/3	2
High Load/Normal Gain	1/2	3/4	1	1-1/3
Normal Load/High Gain	1/2	3/4	1	1-1/3
Normal Load/Normal Gain	1/2	1/2	3/4	1

Evaporative Cooling Unit

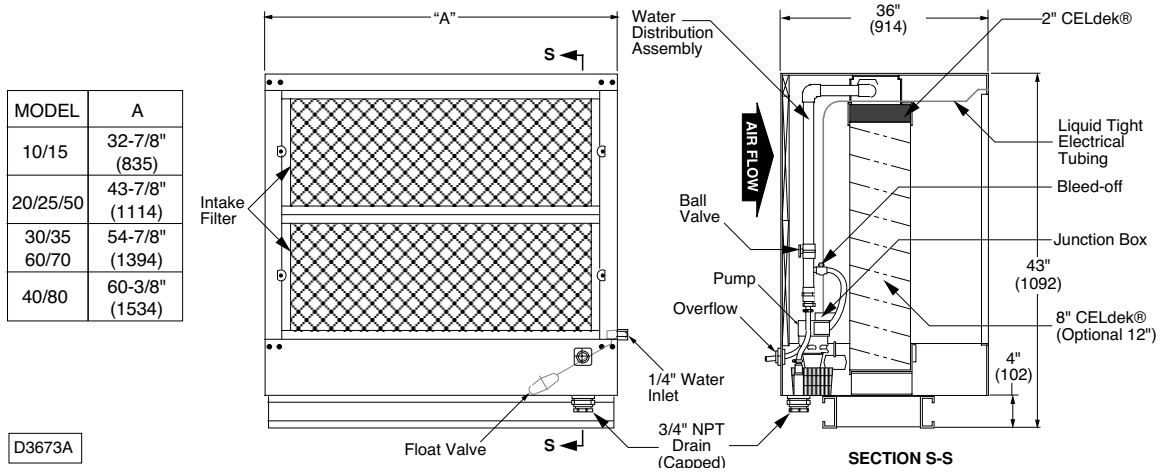

MODEL	A
10/15	32-7/8" (835)
20/25/50	43-7/8" (1114)
30/35 60/70	54-7/8" (1394)
40/80	60-3/8" (1534)

D3673A

Refer to pages 29 and 30 for additional unit dimensions for rooftop arrangements D or E.

Performance and Dimensional Data

Capacity 10-80	CFM		8" Saturation Efficiency Range		12" Saturation Efficiency Range		8" or 12" Media Face Area		Pressure Drop in. W.C.		"A" Unit Width	Shipping Wt.*	Operating Wt.*
	(cu. m/s) MIN.	(cu. m/s) MAX.	MIN.	MAX.	MIN.	MAX.	Ft. ² (m ²)	Size In. (mm)	(KPa) MIN.	(KPa) MAX.	in. (mm)	lb. (kg)	lb. (kg)
10,15	800 (0.378)	4,500 (2.124)	78	88	89	92	7.01 (0.65)	31 X 32-9/16 (787) (827)	0.03 (0.01)	0.23 (0.06)	32 3/4 (832)	137 (62)	301 (137)
20,25,50	1,600 (0.755)	5,500 (2.596)	77	88	88	92	9.38 (0.87)	31 X 43-9/16 (787) (1106)	0.03 (0.01)	0.20 (0.05)	43 3/4 (1111)	166 (75)	386 (175)
30,35,60,70	2,400 (1.133)	8,500 (4.012)	77	86	88	92	11.75 (1.09)	31 X 54-9/16 (787) (1386)	0.05 (0.01)	0.30 (0.07)	54 3/4 (1391)	192 (87)	468 (212)
40,80	3,200 (1.510)	8,500 (4.012)	77	86	87	92	12.92 (1.20)	31 X 60 (787) (1524)	0.07 (0.02)	0.28 (0.07)	60 1/4 (1530)	206 (93)	509 (231)

* These weights are for the Evaporative Cooler Module only; see Table 14 for Arrangement C and E total unit weights.

CELdek® EVAPORATIVE MEDIA

The Sterling Evaporative Cooler utilizes high efficiency CELdek® media. CELdek® is made from a special cellulose paper, impregnated with insoluble anti-rot salts and rigidifying saturants. The cross fluted design of the pads induces highly-turbulent mixing of air and water for optimum heat and moisture transfer. Sterling Evaporative Coolers utilize 8 in. CELdek® as standard equipment. Optional 12 in. CELdek®, 8 in. and 12 in. GLASdek® are also available. A 2 in. distribution pad is used to disperse water evenly over the media.

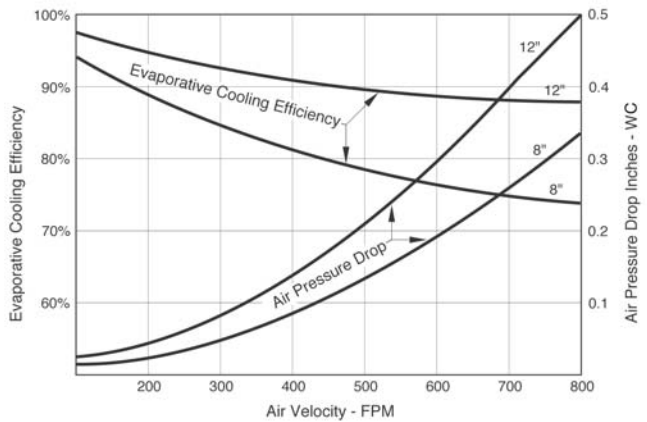

EVAPORATIVE COOLER EFFICIENCY/A.P.D. CHART



Standard Roof Curb Kits

(RC001 - RC013 and RC015)

Sterling roof curbs are available in various types depending upon your application needs. Curbs are available in single, dual or triple furnace arrangements and air handler only units. All curb kits (see table) are knocked down for field assembly and are shipped separately. Curbs are typically available on a short lead time basis allowing the installer to set the curb in place prior to receiving the rooftop unit.

Standard curbs are 12 in. high. Factoring in the 4 in. unit base rail, overall height to the bottom of the rooftop unit is actually 16 in. All standard curbs are fully factory insulated.

Standard Rooftop Curb Kits RC002, RC004, RC008 and RC012 include an evaporative cooler platform. Kit RC015 (evaporative cooler platform only) is for use with unit type EV.

Uninsulated Roof Curb Kits

(URC001 - URC013)

Sterling uninsulated roof curb kits are identical to the standard kits, with the exception of the insulation.

Roof Curb Ductwork Adapter Kits

(RC016 - RC018)

Allows field installed supply and/or return duct work to be terminated at the roofcurb instead of at the unit.

Can be used with any Sterling insulated or uninsulated curb.

Vibration Isolation Curbs

(VC001 - VC013)

Vibration isolation curbs incorporate adjustable spring isolators into the standard roof curb. The isolators are specifically engineered and positioned to accommodate the rooftop unit.

Vibration isolation curbs are utilized in installations where slight rooftop vibration or noise is a concern.

A minimum of 90 percent isolation efficiency is assured. Isolation curbs are fully factory assembled or knocked down into a limited number of sub assemblies. Not available on evaporative cooler rooftop arrangements D,E,P,R.

Adaptor Curbs

Adaptor curbs are designed for retrofit installations. With the use of an adaptor curb it is not necessary to remove the existing curb, thus eliminating extensive rooftop work, time and associated construction costs.

Provide us with the existing unit model number and curb dimensions or complete the Adaptor curb specification sheet (available from your local representative) and a custom adaptor curb will be supplied to accommodate the new rooftop unit.

Dimensional Data – Roof Curb Kits

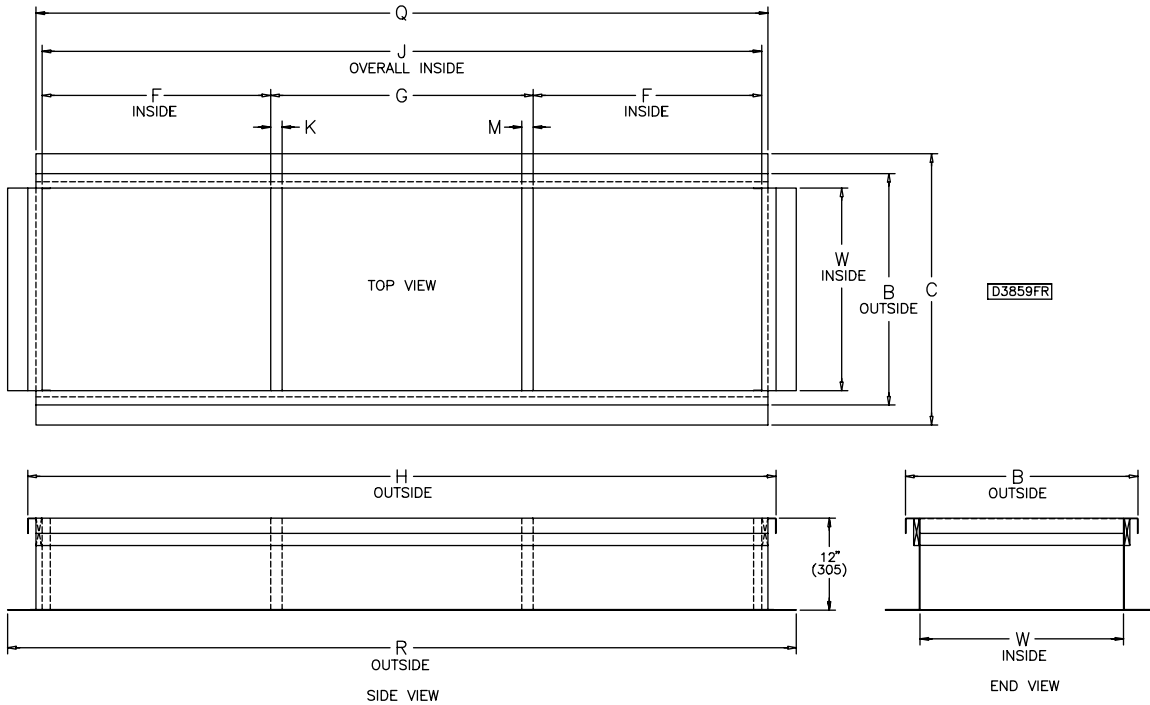

CURB KIT NO.	ROOFTOP ARRANGEMENT (RA)	CAPACITY (CA)	F	G	H	J	Q	R	K	M
RC001-*	B & D	10/40								
RC002-*	B & D	10/40	29-5/8 (752)	8-1/8 (206)	71-1/8 (1,806)	67-3/8 (1,711)	69" (1,753)	76-3/8 (1,940)		
RC003-*	B & D	50/80								
RC004-*	C & E	10/40								
	G	50/80								
RC005-*	J	20/40	37-1/8 (943)	55-1/4 (1,403)	133-1/4 (3,385)	129-1/2 (3,289)	131-1/8 (3,331)	138-1/2 (3,518)		
	K	10/40							1-1/2 (38)	1-1/2 (38)
RC006-*	G	20/40	37-3/16 (944)	29-3/16 (741)	107-5/16 (2,726)	103-9/16 (2,631)	105-3/16 (2,672)	112-9/16 (2,859)		
RC007-*	C & E	50/80	30-1/8 (765)	59" (1,499)	123" (3,124)	119-1/4 (3,029)	120-7/8 (3,070)	128-1/4 (3,257)		
RC008-*	G	12								
	J & K	50/80	37-5/16 (948)	80-15/16 (2,056)	159-5/16 (4,046)	155-9/16 (3,951)	157-1/4 (3,994)	164-1/2 (4,178)		
	L	10/40								
RC009-*	J	12								
	L	50/80	36-15/16 (936)	107-11/16 (2,735)	185-5/16 (4,707)	181-9/16 (4,612)	183-1/4 (4,655)	190-1/2 (4,839)		
RC010-*	L	50/80								

ROOFTOP ARRANGEMENT (RA)	CURB KIT NO.	CAPACITY (CA)	W	B	C
ALL	* -1	10/15	26-7/16 (671)	30-3/16 (767)	35-7/16 (900)
	* -2	20/25/50	37-7/16 (951)	41-3/16 (1,046)	46-7/16 (1,179)
	* -3	30/35/60/70	48-7/16 (1,230)	52-3/16 (1,325)	57-7/16 (1,459)
	* -4	40/80/12	53-15/16 (1,370)	57-11/16 (1,465)	62-15/16 (1,599)

*Curb Kit Suffix Legend	
Capacity	Suffix
10, 15	-1
20, 25, 50	-2
30, 35, 60, 70	-3
40, 80, 12	-4

CAPACITY (CA)	CURB KIT NO.	ROOFTOP ARRANGEMENT (RA)	F	G	H	J	Q	R	K	M
20 OR 40	RC011-*	M & P	N/A	N/A	45-1/4 (1,149)	41-1/2 (1,054)	43-1/8 (1,095)	50-1/2 (1,283)	N/A	N/A
	RC001-*	N & R	29-5/8 (752)	8-1/8 (206)	71-1/8 (1,806)	67-3/8 (1,711)	69" (1,753)	76-3/8 (1,940)	1-1/2 (38)	1-1/2 (38)
	RC002-*	N & R	29-5/8 (752)	8-1/8 (206)	71-1/8 (1,806)	67-3/8 (1,711)	69" (1,753)	76-3/8 (1,940)	1-1/2 (38)	1-1/2 (38)
	RC013-*	S	38-1/8 (968)	N/A	81-7/16 (2,069)	77-11/16 (1,973)	79-5/16 (2,015)	86-11/16 (2,202)	1-1/2 (38)	N/A
	RC006-*	T & U	37-3/16 (944)	29-3/16 (741)	107-5/16 (2,726)	103-9/16 (2,630)	105-3/16 (2,672)	112-9/16 (2,859)	1-1/2 (38)	1-1/2 (38)
	RC005-*	W	37-1/8 (943)	55-1/4 (1,403)	133-1/4 (3,385)	129-1/2 (3,289)	131-1/8 (3,331)	138-1/2 (3,518)		

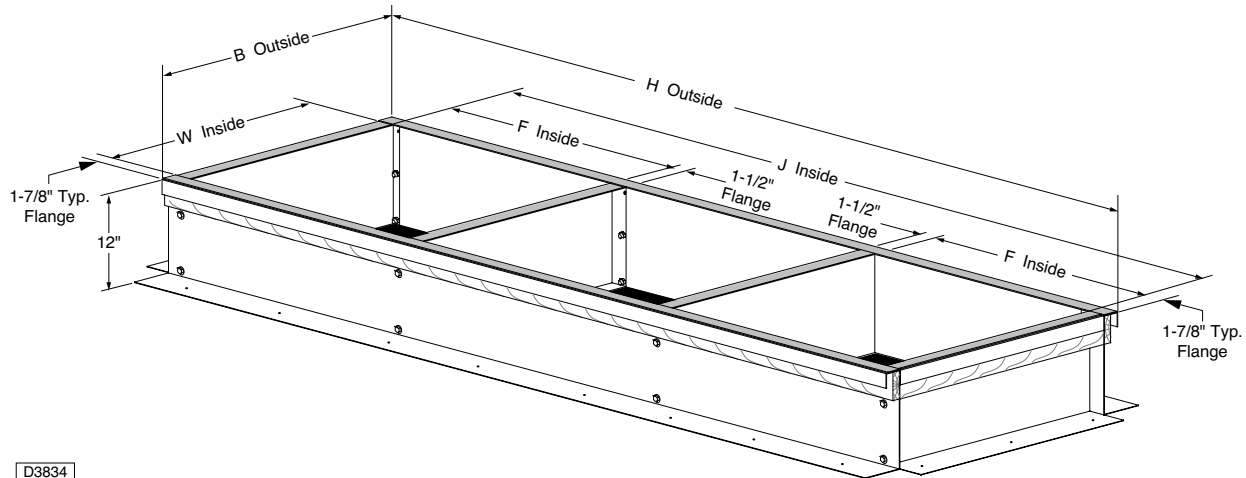

D3834

See page 62 for "A" Dimensions.



Roof Curb Specifications

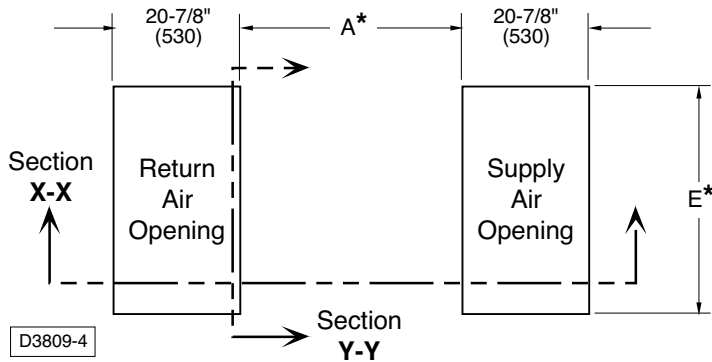

Unit Type [UT] "RT, PV or AH"	
Capacity [CA]	Dimension E *
10/15	26" (660)
20/25/50	37" (940)
30/35/60/70	48" (1219)
40/80/12	53-1/2" (1359)

* All Dimensions Shown Have Been Calculated To Include A One (1) Inch Clearance Around Return And Supply Ducts.

Unit Type [UT] "RT or PV"							
** Rooftop Arrangement [RA]	FURNACE	Capacity [CA]	Unit Specifications (References)			* Dimension A	
			Blower		Coil		Supply Plenum
			St'd.	High CFM			
C, E	SINGLE	10 - 40	✓			✓	50-7/8" (1292)
J		20 - 40		✓		✓	87-1/16" (2211)
L		10 - 40		✓	✓	✓	113" (2871)
C, E	DUAL	50 - 80	✓			✓	76-7/8" (1952)
J		50 - 80		✓		✓	113" (2871)
L		50 - 80		✓	✓	✓	139" (3531)
J		12		✓		✓	139" (3531)

Unit Type [UT] "AH"						
** [RA]	[CA]	Blower		Coil	Supply	* A
		St'd.	Hi			
N, R	20 or 40	✓			✓	24-7/8" (631)
T	20 or 40		✓		✓	61-1/16" (1551)
W	20 or 40		✓	✓	✓	87-1/16" (2211)

** Rooftop Arrangements [RA] B, D, G, K, M, P, S & U Are Without a Supply Plenum. Use The Same Return Air Dimensions For These Units Rooftop Openings. Refer To Unit Submittals For More Detail.

D3809-1

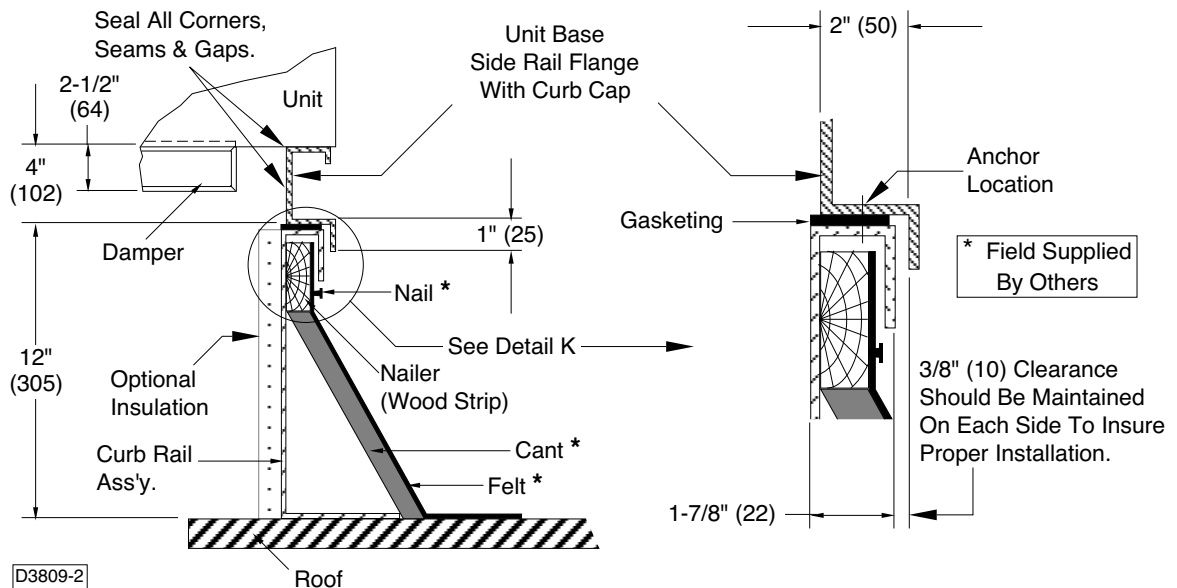

Section Curb Side Rail

Detail K

Roof Curb Kit Assembly

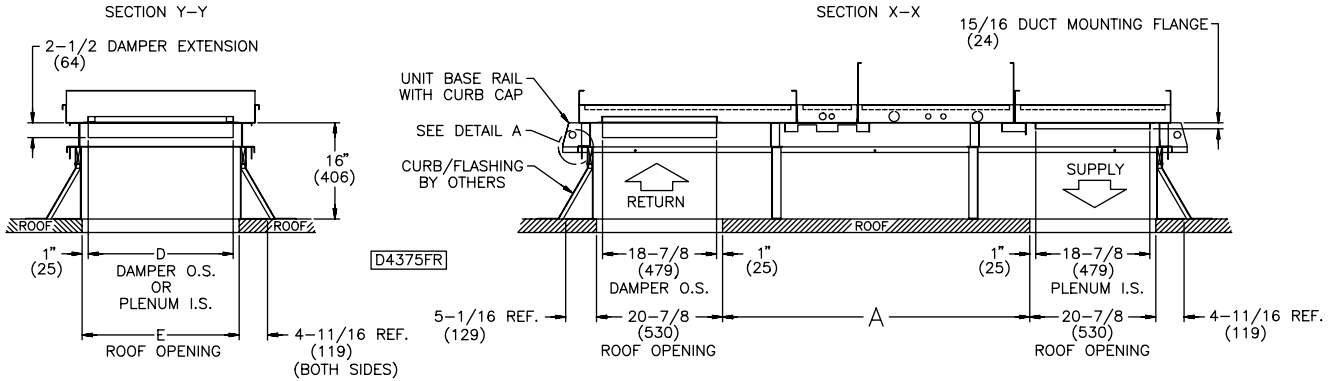

MODEL	D	E
10,15	24" (610)	26" (660)
20,25,50	35" (889)	37" (940)
30,35,60,70	46" (1,168)	48" (1,219)
40,80,12	51-1/2" (1,308)	53-1/2" (1,359)

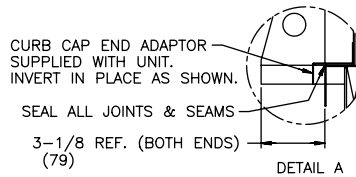

Refer to page 62 for "A" dimensions and references to sections X-X and Y-Y.

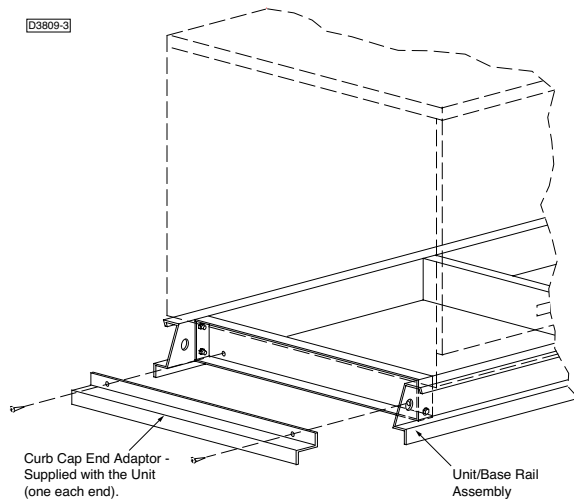
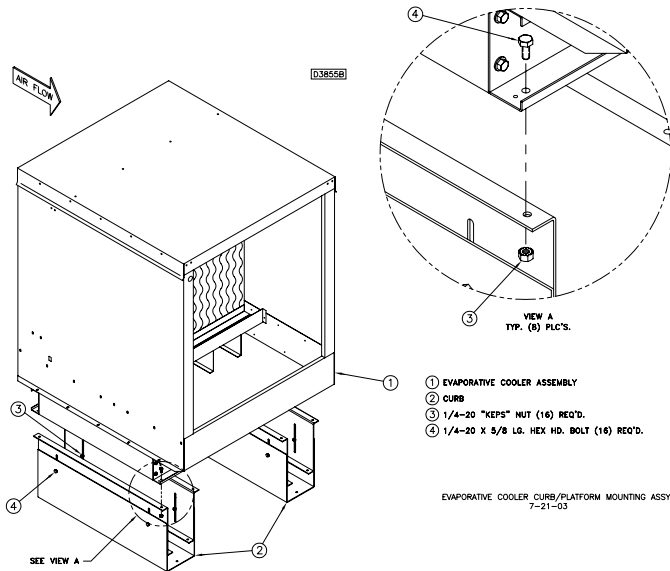

* For Field Installations: These Crossbrace/Curb Adaptors (2 adaptors ship with each rooftop arrangement) must be repositioned in the field when the unit is mounted on a curb or a platform (one for each end). Simply remove the screws, turn the piece over (end for end) and secure in place using the holes/hardware provided. **All joints and seams must be sealed completely in the field to prevent leaks.**

Engineered Products Specification Guide

A. General

A.1 Standards & Certifications

All units must be:

- A.1.a** A.G.A. and C.G.A. Certified duct furnace(s) which conform to the latest ANSI standards for efficiency and safe performance.
- A.1.b** ETL or UL Certified for electrical safety in compliance with UL 1995 safety standard for heating, ventilating and cooling equipment (see previous information).
- A.1.c** Compliant with FM (Factory Mutual) requirements.
- A.1.d** (opt.) Compliant with IRI (Industrial Risk Insurers) requirements. (Include 100% shut-off type (lockout) ignition system, and mechanically exhaust (power vent) products of combustion).

A.2 Fuel Types

Rooftop unit will be suitable for operation with:

- (a) Natural Gas.
- (b) LP (propane) Gas.

A.3 Mechanical Arrangement

Rooftop unit will consist of a:

- A.3.a** Furnace section consisting of a:
 - (a) Single Furnace (100-400 MBh units)
 - (b) Dual Furnace (500-800 MBh units)
 - (c) Triple Furnace (1200 MBh units)The firing rate of each furnace will not exceed 400 MBh and will contain its own Heat Exchanger, Flue Collector, Venting, Burners, Safety and Ignition Controls.
- A.3.b** Blower Section containing supply blower(s) and blower motor. The blower motor will be interlocked electrically and disengage the blower motor and control circuit upon opening the service panel.
- A.3.c** Electrical Cabinet that is isolated from the air stream with a non removable access panel interior to the outer service panel. Provision for component mounting, wire routing and high voltage isolation.
- A.3.d** Rooftop unit will be provided with:
 - (a) Outside air and Return air opposed blade dampers.
 - (b) Outside air opposed blade dampers.
 - (c) Return air opposed blade dampers.
 - (d) No dampers.
- A.3.e** Filter Section will accommodate 1 or 2 inch washable, pleated high-efficiency filters, or 2 inch throwaway; and be of a V-bank design for minimal pressure drop.
- A.3.f** Supply plenum will be provided with down flow discharge.
- A.3.g** Return air will enter through a bottom return air opening.
- A.3.h** A Cooling Coil Section constructed of galvanized steel will be provided with the unit.
- A.3.h.1** Direct Expansion (DX) Evaporator Coil certified by ARI will be provided.
- A.3.h.2** Chilled Water Coil certified by ARI will be provided.
- A.3.i** An Evaporative Cooler with 8 inch media will be provided. The Evaporative cooler will be of a self cleaning design with a stainless steel water tank, regulated water flow and overflow protection. The cooler will have a cabinet assembly of heavy-gauge aluminized steel with weatherproof finish, a U.L. recognized thermally protected sealed re-circulating pump motor, two inch distribution pad, and corrosion resistant PVC water distribution tubes.
 - A.3.i.1** (opt.) An automatic Fill and Drain Kit will be provided for field installation.
 - A.3.i.2** (opt.) A platform Mounting Curb will be provided.
 - A.3.i.3** (opt.) High-Efficiency 12 inch deep media will be provided.

- A.3.j** (opt.) The unit will mount on a factory supplied roof curb, that is shipped un-assembled with hardware package and gasket attached. Curb and rail will total 16 inches high and supplied with a cross-member which allows isolation of return and supply air streams. Curb will be
 - (a) Insulated.
 - (b) (opt.) Spring Isolated.
 - (c) (opt.) Adaptor Type.

A.4 Electrical Systems

- A.4.a** All electrical components and fixtures will carry UL or ETL and/or CSA listing, certification and/or recognition.
- A.4.b** All wire will be rated to meet or exceed electrical requirements for voltage, ampacity, dielectric strength of sheathing and temperature rating per location.
- A.4.c** Standard control relays will be socket mounted with terminal block connections.
- A.4.d** All high voltage wiring will be enclosed in flexible metallic sheathed BX cable and include an identifying marker corresponding to the wiring diagram.
- A.4.e** All control wiring will terminate at terminal strips (single point connection) and include an identifying marker corresponding to the wiring diagram.

A.5 Mounting

Rooftop unit will be mounted on metal rails with down-rolled outer edges with lifting and anchor holes and be suitable for slab or curb mounting.

A.6 Standard Safety Provisions

- A.6.a** Rooftop unit will be provided with a low voltage circuit breaker rated for 150% of the units normal 24 volt operating load.
- A.6.b** An access interlock switch will be installed in the blower compartment and will disengage the blower upon removing the service panel. An override or cheat switch will be incorporated into the interlock switch for serviceability.
- A.6.c** Each duct furnace will be provided with a primary limit switch 24V high temperature limit switch and a (redundant) combination gas valve.
- A.6.d** Rooftop units will contain a Reverse Air Flow Interlock Switch. The normally closed switch when activated will cause gas valves to close.
- A.6.e** A Drafter Prove switch will be installed in all power vented units and disengage gas flow if for any reason the drafter has failed to operate.
- A.6.f** Warning labels will be visible in accessible areas of the rooftop where unsafe conditions could occur.

A.7 Optional Safety Provisions (opt.)

- A.7.a** A high pressure interlock switch and shutoff valve will be provided for each furnace section.
- A.7.b** A low pressure interlock switch and shutoff valve will be provided for each furnace section.
- A.7.c** A flame fault indicator relay will be provided for each duct furnace with provision for remote indicator connection.
- A.7.d** Rooftop unit will be provided with a Firestat located in the return air stream. If the return air temperature reaches the set point (typically 130°F) the unit will close all gas valves, return dampers to their normal position and shut down the blower.
- A.7.e** Rooftop unit will be provided with a Firestat located in the supply air stream. If the supply air temperature reaches the set point (typically 150°F) the unit will close all gas valves, return dampers to their normal position and shut down the blower.
- A.7.f** Rooftop unit will be provided with a Time Delay Freezestat with the sensing bulb located in the discharge air stream. Wired as an interlock to prevent cold air discharge.

Engineered Products Specification Guide

- A.7.g** Rooftop unit will be provided with an manually reset high limit switch wired in series to the lead furnace high limit. If the set point is reached the gas valve will close and the blower will continue to run until the sensed temperature is below the set point.
- A.7.h** A Clogged Filter Pressure Switch with adjustable operating range and normally open switch will be installed to sense increased suction pressure by the blower due to filter obstruction. Provision for remote indication will be provided by terminal block connection points.
- A.7.i** Rooftop units shall be provided with an Ambient Lockout Thermostat and wired as an interlock to prevent duct furnaces(s) from firing during times of mild ambient temperatures.

B. Burners

- B.1** Burners will be die formed with stamped porting and stainless steel port protectors to prevent scale or foreign matter from obstructing the burner ports.
Burner construction will consist of:
 - (std.) Corrosion Resistant Aluminized Steel.
 - (opt.) Type 409 Stainless Steel.
- B.2** Burners must be individually removable for ease of cleaning and servicing. The entire burner assembly must be easily removable with a slide-out drawer design. The pilot must be accessible through a pilot access plate without removing the burner assembly.
- B.3** (opt.) Burners will be fitted with orifices suitable for higher elevations.(over 2000 feet)

C. Heat Exchanger

- The Heat Exchanger construction will consist of:
 - (std.) 20 gauge aluminized steel tubes, and 18 gauge aluminized steel headers.
 - (opt.) 20 gauge 409 stainless steel tubes, and 20 gauge headers.
 - (opt.) 20 gauge 321 stainless steel tubes, and 20 gauge headers.

D. Venting System

- D.1** The Flue Collector construction will consist of:
 - (std.) Corrosion Resistant Aluminized Steel.
 - (opt.) Type 409 Stainless Steel.
- D.2** Rooftop will be provided with:
Natural Venting. A square flue vent cap designed for gravity venting will be provided. Outside air for combustion will enter at the base of vent cap through a protective grille. Products of combustion will be discharged through the upper section of the flue vent cap. (opt.) An A.G.A./C.G.A. approved extended vent cap will be provided.

Power Venting. A power vent fan for venting will be provided. Outside air for combustion and products of combustion will have individual air inlet and discharge grilles located in the upper section of the furnace service panel. A drafter prove switch will be installed and its normally open contacts wired in series with the main gas valve.

E. Drip Pan

- The Positive Drain Drip Pan construction will consist of:
 - (opt.) Type 409 stainless steel.

F. Cabinetry

- F.1** Cabinetry will be die-formed, 18 gauge Galvanized steel and finished in air-dry enamel.
- F.2** Service and access panels shall be provided through easily removable side access panels with captive fasteners.
- F.3** Burner sections, Supply Plenums, and coil section when provided will be insulated with fire resistant, environmentally safe, odorless, one inch fiber material.
 - (std.) Matte Faced.
 - (opt.) Foil Face Insulation.

G. Dampers

Dampers will be of the opposed blade type, constructed of galvanized steel with neoprene nylon bushings, blades to be mechanically interlocked.
(opt.) Leak Proof Damper (outside air only) will be of the opposed blade type, constructed of galvanized steel with neoprene nylon bushings and vinyl blade edge seals, blades to be mechanically interlocked.

H. Filter Rack

Filter Rack will be constructed of galvanized steel with access through the side service panel.

I. Intake Hood

Intake hood will be constructed of galvanized steel and include a: (std.) bird screen. (opt.) moisture eliminator.

J. Supply Blower

Supply Blower will be belt driven, forward curved, centrifugal type blower assembly, statically and dynamically balanced with double inlet. The blower wheel will be fixed on a shaft, supported with super quiet rubber cartridges for vibration isolation, and ball bearing.

K. Blower Motor

K.1 Type

K.1.a Motor will be Single Speed, Ball Bearing Drive, Permanently Lubricated, EPACT Compliant, Standard NEMA Frame Size and Service Factor, with Resilient Base and Class B Windings:

- (std.) Open Drip Proof
- (opt.) Totally Enclosed
- (opt.) Premium Efficiency
- (opt.) Two Speed

K.1.b

- Motor will operate at:
- (a) 115V/1/60
 - (b) 230V/1/60
 - (c) 208V/3/60
 - (d) 230V/3/60
 - (e) 460V/3/60
 - (f) 575V/3/60

K.1.c Motor will have a horse power rating of: (1/2 - 15 HP)

K.2 Wiring

Motor wiring will be enclosed in flexible metallic sheathed BX conduit.

K.3 Control

- Motor will be activated through a:
- (a) Relay. (std. 1/2 - 1 HP)
 - (b) Contactor. (std. 1-1/2 - 5 HP)
 - (c) Magnetic starter. (std. 7-1/2 - 15 HP)

K.4 Motor Protection

- shall be provided with:
- (a) Internal thermal protection. (Relay/Contactor actuated)
 - (b) IEC overload protection. (Magnetic starter)

L. Gas and Ignition Systems

L.1 Ignition System

A Solid State ignition control system which ignites the pilot by spark during each cycle of operation will be provided. When pilot flame is proven, main burner valve will open to allow gas flow to burners. Pilot and burners must be extinguished during the off cycle.
(opt.) Ignition system will be 100% lockout type.

L.2 Valve

Rooftop units will be provided with a gas valve suitable for NEC Class 2 use, for a maximum inlet of 0.5-psi (14 inch W.C.) on natural gas. The 24 volt combination automatic gas valves must include a main operating valve, pilot safety valve, pressure regulator, manual main and pilot shutoff valve and adjustable pilot valve.
(opt.) Unit will be provided with a high pressure gas regulator valve.

Engineered Products Specification Guide

M. Gas Controls

- (a std.) **Single Stage** unit will be provided with one stage of heat. Ignition is the full rate of the furnace(s) rated input.
- (b) **Two Stage** unit will be provided with two stages of heat. Ignition will be at low fire (one half) of the rated input.
- (c) **Hydraulic Modulating Gas.** Unit will be provided with modulated heat output. Ignition will be at low fire (one half of the full input rate), and a discharge temperature sensing bulb located in the air stream will modulate the gas input from 40 to 100 percent rated input. Unit will be provided with an automatic valve in series with the hydraulic valve to cycle the unit.
- (d) **Hydraulic Modulating Gas** with Bypass Manifold. Unit will be provided with modulated heat output. Ignition will be at low fire (one half of the full input rate), and a discharge temperature sensing bulb located in the air stream will modulate the gas input from 40 to 100 percent rated input. Unit will be provided with an automatic valve in series with the hydraulic valve to cycle the unit and an additional electric valve in parallel to bypass the hydraulic modulating valve, overriding the discharge temperature sensing bulb, allowing full fire. Unit will be provided with a separate room thermostat to control the electric valve.
- (e) **Electronic Modulating Gas** unit will be provided with modulated heat output. An automatic valve in series with the modulating valve will be provided to cycle the unit. Ignition will be at full fire (100 percent rated input) and modulate the gas input from 100 to 40 percent rated input. The Modulating Gas valve will operate in response to:
 - (1) Room Thermostat
 - (2) Duct Thermostat with remote temperature adjustment.
 - (3) Duct Thermostat with remote temperature adjustment and an override room thermostat which will increase the rate of modulated input to the unit in proportion to the difference in room temperature.
- (f) **Electronic Modulating Gas DDC** unit will be provided with modulated heat output. An automatic valve in series with the modulating valve will be provided to cycle the unit. Ignition will be at full fire (100 percent rated input) and modulate the gas input from 100 to 40 percent of the rated input. The modulating gas valve will operate in response to a 4-20 mA input from an external DDC control.
- (g) **Electronic Modulating Gas DDC** unit will be provided with modulated heat output. An automatic valve in series with the modulating valve will be provided to cycle the unit. Ignition will be at full fire (100 percent rated input) and modulate the gas input from 100 to 40 percent of the rated input. The modulating gas valve will operate in response to a 0-10 VDC input from an external DDC control.
- (h) **Three Stage.** (Triple Furnace Units) Unit will be provided with one stage of heat per furnace. Ignition will be determined by an Electronic Step Control. Each stage of fire will have no less than a 4 degree F temperature differential setting. The unit will fire at one third (33 percent) of the rooftop unit(s) rated input per stage. Furnace one will always fire first and disengage last.

- (i) **Four Stage** (Dual Furnace Units) Unit will be provided with two stages of heat per furnace. Ignition will be determined by an Electronic Step Control. Each stage of fire will have no less than a 4 degree F temperature differential setting. The unit will fire at one quarter (25 percent) of the rooftop unit(s) rated input per stage. Furnace one will always fire first and disengage last.
- (k) **Six Stage** (Triple Furnace Units) Unit will be provided with two stages of heat per furnace. Ignition will be determined by an Electronic Step Control. Each stage of fire will have no less than a 4 degree F temperature differential setting. The unit will fire at one sixth (16.5 percent) of the rooftop unit(s) rated input per stage. Furnace one will always fire first and disengage last.
- (l) **One Stage with Electronic Modulation DDC** (Dual Furnace Units) Unit will be provided with modulated heat output on furnace one and one stage of heat on furnace two. Ignition will be determined by an Electronic Step Control. Each stage of fire will have no less than a 4 degree F temperature differential setting. The rooftop unit will fire at approximately one half (50 percent) of the rooftop unit(s) rated input and modulate from 50 - 25 percent fire on furnace one. Additional stages of fire will engage as the 50 percent of fire has been maintained for the duration of a delay setting at the electronic step control with respect to each set point. Furnace one will always fire first and disengage last.
- (m) **Two Stage with Electronic Modulation DDC** (Triple Furnace Units) Unit will be provided with modulated heat output on furnace one and one stage of heat on furnace two and three. Ignition will be determined by an Electronic Step Control. Each stage of fire will have no less than a 4 degree F temperature differential setting. The rooftop unit will fire at a approximately one third (33 percent) of the rooftop unit(s) rated input and modulate from 33 - 16.5 percent fire on furnace one. Additional stages of fire will engage as the 33 percent of fire has been maintained for the duration of a delay setting at the electronic step control with respect to each set point. Furnace one will always fire first and disengage last.

N. Damper Motor

N.1 Type

- N.1.a** Damper motor will be:
- (a) Two position with spring return.
 - (b) Modulating.
 - (c) Modulating with spring return.

N.1.b Motor will operate at 24 volts.

N.2 Wiring

Motor and control wiring will be harnessed with terminal block connections. Wire will have a temperature rating of at least 105 deg. C outside of the duct furnace. The wire contained within the duct furnace(s) will have a temperature rating of at least 200 deg C.

O. Damper Control

- (a) Two position spring return motor with outside air damper will be provided. The motor will power the outside air damper full open when the unit is on and full closed when the unit is off.
- (b) Two position spring return motor with return air damper will be provided. The motor will power the return air damper full open when the unit is on and full closed when the unit is off.

Engineered Products Specification Guide

- (c) Two position spring return motor with interlocked outside and return air dampers will be provided. The motor will power either the outside air damper full open and the return air damper full closed or the outside air damper full closed and the return air damper full open in response to an outside air temperature sensor. When the unit is off the motor will drive the outside air dampers full closed and the return air dampers full open.
- (d) Modulating motor with interlocked outside and return air dampers will be provided. The motor will modulate the position of the outside and return air dampers in response to a thermostatic controller located in the mixed air stream. Units will also be provided with a minimum position potentiometer for minimum outside air damper position.
- (e) Modulating motor with spring return and interlocked outside and return air dampers will be provided. The motor will modulate the position of the outside and return air dampers in response to a thermostatic controller located in the mixed air stream. Units will also be provided with a minimum position potentiometer for minimum outside air damper position. When the unit is off the motor will drive the outside air dampers full closed and the return air dampers full open.
- (g) Modulating motor with interlocked outside and return air dampers will be provided. The motor will modulate the position of the outside and return air dampers in response to a thermostatic controller located in the mixed air stream.
- (h) Modulating motor with spring return and interlocked outside and return air dampers will be provided. The motor will modulate the position of the outside and return air dampers in response to a thermostatic controller located in the mixed air stream. When the unit is off the motor will drive the outside air dampers full closed and the return air dampers full open.
- (j) Modulating motor with interlocked outside and return air dampers will be provided. The motor will position the outside and return air dampers in response to a manually set potentiometer.
- (k) Modulating motor with interlocked outside and return air dampers will be provided. The motor will position the outside and return air dampers in response to a manually set potentiometer. When the unit is off the motor will drive the outside air dampers full closed and the return air dampers full open.
- (l) Modulating motor with interlocked outside and return air dampers will be provided. The motor will modulate the position of the outside and return air dampers in response to a thermostatic controller and dry bulb located in the mixed air stream. Units will also be provided with a minimum position potentiometer for minimum outside air damper position.
- (m) Modulating motor with spring return and interlocked outside and return air dampers will be provided. The motor will modulate the position of the outside and return air dampers in response to a thermostatic controller and dry bulb located in the mixed air stream. Units will also be provided with a minimum position potentiometer for minimum outside air damper position. When the unit is off the motor will drive the outside air dampers full closed and the return air dampers full open.
- (n) Modulating motor with spring return and interlocked outside and return air dampers will be provided. The motor will modulate the position of the outside and return air dampers in response to an enthalpy controlled economizer. When the unit is off the motor will drive the outside air dampers full closed and the return air dampers full open.
- (p) Modulating motor with spring return and interlocked outside and return air dampers will be provided. The motor will modulate the position of the outside and return air dampers in response to a pressure sensor located in the building. When the unit is off the motor will drive the outside air dampers full closed and the return air dampers full open.
- (q) Modulating motor with spring return and interlocked outside and return air dampers will be provided. The motor will modulate the position of the outside and return air dampers in response to a carbon monoxide monitor located in the return air duct. When the unit is off the motor will drive the outside air dampers full closed and the return air dampers full open.
- (r) Modulating motor with spring return and interlocked outside and return air dampers will be provided. The motor will modulate the position of the outside and return air dampers in response to a Solid State mixed air sensor and S-350 proportional controller. When the unit is off the motor will drive the outside air dampers full closed and the return air dampers full open.
- (s) Modulating motor with spring return and interlocked outside and return air dampers will be provided. The motor will modulate the position of the outside and return air dampers in response to a 4-20 mA or 0-10 VDC analog signal supplied by an external DDC controller.
- (t) Modulating motor with spring return and interlocked outside and return air dampers will be provided. The motor will modulate the position of the outside and return air dampers in response to a 4-20 mA or 0-10 VDC analog signal supplied by an external DDC controller. When the unit is off the motor will drive the outside air dampers full closed and the return air dampers full open.
- (u) Two position spring return motor with interlocked outside and return air dampers will be provided. The motor will power the outside air damper full open after a warm up period determined by a minimum supply air temperature sensor when the unit is on, and full closed when the unit is off (ASHRAE Cycle I).
- (w) Modulating motor with interlocked outside and return air dampers will be provided. The motor will modulate the position of the outside and return air dampers in response to a thermostatic controller located in the mixed air stream after a warm up period determined by a minimum supply air temperature sensor. Units will also be provided with a minimum position potentiometer for minimum outside air damper position (ASHRAE Cycle II).

Engineered Products Specification Guide

- (x) Modulating motor with spring return and interlocked outside and return air dampers will be provided. The motor will modulate the position of the outside and return air dampers in response to a thermostatic controller located in the mixed air stream after a warm up period determined by a minimum supply air temperature sensor. Units will also be provided with a minimum position potentiometer for minimum outside air damper position. When the unit is off the motor will drive the outside air dampers full closed and the return air dampers full open (ASHRAE Cycle III).
- (y) Manual outside and return air dampers with manual quadrant will be provided.

P. Accessories

- (a) **Moisture Eliminators.** Moisture eliminators will be provided by the manufacturer to eliminate the possibility of moisture carryover entering the unit through the outside air hood. A differential pressure switch and indicator light will be provided in case of blockage
- (b) **Horizontal Rear Return.** Return air will be located horizontally on the rear of the unit under the outside air inlet. Moisture eliminators will be provided by the manufacturer for the outside air hood.
- (c) **Low Leak Dampers.** Low leak dampers with vinyl blade edge seams and neoprene nylon bushings will be of the galvanized steel opposed blade type.
- (d) **409 Stainless Steel Drip Pan.** Will be provided by the manufacturer in the furnace section.
- (e) **High Altitude Unit.** Unit will be orificed for operation at _____ feet above sealevel elevation. 2 stage units will include a factory installed delay timer allowing the unit to initially fire at 100% for 10 seconds and then operate under the direction of the gas valve controller.
- (f) **High Pressure Regulator.** Will be provided by the manufacturer to reduce the incoming gas pressure to 6 inches of water column.
- (g) **Input Derate.** Unit will be derated _____ % of rated input.
- (h) **Filters.** Will consist of
 - h.1 1 inch Washable Standard
 - h.2 2 inch Washable (Optional)
 - h.3 2 inch Throwaway (Optional)
 - h.4 1 inch 30% Pleated (Optional)
 - h.5 2 inch 30% Pleated (Optional)
- (i) **Evaporative Cooler Accessories** will include:
 - i.1 **Fill and Drain Kit.** Will consist of a 3 way valve and relay for automatic fill and drain operation of the Evaporative Cooler.
 - i.2 **12 inch Celdek® Media.** High Efficiency 12 inch Celdek® Media will be utilized in the Evaporative cooler.
 - i.3 **Freezestat.** An automatic reset freezestat will be provided by the manufacturer to control the operation of the fill and drain kit.
 - i.4 **8 inch Glasdek®.** Will be provided by the manufacturer to conform with UL900 Class II fire rating requirements.
 - i.5 **12 inch Glasdek®.** Will be provided by the manufacturer to conform with UL900 Class II fire rating requirements.
- (j) **7 Day Time Clock.** A 7 day time clock will be provided by the manufacturer and offer SPDT relay output and a maximum of 6 set points per day.
- (k) **24 Hour Time Clock.** A 24 hour time clock will be provided by the manufacturer and offer SPDT relay output and a maximum of 12 set points per day.

- (l) **Clogged Filter Switch.** A factory installed clogged filter switch with indicator light located in the main electrical cabinet or remote control panel (when specified) will be provided by the manufacturer.
- (m) **Convenience Outlet.** A GFI manual reset convenience outlet with weather proof enclosure will be provided by the manufacturer and field installed and require an separate 115 volt service.
- (n) **Remote Control Panel.** A wall mounted "Sterling" design control panel will be provided by the manufacturer. The panel will consist of a non-metallic enclosure and 6 LED status lamps. The lamps will indicate System on/off, Fan on/off, Heat on/off, Cool on/off, Auxiliary on/off (Evaporative cooler on/off or Exhaust fan operation) and modulating damper control (when specified)
- (o) **Manual Blower Switch.** A factory installed manual blower switch located in the electrical cabinet will be provided by the manufacturer.
- (p) **Duct Thermostats**
 - p.1 single stage duct thermostat with an operating range of 55-175° F and SPDT operation will be provided by the manufacturer.
 - p.2 two stage duct thermostat with an operating range of 55-175° F and SPDT operation will be provided by the manufacturer.
- (q) **Room Thermostats**
 - q.1 **T87F Honeywell Thermostat w/Subbase.** A single stage heating and subbase for fan on operation will be provided by the manufacturer.
 - q.2 **T87F Honeywell Thermostat w/Subbase and Guard.** A single stage heating thermostat including a subbase for fan operation and tamper proof guard will be provided by the manufacturer.
 - q.3 **T834H Thermostat with Subbase.** A single stage heating thermostat with fan switch with a 55-95° F operating range will be provided by the manufacturer.
 - q.4 **T7300 Programmable Commercial Thermostat.** The manufacturer will provide a 7 day programmable thermostat capable of 2 stages of heating and 2 stages of cooling.
 - q.5 **T874 Two Stage Thermostat.** The manufacturer will provide a 2 stage heating and 2 stage cooling thermostat with system and fan switching and built in 12° F heating/cooling differential.
 - q.6 **TG511 Locking Thermostat Cover.** A Universal locking thermostat cover will be provided by the manufacturer.
- (r) **Return Firestat.** A return firestat with a setpoint range of 110° - 290° F and SPDT switching capabilities will be provided by the manufacturer.
- (s) **Supply Firestat.** A supply firestat with a setpoint range of 110° - 290° F and SPDT switching capabilities will be provided by the manufacturer.
- (t) **Time Delay Freezestat.** A SPDT time delay freezestat with a setpoint range of 30° - 58° F and a 1 to 5 minute adjustable time delay will be provided by the manufacturer.
- (u) **Ambient Lockout.** A factory mounted ambient lockout control capable of disengaging the duct furnace during times of mild temperatures will be provided by the manufacturer.
- (v) **Interlock Relays.**
 - v.1 **24 Volt DPDT Relay.** A 24 volt type 2 Form C relay with 24 volt coil and DPDT 10 amp contacts will be provided by the manufacturer. The relay will be capable of plugging into the main connection PC board.

Engineered Products Specification Guide

- v.2 **24/115 Volt SPDT Relay.** A relay with selectable coil voltages of 24 or 115 and SPDT 10 amp contacts will be provided by the manufacturer.
- v.3 **24/115/230 Volt DPST Relay.** A relay with selectable coil voltages of 24, 115 or 230 and DPDT 10 amp contacts will be provided by the manufacturer.
- v.4 **24 Volt 4PDT Relay.** A relay with a coil voltage of 24 and 4PDT 10 amp contacts will be provided by the manufacturer.
- (w) **Manual Reset High Limit Switch.** Will be provided by the manufacturer to disengage the furnace at a temperature of 200° F. The switch will be of the non-recycling manual reset type.
- (x) **High /Low Gas Pressure Switches.** Will be provided by the manufacturer to disengage the furnace(s) upon detection of high manifold or low incoming line pressures.
- (y) **Status Lamps.** Long life factory installed LED lamps will be provided in the electrical cabinet by the manufacturer to aid in troubleshooting and equipment setup. Power on, Fan on, Heating energized at furnace one, two or three and cooling energized will be provided when applicable.
- (z) **Air Flow Prove Switch.** Will be provided by the manufacturer to verify airflow through the unit. The switch will be a Dwyer 1910-0 pressure switch suitable for duct mounting with a range of .15 – .50 inches W.C.
- (aa) **Field Installed Disconnect Switches.**
 - aa.1 30 amp fused disconnect switch, NEMA 3R rated, will be provided by the manufacturer to be field mounted.
 - aa.2 30 amp non fused disconnect, NEMA 3R rated, switch will be provided by the manufacturer to be field mounted.
 - aa.3 60 amp fused disconnect switch, NEMA 3R rated, will be provided by the manufacturer to be field mounted.
 - aa.4 60 amp non fused disconnect switch, NEMA 3R rated, will be provided by the manufacturer to be field mounted.
- (bb) **Hinged Access Doors.** Will be provided by the manufacturer on the blower and filter cabinet doors. Doors will be double wall construction and incorporate dual quick opening tool-less latches. Doors stops will be included to prevent against closure while open.
- (cc) **Through-The-Base Utility Penetrations.** Will be provided by the manufacturer. Electric and coil connections will enter the unit in the blower cabinet. The gas connection will enter the duct furnace portion of the unit through the base, the manufacturer will provide pre-engineered piping kit to allow the gas shut off to be accessible from the outside of the duct furnace.
- (dd) **Service Convenience Package.** Will be factory installed by the manufacturer. The service convenience package will consist of a factory mounted switch type disconnect and GFI convenience outlet mounted on a hinged access door. Utility connections will be through-the-base. Hinged access doors will be double wall construction and incorporate dual quick opening tool-less latches. Doors stops will be included to prevent against closure while open. Through-the-base utility penetrations for the electric and coil connections will enter the unit in the blower cabinet. The gas connection will enter the duct furnace portion of the unit through the base, the manufacturer will provide pre-engineered piping kit to allow the gas shut off to be accessible from the outside of the duct furnace.
- (ee) **Double Wall Cabinet Construction.** Will be factory installed and in accordance with the ASHRAE standard no. 62-1989. Double wall construction will be utilized in the Blower, Filtration, Coil and Down Discharge Plenum sections of the unit where applicable. 1" fiber material will be used between the cabinet walls for insulation purposes. Includes Hinged Access Doors.



Unit Selection Procedure

Selection Procedure

Step 1

To properly select a unit, two of the three following items must be known - Temperature Rise (TR) required, Cubic Feet per Minute of air delivery (CFM) required, Output (BTU/H OUT) required. From any two of these items the third item can be determined, as well as the Input (BTU/H IN) required as follows: (The value 1.085 represents a constant.)

$$TR = BTU/H \text{ Out} \div (1.085 \times CFM)$$

$$CFM = BTU/H \div (1.085 \times TR)$$

$$BTU/H \text{ Out} = (CFM \times 1.085) \times TR$$

$$BTU/H \text{ In} = BTU/H \text{ Out} \div \text{Efficiency } .80 \text{ or } .79$$

With any two of the three required values, match these requirements to a unit with the nearest Input (BTU/H), Temperature Rise (TR) and Air Flow (CFM) capabilities keeping in mind that -

$$BTU/H \text{ OUT} = BTU/H \text{ IN} \times \text{Efficiency.}$$

Refer to the "Packaged Rooftop Arrangement Reference" Catalog page 13 to match a Capacity range (BTU/H), Air Delivery (CFM) and Temperature Rise (TR) with a Rooftop Arrangement and proceed to the Chart and Tables listed for that arrangement.

The top portion of Quick Sizer Charts 3,4,5 and 6 allows the use of Temperature Rise and CFM to determine Capacity, or Temperature Rise and Capacity to determine CFM, or Capacity and CFM to determine Temperature Rise. Follow the top chart down to the corresponding filter and cooling range for the selection.

Step 2

Once Capacity, Temperature Rise and CFM have been determined, go to the Accessory Pressure Losses Table for the arrangement and calculate pressure losses for unit accessories. Add the losses for Filters, Plenums, Dampers, Rainhood with Screen or Moisture Eliminators, Evaporative Cooler or Cooling Coil and losses due to Duct Work to determine the Total Static Pressure TSP.

Step 3A 2000 ft. altitude and below

Refer to the Performance Table for the selection and determine RPM and BHP for the total Static Pressure (TSP). Go to the table row that most closely matches unit Capacity, Temperature Rise and CFM, follow the row out to the column that equals the total static pressure TSP for RPM and BHP values.

Step 3B Above 2000 ft. altitude

To correct for Altitude, go to Table 12 Correction Factors for Altitude. From Table 12 determine the correction factor from Temperature and Altitude for the system. Correct the ESP from Duct Work to actual ESP for altitude then add Internal Static Pressure (ISP) from accessories as shown below. Refer to the Performance Table for the selected unit. Go to the row that most closely matches unit Capacity, Temperature Rise and CFM, follow the row out to the column that equals the corrected Actual ESP for RPM and BHP values. The BHP value can now be corrected to Actual BHP for altitude as shown below.

$$\text{Actual TSP} = \text{Duct ESP} \times \text{Factor} + \text{Accs. ISP}$$

$$\text{Actual BHP} = \text{Cat. BHP} \div \text{Factor}$$

Table 12. Correction Factors for Altitude

		Altitude (Feet) and Barometric Pressure (BP) ("In. Hg")							
DESIGN	Altitude	0'	500'	1000'	1500'	2000'	2500'	3000'	
TEMP °F	BP	29.92	29.38	28.86	28.33	27.82	27.31	26.82	
-40		0.79	0.81	0.82	0.84	0.85	0.87	0.88	
0		0.87	0.88	0.90	0.92	0.93	0.95	0.97	
40		0.94	0.96	0.98	1.00	1.01	1.03	1.05	
70		1.00	1.02	1.04	1.06	1.08	1.10	1.12	
80		1.02	1.04	1.06	1.08	1.10	1.12	1.14	
100		1.06	1.08	1.10	1.12	1.14	1.16	1.18	
120		1.90	1.11	1.13	1.16	1.18	1.20	1.22	
DESIGN	Altitude	3500'	4000'	4500'	5000'	5500'	6000'		
TEMP °F	BP	26.32	25.84	25.36	24.9	24.43	23.98		
-40		0.90	0.92	0.93	0.95	0.97	0.99		
0		0.99	1.00	1.02	1.04	1.06	1.08		
40		1.07	1.09	1.11	1.13	1.16	1.18		
70		1.14	1.16	1.18	1.20	1.22	1.25		
80		1.16	1.18	1.20	1.22	1.25	1.27		
100		1.20	1.22	1.25	1.27	1.29	1.32		
120		1.24	1.27	1.29	1.31	1.34	1.37		

Cooling Coil Selection Procedure

Cooling Coils

Cooling coils are used in air handling systems to cool and dehumidify an air stream for comfort purposes. To reduce the cooling load in buildings, most applications recirculate a large percentage of the air. Usually recirculated air is 75-80% of the airflow with the remainder being outside fresh air. Some codes require 100% outside air, particularly for hospitals and schools. Also many engineers specify higher percentages of outside air to meet the requirements of ASHRAE Standard 62-1989 "Ventilation for Acceptable Indoor Air Quality".

A. In order to select the least expensive coil to meet the specified performance criteria the following information is required:

- Unit Size
- Airflow in SCFM or ACFM and Altitude. (see "Fan Selection at Altitude")
- Entering air Dry Bulb and Wet Bulb temperatures based on ratio of outside to return air.
- Cooling load MBH (1000's BTU/Hr) or leaving air Wet Bulb.

B. For chilled water coils the following additional information is required (refer to Tables 9A & 9B):

- Fluid type: water, ethylene glycol, propylene glycol and percent of mixture.
- Entering fluid temperature °F.
- Leaving fluid temperature °F or rate of flow GPM.

Chilled water catalog tables are based on :
45°F entering water temperature.

Entering air temperature of 80° F DB / 67° F WB.
Data is certified in accordance with ARI Standard 410. Capacities based on 95° F DB / 74° F WB information is also shown. For other than these conditions please consult the factory.

C. For DX (refrigerant) coils the following additional information is required (refer to Tables 8A & 8B):

- Refrigerant type.
- Suction temperature °F.
- Liquid temperature °F.
- Type of circuiting desired.
- Hot gas bypass required.

DX catalog tables are based on:
45° F suction temperature.

Entering air temperature of 80° F DB / 67° F WB.
R-22 refrigerant. Capacities based on 95° F DB / 74° F WB information is also shown.

100° F liquid temperature.
Data is certified in accordance with ARI Standard 410. For other than these conditions please consult the factory.

D. When specifying a coil one of the most important pieces of information is the airflow in SCFM. As stated in the "Fan Selection at Altitude" section SCFM means STANDARD CFM or air at a density of 0.075 lb./cu. ft. A fan must be selected using ACFM or ACTUAL CFM. A cooling coil or heating coil must be selected using SCFM. Up to an altitude of approx. 1,500 feet above sea level very little error would be introduced in the selection of a cooling coil. For altitudes above 1,500 feet above sea level the coil must be selected using SCFM. The relationship between ACFM and SCFM is shown by the following equation.

$$SCFM = ACFM \times (\text{Actual Density} \div 0.075)$$

The term "0.075 ÷ Actual Density" is referred to as the density correction factor, here in called the "Factor". This factor can be found in Table 12. The aforementioned equation can then be rewritten as:

$$SCFM = (ACFM \div \text{Factor}).$$

Example: A cooling coil must be selected at 5,000 ft. altitude. The unit delivers 10,000 ACFM. What is the SCFM? At 5,000 ft. altitude, the factor from Table 12 is 1.20 therefore:

$$SCFM = 10,000 \text{ ACFM} \div 1.20 = 8,333 \text{ SCFM}$$

E. The entering air temperatures, both wet bulb and dry bulb must also be considered when selecting a coil. A majority of units usually use recirculated air with a percentage of outside air. The cooling coil must be selected using the mixed air temperature entering the coil.

The following example shows how to calculate the mixed air temperature.

25% Outside air at 95° F DB / 75° F WB
75% recirculated air at 78° F DB / 67° F WB

The mixed dry bulb is simply the proportional value between the outside and recirculated dry bulb temperatures.

$$.25 \times 95 + .75 \times 78 = 82.3^\circ \text{ F}$$

The mixed wet bulb temperatures must be calculated using either the humidity ratio from a psychometric chart or from Table 13 "The enthalpy of saturated air at various wet bulb temperatures".

Using Table 13 the enthalpy of the outside air at 75° F WB is 38.62 BTU/lb. and the recirculated air at 67° F WB is 31.63 BTU/lb. the mixed enthalpy is:

$$.25 \times 38.62 + .75 \times 31.63 = 33.38 \text{ BTU/lb.}$$

Using this value in Table 13 the interpolated wet bulb temperature is 69.1° F

So the final mixed temperatures are: 82.3° F DB / 69.1° F WB

Table 13

Enthalpy of Saturated Air at Various Wet Bulb Temperatures

Wet Bulb Temp.		Wet Bulb Temp.		Wet Bulb Temp.	
Temp.	BTU per Pound	Temp.	BTU per Pound	Temp.	BTU per Pound
50	20.38	60	26.40	70	34.12
50.5	20.64	60.5	26.75	70.5	34.55
51	20.90	61	27.10	71	34.99
51.5	21.17	61.5	27.45	71.5	35.42
52	21.45	62	27.81	72	35.87
52.5	21.73	62.5	28.17	72.5	36.31
53	22.01	63	28.54	73	36.77
53.5	22.29	63.5	28.91	73.5	37.22
54	22.59	64	29.29	74	37.68
54.5	22.88	64.5	29.67	74.5	38.15
55	23.18	65	30.05	75	38.61
55.5	23.48	65.5	30.44	75.5	39.09
56	23.79	66	30.83	76	39.56
56.5	24.10	66.5	31.23	76.5	40.04
57	24.42	67	31.63	77	40.53
57.5	24.74	67.5	32.03	77.5	41.02
58	25.06	68	32.44	78	41.51
58.5	25.39	68.5	32.86	78.5	42.01
59	25.73	69	33.27	79	42.51
59.5	26.06	69.5	33.70	79.5	43.02



Approximate Unit Net and Ship Weights – Table 14

NOTE: ALL UNIT WEIGHTS ARE LESS MOTOR, OUTSIDE AIR HOOD AND COOLING COILS W/ DRAIN PAN

UNIT WEIGHTS

ROOF TOP ARRANGEMENT [RA] "A"					ROOF TOP ARRANGEMENT [RA] "B"						
	<u>NET WT.</u>	<u>SHIP.WT.</u>		<u>NET WT.</u>	<u>SHIP.WT.</u>		<u>NET WT.</u>	<u>SHIP.WT.</u>			
RT-10	256	367	PV-100	262	373	RT-10	576	742	PV-100	583	749
RT-15	307	418	PV-15	298	409	RT-15	627	793	PV-15	619	785
RT-20	365	484	PV-20	356	475	RT-20	740	916	PV-20	731	907
RT-25	405	524	PV-25	395	514	RT-25	781	957	PV-25	771	947
RT-30	469	596	PV-30	455	582	RT-30	907	1092	PV-30	893	1078
RT-35	510	637	PV-35	495	622	RT-35	958	1143	PV-35	943	1128
RT-40	558	690	PV-40	543	675	RT-40	1032	1222	PV-40	1018	1208
RT-50	795	952	PV-50	777	934	RT-50	1195	1423	PV-50	1175	1403
RT-60	914	1081	PV-60	885	1052	RT-60	1377	1616	PV-60	1349	1588
RT-70	994	1161	PV-70	964	1131	RT-70	1468	1707	PV-70	1438	1677
RT-80	1087	1259	PV-80	1058	1230	RT-80	1589	1833	PV-80	1561	1805
RT-12	1617	1820	PV-12	1573	1776						

ROOF TOP ARRANGEMENT [RA] "C"					ROOF TOP ARRANGEMENT [RA] "D"						
	<u>NET WT.</u>	<u>SHIP.WT.</u>		<u>NET WT.</u>	<u>SHIP.WT.</u>		<u>NET WT.</u>	<u>SHIP.WT.</u>			
RT-10	705	923	PV-100	712	930	RT-10	705	904	PV-100	712	911
RT-15	756	974	PV-15	748	966	RT-15	757	956	PV-15	749	948
RT-20	884	1112	PV-20	875	1103	RT-20	893	1102	PV-20	884	1093
RT-25	925	1153	PV-25	915	1143	RT-25	935	1144	PV-25	925	1134
RT-30	1068	1307	PV-30	1054	1293	RT-30	1083	1301	PV-30	1069	1287
RT-35	1117	1356	PV-35	1102	1341	RT-35	1134	1352	PV-35	1119	1337
RT-40	1201	1445	PV-40	1187	1431	RT-40	1220	1443	PV-40	1206	1429
RT-50	1345	1598	PV-50	1325	1578	RT-50	1348	1595	PV-50	1328	1575
RT-60	1546	1811	PV-60	1518	1783	RT-60	1554	1812	PV-60	1526	1784
RT-70	1636	1901	PV-70	1606	1871	RT-70	1644	1902	PV-70	1614	1872
RT-80	1765	2034	PV-80	1737	2006	RT-80	1777	1240	PV-80	1749	2012

ROOF TOP ARRANGEMENT [RA] "E"					ROOF TOP ARRANGEMENT [RA] "G"						
	<u>NET WT.</u>	<u>SHIP.WT.</u>		<u>NET WT.</u>	<u>SHIP.WT.</u>		<u>NET WT.</u>	<u>SHIP.WT.</u>			
RT-10	835	1072	PV-100	842	1079	RT-20	982	1206	PV-20	973	1197
RT-15	886	1123	PV-15	878	1115	RT-25	1025	1249	PV-25	1015	1239
RT-20	1037	1284	PV-20	1028	1275	RT-30	1218	1452	PV-30	1204	1438
RT-25	1078	1325	PV-25	1068	1315	RT-35	1261	1495	PV-35	1246	1480
RT-30	1244	1502	PV-30	1230	1488	RT-40	1343	1583	PV-40	1329	1569
RT-35	1294	1552	PV-35	1279	1537	RT-50	1427	1689	PV-50	1407	1669
RT-40	1389	1652	PV-40	1375	1638	RT-60	1677	1951	PV-60	1649	1923
RT-50	1499	1785	PV-50	1479	1765	RT-70	1759	2033	PV-70	1729	2003
RT-60	1722	2020	PV-60	1694	1992	RT-80	1886	2166	PV-80	1858	2138
RT-70	1812	2110	PV-70	1782	2080	RT-12	2420	2741	PV-12	2376	2697
RT-80	1953	2257	PV-80	1925	2229						

ROOF TOP ARRANGEMENT [RA] "J"					ROOF TOP ARRANGEMENT [RA] "K"						
	<u>NET WT.</u>	<u>SHIP.WT.</u>		<u>NET WT.</u>	<u>SHIP.WT.</u>		<u>NET WT.</u>	<u>SHIP.WT.</u>			
RT-20	1116	1378	PV-20	1107	1369	RT-10	886	1137	PV-100	893	1144
RT-25	1157	1419	PV-25	1147	1409	RT-15	937	1188	PV-15	929	1180
RT-30	1367	1641	PV-30	1353	1627	RT-20	1132	1394	PV-20	1123	1385
RT-35	1409	1683	PV-35	1394	1668	RT-25	1174	1436	PV-25	1164	1426
RT-40	1499	1779	PV-40	1485	1765	RT-30	1385	1659	PV-30	1371	1645
RT-50	1597	1898	PV-50	1577	1878	RT-35	1428	1702	PV-35	1413	1687
RT-60	1863	2177	PV-60	1835	2149	RT-40	1519	1799	PV-40	1505	1785
RT-70	1944	2258	PV-70	1914	2228	RT-50	1614	1915	PV-50	1594	1934
RT-80	2079	2400	PV-80	2051	2372	RT-60	1881	2195	PV-60	1853	2207
RT-12	2620	2981	PV-12	2576	2937	RT-70	1964	2278	PV-70	1934	2288
						RT-80	2099	2420	PV-80	2071	2432

Approximate Unit Net and Ship Weights – Table 14

ROOF TOP ARRANGEMENT [RA] "L"						OUTSIDE AIR HOOD W/BIRD SCREEN WEIGHT ADDER	
	NET WT.	SHIP.WT.		NET WT.	SHIP.WT.	Capacity [CA]	
RT-10	1055	1344	PV-100	1062	1351	10	43
RT-15	1106	1395	PV-15	1098	1387	15	43
RT-20	1316	1617	PV-20	1307	1608	20	51
RT-25	1358	1659	PV-25	1348	1649	25	51
RT-30	1589	1903	PV-30	1575	1889	30	59
RT-35	1630	1944	PV-35	1615	1929	35	59
RT-40	1730	2051	PV-40	1716	2037	40	63
RT-50	1756	2096	PV-50	1736	2076	50	51
RT-60	2043	2397	PV-60	2015	2369	60	59
RT-70	2125	2479	PV-70	2095	2449	70	59
RT-80	2269	2630	PV-80	2241	2602	80	63

Air Handler Arrangements

ROOF TOP ARRANGEMENT [RA] "M"

Capacity [CA]	NET WT.	SHIP.WT.
20	403	616
40	513	744

ROOF TOP ARRANGEMENT [RA] "N"

Capacity [CA]	NET WT.	SHIP.WT.
20	529	705
40	665	855

ROOF TOP ARRANGEMENT [RA] "P"

Capacity [CA]	NET WT.	SHIP.WT.
20	609	822
40	769	1000

ROOF TOP ARRANGEMENT [RA] "R"

Capacity [CA]	NET WT.	SHIP.WT.
20	735	959
40	921	1161

ROOF TOP ARRANGEMENT [RA] "S"

Capacity [CA]	NET WT.	SHIP.WT.
20	635	847
40	793	1023

ROOF TOP ARRANGEMENT [RA] "T"

Capacity [CA]	NET WT.	SHIP.WT.
20	788	1012
40	967	1207

ROOF TOP ARRANGEMENT [RA] "U"

Capacity [CA]	NET WT.	SHIP.WT.
20	797	1021
40	987	1227

ROOF TOP ARRANGEMENT [RA] "W"

Capacity [CA]	NET WT.	SHIP.WT.
20	936	1198
40	1152	1432

APPROXIMATE MOTOR SHIPPING WEIGHT - ADD TO THE TOTAL UNIT/SHIP WEIGHTS

MOTOR TYPE [MT]	1, OPEN DRIP PROOF				1, OPEN DRIP PROOF				2, TOTALLY ENCLOSED		
	1, 115/1/60	2, 208/1/60	3, 230/1/60	4, 208/3/60	5, 230/3/60	6, 460/3/60	7, 575/3/60	1, 115/1/60	2, 208/1/60	3, 230/1/60	
MOTOR SIZE [MS]											
C,L 1 HP	15	32	32	41	41	41	40	32	32	32	
D,M 1 1/2 HP	18	40	40	43	43	43	43	41	41	41	
E,N 2 HP	19.4	41	41	49	49	49	49	70	70	54	
G,P 3 HP	-	-	-	72	72	72	72	76	76	76	
H,R 5 HP	-	-	-	76	76	76	89	-	-	-	
S 7-1/2 HP	-	-	-	120	120	120	118	-	-	-	
T 10 HP	-	-	-	141	141	141	141	-	-	-	
U 15 HP	-	-	-	217	217	217	234	-	-	-	

Note: All Rooftop Arrangement weights are less motor, outside air hood, cooling coil and drain pan.



Roof Curb Kits – Approximate Ship Weights (lbs.)

†Kit Number	Rooftop Arrangement [RA]	Capacity [CA]	†Roof Curb Kit Suffix Number			
			-1	-2	-3	-4
RC001	B	10 thru 40	115	133	151	161
	N	20, 40				
RC002**	D	10 thru 40	145	163	181	191
	R	20, 40				
RC003	B	50 thru 80	150	168	186	196
	C	10 thru 40				
RC004**	D	50 thru 80	180	198	216	226
	E	10 thru 40				
RC005	G	50 thru 80	192	210	228	238
	J	20 thru 40				
	K	10 thru 40				
	W	20, 40				
RC006	G	20 thru 40	N/A	179	197	207
	T	20, 40				
	U	20, 40				
RC007	C	50 thru 80	N/A	197	217	227
RC008**	E	50 thru 80	N/A	227	247	257
RC009	G	12	310	338	366	381
	J & K	50 thru 80				
	L	10 thru 40				
RC010	J	12	N/A	375	403	418
	L	50 thru 80				
RC011	M	20, 40	N/A	85	N/A	112
RC012**	P	20,40	N/A	115	N/A	142
RC013	S	20, 40	N/A	140	N/A	168
RC015*	“EV” Evaporative Cooler Platform Only	10 thru 80	30 (one platform kit fits all capacities)			

Roof Curb Ductwork Adapter Kits

	Usage per Roof Curb Kit	†Roof Curb Kit Suffix Number			
RC016*** Return Air	RC001 thru RC013	5	6	6	7
RC017†† Supply Air	RC001, RC002, RC003, RC004, RC007, RC008	10	11	11	12
RC018†† Supply Air	RC005, RC006, RC009, RC010	10	11	11	12

* For use with “EV” evaporative cooler only.

** Roof Curb Kits RC002, RC004, RC008 and RC012 include the evaporative cooler platform.

***For units equipped with a return air opening.

Metric Conversions: One pound equals 0.453 kilograms.

N/A = Not Applicable

† These weights also apply to the Uninsulated Roof Curb Kits URC001 - URC013.

†† For use with unit arrangements equipped with supply plenums.

† Curb Kit Suffix Legend	
Capacity	Suffix
10, 15	-1
20, 25, 50	-2
30, 35, 60, 70	-3
40, 80, 12	-4

Motor Electrical Data – Table 16

FULL - LOAD CURRENT IN AMPERES

Open Drip Proof
Single Speed, 1800 RPM ODP

H.P.	115/1/60	208/1/60	230/1/60	208/3/60	230/3/60	460/3/60	575/3/60
0.5	9.8	5.4	4.9	2.2	2.0	1.0	0.8
0.8	13.8	7.6	6.9	3.1	2.8	1.4	1.1
1.0	16.0	8.8	8.0	4.0	3.6	1.8	1.4
1.5	20.0	11.0	10.0	5.7	5.2	2.6	2.1
2.0	24.0	13.2	12.0	7.5	6.8	3.4	2.7
3.0	34.0	18.7	17.0	10.6	9.6	4.8	3.9
5.0	56.0	30.8	28.0	16.7	15.2	7.6	6.1
7.5	-	-	-	24.2	22.0	11.0	9.0
10.0	-	-	-	30.8	28.0	14.0	11.0
15.0	-	-	-	46.2	42.0	21.0	17.0

High Efficiency Single Speed, 1800 RPM PE					Totally Enclosed Fan Cooled Single Speed, 1800 RPM TEFC				
H.P.	208/3/60	230/3/60	460/3/60	575/3/60	H.P.	208/3/60	230/3/60	460/3/60	575/3/60
1.0	3.6	2.8	1.4	1.1	1.0	3.5	3.6	1.8	1.5
1.5	5.0	3.8	1.9	1.8	1.5	4.8	4.7	2.4	1.9
2.0	6.7	5.4	2.7	2.3	2.0	6.0	5.8	2.9	2.3
3.0	9.2	8.0	4.0	3.2	3.0	9.0	8.8	4.4	3.5
5.0	14.7	12.8	6.4	5.2	5.0	14.0	13.2	6.6	5.3
7.5	22.1	19.2	9.6	7.7	7.5	21.0	20.0	10.0	8.0
10.0	29.0	25.2	12.6	10.1	10.0	28.0	27.0	13.5	10.8
15.0	40.0	36.0	18.0	14.5	15.0	41.0	38.6	19.3	15.4

Open Drip Proof

2 Speed 1 Winding, 1800/900 RPM				2 Speed 2 Winding, 1800/1200 RPM			
HP.	208/3/60	230/3/60	460/3/60	HP.	208/3/60	230/3/60	460/3/60
1.0	3.3/1.5	3.2/1.4	1.6/0.7	1.0	3.4/2.1	3.2/2.0	1.5/1.0
1.5	5.0/2.2	4.8/2.0	2.4/1.0	1.5	5.0/2.6	4.8/2.9	2.3/1.3
2.0	6.5/2.9	6.3/2.6	3.2/1.3	2.0	6.5/3.6	6.3/3.5	3.0/1.7
3.0	9.0/3.4	8.0/3.3	3.8/1.6	3.0	9.3/4.9	8.5/4.6	4.6/2.7
5.0	15.0/6.2	14.0/6.0	6.8/2.8	5.0	14.5/7.3	13.0/7.0	6.5/4.0
7.5	21.0/7.5	19.5/7.5	10.0/4.0	7.5	20.0/11.0	19.0/10.0	10.5/5.5
10.0	29.0/9.6	25.0/9.3	12.0/4.3	10.0	27.0/14.0	25.0/12.5	13.5/7.2
15.0	42.0/18.0	38.0/14.0	18.0/6.0	15.0	45.5/27.5	41.0/23.0	20.5/11.5

NOTES: Full Load Current for Motors is Based Upon The National Electrical Code 1993 Article - 430, Tables 148-150.

Full Load Current May Vary for Some Motors, Refer to the Motor Data Plate when Setting Over Current Protection Devices.

575 Volt Two Speed Motors Special Order.



Mestek

Mestek's corporate headquarters is located in Westfield, Massachusetts, the same location where Company operations began in 1946.

Mestek is a large and growing multidivisional Company that holds a leadership position in the residential and commercial building finned-tube heating equipment industry. It has become a major supplier of gas-fired heating equipment and is a leading manufacturer of fire, smoke, and air control dampers used in the HVAC systems of office buildings, hospitals, and schools. In addition, it is rapidly building toward a leadership position as a manufacturer of coil stock handling systems for the metal stamping and forming industries.

Mestek's products are built at eleven modern manufacturing facilities located in Maine, Massachusetts, Texas, Ohio, North Carolina, Georgia, California, Maryland, Pennsylvania, Connecticut and Michigan. A nationwide network of aggressive, experienced sales representatives, distributors, and wholesalers keep Mestek products flowing to the marketplace.

The Mestek products meet the stringent performance standards of American Gas Association, Canadian Gas Association, Underwriters Laboratory, ETL, and other highly regarded industry associations. Building at this level of quality while paying attention to cost has consistently given Mestek products extra appeal in the marketplace.

The Company's representatives and wholesalers have been carefully selected to assure the highest possible level of product experience and knowhow. The competence and product knowledge of the headquarters staff is unmatched. Thus whatever the product or where ever you're located, specifying Mestek gives you the combination of top quality and complete technical support with the application of the product.

SALES OFFICE:

260 North Elm Street, Westfield, Mass. 01085
(413) 564-5540 • Fax (413) 562-5311
www.sterlinghvac.com

LIMITED WARRANTY

Sterling Gas Fired Products are warranted by Sterling to be free from defects in material and workmanship for a period of one (1) year from the date of shipment from Sterling's Plant.

Sterling will repair or replace, at its option, any components which, upon inspection, it finds to be defective, provided that the unit has been operated within its listed capacity, installed in accordance with the furnished instructions, has not been misused or subject to negligence and has received reasonable and necessary maintenance. This warranty does not cover labor or other costs incurred in repairing, removing, installing, servicing or handling of parts or complete products.

This warranty does not cover loss due to corrosion by chemicals precipitated in the air such as halogenated hydrocarbons.

Sterling will in no event be liable for incidental or consequential damages of any kind.

The buyer must request written permission from Sterling to return defective components and then must send them with all transportation charges prepaid to the plant designated in the written permission.

This warranty is extended only to the original owner of the unit.

REPLACEMENT PARTS

Replacement parts are available for all current and most obsolete Sterling Gas Fired Products. See list price sheets EPRP and RRPC for listing and prices.

In the interest of product improvement Sterling reserves the right to make changes without notice.

Engineered Products Model Number Description

Digit	E	X	X	—	1	2	3	4	5	6	7	8	9	10	11	12	13	14	15	16	+
Item	Prefix				UT	CA		FT	FM	RA	CO	GT	GC	SV	MT	MS	AI	AC	AS		

(Internal Use Only)

1, 2 - Unit Type [UT]

RT - Natural Vent Rooftop
 PV - Power Vented Rooftop
 AH - Air Handler
 EV - Evaporative Cooler Only

3, 4 - Capacity [CA]

Single Furnace

10 - 100,000 BTU/HR
 15 - 150,000 BTU/HR
 20 - 200,000 BTU/HR
 25 - 250,000 BTU/HR
 30 - 300,000 BTU/HR
 35 - 350,000 BTU/HR
 40 - 400,000 BTU/HR

Double Furnace

50 - 500,000 BTU/HR
 60 - 600,000 BTU/HR
 70 - 700,000 BTU/HR
 80 - 800,000 BTU/HR

Triple Furnace

12 - 1,200,000 BTU/HR

5 - Furnace Type [FT]

A - Standard Temperature Rise (20-60 F Deg.), Right Side Access
 B - Standard Temperature Rise (20-60 F Deg.), Left Side Access
 C - High Temperature Rise (60-90 F Deg.), Right Side Access
 D - High Temperature Rise (60-90 F Deg.), Left Side Access
 O - None
 Z - Other

6 - Furnace Construction Material [FM]

1 - Aluminized Steel
 2 - 409 Stainless Steel (First Furnace Only)
 3 - 409 Stainless Steel (All Furnace Sections)
 4 - 321 Stainless Steel (First Furnace Only)
 5 - 321 Stainless Steel (All Furnace Sections)
 6 - 409 Stainless Steel Package (First Furnace Only)
 7 - 409 Stainless Steel Package (All Furnace Sections)
 8 - 321 Stainless Steel Package (First Furnace Only)
 9 - 321 Stainless Steel Package (All Furnace Sections)
 O - None
 Z - Other

7 - Rooftop Arrangement (B-L assumes furnace section(s)) [RA]

A - Duct Furnace	M - Air Handler (Standard)
B - Blower (Standard)	N - Air Handler (Standard) / Plenum
C - Blower (Standard) / Plenum	P - Air Handler (Standard) / Evap. Cooling
D - Blower (Standard) / Evap. Cooling	R - Air Handler (Standard) / Evap. Cooling / Plenum
E - Blower (Standard) / Evap. Cooling / Plenum	S - Air Handler (High CFM)
G - Blower (High CFM)	T - Air Handler (High CFM) / Plenum
J - Blower (High CFM) / Plenum	U - Air Handler (High CFM) / Coil Cabinet
K - Blower (High CFM) / Coil Cabinet	W - Air Handler (High CFM) / Coil Cabinet / Plenum
L - Blower (High CFM) / Coil Cabinet / Plenum	O - None
	Z - Other

8 - Coil Options [CO]

A - DX Coil, 4 Row Single Circuit	E - Chilled Water Coil, 4 Row
B - DX Coil, 4 Row Dual Circuit	G - Chilled Water Coil, 6 Row
C - DX Coil, 6 Row Single Circuit	O - None
D - DX Coil, 6 Row Dual Circuit	Z - Other

9 - Gas Type [GT]

1 - Natural Gas
 2 - Propane Gas (LP)
 3 - Natural Gas w/100% Lockout
 O - None

10 - Gas Control [GC]

A - Single Stage Gas (Standard)
 B - Two Stage Gas
 C - Mechanical Modulation (60-100)
 D - Mechanical Modulation (75-200)
 F - Mechanical Modulation w/Bypass & Limit (60-100)
 G - Mechanical Modulation w/Bypass (75-200)
 H - Electronic Modulation w/Room Sensing
 J - Electronic Modulation w/Duct Sensing
 K - Electronic Modulation w/Duct Sensing & Ovrd. Stat
 L - Electronic Modulation w/External 4-20 mA Input (Furnace One)
 M - Electronic Modulation w/External 4-20 mA Input (All Furnaces)
 N - Electronic Modulation w/External 0-10 VDC Input (Furnace One)
 P - Electronic Modulation w/External 0-10 VDC Input (All Furnaces)
 R - Two Stage Remote Temperature Control w/Duct Sensor
 S - Three Stage Remote Temperature Control w/Duct Sensor
 T - Four Stage Remote Temperature Control w/Duct Sensor
 U - S-350 2 Stage Modular Electronic Control System
 W - S-350 3 Stage Modular Electronic Control System
 X - S-350 4 Stage Modular Electronic Control System
 Y - S-350 6 Stage Modular Electronic Control System
 O - None
 Z - Other

11 - Supply Voltage [SV]

1 - 115/1/60	5 - 230/3/60
2 - 208/1/60	6 - 460/3/60
3 - 230/1/60	7 - 575/3/60
4 - 208/3/60	O - None
	Z - Other

12 - Motor Type [MT]

1 - Open Drip Proof (Standard)
 2 - Totally Enclosed
 3 - Premium Efficiency, Open Drip Proof
 4 - Premium Efficiency, Totally Enclosed
 5 - Two Speed One Winding, Open Drip Proof
 6 - Two Speed Two Winding, Open Drip Proof
 O - None
 Z - Other

13 - Motor Sizes [MS]

A - 1/2 HP. w/Contactor	M - 1-1/2 HP. w/Magnetic Starter
B - 3/4 HP. w/Contactor	N - 2 HP. w/Magnetic Starter
C - 1 HP. w/Contactor	P - 3 HP. w/Magnetic Starter
D - 1-1/2 HP. w/Contactor	R - 5 HP. w/Magnetic Starter
E - 2 HP. w/Contactor	S - 7-1/2 HP. w/Magnetic Starter
G - 3 HP. w/Contactor	T - 10 HP. w/Magnetic Starter
H - 5 HP. w/Contactor	U - 15 HP. w/Magnetic Starter
J - 1/2 HP. w/Magnetic Starter	O - None
K - 3/4 HP. w/Magnetic Starter	Z - Other
L - 1 HP. w/Magnetic Starter	

14 - Air Inlet Configuration [AI]

1 - Outside Air (OA) (Horiz. Inlet)	4 - Outside Air and Return Air (OA/RA)
2 - Outside Air w/Air Hood (Horiz. Inlet)	5 - Outside and Return Air w/Air Hood
3 - Bottom Return Air (RA)	O - None
	Z - Other

15 - Air Control & Damper Arrangement [AC]

A - Outside Air 2 Pos. Motor / Spring Return
 B - Return Air 2 Pos. Motor / Spring Return
 C - OA/RA 2 Pos. / Spring Return
 D - OA/RA Mod. Mtr. w/Mixed Air Control / Min. Pot.
 E - OA/RA Mod. Mtr. w/Mixed Air Control / Min. Pot. / SR
 G - OA/RA Mod. Mtr. w/Mixed Air Control
 H - OA/RA Mod. Mtr. w/Mixed Air Control / SR
 J - OA/RA Mod. Mtr. w/Min. Pot.
 K - OA/RA Mod. Mtr. w/Min. Pot. / SR
 L - OA/RA Mod. Mtr. w/Dry Bulb / Mixed Air Control / Min. Pot.
 M - OA/RA Mod. Mtr. w/Dry Bulb / Mixed Air Control / Min. Pot. /SR
 N - OA/RA Mod. Mtr. w/Enthalpy Controlled Evaporator / SR
 P - OA/RA Mod. Mtr. w/Pressure Control (Space Pressure)
 R - OA/RA Mod. Mtr. w/S-350-P Proportional Mixed Air Control / SR
 S - OA/RA Mod. Mtr. w/0-10 VDC & 4-20 mA Analog Input (External Input)
 T - OA/RA Mod. Mtr. w/0-10 VDC & 4-20 mA Analog Input / SR (External Input)
 U - ASHRAE Cycle I (OA/RA 2 Pos. Mtr. w/Warm-up Stat / SR)
 W - ASHRAE Cycle II (OA/RA Mod. Mtr. w/Warm-up Stat / Mixed Air / Min. Pot. / SR)
 X - ASHRAE Cycle III (OA/RA Mod. Mtr. w/Warm-up Stat / Mixed Air / SR)
 Y - Manual Dampers
 O - None
 Z - Other

MOD = Modulating Damper Motor
 OA = Outside Air RA = Return Air SR = Spring Return

16 - Accessories [AS]

A1 - Moisture Eliminators	G1 - Thermostat - T87F w/Subbase
A2 - Horizontal Return	G2 - Thermostat - T87F w/Subbase & Guard
A3 - Low Leak Damper	G3 - Thermostat - T834H w/Subbase (Sterling Star)
A5 - Furnace Drip Pan, 409 Stainless	G4 - Thermostat - T7300 - 7 Day Programmable
A6 - High Altitude Unit	G5 - Thermostat - T874 (Two Stage)
A7 - High Pressure Regulator	G6 - Locking Thermostat Cover
A8 - Input Derate	
B1 - Filters - 1" WA (Standard)	H1 - Return Firestat
B2 - Filters - 2" WA	H2 - Supply Firestat
B3 - Filters - 2" TA	H3 - Time Delay Freezestat
B4 - Filters - 1" 30%	H4 - Ambient Lockout
B5 - Filters - 2" 30%	
C1 - Evap. Cooler - Fill & Drain Kit	J1 - Interlock Relay - 24V Coil DPDT 10A, Plug-in
C2 - Evap. Cooler - 12" CELdek® Media	J2 - Interlock Relay - 24/115V Coil SPDT 10A
C3 - Evap. Cooler - Freezestat	J3 - Interlock Relay - 24/115/230V Coil DPDT 10A
C4 - 8" GLASdek® Media	J4 - Interlock Relay - 24V Coil 4PDT 10A
C5 - 12" GLASdek® Media	
D1 - Status Lamp (Elec. Cabinet)	K1 - Manual Reset High Limit Switch
D2 - Time Clock - 24 Hour	K2 - High / Low Gas Pressure Limit Switches
E1 - Clogged Filter Switch	K3 - Status Lamp (Elec. Cabinet)
E2 - G.F.I. Convenience Outlet 115VAC	K4 - Fan Time Delay (Arrangement A Only)
E3 - Remote Control Panel	K5 - Air Flow Prove Switch
E4 - Manual Blower Switch	
F1 - Ductstat - One Stage	L1 - 30 Amp, Fused Disconnect Switch
F2 - Ductstat - Two Stage	L2 - 30 Amp, Non Fused Disconnect Switch
	L3 - 60 Amp, Fused Disconnect Switch
	L4 - 60 Amp, Non Fused Disconnect Switch
	N1 - Hinged Access Door(s)
	N2 - Through the Base Utility Penetration
	N3 - Service Convenience Package
	N6 - Double Wall Construction
	O - None
	Z1 - Other (Specify)

* Note: N6 includes N1

Packaged Rooftop Arrangement Reference

Unit Types [UT] RT or PV

†These CFM ranges shown for Arrangements K & L are for the cooling mode operation; see Performance Data on pages 22 through 25 for heating mode specifications.

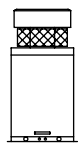
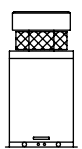
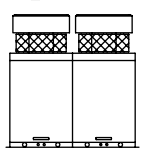
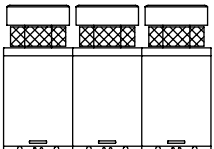
	Standard Blower Rooftop Arrangements B, C	Standard Blower w/Evap. Rooftop Arrangements D, E	High CFM Blower Rooftop Arrangements G, J	High CFM Blower w/Cooling Rooftop Arrangements K, L
Furnace Type A, B $\Delta T_{20} - 60F^*$  [QV(RT/PV)-100/400H]	Capacity 10 - 40 10 - 1,200-3,500 CFM, 1/2 - 5 HP. 15 - 2,000-4,500 CFM, 1/2 - 5 HP. 20 - 2,500-5,500 CFM, 1/2 - 5 HP. 25 - 3,000-5,500 CFM, 3/4 - 5 HP. 30 - 3,700-7,000 CFM, 3/4 - 5 HP. 35 - 4,500-8,500 CFM, 3/4 - 5 HP. 40 - 5,000-8,500 CFM, 1 - 5 HP. ESP 0.1 - 2.0 in. WC Chart #3 Tables #2,4	Capacity 10 - 40 10 - 1,200-3,500 CFM, 1/2 - 5 HP. 15 - 2,000-4,500 CFM, 1/2 - 5 HP. 20 - 2,500-5,500 CFM, 1/2 - 5 HP. 25 - 3,000-5,500 CFM, 3/4 - 5 HP. 30 - 3,700-7,000 CFM, 3/4 - 5 HP. 35 - 4,500-8,500 CFM, 3/4 - 5 HP. 40 - 5,000-8,500 CFM, 1 - 5 HP. ESP 0.1 - 2.0 in. WC Chart #3 Tables #2,4	Capacity 20 - 40 20 - 2,500-7,400 CFM, 3/4 - 10 HP. 25 - 3,100-7,500 CFM, 3/4 - 10 HP. 30 - 3,700-11,000 CFM, 1/2 - 15 HP. 35 - 4,500-13,000 CFM, 3/4 - 15 HP. 40 - 5,000-14,000 CFM, 1 - 15 HP. ESP 0.1 - 2.0 in. WC Chart #5 Tables #5,7	Capacity 10 - 40 10 - 960-3,000 CFM, 1/2 - 5 HP. 15 - 960-3,000 CFM, 1/2 - 5 HP. 20 - 1,600-4,400 CFM, 3/4 - 10 HP. 25 - 1,600-4,400 CFM, 3/4 - 10 HP. 30 - 1,900-5,700 CFM, 1/2 - 15 HP. 35 - 1,900-5,700 CFM, 3/4 - 15 HP. 40 - 2,100-6,300 CFM, 1 - 15 HP. ESP 0.1 - 2.0 in. WC Chart #5 Tables #5,7,8,9
Furnace Type C, D $\Delta T_{60} - 90F^*$  [QV(RT/PV)-100/400]	Capacity 10-40 10 - 800-1,200 CFM, 1/2 - 1-1/2HP. 15 - 1,200-1,800 CFM, 1/2 - 2 HP. 20 - 1,600-2,400 CFM, 1/2 - 2 HP. 25 - 2,000-3,000 CFM, 1/2 - 3 HP. 30 - 2,400-3,600 CFM, 1/2 - 5 HP. 35 - 2,800-4,200 CFM, 1/2 - 5 HP. 40 - 3,200-4,800 CFM, 1/2 - 5 HP. ESP 0.1 - 2.0 in. WC Chart #4 Tables #3,4	Capacity 10-40 10 - 800-1,200 CFM, 1/2 - 1-1/2HP. 15 - 1,200-1,800 CFM, 1/2 - 2 HP. 20 - 1,600-2,400 CFM, 1/2 - 2 HP. 25 - 2,000-3,000 CFM, 1/2 - 3 HP. 30 - 2,400-3,600 CFM, 1/2 - 5 HP. 35 - 2,800-4,200 CFM, 1/2 - 5 HP. 40 - 3,200-4,800 CFM, 1/2 - 5 HP. ESP 0.1 - 2.0 in. WC Chart #4 Tables #3,4	NA	Capacity 20 - 40 20 - 1,600-2,400 CFM, 1/2 - 2 HP. 25 - 1,600-3,000 CFM, 1/2 - 2 HP. 30 - 1,900-3,600 CFM, 1/2 - 5 HP. 35 - 1,900-4,200 CFM, 1/2 - 5 HP. 40 - 2,100-5,000 CFM, 1/2 - 5 HP. ESP 0.1 - 2.0 in. WC Chart #6 Tables #6,7,8,9
Furnace Type A, B $\Delta T_{40} - 120F^*$ 	Capacity 50 - 80 50 - 3,000-5,500 CFM, 1 - 5 HP. 60 - 3,700-6,500 CFM, 1 - 5 HP. 70 - 4,500-8,000 CFM, 1 - 5 HP. 80 - 5,000-8,000 CFM, 1 - 5 HP. ESP 0.1 - 2.0 in. WC Chart #3 Tables #2,4	Capacity 50 - 80 50 - 3,000-5,500 CFM, 1 - 5 HP. 60 - 3,700-6,500 CFM, 1 - 5 HP. 70 - 4,500-8,000 CFM, 1 - 5 HP. 80 - 5,000-8,000 CFM, 1 - 5 HP. ESP 0.1 - 2.0 in. WC Chart #3 Tables #2,4	Capacity 50 - 80 50 - 3,100-7,500 CFM, 1 - 10 HP. 60 - 3,700-11,000 CFM, 3/4 - 15 HP. 70 - 4,500-13,000 CFM, 1 - 15 HP. 80 - 5,000-13,500 CFM, 1 - 15 HP. ESP 0.1 - 2.0 in. WC Chart #5 Tables #5,7	Capacity 50 - 80 50 - 1,600-4,400 CFM, 1 - 10 HP. 60 - 1,900-5,700 CFM, 3/4 - 15 HP. 70 - 1,900-5,700 CFM, 1 - 15 HP. 80 - 2,100-6,300 CFM, 1 - 15 HP. ESP 0.1 - 2.0 in. WC Chart #5 Tables #5,7,8,9
Furnace Type A, B $\Delta T_{60} - 180F^*$ 	NA	NA	Capacity 12 12 - 5,500-13,000 CFM, 1-1/2 - 15 HP. ESP 0.1 - 2.0 in. WC Chart #5 Tables #5,7	NA

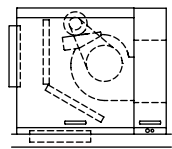
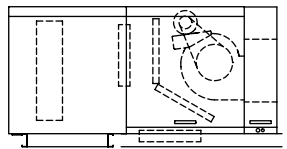
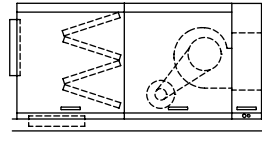
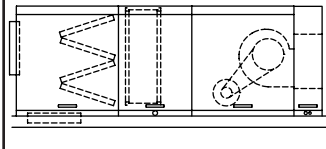
Standard Blower Rooftop Arrangements M, N	Standard Blower w/Evap. Rooftop Arrangements P, R	High CFM Blower Rooftop Arrangements S, T	High CFM Blower w/Cooling* Rooftop Arrangements U, W
 Capacity 20, 40 20 - 1,500-6,000 CFM, 1/2-5 HP. 40 - 4,000-8,000 CFM, 1/2-5 HP. ESP. 0.1 - 3.0 in. WC. Tables # 10, 4	 Capacity 20, 40 20 - 1,500-6,000 CFM, 1/2-5 HP. 40 - 4,000-8,000 CFM, 1/2-5 HP. ESP. 0.1 - 3.0 in. WC. Tables # 10, 4	 Capacity 20, 40 20 - 3,000-8,000 CFM, 3/4-10 HP. 40 - 5,000-14,000 CFM, 3/4-15 HP. ESP. 0.1 - 3.0 in. WC. Tables # 11, 7	 Capacity 20, 40 20 - 1,600-4,400 CFM, 3/4-10 HP. 40 - 2,100-6,300 CFM, 3/4-15 HP. ESP. 0.1 - 3.0 in. WC. Tables # 11, 7, 8, 9

* The maximum CFM for Rooftop Arrangements K, L, U and W is 6,300 (3.0 m³/s). A two speed motor may be utilized for non-cooling air flow up to 14,000 CFM (6.6 m³/s).

Notes

Unless otherwise specified, the following conversions may be used for calculating SI unit measurements:

1 cubic foot = 0.028 m³

1 foot = 0.305 m

1 inch = 25.4 mm

1 psig = 6.894 kPa

1 inch water column = 0.249

1 pound = 0.453 kg

1,000 Btu per hour = 0.293 kW

Liter/second = CFM x 0.472

Meter/second = FPM ÷ 196.8

1,000 Btu/Cu. Ft. = 37.5 MJ/m³

1 gallon = 3.785 L



260 North Elm Street, Westfield, MA 01085
TEL: 413-564-5540 • FAX: 413-562-5311
www.sterlinghvac.com

 A MESTEK COMPANY