



SENIOR

Submittal

High Capacity
Baseboard Radiation

Specification

ENCLOSURE:

STYLE : "Senior"

COLOR: White

FRONT: 20 Ga. Roll Formed
Prepainted Steel

18 Ga. Optional

BACKPLATE:

22 Ga. Roll Formed
Prepainted Steel

DAMPER VANE:

Roll Formed
Prepainted Steel

ELEMENT:

TYPE: Cu/Al Mechanically
Expanded
Flared One End

BRACKETS:

Die Formed 16 Ga.
Prepainted Steel

SLIDE SHOES:

High Temperature
Nylon Snap On

ACCESSORIES:

All overlapping
20 Ga. Steel with
Snap On Fit and
Baked Enamel Finish

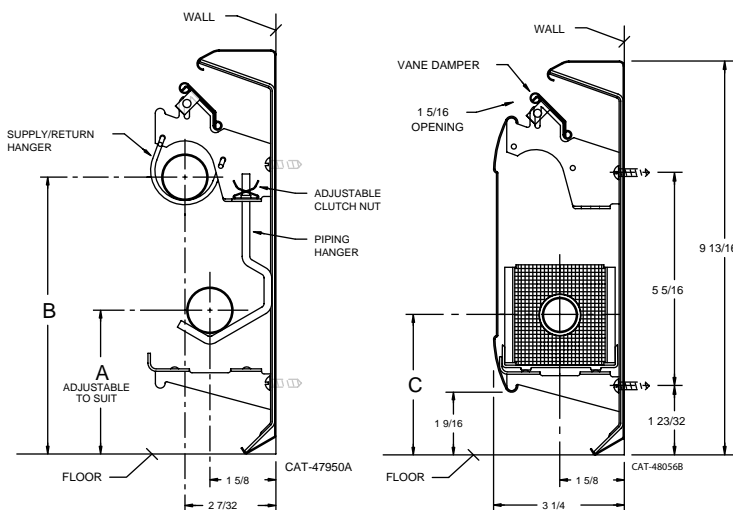

RATINGS



Element 2 3/4" x 2 1/2" Fin	Water Rate GPM	Average Hot Water Temperature °F - BTU/Hr./Lin. Ft.							
		150°	160°	170°	180°	190°	200°	210°	220°
SR-3/4-55, 3/4" Tube (Cu.)	1	500	580	660	740	830	910	990	1070
55 Fins (.011)/Ft.	4	530	610	700	780	880	960	1050	1130
SR-1-55, 1" Tube (Cu.)	1	460	540	620	700	780	850	930	1010
55 Fins (.011)/Ft.	4	490	570	660	740	820	900	980	1070
Element 2 3/4" x 3 3/4" Fin (plain edge fin supplied and not IBR rated)									
1 1/4" Tube (Cu.)	1	510	590	670	750	850	920	1010	1110
50 Fins (.020)/Ft.	4	540	620	710	790	890	980	1070	1180
1" IPS, 2 3/4" x 3 3/4"	1	435	515	590	665	755	835	920	1015
40 Fins (.024)/Ft.	4	465	545	630	710	805	885	980	1080
1 1/4" IPS, 2 3/4" x 3 3/4"	1	410	485	560	630	715	785	870	960
40 Fins (.024)/Ft.	4	435	515	590	665	755	835	920	1015



260 North Elm St., Westfield, MA 01085
(413) 564-5545 Fax: (413) 562-8437

A MESTEK COMPANY

PROJECT: _____ DATE: _____

LOCATION: _____

ARCHITECT: _____

ENGINEER: _____

CONTRACTOR: _____

PO NUMBER: _____

SENIOR

Submittal

High Capacity
Baseboard Radiation

Specification

Furnish and install where shown on all plans/drawings, Sterling Senior Finned Tube Enclosure and Element as described or approved equal of both quality and BTU capacity. Ratings are to be I=B=R approved.

The front panel of the baseboard radiator enclosure, as called out Senior, will be manufactured from 20 gauge pre-painted bonderized C.R.S. The front panel is available in 18 gauge pre-painted bonderized C.R.S. when specified. The backplate will be manufactured from 22 gauge pre-painted bonderized C.R.S. The damper vane is to be die formed steel. All lateral bends are to be roll formed to ensure continuity of all adjoining enclosures and accessories. The enclosure lengths are to be provided in 12 inch increments from 2 feet through 8 feet long. The front panel is to be fully engaged onto mounting brackets engaged with the back panel. Splice plate and damper joiner are to be used where two pieces of enclosure are adjoining each other in a run. These are to be supplied with all 5', 6' and 8' assembly packages.

All accessories will be die formed 20 gauge cold rolled steel and finished with a baked enamel finish. The accessories will overlap the installed enclosure and are to provide adjustment for make-up in the installed runs of enclosure. The accessories will extend to the floor. The accessories are to be enclosure height.

The brackets are to be of a one piece, die formed construction. The material is to be 16 gauge pre-painted bonderized C.R.S. The bracket is to be self locating for vertical positioning at installation. The bottom horizontal leg is to snap into bottom bend of the enclosure and is to support the element where slide shoes are located.

All elements are to be of the mechanically expanded type to ensure that proper fin to tube bonding is maximized. Copper/ Aluminum elements are to be provided with one end mechanically swaged (flared) for proper assembly. Steel/ Steel elements are to be provided with both ends threaded to accept all domestic NPT fittings or cut square and chamfered for field welding.

In the interest of product improvement, we reserve the right to make changes without notice.