

HydroTherm®

MODEL GX SERIES INSTALLATION, OPERATING AND MAINTENANCE MANUAL

Modulating, Direct Vent, Gas-Fired Condensing Boilers
Natural Or Propane
150,000 to 399,000 Btuh Input



see note



WARNING: If the information in this manual is not followed exactly, a fire or explosion may result causing property damage, personal injury or loss of life.

Do not store or use gasoline or other flammable vapors and liquids in the vicinity of this or any other appliance.

WHAT TO DO IF YOU SMELL GAS:

- Do not try to light any appliance.
- Do not touch any electrical switch. Do not use any phone in your building.
- Immediately call your gas supplier from a neighbor's phone. Follow the gas supplier's instructions.
- If you cannot reach your gas supplier, call the fire department.

Installation and service must be performed by a qualified installer, service agency or the gas supplier.

WARNING: Installation and service must be performed by a qualified installer, service agency or the gas supplier in accordance with all local and national codes. Failure to comply with this warning can result in a fire or explosion causing property damage, personal injury or loss of life!

WARNING: It is the responsibility of the homeowner to keep the vent terminal clear of snow and ice. Failure to comply with this warning can result in excessive levels of carbon monoxide causing severe personal injury or death!

INSTALLER: THESE INSTRUCTIONS MUST BE AFFIXED ADJACENT TO THE BOILER.
CONSUMER: RETAIN THESE INSTRUCTIONS FOR FUTURE REFERENCE PURPOSES.

Note: For LP gas use conversion kit: GX82650-1 on GX-150 & 200, GX83017-1 on GX-400

Advanced Thermal Hydronics

IN UNITED STATES: 260 NORTH ELM ST., WESTFIELD, MA 01085 • (413) 564-5515 FAX (413) 568-9613
IN CANADA: 7555 TRANMERE DRIVE, MISSISSAUGA, ONTARIO L5S 1L4 • (905) 672-2991 FAX (905) 672-2883

CONTENTS

Before You Start..... page 2
 Boiler Ratings & Capacities page 2
 Boiler Location page 3
 Clearances to Combustible Construction page 3
 Combustion Air page 4
 General Venting Guidelines page 4
 Horizontal Direct Vent Systems page 5
 Vertical Direct Vent Systems..... page 9
 Condensate Drain page 10
 General Plumbing Guidelines page 11
 Primary Loop Plumbing page 13
 Multiple Boiler Primary Loop Plumbing page 13
 Secondary Loop Plumbing page 13
 Gas Supply Piping page 18
 Electrical Wiring..... page 19
 Sentry 2100 Controller page 26
 Boiler Set Up page 29
 Operating Instructions page 29
 Boiler Checking & Adjusting page 33
 Gas Pressure Adjustment page 33
 Boiler Maintenance page 34
 Wall Hung Conversion page 35
 Trouble Shooting page 36
 Replacement Parts page 41

BEFORE YOU START

WARNING: This manual must be read and fully understood before installing, operation or servicing this boiler! Failure to follow these instructions could result in a fire or explosion causing extensive property damage, personal injury or death!

These instructions cover the GX Series gas fired, direct vent, low pressure, hot water boiler. GX boilers have been design certified by CSA for use with natural and propane gas under the latest edition of ANSI-Z21.13/CSA 4.9, Gas-Fired Low Pressure Steam and Hot Water Boilers.

Each unit has been constructed and hydrostatically tested for a maximum working pressure of **30 psi, 207 kPa**, in accordance with Section IV of the ASME Boiler and Pressure Vessel Code. Each boiler has been equipped with a **30 psi, 207 kPa** pressure relief valve.

This manual covers the application, installation, operation and maintenance of a GX Series low pressure hot water boiler.

To obtain the safe, dependable, efficient operation and long life for which this boiler was designed, these instructions must be read, understood and followed.

Direct all questions to your Hydrotherm distributor or to the Customer Service Department, 260 North Elm Street, Westfield, MA 01085. Always include the model and serial numbers from the rating plate of the boiler in question.

The owner should maintain a record of all service work performed with the date and a description of the work done. Include the name of the service organization for future reference.

Where required by the authority having jurisdiction, the installation must conform to the Standard for Controls and Safety Devices for Automatically Fired Boilers, ANSI/ASME CSD-1.

The installation must conform to the requirements of the authority having jurisdiction or, in the absence of such requirements, to the National Fuel Gas Code, ANSI Z223.1-latest revision. In Canada, the installation must be in accordance with the requirements of CSA B149.1 or B149.2 Installation Code for Gas Burning Appliances and Equipment.

If installed in the Commonwealth of Massachusetts, you **MUST FOLLOW** the additional instructions contained in Hydrotherm’s instruction sheet MA IOM. If you don’t have a copy call your Hydrotherm distributor or Hydrotherm.

BOILER RATINGS & CAPACITIES

Before undertaking the installation of the GX check the boiler rating plate to ensure that the boiler is the proper size for the job.

Also ensure that the boiler has been set up for the type of gas available at the installation site. Other important considerations are the availability of an adequate electrical supply, fresh air for combustion and proximity a suitable outside wall.

High Altitude Operation

The GX boiler is designed to operate to capacity in installations with **2000 ft, 610 m** of elevation or less. At elevations higher than **2000 ft, 610 m** the unit will de-rate due to the lower air density, see Figure 1.

NOTE: It is the *Installers responsibility* to check the combustion, and to adjust the combustion in accordance to Operating Instructions Section.

Figure 1- Input vs Elevation Graph

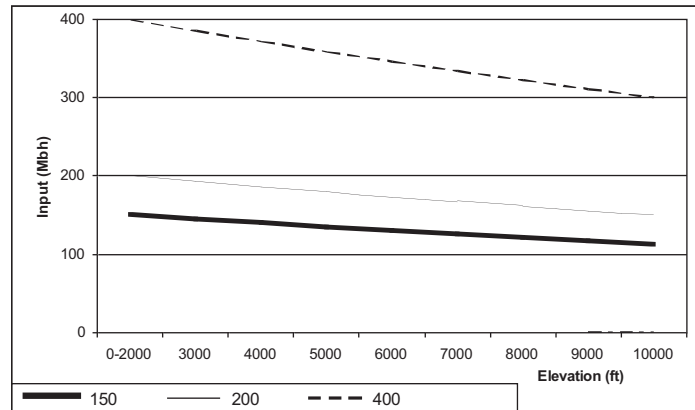

WARNING: At elevations greater than 2000 ft, 660 m, the combustion of the GX must be checked with a calibrated combustion analyzer to ensure safe and reliable operation. Consult the Operating Instructions Section for instructions on adjusting the input to provide proper operation. Failure to comply with this warning can result in excessive levels of carbon monoxide causing severe personal injury or death!

BOILER LOCATION

WARNING: The clearances to combustible construction listed in Table 1 must be maintained. Failure to comply with this warning can result in a extensive property damage, severe personal injury or death!

CAUTION: This boiler is designed to operate only in residential and commercial heating systems. It is not intended for:

1. Outdoor installations, or unheated spaces, which can cause freezing.
2. Process heating of potable water, or any other fluids.
3. Un-pressurized, and gravity feed heating systems.
4. Heating systems with very low pressures or flow.

Improper use or installation will seriously damage the boiler, voiding warranty!

1. Locate the boiler in an area that provides good access to the unit. Keep in mind that servicing may require the removal of jacket panels. Accessibility clearances should take precedence over fire protection clearances. Table 1 lists the minimum clearances for servicing, however **24 in, 610 mm** is recommended.

2. An optimum site will be level, central to the hot water piping system and close to an outside wall.

NOTE: This boiler is designed for direct placement on a combustible floor. Never install this boiler on carpeting!

3. DO NOT install this boiler in a location that would subject any of the gas ignition components to direct contact with water or excessive moisture during operation or servicing. **The boiler location ambient temperature must be no less than 50°F, 10°C including the condensate line.**
4. NEVER store objects on or around the boiler.
5. This boiler may be wall mounted. See the Wall Hung Conversion section listed in the table of contents.

WARNING: Never store combustible materials, gasoline or any product containing flammable vapors or liquids in the vicinity of the boiler. Failure to comply with this warning can result in extensive property damage, severe personal injury or death!

WARNING: Liquefied Petroleum, LP, gas is heavier than air; it is imperative that your boiler is not installed in a pit or similar location that will permit heavier than air gas to collect. Local Codes may require appliances fueled with LP gas be provided with an approved means, of removing unburned gases from the room. Check your local codes for this requirement. Failure to comply with this warning can result in extensive property damage, severe personal injury or death!

Table 1 - Clearances

Surface	Combustible Clearance		Service Clearance	
	in	mm	in	mm
Front	0	0	24	610
Back	0	0	0	0
Sides	0	0	12	305
Top	0	0	12	305
Bottom - 150 & 200	0	0	12	305
Bottom - 400	0	0	0	0
Flue Pipe - enclosed	2	51	n/a	n/a
Flue Pipe - in free air	0	0	n/a	n/a

COMBUSTION AIR

WARNING: This boiler must be supplied with combustion air in accordance with Section 5.3, Air for Combustion & Ventilation, of the latest revision of the National Fuel Gas Code, ANSI Z223.1/NFPA 54 and all applicable local building codes. Failure to provide adequate combustion air for this boiler can result in excessive levels of carbon monoxide which can result in severe personal injury or death!

WARNING: Never operate this boiler unless the air intake is connected to the outdoors. Failure to comply with this warning can result in excessive levels of carbon monoxide causing severe personal injury or death!

WARNING: Each boiler must have it's own intake air system. Common intake air systems are not to be used! Improper installation can result in excessive levels of carbon monoxide which can cause severe personal injury or death!

To operate properly and safely this boiler requires a continuous supply of air for combustion. NEVER store objects around the air inlet!

Use appropriate adapters to increase the 1½ in, 38 mm air inlet collar to 3 in, 76 mm at the boiler, GX-150 & 200, Figure 2. Use a 2 in, 51 mm to 4 in, 102 mm adapter on the GX-400. Terminate the air inlet system per the instructions found in the venting sections that follow.

Figure 2 - Air Inlet System Attachment

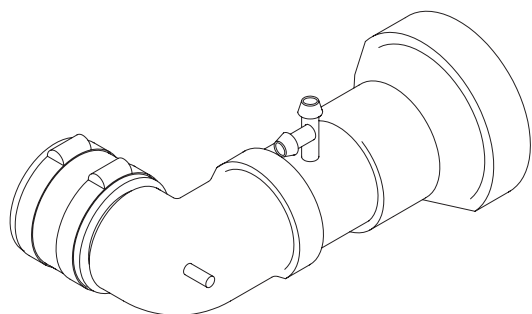

One of the following materials is to be used for the air intake pipe:

- **GX-150 & 200:** 3 in, 76 mm, PVC Sch.40 pipe or Galvanized Steel pipe.
- **GX-400:** 4 in, 102 mm or 6 in 152 mm, PVC Sch.40 pipe or Galvanized Steel pipe.

See Table 2 for the maximum equivalent air intake system length.

CAUTION: Combustion air contaminated with fluorocarbons or other halogenated compounds such as cleaning solvents, refrigerants, chloride, fluoride, bromine or iodine will result in the formation of acids in the combustion chamber. These acids will cause premature failure of the boiler voiding the warranty!

GENERAL VENTING GUIDELINES

WARNING: The vent installation must be in accordance with Part 7, Venting of Equipment, of the latest revision of the National Fuel Gas Code, ANSI Z223.1/NFPA 54 applicable provisions of the local building codes. Improper venting can result in excessive levels of carbon monoxide which can result in severe personal injury or death!

NOTE: Compliance with code requirements doesn't insure a satisfactory installation; good common sense must also be applied.

WARNING: Each boiler must have it's own vent system. Common positive pressure vent systems are not to be used! Improper installation can result in excessive levels of carbon monoxide which can cause severe personal injury or death!

WARNING: Field supplied piping and fittings are required to complete installation. The combustion air and vent pipe and fittings must conform to ANSI and ASTM standard D1785 for schedule 40 PVC, D2665 for PVC-DWV, and D2661 for ABS-DWV. Pipe cement and primer must conform to ASTM standard D2564 for PVC or D2235 for ABS. Improper venting can result in excessive levels of carbon monoxide which can result in severe personal injury or death!

The GX condensing gas boiler is a high efficiency boiler utilizing induced power venting. It is designed to be vented directly to the outdoors using the venting methods and materials detailed in this section. The vent system must be both gas tight and watertight. All horizontal vent piping must be sloped back to the boiler a minimum of **1/4 in/ft, 21mm/m** of vent.

NOTE: Steps must be taken to ensure that condensate does not collect in the venting system or the boiler will not operate properly.

This boiler may be vented using the following materials, but local codes must be followed:

- **GX150 & 200: 3 in, 76 mm**, PVC Sch.40 solid core pipe, CPVC Sch.40 pipe, AL29-4C Flex Stainless Vent or AL29-4C Rigid Stainless Vent.
- **GX-400: 4 in, 102 mm or 6 in, 152 mm**, PVC Sch.40 solid core pipe, CPVC Sch.40 pipe, AL29-4C Flex Stainless Vent or AL29-4C Rigid Stainless Vent.

CAUTION: All vent systems must be fully supported by the building structure. The vent connection and vent piping MUST be perfectly aligned to the boiler connection, Figure 3. It MUST NOT APPLY ANY WEIGHT OR LATERAL FORCE TO THE FLUE BOX or the flue box will be damaged voiding the warranty!

Appropriate adapters must be used to increase the **2 in, 51 mm** vent collar to **3 in, 76 mm** at the boiler, GX-150 & 200, Figure 3. On the GX-400 the **4 in, 102 mm** long 4 inch diameter ABS pipe provided with the boiler must be inserted into the exhaust connection on the top of the boiler and tightened in place with the supplied clamp.

Figure 3- Vent Pipe To Boiler Attachment

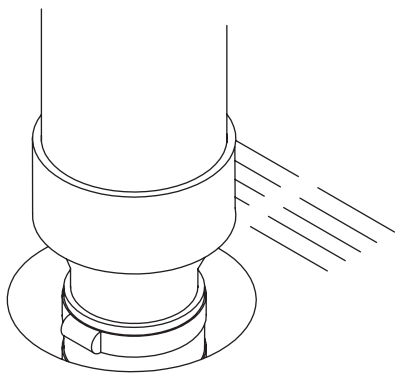

The maximum combined equivalent vent and intake pipe lengths are listed in Table 2. The length specified is the equivalent vent length added to the equivalent intake length.

Table 2 - Vent & Air Intake System Sizing

Model Number	Equivalent Vent & Air Intake System Length (see note)
GX-150	105 ft, 32 m
GX-200	105 ft, 32 m
GX-400	4" - 30 ft, 9 m 6" - 65 ft, 20 m
PGX-150	50 ft, 15 m
PGX-200	50 ft, 15 m
PGX-400	4" - 30 ft, 9 m 6" - 65 ft, 20 m

Note: The lengths listed is for each direction. Subtract 5 ft, 1.5 m, for each 90° elbow except for the vent and air intake elbows. These don't need to be considered. The length of the air inlet system must never exceed the length of the vent system. The vent system length may exceed the air inlet system length by no more than **20 equivalent ft, 6.1 equivalent m**.

HORIZONTAL DIRECT VENT SYSTEMS

Read the information in the GENERAL VENTING GUIDELINES section. It is recommended that two elbows be used, so that the **1/4 in/ft, 21mm/m** slope of the horizontal vent system does not affect the vertical plumb of the pipe connected to the boiler, Figure 4.

Figure 4 - Vent System Attachment

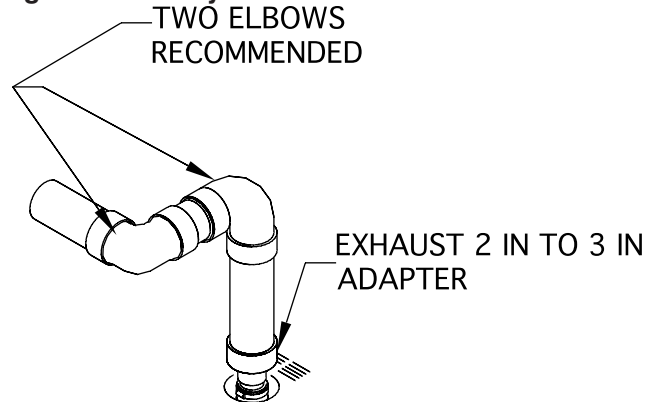

When horizontal vent runs exceed **5 ft, 1.5m**, they must be supported at **3 ft, 0.9 m**, intervals with overhead hangers, **4 ft, 1.2 m** for 6" pipe. The vent system must be pitched down, toward the boiler, **1/4 in/ft, 21mm/m**, of vent. Structural penetrations must be made using approved thimbles.

When penetrating an outside wall the air intake and vent pipes must be constrained as shown in Figure 6. The openings through which the air intake and vent pipes pass must be properly sealed to prevent products of combustion from entering the building.

WARNING: Failure to properly install and seal the air intake and vent system can result in excessive levels of carbon monoxide which can cause severe personal injury or death!

Figure 6 - Wall Penetration Detail

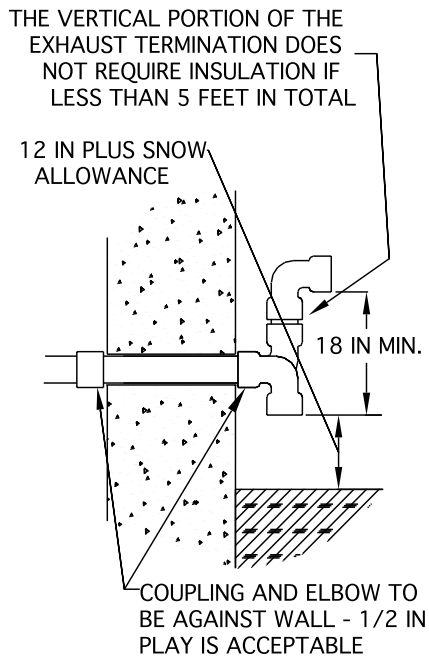

In some cases it may be necessary to attach the air intake and vent pipes to the outside wall for added rigidity, Figure 7. If this is the case, special bracket GX-82075 must be ordered for each pipe. Proper clearances must be maintained.

Figure 7 - Air Intake & Vent Pipe Attachment

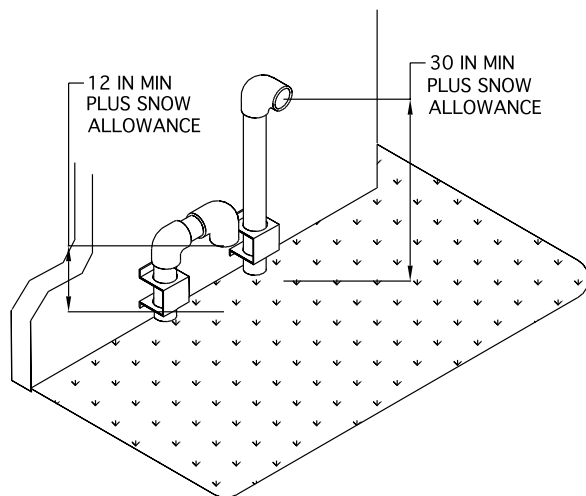

For installations that have to exit the foundation below grade excavate the site as shown in Figure 8 to a point below where the pipes exit the building. Maintain the proper vent clearances as outlined above. Attach the vent and air intake pipes to the outside of the building using special bracket 82075. Ensure that the wall penetrations are properly sealed before backfilling the site.

Figure 8 - Below Grade Installation

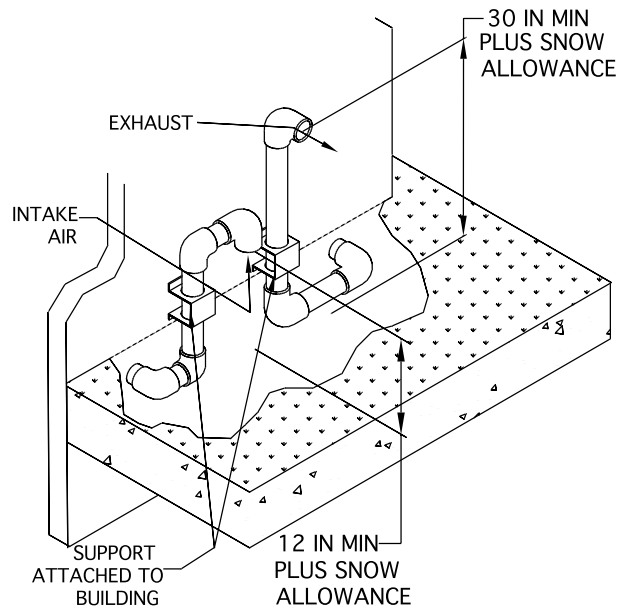

If required, the air intake and vent systems may be run along an outside wall, Figure 9, providing the following conditions are met:

1. The maximum length on the outside of the building is not more than **20 ft, 6.1 m**.
2. All normal termination clearances are maintained.
3. The entire vent system external to the building is insulated using closed cell foamed polyolefin tubing having a minimum wall thickness of **1/2 in, 13 mm**.
4. The air intake and vent systems are supported every **24 in, 610 mm**.
5. The air intake and vent systems are sloped **1/4 in/ft, 21mm/m** back toward the boiler.

Figure 9 - External Air Intake and Vent Systems

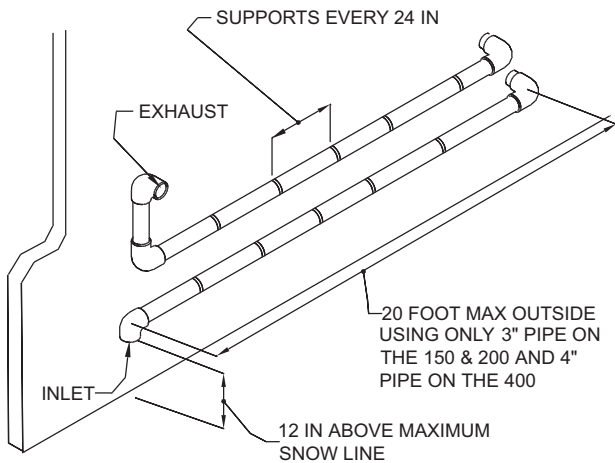

The debris screens provided with the boiler must be installed in both the air intake and vent terminals. Install the screens in the outer most opening then glue a **1 in, 25 mm** length of pipe into the opening to retain them, Figure 10.

Figure 10 - Debris Screen Installation

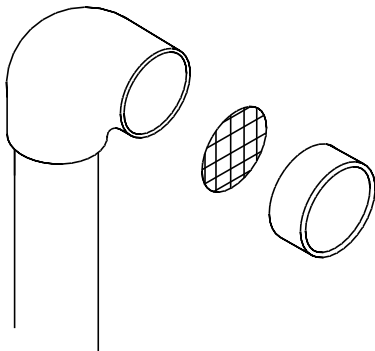

**Concentric Air Intake and Vent Terminal
GX-150 & 200 Only**

If a concentric terminal is used it must be Hydrotherm part number GX-82666 or York part number 1CT0303. The concentric terminal must be located at least **12 in, 305 mm**, above the normal snow line, Figure 11. Position the air intake pipe on the top or to the side to prevent rain from entering the boiler, Figure 13.

When terminals from multiple boiler installations exit a common wall the following conditions must apply:

1. If limited to two terminals the horizontal centerline distance must be **4 in, 102 mm**, or greater than **24 in, 610 mm**, to prevent flue gas recirculation. For more than two terminals located along a horizontal plane, the centerline distance between them must be **24 in, 610 mm**, Figure 11.
2. If the terminals are located in a vertical plane the centerline distance between them must be at least **48 in, 1220 mm**, Figure 12.

Figure 11- Horizontal Concentric Terminal Location

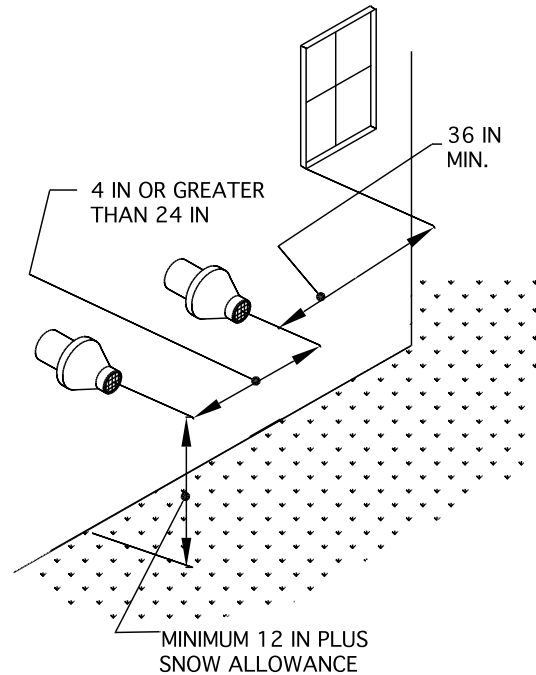
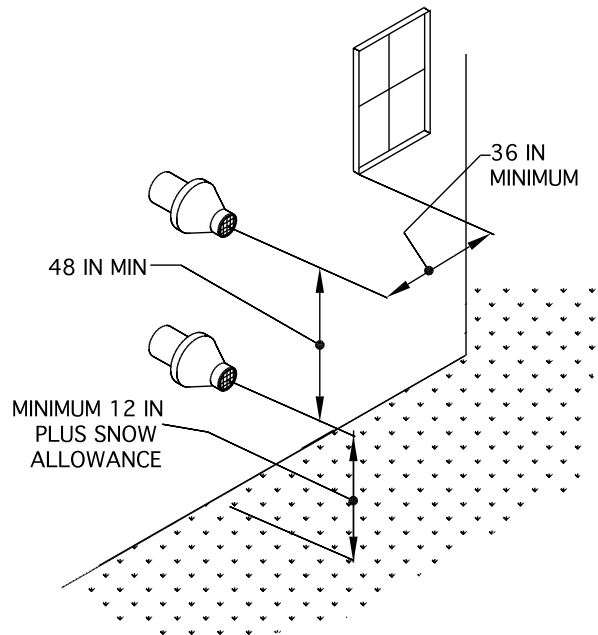
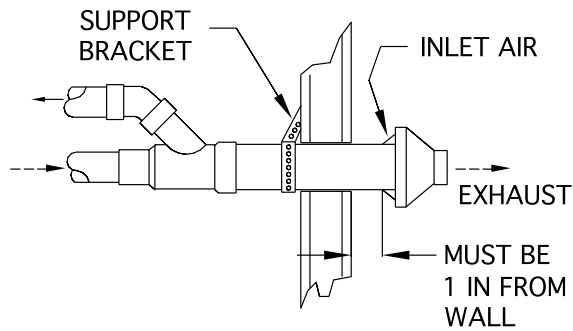

Figure 12 - Vertical Concentric Terminal Location



When penetrating an outside wall the concentric terminal must be constrained as shown in Figure 13. The opening through which the concentric terminal passes must be properly sealed to prevent products of combustion from entering the building. **The air intake of the boiler must be connected to the terminal!**

WARNING: Failure to properly install and seal the concentric terminal can result in excessive levels of carbon monoxide which can cause severe personal injury or death!

Figure 13 - Wall Penetration Detail

The debris screen provided with the boiler must be installed in the concentric terminal as shown in Figure 14.

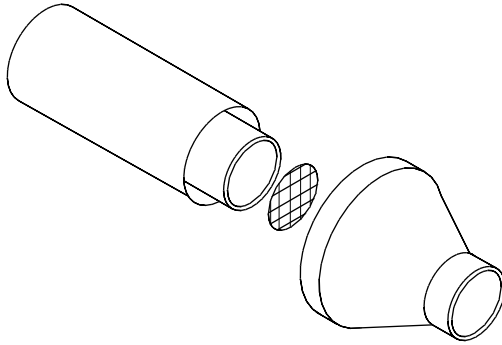
Figure 14 - Debris Screen Installation

VERTICAL DIRECT VENT SYSTEMS

Read the information in the GENERAL VENTING GUIDELINES section before proceeding.

The GX can be vented vertically directly through the building's roof or through a dormant chimney used as a chase, Figures 15 & 16. All roof penetrations must be properly flashed and sealed.

WARNING: Under no conditions, shall this boiler vent gases directly into a masonry chimney nor can an active chimney be used as a chase. Failure to comply with this warning can result in excessive levels of carbon monoxide which can cause severe personal injury or death!

Separate Air Intake and Vent Terminals

The discharge of the vent terminal must point away from the pitch of the roof. The vent terminal must be a minimum of **18 in, 457 mm**, above the air inlet terminal. The vent terminal must also be **24 in, 610 mm**, above any roof surface within a horizontal distance of **10 ft, 3 m**. The air inlet terminal must always be a minimum of **12 in, 305 mm**, plus the snow allowance above any surface that will support snow, however a snow allowance of **24 in, 610 mm**, is highly recommended Figures 15 & 16.

Consult your weather office for the maximum typical snowfall for your region. For example, in Boston MA the maximum typical snowfall is **12 in, 305 mm**. Therefore the inlet must be **24 in, 610 mm**, above any surface that will support snow. The exhaust must be **42 in, 1067 mm**, above this surface.

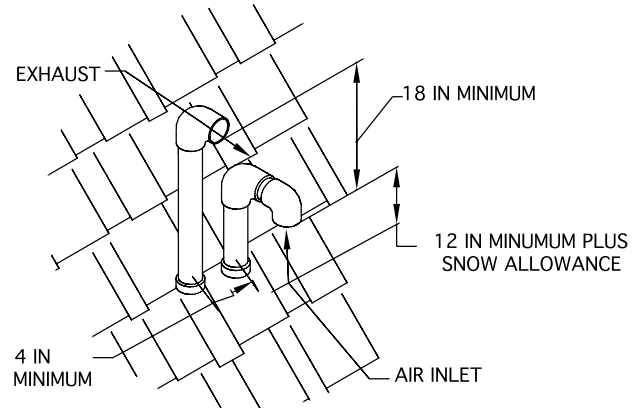
Figure 15 - Two Pipe Through the Roof

The horizontal centerline distance between the inlet and exhaust terminals must be a minimum of **4 in, 102 mm**. If the horizontal distance between the inlet and exhaust is more than **12 in, 305 mm**, increase the vertical separation by the same amount. For example, if the horizontal separation is **24 in, 610 mm**, a minimum vertical separation of **30 in, 762 mm**, is required, **18 in, 457 mm, + 12 in, 305 mm, = 30 in, 762 mm**. If the horizontal distance is greater than **6 ft, 1.8 m** no additional vertical spacing is required. The vertical separation is never required to be greater than **36 in, 914 mm**.

A dormant chimney can be used as a chase through which the air intake and vent pipes can be run, Figure 16. The chimney must not be connected to a fireplace, water heater or any other heating appliance.

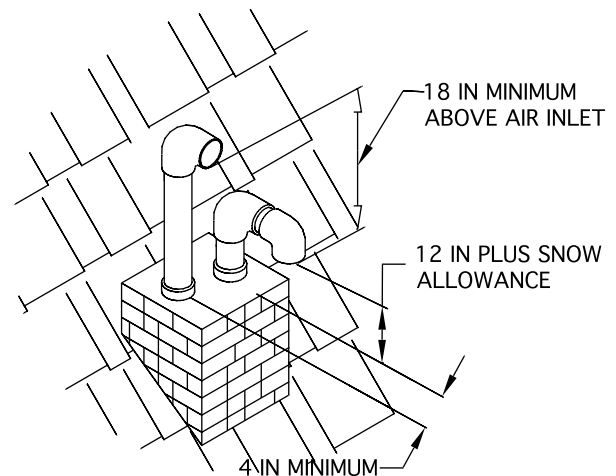
Figure 16 - Two Pipe Using Dormant Chimney

Install and seal a rain cap over the dormant chimney opening to prevent water from entering the building. Use only ABS, PVC^{sch.40}, CPVC, or AL294C pipe for the air inlet and vent systems as stated previously. Ensure that the air inlet and vent system lengths are within the maximums specified in Table 2.

The debris screens provided with the boiler must be installed in both the air intake and vent terminals. Install the screens in the outer most opening then glue a **1 in, 25 mm**, length of pipe into the opening to retain them, Figure 9.

**Concentric Air Intake and Vent Terminal
GX-150 & 200 Only**

If a concentric terminal is used it must be Hydrotherm part number GX-82666 or York part number 1CT0303. The concentric terminal must be located at least **24 in, 610 mm**, above the normal snow line, Figure 17. The building structure must support the air inlet and vent systems. All roof penetrations must be properly flashed and sealed. A dormant chimney can be used as a chase through which the air intake and vent pipes can be run. All previous instructions and warnings apply.

When terminals from multiple boiler installations exit a roof the following conditions must apply:

If limited to two terminals the horizontal centerline distance must be **4 in, 102 mm** or greater than **24 in, 610 mm**, to prevent flue gas recirculation. For more than two terminals located along a given plane, the centerline distance between them must be **24 in, 610 mm**, Figure 18.

Figure 17 - Concentric Through the Roof

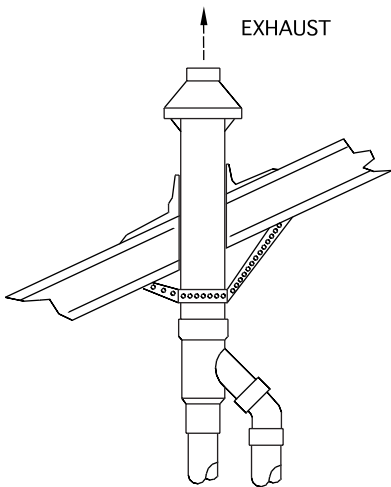
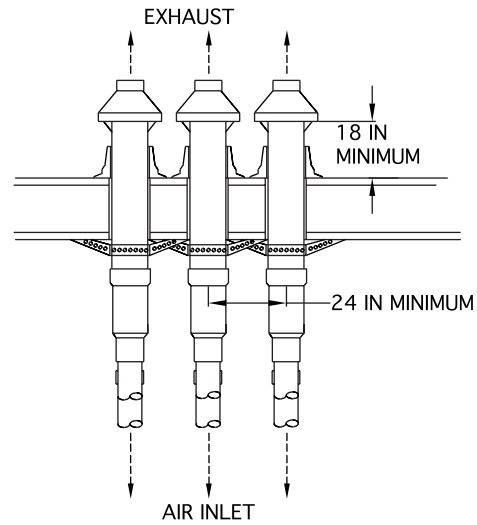

Figure 18 - Multiple Concentric Through the Roof



CONDENSATE DRAIN

WARNING: The condensate siphon must be connected to the boiler per the following instructions or combustion gases will enter the room. This can result in excessive levels of carbon monoxide which can cause severe personal injury or death!

This unit produces water as a byproduct of combustion. Much of this water condenses on the heat exchanger and in the venting system. Condensate must be drained from the boiler into a household drain as shown in Figure 19.

Figure 19 - Condensate Piping

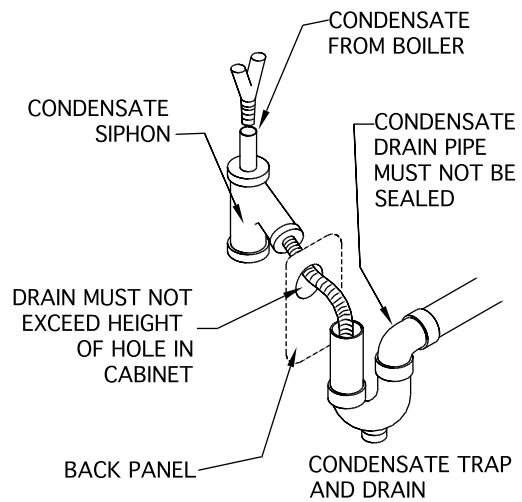

NOTE: Check with your municipality, or local gas company to determine if disposal of untreated combustion condensate is permitted. If not, the condensate will have to be neutralized with lime crystals, marble chips or phosphate chips.

The following are important rules that must be followed when constructing the condensate system:

1. Connect the condensate trap to the drain using **1/2 in, 13 mm**, silicone, rubber, reinforced nylon, or PEX tubing. **Long runs must be properly pitched and supported to prevent blockage.**
2. Do not use nylon tubing, as it will collapse, blocking drainage. This could damage the boiler.
3. Do not seal the opening between the condensate pipe and the condensate drain pipe, Figure 19. In the event of a blocked drain the opening will allow the condensate to overflow and prevent the boiler from flooding.
4. Never have the drain pipe higher than the hole in the back cabinet, this will flood the boiler.
5. Never allow the drain to freeze or become blocked. This will cause condensate to fill the combustion chamber resulting in a no heat condition and damage to the boiler.
6. **NEVER** use copper, steel, or galvanized piping in the construction of the condensate system.
7. When a condensate pump is used or required, select a pump that is designed for residential furnaces.

GENERAL PLUMBING GUIDELINES

If connecting this boiler to a system containing cast iron radiation, be sure to add a strainer to the system to trap any sediment that may dislodge. Failure to do this could harm the heat exchanger and void the warranty! The use of non-oxygen barrier radiant tubing is acceptable, provided that non-ferrous pipe, valves, and fittings are used throughout the entire hydronic system.

CAUTION: All heating system piping must be installed in accordance with the ANSI/ASME Boiler and Pressure Vessel Code, Section IV. All applicable local codes and ordinances must also be followed. If the boiler is installed above any radiation elements it must be fitted with a low water cutoff device installed above the normal boiler water level!

CAUTION: This boiler must have adequate water flowing through it whenever the burner is on. Failure to do this will damage the unit and void the warranty!

CAUTION: All systems must be flushed to remove sediment, flux, filings and other foreign matter. Use products such as Fernox “Superfloc” for new installations and CHR “Central Heating Restorer” for retrofits. Also add an inhibitor to the system water to prevent limestone and magnetite deposits from forming and to protect the boiler from galvanic corrosion. An inhibitor such as CHP, “Central Heating Protector” from Fernox is recommended.

If connecting this boiler to a system containing cast iron radiation, be sure to add a strainer to the system to trap any sediment that may dislodge. Failure to do this could harm the heat exchanger and void the warranty!

The use of non-oxygen barrier radiant tubing is acceptable, provided that non-ferrous pipe, valves, and fittings are used throughout the entire hydronic system. Failure to comply with these instructions will seriously damage the boiler, voiding warranty!

CAUTION: The boiler fittings cannot support any weight. The plumbing system must be supported by the building structure. A wrench must be used to hold the boiler fittings when installing the heating system piping. Failure to do so can seriously damage the boiler, voiding warranty!

The GX hot water boiler comes from the factory ready to be piped to the heating system. The boiler must be used only in a Primary/Secondary pumping system to avoid cycling problems in systems that have poor flow or heating zones with very small capacities.

CAUTION: A 1¼ in, 32 mm, primary loop system must be used for GX-150 & 200 models regardless of the configuration of the secondary system design. A 1½ in, 38 mm, primary loop system must be used for the GX-400. Failure to properly plumb the boiler may void the warranty!

Understand and follow the plumbing requirements provided in this section. Keep serviceability in mind when installing plumbing around the boiler cabinetry. Install fittings that will allow the system to be flushed if needed during annual check-ups. Add an inhibitor to the system water to prevent lime and magnetite deposits from forming, and to protect the boiler from galvanic corrosion. A minimum clearance of **1 in, 25 mm** must be maintained between heating system pipes and all combustible construction. All heating system piping must be supported by suitable hangers not the boiler. The thermal expansion of the system must be considered when supporting the system. A minimum system pressure of **12 psig, 84 kPa** must be maintained.

Hot water boilers are designed to operate with airless water in the system. The GX boiler is provided with a **1/8 in, 3 mm**, air vent located on the top of the unit. This air vent is intended to vent the boiler on initial startup. This device will **NOT** continuously vent air collecting in the primary loop and is not intended to be the primary venting device. The air scoop as shown in Figure 21 is the primary venting location. It is recommended that an additional air scoop be used in the secondary plumbing. If air continues to be a problem an air scrubber must be used.

NOTE: Only inhibited propylene glycol solutions should be used if freeze protection is required. Avoid using mixtures greater than 30%, unless the size of the boilers' circulator(s) is increased accordingly. Under no circumstances should a 50% mixture be exceeded.

Pressure Relief Valve

Each boiler is equipped with a 30 psi pressure relief valve that must be piped in accordance with the ANSI/ASME Boiler and Pressure Vessel Code, Section IV to prevent scalding of persons with hot liquid or vapor in the event of a discharge, see Figure 20.

Support the relief valve discharge piping to prevent strain on the valve body. Leave the open end of the relief valve discharge pipe visible for periodic inspection.

NOTE: The discharge pipe diameter must be the same at the relief valve output diameter. Never restrict the outlet relief valve.

WARNING: Never install any type of valve between the boiler and the relief valve or an explosion causing extensive property damage, severe personal injury or death may occur!

Figure 20 - Relief Valve Piping

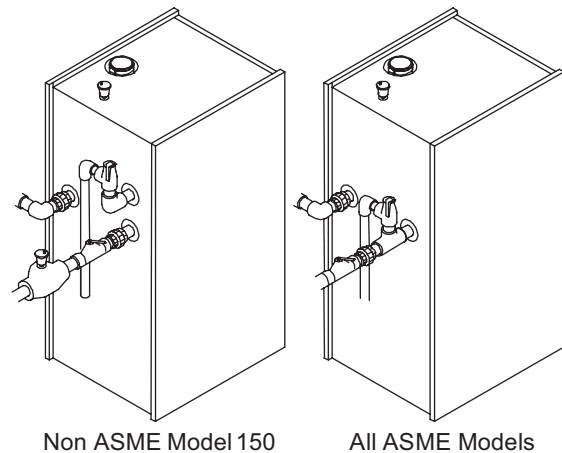

Low Water Cut Off, LWCO

If a LWCO is used ensure that the water line of the “Low Water Cutoff” is at least **6 in, 152 mm**, above the top of the boiler, Figure 21. It is recommended that the LWCO be situated so that it can be tested without removing water from the boiler. Tri-cocks and a gauge glass are highly recommended. Valves shall not be installed between the LWCO and the boiler. Use an air vent if installed as per our diagram to be used as a vacuum breaker and to eliminate air upon filling.

Figure 21 - LWCO & Air Vent Piping

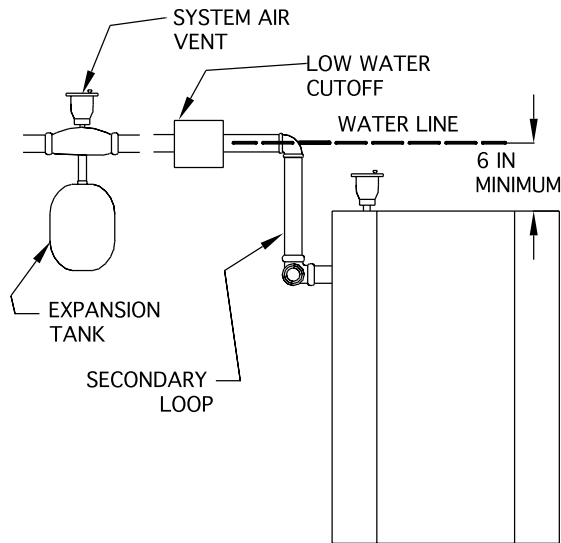

PRIMARY LOOP PLUMBING

This low mass boiler requires a continuous minimum water flow for proper operation. The heat exchanger in this boiler is more restrictive than a conventional boiler. The system pump must be sized to overcome the head loss of the boiler, Figure 22. Greater consideration must be given to the capabilities of the circulating pump(s) in the primary-loop. This includes the pump used for an indirect tank.

Figure 22 - Boiler Head Loss

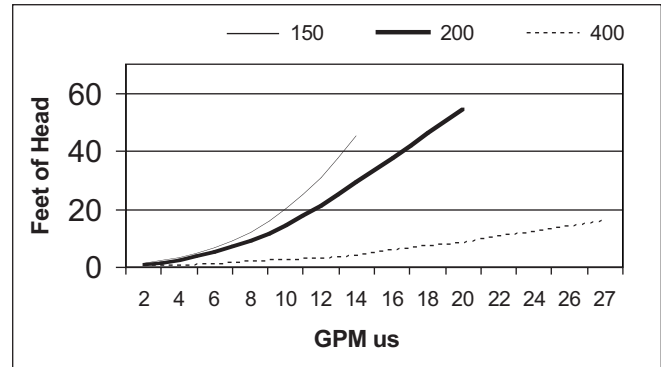

Table 3 lists the recommended circulators for use as the primary and indirect loop pumps.

Figure 23 shows the proper way to plumb a primary loop for single boiler installations.

MULTIPLE BOILER PRIMARY LOOP

Figure 24 shows the proper way to plumb a primary loop for multiple boiler installations.

SECONDARY LOOP PLUMBING

Figures 25 and 26 show some typical primary/ secondary piping systems. It is the responsibility of the installing contractor to determine which system best meets the need of the installation. Contractor modifications to these instructions may be required, based upon the existing piping and system design.

Table 3 - Recommended Primary and Indirect Loop Circulators

Model	Restriction Head Loss	Minimum Flow GPM, L/s	Max. Temp. Rise °F, °C	Minimum Primary & Indirect Pump Size		
				B&G	Grundfos	Taco
GX-150	7 ft at 6 GPM, 2.1 m at 0.4 L/s	6, 0.4	45, 25	NRF-33	UP 26-64	0010
GX-200	10 ft at 8 GPM, 3 m at 0.5 L/s	8, 0.5	45, 25	PL-36	UP 26-99	0011
GX-400	10 ft at 20 GPM, 3 m at 1.25 L/s	13, 0.8	57, 45	PL-36	UP 26-99	0011

Figure 23 - Single Boiler with Indirect Hot Water Heater

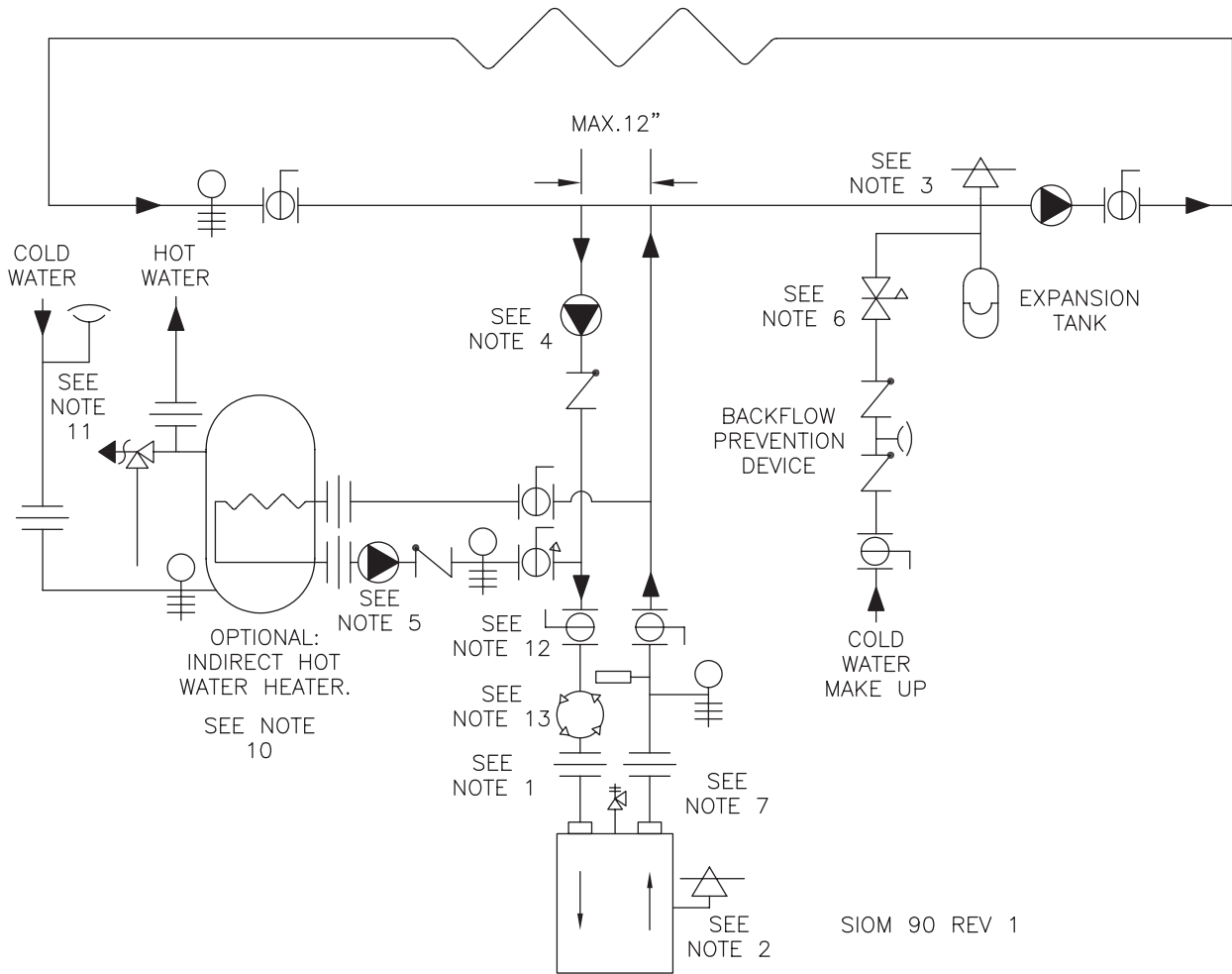

SIOM 90 REV 1

NOTES:

1. All piping and pumps must be supported so that no loads or stresses are applied to boiler heat exchanger. To make boiler service easy use Unions or flexible Vibration Isolation Kit.
2. This boiler is provided with a 1/8" vent that is not intended for continuous system venting.
3. For continuous system venting use a cast iron air scoop, for excessive air conditions use a Spirovent. Do not fire boiler until all air is purged from the system piping. Heat exchanger damage caused by air is not covered by warranty.
4. See Table 3 for boiler pump flow requirements. This pump is wired to terminals C1-L2.
5. See Table 3 for Indirect Water Heater pump flow requirements. This pump is wired to terminals AP-L2.
6. Set pressure reducing valve to 12 PSI.
7. Use 30 psi relief valve max. Locate where discharge will not cause injury or damage. Follow local codes.
8. Add an inhibitor to protect system. (CHP from Fernox)
9. Boiler circuit piping must be sized large enough to handle maximum flow through unit.
10. Suggested piping. When installing an indirect water heater consult manufacturer's manual for full details.
11. Do not install any valves between the Vacuum Relief valve and the tank.
12. Do not operate boiler with service valves closed isolating the boiler from the expansion tank.
13. Failure to follow these instructions will result in heat exchanger damage: All flux and contaminants must be flushed from piping before connecting boiler. Do not connect this boiler to older systems with cast iron radiation without installing a fine particulate separator. TYP: Spirotrap Junior Model TDN 125 FT. Do Not use non-oxygen barrier radiant tubing.

Notice: This drawings show suggested piping configuration and valving. Check with local codes and ordinances for specific requirements.

Pump	Gate Valve	Ball Valve	Pressure Reducing Valve	Check Valve	Pressure Relief Valve	Thermometer	Union	Automatic Air Vent	Heating Load	Drain Valve (Typ.)	Backflow-Prevention Device	Differential Pressure Bypass Valve	Spirotrap Fine Particulate Separator

Figure 24 - Multiple Boiler Installation

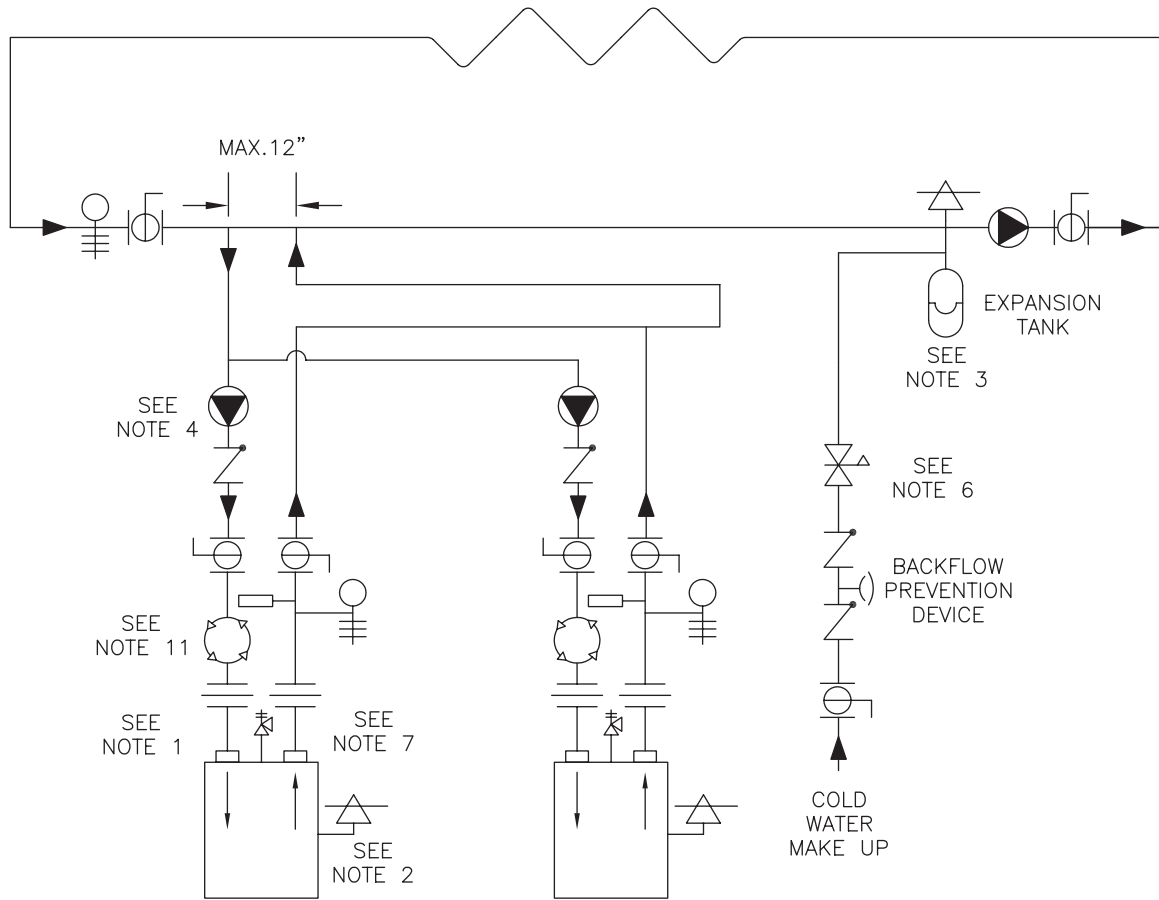

SIOM 91 REV 1

NOTES:

1. All piping and pumps must be supported so that no loads or stresses are applied to boiler heat exchanger. To make boiler service easy use Unions or flexible Vibration Isolation Kit.
2. This boiler is provided with a 1/8" vent that is not intended for continuous system venting.
3. For continuous system venting use a cast iron air scoop, for excessive air conditions use a Spirovent. Do not fire boiler until all air is purged from system piping. Heat exchanger damage caused by air is not covered by warranty.
4. See Table 3 for boiler pump flow requirements. This pump is wired to terminals C1-L2.
5. Indirect Water Heater pump is wired to terminals AP-L2.
6. Set pressure reducing valve to 12 PSI.
7. Use 30 psi relief valve max. Locate where discharge will not cause injury or damage. Follow local codes.
8. Add an inhibitor to protect system. (CHP from Fernox)
9. Boiler circuit piping must be sized large enough to handle maximum flow through unit.
10. Do not operate boiler with service valves closed isolating the boiler from the expansion tank.
11. Failure to follow these instructions will result in heat exchanger damage. All flux and contaminants must be flushed from piping before connecting boiler. Do not connect this boiler to older systems with cast iron radiation without installing a fine particulate separator. TYP: Spirotrap Junior Model TDN 125 FT. Do not use non-oxygen barrier radiant tubing.

Notice: This drawings show suggested piping configuration and valving. Check with local codes and ordinances for specific requirements.

Pump	Gate Valve	Ball Valve	Pressure Reducing Valve	Check Valve	Pressure Relief Valve	Thermometer	Union	Automatic Air Vent	Heating Load	Drain Valve (Typ.)	Backflow-Prevention Device	Differential Pressure Bypass Valve	Spirotrap Fine Particulate Separator

Figure 25 - Multiple Zones Using Circulators

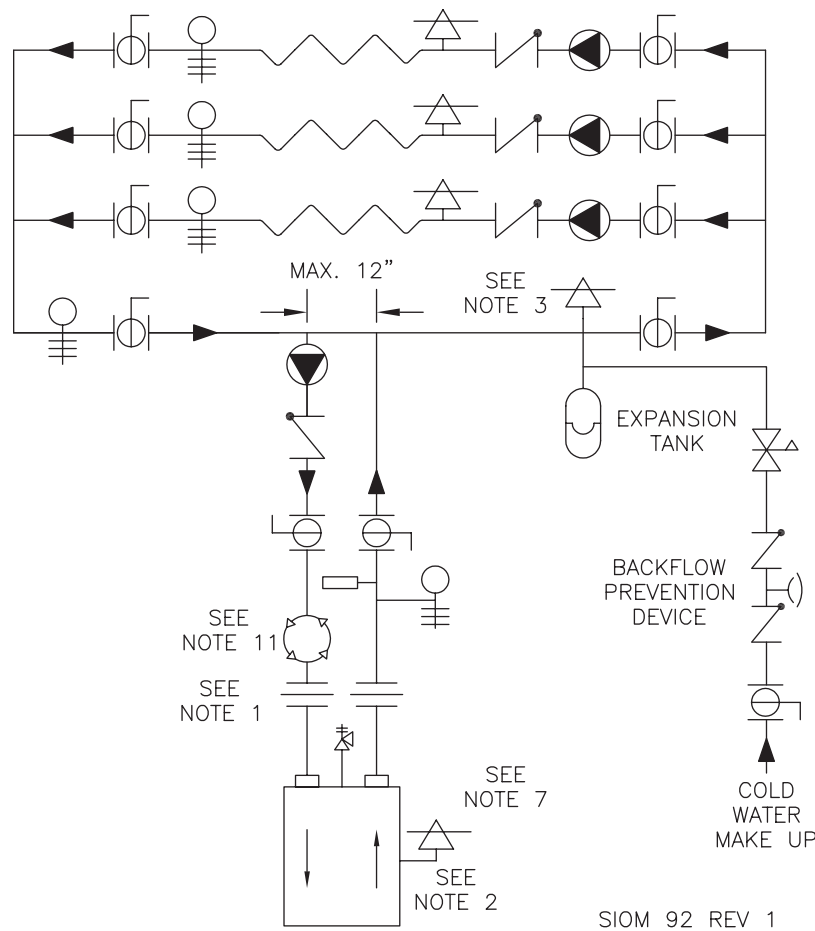

SIOM 92 REV 1

NOTES:

1. All piping and pumps must be supported so that no loads or stresses are applied to boiler heat exchanger. To make boiler service easy use Unions or flexible Vibration Isolation Kit.
2. This boiler is provided with a 1/8" vent that is not intended for continuous system venting.
3. For continuous system venting use a cast iron air scoop, for excessive air conditions use a Spirovent. Do not fire boiler until all air is purged from the system piping. Heat exchanger damage caused by air is not covered by warranty.
4. See Table 3 for boiler pump flow requirements. This pump is wired to terminals C1-L2.
5. Indirect Water Heater pump is wired to terminals AP-L2.
6. Set pressure reducing valve to 12 PSI.
7. Use 30 psi relief valve max. Locate where discharge will not cause injury or damage. Follow local codes.
8. Add an inhibitor to protect system. (CHP from Fernox)
9. Boiler circuit piping must be sized large enough to handle maximum flow through unit.
10. Do not operate boiler with service valves closed isolating the boiler from the expansion tank.
11. Failure to follow these instructions will result in heat exchanger damage: All flux and contaminants must be flushed from piping before connecting boiler. Do not connect this boiler to older systems with cast iron radiation without installing a fine particulate separator. TYP: Spirotrap Junior Model TDN 125 FT. Do Not use non-oxygen barrier radiant tubing.

Notice: This drawings show suggested piping configuration and valving. Check with local codes and ordinances for specific requirements.

Expansion Tank	Pump	Zone Valve	Ball Valve	Check Valve	Automatic Air Vent	Heating Load	Drain Valve (Typ.)	Differential Pressure Bypass Valve	Spirotrap Fine Particulate Separator

Figure 26 - Multiple Zones Valves with Bypass Valve

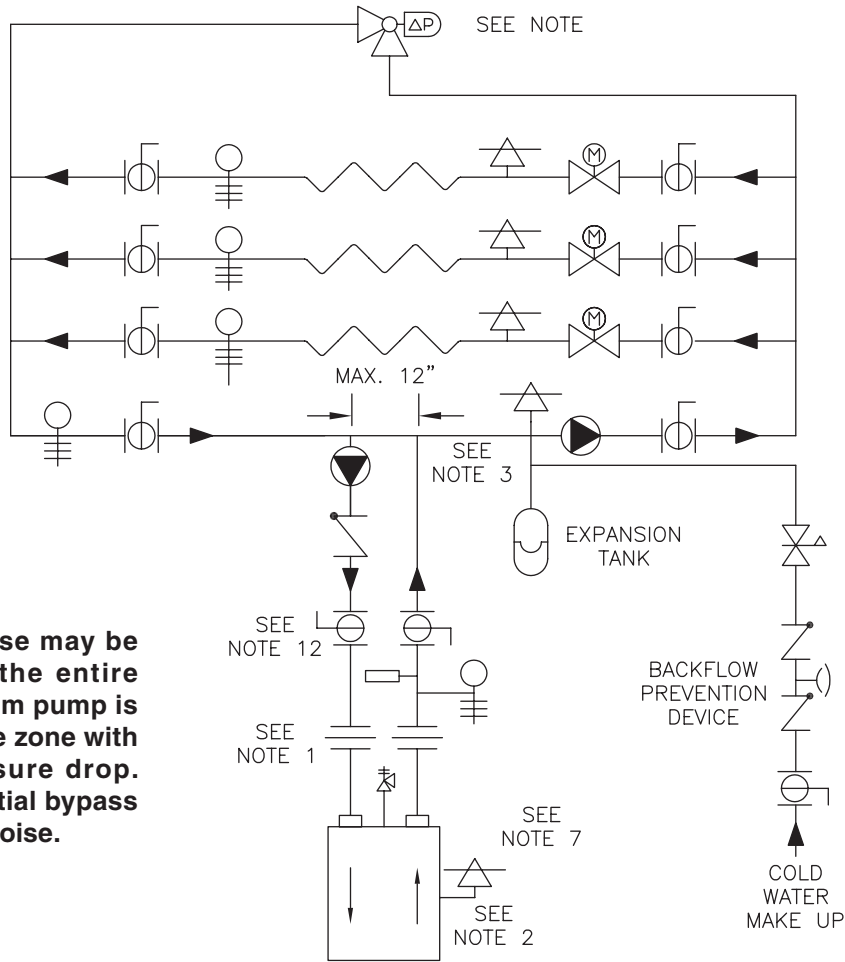











Note: Velocity noise may be a problem when the entire output of the system pump is flowing through the zone with the highest pressure drop. Adjust the differential bypass valve to eliminate noise.

SIOM 93 REV 1

NOTES:

1. All piping and pumps must be supported so that no loads or stresses are applied to boiler heat exchanger. To make boiler service easy use Unions or flexible Vibration Isolation Kit.
2. This boiler is provided with a 1/8" vent that is not intended for continuous system venting.
3. For continuous system venting use a cast iron air scoop, for excessive air conditions use a Spirovent. Do not fire boiler until all air is purged from system piping. Heat exchanger damage caused by air is not covered by warranty.
4. See Table 3 for boiler pump flow requirements. This pump is wired to terminals C1-L2.
5. Indirect Water Heater pump is wired to terminals AP-L2.
6. Set pressure reducing valve to 12 PSI.
7. Use 30 psi relief valve max. Locate where discharge will not cause injury or damage. Follow local codes.
8. Add an inhibitor to protect system. (CHP from Fernox)
9. Boiler circuit piping must be sized large enough to handle maximum flow through unit.
10. Do not operate boiler with service valves closed isolating the boiler from the expansion tank.
11. Failure to follow these instructions will result in heat exchanger damage. All flux and contaminants must be flushed from piping before connecting boiler. Do not connect this boiler to older systems with cast iron radiation without installing a fine particulate separator. TYP: Spirotrap Junior Model TDN 125 FT. Do not use non-oxygen barrier radiant tubing.

Notice: This drawings show suggested piping configuration and valving. Check with local codes and ordinances for specific requirements.

 Expansion Tank	 Pump	 Zone Valve	 Ball Valve	 Check Valve	 Automatic Air Vent	 Heating Load	 Drain Valve (Typ.)	 Differential Pressure Bypass Valve	 Spirotrap Fine Particulate Separator
---	---	---	---	--	---	---	--	---	---

GAS SUPPLY PIPING

The GX hot water boiler comes from the factory ready to be piped to the gas supply. The National Fuel Gas Code, ANSI Z223.1/NFPA 54 and local codes for gas piping requirements and sizing must be followed. If for any reason the boiler is not for the type of gas available at the installation site, call the nearest Hydrotherm distributor to resolve the problem.

Figure 27 depicts the proper way to connect the boiler to the gas supply piping. The manual shut-off valve MUST be installed in the supply piping. It should be approximately **5 ft, 1.5 m**, above the floor. Provide a sediment trap/drip leg at the bottom of the vertical section of the gas supply pipe. A ground joint union should be installed between the boiler gas controls and the supply piping. Each of these items is needed to ensure long life and ease of servicing. Always use a pipe sealant that is suitable for use with LP gas. Flexible gas piping is recommended if accepted by the local codes. Make sure the gas piping doesn't hinder boiler access.

CAUTION: Always use a wrench on the gas valve body when making gas connections to it. Never over-tighten the piping entering the gas valve body or the gas valve will be damaged voiding the warranty!

CAUTION: The gas piping must be properly supported by the building structure and not by the boiler or the gas valve will be damaged voiding the warranty!

Figure 27 - Gas Supply Piping

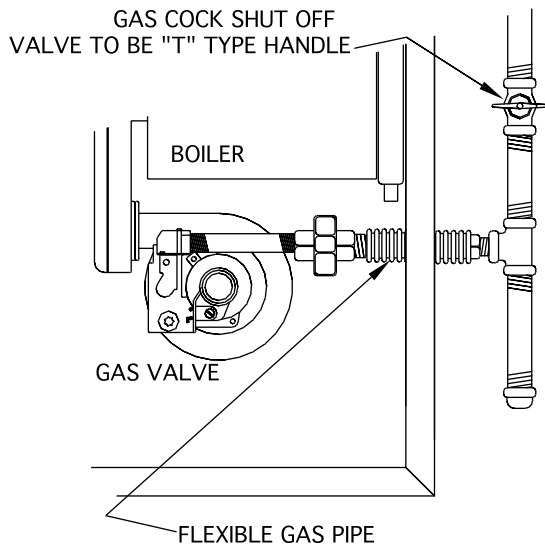

Table 4 should be used to ensure that the gas supply piping is sized properly. If more than one appliance is supplied by the same supply pipe, the piping must be sized based on the maximum possible demand. Do not neglect the pressure drop due to pipe fittings. Table 5 should be used in conjunction with Table 4 to ensure that the gas supply piping is sized properly.

Safe lighting and other performance criteria were met with the gas manifold and control assembly provided on the boiler when the boiler underwent tests specified in ANSI Z21.13/CSA 4.9. All gas connections MUST be leak tested before putting the boiler into operation.

WARNING: Never use an open flame to test for gas leaks. Always use an approved leak detection method. Failure to comply with this WARNING could result in an explosion!

Table 4 - Gas Pipe Capacity

Nominal Iron Pipe Size	Pipe Length								
	10'	20'	30'	40'	50'	60'	80'	100'	150'
3/4"	278	190	152	130	115	105	90	79	64
1"	520	350	285	245	215	195	170	150	120
1 1/4"	1050	730	590	500	440	400	350	305	250
1 1/2"	1600	1100	890	760	670	610	530	460	380

Note: Maximum pipe capacity in ft³/hr is based on a 0.60 specific gravity gas at a pressure of 0.5 psig and a 0.3" WC pressure drop.

Table 5 - Equivalent Pipe Length Chart

Nominal Iron Pipe Size	Type of Pipe Fitting			
	90°	Tee (branch flow)	Gate Valve (full port)	Gas Cocks
3/4"	2.06	4.12	0.48	1.25
1"	2.62	5.24	0.61	1.60
1 1/4"	3.45	6.90	0.81	2.15
1 1/2"	4.02	8.04	0.94	2.50

Whenever the gas supply piping is pressure tested the boiler gas controls must be protected. If the test pressure is equal to, or less than **1/2 psi, 3.5 kPa**, isolate the boiler by closing its manual shut off valve, see Figure 27. If the test pressure is greater than **1/2 psi, 3.5 kPa**, disconnect the boiler and its individual shut-off valve from the gas supply piping.

WARNING: Failure to protect the gas valve from excessive pressure can damage the gas valve which can cause a fire or explosion!

ELECTRICAL WIRING

CAUTION: Label all wires prior to disconnection when servicing controls. Wiring errors can cause improper and dangerous operation!

The electrical connections to this boiler must be made in accordance with all applicable local codes and the latest revision of the National Electrical Code, ANSI/NFPA-70. Install a separate 120 volt 15 amp circuit for the boiler, Figures 28 and 29. A properly rated shut-off switch should be located at the boiler. The boiler must be grounded in accordance with the authority having jurisdiction, or if none, the latest revision of the National Electrical Code, ANSI/NFPA-70. Line voltage field wiring of any controls or other devices must conform to the temperature limitation of type T wire at **95°F, 35°C**, above room temperature. Use copper conductors with a minimum size of #14 awg. Low voltage wiring must not be less than #18 awg with a neoprene, thermoplastic or other equivalent insulation having a minimum insulation thickness of **0.012 in, 3 mm**.

Schematic and ladder diagrams of the boilers wiring are shown in Figures 33 & 34.

CAUTION: The contact capacity of outputs C₁ or A_p is 3 amps with a maximum inrush of 6 amps. If the amp draw of the pumps exceeds these maximums, a pump controller, or isolation relay must be used to prevent damage to the boiler. Damage caused by improper wiring will void the warranty!

Before supplying 120 volts to the boiler, do a continuity check between all the wires and the ground to make sure that there are no electrical shorts that could damage the Sentry 2100 board.

Never use magnetic tip screwdriver near the Sentry 2100.

Verify that the wires connected to the Sentry **TC and AC terminals are not grounded**, or have any voltage applied to them, or voltage to ground - dry contact closure only.

Ensure that the probe wire is not damaged.

CAUTION: Damage to the electrical system components caused by improper wiring will void the warranty!

Thermostat Installation

ALWAYS follow the instructions included with the thermostat to be used to control the boiler. Proper location of the thermostat will ensure efficient trouble-free operation of the boiler. Mount the thermostat to an inside wall at a height approximately five feet above the floor.

Avoid placing the thermostat in areas that will not provide an accurate measurement of the room temperature. Locating the thermostat behind a door, in an alcove, close to a source of thermal radiation or in a drafty area will cause poor or sporadic heating.

Figure 28 - Basic Heating System Wiring

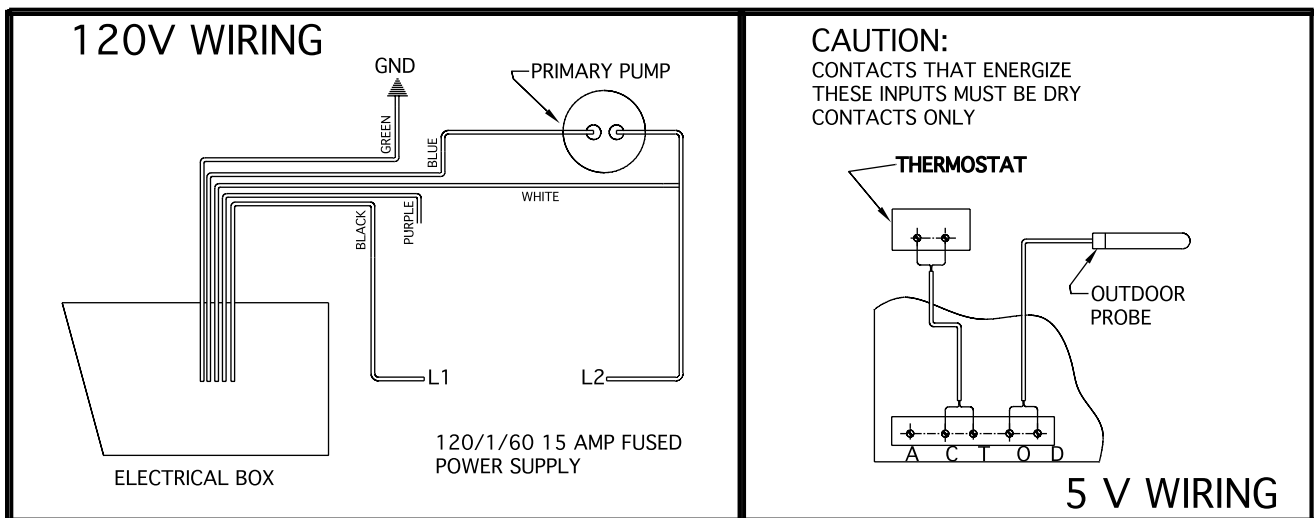
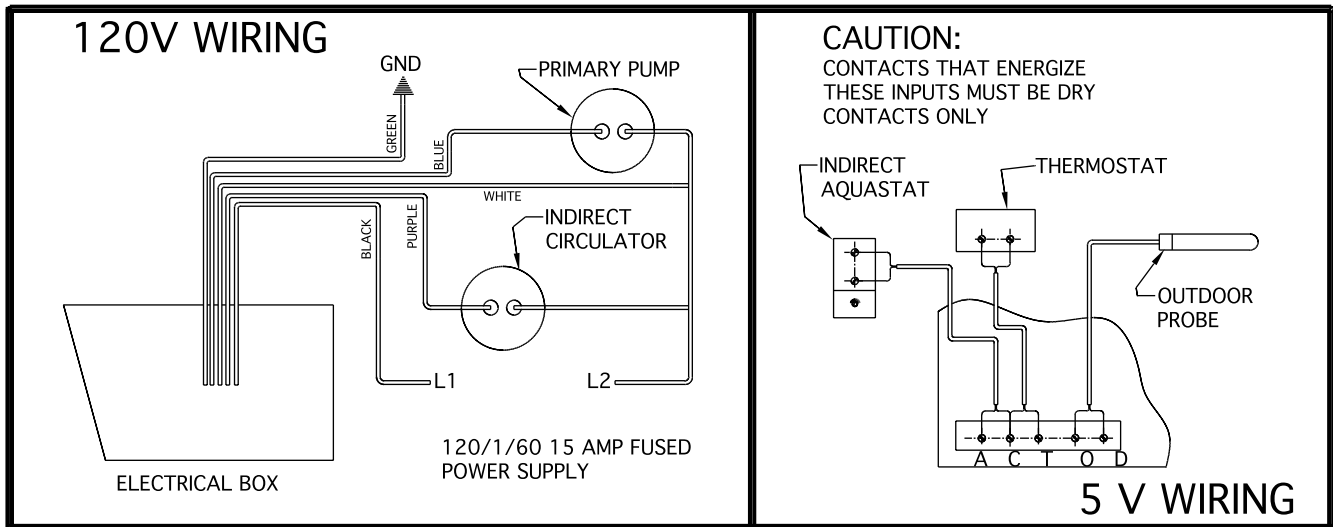

Figure 29 - Basic Heating System and Indirect Tank Wiring



Multiple 4 Wire Zone Valves

Figure 30 shows the basic multiple zoned system uses normally closed four (4) wire zone valves. This wiring system is used with the piping shown in Figure 26.

When there is a call for heat the room thermostat closes the circuit to the zone valve motor, thus opening the zone valve. When the zone valve is opened, the end switch closes the circuit between terminals T and C on the Sentry 2100 control. The Sentry 2100 provides power to the primary and secondary pumps via terminal C₁. Once these pumps are on, the burner fires.

Once the room thermostat is satisfied, it breaks power to the zone valve motor. The end switch opens the circuit between terminals T and C shutting down the pumps and the burner.

**Multiple Zones w/ Taco Valve Controller
Models ZVC403 to ZVC 406**

Figure 31 shows the basic multiple zoned system using normally closed 2, 3 or 4 wire Taco zone valves. This wiring system is used with the piping as shown in Figure 26.

When there is a call for heat the room thermostat closes the circuit between the TT terminals on the Taco zone controller. The controller energizes the appropriate zone valve and closes the circuit between terminals T and C on the Sentry 2100 control. The Sentry 2100 provides power to the primary and secondary pumps via terminal C₁.

Once these pumps are on, the burner fires.

Once the room thermostat is satisfied, it breaks power to the zone valve motor. The end switch opens the circuit between terminals T and C shutting down the pumps and the burner.

Figure 30 - Multiple 4 Wire Zone Valves

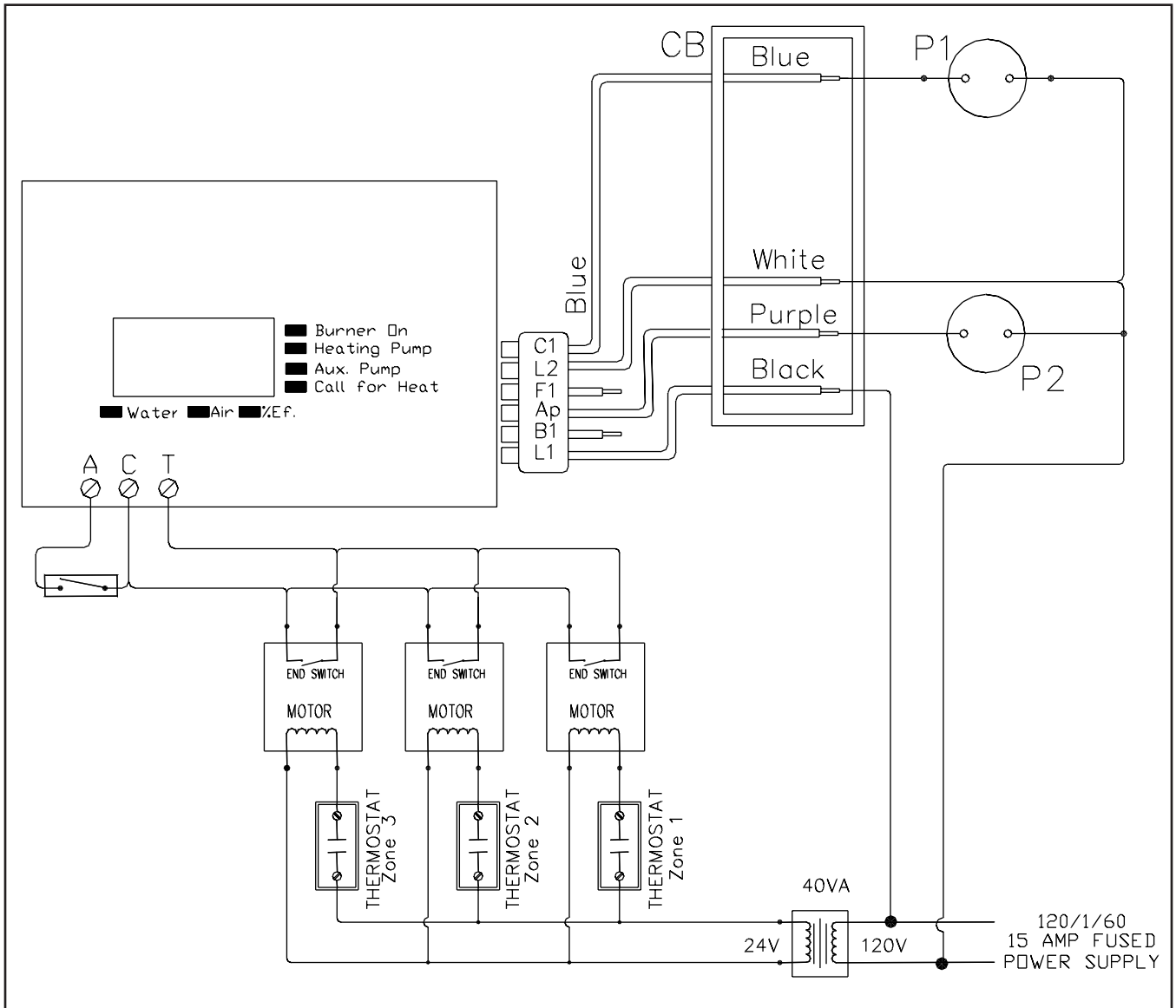
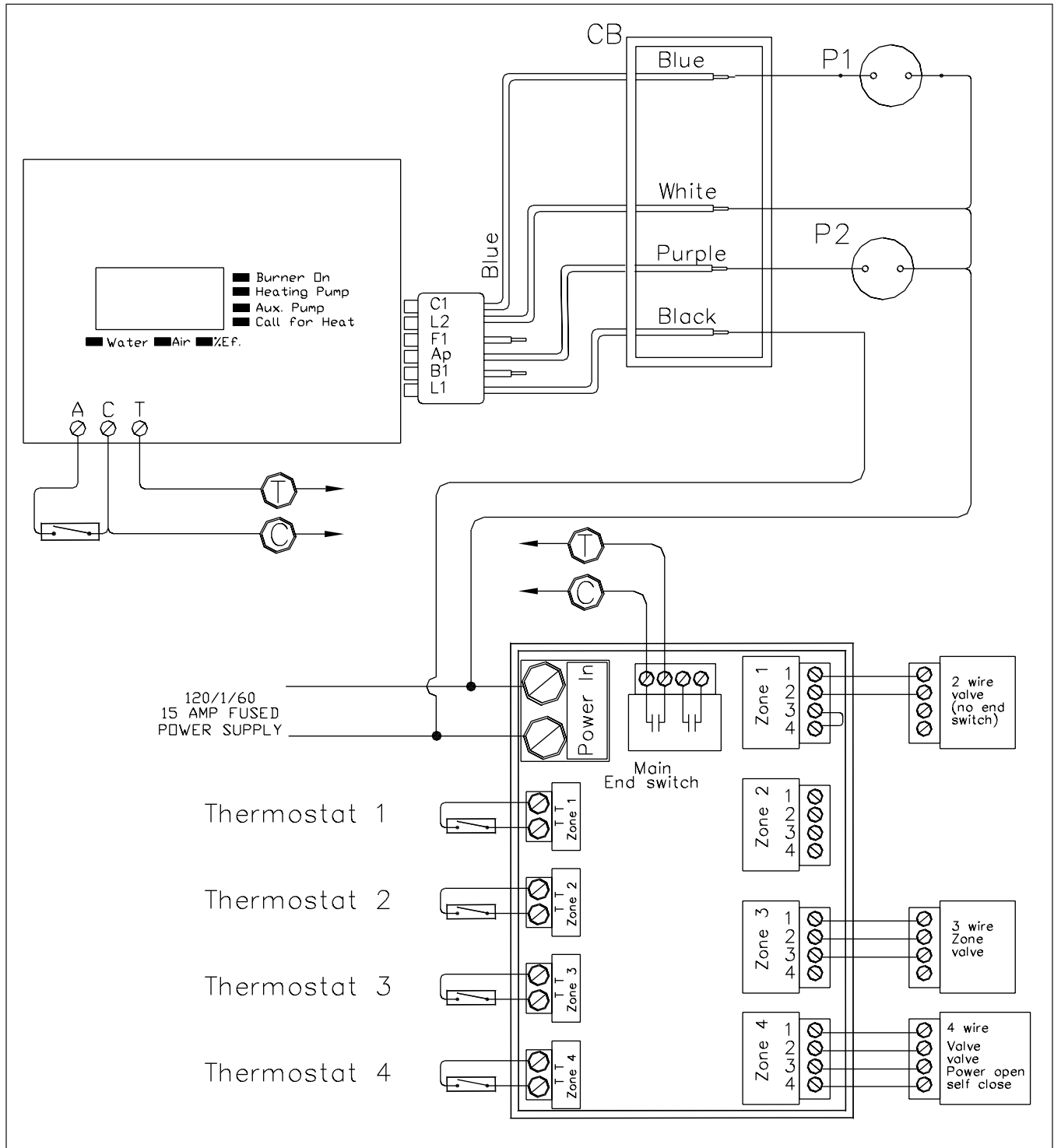

Figure 31 - Multiple Zones w/ Taco Valve Controller, Models ZVC403 to ZVC 406



Multiple Zone Pump Controller
Models Taco SR504, Argo ARM 861 Series

Figure 32 shows the basic multiple zoned system using circulating pumps. This wiring system is used with the piping as shown in Figures 25.

Once the room thermostat is satisfied, it breaks power to the TT terminal of the pump controller de-energizing the XX contacts. The circuit between terminals T and C opens shutting down the pumps and the burner.

When there is a call for heat the room thermostat closes the circuit between the TT terminals on the pump controller. The controller energizes the appropriate circulating pump and closes the circuit between terminals T and C on the Sentry 2100 control. The Sentry 2100, provides power to the primary pump via terminal C1. Once these pumps are on, the burner fires.

Figure 32 - Multiple Zone Pump Controller, Models Taco SR504, Argo ARM 861 Series

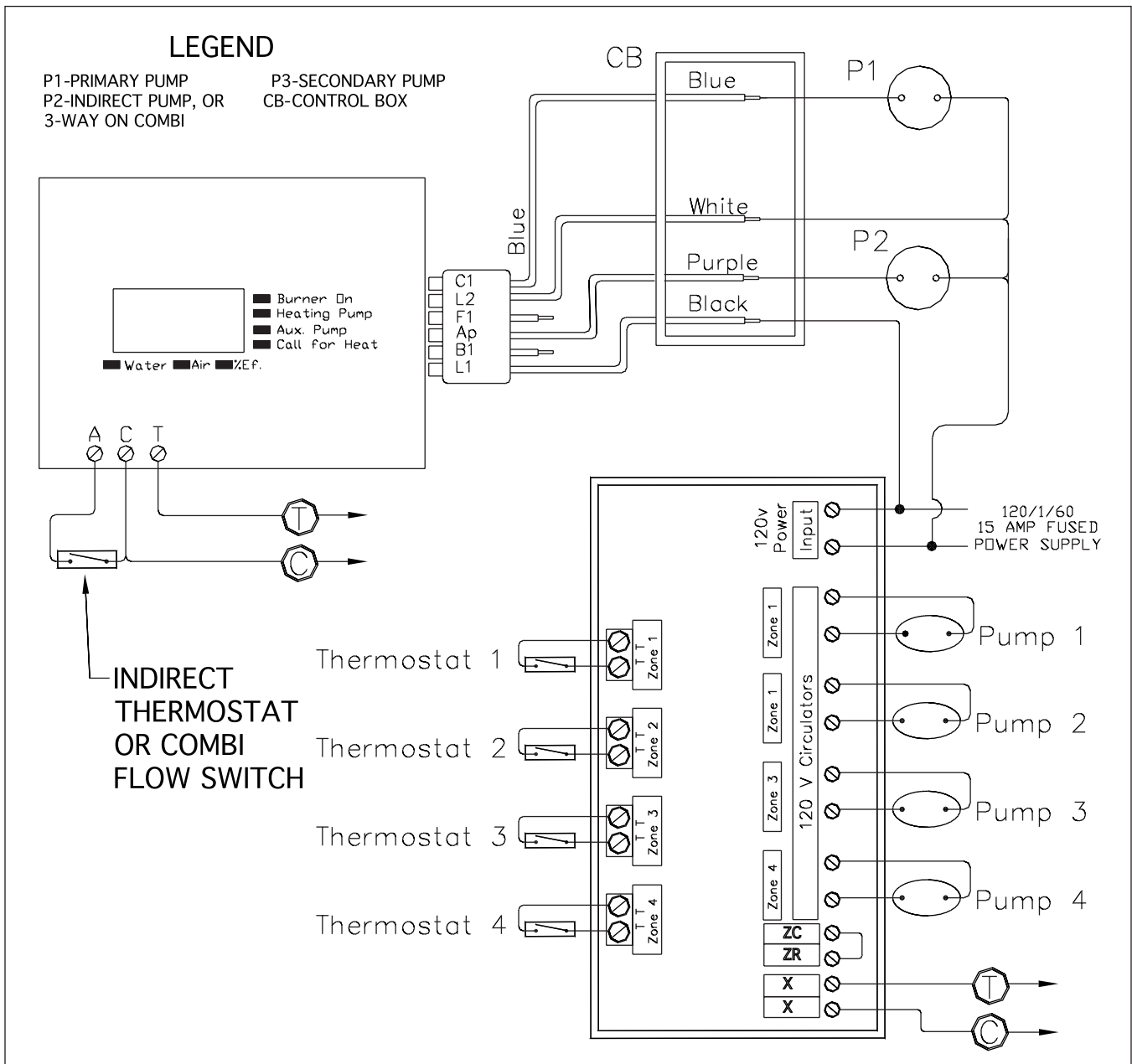

Figure 33 - Boiler Ladder Diagram

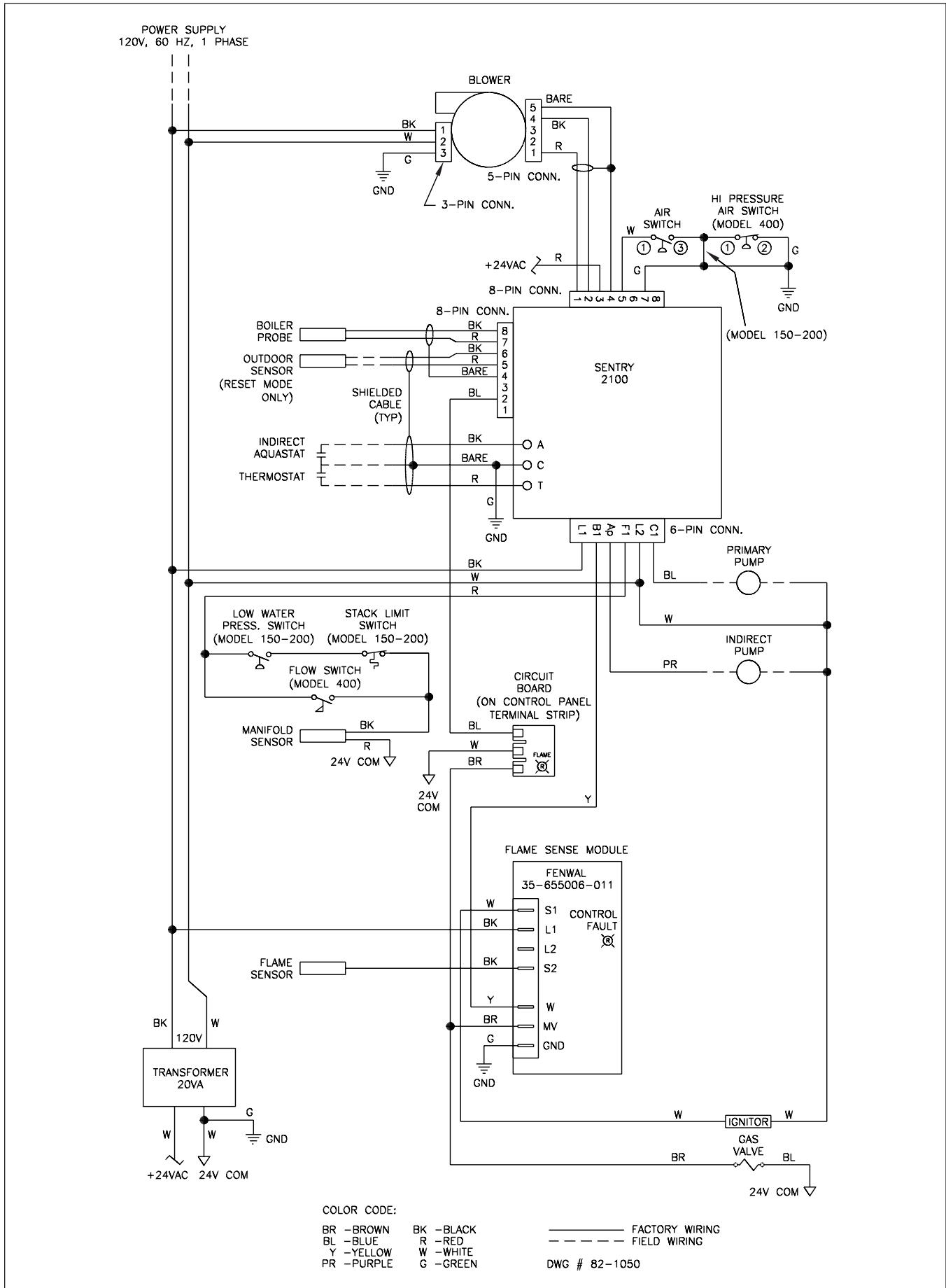
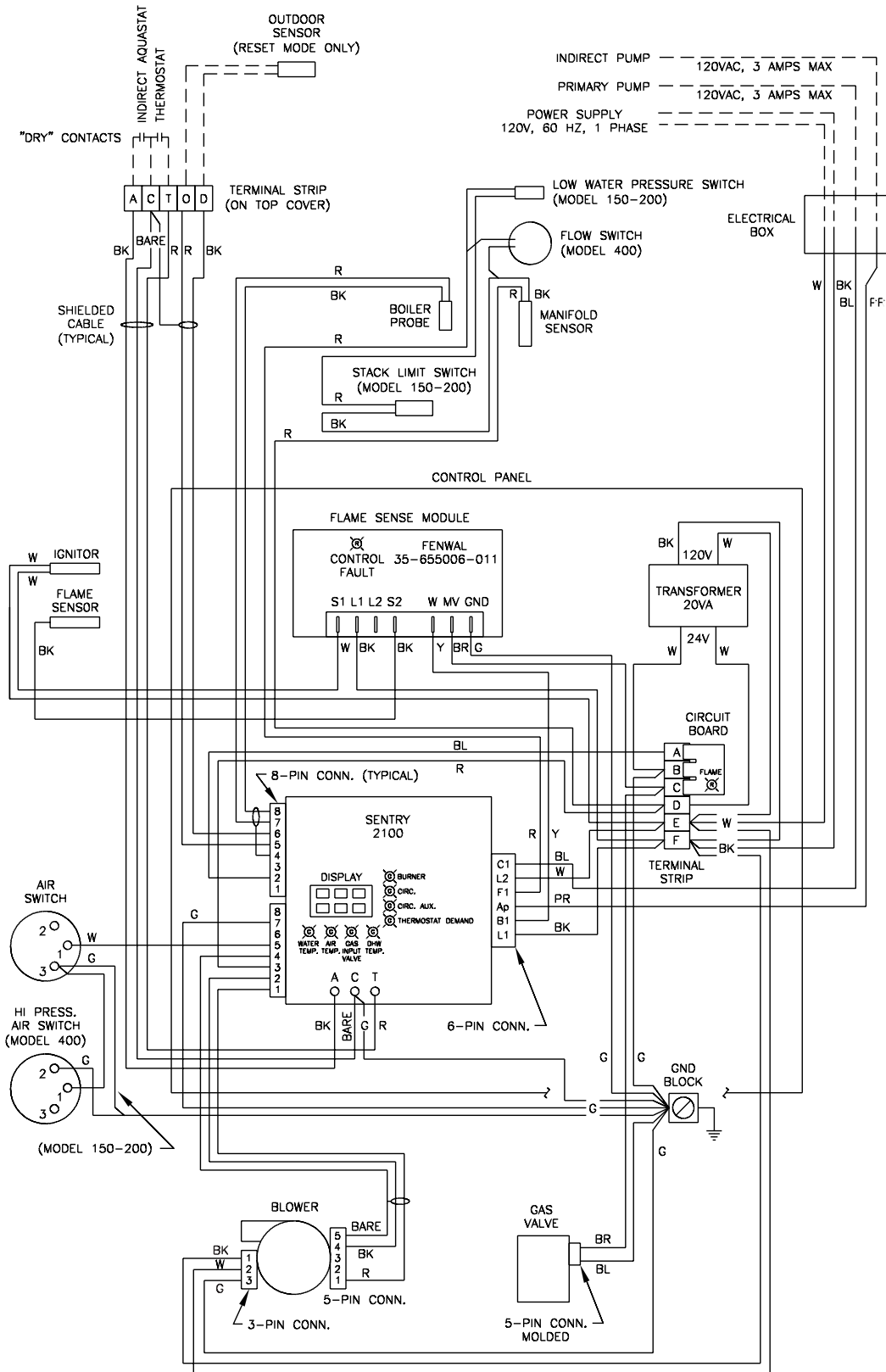

Figure 34 - Boiler Connection Diagram



COLOR CODE:
 BR - BROWN BK - BLACK
 BL - BLUE R - RED
 Y - YELLOW W - WHITE
 PR - PURPLE G - GREEN

————— FACTORY WIRING
 - - - - - FIELD WIRING
 DWG # 82-1050

SENTRY 2100T CONTROLLER

CAUTION: The T4.0 controller can only be used on the GX-400 and the T2.0 on the GX-150 & 200. Misapplication of the controller will result in improper boiler operation.

The Sentry 2100T controller is the central controller for the GX boiler. The Sentry handles all of the combustion logic, along with the energy management functions. The Sentry 2100T operates in two different modes, Conventional or Reset, see Figures 35 & 36. The mode is automatically determined by the presence of the outdoor sensor. When the Sentry 2100T detects the presence of the outdoor sensor the controller will operate in the Reset Mode. If the outdoor sensor is not installed, the controller will operate in the Conventional Mode.

NOTE: If the outdoor sensor is connected after the boiler has been started power to the boiler must be shut off and then turned back on.

Boiler Modulation

The GX boiler employs a pneumatic modulation system. This modulation system increases or decreases the speed of the blower to meet the heating demand. The gas valve pressure regulator senses the air pressure and adjusts the gas flow to ensure correct combustion. The term “Set Point” is used to indicate the desired temperature that the GX will maintain by increasing or decreasing the input.

Indirect Water Heaters

The Sentry 2100 comes with an input and output for a 120-volt indirect pump. When the A and C terminals are closed, dry contact, the boiler will go immediately to indirect domestic mode, whereby the indirect pump is activated, and the boiler will modulate to the LO setpoint.

Sentry Display

The Sentry 2100T contains four green lights that illuminate to indicate the boilers state of operation, Figure 37.

Figure 37 - 2100T Display Screen

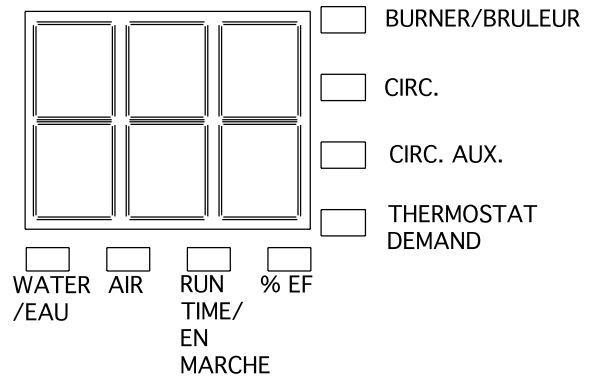

Burner/Bruleur - Indicates that the ignition system is activated.

Circ. - Indicates that the heating pump is energized.

Circ. Aux.- Indicates a call for DHW, and Indirect pump or 3-way valve is activated.

Thermostat Demand - Indicates that terminals T-C are closed, initiating a call for heat.

The LED screen will display one of four values. A light will illuminate above the function to indicate what information is being displayed.

Water Temp - Indicates that the display is showing the boiler water temperature.

Air - if the air sensor is used. When illuminated, indicates that the display is showing outdoor air temperature.

Gas Input Value - Indicates the current input level. Figure 38 must be used to determine the actual input. GX-150 use 46 to 240, GX-200 use 40 to 240 and GX-400 use 35 to 195.

DHW Temp. - indicates that there is a call for domestic hot water.

Figure 35 - Conventional Mode Operation Chart

	T-C & A-C Open	T-C Closed & A-C open	T-C Closed & A-C Closed	T-C Open & A-C Closed
Condition	Standby	Heating Only	Domestic Only	Domestic Only
Set Point	—	HI	LO	LO
Burner On	—	HI - DIF	LO-10	LO-10
Burner Off	—	HI + 10	200°F	200°F
Heat Circ.	Off	On	Off	Off
Aux. Circ.	Off	Off	On	On

Figure 36 - Reset Mode Operation Chart

	T-C & A-C Open	T-C Closed & A-C open	T-C Closed & A-C Closed	T-C Open & A-C Closed
Condition	Standby	Heating Only	Domestic Only	Domestic Only
Set Point	—	HI Calc.	LO	LO
Burner On	—	HI Calc - DIF	LO-10	LO-10
Burner Off	—	HI Calc + 10	200°F	200°F
Heat Circ. (C1)	Off	On	Off	Off
Aux. Circ. (Ap)	Off	Off	On	On

Figure 38 - Input Conversion Chart

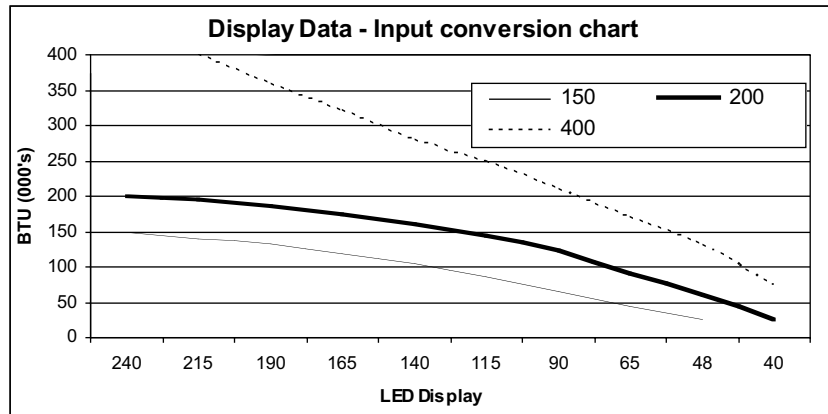

Setting Sentry 2100T control

Programming is accomplished by a series of three push buttons located on the bottom side of the control. To enter the programming mode, press the function key once, "RUN" should be displayed on the screen. To scroll through the various menu options depress ↑. To alter the value of a menu option press "Function" once while the menu option is displayed, and the current value will be displayed, then use ↑ for up, and ↓ for down, until the desired value is obtained. To enter the selected value press "Function", which will return to the menu and store the new setting. When all desired values are set, scroll to the "RUN" menu option, and press Function, which exits the Programming Mode and initiates normal operation. If the control is left in the Program Mode longer than 30 seconds without receiving any input the unit will turn off. Press "Function" once to continue programming or to restart boiler operation.

Below is a list of functions and a description of what they control:

- RUN** - Stores Values & initiates
- LO** - Boiler Setpoint for DHW, **80 - 200°F, 27 - 93°C**
- HI** - Boiler Setpoint for Heating, **80 - 200°F, 27 - 93°C**
- DIF** - Differential, **1 - 40°F, -17°C - 4°C**
- RES** - Sets Outdoor Reset Curve Slope, **70°F, 21°C** to HI
- SFS** - Sets Starting Gas Input Value, 60 to 100
GX150 & 200 is 60 to 100
GX-400 is 45 to 90
- HFS** - Sets Highest Gas Input Value, 100 to 240
GX-150 & 200 is 100 to 240
GX-400 is 90 to 195
- LFS** - Sets Lowest Gas Input Value, 40 to 100
GX-150 & 200 is 40 to 100 (see note)
GX-400 is 35 to 90

NOTE: LFS must not be set below 48 on the GX150 model. To start the control operation return to "RUN" on the menu and press "Function". Normal operation will begin.

Recommended Settings

When programming the Sentry 2100T determine what the hottest boiler temperature required for the coldest day will be. This will be the HI SETTING. If an indirect tank is used for domestic hot water, DHW, determine the minimum boiler temperature required to ensure an adequate supply of hot water. This is the LO SETTING. The LO SETTING is only used during a call for DHW, when A and C terminals are closed. Set the LO to the temperature required for the Indirect Water Heater. **140 °F, 60°C** or at least **30°F, -1°C** higher than the indirect Aquastat is recommend.

WARNING: Proper control settings must be used to prevent water supplied for domestic use from exceeding 130°F, 54°C or a scald injury will occur! When higher water temperatures are required for appliances such as a dishwasher, a mixing valve or some other tempering means must be installed. Households with small children may require water temperatures less than 120°F, 49°C. Local codes must be complied with!

Table 6 - Recommend System Temperatures

System	Hi °F, °C	Dif °F, °C	RES °F, °C
Finned Tube Baseboard	190, 88	20, 11.7	85, 29
Cast Iron Radiators	150, 66	20, 11.7	85, 29
Radiant	130, 54	20, 11.7	85, 29

Outdoor Sensor (10K)

The outdoor sensor should be installed to take advantage of the energy saving features of the Sentry Controller. Install the sensor on the north, or coldest side of the building out of direct sun. It must be at least **10 ft, 3 m** from the vent terminal or other source of heat.

Determining Reset Temperature H_{iCalc}

Once the Sentry 2100T control identifies the presence of a good outdoor sensor, the control will automatically reduce the HI setting based upon the outdoor temperature. For example, if $H_i = 200^\circ\text{F}$, 93°C , $RES = 70^\circ\text{F}$, 21°C and the Air Temperature = 32°F , 0°C , the H_i setpoint, H_{iCalc} , would be calculated as follows:

RESET RATIO

$$= (\text{High Setting} - RES) / RES$$

$$= (200^\circ\text{F}, 93^\circ\text{C} - 70^\circ\text{F}, 21^\circ\text{C}) / 70^\circ\text{F}, 21^\circ\text{C}$$

$$= 1.85$$

RESET TEMPERATURE H_{iCalc}

$$= [(RES - \text{Outdoor Air}) \times \text{Reset Ratio}] + RES$$

$$= [(70^\circ\text{F}, 21^\circ\text{C} - 32^\circ\text{F}, 0^\circ\text{C}) \times 1.85] + 70^\circ\text{F}, 21^\circ\text{C}$$

$$= [70.6^\circ\text{F}, 21^\circ\text{C}] + 70^\circ\text{F}, 21^\circ\text{C}$$

$$= 140.6^\circ\text{F}, 42^\circ\text{C}$$

NOTE: The design temperature is 0°F , -18°C outside air, so at 0°F , -18°C or less, the hi setting is used, and not surpassed.

Figures 39 & 40 are examples of reset temperatures based upon different set points and outdoor air temperatures. The vertical axis is the water temperature that the boiler will maintain and is also the H_i setting of the Sentry 2100T control. The Horizontal axis is the outdoor air temperature.

Figures 39 - Reset Curve For Res = 85°F , 29°C

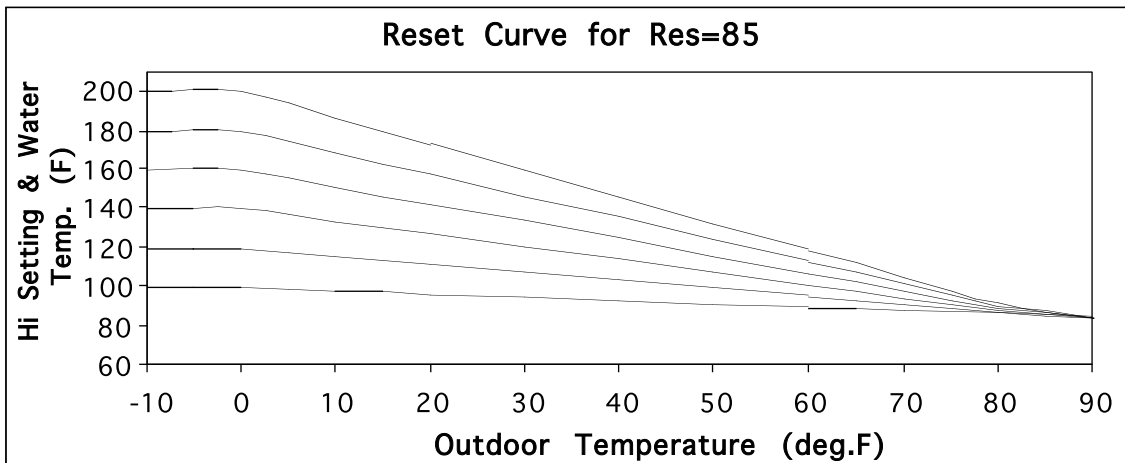

Figures 40 - Reset Curve For Res = 70°F , 21°C

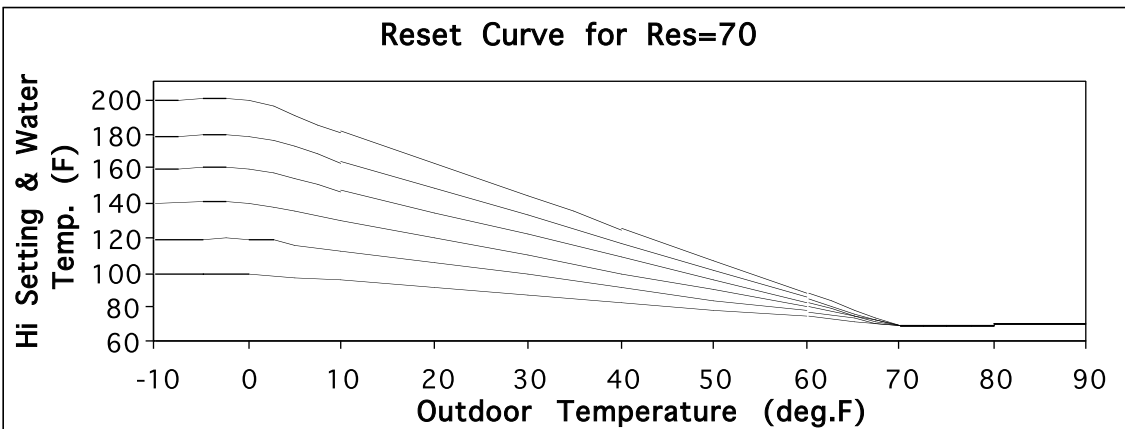

BOILER SET UP

NOTE: Before starting the boiler, turn off the electrical supply going to it. Make sure that gas is available at the gas valve inlet. Open the valves in the hot water return and supply piping. Failure to take these precautions will prevent the boiler from operation properly.

Fill the boiler and all of the radiation with water. Make sure that the system is completely purged of air, see GENERAL PLUMBING GUIDELINES.

Review these instructions and make sure that the boiler installation complies with ALL of the instructions up to this point.

OPERATING INSTRUCTIONS

The GX boiler employs a pneumatic modulation system. This modulation system increases or decreases the speed of the blower to meet the heating demand. The gas valve pressure regulator senses the air pressure and adjusts the gas flow to ensure correct combustion.

WARNING: Before operating read and understand the instructions contained in this manual. Do not attempt to operate this boiler if it has not been installed in accordance with the guidelines set forth in this manual. Read and fully understand the operating instructions in the “For Your Safety Read Before Operating” section of this manual. Failure to comply with this WARNING could result in a fire or explosion causing severe personal injury or death!

Should overheating occur or the gas supply fail to shut off, do not turn off or disconnect the electrical supply to the pump. Instead, shut off the gas supply at a location external to the appliance.

Do not use this appliance if any part has been under water. Immediately call a qualified service technician to inspect the appliance and to replace any part of the control system and any gas control that has been under water.

NOTE: The GX was tested with Natural Gas having a heating value of 1020 BTU per cubic foot. For areas with lower heating values, a combustion test is required to obtain optimum operation.

WARNING: The input Screw MUST NEVER BE ADJUSTED without verifying proper combustion with a calibrated combustion analyzer. Failure to comply with this warning can result in excessive levels of carbon monoxide which can cause severe personal injury or death!

Table 7 contains the range for the CO, CO₂ and NO_x that should be in a flue gas sample of a properly operating boiler at maximum input.

Table 7 - Normal Flue Gas Composition

	Natural Gas	Propane
Carbon Dioxide CO ₂ %	8-9.5	9-10.5
Carbon Monoxide CO ppm	25-175	25-175
NO _x ppm	10-50	10-50

Note: At maximum fan speed of 240 on the Sentry display

The gas supply pressure to the boiler while running at maximum rate must be between **4 to 9 in, 102 to 229 mm, W.C.** for natural gas installations; **9 to 12 in, 229 to 305 mm, W.C.** for propane installations. This pressure can be measured on the gas valve using a manometer, Figure 41 or 42. Ensure that the regulator is capable of maintaining this pressure under all operating conditions. The gas valve is also equipped with a manifold pressure port, Figure 41 or 42.

Figure 41 - Gas Valve Layout, GX-150 & 200

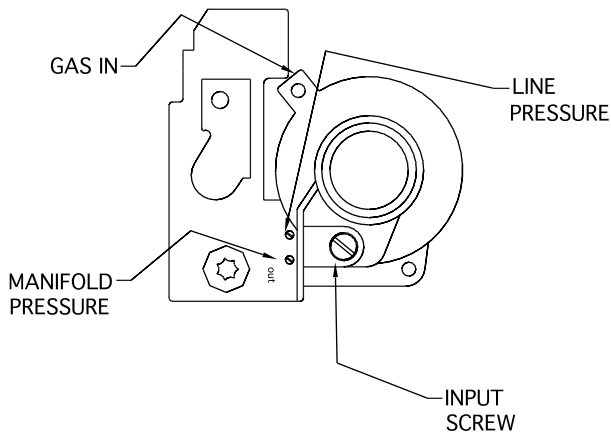
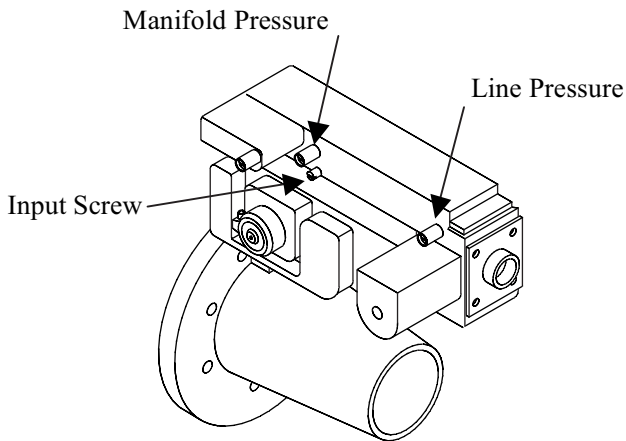

Figure 42 - Gas Valve Layout, GX-400



Ignition System

- A. Connect a manometer to the line pressure port shown in Figure 41 or 42. Make sure that the gas supply piping has been purged of air and that all gas joints up to the gas valve have been thoroughly checked for leaks. Wait at least five minutes for any gas to dissipate before turning on the electrical power.
- B. Read, understand and follow the operating instructions below.
- C. Raise the thermostat at least 5 degrees above the room temperature. The boiler should enter the pre-purge mode before energizing the silicon carbide igniter. Once the igniter is hot, the main gas valve will open and the burner should light. If the burner fails to light the system will make three more ignition attempts. If the burner has not lit after the last ignition try, the gas valve will close and the system will go into lock out. **DO NOT** attempt to reset the system until the ignition system has been inspected and the problem resolved. Once the problem has been resolved and 5 minutes have passed since the last ignition attempt, reset the system by turning the thermostat to it's lowest setting and then back to where it was or by momentarily interrupting the electrical power to the boiler.
- D. With the burner in operation close the manual shutoff valve in the gas supply line. As soon as the burner flame goes out, open the manual shutoff valve. A normal ignition sequence should take place.
- E. With the burner in operation, interrupt the power to the control circuit by lowering and raising the thermostat. A normal ignition sequence should follow.
- F. To test the ignition safety shutoff device, close the manual shutoff valve in the gas supply line. Within 6 seconds of main burner flame extinction, the main gas valve solenoid should close with an audible noise. The igniter should glow and make three attempts at ignition. After unsuccessfully attempting to light the burner the ignition module should lock out.

Figure 43 - Operational Flow Chart

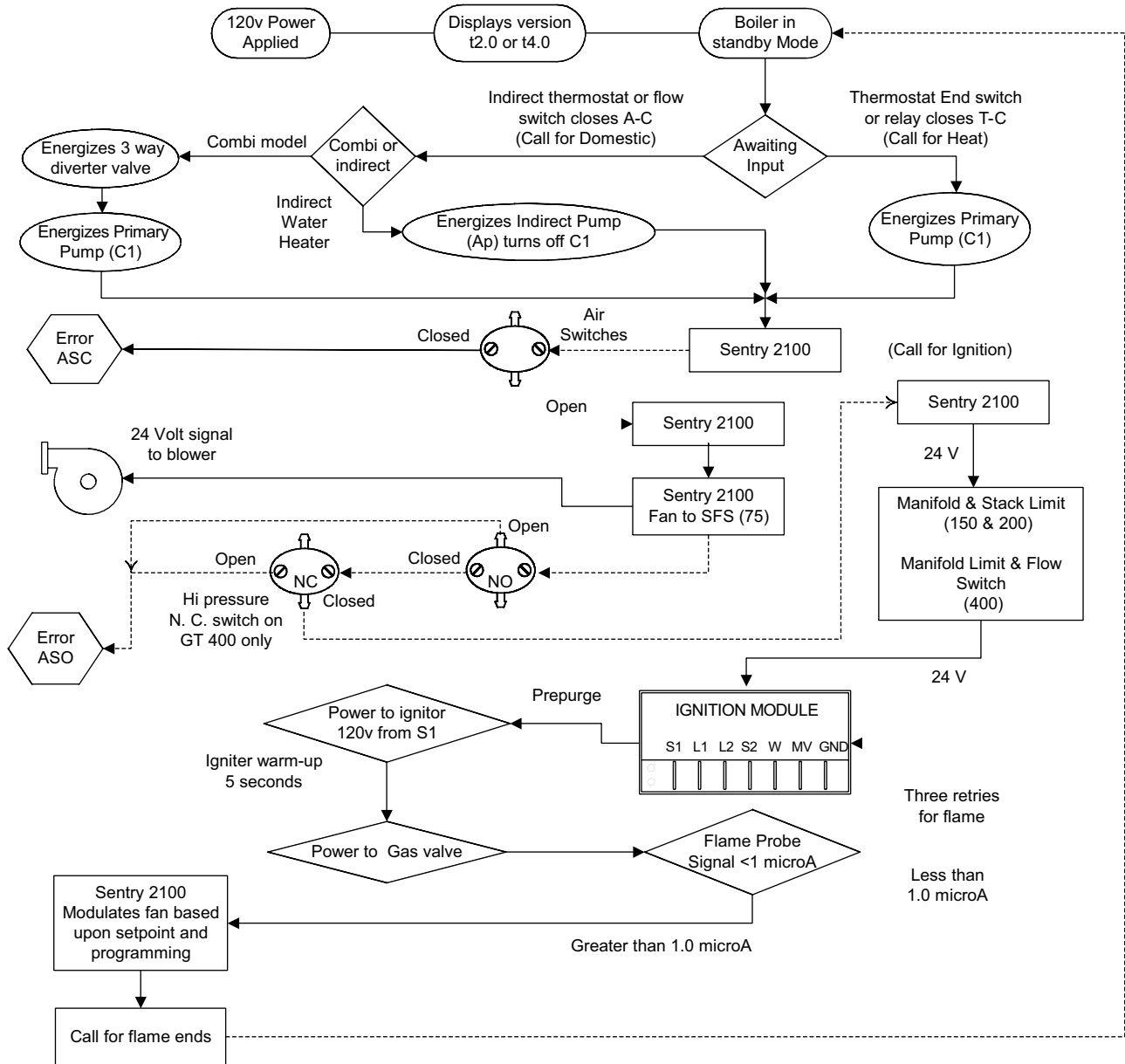

FOR YOUR SAFETY READ BEFORE OPERATING

WARNING: If you do not follow these instructions exactly, a fire or explosion may result causing property damage, personal injury or loss of life.

- A. This appliance does not have a pilot. It is equipped with an ignition device which automatically lights the burner. Do **not** try to light the burner by hand.
- B. BEFORE OPERATING smell all around the appliance area for gas. Be sure to smell next to the floor because some gas is heavier than air and will settle on the floor.

WHAT TO DO IF YOU SMELL GAS



- Do not try to light any appliance.
- Do not touch any electric switch; do not use any phone in your building.
- Immediately call your gas supplier from a neighbor's phone. Follow the gas suppliers instructions.

- If you cannot reach your gas supplier, call the fire department.
- C. Use only your hand to push in or turn the gas control knob. Never use tools. If the knob will not push in or turn by hand, don't try to repair it, call a qualified service technician. Force or attempted repair may result in a fire or explosion.
 - D. Do not use this appliance if any part has been under water. Immediately call a qualified service technician to inspect the appliance and to replace any part of the control system and any gas control that has been under water.

OPERATING INSTRUCTIONS

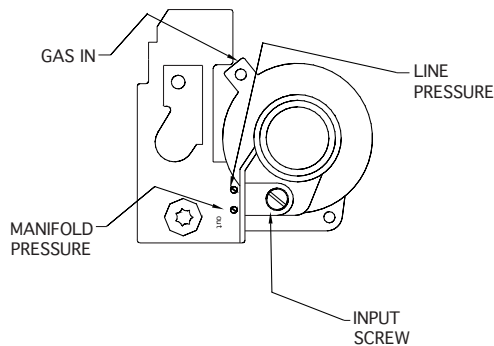
1. STOP! Read the safety information above.
2. Turn off all electric power to the appliance.
3. Set the thermostat to lowest setting.
4. This appliance is equipped with an ignition device, which automatically lights the burner. Do **not** try to light the burner by hand!



5. Remove control access panel.
6. Turn the manual gas supply shut off valve clockwise  to the full "OFF" position.
7. Wait five (5) minutes to clear out any gas. Then smell for gas, including near the floor. If you then smell gas STOP! Follow "B" in the safety information above. If you don't smell gas, go to the next step.
8. Turn the manual gas supply shut off valve counter-clockwise  to "ON".
9. Replace control access panel.
10. Turn on all electric power to the appliance.
11. Set thermostat to desired setting.
12. If the appliance will not operate, follow the instructions "TO TURN OFF GAS TO APPLIANCE" and call your service technician or gas supplier.

TO TURN OFF GAS TO APPLIANCE

1. Turn off all electric power to the appliance.
2. Set the thermostat to lowest setting.
3. Remove control access panel.
4. Turn the manual gas supply shut off valve clockwise  to the full "OFF" position.
5. Replace control access panel.

BOILER CHECKING & ADJUSTMENT

Input Rate

Gas appliances are rated based on sea level operation with no adjustment required at elevations up to **2000 ft, 610 m**. At elevations above **2000 ft, 610 m**, input ratings should be reduced by 4% for each **1000 ft, 305 m**, above sea level. Check the input rate as follows:

NATURAL GAS:

1. Turn off all other gas appliances that use the same gas meter as the boiler.
2. Call the gas company for the gas heating value.
3. Start the boiler and let it run for 15 minutes.
4. Using the gas meter and a stopwatch, clock the time that it takes to burn 10 cubic feet of gas and divide the time by 10.
5. Insert the heating value and the time, in seconds, into the formula below.

$$\text{Input Rate} = \frac{\text{Heating Value}(\text{Btu}/\text{ft}^3)(3600 \text{ s/hr})}{\text{Flow Rate}(\text{s}/\text{ft}^3)}$$

EXAMPLE: If the heating value = 1000 Btu/ft³
and the flow rate = 18 s/ft³

$$\text{Input Rate} = \frac{(1000 \text{ Btu}/\text{ft}^3)(3600 \text{ s/hr})}{18 \text{ s}/\text{ft}^3}$$

$$\text{Input Rate} = 200,000 \text{ Btu/hr}$$

If the computed rate deviates by more than 5% from the rated input value of the unit adjust the gas valve pressure according to the GAS PRESSURE ADJUSTMENT instructions that follow.

PROPANE GAS:

The input rate for LP units is factory set based on the orifice size. Use the factory supplied kit to convert the boiler to LP. A combustion analyzer must be used to ensure that the CO₂ reading falls between 9% and 10.5% with a CO reading of less than 175 ppm air free.

CAUTION: Never increase the input to the boiler above that for which it is rated. Doing so can cause premature failure of the boiler!

Gas Pressure Adjustment

Optimum results are obtained when the boiler is operated at its full input rating. If adjustment is necessary the following steps must be followed:

1. Connect a flue gas analyzer to the vent pipe.
2. Rotate the input adjustment screw clockwise to decrease the manifold pressure, counterclockwise to increase it, Figure 41 or 42. The input screw on the GX-150 & 200 is a multi turn needle valve. From fully open to fully closed is approximately 17 turns. A typical adjustment is 0 to 1 turn for natural gas, 0 to 3 turns for LP. The input screw on the GX-400 turns a geared ball valve with a 4 to 1 ratio. Two turns will take the valve from fully open to fully closed. 0 to 1/4 turn is a typical adjustment. Never force the input adjustment screw or the gas valve will be damaged!
3. For natural gas the CO₂ reading should fall between 8% and 9.5% with a CO reading of less than 175 ppm air free. For LP gas the CO₂ reading should fall between 9% and 10.5% with a CO reading of less than 175 ppm air free.

Main Burner Flame

A properly adjusted main burner flame will produce a tight blue flame pattern about **1/2 in, 13 mm**, tall from the burner's surface, Figure 44. A yellow floating or tall stringy flame is not normal and must be corrected.

WARNING: Yellow, floating flames indicate a lack of combustion air. DO NOT operate the boiler until the problem is solved or severe personal injury or death may occur!

Figure 44 - Burner Flame

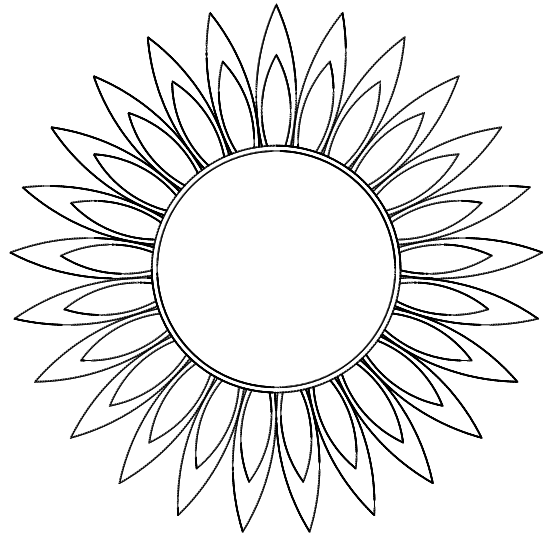

Thermostat Adjustment

Set the heat anticipator to 1.1 amps when controlling the boiler directly. For zoned systems set the heat anticipator to match the amp draw of the zone valves or pump relays.

BOILER MAINTENANCE

The boiler should be cleaned and inspected once a year, before each heating season.

CAUTION: Servicing, inspection and adjustment must be done by a trained technician in accordance with all applicable local and national codes. Improper servicing or adjustment could damage the boiler!

Controls

Use a soft brush and/or a vacuum cleaner to ensure that the electrical components are free from dust or deposits that would impair the boiler's performance.

Heat Exchanger Cleaning

Natural Gas - once every two years.

Propane - once per year.

The burner door should be removed so the combustion chamber can be inspected for flue gas blockage, see BURNER REMOVAL & REPLACEMENT below. Once the burner has been removed remove the heat exchanger baffle. Blockage of the heat exchanger will reduce the boiler's capacity/firing rate and can negatively impact on how smooth and efficiently the burner lights. Vacuum out any loose build-up and clean the heat exchanger surface with an appropriate cleaner for combustion chambers such as Sotin 300. Use a nylon or other non-metallic brush to loosen the sulfate incrustations and any other contaminants. Rinse with water allowing the solution to exit via the condensate drain. This process may warrant removing the insulation disc from the back of the heat exchanger.

Heat Exchanger Flushing

Listen for water flow noises that indicate a drop in the boiler water flow rate. The boiler and hydronic system may need to be flushed to eliminate hard water scale. A de-scaler such as Fernox DS-40 is recommend.

Burner Removal & Replacement

WARNING: The ceramic door disc on the rear of the burner contains crystalline silica. Wear proper respiration protection when servicing the burner and gently handle the burner and its disc to prevent inhalation of airborne fibers. Crystalline silica fibers have been identified as carcinogenic, or possibly carcinogenic when inhaled.

CAUTION: The burner should not be removed unless there is a problem with it. Careless handling can damage the burner!

1. Close the manual shutoff valve in the gas supply line and turn off electrical power to the boiler.
2. Remove the front and left jacket panels.
3. Disconnect the wires going to the igniter, flame rod, ground rod, blower and gas valve.
4. Carefully disconnect the gas piping at the union, Figure 27.
5. Carefully disconnect the air inlet piping at the valve, Figure 2.
6. Remove the nuts used to attach the burner to the heat exchanger.
7. Carefully slide the burner out of the unit.
8. Inspect the burner for damage or signs of deterioration. Use a brush or vacuum cleaner to remove any debris from the burner ports.
9. DO NOT install a damaged or badly corroded burner, replace it.
10. Inspect the ceramic burner disc for signs of damage or deterioration and replace it if necessary.
11. Inspect the burner door gasket for signs of damage or deterioration and replace it if necessary.
12. Inspect the ignition components for signs of damage or deterioration and replace them if necessary.
13. Reassemble the unit following the removal steps in reverse order.
14. All gas connections MUST be leak tested before putting the boiler into operation.

WARNING: Never use an open flame to test for gas leaks. Always use an approved leak detection method. Failure to comply with this WARNING could result in an explosion!

15. Confirm proper operation of the boiler and replace the jacket panels.

Condensate System

Ensure that the condensate removal system is clean, sound and working properly.

Vent System

The entire vent system must be thoroughly inspected for any signs of blockage, damage or leaks. Immediately replace any unsound vent system piping. Remove any foreign matter in or near the vent and air inlet terminals that might obstruct them.

Low Water Cutoff

If the system has been equipped with a low water cut-off device, follow the manufacturer's instructions for cleaning and to confirm proper operation

Relief Valve

The relief valve should vent water when the test lever is lifted. It should not weep or discharge water at normal system pressure. NEVER try to clean or repair the relief valve! If the valve fails replace it!

Aquastat High Limit

The aquastat high limit controls the maximum water temperature in the boiler. If the water temperature reaches the set temperature before the demand for heat has been met, the aquastat high limit should shut the burners off. The outlet water temperature should never exceed **220°F, 104°C**. If the aquastat high limit fails to function properly replace it.

WALL HUNG CONVERSION

This boiler is certified to be either mounted on the floor as supplied, or mounted on a wall.

For wall mounting, perform the following steps.

1. Ensure that the desired location provides adequate room for the clearance, see Table 1, venting, and servicing.
2. Remove the right stainless steel panel, and discard.
3. You will see that underneath the panel, the boiler frame has mounting holes, designed for wall attachment.
4. The boiler must be mounted so the lag bolts enter the studs of the wall. If this is not possible use a 3/4" thick of plywood approximately **24 in, 610 mm**, wide by **36 in, 914 mm**, high.
5. Install two #14-3" lag bolts three quarters of the way into the surface, to the height you desire for mounting.
6. Lift the boiler onto the wall, and tighten the top lag bolts.
7. Once the unit is level, install the bottom two #14-3" lag bolts.
8. Remove the Air Inlet Pipe assembly and Metering elbow from the gas valve-venturi assembly, Figure 45.

Figure 45 - Air Inlet Pipe Removal

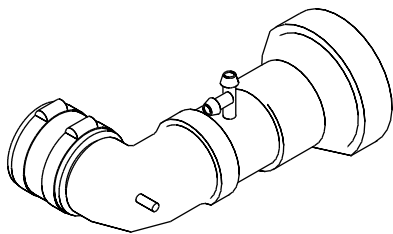

9. Remove the two screws attaching the gas valve-venturi assembly to the side of the blower and rotate the valve 90° so the 1/2" threaded connection is pointing down, Figure 46. Pay close attention to how the cork gasket is aligned.

Figure 46 - Gas Valve Rotation

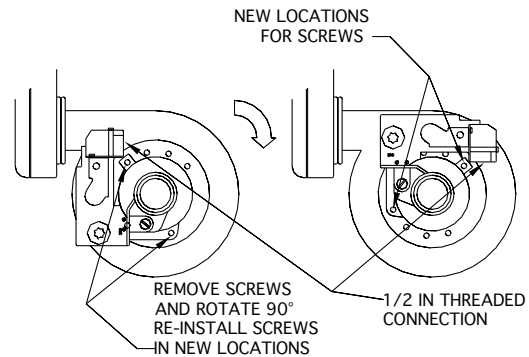

10. Reattach the gas valve-venturi assembly to the side of the blower making sure the gasket is correctly orientated.
11. Re-install the Air Inlet Pipe assembly and Metering elbow from the gas valve-venturi assembly, in the vertical position, Figure 47.

Figure 47 - Air Inlet Pipe Installation

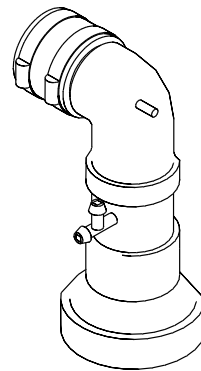

12. Install the gas line as per Figure 48 and follow the instructions in the GAS PIPING section of this manual.

Figure 48 - Gas Supply Piping

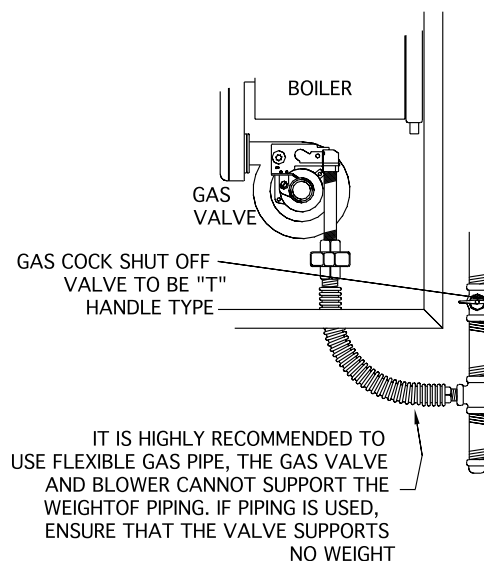

TROUBLE SHOOTING

This section is intended to assist the service technician in detecting and correcting common errors. The Sentry 2100 is equipped with an internal diagnostic system that verifies control operation. The following series of error codes has been developed to aid in diagnosing control problems:

Problem	Detected Problem	Solution
ER1 On Display	The Safety High Limit of 215°F, 102°C , has been reached.	<ol style="list-style-type: none"> 1. Check to see if water is dripping on the sensor. 2. Reduce the Hi setting (and/or) ensure that there is proper water circulation in the system.
ER2 On Display	Water Probe... The water probe is transmitting an invalid signal - closed circuit.	Check wiring
ER3 On Display	Water probe...Sentry is sensing an open circuit at water probe. Or, the wiring to the outdoor probe is grounded.	<p>Check wiring. (Note: ER3 will be displayed if temperature sensed is less than 32°F, 0°C.)</p> <p>Note: If problem is corrected by resetting power, Sentry control had locked-up; contact Hydrotherm.</p>
ER5 On Display DHW Problem	The control has determined an Indirect water heater problem; the boiler has cycled off 10 times during a single call for domestic. The Indirect call will now be ignored until power is reset or the indirect call is interrupted.	<ol style="list-style-type: none"> 1. Not enough flow to keep boiler from tripping on limit. Verify that a min. of 6 GPM, 0.4 L/s, flow is going through boiler & indirect circuit. 2. Reduce indirect Aquastat setting, or Increase difference between (Lo Setting) and (indirect Aquastat setting). 3. Indirect limit or wiring failure.
ER6	“Flame Lock Out” Sentry has sensed a lack of 24V to the gas valve during operation or a Fenwal ignition lockout.	<ol style="list-style-type: none"> 1. There is a problem in the ignition sequence; it could be caused by a faulty igniter, flame sensor, gas valve or improper line pressure or combustion. Check ignition sequence to determine which component is not functioning. <i>(Sentry will retry ignition sequence 1 hour after ER6 code originally occurs or if control is reset)</i> 2. Check for 24V between B on terminal block and F1 on Sentry plug, if not present a limit has tripped (see wiring diagram). 3. the Flow Switch on the GX-400 is also in the 24V circuit. Check for proper water flow and flow switch operation.
Burner shuts off before set-point temperature is reached (and burner light goes out)	Reset calculation being used to lower HI setting.	If OD probe is being used, the HI setting will be calculated using formula in Section 8.
	Thermostat is satisfied	<ol style="list-style-type: none"> 1. If the thermostat demand light is turning off, the thermostat has satisfied. 2. If DHW temp light is turning off; the aquastat or call for domestic has been satisfied.

Problem	Detected Problem	Solution
ASO Indicates that the Air Switch is Open	This is displayed when the boiler is expecting the air switch to be closed by a differential pressure generated when the combustion blower turns on. It can occur momentarily during normal operation. A problem is indicated when ASO is displayed continuously.	<ol style="list-style-type: none"> 1. Are the vinyl tubes connected between the air switch and the ports on the inlet pipe. Negative side of switch connects to the port on the 1 1/2 in, 38 mm, ABS elbow. 2. Check for blockage on the intake and exhaust vents. 3. If fan is running, air switch may be faulty, ensure that it's set for 0.2 in, 5.1 mm WC. The GX-400 condensate drain switch must be set at 3 in, 76 mm WC. 4. If fan is not running, check 120V wiring to blower, if ok remove low voltage harness from blower, if blower fails to start, replace blower, if blower does start problem may be with blower or Sentry control.
ASC Indicates that the Air Switch is Closed	This is displayed when the boiler has turned the blower off and is expecting the air switch to be open. It can occur momentarily during normal operation. A problem is indicated when ASC is displayed continuously.	<ol style="list-style-type: none"> 1. Is the fan running. If so check for 24V between C and D terminals, see wiring diagrams. If 24V is not present replace transformer. 2. Check venting termination with required venting described in manual.
Ignition Sequence not activated when burner light is on (Fan is on and Fenwal not flashing)	Check for 24 Volts between terminal B1 on Sentry & Ground.	<ol style="list-style-type: none"> 1. If there is 24V, indicates faulty wiring between BI and W1 on Fenwal, or faulty Fenwal. 2. If 24V is not present proceed to next step.
	Check for 24 Volts between terminal F1 on Sentry & Ground.	<ol style="list-style-type: none"> 1. If 24V exists here but not at B1, indicates faulty relay inside Sentry, contact NTI, replace control. 2. If 24V is not present check for 24V at transformer. 3. If 24V exists at transformer, check wiring and safety limits. If 24V not present at transformer, check wiring and replace transformer if necessary.
	Water Safety Limit trips (Automatic reset) Located in the supply manifold inside the boiler cabinet.	<p>May be caused by an error in the reading of the water temperature by the Sentry control. Watch cycle, and ensure the Sentry is displaying the correct water temperature and is modulating.</p> <p>This device protects the boiler from overheating due to a lack of flow passing through the unit when the burner is on. FLOW MUST NEVER BE BLOCKED BY ANY VALVES INCLUDING MIXING OR ZONE VALVES. Install unit as described in this manual.</p>

Problem	Detected Problem	Solution
Ignition Sequence not activated when burner light is on (Fan is on and Fenwal not flashing) <i>continued</i>	Stack Safety Limit Trips (Automatic Reset) Located on the front of the flue box.	This device protects the integrity of the plastic venting material. If the temperature of the flue gases exceeds 225°F, 107°C , the limit will cut power to the control. Blocked internal tubes can increase the stack temperature to an unacceptable level. Flush out the boiler.
Two Flashes on Fenwal	The Fenwal controller thinks that there is a flame prior to ignition.	If the combustion sequence is normal, and there is no flame prior to ignition, the Fenwal control is defective, and must be replaced.
Three Flashes on Fenwal	Indicates Ignition Lockout.	<p>If the condensate drain gets blocked, the boiler will become flooded, and terminate operation, as the flame rod becomes immersed. This will damage the flame probe. To correct, free the drain blockage, and permanently prevent it from reoccurring. Remove and dry off the probe. Reinstall the probe and try for ignition, if it fails to ignite, leave the fan run for up to three hours to dry out the insulation and probe.</p> <p>Reset Boiler so it will attempt to ignite. Check for proper operation of ignition components. Make sure igniter glows and gas valve opens. Check for proper line pressure at gas valve when it opens. If boiler lights check for flame signal between FC1 And FC2 on Fenwal control. If lower then 1.2 micro amps see Boiler will not stay lit below. Check combustion properties.</p>
Boiler will not stay lit.	Indicates lack of a good flame signal. In order to stay running the flame signal must be at least 0.7 micro Amps.	If the Burner light on the Sentry is going out, go to "Burner shutting off". Check condensate drain for blockage and check the inlet piping for ingested snow or water (if the flame rod gets wet, it may need to be replaced). Check for resistance from flame rod to ground, must be an open circuit (O.L). Check for proper polarity of line and neutral wiring to the boiler.
Boiler bangs or hisses	Bangs or sounds like a kettle while burner is running indicating insufficient flow.	Ensure the plumbing is as shown in manual. Check to see if pumps are faulty or end switches are stuck. This problem can lead to boiler overheating!

Problem	Detected Problem	Solution
Sentry Controller Locks-up	Excessive noise, current, or voltage spikes in the 120V power supply.	<p>Check for voltage at the wires going to the A-C-T terminals of the Boiler.</p> <p>Check the magnitude of the line voltage power supply.</p> <p>Check the Amp draw of output C1 and Ap (max 3 Amp).</p> <p>Check the Amp draw of control on start-up (max 6 Amps)</p> <p>Contact Hydrotherm.</p>
Display Goes Blank	No power to control or control failure.	<p>Check for 120V between terminals L1 and L2 at Sentry.</p> <p>If 120V exists turn power off and remove line voltage harness from Sentry. Then check for resistance between L1 and L2 of control, if the circuit is open (O.L) the internal fuse has blown. Check for shorts in wires leading to circulators prior to replacing controller.</p> <p>If 120V not present, check wiring and for 120V at source.</p>
Boiler Lights rough or pulsates	Typically an imbalance in the air to gas ratio.	<p>Ensure that the venting lengths are in compliance with the venting sections above.</p> <p>Ensure that the line pressure during operation does not drop more than 20% from the static line pressure.</p> <p>Momentarily remove the intake vent from the boiler during ignition, if unit lights smoothly with intake vent disconnected reconnect and check for proper combustion if unit maintains smooth operation after ignition. Calibrate for proper combustion. If problem persists contact Hydrotherm.</p>
Fan appears to be creating a noise in the housing	Slight vibration can cause noise in the residence. This is not a warranty issue.	<p>Use flexible gas line to insolate the vibration noises between the gas valve and the line.</p> <p>Don't hang gas lines from floor joists.</p> <p>Use rubber insulators with gas line supports.</p>
	Making a rubbing noise. This is not a warranty issue.	<p>If gas valve is not held when the gas nipple is connected, the force of tightening the fitting can damage the valve, and warp the fan housing.</p> <p>If pipe is used, the gas line must not create any forces to the valve, either vertically (weight of line), or horizontally (misaligned connection)</p>

The following are the thermister curves for diagnosing the water and outdoor air sensors.

1. Measure the resistance of the thermister when disconnected.
2. Using the appropriate chart, find the resistance and move vertically for the water probe or horizontally for the air probe until the line is intersected.
3. Move 90 degrees to the corresponding temperature.
4. If the temperature is plus or minus **10°F**, - **12 °C**, then the probe is operating correctly.

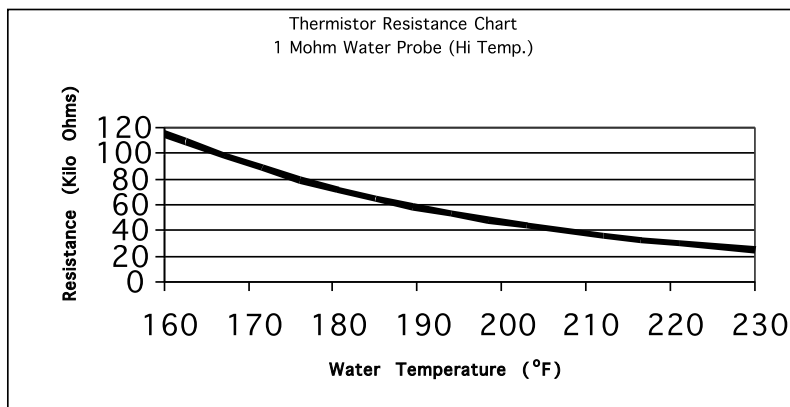
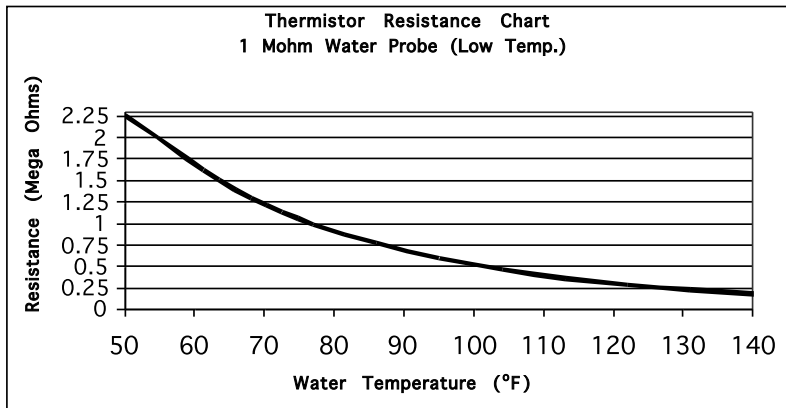
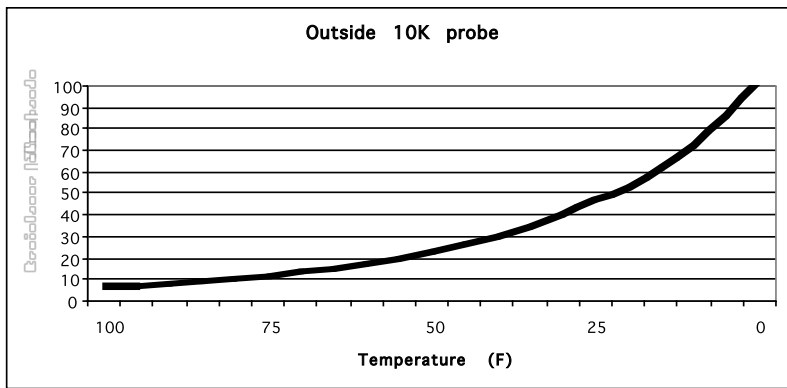

REPLACEMENT PARTS LIST

Replacement parts are available from your stocking wholesaler. Homeowners must contact their local installer or wholesaler.

Figure 48 - Replacement Parts Exploded View - Models GX150 and GX200

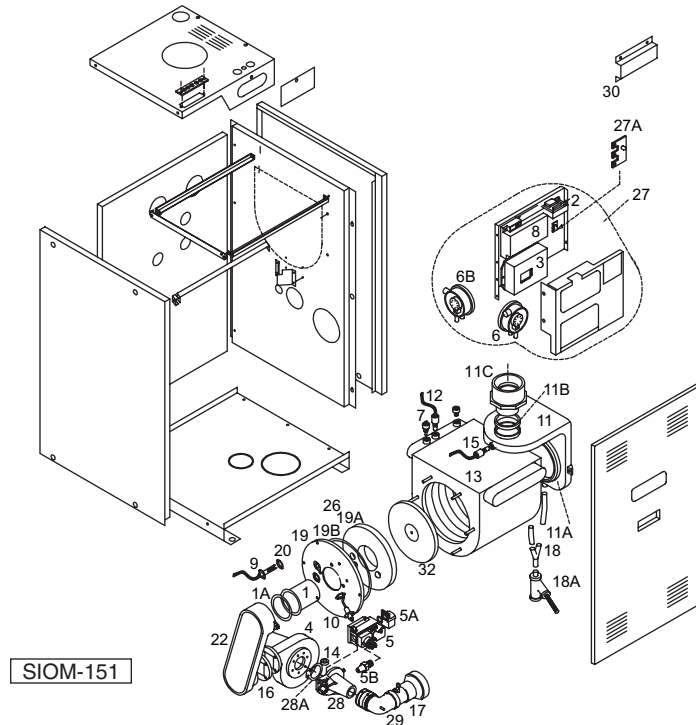

Item	Part Number	Description
1	GX-82657	Premix burner, 135.8 – 150 Only
1	GX-82658	Premix burner, 200.6 – 200 Only
1A	GX-82761	Premix Burner Gasket
2	GX-82457	Transformer, 24V
3	GX-82013	Sentry 2100
4	GX-82052	Blower #RG130 – 150 Only
4	GX-82661	Blower #RG148/1200 – 200 Only
5	GX-82054	Gas Valve (CVI) VK81 15F1134B
5A	GX-82065	Gas Valve 1/2" npt elbow
5B	GX-82600	Gas Valve Vent connection
6	GX-82662	Air switch Huba @ .15"wc.
7	GX-82671	Thermister #T7335C2016 1 Mohm (150-200)
7	GX-83035	Thermister NTC 1/4" NPT, 1 Mohm (150ASME)
8	GX-82058	Ignition Moduel Fenwal #2465H
9	GX-82708	IGNITER, #601, c/w SS Heat shield
10	GX-82762	Rauscchert Flame Rod
11	GX-82763	Composit Flue Box
11A	GX-82764	Composit Flue Box Gasket
11B	GX-82765	Composit Flue Outlet Gasket
11C	GX-83291-1	Flue Adapter Assembly
12	GX-82659	Manifold Limit, 1/8BSP, Brass (150-200)
12	GX-82992	Manifold Limit, 1/4NPT, Brass (150 ASME)
13	GX-82596	150 non-ASME Heat Exchanger
13	GX-83012	150 ASME Heat Exchanger
13	GX-82647	200 Heat Exchanger
14	GX-82650	LP orifice 5.20mm – 150-200 Only
15	GX-82660	Stack Limit, 1/4BSP, SS, 190F, Dif=30
16	GX-82766	Blower gasket 150 Only

Item	Part Number	Description
16	GX-82719	Blower gasket 200 Only
17	GX-82622-1	Inlet Pipe assembly
18	GX-82127	Condensate nylon Y
18A	GX-82913	Siphon Condensate Trap
19	GX-82767	Cast aluminum Burner door
19A	GX-82769	Ceramic burner door disc
19B	GX-82770	Burner door gasket
20	GX-82768	Igniter gasket
22	GX-82771	Extended air tube
27	GX-82754	Complete Control panel & Harness
27A	GX-82754-1	PCB Optocoupler
28	GX-82054-1	CVI Venturi 01 – 150-200 Only
28A	GX-82054-2	CVI Venturi Gasket
29	GX-82104-1	Air metering Elbow
30	GX-81027-1	Sentry 2100 (10k) Outdoor Air Sensor
31	GX-83223	1/8NPT Water Pressure Switch (after 5-1-06)
31	GX-83223-1	1/4NPT Water Pressure Switch (150 ASME)
32	GX-83112	Divider Plate Insulation c/w washer and screw
A	GX-82976-A	Stainless steel Top
B	GX-82976-B	Electrical box cover
C	GX-82976-C	Stainless steel Left side
D	GX-82976-D	Stainless steel Right side
E	GX-82976-E	Stainless steel Front Door
F	GX-82976-F	Galvanized Right Side
G	GX-82976-G	Galvanized Bottom base
H	GX-82976-H	Bottom Base support
I	GX-82976-I	Galvanized Back

REPLACEMENT PARTS LIST

Replacement parts are available from your stocking wholesaler. Homeowners must contact their local installer or wholesaler.

Figure 49 - Replacement Parts Exploded View - Model GX400

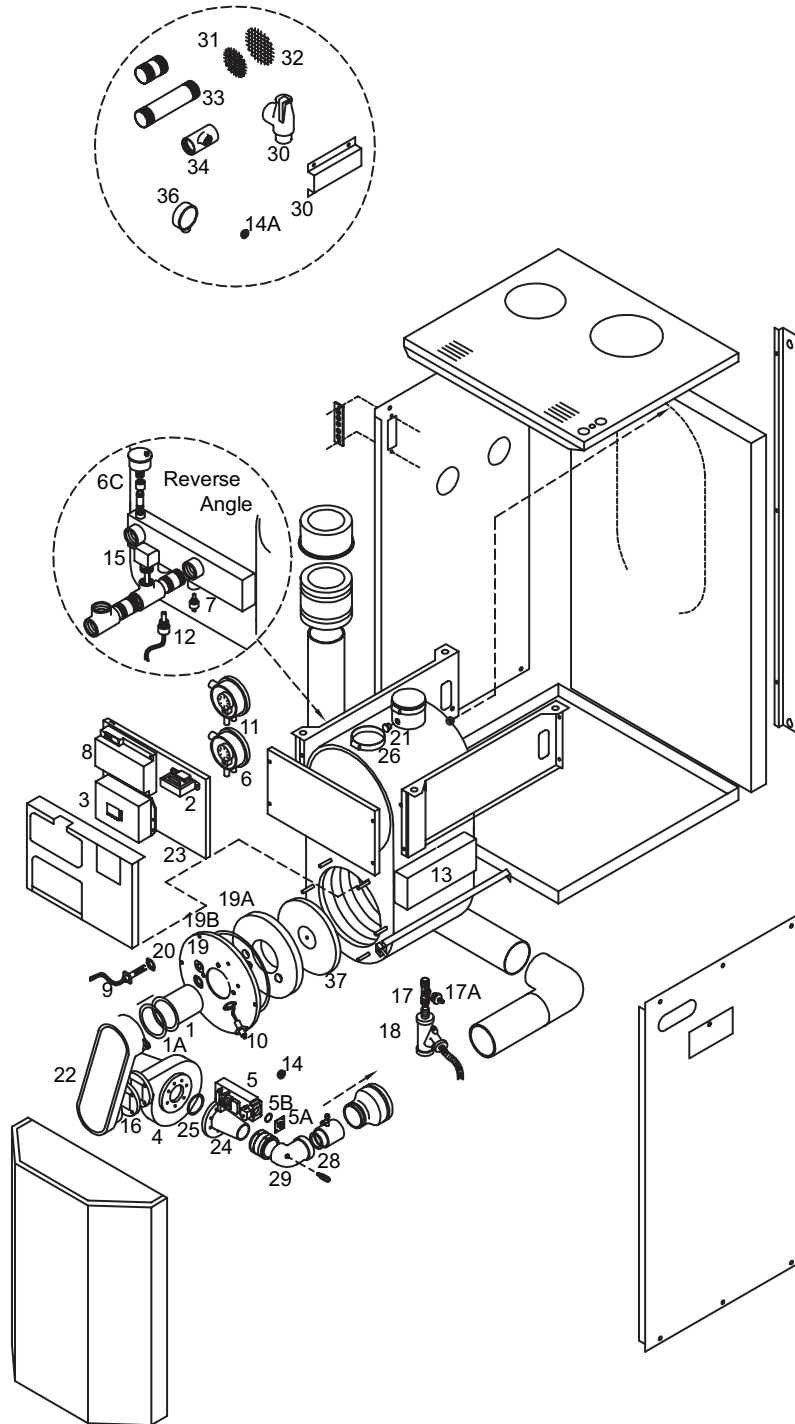

SIOM-152

Item	Part Number	Description
1	GX-83173	Premix Burner (For 400)
1A	GX-82761	Premix Burner Gasket
2	GX-82457	Transformer, 24V
3	GX-83171	Sentry 2100 Assembly
4	GX-82994	EBM BLOWER #RG148/E
5	GX-82989	Gas Valve VR8615VB 1044B
5A	GX-82991	Gas Valve Adapter, 3/4" NPT
5B	GX-83194	Gas Valve Connector O-ring
	GX-83016	Gas Valve Harness
6	GX-82662	Air switch Huba @ 0.2"wc.
6C	GX-82539	Air Vent
7	GX-83035	Thermister NTC 1/4" NPT, 1Mohm
8	GX-82058	Ignition Module (Fenwal)
9	GX-82708	IGNITER, #601, c/w SS Heat shield
10	GX-82762	Flame Rod Rauschert
11	GX-82906	Air Switch 604.E421180 set @ 3" wc
12	GX-82992	Limit Switch, 1/4"NPT, (Manifold)
13	GX-82926	400 Heat Exchanger, ASME
14	GX-82993	Gas Valve Orifice, 8.0mm, NG
14A	GX-83017	Gas Valve Orifice, 6.2mm, LP
15	GX-81887	Flow Switch, FS-10C
16	GX-82766	Blower Gasket

Item	Part Number	Description
17	GX-83037	TEE NYLON 3/4"HB to 3/4"
17A	GX-83038	ADAPTER NYLON, 3/4" x 1/4"
18	GX-82913	SIPHON CONDENSATE TRAP
19A	GX-82769	Burner Door Ceramic Disc
19B	GX-82770	Burner Door Viton Gasket
20	GX-82768	Igniter Gasket
21	GX-83034	Exhaust Test Plug
22	GX-83195	Extended Air Tube
23	GX-83141	Control Panel, Complete
24	GX-82990	CVI Venturi
25	GX-83106	O-ring, Venturi to Blower
26	GX-83001	Test Port Retaining Clamp
27	GX-82754-1	PCB Optocoupler
28 29	GX-83170-1	Air Metering Assembly
30	GX-81027-1	Sentry 2100 (10K) Outdoor Probe
31	GX-83018	Vent Screen, 4"
32	GX-83019	Vent Screen, 6"
33	GX-83013	Nipple, 1-1/4" x 8", Brass
34	GX-83005	1-1/4"x 1-1/4"x 3/4" Tee Brass
35	GX-13701	RELIEF VALVE 3/4" #335 30 PSI
36	GX-82148	PRESSURE GAUGE 0-30 PSI
37	GX-83112	Divider Insul. (c/w washer & screw)

Advanced Thermal Hydronics

IN UNITED STATES: 260 NORTH ELM ST., WESTFIELD, MA 01085 • (413) 564-5515 FAX (413) 568-9613
IN CANADA: 7555 TRANMERE DRIVE, MISSISSAUGA, ONTARIO L5S 1L4 • (905) 672-2991 FAX (905) 672-2883