

**MCU Kit**

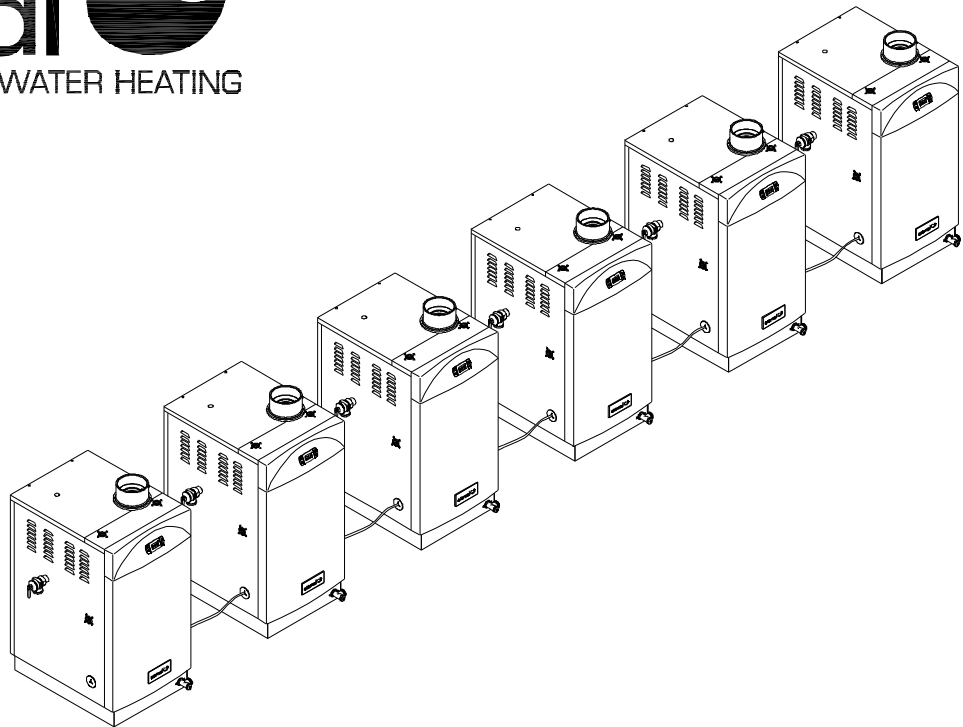

**Service Information Center:**

**Call us first** if you have any questions with this product. We can help you with questions about assembly and Water Heater operation or if there are damaged or missing parts when you unpack this unit from the shipping box. Please call before returning to the store.

**1-866-946-1096**  
 8am-4:30pm CST, Monday through  
 Friday

**Table of Contents**

MCU Kit Components.....	2
Specifications and Features.....	3
MCU Installation in Eternal Water Heater.....	4-6
Water Pipe Sizing.....	7
Gas Pipe Specification.....	8
Unit Clearance.....	8
Power Supply Schematic Diagram.....	9
Plumbing Diagrams.....	10-12
Unique Unit Identification Number.....	13
Termination Setting.....	14
MCU Operation Sequence Flow Chart.....	14
Warranty.....	15

**IMPORTANT:**

- **Only specially trained and authorized personnel are permitted to service this water heater.**
- **NOTE TO ASSEMBLER / INSTALLER:**  
 Leave this manual with the consumer.
- **NOTE TO CONSUMER:**  
 Keep this manual for future reference.



**WARNING**



California Proposition 65 lists chemical substances known to the state to cause cancer, birth defects, death, serious illness or other reproductive harm. This product may contain such substances, be their origin from fuel combustion (gas, oil) or components of the product itself.



**WARNING**



Read this Operator's Manual carefully and be sure your Water Heater is properly assembled, installed and maintained. Failure to follow these instructions exactly could result in a fire or explosion, serious bodily injury and/or property damage.

Do not store or use gasoline or other flammable vapors and liquids in the vicinity of this or any other appliance.

# MCU Kit Components

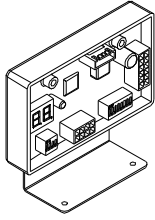

MCU Module with Bracket

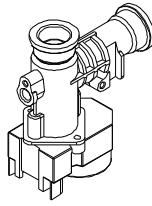

Staging Valve

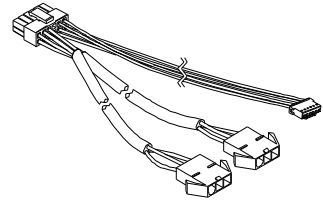

12P MCU Wire

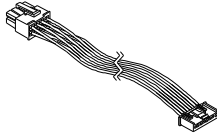

8P MCU Wire

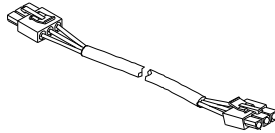

3P MCU Wire

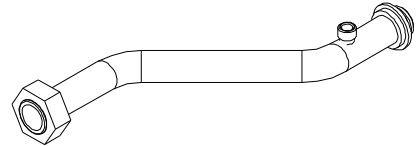

Hot Water Tube M1

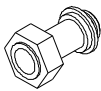

Hot Water Tube M2



WPS Nipple

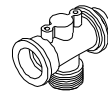

WS Nipple

## Hardware

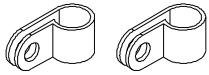

Cable Clamp-2pc



Tube Packing 1/2P-1pc



Tube Packing 3/4P-2pc



O Ring P4-1pc

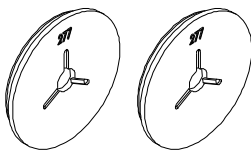

Hole Plug-2pc



Philips Head Screw-2pc



Self Tapping Screw-2pc

## Specifications and Features

### Applicable Models:

501 Series - GU20 / 26 / 28 / 32

505 Series - GU20DV / 26DV / 28DV / 32DV

### Affected Serial #s:

GU32 prior to G800839 requires PCB upgrade for MCU compatibility

GU26 prior to G801085 requires PCB upgrade for MCU compatibility

### Description:

MCU kit allows multiple Eternals to be linked {required on 3 or more units, 1 kit per unit} together in parallel manifold configuration. By doing so, Eternals can be suitable for large commercial projects. such as motels, apartment complexes and laundromats etc...

### Specifications

Dimensions (MCU module)	3.94"W x 0.78 "D x 1.77 "H
Weight (MCU module)	Less Than 1 lb

### Features and Benefits

- High Tech CANBUS Protocol ensures good communication between units.
- Alternate Host Firing distributes wear and tear across all units every 24 hours.
- Redundency program allows remaining units to work when a units breaks down.
- Synchronized temperature control changes settings on all units from any unit.
- Up to 16 Eternals can be networked and mixed and matched, i.e. 2 x GU26s + 3 x GU32s.
- Automated staged firing allows as little or as much units to fire up as needed.
- Automated load balancing distributes the work across necessary units evenly.
- Built-in digital monitor on MCU module for easy diagnostics.
- UL1998 Certified.

## MCU Installation in Eternal Water Heater

1. With all taps closed and unit off, unplug the power cord of the unit from the power outlet.
2. Using a small wrench, loosen the nut holding the outlet thermistor in hot water outlet tube and extract the outlet thermistor from the tube. Be careful not to lose the O-Ring on the thermistor.
3. Unplug the two wires attached to the Water Pressure Sensor and hand loosen the sensor to remove from the hot water outlet tube.
4. Loosen the brass nut attaching the hot water outlet tube to the water fitting near the top of the unit, and loosen the brass nut attaching the hot water outlet tube to the T-Connector near the heat exchanger tank.
5. Remove the factory original hot water outlet tube and replace with the hot water staging valve assembly (Hot Water Tube M1 + Staging Valve + Hot Water Tube M2). Secure the assembly to the water fitting and the T-Connector with brass nuts.

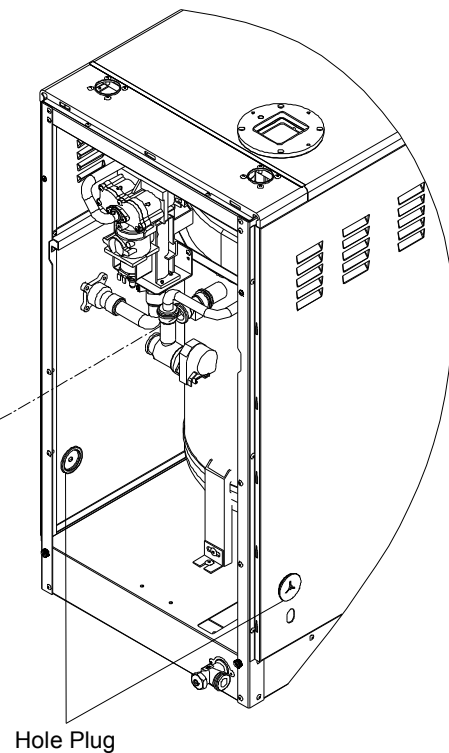
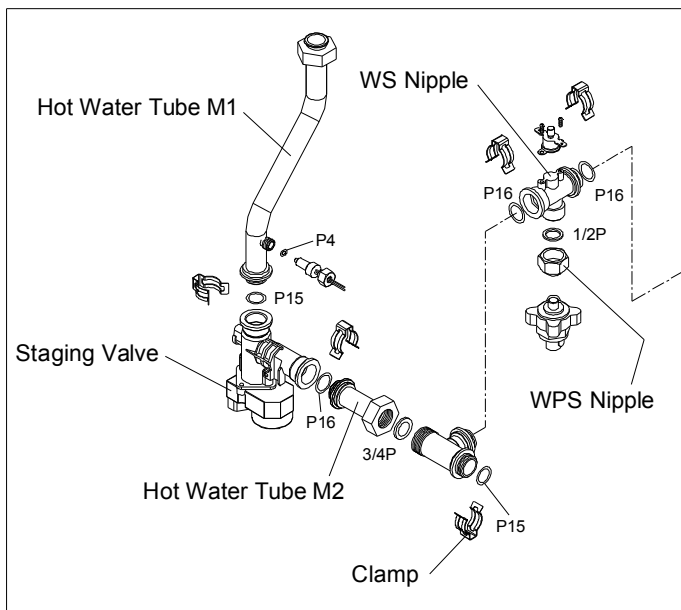
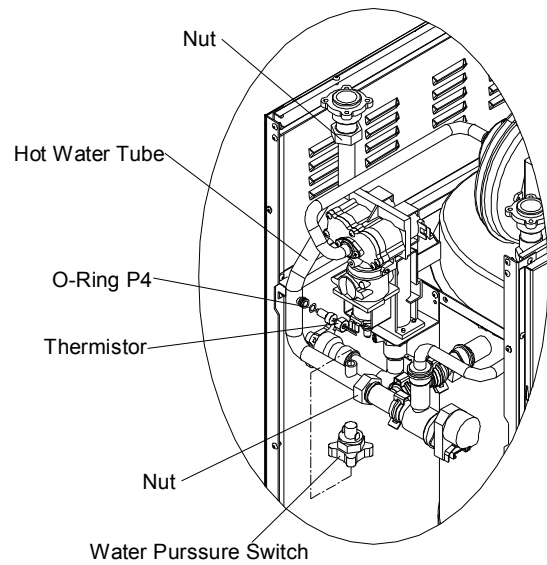

6. Insert outlet thermistor into Hot Water Tube M1 and make sure the O-Ring is secure to prevent leak.
7. Re-install the Water Pressure Switch onto the WPS Nipple. Attach the WPS Nipple and O-Ring to the WS Nipple and ensure all connections are secure to prevent leak.
8. Push open the hole(s) reserved on either or both sides and insert the Hole Plug to allow wire access.

## MCU Installation in Eternal Water Heater

9. Install MCU module on the bottom panel of water heater with the included self tapping screws-2pc.

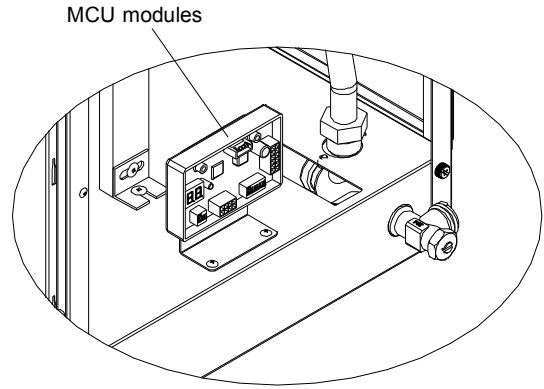

10. Connect the 8P MCU wire connector to the MCU Module.

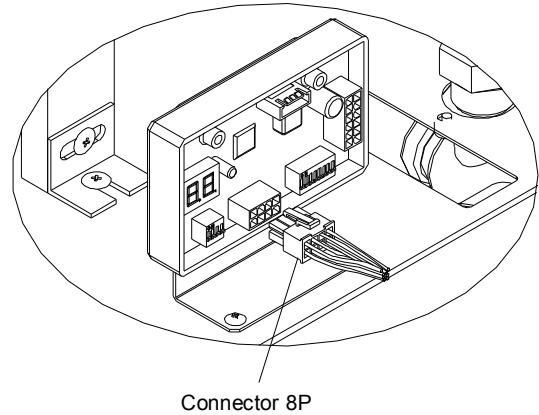

11. Connect the other end of the 8P MCU wire connector to the staging valve.

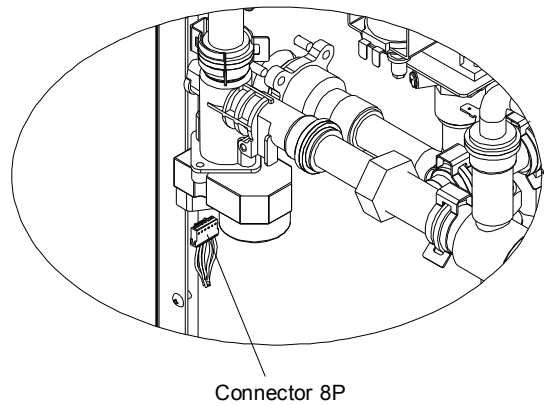

12. Connect the 12P MCU wire connector to the MCU Module.

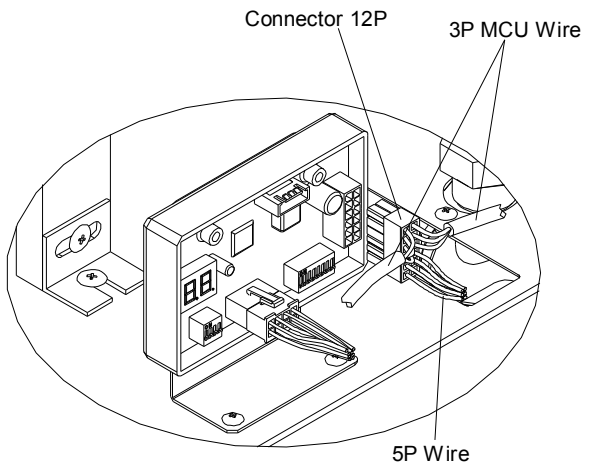

## MCU Installation in Eternal Water Heater

13. Connect the 3P MCU wire connector which extends from the 12P MCU wire connector to the other 3P MCU wire connector extending from another Eternal unit next in line.

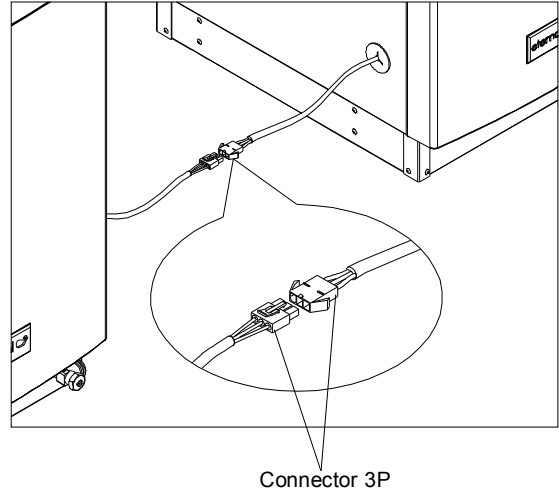

14. Connect 5P wire connector to Main Controller of the water heater.

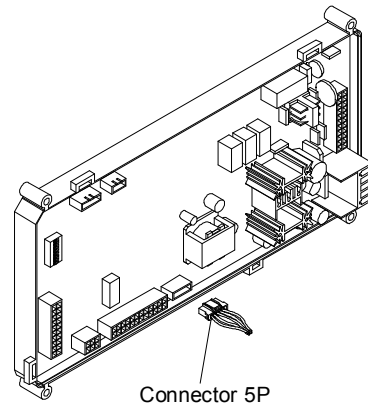

15. Secure the 3P MCU wire connectors to the bracket via the included cable clamps-2pc.

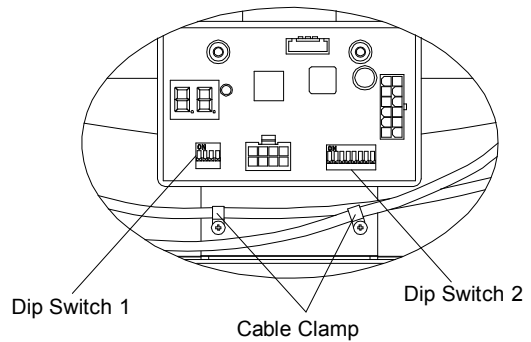

16. Repeat the installation procedure for remaining Eternal water heaters to be used in the MCU application.
17. Make sure all the units are properly configured (Unit ID# and Network Termination).
18. Turn on the power to all the units and while power is supplied to the units move dip switch #4 to ON position on the Main Controllers of the units installed with MCU modules.

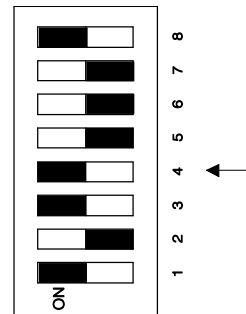

# Water Pipe Sizing

## 1. Supply pressure 30 - 39 psi

Meter and street service pipe (inches)	Distribution pipe (inches)	GPM Capacity per Length of Pipe (ft)								
		40'	60'	80'	100'	150'	200'	300'	400'	500'
3/4	1/2	2.5	2	1.5	1.5	1	1	0.5	0	0
3/4	3/4	9.5	7.5	6	5.5	4	3.5	2.5	2	1.5
3/4	1	32	25	20	16.5	11	9	6.5	5.5	4.5
1	1	32	32	27	21	13.5	10	7	5.5	5
1	1 1/4	80	80	70	61	45	34	22	16	12
1 1/2	1 1/4	80	80	80	75	54	40	25	17.5	13
1	1 1/2	87	87	87	87	84	73	56	45	36
1 1/2	1 1/2	151	151	151	151	117	91	69	54	43
2	1 1/2	151	151	151	151	128	99	72	56	45
1 1/2	2	275	275	275	275	258	223	174	144	122
2	2	365	365	365	365	318	266	201	160	134
2	2 1/2	533	533	533	533	533	495	409	353	311

## 2. Supply pressure 40 - 49 psi

Meter and street service pipe (inches)	Distribution pipe (inches)	GPM Capacity per Length of Pipe (ft)								
		40'	60'	80'	100'	150'	200'	300'	400'	500'
3/4	1/2	3	2.5	2	1.5	1.5	1	0.5	0.5	0.5
3/4	3/4	9.5	9.5	8.5	7.5	5.5	4.5	3	2.5	2
3/4	1	32	32	32	26	18	13.5	9	7.5	6
1	1	32	32	32	32	21	15	9.5	7.5	6.5
1	1 1/4	80	80	80	80	65	52	35	26	20
1 1/2	1 1/4	80	80	80	80	75	59	39	28	21
1	1 1/2	87	87	87	87	87	87	78	65	55
1 1/2	1 1/2	151	151	151	151	151	130	93	75	63
2	1 1/2	151	151	151	151	151	139	98	77	64
1 1/2	2	275	275	275	275	275	275	238	198	169
2	2	365	365	365	365	365	349	270	220	185
2	2 1/2	533	533	533	533	533	533	528	456	403

## 3. Supply pressure 50 - 59 psi

Meter and street service pipe (inches)	Distribution pipe (inches)	GPM Capacity per Length of Pipe (ft)								
		40'	60'	80'	100'	150'	200'	300'	400'	500'
3/4	1/2	3	3	2.5	2	1.5	1	1	0.5	0.5
3/4	3/4	9.5	9.5	9.5	8.5	6.5	5	4	3	2.5
3/4	1	32	32	32	32	25	18.5	12	9.5	8
1	1	32	32	32	32	30	22	13	10	8
1	1 1/4	80	80	80	80	80	68	48	35	28
1 1/2	1 1/4	80	80	80	80	80	75	53	39	29
1	1 1/2	87	87	87	87	87	87	87	82	70
1 1/2	1 1/2	151	151	151	151	151	151	120	94	79
2	1 1/2	151	151	151	151	151	151	126	97	81
1 1/2	2	275	275	275	275	275	275	275	247	213
2	2	365	365	365	365	365	365	329	272	232
2	2 1/2	533	533	533	533	533	533	533	533	486

## 4. Supply pressure over 60 psi

Meter and street service pipe (inches)	Distribution pipe (inches)	GPM Capacity per Length of Pipe (ft)								
		40'	60'	80'	100'	150'	200'	300'	400'	500'
3/4	1/2	3	3	3	2.5	2	1.5	1	1	0.5
3/4	3/4	9.5	9.5	9.5	9.5	7.5	6	4.5	3.5	3
3/4	1	32	32	32	32	32	24	15.5	11.5	9.5
1	1	32	32	32	32	32	28	17	12	9.5
1	1 1/4	80	80	80	80	80	80	60	46	36
1 1/2	1 1/4	80	80	80	80	80	80	65	50	38
1	1 1/2	87	87	87	87	87	87	87	87	84
1 1/2	1 1/2	151	151	151	151	151	151	144	114	94
2	1 1/2	151	151	151	151	151	151	151	118	97
1 1/2	2	275	275	275	275	275	275	275	275	252
2	2	365	368	368	368	368	368	368	318	273
2	2 1/2	533	533	533	533	533	533	533	533	533

## Gas Pipe Specification

### NATURAL GAS SUPPLY PIPING

Pipe size	Cubic Feet of Natural Gas											
	Length	10'	20'	30'	40'	50'	60'	70'	80'	90'	100'	125'
1/2"	174	119	96	82	73	66	61	56	53	50	44	
3/4"	363	249	200	171	152	138	127	118	111	104	93	
1"	684	470	377	323	286	259	239	222	208	197	174	
1 1/4"	1404	965	775	663	588	532	490	456	428	404	358	
1 1/2"	2103	1445	1161	993	880	798	734	683	641	605	536	
2"	4050	2784	2235	1913	1696	1536	1413	1315	1234	1165	1033	
2 1/2"	6455	4437	3563	3049	2703	2449	2253	2096	1966	1857	1646	
3"	11412	7843	6299	5391	4778	4329	3983	3705	3476	3284	2910	
3 1/2"	16709	11484	9222	7893	6995	6338	5831	5425	5090	4808	4261	
4"	23277	15998	12847	10995	9745	8830	8123	7557	7091	6698	5936	

Based on 0.60 specific gravity for natural gas at 0.5 "W.C. pressure drop DOE standard is 1100 BTU per cubic ft. of natural gas

### PROPANE GAS SUPPLY PIPING

Pipe size	KBTU of Propane Gas													
	Length	10'	20'	30'	40'	50'	60'	70'	80'	90'	100'	125'	150'	200'
1/2"	276	190	153	130	115	104	97	90	84	79	70	64	56	
3/4"	568	394	316	268	238	218	197	186	174	163	147	133	112	
1"	1072	733	591	505	449	410	379	347	323	308	276	253	213	
1 1/4"	2206	1497	1213	1040	914	835	772	725	678	631	567	511	440	
1 1/2"	3308	2300	1859	1560	1418	1276	1182	1087	1024	977	867	788	676	
2"	6222	4332	3466	2993	2647	2395	2206	2048	1922	1812	1607	1496	1260	

Based on 11 "W.C. supply pressure

## Unit Clearance

MCU for Eternal is designed to position the units closely together; however, the units should be spaced at least 1ft apart to allow sufficient clearance for piping and wiring. The wiring between units can be stretched no more than 3ft. Only CAN-Bus wire supplied by Grand Hall can be used to network the units and no other extension wires can be used.

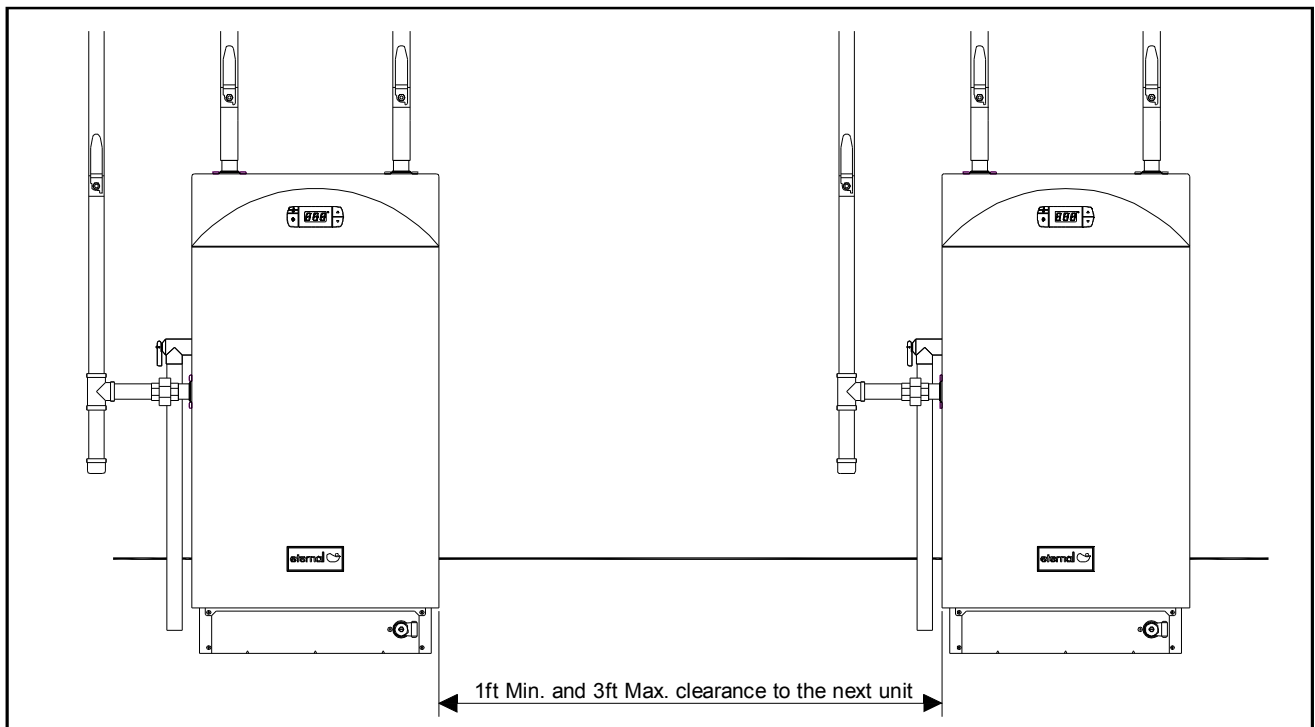



## Power Supply Schematic Diagram

Operating as a single unit, Eternal consumes less than 1A current, and the power supplied to the unit can be on as low as 2A capacity. However, when multiple Eternals are used together, power supply requirement is significantly increased.

Proper power supply design is important to ensure the safe operation of Eternal. When multiple units are used, the electrical supply needs to increase in capacity. Calculate by the below formula:

**# of units installed X 2A per unit = Total Amperage**

For example, for 16 units, 32A circuit is needed to supply power to the water heaters.

We recommend AWG #8 wiring for main power supply and AWG #16 at the sockets with no more than 2 Eternal water heaters plugged into each socket. All units should be on the same breaker switch so that the entire group can be reset easily if needed.

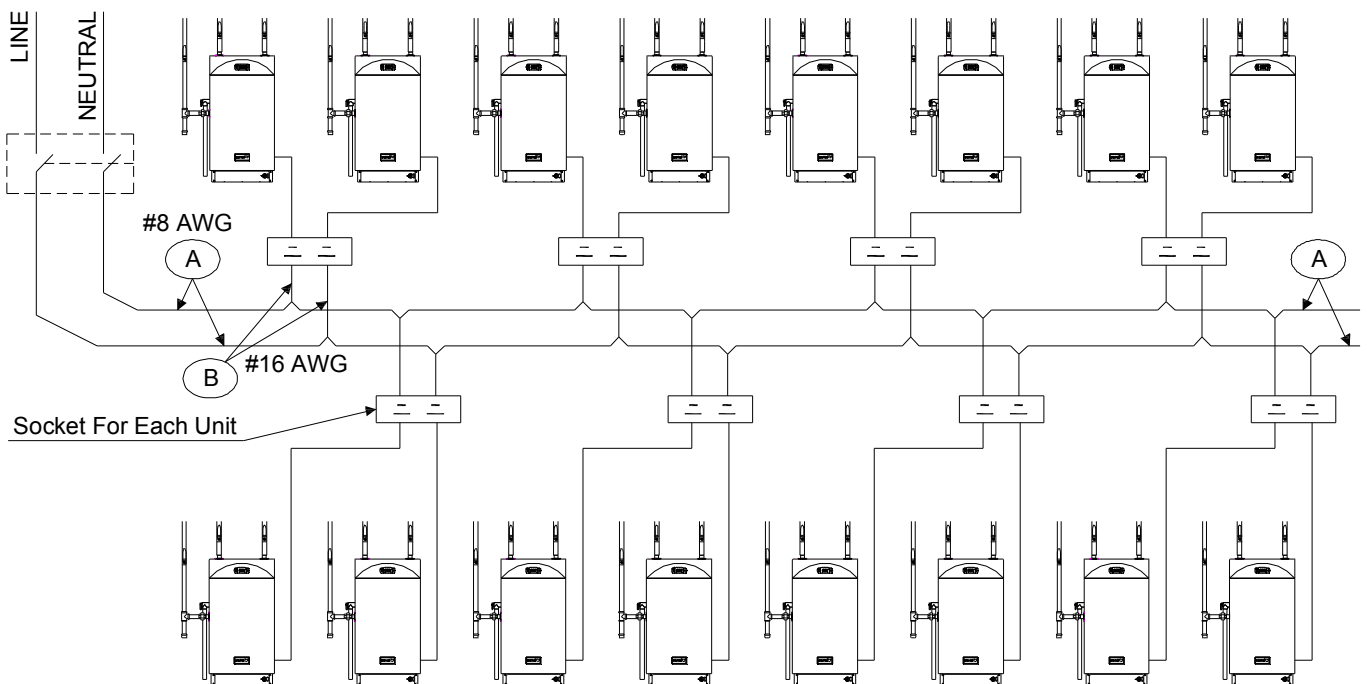

## Multiple Units Used in Recirculation and Heating Applications

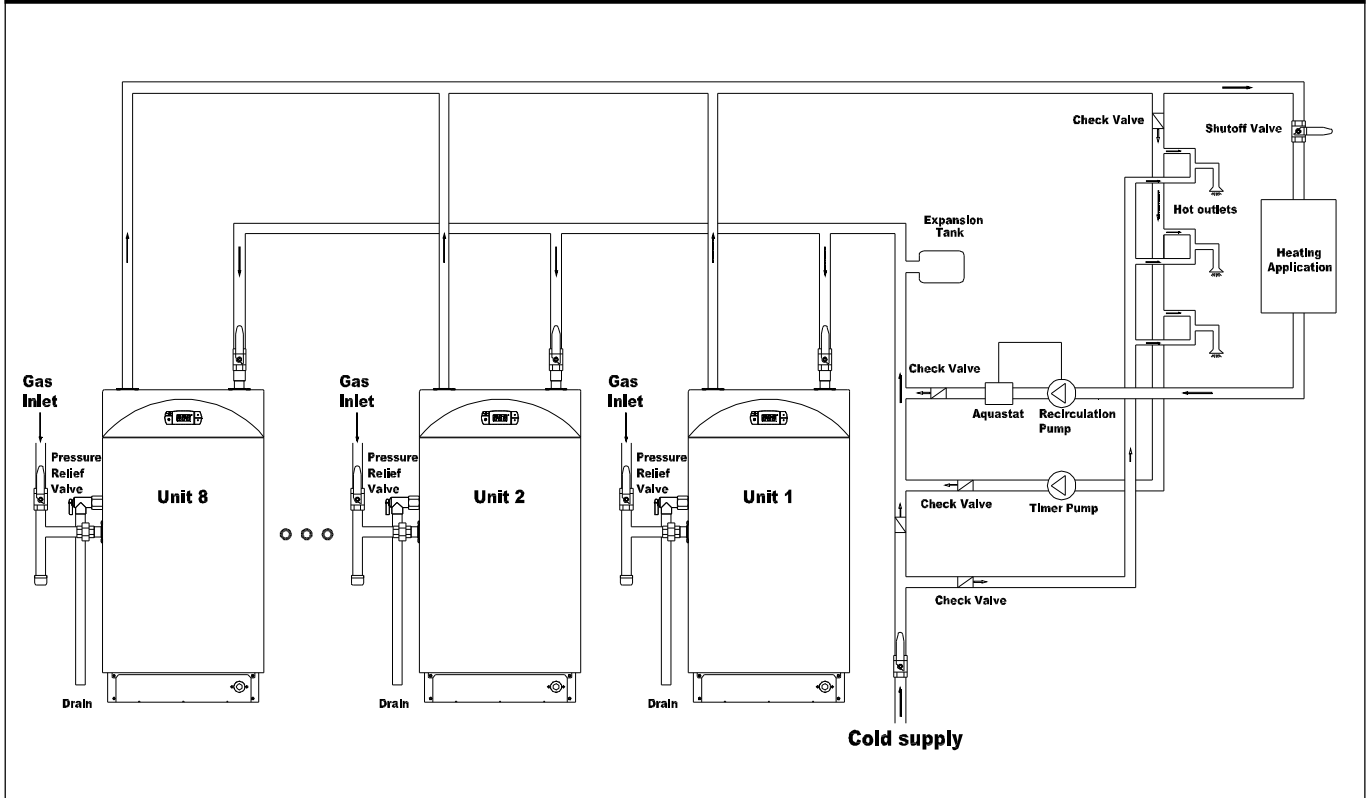

## Multiple Units Used with pre-Heater, i.e. Solar

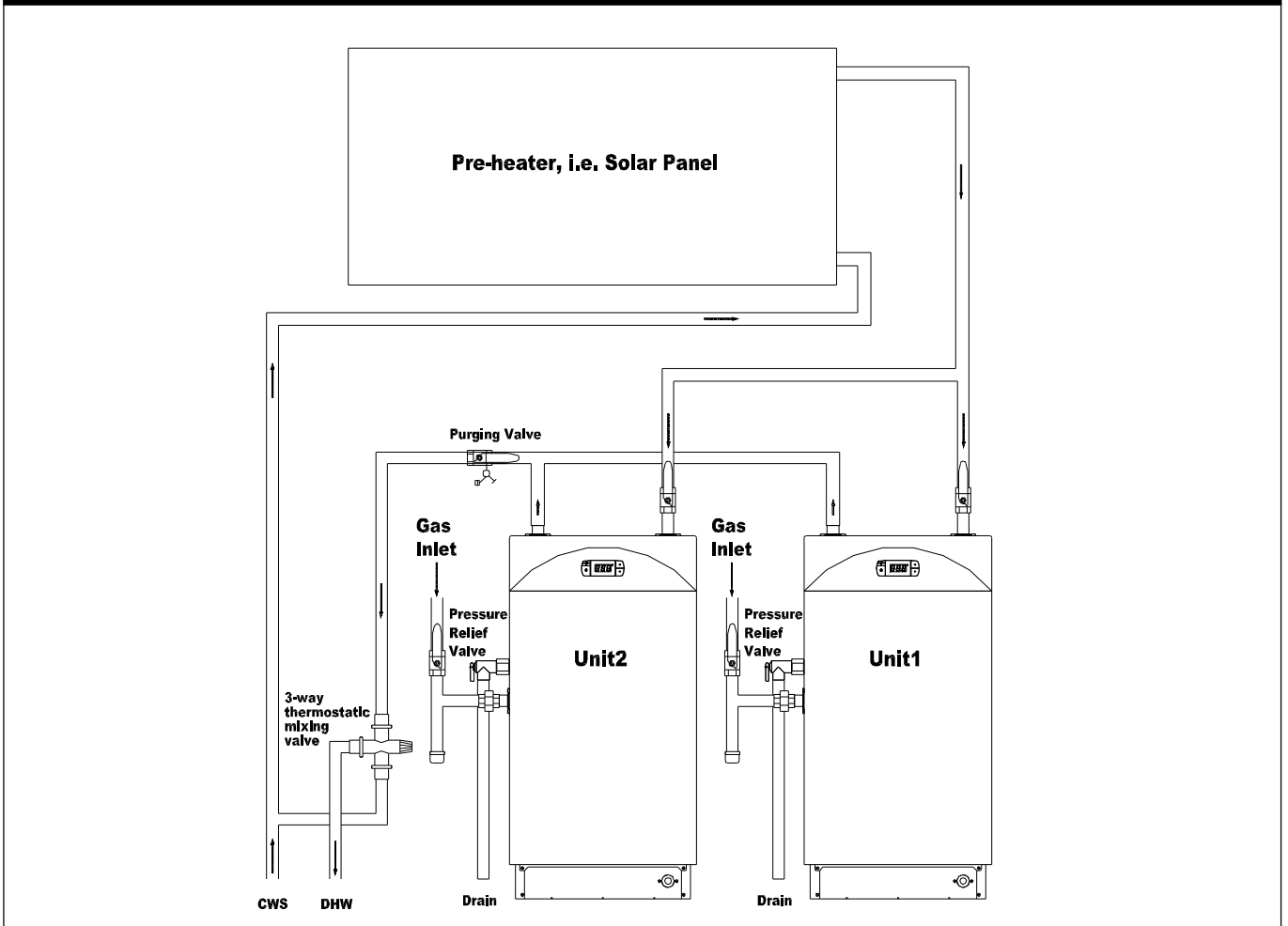

These diagrams are for reference as basic guides. Each installation should be engineered properly and compliant to Local and State Codes.

## Multiple Units Used with a Storage Tank

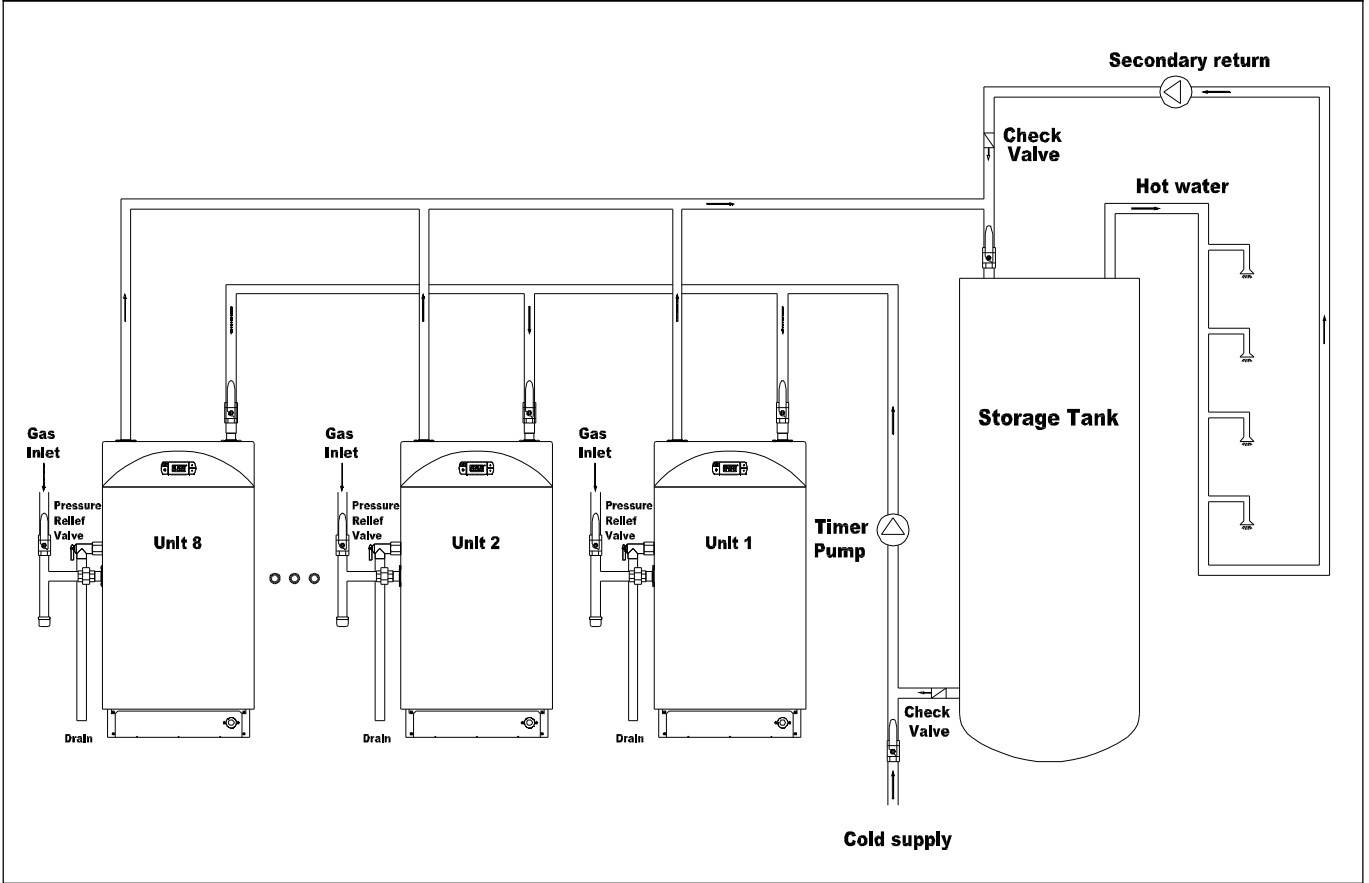

## Recirculation with Multiple Units

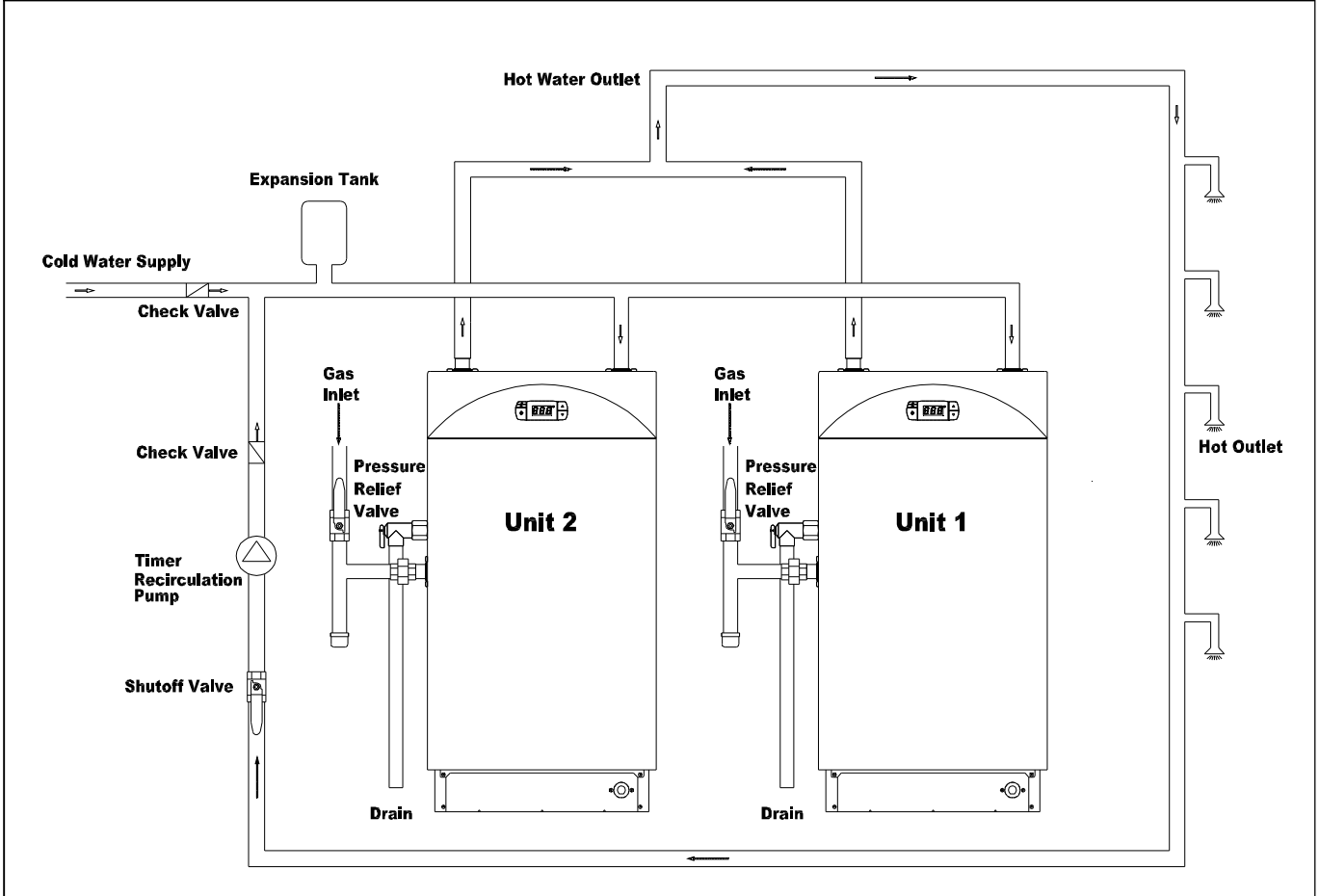

These diagrams are for reference as basic guides. Each installation should be engineered properly and compliant to Local and State Codes.

# 16 Units Manifold Connection

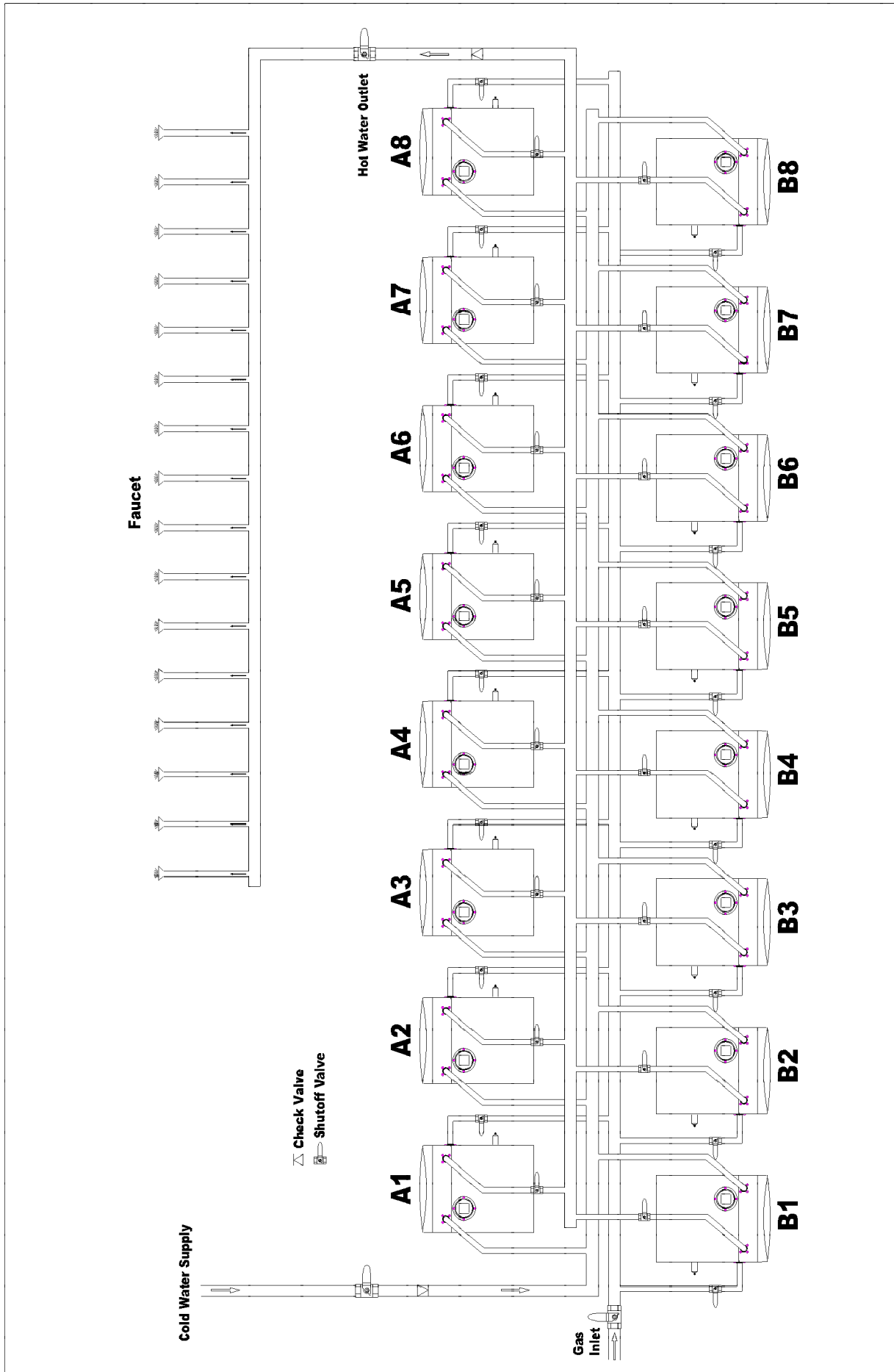

These diagrams are for reference as basic guides. Each installation should be engineered properly and compliant to Local and State Codes.

## Unique Unit Identification Number

All units networked need to be assigned unique ID numbers. For example, if 3 units are used, the first unit should be assigned #1 by pushing Dipswitches 1,2,3 and 4 to OFF position. The second unit should be assigned #2 by pushing Dipswitch 1 to ON position while leaving the rest in OFF position. The third unit should be assigned #3 by pushing Dipswitch #2 to ON position while leaving the rest in OFF position.

If two units are assigned the same ID# the network will not recognize the units correctly.

How many units installed	Identification
2 units	#1, #2
3 units	#1, #2, #3
4 units	#1, #2, #3, #4
5 units	#1, #2, #3, #4, #5
6 units	#1, #2, #3, #4, #5, #6
7 units	#1, #2, #3, #4, #5, #6, #7
8 units	#1, #2, #3, #4, #5, #6, #7, #8
9 units	#1, #2, #3, #4, #5, #6, #7, #8, #9
10 units	#1, #2, #3, #4, #5, #6, #7, #8, #9, #10
11 units	#1, #2, #3, #4, #5, #6, #7, #8, #9, #10, #11
12 units	#1, #2, #3, #4, #5, #6, #7, #8, #9, #10, #11, #12
13 units	#1, #2, #3, #4, #5, #6, #7, #8, #9, #10, #11, #12, #13
14 units	#1, #2, #3, #4, #5, #6, #7, #8, #9, #10, #11, #12, #13, #14
15 units	#1, #2, #3, #4, #5, #6, #7, #8, #9, #10, #11, #12, #13, #14, #15
16 units	#1, #2, #3, #4, #5, #6, #7, #8, #9, #10, #11, #12, #13, #14, #15, #16

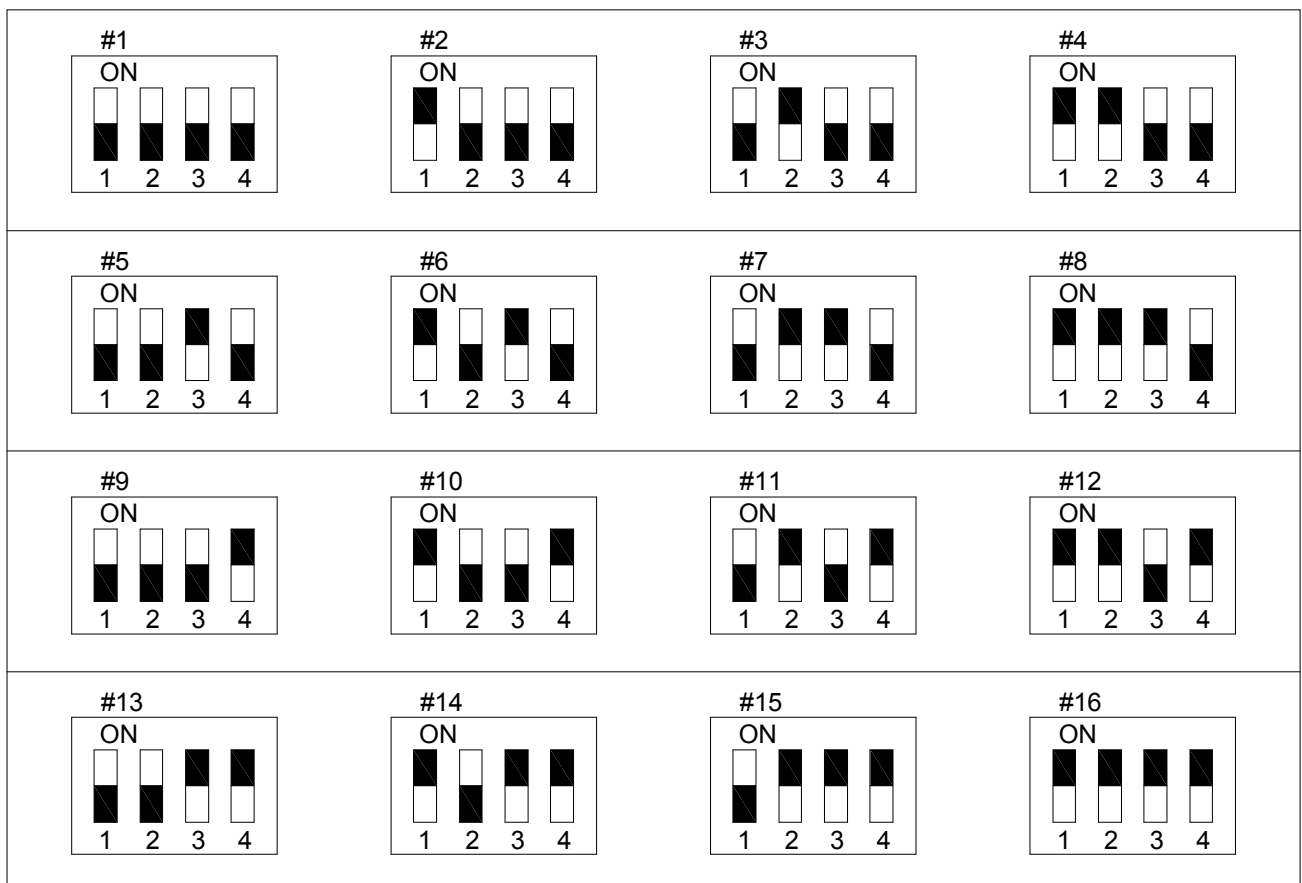

## Termination Setting

MCU utilizes CAN-Bus protocol which requires physical end units to be assigned “termination” status. For example, in a 2 unit application, unit ID1 and ID2 would both need to be electronically terminated since they are both on physical ends of the network. Another example using a 5 unit application, unit ID1 and ID5 would need to be electronically terminated.

To electronically terminate the end units in a group, locate the 8-button Dipswitch on the MCU module and push Dipswitch #8 to ON position.

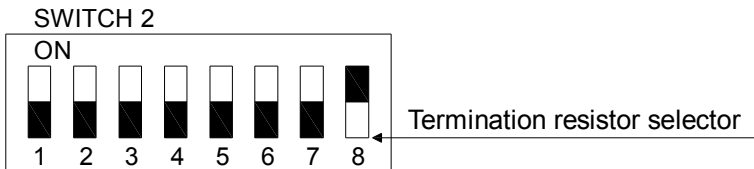

## MCU Operational Sequence Flow Chart

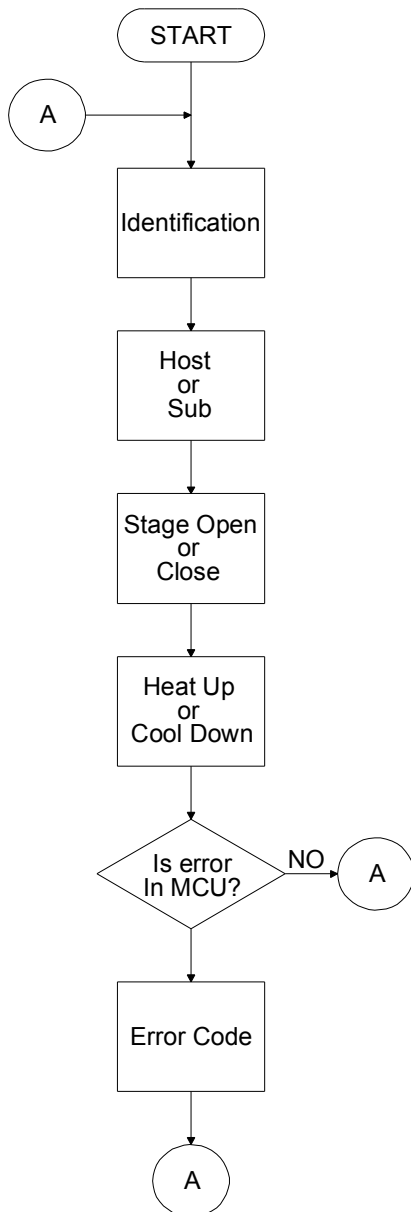

**Identification** - You can see the assigned unit ID# on the MCU module during this sequence.

**Host or Sub - "Ho" or "Su"** : This sequence displays the current Host unit in the group. The host unit is the first unit to fire when demand for hot water is detected. MCU will automatically reassign the role of Host to other Sub units every 24 hours.

**Staging Valve Open or Close** - This sequence will display whether the Staging Valve is open or closed.

**Heat Up or Cool Down** - Not all units in MCU configuration will keep hot water stored. This sequence will display which units are holding hot water reserve.

**Error Codes:**

- E1: Staging Valve is disconnected / Remedy: Check wiring between MCU and Staging Valve.
- E2: Staging Valve initialization error / Remedy: Replace Staging Valve.
- E3: No Sub units detected by Host / Remedy: Reset all units and make sure all units are properly configured and wired.
- E4: CAN-Bus communication error / Remedy: Reset all units and make sure all units are properly configured and wired.

## Grand Hall Limited Warranty

Grand Hall will warrant to the ORIGINAL PURCHASER of this MCU Kit that it will be free of defects in material and workmanship for set period below from the date of purchase when installed and operated in a single-family residence in accordance with the instructions in the manual and all local/state/federal codes.

### **MCU Kit - 3 Years Limited Warranty when initially installed together as part of Eternal Hybrid Water Heater.**

Grand Hall will require reasonable proof of your date of purchase. Save your receipt in case it is required as proof of purchase.

This Limited warranty is limited to repair or replacement of parts, at Grand Hall's option that proved to be defective under normal residential use utilizing potable water.

Grand Hall may require the return of defective parts for examination before issuing replacement parts or repairs. If you are required to return defective parts, transportation charges must be prepaid.

No returns will be accepted without prior authorization from Grand Hall.

Upon examination and to Grand Hall's satisfaction, if the original part is proven defective Grand Hall may approve your claim and elect to replace such parts without charge. You are responsible for shipping charges of such replacement parts.

This Warranty does not cover any failures or operating difficulties due to accident, abuse, misuse, alteration, misapplication, vandalism, improper installation, maintenance or service, as set out in this Operator's Manual.

Deterioration or damage due to severe weather conditions such as hail, hurricane, earthquakes, tsunamis, tornadoes, Acts of God or terrorism, discoloration due to exposure to chemicals either directly or in the atmosphere, is not covered by this Limited Warranty.

If service from authorized personnel is necessary to perform any work, you will be responsible for all labor charges outside of labor warranty period.

All replacement parts will carry out the remainder of warranty on the original parts.

### **To Obtain Warranty**

**Call 1-866-946-1096**

**8am - 4:30pm CST**

### **Warranty Restrictions**

- This warranty applies only when the water heater is used in the United States and Canada.
- This warranty gives you specific legal rights, and you may also have other rights which vary from state to state.

Manufacturer:

**Grand Hall Enterprise Co., Ltd.**

9th Fl., No.298, Rueiguang Rd., Neihu,

Taipei, Taiwan (114)