

LD Series

Installation Manual



The LD Series Infrared Tube Heater is a positive pressure, two stage radiant heater system. This manual provides specific information related to the LD Series model. All persons involved with the installation, operation and maintenance of the heater system must read and understand the information in this manual.

⚠ WARNING



Improper installation, adjustment, alteration, service or maintenance can cause property damage, injury or death. Read the installation, operation and maintenance instructions thoroughly before installing or servicing this equipment.

This heater **must** be installed and serviced by trained gas installation and service personnel only. Failure to comply could result in personal injury, asphyxiation, death, fire or property damage.



Do not store or use gasoline or other flammable vapors and liquids in the vicinity of this or any other appliance.

In locations used for the storage of combustible materials, signs **must** be posted to specify the maximum permissible stacking height to maintain the required clearances from the heater to the combustibles. Signs must either be posted adjacent to the heater thermostats or in the absence of such thermostats, in a conspicuous location.



Do not use this heater in indoor living or sleeping quarters, ect.! Installation of a tube heater system in residential indoor living spaces may result in property damage, serious injury, asphyxiation or death.

For Your Safety

If you smell gas:

- Do not try to light any appliance.
- Do not touch any electrical switch.
- Do not use any phone in your building.
- Immediately call your gas supplier from a neighbor's phone.
- Follow the gas supplier's instructions.
- If you cannot reach your gas supplier, call the fire department.

Keep these instructions for future reference.

Contents

1.0 Introduction	3
Overview	3
Specifications	3
Safety Signs and Labels	4
2.0 Safety	6
Warning Symbols	6
Applications	6
Standards, Certifications and Government Regulations	7
Clearance to Combustibles	8
3.0 Installation	10
Design Considerations and Prechecks	10
Recommended Mounting Heights	11
Hanger Placement and Suspension	12
Radiant Tube Assembly	16
Optional Elbow or U-Bend Accessory Configuration	17
Burner Control Box Suspension	19
Reflector Assembly	20
Baffle Assembly and Placement	22
Final Heater Assembly	23
Venting	24
Sidewall Venting	25
Rooftop Venting	26
Optional Unvented Operation	28
Combustion Air Requirements	28
Gas Supply	30
Electrical Requirements and Diagrams	33
4.0 Operation	37
Lighting Procedures	37
Sequence of Operation	38
Diagnostics	39
5.0 Maintenance	40
Troubleshooting Guide	40
Heater Components and Parts List	44
Maintenance Checks	46
Limited Warranty	47
Kit Contents	48

1.0 Introduction

Overview

The intent of this manual is to provide information regarding safety, design guidelines, installation, operation and maintenance of the tube heater. You must read and understand the instructions and all safety warnings before installing the tube heater.

Heater Components

Prior to installation, verify that the heater's gas type and voltage (as listed on the rating plate) match that of your application. Also verify that you have received all heater contents included with your tube heater. Reference page 48 for a list of the kit contents for your model heater. Materials not included in the heater kit contents (e.g., screws, vent material, terminals, etc.) are the responsibility of the installer. Notify your product representative or Detroit Radiant Products of any discrepancy or missing kit contents prior to installing unit.

Specifications

Chart 1.1 • LD Series Specifications

Model Number	Gas Type (select one)	BTU/H (High Fire)	BTU/H (Low Fire)	Straight Length	U-Tube Length	Standard Weight (lbs.)	Recommended Mounting Height**	Combustion Chamber (Black Coated)	Radiant Emitter Tube(s) (Black Coated)	Residential Certification [^]
LD-10-40	N or LP	40,000	28,000	12'-1"	N/A	70 lbs.	10' to 14'	Titan	Alum	No
LD-15-40	N or LP	40,000	28,000	16'-10"	N/A	85 lbs.	8' to 13'	Titan	Alum	Yes
LD-15-50	N or LP	50,000	35,000	16'-10"	N/A	85 lbs.	10' to 15'	Titan	Alum	No
LD-20-40	N or LP	40,000	28,000	21'-10"	13'-0"	100 lbs.	8' to 13'	Titan	Alum	Yes
LD-20-50	N or LP	50,000	35,000	21'-10"	13'-0"	100 lbs.	9' to 15'	Titan	Alum	No
LD-30-50*	N or LP	50,000	35,000	31'-7"	17'-8"	120 lbs.	9' to 14'	Titan	Alum	Yes

* Model requires DB-5EA-SUB optional accessory package when installing in a 'U' configuration (P/N: DB-TF1B).

** Recommended mounting heights are provided as a guideline. Actual conditions may dictate variations from this data. Optional protective guard (P/N: PG) is required when mounting below 8-ft.

[^] Certified models may be installed in attached residential garages/workshops.

Titan = Black coated titanium stabilized aluminized steel.

Alum = Black coated aluminized treated steel.

⚠ WARNING



Improper installation, adjustment, alteration, service or maintenance can cause property damage, serious injury or death. Read and understand, the installation, operating and maintenance instructions thoroughly before installing or servicing this equipment. Only trained, qualified gas installation and service personnel may install or service this equipment.

Safety Signs and Labels

Safety warning labels must be maintained on the tube heater and should be replaced if they become illegible. Contact either your local distributor or the product manufacturer for obtaining replacement signs or labels.

It is important to provide warnings to alert individuals to potential hazards and safety actions. In locations used for the storage of combustible materials, ANSI Z83.20b and CSA 2.34 require a placard to be posted “specifying the maximum permissible stacking height to maintain the required clearances from the heater to the combustibles” near the heaters thermostat or in absence of such thermostats in a conspicuous location. Contact Detroit Radiant Products Co. or an authorized dealer for Clearance Safety Limit Signs or for Clearance Safety Limit Tags (one tag is provided with each heater).

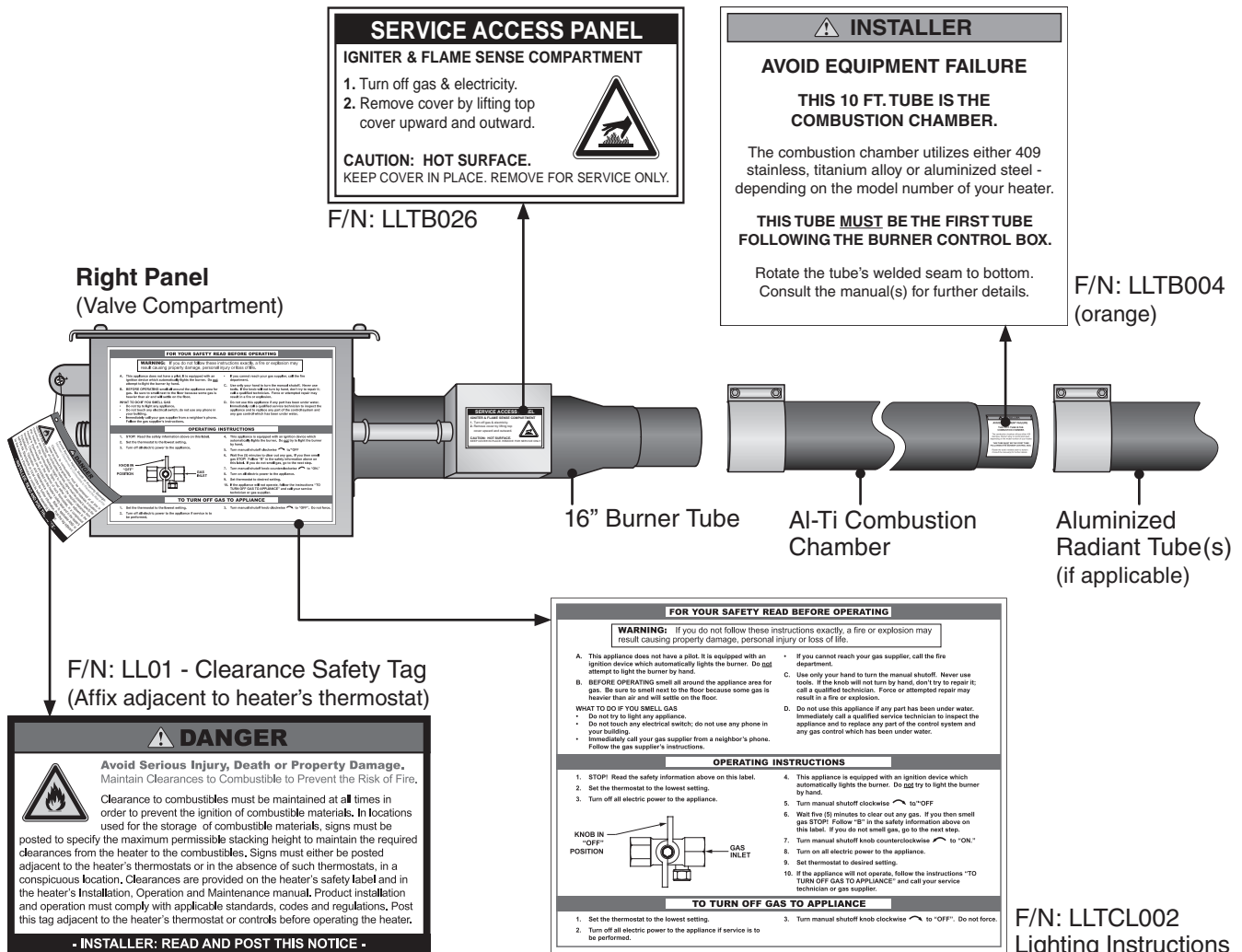

2.0 Safety

⚠ WARNING



Improper installation, adjustment, alteration, service or maintenance can cause property damage, serious injury or death. Read and understand, the installation, operating and maintenance instructions thoroughly before installing or servicing this equipment. Only trained, qualified gas installation and service personnel may install or service this equipment.

Warning Symbols

Safety is the most important consideration during installation, operation and maintenance of the tube heater. You will see the following symbols and signal words when there is a hazard related to safety or property damage.

⚠ WARNING

Warning indicates a potentially hazardous situation which, if not avoided, could result in death or injury.

⚠ CAUTION

Caution indicates a potentially hazardous situation which, if not avoided, could result in minor or moderate injury.

NOTICE

Notice indicates a potentially hazardous situation which, if not avoided, could result in property damage.

⚠ CAUTION

Children and adults should be alerted to the hazards of high surface temperatures and should stay away to avoid burns or clothing ignition.

Young children should be carefully supervised when they are in the same space as the heater.

Clothing or other flammable materials should not be hung from the heater, or placed on or near the heater.

Any guard or other protective device removed for servicing the heater must be replaced prior to operating the heater.

Installation and repair should be done by a qualified service person. The heater should be inspected before use and at least annually by a qualified service person. More frequent cleaning may be required as necessary. It is imperative that the control compartment, air passageways and burner(s) of the heater be kept clean.

Applications

This is **not** an explosion proof heater. No tube heater may be used in a Class 1 or Class 2 Explosive environment. Consult your local Fire Marshall, insurance carrier and other authorities for approval if the proposed installation is in question.

Commercial / Industrial Applications

Unless otherwise indicated, tube heaters are designed and certified for use in industrial and commercial buildings, such as warehouses, manufacturing plants, aircraft hangars and vehicle maintenance shops. For maximum safety the building must be evaluated for potential problems before installing the heating system. A critical safety factor to consider before installation is the clearance to combustibles.

Residential Applications

Only select LD Series models are Design Certified under CSA Requirements for residential radiant tube heaters (No. 7-89). Not for use in the residential indoor living areas or sleeping quarters.

⚠ WARNING

Not For Use in Indoor Living Spaces. Installing this unit in residential indoor living spaces or sleeping quarters, such as bedrooms or basements, may result in property damage, serious injury or death.

Standards, Certifications and Government Regulations

Installation of this tube heater must conform with all applicable local, state and national specifications, regulations and building codes. Contact the local building inspector and/or fire Marshall for guidance.

In the absence of local codes, the installation must conform to the latest edition of:

United States: National Fuel Gas Code, ANSI Z223.1 (NFPA 54).

Canada: CAN/CGA B149.1 and .2, Canadian Electrical Code C22.1

Public Garages:

This heater must be installed in accordance with the latest edition of the Standard for Parking Structures, ANSI/NFPA 88A or the Code for Motor Fuel Dispensing Facilities and Repair Garages ANSI/NFPA 30A. In Canada, refer to CAN/CGA B149.1 and B149.2.

- Heaters must not be installed less than 8 ft. (2.4 m) above the floor. Minimum clearances to combustibles must be maintained from vehicles parked below the heater.
- When installed over hoists, minimum clearances to combustibles must be maintained from the upper most point of objects on the hoist.

Aircraft Hangars:

This heater must be installed in accordance with the latest edition of the Standard for Aircraft Hangars, ANSI/NFPA 409. In Canada, refer to CAN/CGA B149.1 and B149.2.

- In aircraft storage and servicing areas, heaters shall be installed at least 10 ft. from above the upper surface of wings or of the engine enclosures of the highest aircraft that may be housed in the hangar. The measurement shall be made from the wing or engine enclosure, whichever is higher from the floor, to the bottom of the heater.
- In areas adjoining the aircraft storage area (e.g., shops, offices) the bottom of heaters shall be installed no less than 8 ft. (2.4 m) above the floor.
- Suspended or elevated heaters shall be located in spaces where they shall not be subject to damage by aircraft, cranes, movable scaffolding or other objects.

Provisions shall be made to assure accessibility to suspended tube heaters for recurrent maintenance purposes.

Clearance to Combustibles

⚠ WARNING



Placement of explosive objects, flammable objects, liquids and vapors close to the heater may result in explosion, fire, property damage, serious injury or death. Do not store or use explosive objects, liquids and vapor in the vicinity the heater.

Hazards:

For maximum safety the building must be evaluated for hazards before installing the heating system. Examples include, but are not limited to:

- Gas and electrical lines
- Combustible and explosive materials
- Chemical storage areas
- Areas of high chemical fume concentrations
- Provisions for accessibility to the heater
- Adequate clearances around air openings
- Combustion and ventilating air supply
- Vehicle parking areas
- Vehicles with lifts or cranes
- Storage areas with stacked materials
- Lights
- Sprinkler heads
- Overhead doors and tracks
- Dirty, contaminated environment

A critical safety factor to consider before installation is the clearances to combustibles. **Clearance to combustibles** is defined as the minimum distance you must have between the tube surface, or reflector, and the combustible item. Considerations must also be made for moving objects around the tube heater. The following is a partial list of items to maintain clearances from:

Combustible items:

- Wood
- Paper
- Fabric
- Chemicals
- Paint
- Parked vehicles
- Gasoline
- Storage racks

Moving Objects:

- Overhead doors
- Vehicle lifts
- Cranes
- Hoists

When installing the tube heating system, the minimum clearances to combustibles for your Series tube heater and system configuration must be maintained. These distances are shown in Chart 1.1 on page 9 and on the burner control box. If you are unsure of the potential hazards, consult your local fire marshall, fire insurance carrier or other qualified authorities on the installation of gas fired tube heaters for approval of the proposed installation.

In locations used for the storage of combustible materials, signs must be posted to specify the maximum permissible stacking height to maintain the required clearances from the heater to the combustibles. Signs must either be posted adjacent to the heater's thermostat or in a conspicuous location.

⚠ WARNING



Failure to comply with the stated clearances to combustibles may result in personal injury, property damage and/or death.

Chart 1.1 • Clearance to Combustibles in Inches (see Figure 1.1 for Mounting Angles)

Model Number	Mounting Angle*	Sides			
		Front	Behind	Top	Below
40,000 BTU/H MODELS					
LD (10, 15, 20) - 40 [N, P] with 1 side shield with 2 side shields 20 ft. from burner	0°	15	15	6	45
	45°	58	8	10	45
	0°	42	8	6	45
	0°	20	20	6	45
	0°	N/A	N/A	N/A	N/A
50,000 BTU/H MODELS					
LD (15, 20, 30) - 50 [N, P] with 1 side shield with 2 side shields 20 ft. from burner	0°	11	11	6	48
	45°	39	8	10	48
	0°	29	8	6	48
	0°	16	16	6	48
	0°	7	7	6	30

* Heaters mounted on an angle between 0° to 45° must maintain clearances posted for 0° or 45°; whichever is greater.
NOTE: Use high BTU output when determining clearances. The minimum end clearance is 12 in.

Figure 1.1 • Mounting Angles

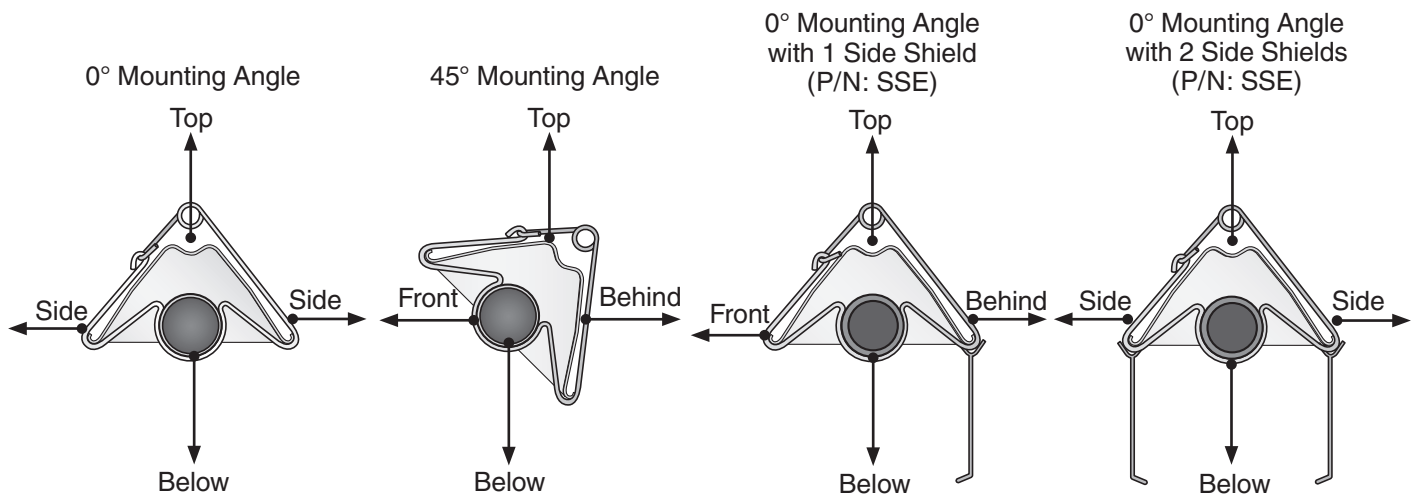

3.0 Installation

⚠ WARNING



Improper installation, adjustment, alteration, service or maintenance can cause property damage, serious injury or death.

Read and understand, the installation, operating and maintenance instructions thoroughly before installing or servicing this equipment.

Only trained, qualified gas installation and service personnel may install or service this equipment.

Design Considerations and Prechecks

Placement of infrared heaters is influenced by many factors. Aside from safety factors, considerations such as the number of heater or vent elbows that are allowed, maximum vent lengths, ducting of combustion air and combining exhaust vents are a few examples. All installation manuals, along with national, state, provincial and local codes, address these issues. It is critical that you read, understand and follow all guidelines and instructions.

To ensure a properly designed heating system, a layout should be developed for the correct placement of the burner control box, tubes, vents and combustion air intake ducts. Inspect and evaluate the mounting conditions, vent locations, gas supply and wiring.

When designing an infrared radiant heating system, consider the following:

- Has the building's heat loss been evaluated?
- Does the design meet the needs of the space?
- Have recommended mounting heights been observed?
- Have all clearance to combustible situations been observed?
- Is the supply (burner) end of the heater located where more heat is required?
- Is it best to offset the heaters and/or rotate the reflectors towards the heat zone?
- Are extra guards, side shields, 'U' or 'L' reflector covers required?
- Does the heater require outside fresh air for combustion?
- Is the environment harsh or contaminated (requiring outside air for combustion)?
- Are chemicals or vapors a concern (requiring outside air for combustion or additional ventilation)?

IMPORTANT: Fire sprinkler heads must be located at an appropriate distance from the heater. This distance may exceed the published clearance to combustibles as posted on the heater. Certain applications may require the use of high temperature sprinkler heads or relocation of the heaters.

Sprinkler systems containing propylene glycol or other flammable substances are not to be used in conjunction with this heater without careful consideration for and avoidance of potential fire or explosion hazards. For further information consult NFPA 13.

The effective infrared surface temperature of a person or object may be diminished with wind above 5 mph. The use of adequate wind barrier(s) may be required.

Chart 3.1 • Recommended Mounting Heights and Coverages

NOTE: This chart is provided as a guideline. Actual conditions may dictate variation from this data.

Model	BTU/H Output	Recommended Mounting Height (ft.)*	Coverage Area Straight Config. (LxW)	Coverage Area U-Tube Config. (LxW)	Distance Between Heaters (ft.) Dimension A	Distance Between Heater Rows (ft.) Dimension B	Maximum Distance Between Heaters and Wall (ft.) Dimension C
10 ft.	25,000	8' - 11'	20' x 12'	N/A	10' - 20'	20' - 40'	16'
	30,000	8' - 11'	20' x 12'	N/A	10' - 20'	20' - 40'	16'
	40,000	10' - 14'	20' x 12'	N/A	10' - 20'	20' - 40'	16'
15 ft.	40,000	8' - 13'	20' x 12'	N/A	10' - 20'	20' - 40'	16'
	50,000	10' - 15'	22' x 15'	N/A	20' - 30'	30' - 50'	18'
20 ft.	40,000	8' - 13'	20' x 13'	12' x 12'	10' - 20'	20' - 40'	16'
	50,000	9' - 15'	22' x 15'	12' x 12'	20' - 30'	30' - 50'	18'
30 ft.	50,000	9' - 14'	22' x 15'	15' x 15'	20' - 30'	30' - 50'	18'

Factory recommended mounting heights are listed as a guideline. If infrared heaters are mounted to low or to high, they may result in discomfort or lack of heat. Detroit Radiant Products Company generally recommends observing the recommended mounting heights to optimize comfort conditions. However, certain applications such as spot heating, freeze protection, outdoor patio heating or very high ceilings may result in the heaters being mounted outside of the factory recommended mounting heights.

* Optional protective guard (P/N: PG) is required when mounting below 8-ft.

Figure 3.3 • Mounting Height Dimensions • see chart 3.1 for dimensions

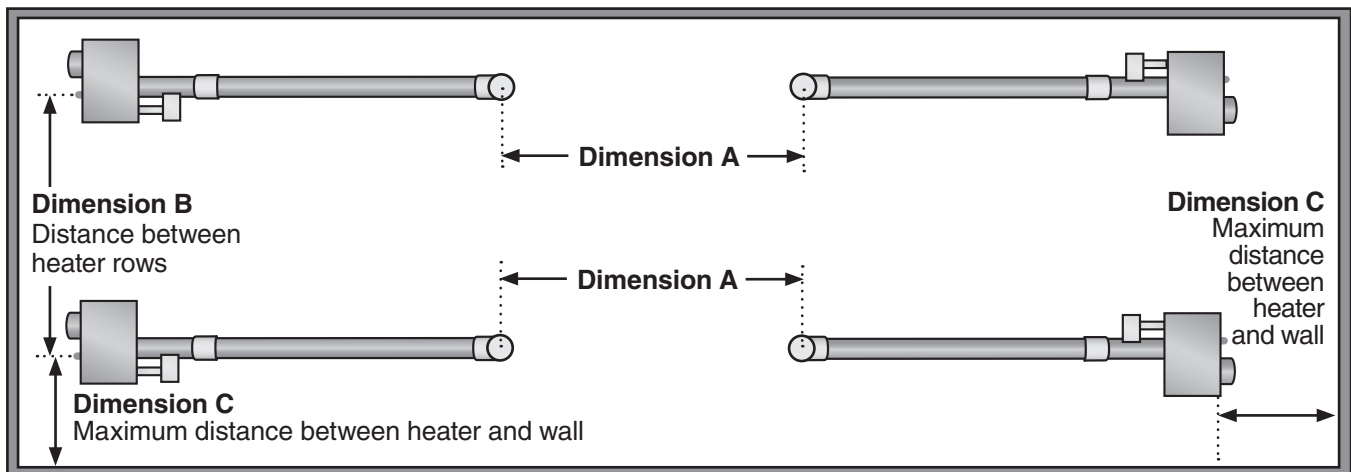

Note: Dimensions A, B & C are based upon heaters hung at the factory recommended mounting height.

Hanger Placement and Suspension

⚠ WARNING



Improper suspension of the tube heater may result in collapse and being crushed. Always suspend from a permanent part of the building structure that can evenly support the total force and weight of the heater.



Failure to maintain minimum clearance to combustibles may result in fire and/or explosion, property damage, serious injury or death. Always maintain minimum clearances and post clearance safety limit signs or the clearance safety tag where needed.

Suspension of the heater must conform to applicable codes referenced in the Safety section and these instructions.

- 1 Lay all radiant tubing out in the following order. Position tubes in approximate location (see Figure 3.4).
 - 10 ft. Titanium treated combustion chamber.
 - Radiant emitter tube(s).

Important! The 10 ft. titanium alloy treated combustion chamber must be placed as the first tube downstream of the burner control box. The combustion chamber has an orange identification sticker located on the swaged end of the tube.

- 2 Mark locations for hanging points.

NOTE: If the available hanging points do not allow for the recommended spacing then additional hangers (P/N: TP-1079) may be necessary.

- The spacing between the burner control box mounting brackets and the first hanger should be approximately 2'-4".
- The space between the first two hangers placed on the first tube, should be approximately 8'-10".
- The space between hangers thereafter, one per tube, should be approximately 9'-8".

Figure 3.4 • Heater Mounting Layout

NOTE: A sticker identifying the titanium treated combustion chamber(s) is located on the swaged end of the tube(s).

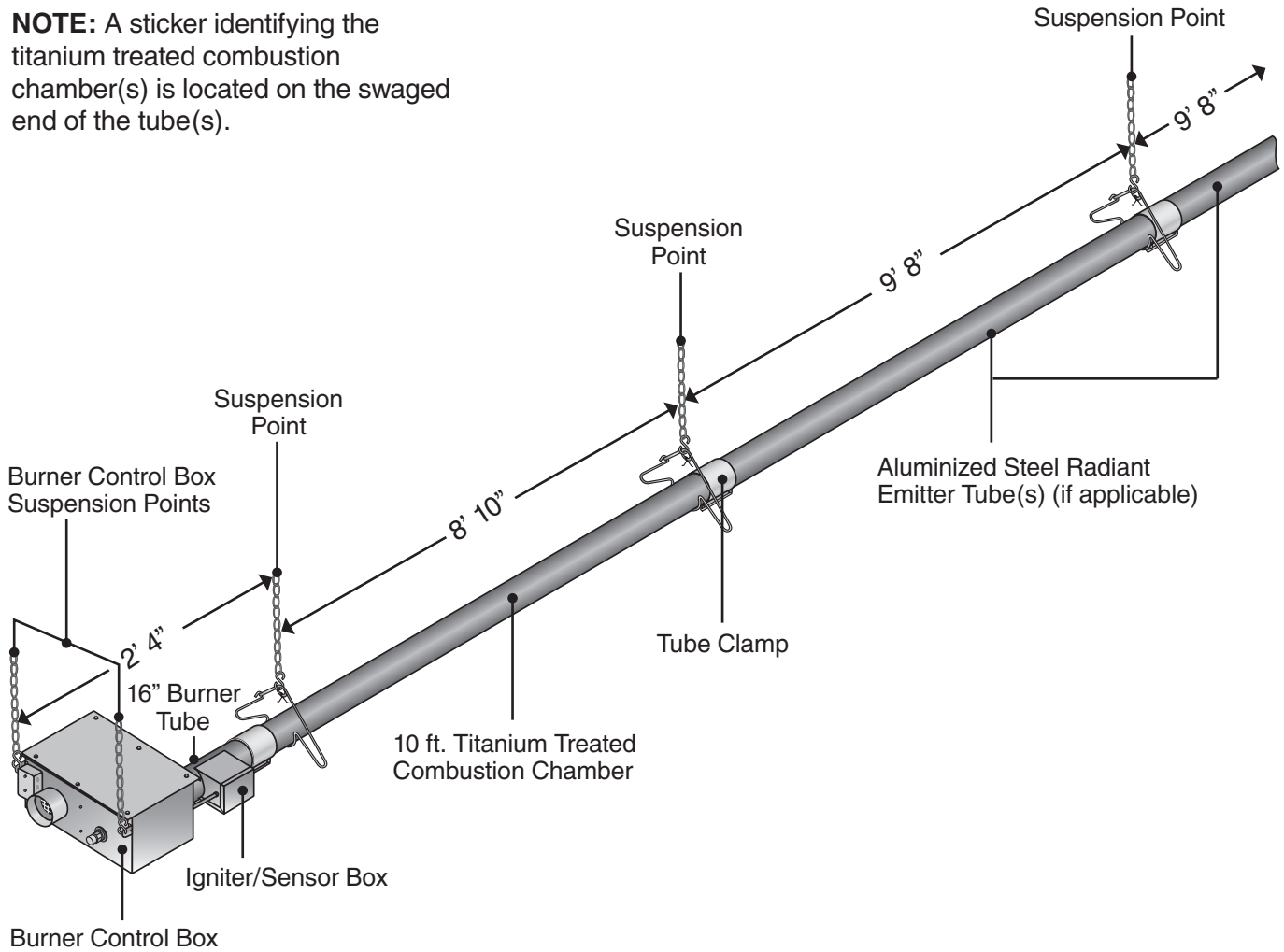

Chart 3.2 • Heater Mounting Requirements and Weights

Model	Dimension* Straight Configuration	Suspension Points	Control Box Stabilizer	Shipping Weight	Chain Set Qty. Straight	Chain Set Qty. w/TF1B	Optional Brass Knuckle (P/N: BK)	Optional Single Mount Bracket
10 ft.	12'-1" / 145"	2	2	70 lbs.	4	5	2	1
15 ft.	16'-10" / 202"	2	2	85 lbs.	5	6	3	N/A
20 ft.	21'-10" / 262"	3	2	100 lbs.	5	6	3	2
30 ft.	31'-7" / 379"	4	2	120 lbs.	6	7	4	N/A

* Refer to page 18 for U-bend configuration dimensions.

- 3 Prepare mounting surface, if necessary weld blocks, drill holes (see figure 3.5).
NOTE: The burner control box and radiant tubes should be in straight alignment and level.
- 4 Fasten beam clamp, screw hook or other type of suspension anchor to hanging point.
- 5 Attach and close S-hook (P/N: S-Hook) and #1 double-loop chain (P/N: THCS) to anchor. Check that it is securely attached. **NOTE:** Threaded rod and turnbuckles may be used.
- 6 Attach hangers to chains. Adjust chain lengths until radiant tubing is level and equal weight distribution is achieved. Chains must be straight up and down. Do not install chains at an angle as this can result in tube warpage or separation.

Figure 3.5 • Mounting the Hangers

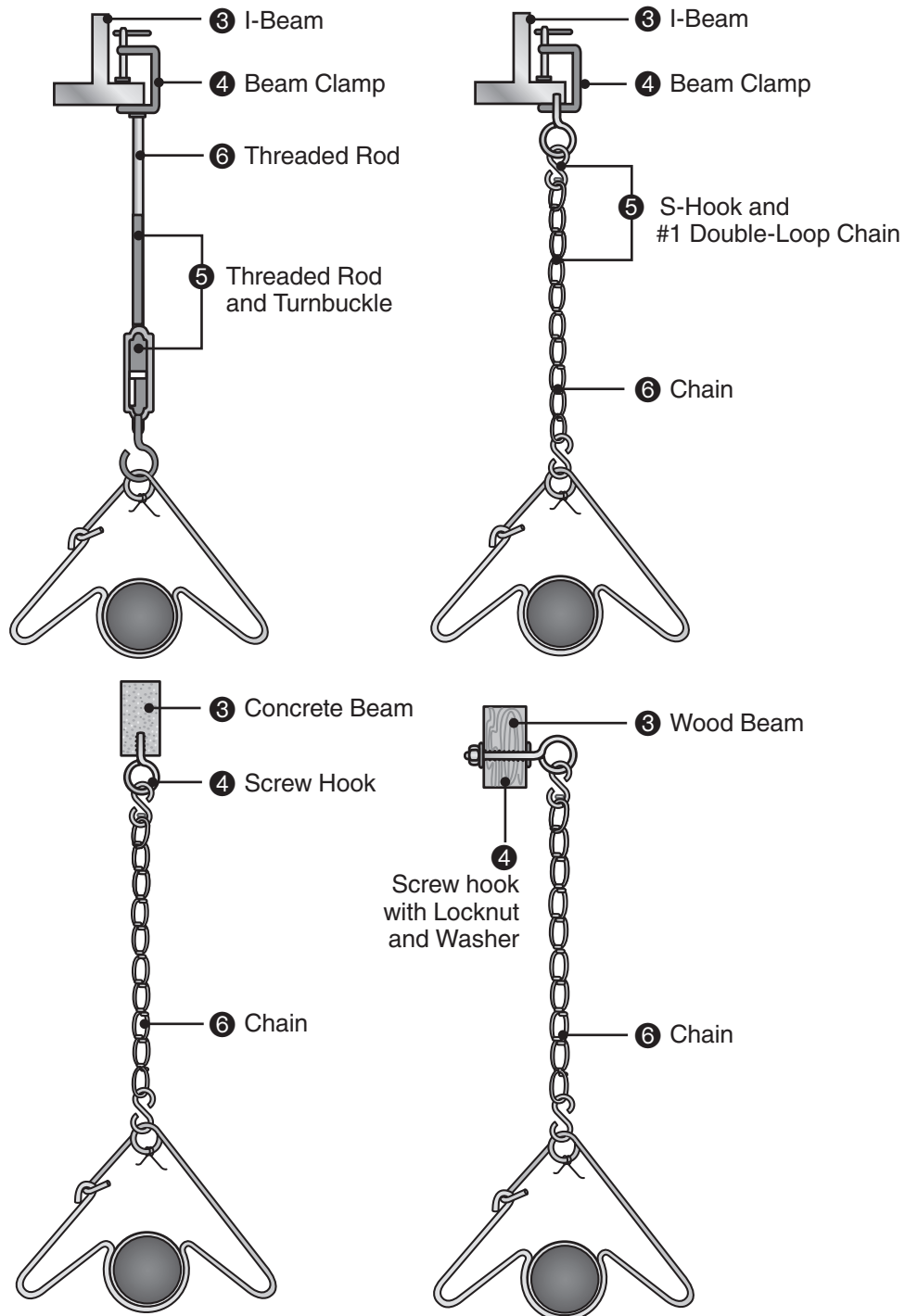
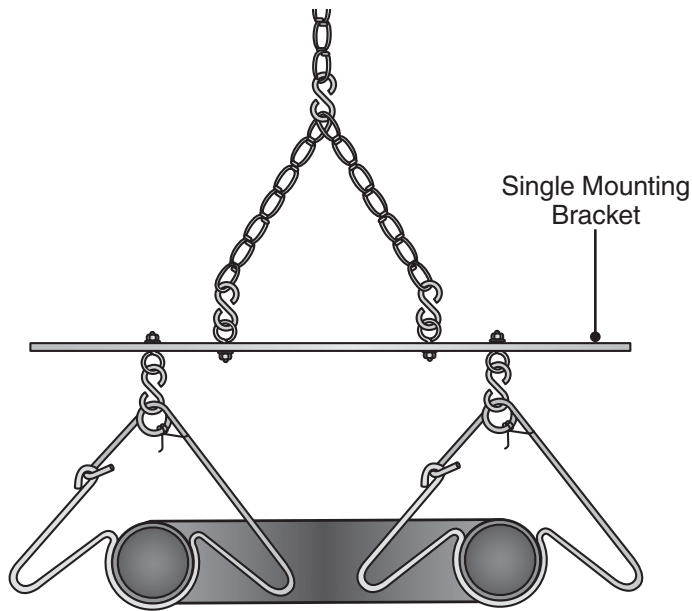
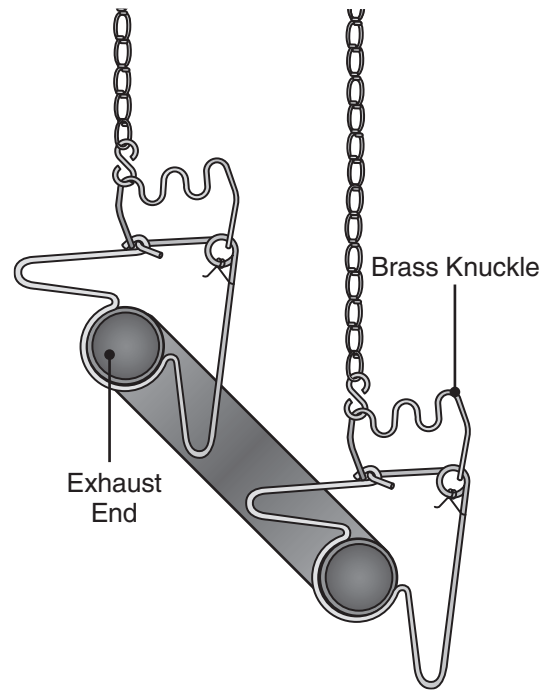

Figure 3.6 • U-Tube Hanger Mounting Options



U-Tubes can be mounted from a single suspension point using an optional Single Mounting Bracket (P/N: SMB) with five S-hooks and #1 double-loop chains.



U-Tubes can be mounted at a 15, 30 or 45 degree angle with two suspension points, using two optional Brass Knuckle (P/N: BK) fittings, #1 double-loop chains and S-hooks.

Figure 3.7 • Angled Hanger Mounting Options

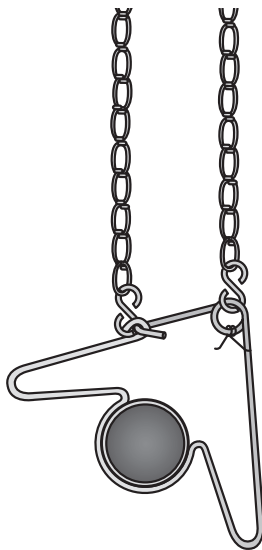

For 45 degree hanging angle use two S-hooks and two #1 double-loop chains.

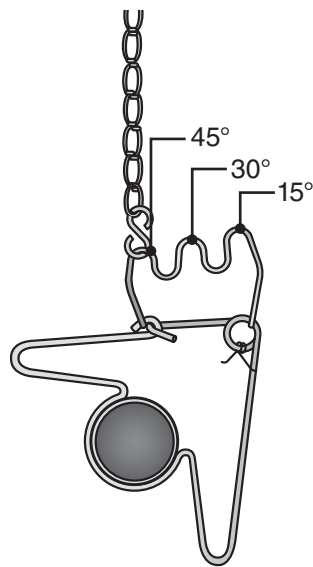

For variety of hanging angles, use an optional Brass Knuckle (P/N: BK) fitting with a #1 double-loop chain and S-hook.

Radiant Tube Assembly

To install the radiant tubes:

- 1 Place tubes in hangers with the welded seam facing downward and the swaged end of the tube towards the exhaust end of the heater system (see Figure 3.8).

Refer to page 23 for tube installation sequence.

Figure 3.8 • Attach Hangers

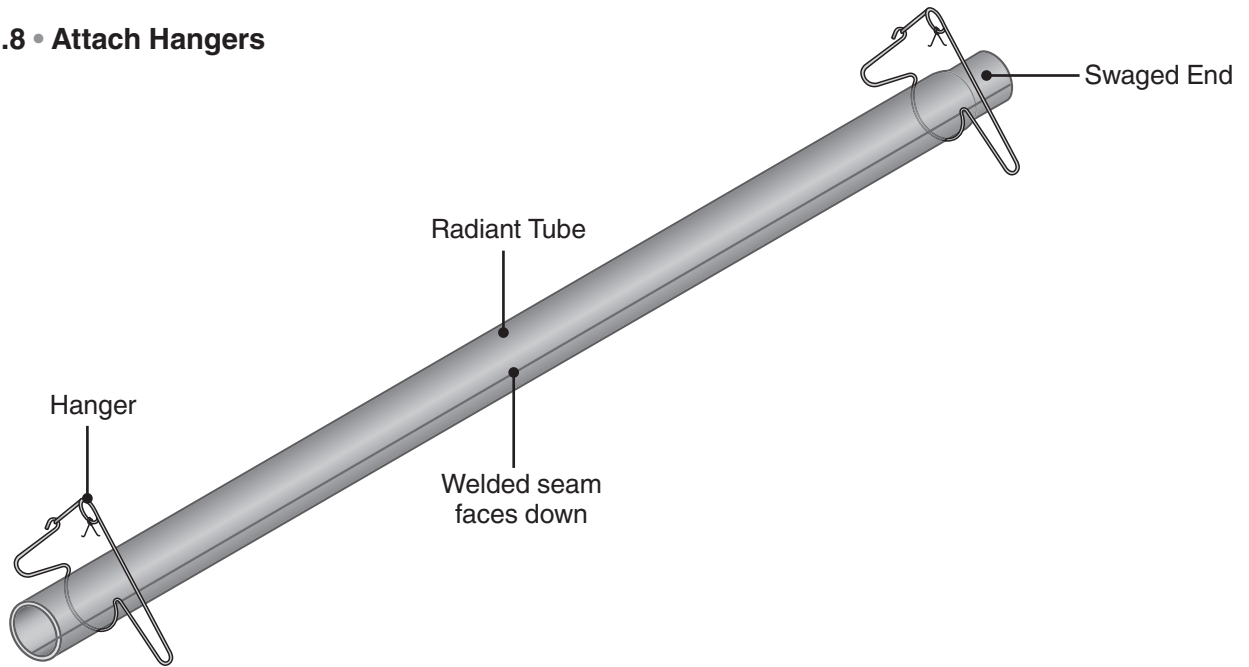

- 2 Slide tube clamps onto radiant tubes (see figure 3.9).

Figure 3.9 • Attach Tube Clamps

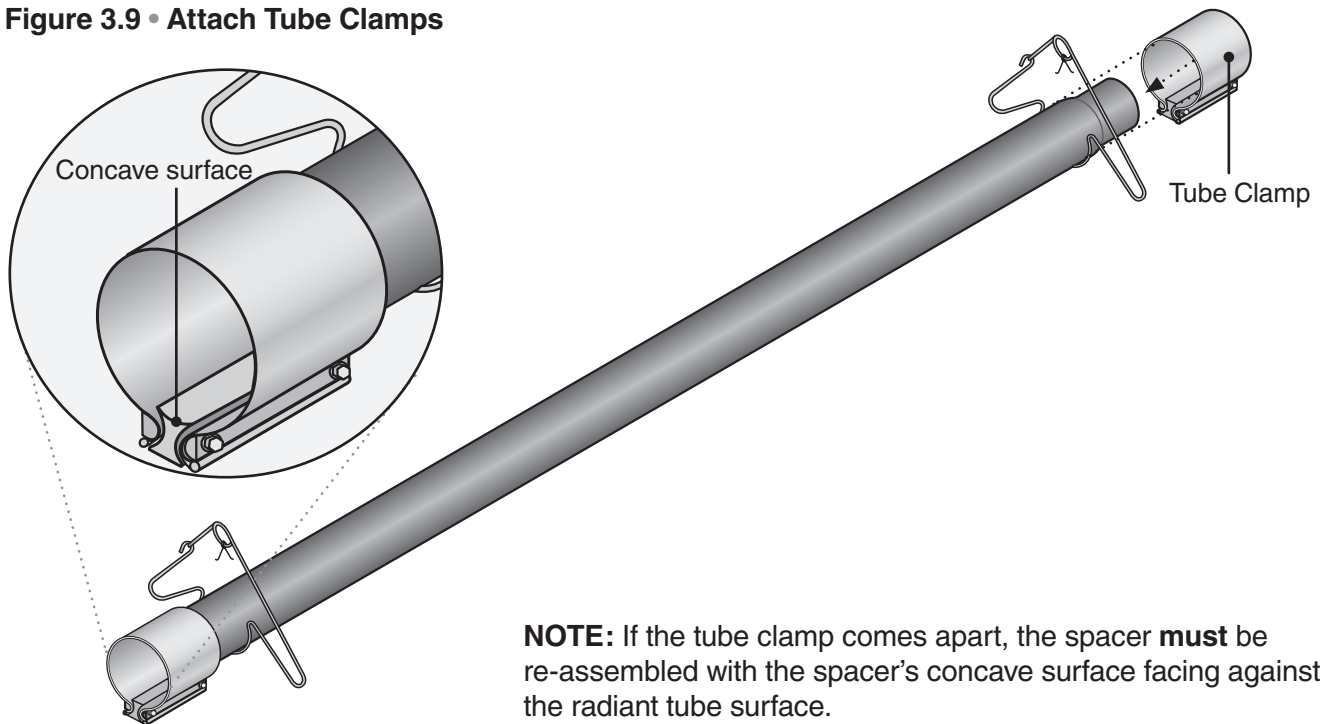

NOTE: If the tube clamp comes apart, the spacer **must** be re-assembled with the spacer's concave surface facing against the radiant tube surface.

- ③ Slip-fit the radiant tube sections together until tightly connected (install the swaged end of each tube towards exhaust end). **NOTE:** If it is difficult to mate the tubes, they may be installed incorrectly.
- ④ Center tube clamps over the seam where two radiant tube sections connect. If necessary, rotate tube clamps so they will not interfere with the reflector end caps during expansion and contraction of the heater.
- ⑤ Tighten tube clamp bolts to secure. When proper compression is obtained (40-60 ft-lbs. torque) the tube seam will create a visible mark on the tube clamp. **NOTE:** Excessive torque may damage the tube clamp.
- ⑥ Determine the location of the burner control box and note the placement of the mounting chains.

Figure 3.10 • Tube Connections

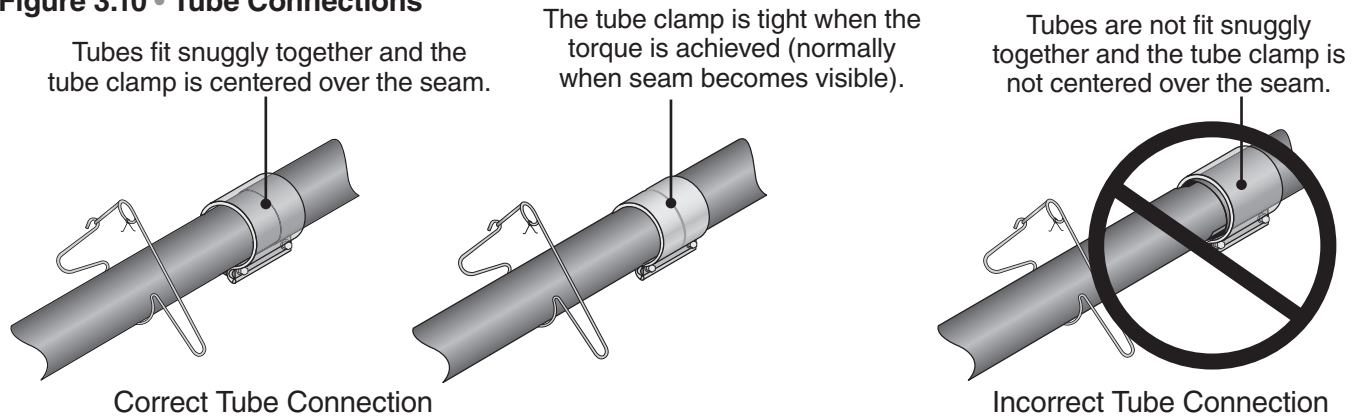

Optional Elbow or U-Bend Accessory Configuration

A 90 degree elbow or 180 degree U-bend accessory fitting may be installed in the radiant tube heating system. Refer to Chart 3.3 for minimum distance requirements from the burner control box.

When installing an Elbow or U-Bend Accessory Fitting:

- The top clearance of an uncovered (no reflector) elbow or U-bend accessory fitting to combustibles is 18 in.
- If operating the heater un-vented, separate the intake air to the heater from its exhaust products a minimum of 4 ft., further separation may be necessary. Combustion air may also be supplied.
- A maximum of two 90° elbows or one 180° U-bend can be installed on a heater.

Figure 3.11 • Optional Tube Connections

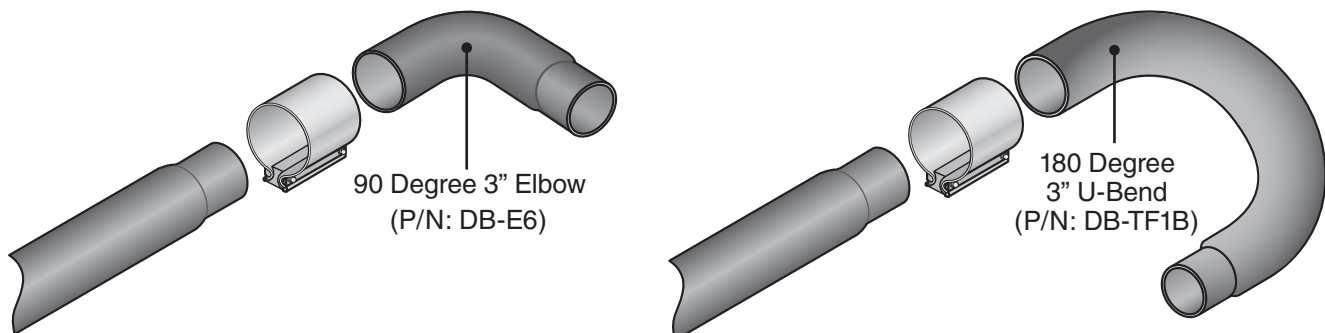

Figure 3.12 • Elbow and U-Bend Clearances

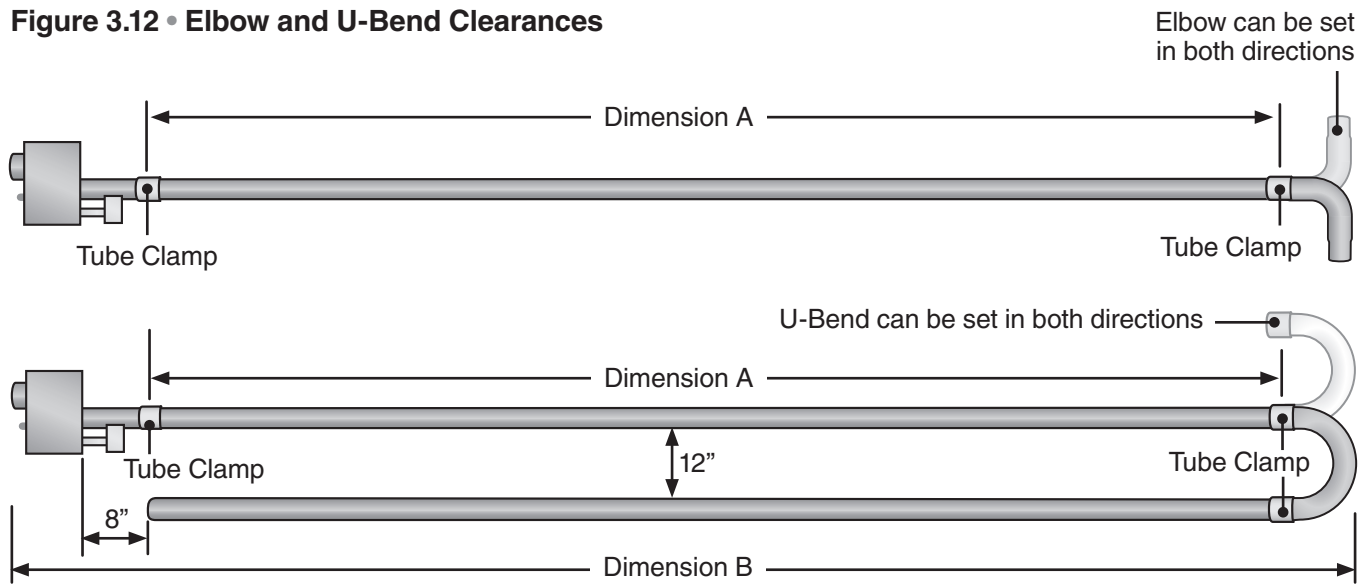

Figure 3.13 • U-Bend and Elbow Dimensions

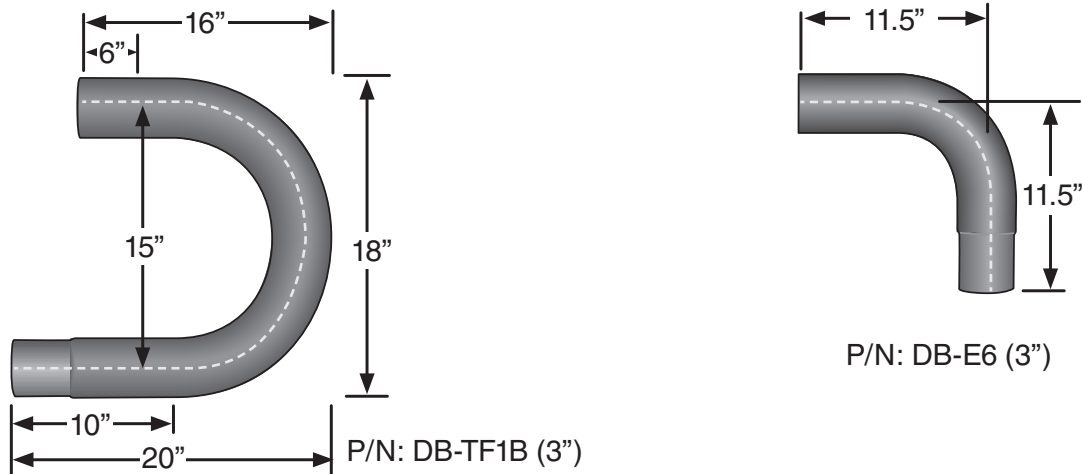

Chart 3.3
Minimum Distance From Burner Control Box to Elbow or U-bend Accessory Fitting

Model BTU Range	Dimension A
25,000	N/A
30,000	N/A
40,000	10 ft.
50,000	10 ft.

Chart 3.4
Overall Dimensions for Heaters Configured With U-Bend (P/N: DB-TF1B)

Tube Length	Dimension B	Notes
10 ft.	N/A	N/A
15 ft.	N/A	N/A
20 ft.	13'-0" / 156"	N/A
30 ft.	17'-8" / 212"	Requires P/N: DB-5EA-SUB *

* The DB-5EA-SUB add-on may only be ordered at the time of heater production. Field corrections require two (2) DB-TR-60 packages.

Burner Control Box Suspension

Suspending the burner control box must be done in accordance with applicable codes listed in the Safety section and these instructions.

The burner control box must be in straight alignment with radiant tubes and level. Contact your local distributor or the factory to see if your application allows for the rotation of the burner control box.

- ❶ Determine the mounting chain locations for hanging the burner control box.
- ❷ Fasten beam clamp, screw hook or other type of suspension anchor to hanging point.
- ❸ Attach S-hook and #1 double loop chain (P/N: THCS) to anchor. Check that it is securely connected.
- ❹ Attach chain assemblies and S-hooks to mounting brackets on the burner control box. Adjust chain lengths until level and in straight alignment with radiant tubes. Burner sight glass will be visible from the floor.

Figure 3.14 • Burner Control Box Assembly • Side View

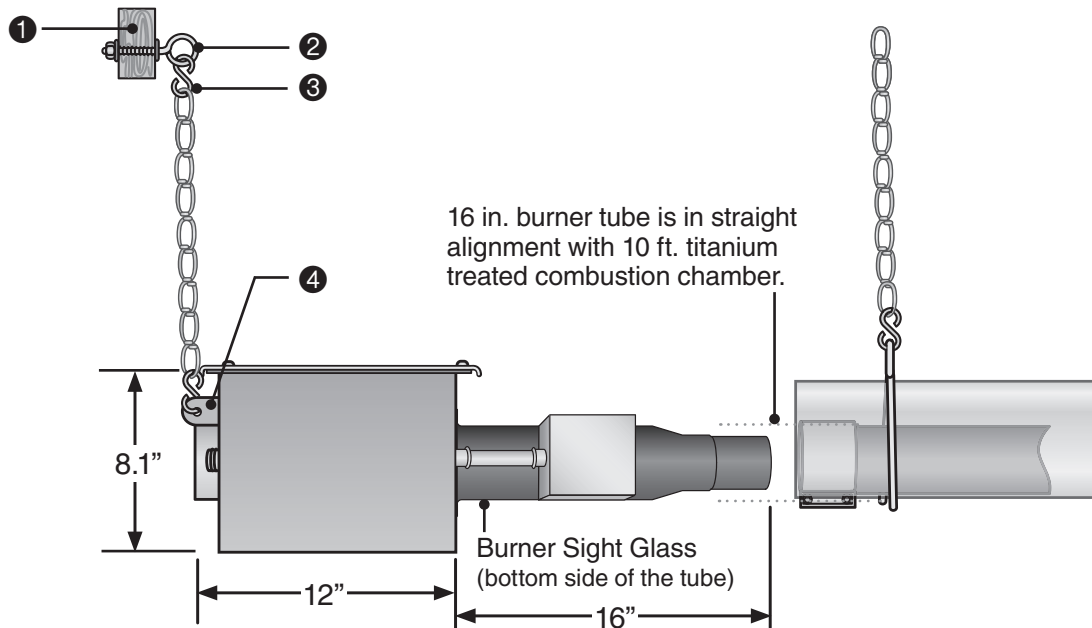
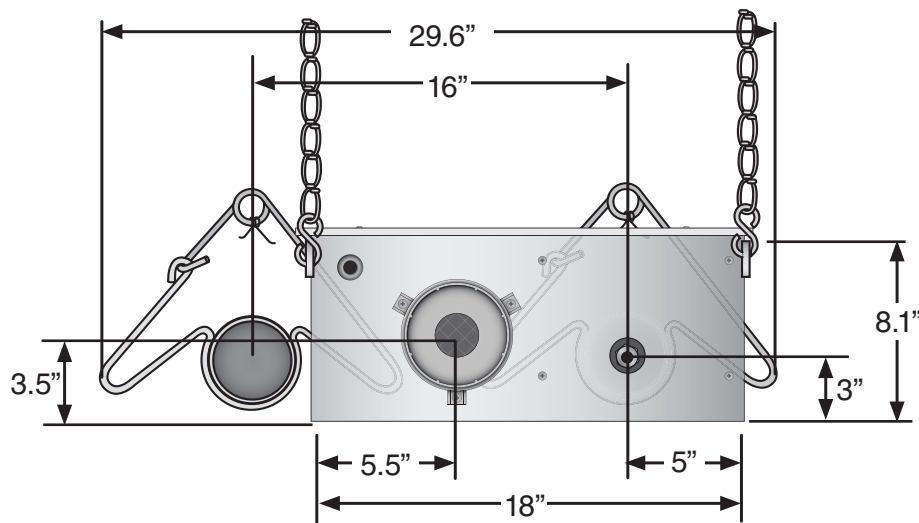

Figure 3.15 • Burner Control Box showing U-Shaped Configuration • End View



Reflector Assembly

To install the reflectors (see Figure 3.16):

- ① Attach the reflector center supports onto radiant tubes.
- ② Slide each reflector section through the hangers and adjust the reflector tension spring (if applicable) into the V-groove on the top of the reflector. The reflectors should overlap approximately 4 inches.
- ③ To prevent the reflectors from shifting, secure the reflector sections together using sheet metal screws, except at the expansion joint (see p.23). **NOTE:** Installer to supply sheet metal screws.
- ④ Attach reflector end caps with polished finish inward to each end of the reflector run. Secure with clips.

Reflectors and reflector accessories direct infrared energy to the floor level. The reflector assembly depends on the heater configuration, proximity to combustibles, and space surrounding the heater.

Before you begin assembly, determine if the use of reflector accessories are necessary (see Chart 3.5).

Figure 3.16 • Reflector Assembly

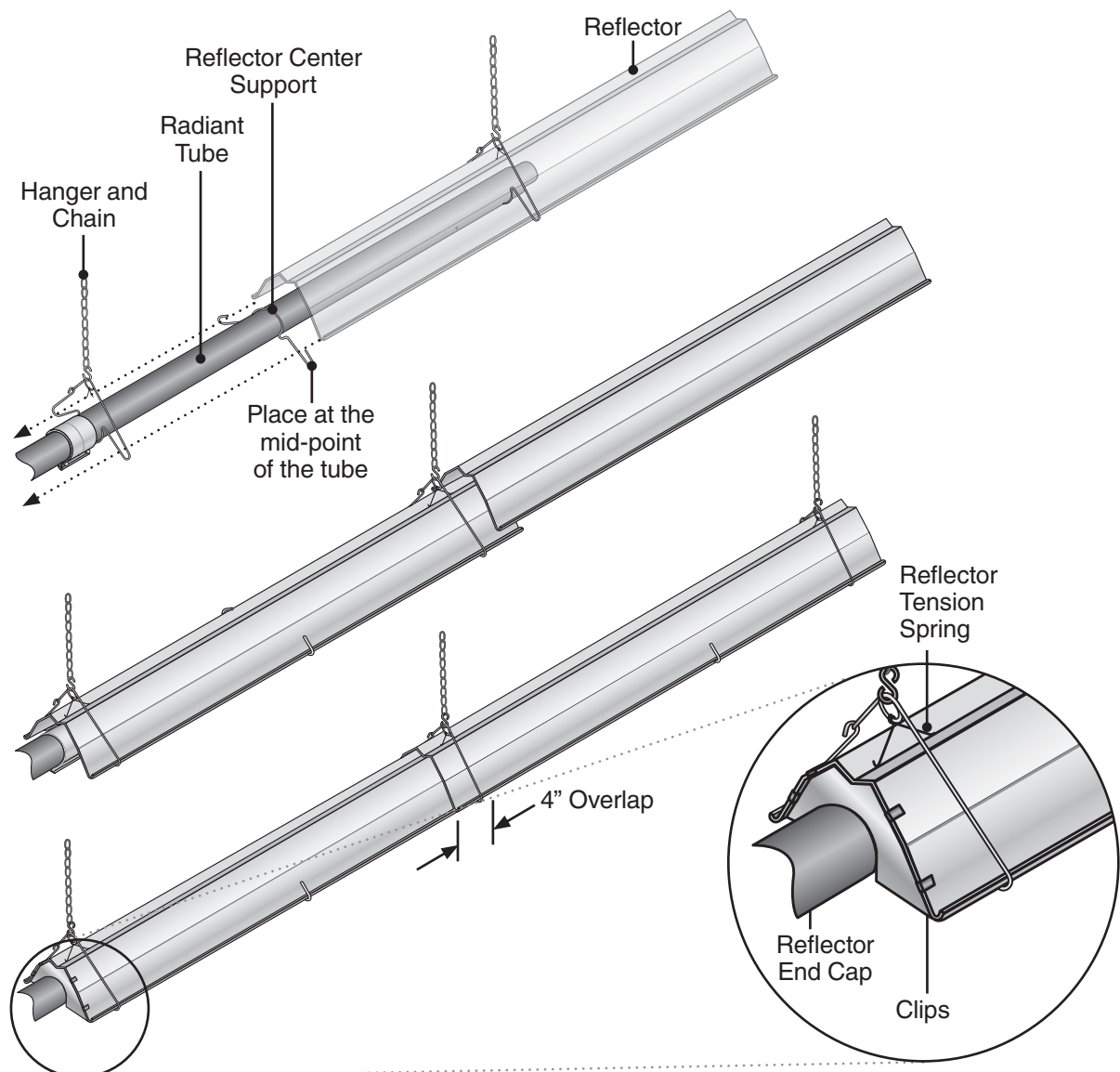

Chart 3.5
Common Optional Accessories

Reflector Accessory	Description	Part Number
Elbow Reflector*	90° bend, highly polished aluminum reflector elbow designed to fit atop one elbow accessory fitting.	RE
U-Reflector*	180° bend, highly polished aluminum reflector U-bend designed to fit atop one U-bend accessory fitting.	RU
Side Shield Extension**	Highly polished side shield extension used to direct infrared rays downward, away from sidewalls and combustibles.	SSE
Protective Guard	Used to prevent debris or objects from becoming lodged between the radiant tube and reflector. Required when mounting heaters below 8 ft.	PG

* Reflectors cannot be rotated when used with a reflector elbow (RE), U-shaped reflector (RU), or side shield (SSE).

** Refer to the Clearance to Combustible chart on page 9 for minimum distances to combustibles when side shield extension(s) are used.

Additional accessory options are listed in the Detroit Radiant Products Company Tube Heater Accessory Guide or online at www.detroitradiant.com.

Figure 3.17 • Reflector Shield Accessories

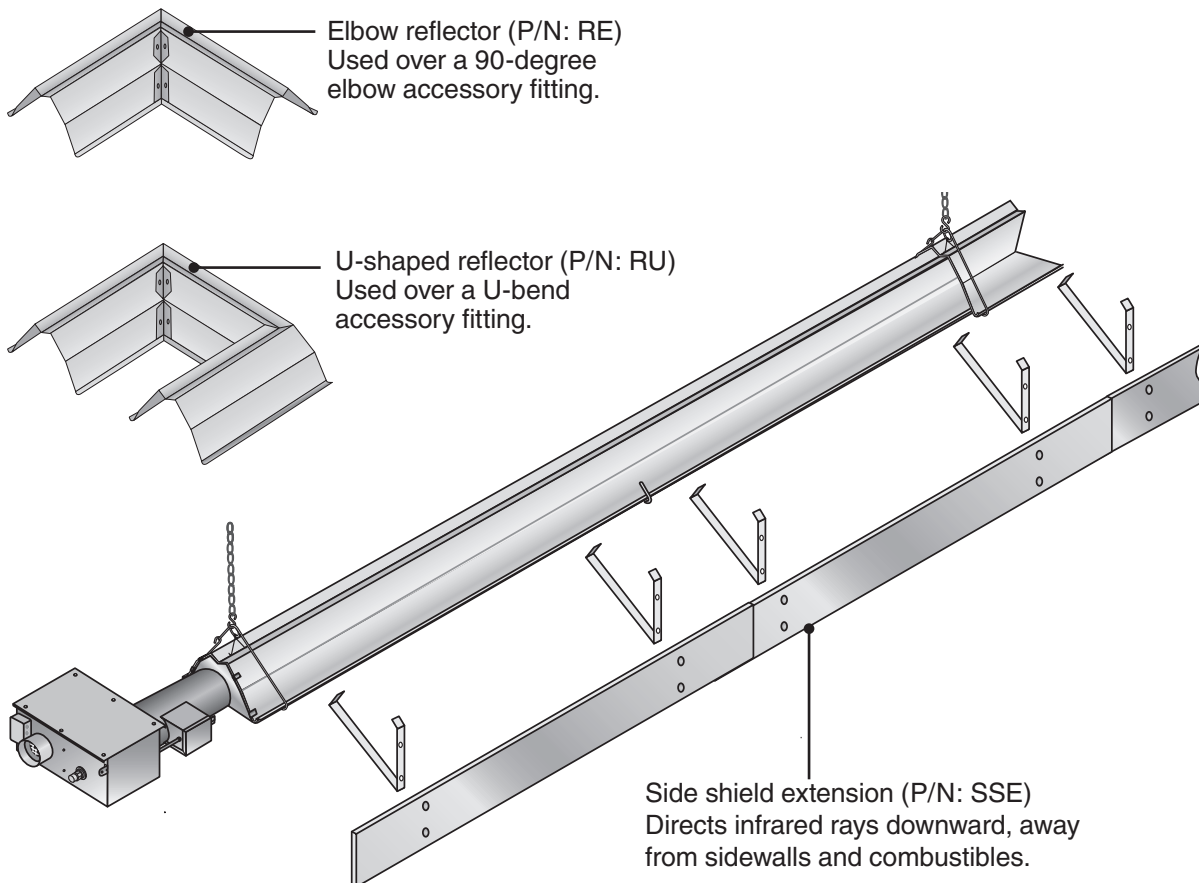

Baffle Assembly and Placement

To assemble the baffles: NOTE: Baffles may be inserted into the tube while being assembled.

- ❶ Identify one heat baffle (no fins) and two pressure baffles (with fins).
- ❷ Orient the baffle tabs at a 90° angle to the baffle keyhole (see Figure 3.18).
- ❸ Insert one baffle tab into keyhole and slide completely to one side until both baffle tabs appear in the keyhole.
- ❹ Adjust the tabs to the center of the keyhole and rotate the baffle 90 degrees to lock the baffle sections together.
- ❺ Repeat this process until all three baffle sections are connected.

Figure 3.18 • Assembling the Baffles

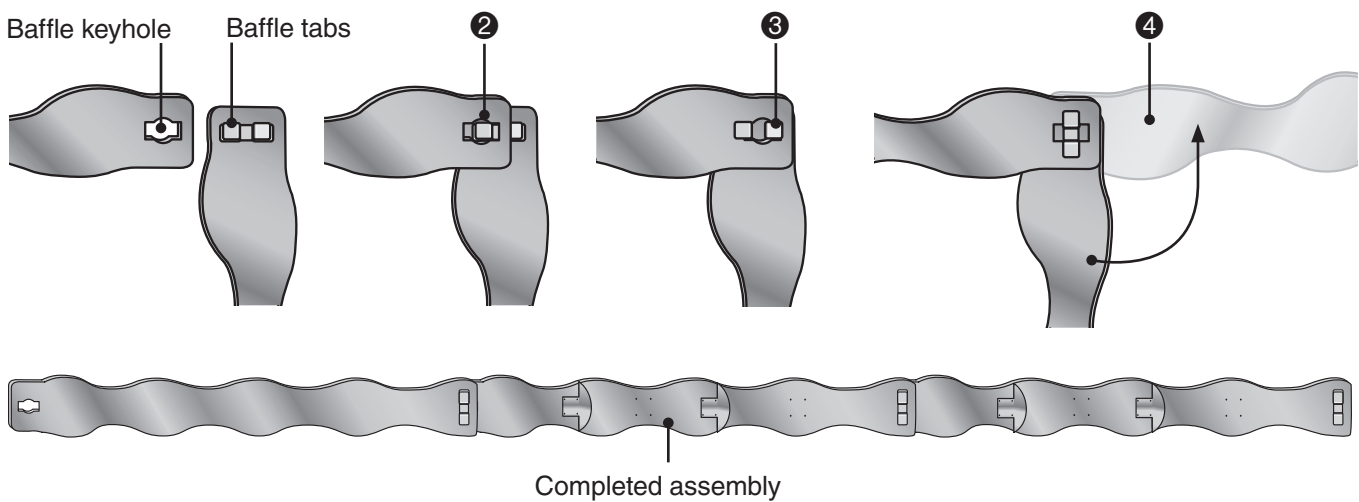

To insert the baffles:

- ❶ Insert baffles with the keyhole end first. **IMPORTANT:** Note insertion order and proper fin direction (80° towards exhaust end and 100° towards burner end (Figure 3.19)).
- ❷ Rotate baffle assembly so that it is in the **vertical position**.
- ❸ Slide baffle assembly into the last radiant tube section, furthest from burner control box.
NOTE: It may be necessary to cut the heat baffle into two sections when the heater is configured with a 'U' or 'L' shaped accessory fitting. In this case, place as much baffle as possible downstream of the 'U' or 'L' fitting and the remainder just before the fitting.

Figure 3.19 • Inserting the Baffles

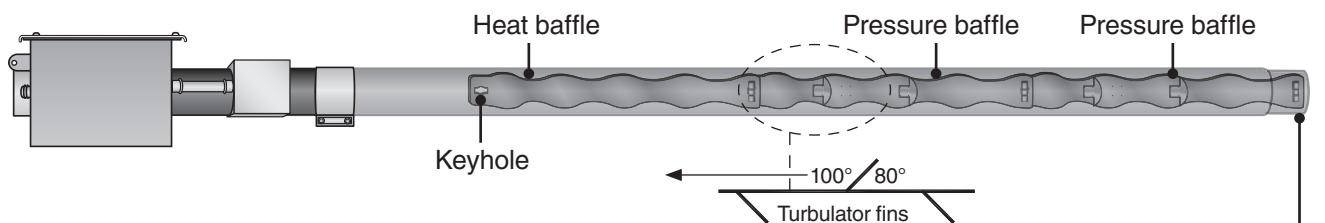





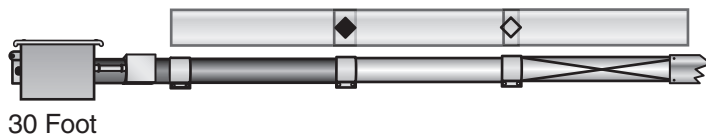
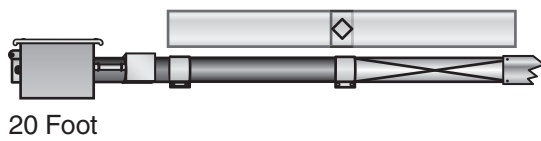
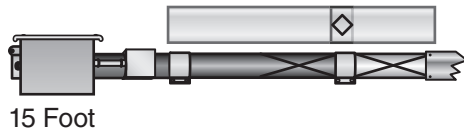
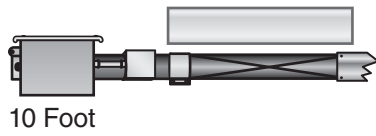

IMPORTANT: Baffle assembly must be flush with **the end** of the last tube section (exhaust end) and in the vertical position.

Final Heater Assembly

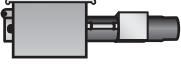
Chart 3.6

Tube Installation Sequence, Baffle Location and Secured Joints for Reflectors



Key			
	Burner Control Box w/16 in. Burner Tube		Aluminized Radiant Tube Exchanger with Clamp
	Expansion Joint on Reflectors		Baffle Location
	Secured Joint on Reflectors		Secure vent material to exchanger with three #8 sheet metal screws. Seal with high temperature silicone sealant. Do not use tube clamp.
	Titanium Treated Combustion Chamber with Clamp		

Venting

⚠ WARNING



Insufficient ventilation and/or improperly sealed vents may release gas into the building which could result in health problems, carbon monoxide poisoning or death.

Improper venting may result in fire, explosion, injury or death.



Seal vent pipes with high temperature sealant and three (3) #8 sheet metal screws. Vent enclosed spaces and buildings according to the guidelines in this manual and applicable national, state, provincial and local codes.

This tube heater must be vented in accordance with the requirements within this manual and all applicable codes for all models, prior to installing vent material. Local codes may vary.

In the absence of local codes:

United States: Refer to NFPA 54/ANSI Z223.1 (latest edition), National Fuel Gas Code.

Canada: Refer to CAN/CGA B149.1 and B149.2 Installation Codes for Gas Burning Appliances.

The heating system may operate either vented or un-vented (page 28). Venting can terminate through the sidewall (horizontal) or the roof (vertical) and be individually or commonly vented.

Venting Requirements

- This appliance **must** be vented in residential installations.
- 3 in. single wall 26 gauge (min.) galvanized steel vent pipe or Dura/Connect single wall flexible exhaust vent must be used.
- Maximum vent length for all models is 20 ft. (6 m).
- Single wall galvanized vent pipe must be insulated in cold environments.
- Seal single wall vent with high temperature sealant and three (3) #8 sheet metal screws.
- Do not use more than two 90° elbows in the exhaust vent.
- To maintain clearances to combustibles, the use of an approved wall or roof thimble and double-wall Type B-vent is required for the portion of vent pipe that runs through combustible material in the building wall or roof (see Figures 3.20 & 3.21).
- Consult the NFPA ANSI Z223.1 Gas Vent Termination criteria if roof pitch exceeds 9:12.

Figure 3.20 • General Vent Requirements

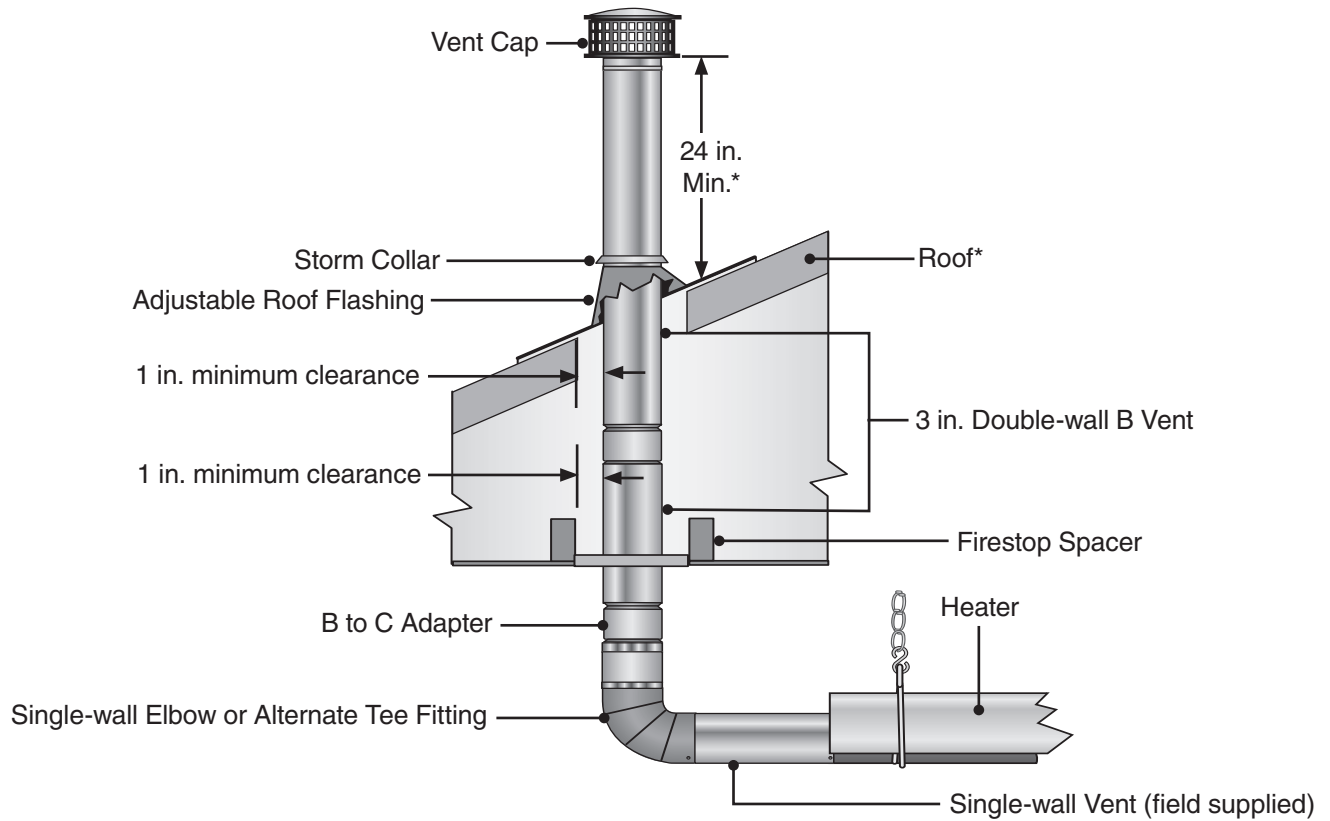

*Consult the NFPA ANSI Z223.1 Gas Vent Termination criteria if roof pitch exceeds 9:12

Sidewall Venting

Guidelines:

Vent Pipe Angle

- To prevent moisture from entering the heater system, slope the vent pipe down toward the outlet 1/4 in. per foot of length. **Do not** pitch the heater.
- Vent must be a minimum of 36 in. below or extend beyond any combustible overhang.

Figure 3.21 • Sidewall Venting Requirements

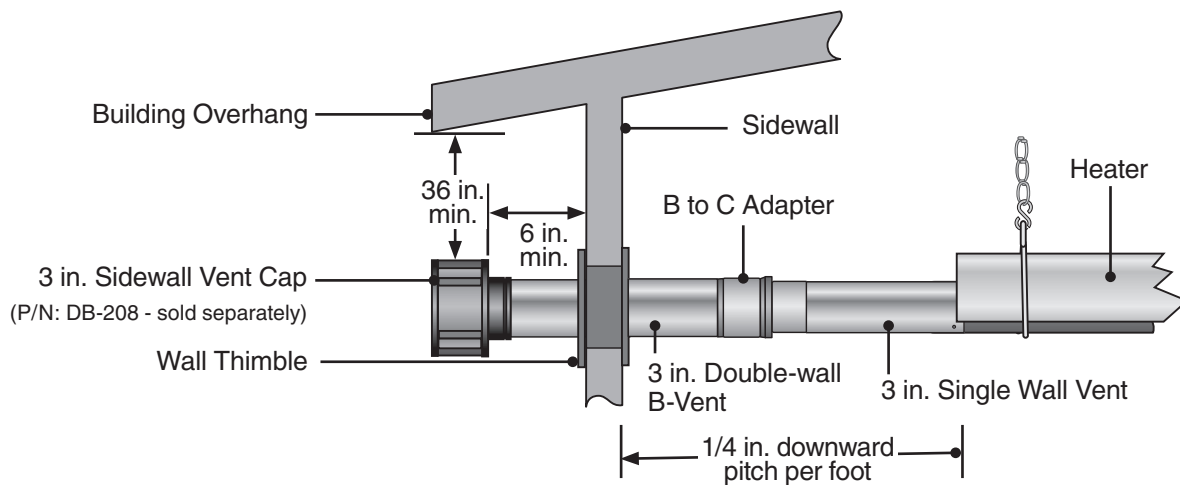

Vent Termination

United States:

- Vent must terminate a minimum of 4 ft. below, 4 ft. horizontally from, and 1 ft. above any window or door that may be opened or gravity air inlet into the building.
- Vent must terminate a minimum of 3 ft. above any forced air inlet that is located within 10 ft.
- The bottom of the vent terminal must be located a minimum of 12 in. above grade level and must extend beyond any combustible overhang. Vents adjacent to public walkways must terminate a minimum of 7 ft. above grade level.
- The vent terminal must be installed to prevent blockage by snow and protect building materials from degradation by flue gases.
- The vent cap must be a minimum of 6 in. from the sidewall of the building.
- Vent must be a minimum of 36 in. below or extend beyond any combustible overhang.
- Consult the NFPA ANSI Z223.1 Gas Vent Termination criteria if roof pitch exceeds 9:12.

Canada:

- Vents must terminate a minimum of 3 ft. from a window or door that may be opened, and non-mechanical air supply inlet or combustion air inlet into the building.
- Vents must terminate a minimum of 6 ft. from a mechanical air supply inlet.

Rooftop Venting

Guidelines:

Vent Locations and Clearances

- Separate air intake duct from vent pipe a minimum of 4 ft. by placing vent pipes higher than adjacent air intake duct.
- Venting may utilize standard B-vent cap.
- The vent terminal must extend a minimum of 2 ft. above the roof.

Figure 3.22 • Rooftop Venting - Side View

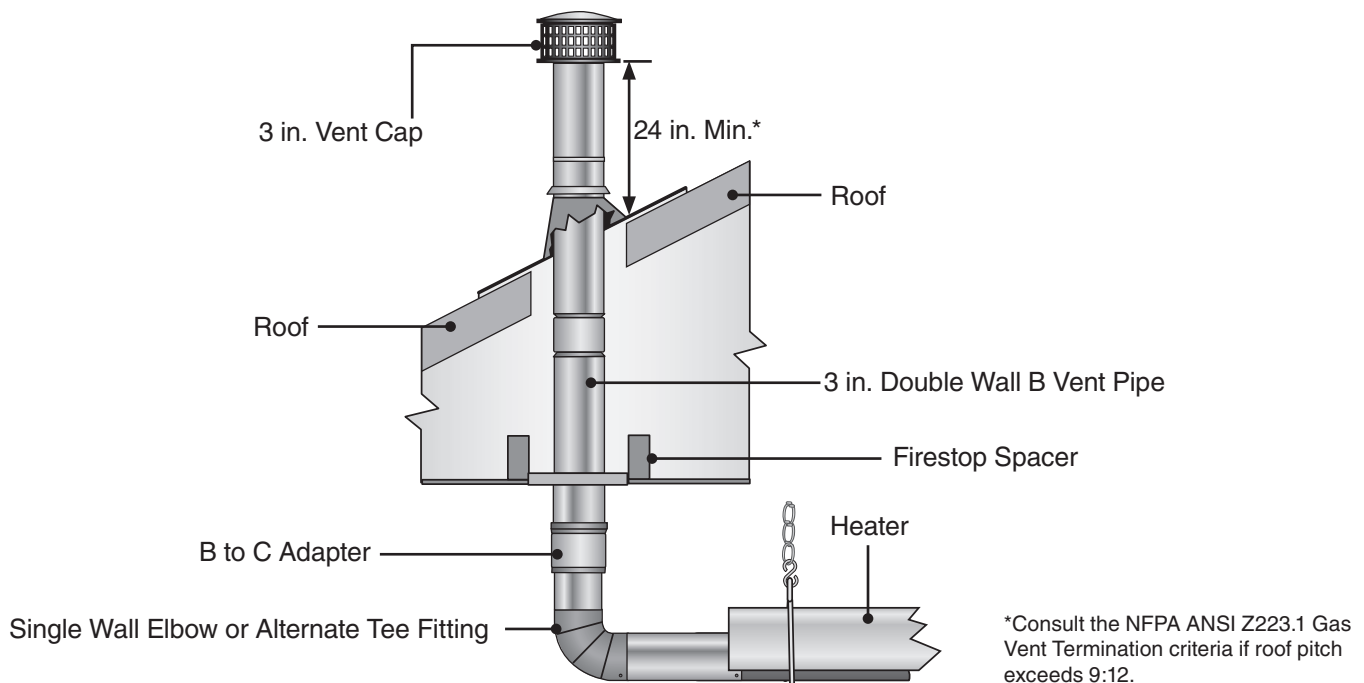

Common Venting

- A staggered arrangement or a dual exhaust assembly (P/N: DB-Y) must be used when joining two heaters to a common vent so that by-products of one heater do not flow into the adjoining vent of the other heater.
- 4 in. diameter double-wall Type B-vent and 4 in. vent cap must be used.
- Common vented heaters **must be** controlled with the same thermostat. **Do not operate individually.**

Figure 3.23 • Common Rooftop Venting - Side View

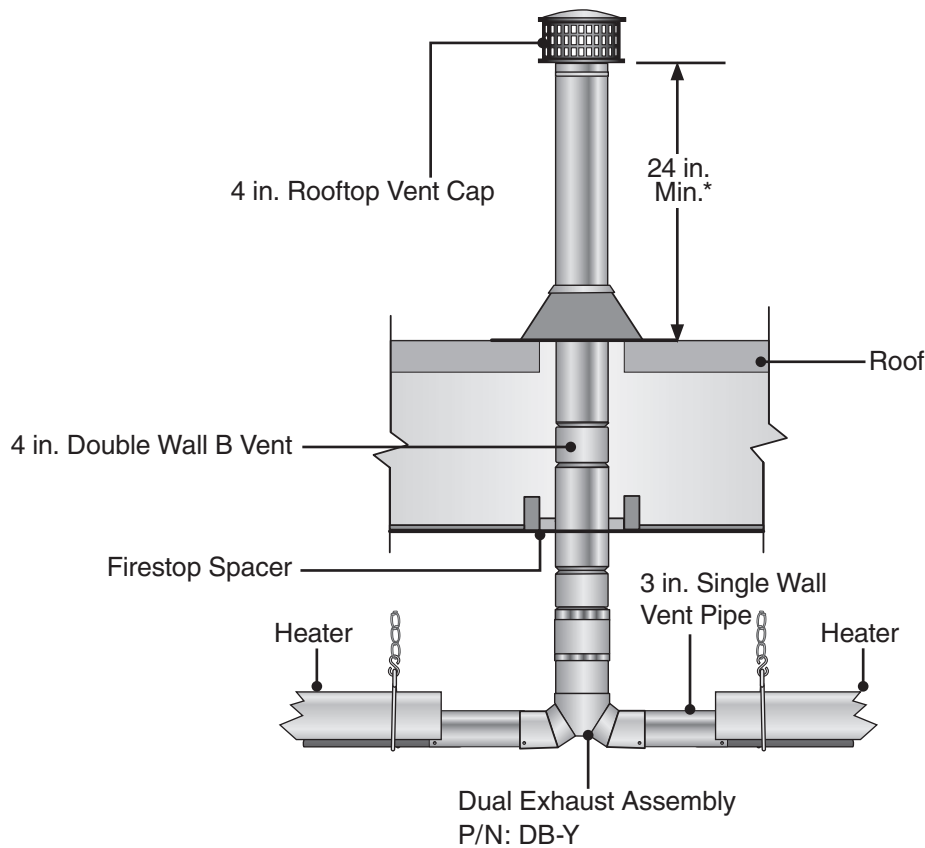

*Consult the NFPA ANSI Z223.1 Gas Vent Termination criteria if roof pitch exceeds 9:12.

Figure 3.24 • Common Sidewall Venting - Top View

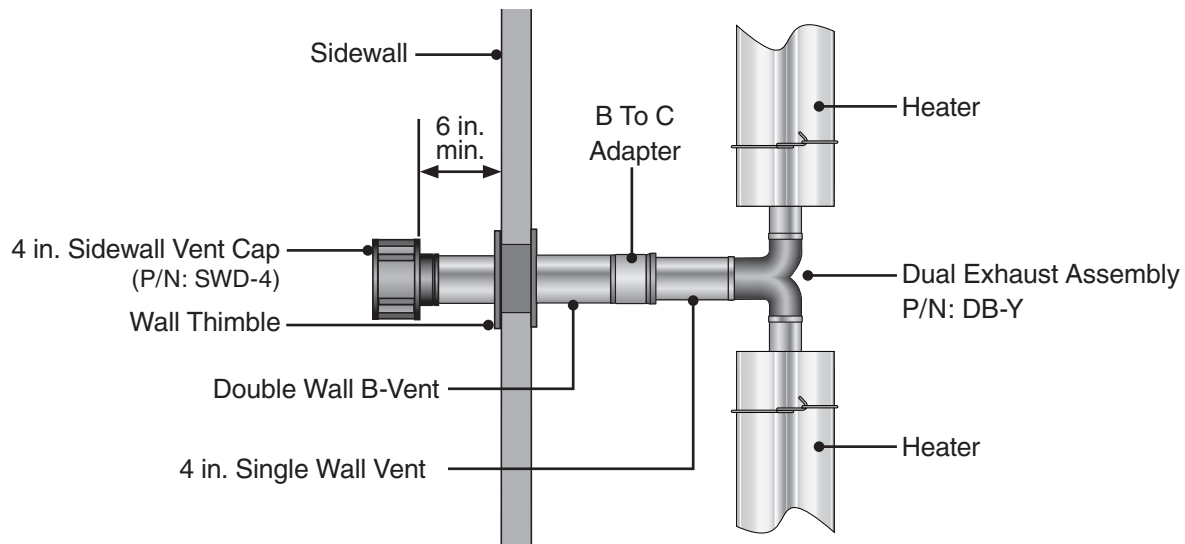

Optional Unvented Operation

⚠ WARNING



This appliance must be vented in residential installations. Unvented tube heaters in residential spaces may result in property damage, serious injury or death. Use unvented operation in commercial and industrial installations with proper ventilation rates only.

When using an unvented configuration (commercial & industrial use only), **consider the following:**

- A factory vent cap/diffuser (P/N: WVE-3) **must** be used.
- Where unvented heaters are used, natural or mechanical means **must** be provided to supply and exhaust a minimum of 4 cfm/1000 Btu/h input of installed heaters.

NOTE: Gravity or mechanical means may be used to accomplish the air displacement. Local codes may require that the mechanical exhaust system be interlocked with the electrical supply line to the heaters, enabling both to function simultaneously.

- The minimum clearance between the air intake and the exhaust terminal is 4 ft.
NOTE: When installing in a U-tube configuration, use extra caution to separate vent gases from heater intake.
- Exhaust openings for removing the flue products must be located above the level of the heater(s).
- Use of combustion air intake.

Figure 3.25 • Minimum End Clearances

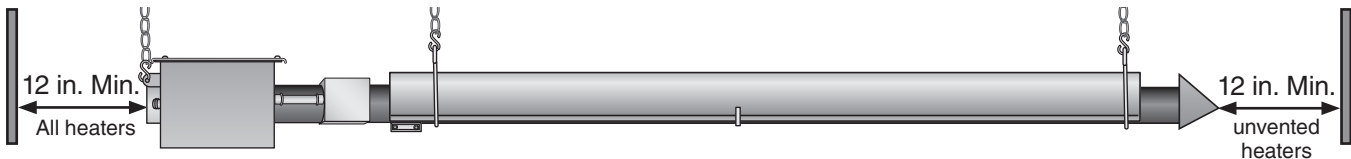

Combustion Air Requirements

Combustion air may be supplied to the heater by indoor or outdoor means.

If using combustion air from indoors, the required volume of the space must be a minimum of 50 ft³ per 1000 Btu/hr unless the building is of unusually tight construction. If the building is of unusually tight construction with air infiltration rates of less than 0.40 air changes per hour, outside combustion air is typically needed unless the sheer size of the building allows otherwise. Contact the factory for further determination of air infiltration rates.

Non-contaminated outside air for combustion must be ducted to the heater if any of the following apply:

- Chemicals such as chlorinated or fluorinated hydrocarbons (typical sources are refrigerants, solvents, adhesives, degreasers, paints, paint removers, lubricants, pesticides, etc.).
- High humidity.
- Contaminants such as sawdust, welding smoke, etc.
- Negative building pressure.
- Unusually tight construction where there is an air infiltration rate of less than 0.40 air changes per hour.

Combustion air intake may be located on either the sidewall or roof (see Figures 3.26 - 3.28).

Figure 3.26
Vertical Outside Air Supply for
Single Heater Intake • Side View

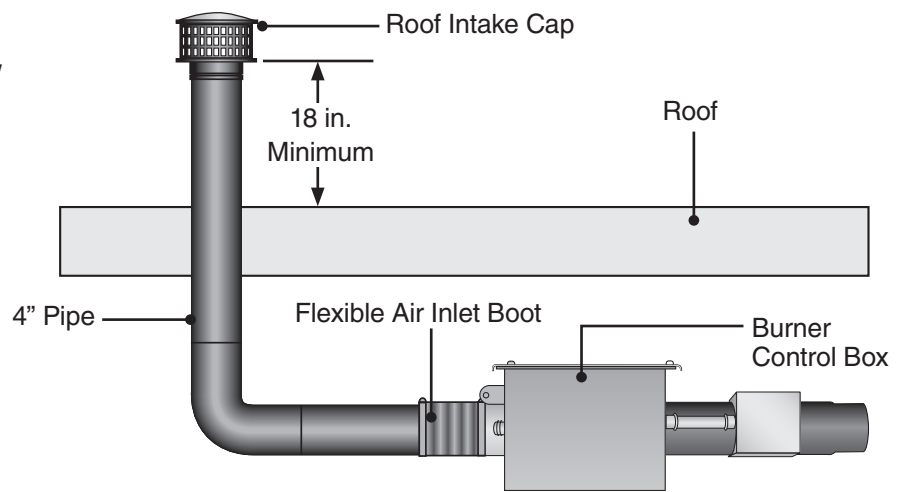

Figure 3.27
Horizontal Outside Air Supply
for Single Heater Intake • Side View

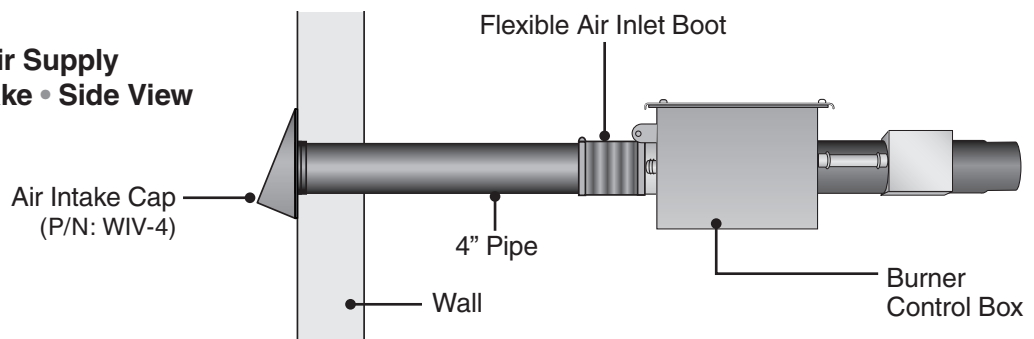
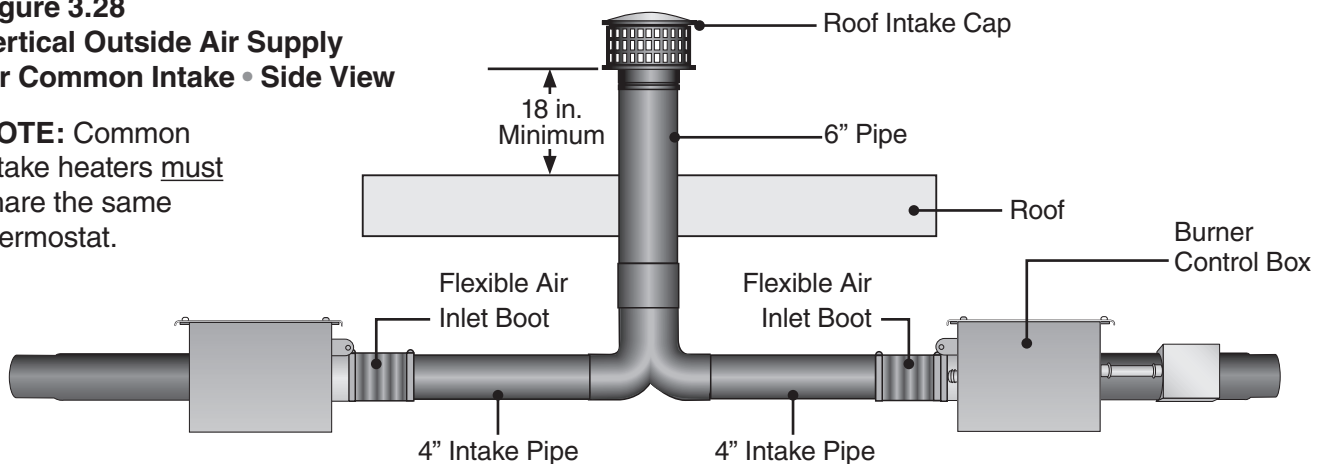

Figure 3.28
Vertical Outside Air Supply
for Common Intake • Side View

NOTE: Common intake heaters must share the same thermostat.



Guidelines:**Chart 3.7****Limitations for Length and Size of Combustion Air Intake Duct**

Single Heater Intake		Dual Heater Intake	
Air Intake Duct Size	Max. Intake Length	Duct Size	Max. Intake Length
4 in.	20 ft.	4 in.(single)/6 in.(dual)	20 ft.
5 in.	30 ft.	4 in.(single)/8 in.(dual)	30 ft.
6 in.	40 ft.	Consult factory for longer intake lengths.	

General

- No more than two 90 degree elbows are allowed.
- Allow for expansion. Use a 4 in. flexible hose to connect the duct to the burner control box.
- In humid environments, use insulated duct, PVC pipe or DWV (drain waste vent) to prevent condensation on the outer surface.
- Do not draw air from attic space.
- A factory approved wall intake cap (P/N: WIV-4) must be used with horizontal outside intake ducts. The wall intake cap must be installed to prevent blockage. Locate the intake where dirt, steam, snow, etc. will not contaminate or clog the intake screen.
- Separate air intake duct from vent pipe a minimum of 4 ft. Also, place vent pipe higher than adjacent air intake duct.

Gas Supply**⚠ WARNING**

Improperly connected gas lines may result in fire, explosion, poisonous fumes, toxic gases, asphyxiation or death. Connect gas lines in accordance to national, state, provincial and local codes.

Important! Before connecting the gas supply to the burner control box:

- Verify that the heater's gas type (as listed on the rating plate) matches that of your application and the installation complies with national and local codes and requirements of the local gas company.

Unless otherwise noted on the rating plate, this infrared heater is designed and orificed to operate on standard BTU gas. Contact the factory if utilizing non-standard BTU gas.

HIGH ALTITUDE: Installation of this tube heater is approved, without modifications, for elevations up to 6,000 feet (1,829 m) MSL (sea level) in the United States. Contact the factory for installations above these elevations.

- Check that the gas piping and service has the capacity to handle the total gas consumption of all heaters being installed, as well as any other gas appliances being connected to the supply line.
- Check that the main gas supply line is of proper diameter to supply the required fuel pressures.
- If utilizing used pipe, verify that its condition is clean and comparable to a new pipe. Test all gas supply lines in accordance with local codes.

- Test and confirm that inlet pressures are correct. Refer to the heater rating plate for gas type and the required minimum and maximum pressures (see Chart 3.8). The gas supply pipe must be of sufficient size to provide the required capacity and inlet pressure to the heater (if necessary, consult the local gas company). Do not exceed the maximum allowed pressures for the heater, the space or the gas piping system.

Chart 3.8 Manifold Pressure

Type of Gas	Required Manifold Pressure	Minimum Inlet Pressure	Maximum Inlet Pressure
Natural	3.5 Inches W.C.	5.0 Inches W.C.	14.0 Inches W.C.
Liquefied Petroleum	10.0 Inches W.C.	11.0 Inches W.C.	14.0 Inches W.C.

NOTE: Check manifold pressure at the tap on the gas valve. Small variations in manifold pressure (actual vs. published) may exist due to changing atmospheric conditions. Readings will be above atmospheric pressure.

Pressure Equivalents: 1 Inch W.C. equals .058 oz/sq. in. equals 2.49 mbar.

To connect the gas:

⚠ WARNING



Failure to install, operate or service this appliance in the approved manner may result in property damage, injury or death. Only trained, qualified gas installation and service personnel may install or service this equipment.

The installation must conform with local building codes or, in the absence of such codes, the National Fuel Code (NFPA 54) and in conjunction with ANSI Z21.24/CSA 6.10 “Connectors for Gas Appliances”.

IMPORTANT! The heating system will expand and contract during operation. **Allowances for expansion must be made between the connection to the heater and the gas supply.** Excessive bending, kinks, twists or vibration must be avoided. A flexible gas connection of approved type is required. Flexible stainless steel gas connectors installed in one plane, and without sharp bends, kinks or twists is recommended.

The gas pipe and connection **must** be supported independently. Do not install gas supply line in a manner that bears the weight of the heater. Connect the main gas supply line with an approved flexible connector (Figure 3.29) or, if national or local codes require rigid piping, a swing joint. Heater shall not be connected to the building piping system with rigid pipe or semi-rigid metallic tubing, including copper. When using such material, an intermediate connection device that allows for heater expansion must be used.

The gas outlet must be in the same room as the appliance and accessible. It may not be concealed within or run through any wall, floor or partition. When installing the heater in a corrosive environment (or near corrosive substances), use a gas connector suitable for the environment. Do not use the gas piping system to electrically ground the heater.

- 1 Install a sediment trap / drip leg if condensation may occur at any point of the gas supply line. This will decrease the possibility of loose scale or dirt in the supply line entering the heater’s control system and causing a malfunction. **NOTE:** High pressure gas above 14 Inches W.C. (water column pressure) requires a high pressure regulator and ball valve.

- ② Form the stainless steel flexible connector into a smooth C-shape allowing 12 in. between the flexible connector's end nuts (see Figure 3.29).
- ③ Attach the ball valve to the gas supply pipe. Apply pipe compound to NPT adapter threads to seal the joint. Use only a pipe compound resistant to LP. **NOTE:** Provide a 1/8 in. NPT plugged tapping accessible for test gauge connection immediately upstream of gas connection to the heater (provided on ball valve).

⚠ CAUTION

When using a stainless steel flexible gas connector, **do not** attach the connector nuts directly to the gas pipe supply. Connector nuts must be installed to an approved adapter.

- ④ Attach the flexible connector to the adapter and burner control box inlet. Seal the joints. **NOTE:** Excessive torque on the manifold may misalign the orifice. **Always** use two wrenches to tighten mating pipe connections.
- ⑤ Final assembly must be tested for gas leaks according to NFPA 54 and all local codes and/or Standards.

⚠ WARNING



Testing for gas leaks with an open flame or other sources of ignition may lead to a fire or explosion and cause serious injury or death. Test in accordance with NFPA or local codes.

Figure 3.29 • Gas Connection (Flexible Gas Connection shown) • Side View

NOTE: Do not exceed 14 Inches W.C. to the appliance.

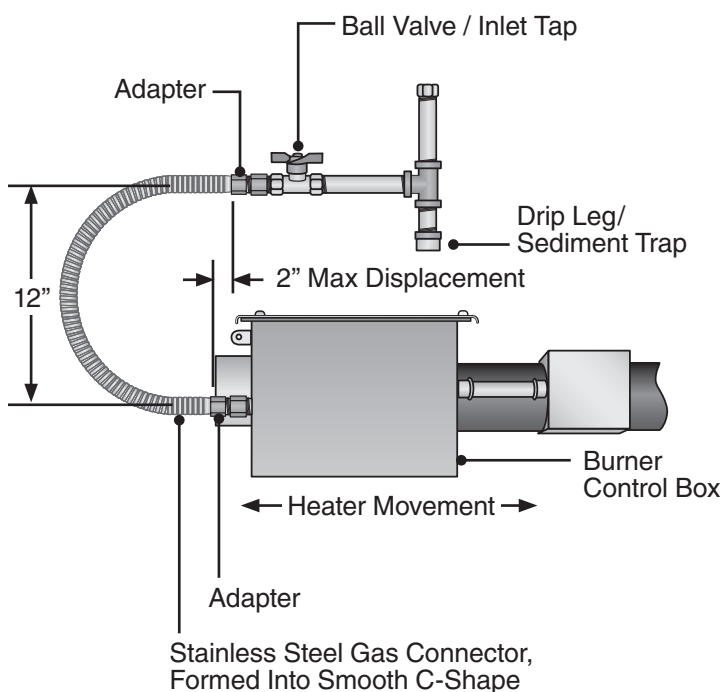
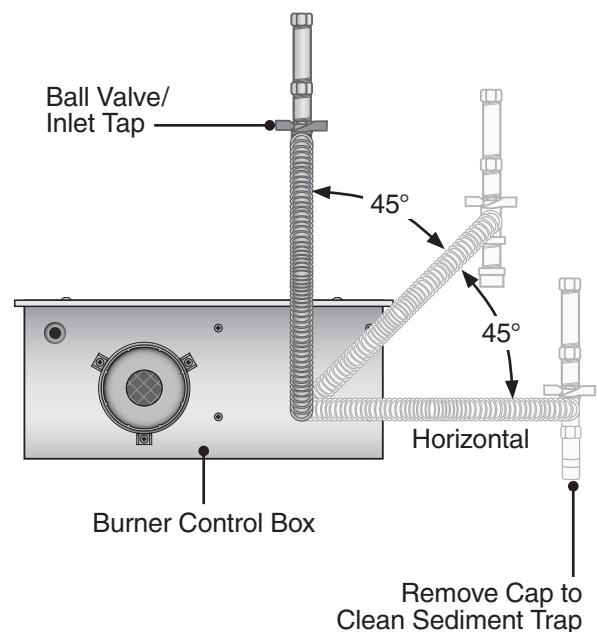

Figure 3.30 • Gas Connection (Flexible Gas Connection shown) • End View



Electrical Requirements

⚠ WARNING



Improper installation, adjustment, alteration, service or maintenance can cause property damage, serious injury or death. Read and understand, the installation, operating and maintenance instructions thoroughly before installing or servicing this equipment. Only trained, qualified gas installation and service personnel may install or service this equipment.

The tube heater must be electrically grounded in accordance with the following codes:

United States: Refer to National Electrical Code®, ANSI/NFPA 70 (latest edition). Wiring must conform to the latest edition of National Electrical Code®, local ordinances, and any special diagrams furnished.

Canada: Refer to Canadian Electrical Code CSA C22.1 Part 1 (latest edition).

Thermostat

NOTICE

Connecting the thermostat with a voltage other than 24V may damage the heater. The LD Series requires a 24V connection to the thermostat. This is either supplied by the heater internally (standard) or by an external transformer (with optional relay board, P/N: HLRB). See below.

- 120 Volt - 60 Hz GRD, 3-wire.
- 24V thermostat connection.
- Starting current 4.8 amps
- Running current 1.1 amps

The LD Series is equipped with or without a relay board (P/N: HLRB). The optional relay board must be factory installed.

Standard Configuration

Without relay board (identified with white crescent around the terminal block):

- Single burner control box.
- Single thermostat.

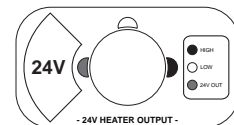

Optional Configuration

With relay board (identified with orange crescent around the terminal block):

- A single thermostat controls two or more burner control boxes.
- Heaters are common vented.
- Must be factory installed.

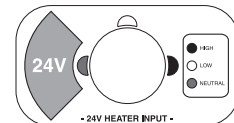

NOTE: Units with a relay board installed must have an external transformer (field supplied), see wiring diagram (Figure 3.1B).

LD Series heaters require a 24V, two stage thermostat to operate. The burner control box is equipped with either a round terminal strip that accepts three (3) 1/4" insulated female spade terminals or a 36" yellow 24V control wire. Do not supply 120V to the 24V connection. The 120V connection is factory wired with a three-prong pig tail. Refer to LD Series field wiring diagram (Figure 3.1).

NOTE: Different thermostats operate according to their particular features. Refer to thermostat specifications for details.

Wiring

⚠ WARNING



Electric Shock

Field wiring to the tube heater must be connected and grounded in accordance with national, state, provincial, local codes and to the guidelines in the Tube Heater General Manual and Series Insert Manual. In the United States refer to the most current revisions to the ANSI/NFPA 70 Standard and in Canada refer to the most current revisions to the CSA C22.1 Part I Standard.

Figure 3.1 • Field Wiring Diagrams

A. Single Heater, Single Thermostat. No Relay Board (white label)

NOTE: If optional yellow control cord is installed, the following colors apply:

24V - Green
Low - White
High - Black

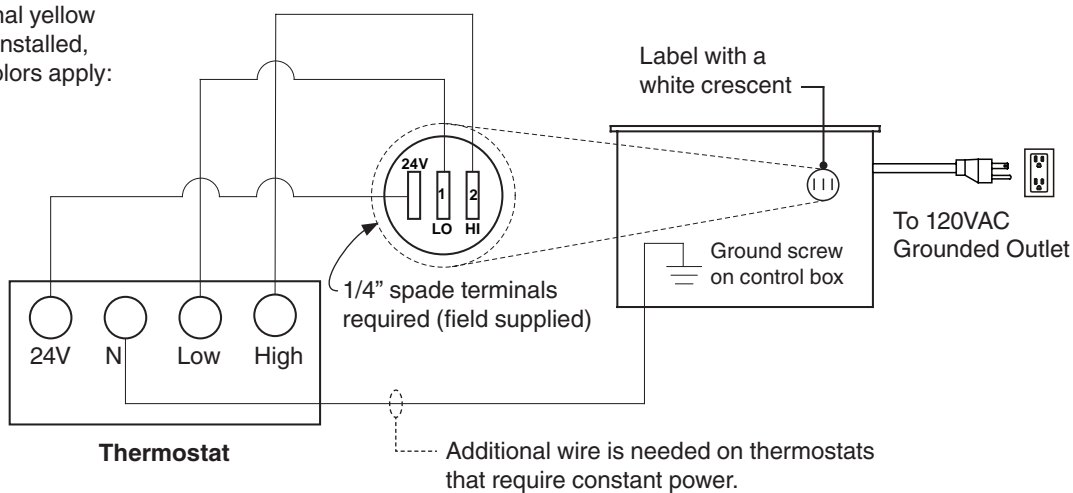

B. Multiple Heaters, Single Thermostat. With a Relay Board (HLRB orange label)

NOTE: If optional yellow control cord is installed, the following colors apply:

24V - Green
Low - White
High - Black

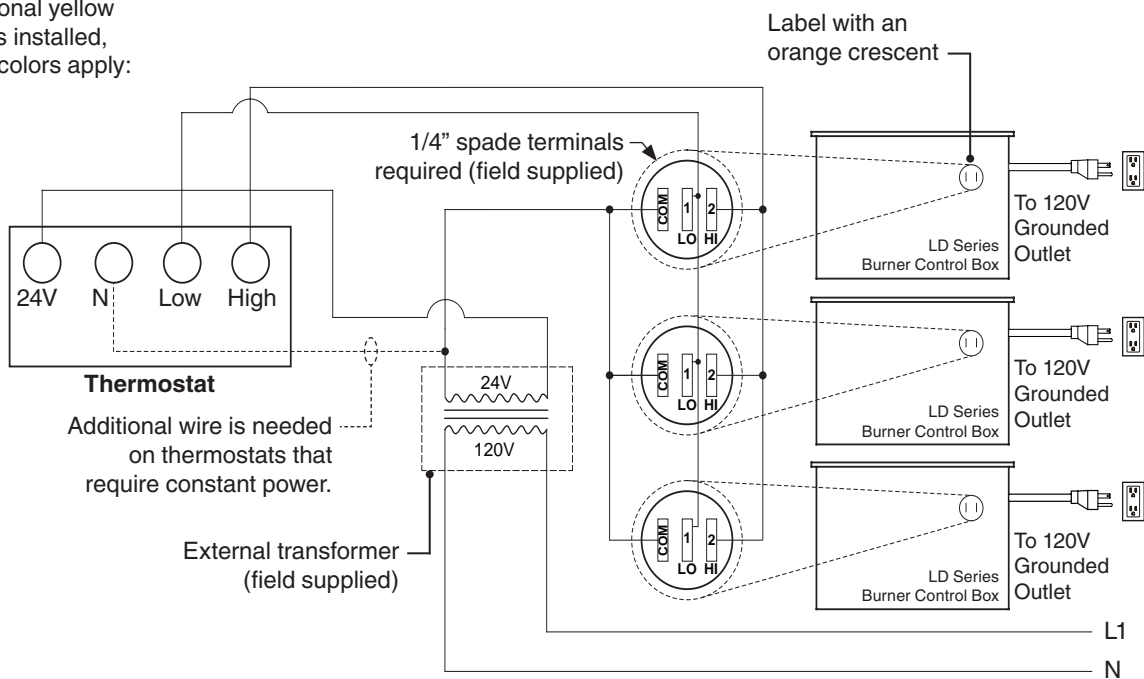

Before field wiring this appliance - Check existing wiring; replace if necessary.

NOTE: If any of the original wire supplied with the appliance must be replaced, it must be replaced with wiring material having a temperature rating of at least 105° C.

Figure 3.2 • LD Series Internal Wiring Diagrams

A. LD Micro 60U-24 Ladder Diagram

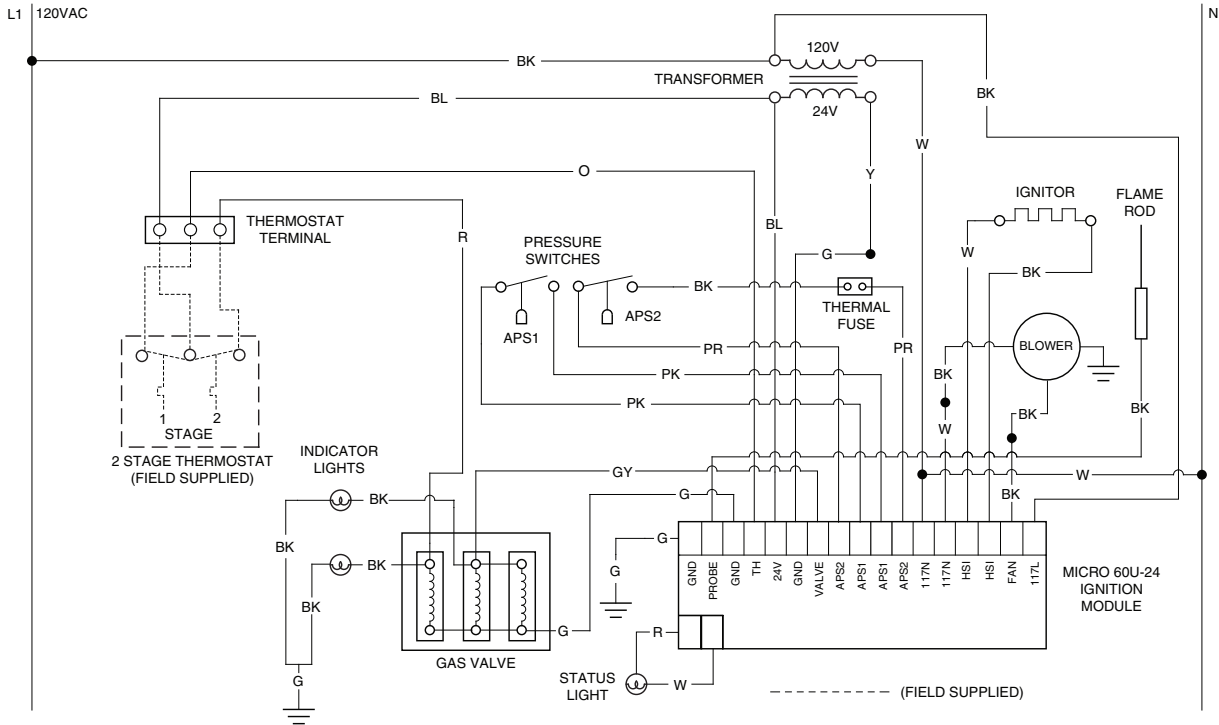

B. LD Series Micro 60U-24 Block Diagram

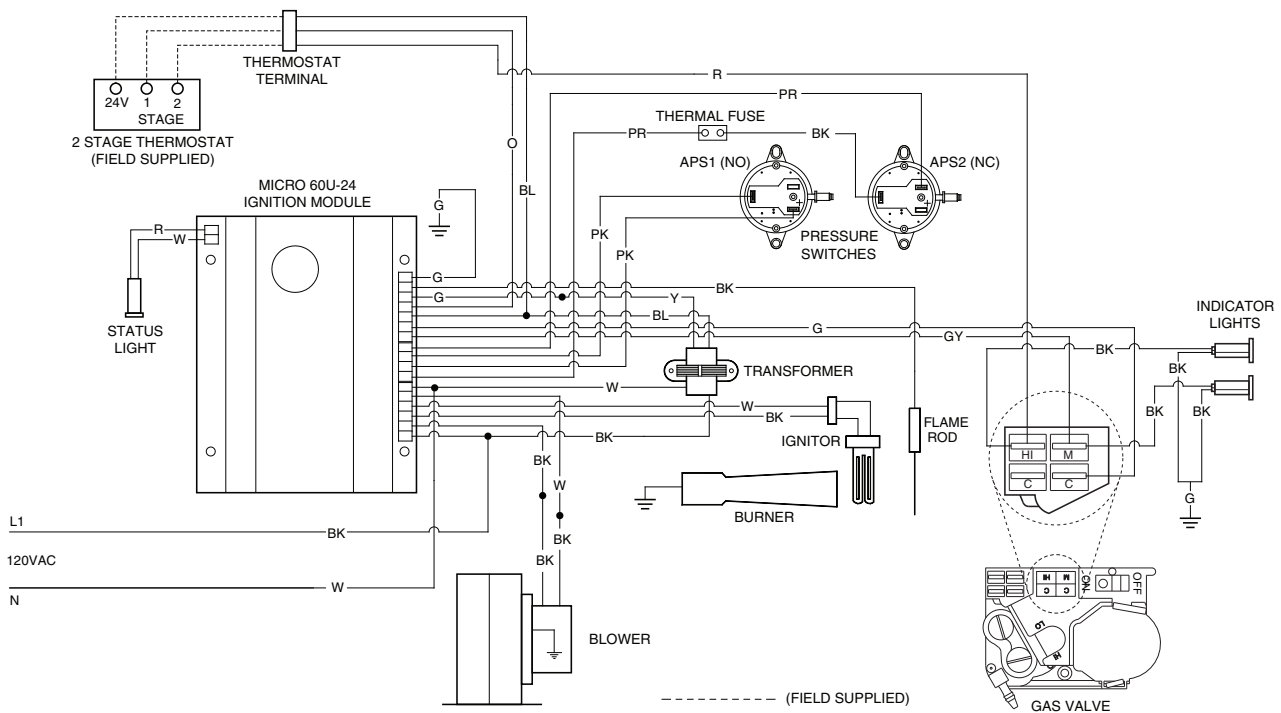
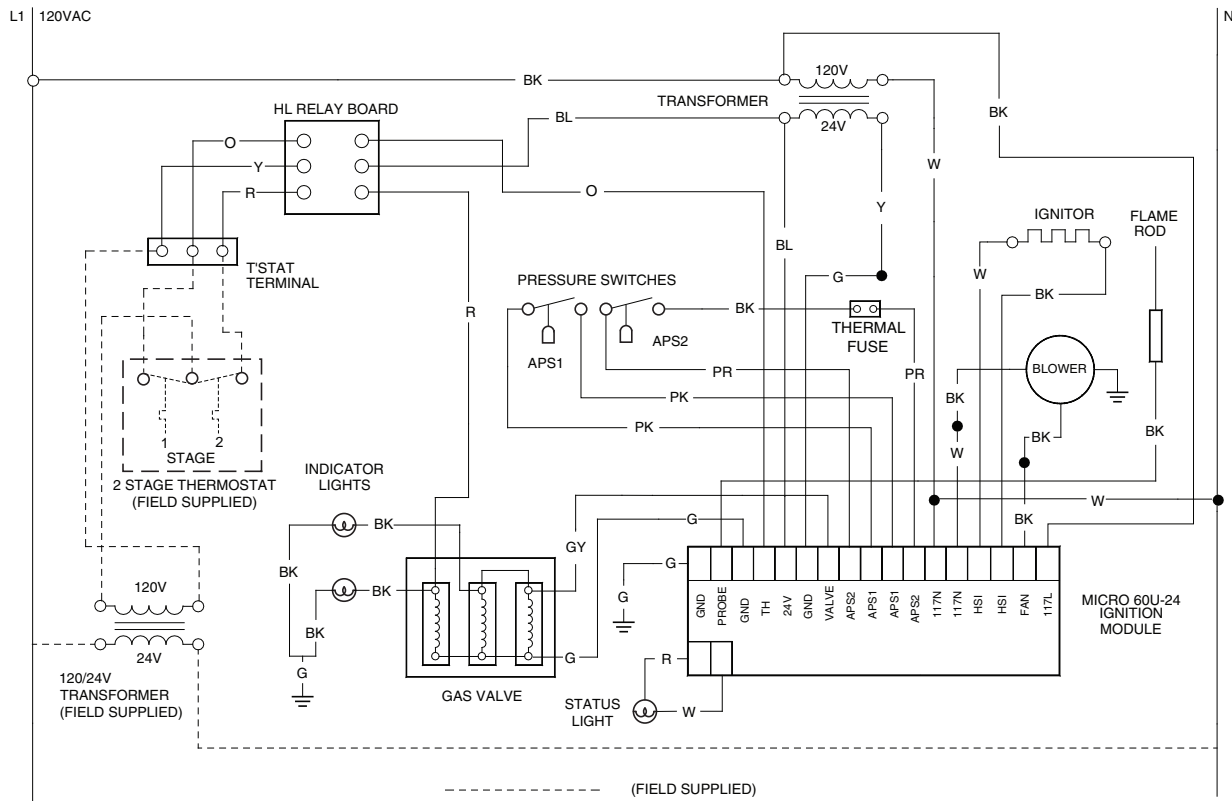
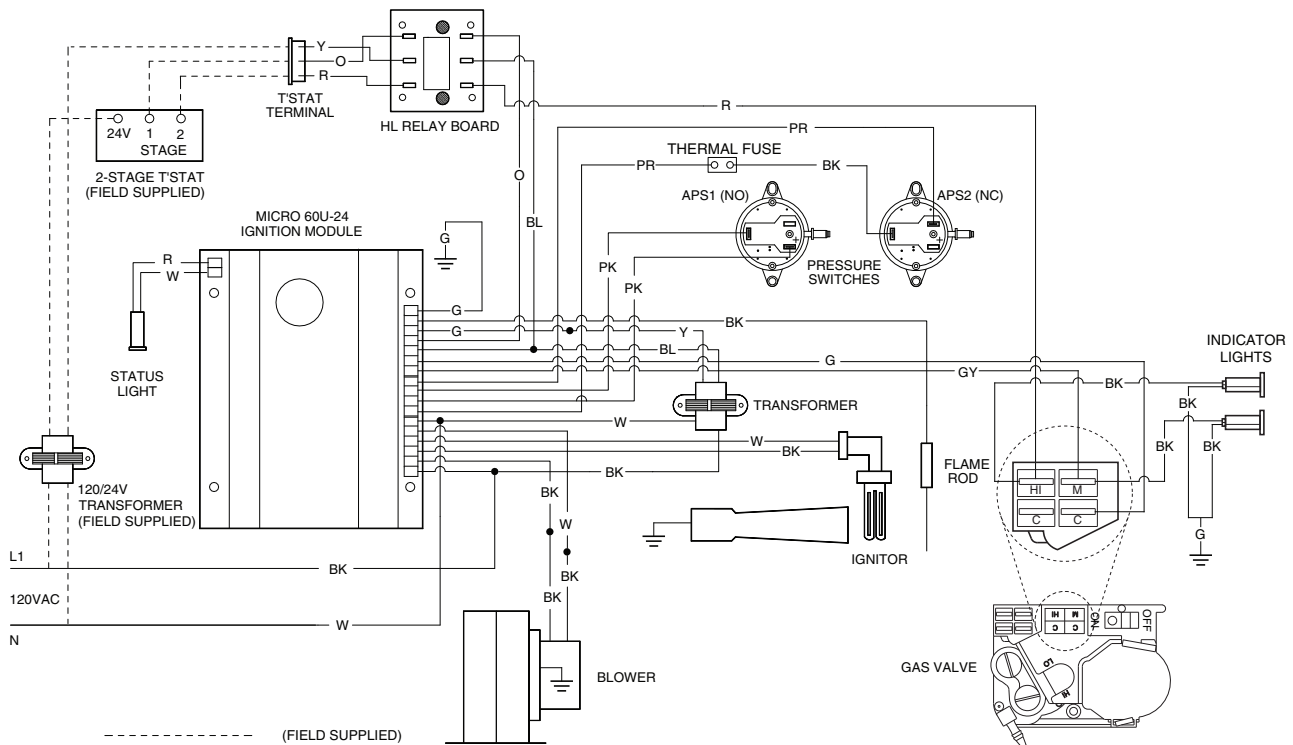

Figure 3.3 • LD Series Alternative Wiring Diagrams

A. LD Series Micro 60U-24 Ladder Diagram - With Relay Board



B. LD Series Micro 60U-24 Block Diagram - With Relay Board



4.0 Operation

⚠ WARNING



This appliance does not have a pilot ignition. It is equipped with an ignition device which automatically lights the burner. **Do not** attempt to light the system by hand.

BEFORE OPERATING, smell all around the appliance area for gas. Be sure to smell next to the floor because some gas is heavier than air and will settle to the floor. Refer to page 1 “If you smell gas” and on safety label affixed to the heater.

Do not use this appliance if any part has been under water. Immediately call a qualified service technician to inspect the appliance and to replace any part of the control system and any gas control which has been under water.



Operating Instructions

⚠ WARNING



Use only your hand to turn the manual shutoff. Never use tools. If the knob will not turn by hand, don't try to repair it; call a qualified technician. Force or attempted repair may result in a fire or explosion.

Lighting Procedures:

- ① **STOP!** Read the safety information above.
- ② Set the thermostat to the lowest setting.
- ③ Turn OFF all electrical power to the appliance.
- ④ Turn manual shutoff clockwise  to “OFF”.
- ⑤ Wait five (5) minutes to clear out any gas. If you smell gas STOP! Follow the safety information found on page 1 “If you smell gas” and on safety label affixed to the heater. If you do not smell gas, proceed to step 6.
- ⑥ Turn manual shutoff knob counterclockwise  to “ON”.
- ⑦ Turn ON all electrical power to the appliance.
- ⑧ Set thermostat to desired setting.
- ⑨ If the appliance will not operate, follow instructions below to turn OFF gas to the appliance and call your service technician or gas supplier.

Shutdown Procedures:

- ① Set the thermostat to the lowest setting.
- ② Turn OFF all electrical power to the appliance if service is to be performed.
- ③ Turn manual shutoff knob clockwise  to “OFF”. **Do not** force.

⚠ WARNING



This heater must be installed and serviced by trained gas installation and service personnel only.

Do not bypass any safety features or the heater's built in safety mechanisms will be compromised.

Sequence of Operation

Standby: The MICRO 60U-24 CONTROL continually checks for internal faults, circuit integrity and relay contact positioning.

Starting Circuit: Upon a call for heat, the control verifies that the burner and exhaust pressure switches are in their proper positions. The control energizes the fan. Once operational static pressure is achieved, the burner pressure switch will close initiating the ignition sequence. The hot surface igniter is powered and the gas valve opens after 45 seconds. If the flame is not sensed, the heater will attempt to re-ignite for a total of 3 trials for ignition before proceeding to soft lockout.

Low Fire Running Circuit: After ignition, the flame rod monitors burner flame. If sense of flame is lost, the control closes the gas valve within one second and a new trial sequence (identical to the starting sequence) is initiated. If flame sense is not established within 8.5 seconds, the heater will attempt two additional ignition sequences before proceeding to soft lockout. The control can be reset by briefly interrupting the power source.

High Fire Running Circuit: The second stage on the gas valve is powered directly from the second stage of the thermostat. In order for high fire to engage, low fire must be energized as well. The thermostat determines which stage to maintain for the desired comfort level.

Shut Down: When the thermostat is satisfied, the fan will enter a two (2) minute post-purge cycle.

Diagnostics

Lockout:

The controls will automatically lockout the heater system when an external or system fault occurs. There are two types of lockout:

Soft Lockout: The heater will attempt to light three times. In the event of a failed attempt to light, (gas pressure, valve, no flame sense etc.), the heater will enter a soft lockout period for 30 minutes and then attempt to light three more times before entering hard lockout mode.

Hard Lockout: If proof of flame is not established, a component failure occurs or blockages are evident, the heater will enter hard lockout. If lockout occurs, the control can be reset by briefly interrupting the power source. Refer to Chart 4.1 below for a description of LED codes.

Externally located operational indicator lights are provided to assist in troubleshooting of the heater. Refer to pages 40-43 for additional troubleshooting.

Figure 4.1 • Operational Indicator Lights

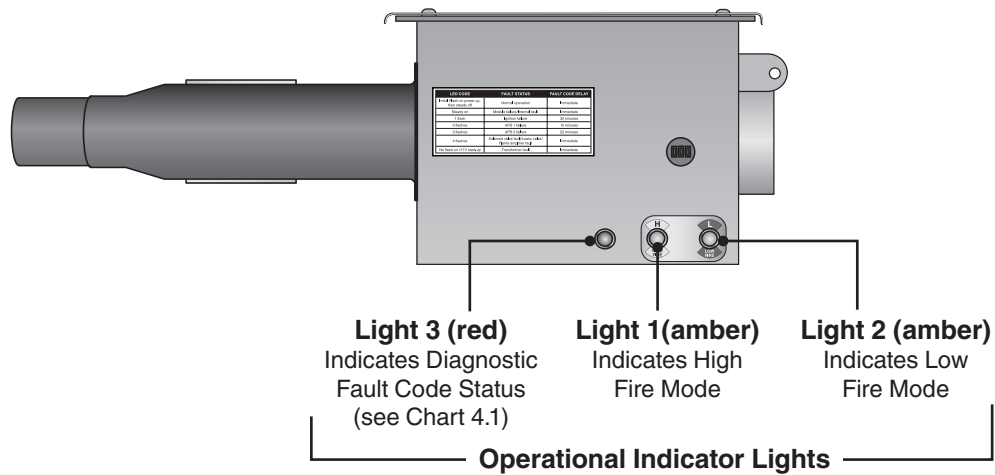
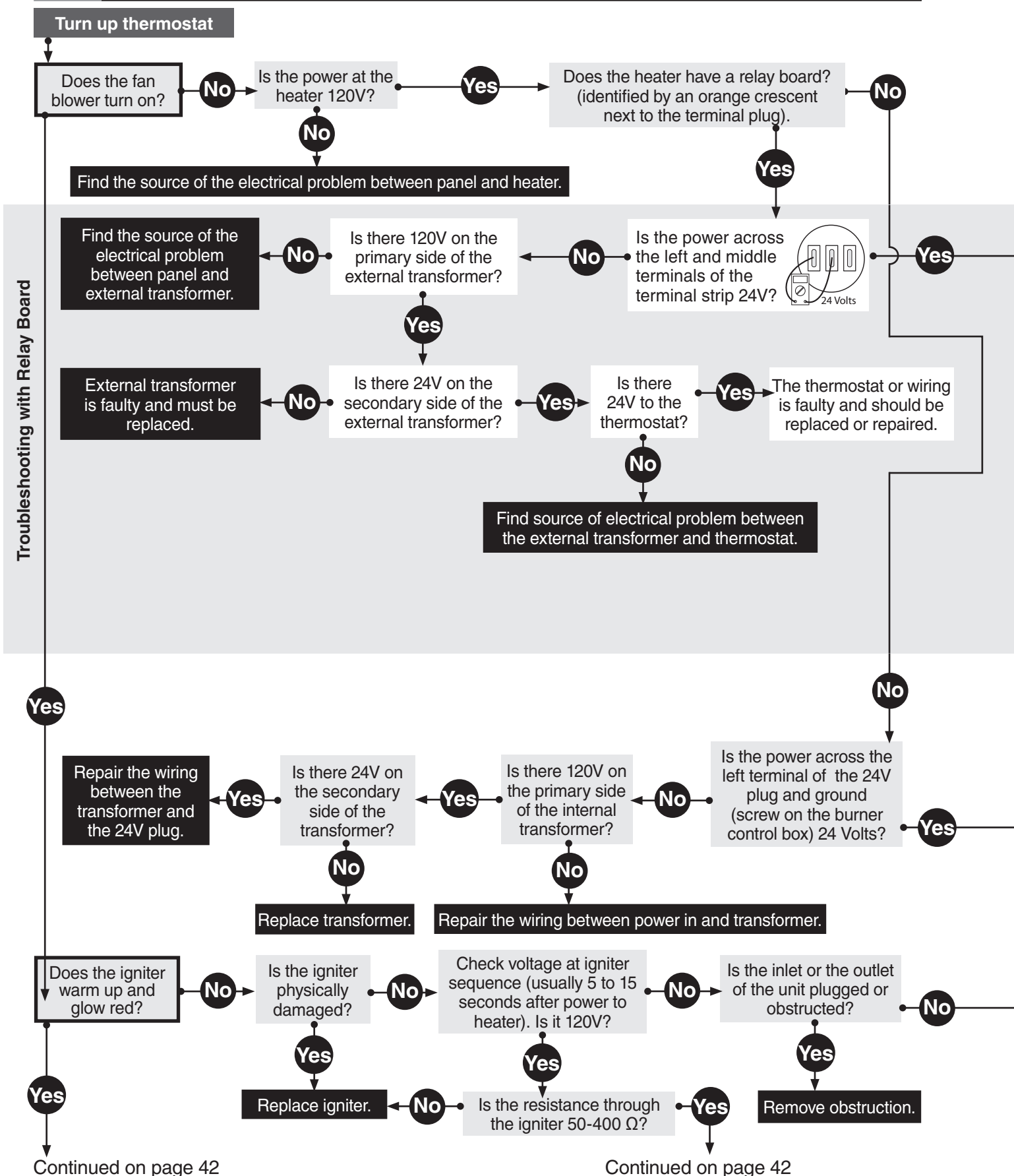

Chart 4.1 • LED Fault Code Status

LED CODE	FAULT STATUS	FAULT CODE DELAY*
Initial Flash on power up, then steady off	Normal operation	Immediate
Steady on	Module failure/Internal fault	Immediate
1 flash	Ignition failure	32 minutes
2 flashes	APS 1 failure	12 minutes
3 flashes	APS 2 failure	22 minutes
4 flashes	Solenoid valve fault/Leaky valve/ Flame amplifier fault	Immediate
No flash on 117V start-up	Transformer fault	Immediate

*Some LED codes have a time delay before the LED will flash.

5.0 Maintenance



Continued on page 42

Continued on page 42

NOTICE

Bypassing any switch is intended for testing purposes only. Do not leave switch bypassed during normal operation or the heater's built-in safety mechanisms will be compromised.

Key

Without Relay Board:

- Start Question
- Process Question
- Corrective Action

With Relay Board:

- Process Question
- Corrective Action

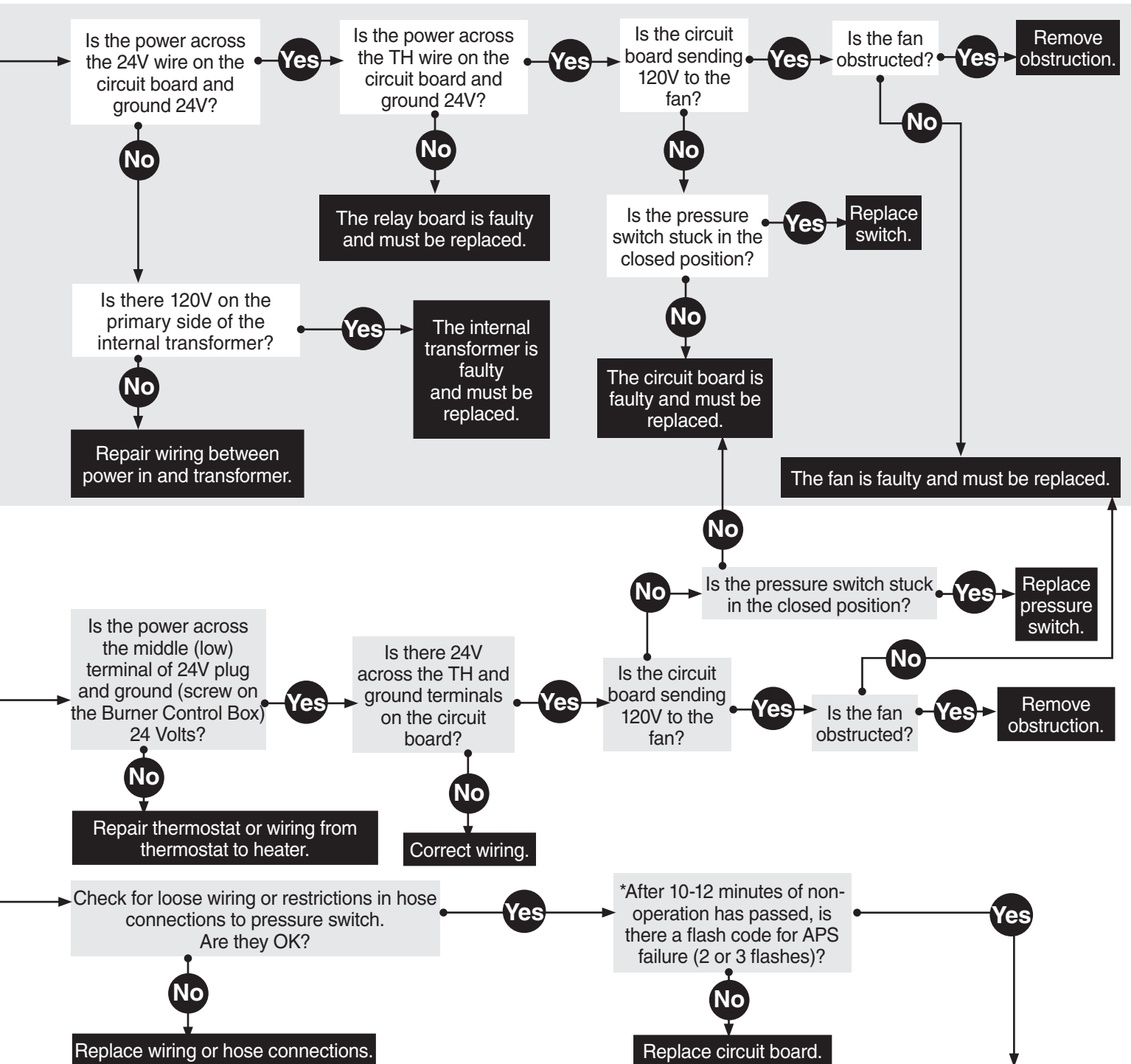

* Refer to LED diagnostic Fault Code Chart.

Continued on page 43

Continued from page 40

Continued from page 40

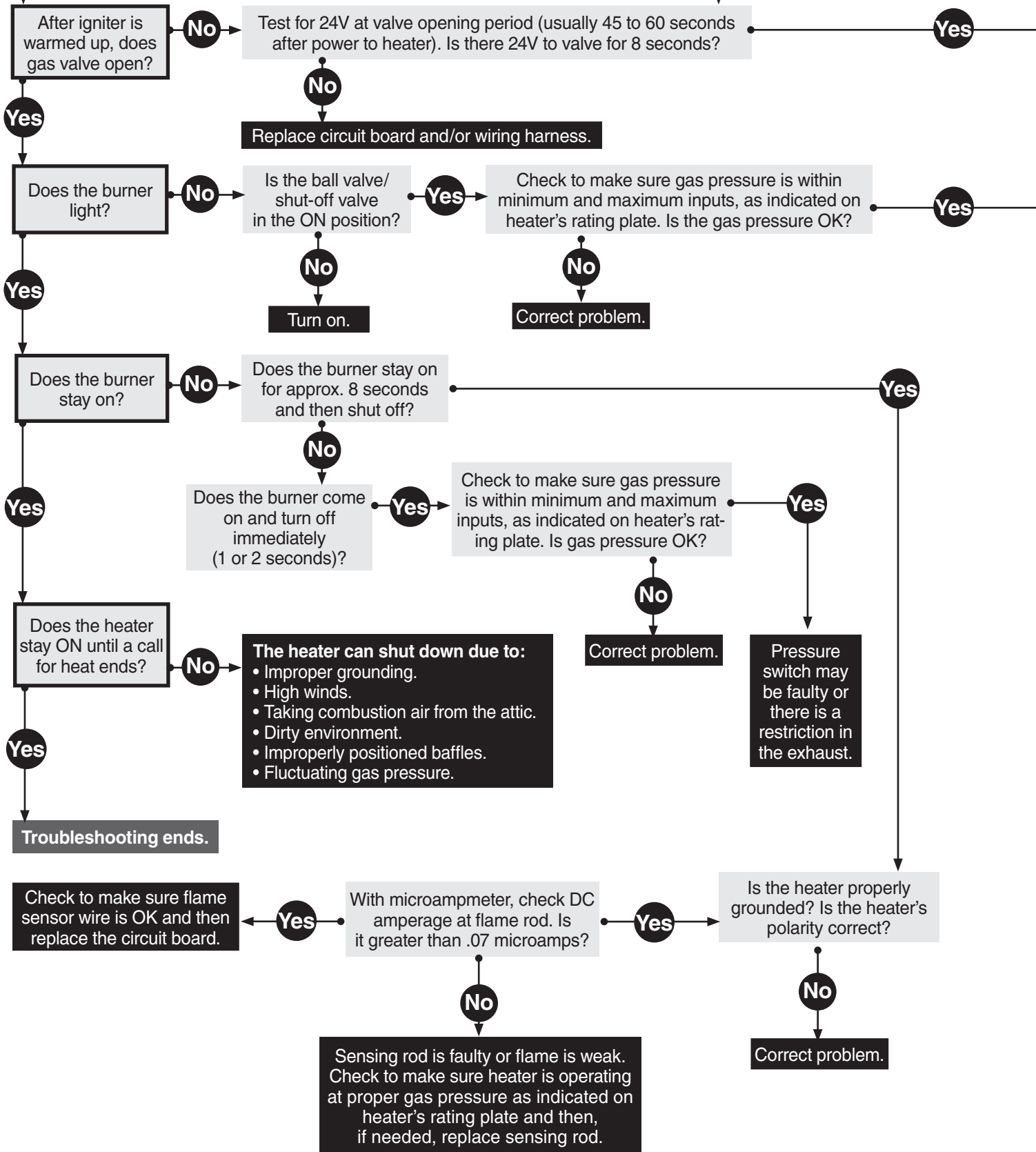

Continued from page 41

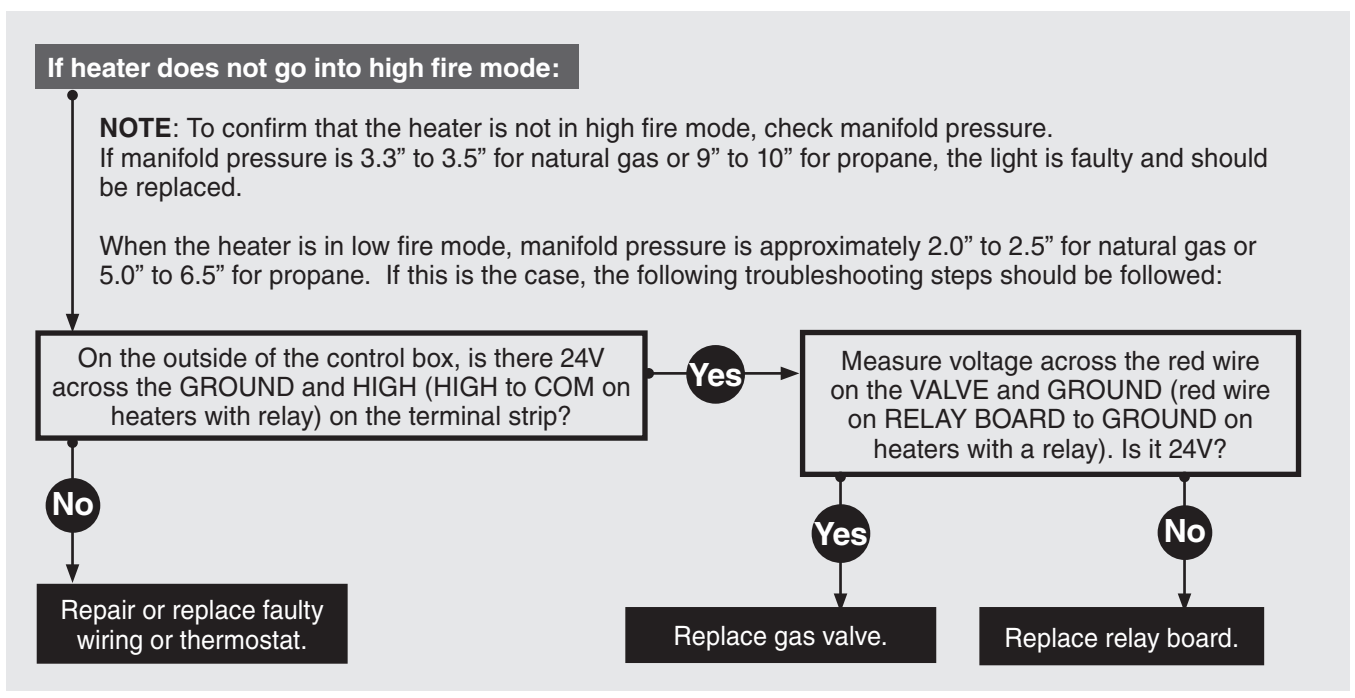
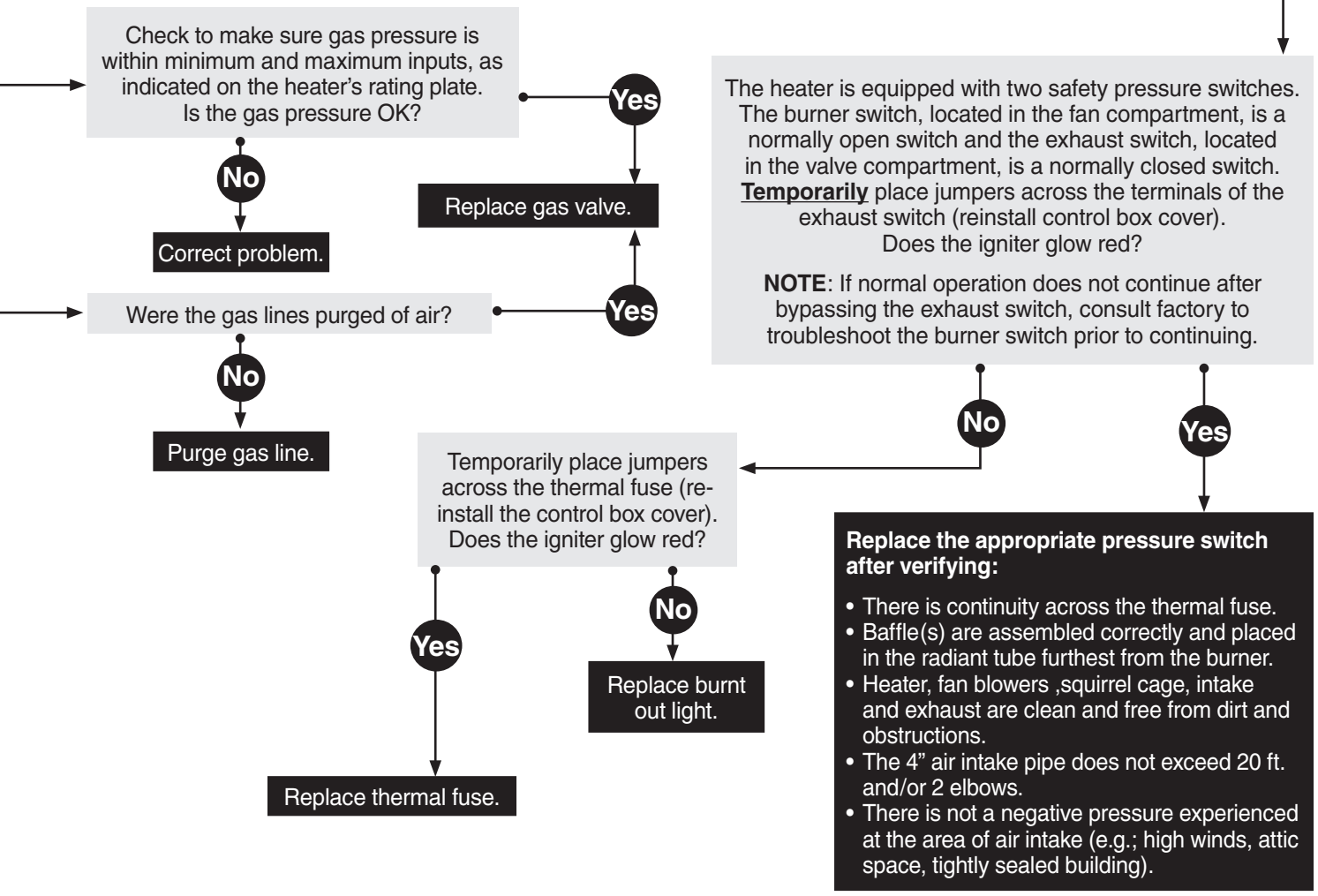

Figure 5.1 • Burner Assembly Components

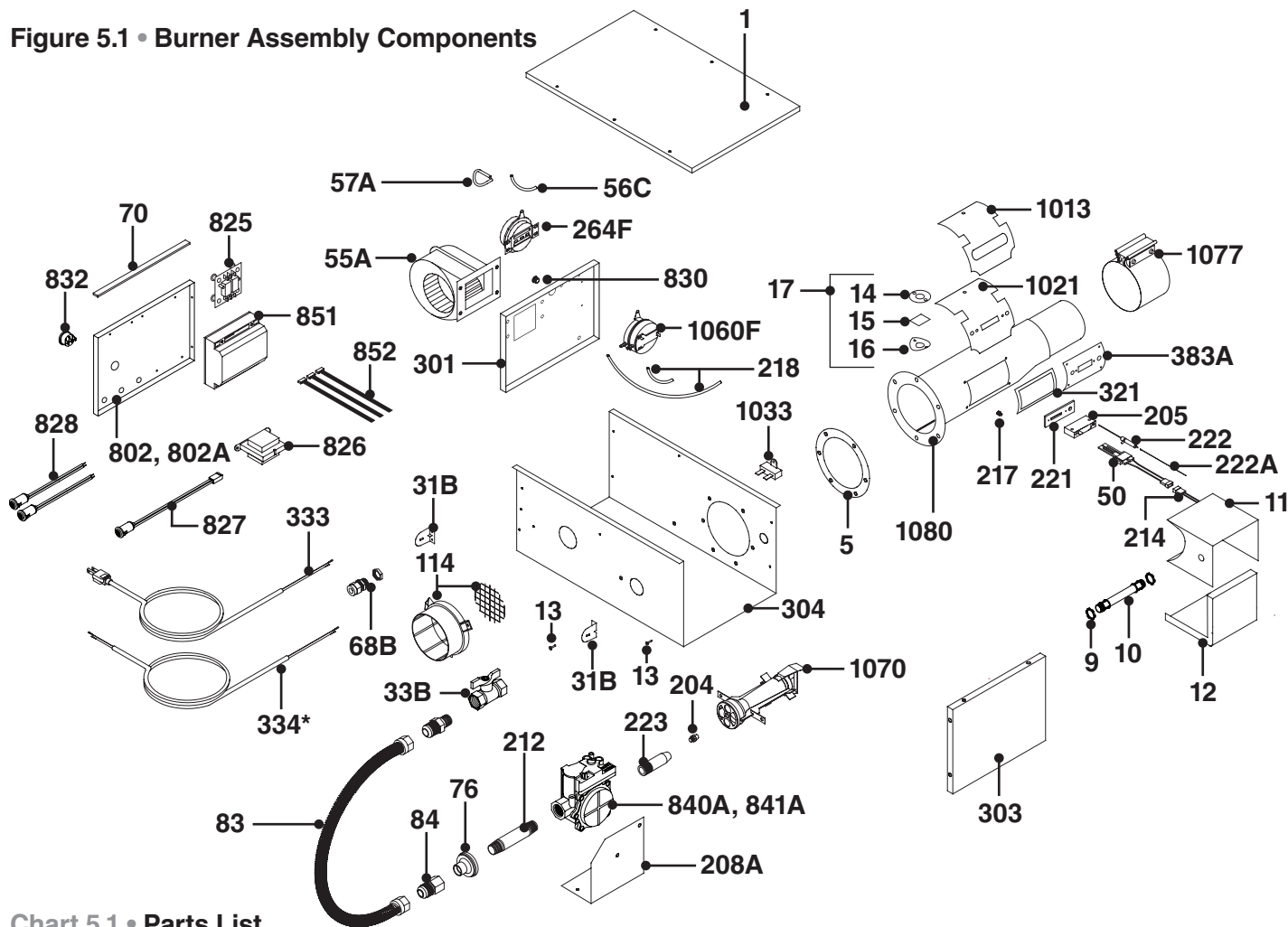

Chart 5.1 • Parts List

Part No.	Description	Part No.	Description
TP-1	Control Box Cover	TP-57A	1/4 in. Pressure Tube
TP-5	Flange Gasket	TP-68B	Strain Relief Bushing
TP-9	Conduit Coupling	TP-70	Control Box Cover Gasket (per foot*)
TP-10	Conduit 4 in. x 1/2 in.	TP-76	Rubber Grommet
TP-11	Hot Surface Igniter Box	TP-83	24 in. Stainless Steel Flexible Gas Connector
TP-12	Hot Surface Igniter Box Cover	TP-105	Aluminum Reflector End Cap
TP-13	8 x 1/2 in. Self-Drilling Screw	TP-106	Reflector End Cap Clips (8 pcs.)
TP-14	Sight Glass Gasket	TP-112	60 in. Aluminum Reflector
TP-15	Sight Glass	TP-114	Plastic Air Orifice with Screen
TP-16	Sight Glass Washer	TP-204	Gas Orifice (consult factory)
TP-17	Sight Glass Kit	TP-205	Hot Surface Igniter Holder
TP-20C	120 in. Aluminum Reflector	TP-208A	Gas Valve Mounting Bracket
TP-20D*	120 in. Stainless Steel Reflector	TP-212	1/2" x 3" Pipe Nipple
TP-31B	Control Box Mounting Bracket	TP-214	Hot Surface Igniter Wiring Harness
TP-33B	1/2 in. Shut-Off Ball Valve/Inlet Tap	TP-217	Pressure Switch Barb
TP-50	Hot Surface Igniter	TP-218	Differential Switch Vinyl Sensing Tube (exhaust)
TP-55A	Fan Blower	TP-221	Hot Surface Igniter Holder Gasket
TP-56C	1/4 in. Atmospheric Vinyl Tube	TP-222	Flame Rod

* Optional

**6 feet total required to cover outer edges of the burner control box.

Figure 5.2 • Tube & Reflector Components

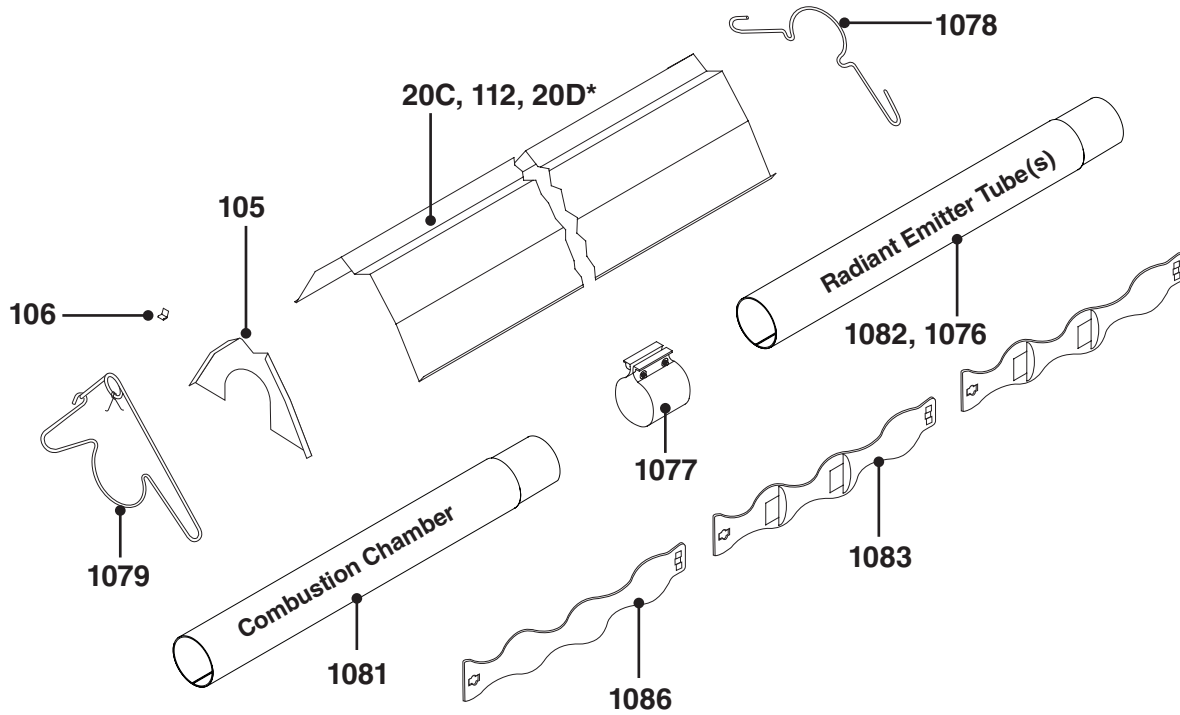

Part No.	Description	Part No.	Description
TP-222A	Flame Rod Wire	TP-840A	36G54-224 Gas Valve - Natural Gas Assembly
TP-223	Gas Manifold	TP-841A	36G54-226 Gas Valve - LP Gas Assembly
TP-264F	Normally Open Burner Pressure Switch	TP-851	Micro-60-24 Diagnostic Circuit Board
TP-301	Burner Control Box Center Panel	TP-852	3-Piece Wire Harness Set for Micro 60 Board
TP-303	End Panel, Right	TP-1013	Ignition Cover Plate
TP-304	Burner Control Box Outer Shell	TP-1021	Ignition Cover Plate Gasket
TP-321	Ignition Plate Gasket	TP-1033	Thermal Cutoff Fuse
TP-333	Black 60 in. 120V 3-Prong Power Cord	TP-1060F	Normally Closed Exhaust Pressure Switch
TP-334*	Yellow 24V Control Wire (when applicable)	TP-1070	Burner
TP-383A	Hot Surface Igniter Plate	TP-1076	3 in. O.D. 5 ft. Coated Aluminized Tube
TP-802	End Panel, Left (models with relay board)	TP-1077	3 in. Tube Clamp
TP-802A	End Panel, Left (models without relay board)	TP-1078	3 in. Reflector Center Support (RCS)
TP-825*	Optional HLRB Relay Board	TP-1079	3 in. Wire Hanger with Tension Spring
TP-826	40VA Transformer	TP-1080	4"x16" HSI Burner Tube (fittings included)
TP-827	Red LED Display Diagnostic Light	TP-1081	10 ft. Titanium Coated Combustion Tube
TP-828	Yellow Operational Indicator Lights	TP-1082	10 ft. Coated Aluminized Tube
TP-830	Divider Grommet	TP-1083	36 in. Pressure Baffle (2 required)
TP-832	Thermostat Terminal Strip	TP-1086	36 in. Heat Baffle Section

⚠ WARNING



Personal injury or death may result if maintenance is not performed by properly trained gas installer or service personnel. Contact the installing distributor or place of purchase for service. **Do not operate heating system if repairs are necessary.**



Allow heater to cool prior to servicing.

Disconnect power to heater before servicing.

Use protective glasses when maintaining the heater.

Routine Inspection:

At least once per year, the heating system should be inspected and serviced by trained gas installation and service personnel only. This inspection should be performed at the beginning of the heating season to insure that all heater components are in proper working order and that the heating system operates at peak performance. Particular attention should be paid to the following items.

- **Blower Motor:** Annual oiling of the blower motor with SAE 20 oil will extend bearing life significantly. Ensure that the squirrel cage in the blower is kept clean. If dirt becomes a problem, installation of outside air intake ducts for combustion is recommended.
- **Vent pipe system:** Check the outside termination and the connections at the heater. Inspect the vent exhausts for leakage, damage, fatigue, corrosion and obstructions. If dirt becomes a problem, installation of outside air intake ducts for combustion is recommended.
- **Combustion air intake system** (when applicable): Check for blockage and/or leakage. Check the outside termination and the connection at the heater.
- **Heat exchangers:** Check the integrity of the heat exchangers. Replace if there are signs of structural failure. Check for corrosion and/or buildup within the tube exchanger passageways.
- **Burner:** Check for proper ignition, burner flame and flame sense. Flame should extend directly outward from burner without floating or lifting.
- **Wiring:** Check electrical connections for tightness and/or corrosion. Check wires for damage.
- **Gas Connection:** Inspect the integrity of the gas connection to the heater. Check for leaks, damage, fatigue or corrosion. Do not operate if repairs are necessary and turn off gas supply to the heater. Contact service personnel.
- **Reflectors:** To maintain effective infrared heating, always keep both sides of the reflector clean. Maintenance can vary significantly depending on the environment. Dirt and dust can be vacuumed or wiped with a soap and water solution. Use metal polish if the reflectors are severely dirty.

Contact service personnel if repairs are necessary. Do not operate unit.

Limited Warranty Terms and Conditions

One-Year Limited Warranty. Radiant Tube Heaters covered in this manual, are warranted by Detroit Radiant Products Company to the original user against defects in workmanship or materials under normal use for one year after date of purchase. Any part which is determined to be defective in material or workmanship and returned to an authorized service location, as Detroit Radiant Products Company designates, shipping costs prepaid, will be, as the exclusive remedy, repaired or replaced at Detroit Radiant Products Company's option. For limited warranty claim procedures, see PROMPT DISPOSITION below. This limited warranty gives purchasers specific legal rights which vary from jurisdiction to jurisdiction.

Additional Limited Warranty. In addition to the above mentioned one-year warranty, Detroit Radiant Products Company warrants the original purchaser an additional extension on the combustion chamber, radiant tubes and stainless steel burner. This extension excludes electrical/purchased components.

General Conditions. The Company will not be responsible for labor charges for the analysis of a defective condition of the heater or for the installation of replacement parts. The warranties provided herein will not apply if the input of the heater exceeds the rated input at time of manufacturing or if the heater in the judgment of the Company has been subjected to misuse, excessive dust, improper conversion, negligence, accident, corrosive atmospheres, excessive thermal shock, excessive vibration, physical damage to the heater, alterations by unauthorized service personnel, operation contrary to the Company's instructions or if the serial number has been altered, defaced, or removed. The Company shall not be liable for any default or delay in the performance of these warranties caused by contingency beyond its control, including war, government restriction or restraints, strikes, fire, flood, short or reduced supply of raw materials, or parts.

Limitation of Liability. To the extent allowable under applicable law, Detroit Radiant Products Company's liability for consequential and incidental damages is expressly disclaimed. Detroit Radiant Products Company's liability in all events is limited to and shall not exceed the purchase price paid.

Warranty Disclaimer. Detroit Radiant Products Company has made a diligent effort to provide product information and illustrate the products in this literature accurately; however, such information and illustrations are for the sole purpose of identification, and do not express or imply a warranty that the products are merchantable, or fit for a particular purpose, or that the products will necessarily conform to the illustrations or descriptions. Except as provided below, no warranty or affirmation of fact, expressed or implied, other than as stated in the "LIMITED WARRANTY" above is made or authorized by Detroit Radiant Products Company.

Product Suitability. Many jurisdictions have codes and regulations governing sales, construction, installation, and/or use of products for certain purposes, which may vary from those in neighboring areas. While Detroit Radiant Products Company attempts to assure that its products comply with as many codes, it cannot guarantee compliance, and cannot be responsible for how the product is installed or used. Before purchase and use of a product, review the product applications, and all applicable national and local codes and regulations, and be sure that the product, installation, and use will comply with them. Certain aspects of disclaimers are not applicable to consumer products:







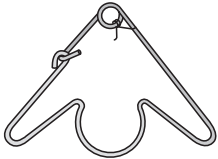

e.g., (a) some jurisdictions do not allow the exclusion or limitation of incidental or consequential damages, so the above limitation or exclusion may not apply to you: (b) also, some jurisdictions do not allow a limitation on how long an implied warranty lasts, consequently the above limitation may not apply to you: and (c) by law, during the period of this limited warranty, any implied warranties of implied merchantability or fitness for a particular purpose applicable to consumer products purchased by consumers, may not be excluded or otherwise disclaimed.

Prompt Disposition. Detroit Radiant Products Company will make a good faith effort for prompt correction or other adjustment with respect to any product which proves to be defective within limited warranty. For any product believed to be defective within limited warranty, first write or call dealer from whom the product was purchased. Dealer will give additional directions. If unable to resolve satisfactorily, write to Detroit Radiant Products Company at address below, giving dealer's name, address, date and number of dealer's invoice, and describe the nature of the defect. Title and risk of loss pass to buyer on delivery to common carrier. If product was damaged in transit to you, file claim with carrier.

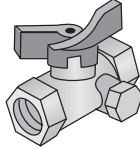
Registration. Register on-line at www.detroitradiant.com/warranty.

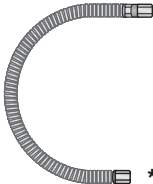
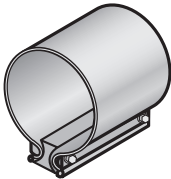
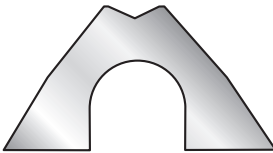
Kit Contents Check List

Chart 5.2 • Kit Contents for LD Series - Reference the length column for your model.

LD Series Kit Contents					
TP-1079 30" Hanger with Reflector Tension Spring 	TP-1078 3" Reflector Center Support (RCS) 	TP-33B 1/2" Shut-Off Valve (Ball Valve & Inlet Tap) 	TP-106 Reflector End Cap Clips 		
TP-83 24" Stainless Steel Flexible Gas Connector 	TP-1077 3" Tube Clamp 	TP-105 Reflector End Cap 	LD Series Installation, Operation and Maintenance Manual F/N: LIOLD 		
TP-1083 3" x 33" Stainless Steel Tabbed Pressure Baffles 		TP-1086 3" x 33" Stainless Steel Heat Baffle 			
Part No.	Description	10 ft.	15 ft.	20 ft.	30 ft.
TP-33B	1/2" Shut-Off Valve & Inlet Tap	1	1	1	1
TP-83	24" S.S. Flexible Gas Connector	1	1	1	1
TP-105	Reflector End Cap	2	2	2	2
TP-106	Reflector End Cap Clips	8	8	8	8
TP-1077	3" Tube Clamp	1	2	2	3
TP-1078	3" Reflector Center Support	1	1	2	3
TP-1079	3" Hanger w/ Tension Spring	2	3	3	4
TP-1083	3" x 33" Stainless Steel Tabbed Pressure Baffles	2	2	2	2
TP-1086	3" x 33" Stainless Steel Heat Baffle	1	1	1	1
LIOLD	LD Series Installation Manual	1	1	1	1
Filled By:					

Approvals

- ANSI Z83.20b and CSA 2.34.
- Indoor approval.
- Certain models are residentially Certified to CSA No. 7-89
- Outdoor approval with OD-Kit.
- Commercial approval.

Limited Warranty

- 1 year - Burner box components.
- 3 years - Combustion and radiant tubes.
- 5 years - Stainless steel burner.
- See page 47 for terms and conditions.



© 2009 Detroit Radiant Products Co.
 21400 Hoover Road • Warren, MI 48089
 Phone: (586) 756-0950 Fax: (586) 756-2626
 www.detroitradiant.com • sales@drp-co.com