

**Detroit Radiant Products Co.**

# DR Series Manual

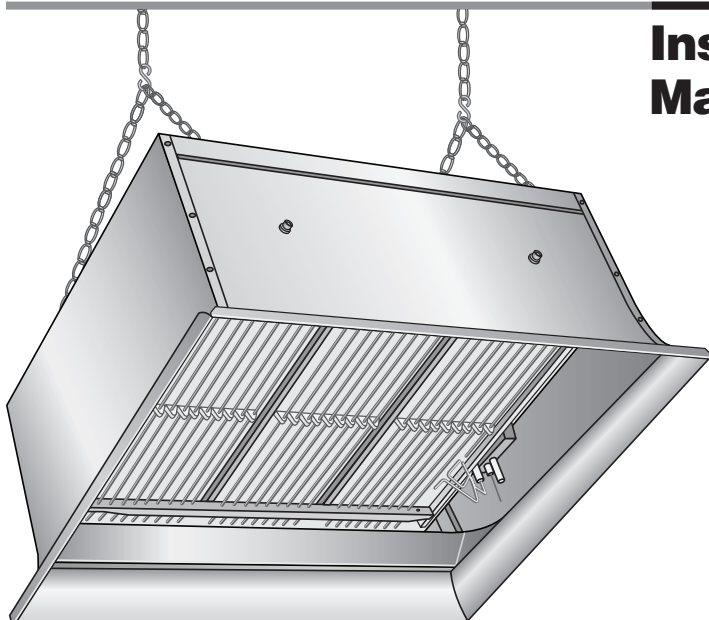

## Installation, Operation Maintenance and Parts



All persons involved with the installation, operation and maintenance of the heater system must read and understand the information in this manual.

### ⚠ WARNING



Improper installation, adjustment, alteration, service or maintenance can cause property damage, injury or death. Read and understand the installation, operating and maintenance instructions thoroughly before installing or servicing this equipment.

Only trained, qualified gas installation and service personnel may install or service this equipment. Failure to comply could result in personal injury, asphyxiation, death, fire and/or property damage.



In locations used for the storage of combustible materials, signs must be posted to specify the maximum permissible stacking height to maintain the required clearances from the heater to the combustibles. Signs must either be posted adjacent to the heater thermostats or in the absence of such thermostats, in a conspicuous location.

#### **Not for residential use!**

This heater is not approved in any residential application. This includes (but is not limited to) the home, living quarters, attached garages, etc. Installation in residential indoor spaces may result in property damage, asphyxiation, serious injury or death.

### **For Your Safety**

#### **If you smell gas:**

- Do not try to light any appliance.
- Do not touch any electrical switch.
- Do not use any phone in your building.
- Immediately call your gas supplier from a neighbor's phone.
- Follow the gas supplier's instructions.
- If you cannot reach your gas supplier, call the fire department.

**Keep these instructions for future reference.**

# Contents

---

<b>1.0 Safety</b> .....	<b>3</b>
Safety Symbols .....	3
Applications .....	3
Clearance to Combustibles .....	4
Gas Connection .....	6
Standards, Certifications and Government Regulations .....	6
Safety Signs and Labels .....	8
<b>2.0 Installation</b> .....	<b>9</b>
Design .....	9
Heater Placement .....	10
Heater Mounting .....	12
Ventilation .....	14
Gas Supply .....	15
Electrical .....	17
<b>3.0 Operation</b> .....	<b>19</b>
<b>4.0 Maintenance</b> .....	<b>20</b>
Troubleshooting Guide .....	21
Heater Assembly Components .....	22
Parts Listing .....	23
<b>5.0 Limited Warranty</b> .....	<b>24</b>

# 1.0 Safety

## ⚠ WARNING



Improper installation, adjustment, alteration, service or maintenance can cause property damage, serious injury or death. Read and understand the installation, operating and maintenance instructions thoroughly before installing or servicing this equipment. Only trained, qualified gas installation and service personnel may install or service this equipment.

### Safety Symbols

Safety is the most important consideration during installation, operation and maintenance of the infra-red heater. You will see the following symbols and signal words when there is a hazard related to safety or property damage.

#### ⚠ WARNING

**Warning** indicates a potentially hazardous situation which, if not avoided, could result in death or injury.

#### ⚠ CAUTION

**Caution** indicates a potentially hazardous situation which, if not avoided, could result in minor or moderate injury.

#### NOTICE

**Notice** indicates a potentially hazardous situation which, if not avoided, could result in property damage.

### Applications

This is not an explosion proof heater. Consult your local fire marshall, insurance carrier and other authorities for approval of the proposed installation.

#### Commercial / Industrial (Indoor Only)

Infra-red heaters are designed and certified for use in industrial and commercial buildings such as warehouses, manufacturing plants, aircraft hangars and vehicle maintenance shops. For maximum safety, the building must be evaluated for potential hazards before installing the heater system. A critical safety factor to consider before installation is the clearance to combustibles.

#### Non-Residential

This heater is **NOT** approved for use in any residential application. This includes, but not limited to, attached garages, living quarters, solariums, etc. Consult the local fire marshal and/or insurance provider if unsure of your application.

## ⚠ WARNING



#### Not For Residential Use.

Installation of an infra-red heater system in residential indoor spaces, RV's, mobile homes, etc. may result in property damage, asphyxiation, fire, serious injury or death.

## Clearance to Combustibles

### ⚠ WARNING



Improperly connected gas lines may result in serious injury or death, explosion, poisonous fumes, toxic gases, asphyxiation. Connect gas lines in accordance to national, state, provincial and local codes.

Placement of explosive objects, flammable objects, liquids and vapors close to the heater may result in explosion, fire, property damage, serious injury or death. Do not store, or use, explosive objects, liquids and vapor in the vicinity of the heater.

Failure to comply with the published clearances to combustibles could result in personal injury, death and/or property damage.

### ⚠ CAUTION



Signs shall be posted specifying the maximum permissible stacking height in order to maintain clearances to combustibles.

#### Hazards Include:

For maximum safety the building must be evaluated for hazards before installing the heater system. Examples include, but are not limited to:

- Gas and electrical lines
- Combustible and explosive materials
- Chemical storage areas
- Areas of high chemical fume concentrations
- Provisions for accessibility to the heater
- Adequate clearances around air openings
- Combustion and ventilating air supply
- Vehicle parking areas
- Vehicles with lifts or cranes
- Storage areas with stacked materials
- Lights
- Sprinkler heads
- Overhead doors and tracks
- Dirty, contaminated environment

A critical safety factor to consider before installation is the clearances to combustibles. Clearance to combustibles is defined as the minimum distance you must have between the infra-red surface, or reflector, and the combustible item. Considerations must also be made for moving objects around the infra-red heater. The following is a partial list of items to maintain clearances from:

#### Combustible Items Include:

- Wood
- Paper
- Fabric
- Chemicals
- Wall or roof insulation

#### Moving Objects Include:

- Overhead doors
- Vehicles on lifts
- Cranes
- Hoists
- Car wash equipment

When installing the infra-red heater system, the minimum clearances to combustibles must be maintained. These distances are shown in Chart 1.1 and on the heater. If you are unsure of the potential hazards, consult your local fire marshal, fire insurance carrier or other qualified authorities on the installation of gas fired infra-red heaters for approval of the proposed installation.

Chart 1.1 • Clearance to Combustibles in Inches (see Figure 1.1)

Model No.	Sides	Back	Top	Below/Front
DR 30 (S)	30	18	28	72
DR 45	30	18	28	72
DR 50	30	18	34	72
DR 55	32	18	40	72*
DR 60	32	18	40	72*
DR 75	48	30	42	98
DR 80	48	30	42	98
DR 85	48	30	42	98
DR 90	48	30	42	98
DR 95	48	30	52	120
DR 100	48	30	52	120
DR 130	48	30	52	120
DR 160	50	32	60	132

\* This clearance is 80 in. when the heater is fitted with a parabolic reflector.

**NOTE:** If the heater is mounted beneath a non-combustible surface, a 24 in. minimum top clearance must be maintained from the top of the heater to prevent overheating the controls.

Figure 1.1 • Clearance to Combustibles

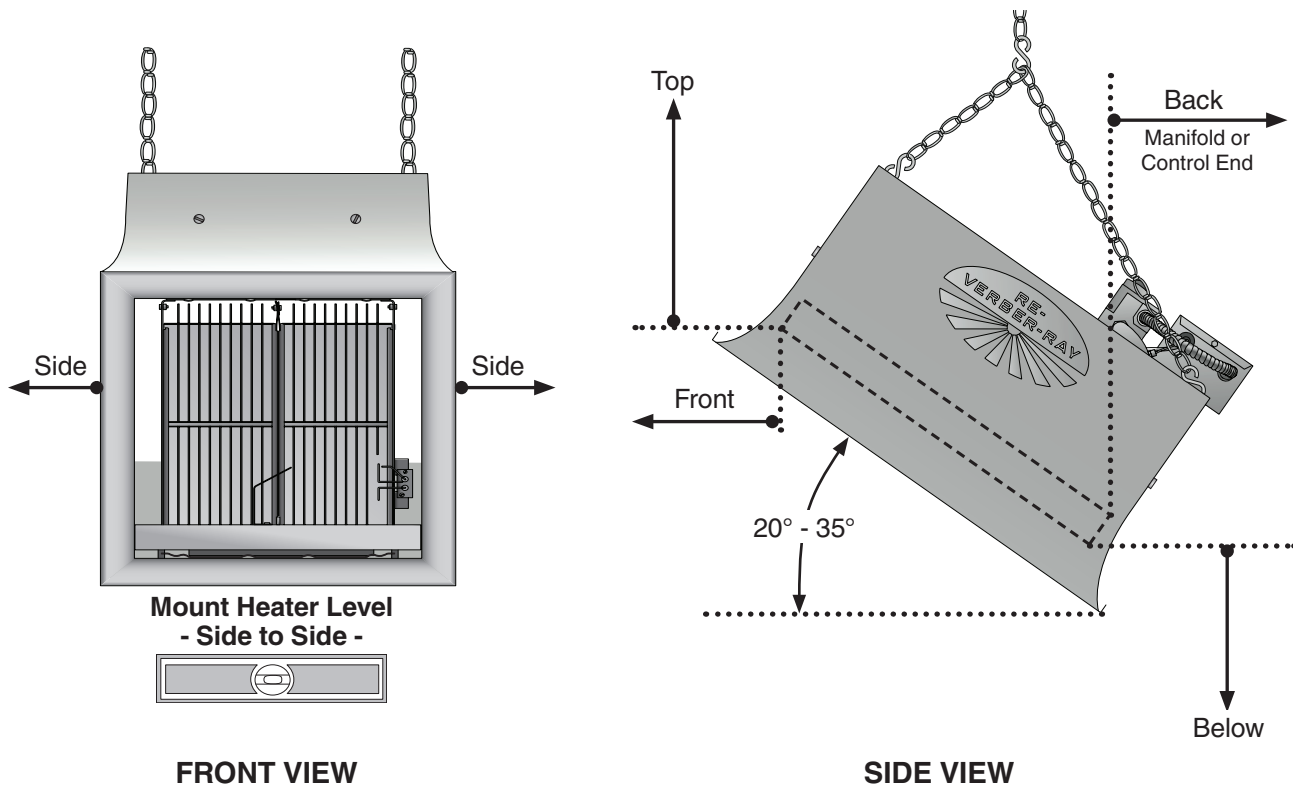

## Gas Connection

### ⚠ WARNING



An approved connector, suitable for the environment of equipment usage, is required. Visible or excessive swaying, flexing and vibration of the gas connections **must** be avoided to prevent failure. Neither the gas pipe nor the connector shall be placed in the 'flue discharge area'. In no case shall the gas supply support the weight of the heater.

To ensure your safety, and comply with the terms of the warranty, all units must be installed in accordance with these instructions.

## Standards, Certifications and Government Regulations

Installation of this infra-red heater must comply with all applicable local, state and national specifications, regulations and building codes. Contact the local building inspector and/or fire marshall for guidance.

In the absence of local codes, the installation must conform to the latest edition of:

**United States:** National Fuel Gas Code, ANSI Z223.1 (NFPA 54).

**Canada:** CAN/CGA B149.1 and .2, Canadian Electrical Code C22.1

### Chart 1.2 • Standards and Code Installation Guidelines • Building Aspect

Building Aspect	Codes and Guidelines
<b>Electrical</b>	<p>The heater must be electrically grounded in accordance with the following codes:</p> <p><b>United States:</b> Refer to National Electrical Code®, ANSI/NFPA 70 (latest edition). Wiring must conform to the latest edition of National Electrical Code®, local ordinances, and any special diagrams furnished.</p> <p><b>Canada:</b> Refer to Canadian Electrical Code CSA C22.1 Part 1 (latest edition).</p>
<b>Venting</b>	<p>The space being heated by unvented heaters must meet ventilation requirements.</p>

Chart 1.3 • Standards and Code Installation Guidelines • Building Type

Building Type	Codes and Guidelines
<b>Public Garages</b>	<p>Installation of this infra-red heater in public garages must conform to the following codes:</p> <p><b>United States:</b> Standard for Parking Structures NFPA 88A (latest edition) or the Code for Motor Fuel Dispensing Facilities and Repair Garages NFPA 30A (latest edition).</p> <p><b>Canada:</b> Refer to CAN/CGA B149.1 and B149.2: Installation Codes for Gas Burning Appliances.</p> <p>Guidelines:</p> <ul style="list-style-type: none"> <li>• Heaters must not be installed less than 8 ft. (2.4 m) above the floor. Minimum clearances to combustibles must be maintained from vehicles parked below the heater.</li> <li>• When installed over hoists, minimum clearances to combustibles must be maintained from the upper most point of objects on the hoist.</li> </ul>
<b>Aircraft Hangars</b>	<p>Installation of this infra-red heater in aircraft hangars must be in accordance with the following codes:</p> <p><b>United States:</b> Refer to Standard for Aircraft Hangars, ANSI/NFPA 409 (latest edition).</p> <p><b>In Canada:</b> Refer to Standard CAN/CGA B149.1 and B149.2.</p> <p>Guidelines:</p> <ul style="list-style-type: none"> <li>• In aircraft storage and servicing areas, heaters shall be installed at least 10 ft. (3 m) from above the upper surface of wings or of the engine enclosures of the highest aircraft that may be housed in the hangar. The measurement shall be made from the wing or engine enclosure, whichever is higher from the floor, to the bottom of the heater.</li> <li>• In areas adjoining the aircraft storage area (e.g., shops, offices) the bottom of heaters shall be installed no less than 8 ft. (2.4 m) above the floor.</li> <li>• Suspended or elevated heaters shall be located in spaces where they shall not be subject to damage by aircraft, cranes, movable scaffolding or other objects.</li> </ul> <p>Provisions shall be made to assure accessibility to suspended infra-red heaters for recurrent maintenance purposes.</p>

**Detroit Radiant Products units comply or are certified by one or more of the following organizations or standards:**

- CSA Design Certified (CSA 2.35).
- American National Standards (ANSI Z83.19).
- Occupational Safety and Health Act (OSHA).
- Underwriters Laboratory (UL).
- Certification of Europe (CE).
- Infrared Heater Safety Council. (IRSC).

# Safety Signs and Labels

It is important to provide warnings to alert individuals to potential hazards and safety actions. ANSI Z83.19 and the National Fuel Gas Code require you to post a sign “specifying the maximum permissible stacking height to maintain the required clearances from the heater to the combustibles” near the heaters thermostat or in absence of such thermostats in a conspicuous location. Signs should state the hazards for the particular application and be legible to the building occupants. Consult the factory or a factory representative for additional information on signage compliance.

Safety warning labels must be maintained on the infra-red heater. Illustrations of the safety labels, and their locations, are pictured below.

## Back Panel

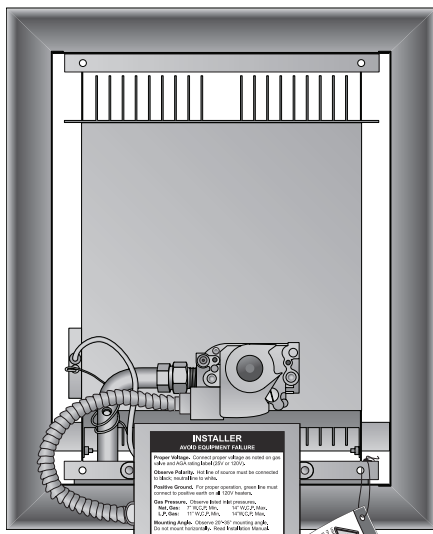

RE-VERBER-RAY RE-VERBER-RAY INFRA-RED RADIANT TUBE HEATER			
FOR OUTDOOR USE AND INDOOR (Non-Residential) INSTALLATION ONLY. High Intensity Infrared Heater Class IIIA Permanent Label			
MODEL NO. DR60-NFS-2 120	INPUT BTU/H 60,000	VERSION 05/97	FOR USE WITH Natural Gas
Volts AC: 120V - 60Hz	Manifold Pressure: 6.0 in. W.C.P.	Heater Type C1	
AMPS - Starting: 0.1	Maximum Inlet Pressure: 14 in. W.C.P.	Minimum Mounting Angle: 20 DEGREES	
AMPS - Running: 0.1	Minimum Inlet Pressure: 7.0 in. W.C.P.	Maximum Mounting Angle: 35 DEGREES	
Heater Type: C1			
DESIGN COMPLIES WITH: ANSI Z83.20-2001-GAS FIRED LOW INTENSITY INFRA-RED HTR.		Serial No. 08 07 DRPC 123456 0001	
DETROIT RADIANT PRODUCTS COMPANY 21400 HOOVER ROAD - WARREN, MI (586) 756-0950 - www.drp-co.com			

Rating Plate

## Bottom Panel

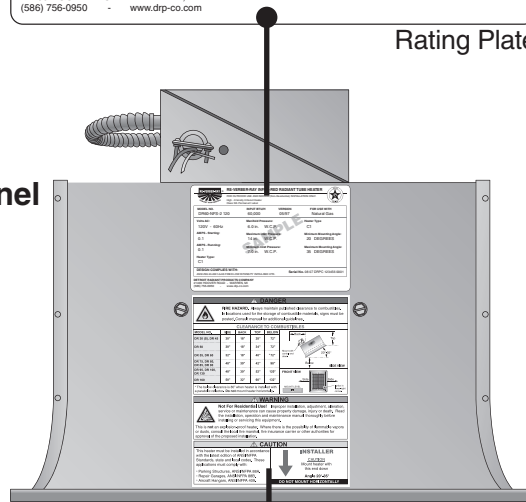

**⚠ DANGER**

**Avoid Serious Injury, Death or Property Damage.**  
Maintain Clearances to Combustible to Prevent the Risk of Fire.

Clearance to combustibles must be maintained at all times in order to prevent the ignition of combustible materials. In locations used for the storage of combustible materials, signs must be posted to specify the maximum permissible stacking height to maintain the required clearances from the heater to the combustibles. Signs must either be posted adjacent to the heater's thermostats or in the absence of such thermostats, in a conspicuous location. Clearances are provided on the heater's safety label and in the heater's Installation, Operation and Maintenance manual. Product installation and operation must comply with applicable standards, codes and regulations. Post this tag adjacent to the heater's thermostat or controls before operating the heater.

- INSTALLER: READ AND POST THIS NOTICE -

F/N: LL01 - Clearance Safety Tag  
(Affix adjacent to heater's thermostat)

**INSTALLER**  
**AVOID EQUIPMENT FAILURE**

**Proper Voltage.** Connect proper voltage as noted on gas valve and AGA rating label (25V or 120V).

**Observe Polarity.** Hot line of source must be connected to black; neutral line to white.

**Positive Ground.** For proper operation, green line must connect to positive earth on all 120V heaters.

**Gas Pressure.** Observe listed inlet pressures.  
**Nat. Gas:** 7" W.C.P. Min. 14" W.C.P. Max.  
**L.P. Gas:** 11" W.C.P. Min. 14" W.C.P. Max.

**Mounting Angle.** Observe 20°-35° mounting angle. Do not mount horizontally. Read Installation Manual.

**Wiring Diagram.** Found inside of this box.

LLDR002-10M-03/06 (M/WG)

F/N: LLD002

**⚠ DANGER**

**FIRE HAZARD.** Always maintain published clearance to combustibles. In locations used for the storage of combustible materials, signs must be posted. Consult manual for additional guidelines.

CLEARANCE TO COMBUSTIBLES				
MODEL NO.	SIDE	BACK	TOP	BELOW
DR 30 (S), DR 45	30"	18"	28"	72"
DR 50	30"	18"	34"	72"
DR 55, DR 60	32"	18"	40"	*72"
DR 75, DR 80, DR 85, DR 90	48"	30"	42"	98"
DR 95, DR 100, DR 130	48"	30"	52"	120"
DR 160	50"	32"	60"	132"

\* The below clearance is 80" when heater is installed with a parabolic reflector, Do not mount heater horizontally.

**⚠ WARNING**

**Not For Residential Use!** Improper installation, adjustment, alteration, service or maintenance can cause property damage, injury or death. Read the installation, operation and maintenance manual thoroughly before installing or servicing this equipment.

This is **not** an explosion-proof heater. Where there is the possibility of flammable vapors or dusts, consult the local fire marshal, fire insurance carrier or other authorities for approval of the proposed installation.

**⚠ CAUTION**

This heater must be installed in accordance with the latest edition of ANSI/NFPA Standards, state and local codes. These applications must comply with:

- Parking Structures, ANSI/NFPA 88A.
- Repair Garages, ANSI/NFPA 88B.
- Aircraft Hangars, ANSI/NFPA 409.

**INSTALLER**  
CAUTION  
Mount heater with this end down  
Angle 20°-35°  
**DO NOT MOUNT HORIZONTALLY**

Form # LLDCL002-04-06 (M/WG)

F/N: LLDCL002

Clearance to Combustibles Label



## 2.0 Installation

### ⚠ WARNING



Read and understand, the installation, operating and maintenance instructions thoroughly before installing or servicing this equipment.

Only trained, qualified gas installation and service personnel may install or service this equipment.

### ⚠ CAUTION

This heater cannot be used in a building with an uninsulated roof or condensation problems can occur.

### Design

To ensure a safe, properly designed heating system, a layout should be developed for the correct placement of the infra-red heater(s). Aside from safety factors such as clearance to combustibles (see Chart 1.1 on page 5), you should take also into consideration the environment (e.g., cold/drafty, average, protected), heat coverage (sq. ft.) needed, heater centers, the distance behind a person or work station(s) and exhaust path. Also, the effective infra-red surface temperature of a person or object may be diminished with wind above 5 mph. Wind barrier(s) may be required. Most importantly, clearance to combustibles **must** always be maintained! Refer to hazards on page 4.

This installation manual, along with national, state, provincial and local codes, address these issues. It is critical that you read, understand and follow all guidelines and instructions. Always inspect and evaluate the mounting conditions, space for exhaust, gas supply and wiring.

Perimeter mounting of infra-red heaters provides the most effective distribution of heat. The recommended spacing between the heaters is shown in Chart 2.1. Add additional heaters in the center of the space when heaters are spaced further than the recommended distance (see Figure 2.1 ).

When heated, materials high in hydrocarbons (solvents, paint thinner, mineral spirits, formaldehydes, etc.) can evaporate. This may result in odors or fumes being emitted into the environment. To correct this problem, clean the area and/or introduce additional ventilation. Heaters installed and serviced in accordance with the installation manual do not emit foul odors into the environment.

**IMPORTANT:** Fire sprinkler heads must be located at an appropriate distance from the heater to avoid an inadvertent discharge. This distance may exceed the published clearance to combustibles. Certain applications may require the use of high temperature sprinkler heads or relocation of the heaters.

### ⚠ CAUTION

Fire sprinkler systems containing propylene glycol, antifreeze or other potentially flammable substances shall not be used in conjunction with this heater without careful consideration for and avoidance of inadvertent discharge hazards. For further information consult NFPA 13. Always observe applicable state and local codes.

**Chart 2.1 • Recommended Mounting Heights and Distances for “Total Area” Heating**

Model No.	Mounting Heights Dim. A		Distance Between Heaters Dim. B (ft.)	Distance Between Heater Rows Dim. C (ft.)	Distance Between Heater and Wall (ft.)
	30° Angle Standard Reflector (ft.)	30° Angle Parabolic Reflector (ft.)			
DR 30(S)	12-14	12-15	8-30	10-70	6
DR 45	12-14	16-19	14-40	14-80	10
DR 50	12-14	17-20	14-40	14-80	10
DR 55	13-15	18-21	14-43	14-90	10
DR 60	14-16	18-21	15-43	15-90	12
DR 75	15-17	19-22	16-50	20-100	12
DR 80	15-17	19-22	16-50	20-100	12
DR 85	16-18	21-25	16-55	20-110	12
DR 90	16-18	21-25	20-55	20-110	12
DR 100	17-20	23-27	20-60	20-120	12
DR 130	21-24	26-32	22-65	23-140	14
DR 160	24-28	29-35	25-70	25-160	14

Factory recommended mounting heights are listed as a guideline. If infra-red heaters are mounted too low or too high, they may result in discomfort or lack of heat. Detroit Radiant Products Company generally recommends observing the recommended mounting heights to optimize comfort conditions. However, certain applications such as spot heating, freeze protection, outdoor patio heating or very high ceilings may result in the heaters being mounted outside of the recommended mounting heights.

**Figure 2.1 • Total Area Heating Sample Layout**

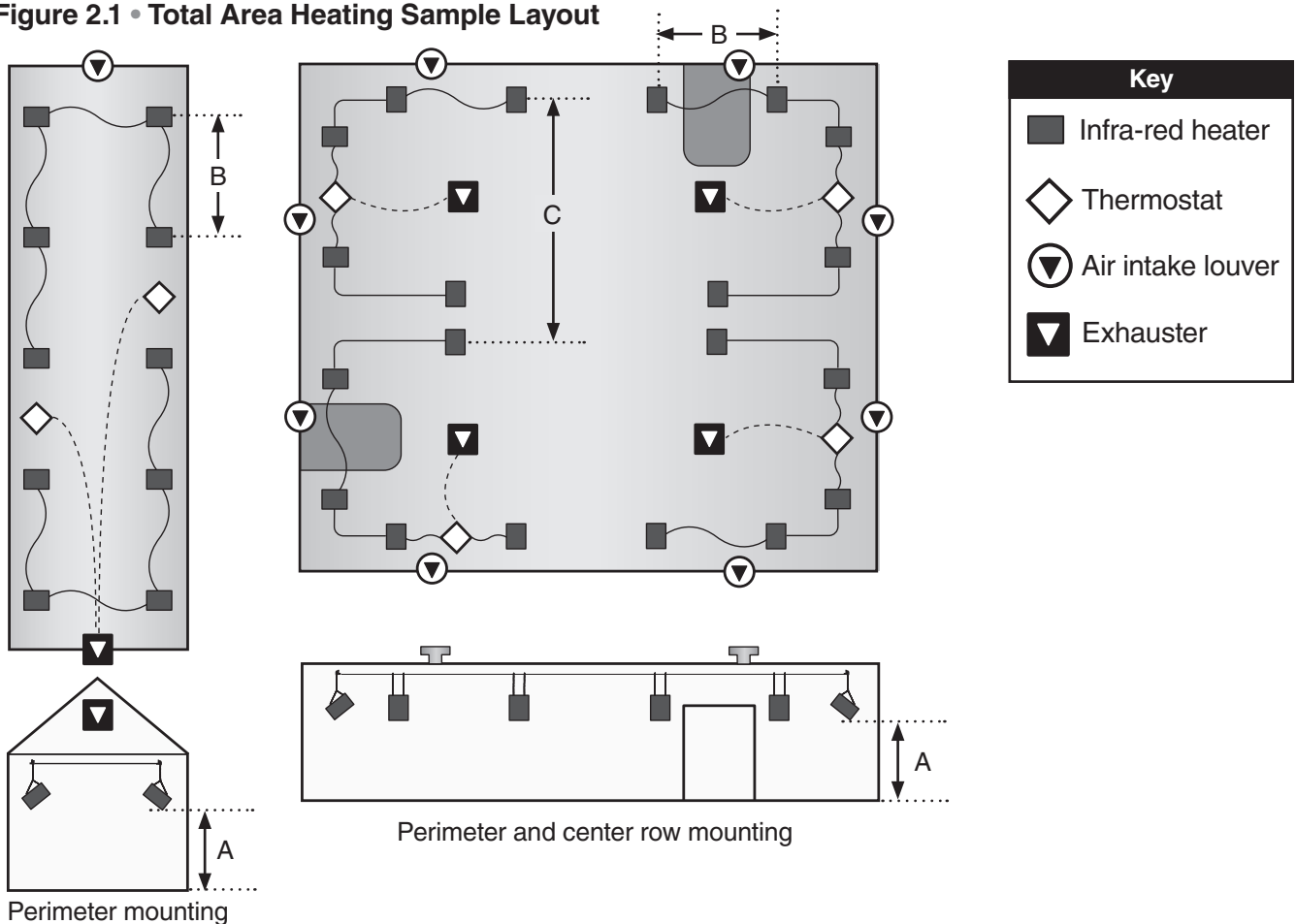
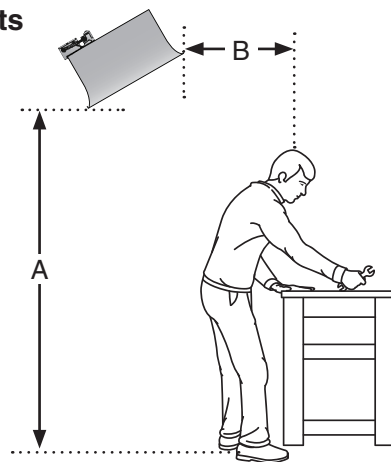

Chart 2.2 • Recommended Mounting Heights and Distances for “Spot” Heater Location

Model & Input	Type of Area (Surroundings)	Approx. Area Covered	Approx. Coverage (sq. ft.)	Recommended Mounting Height (Dim. A)											Distance Behind Person or Work Station (Dim. B)	Centers for Full Coverage (Spot & Area) Htg. Only	
				10'	12'	14'	16'	18'	20'	22'	24'	26'	28'	30'			
<b>DR-30</b> 30,000 BTU/H	Cold/Drafty	10' x 10'	100	9'												4'	10'
	Average	12' x 12'	144	10'	12'											5'	12'
	Protected/Insul.	14' x 14'	196		12'	14'										6'	14'
<b>DR-45</b> 45,000 BTU/H	Cold/Drafty	12' x 12'	144	10'	12'											5'	12'
	Average	14' x 14'	196		12'	14'										6'	14'
	Protected/Insul.	16' x 16'	256			14'	16'									7'	16'
<b>DR-60</b> 60,000 BTU/H	Cold/Drafty	16' x 16'	256		12'	14'										6'	16'
	Average	18' x 18'	324			14'	16'									7'	18'
	Protected/Insul.	20' x 20'	400				16'	18'								8'	20'
<b>DR-75</b> 75,000 BTU/H	Cold/Drafty	18' x 18'	324			14'	16'									7'	18'
	Average	22' x 22'	484				16'	18'								8'	22'
	Protected/Insul.	26' x 26'	676					18'	20'							9'	24'
<b>DR-90</b> 90,000 BTU/H	Cold/Drafty	20' x 20'	400				16'	18'								9'	20'
	Average	24' x 24'	576					18'	20'							10'	24'
	Protected/Insul.	28' x 28'	784						20'							11'	26'
<b>DR-100</b> 100,000 BTU/H	Cold/Drafty	24' x 24'	576					18'								10'	24'
	Average	28' x 28'	784					18'	20'							11'	26'
	Protected/Insul.	32' x 32'	1024						20'							12'	30'
<b>DR-130</b> 130,000 BTU/H	Cold/Drafty	26' x 26'	676					18'								11'	26'
	Average	30' x 30'	900					18'	20'							12'	28'
	Protected/Insul.	35' x 35'	1225						20'	22'						13'	32'
<b>DR-160</b> 160,000 BTU/H	Cold/Drafty	28' x 28'	784						20'	22'						12'	28'
	Average	35' x 35'	1225								24'	26'				16'	32'
	Protected/Insul.	40' x 40'	1600										28'	30'		20'	35'

Figure 2.2 • Spot Heater Heights



## Heater Mounting

### ⚠ WARNING



Improper suspension of the infra-red heater may result in collapse and being crushed. Always suspend from a permanent part of the building structure that can support the total force and weight of the heater.



Failure to maintain minimum clearance to combustibles may result in fire and/or explosion, property damage, serious injury or death. Always maintain minimum clearances and post signs or provided tags (F/N: LL01) where needed. Signs should state the hazards for the particular application and be legible to the building occupants. Consult the factory or a factory representative for additional information on signage compliance.

The heater can be suspended with chains or rigid threaded rod. Local codes, or conditions that would cause the unit to move (e.g., wind drafts, blowers, crane rails, etc.), may require rigid threaded rod. Consult all applicable codes before installation.

The heater must be level from side to side and between 20° and 35° from horizontal. The pilot burner or ignitor, manifold and controls must be located on the lower end. Refer to figures 2.3 and 2.4.

**Figure 2.3 • Heater Mounting**

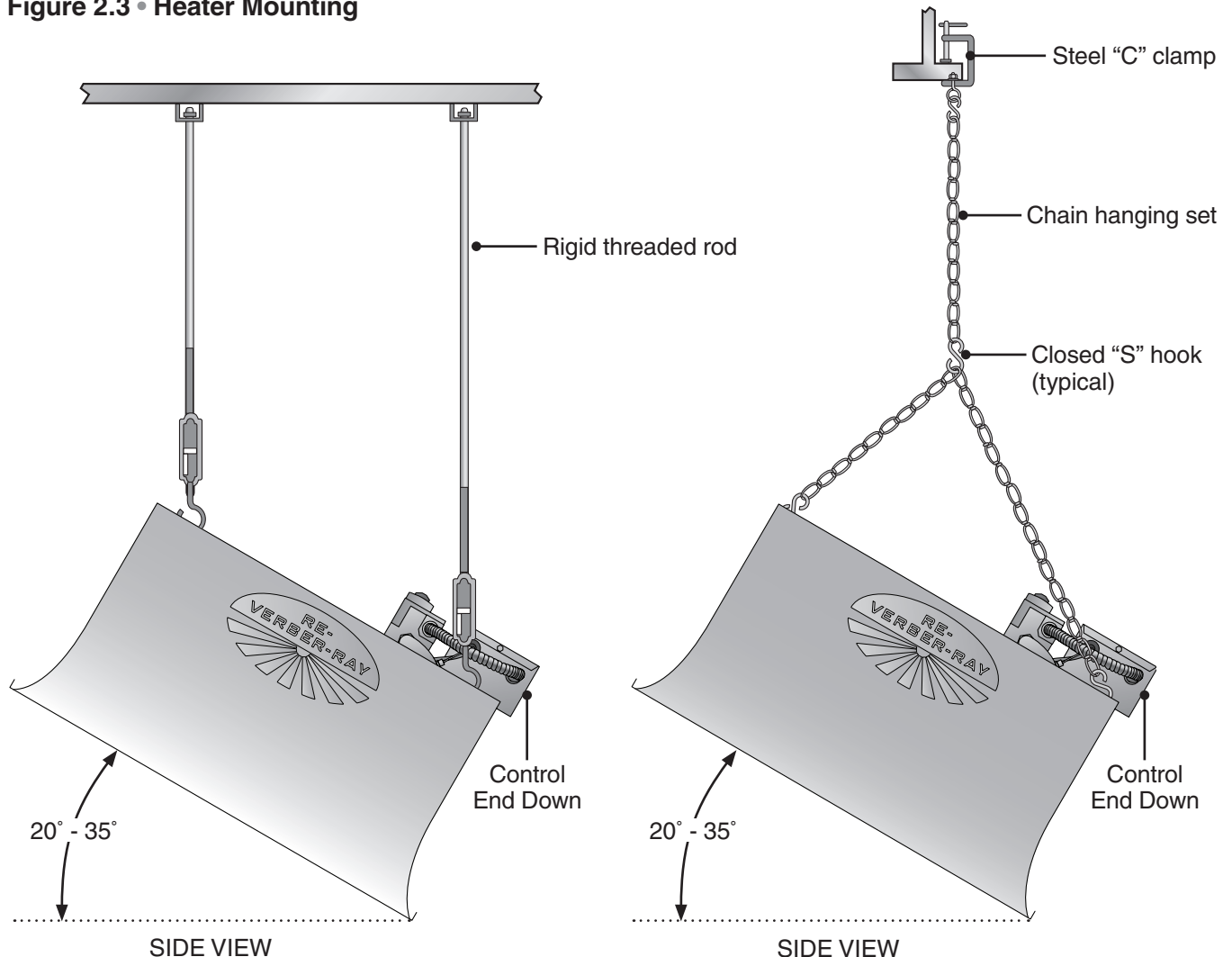

Figure 2.4 • Heater Orientation

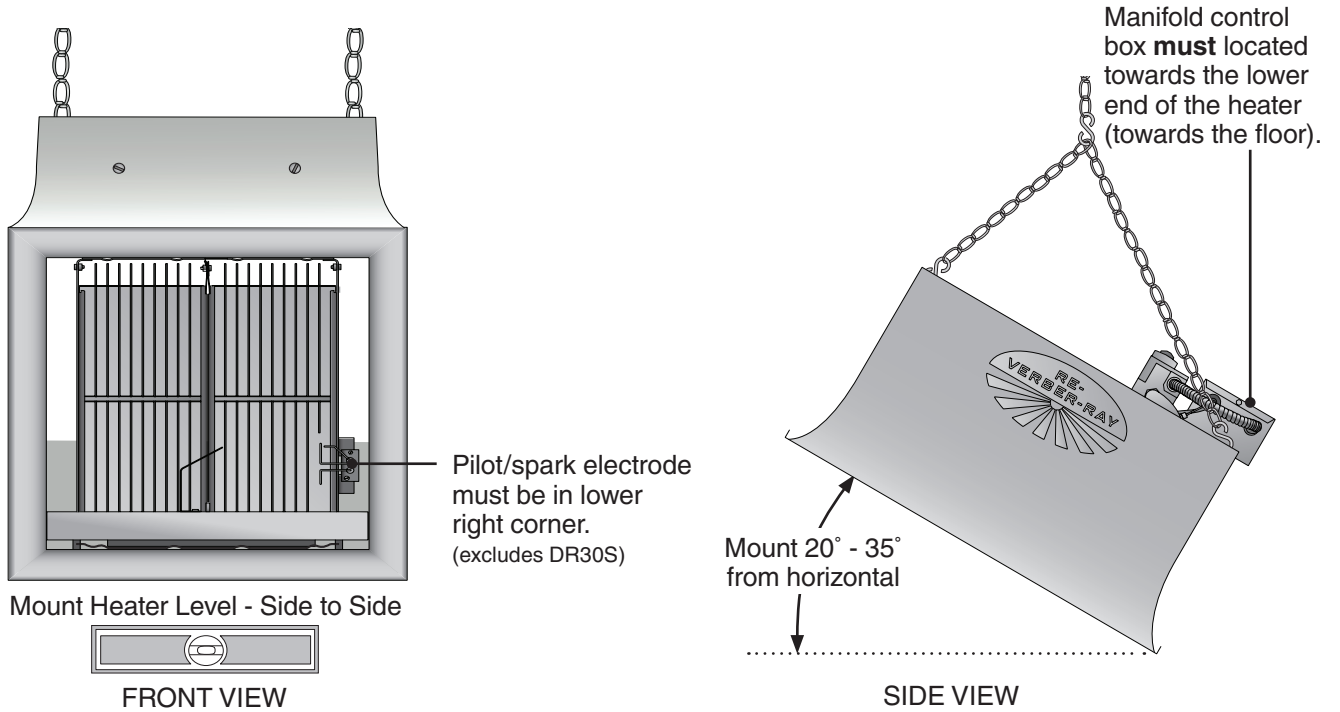
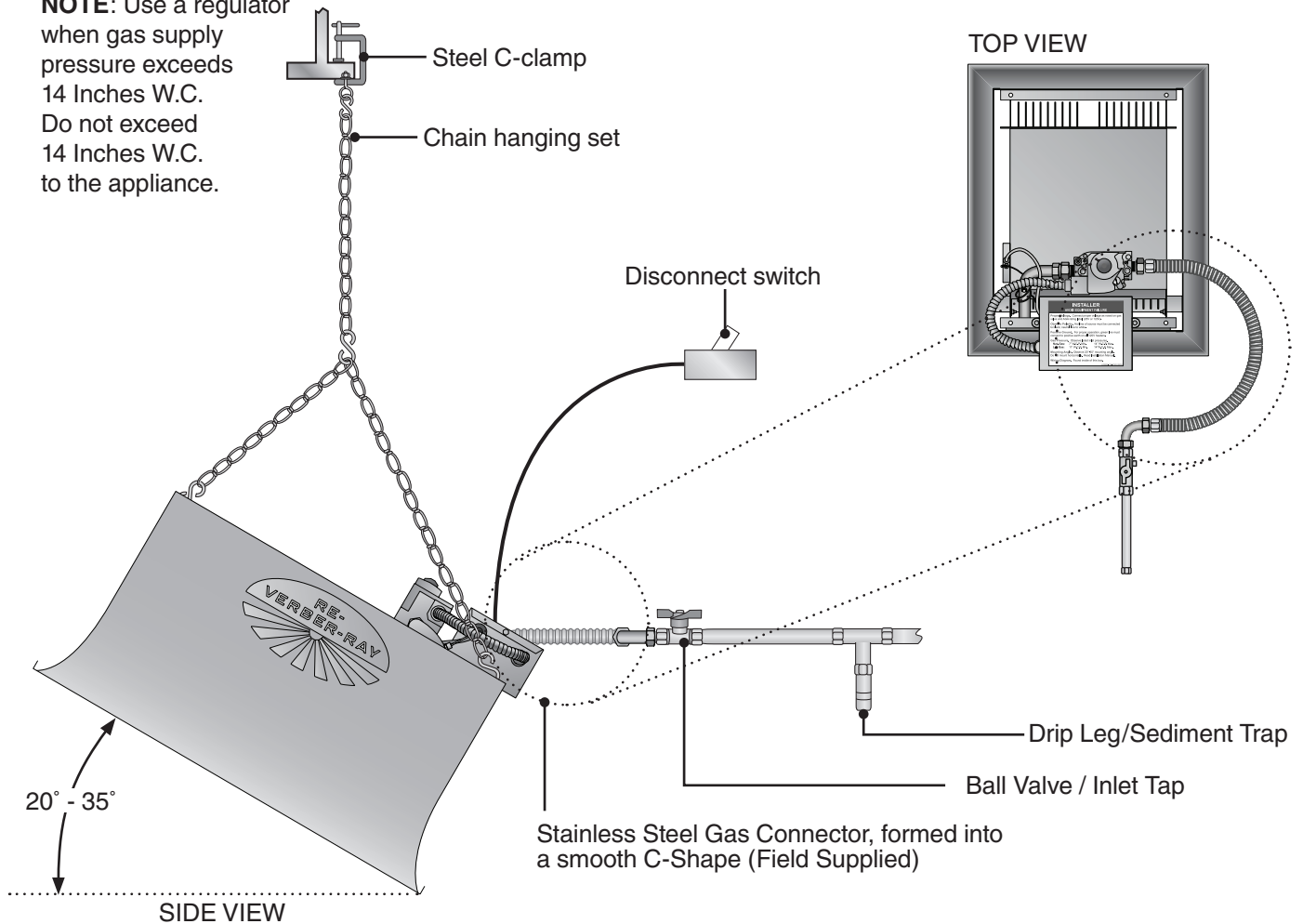

Figure 2.5 • Gas Connection

**NOTE:** Use a regulator when gas supply pressure exceeds 14 Inches W.C. Do not exceed 14 Inches W.C. to the appliance.



## Ventilation

### ⚠ WARNING



Insufficient ventilation may result in health problems, carbon monoxide poisoning or death. Vent enclosed spaces and buildings according to national, state, provincial and local codes.

Improper venting may result in asphyxiation, fire, explosion, injury or death.

It is required that the levels where heaters are mounted be properly ventilated to supply combustion air to the heaters and to sufficiently dilute the products of combustion. It is also required that the flue discharge area is kept clear of gas piping and electrical wiring (see Figure 2.6).

This infra-red heater must be vented in accordance with national, state, provincial and local codes and the guidelines in this manual. In the United States refer to the latest edition of ANSI Z223.1 (NFPA 54) and in Canada refer to the latest edition of the CAN/CGA B149.2 Standard.

**Figure 2.6 • Hot Flue Discharge**

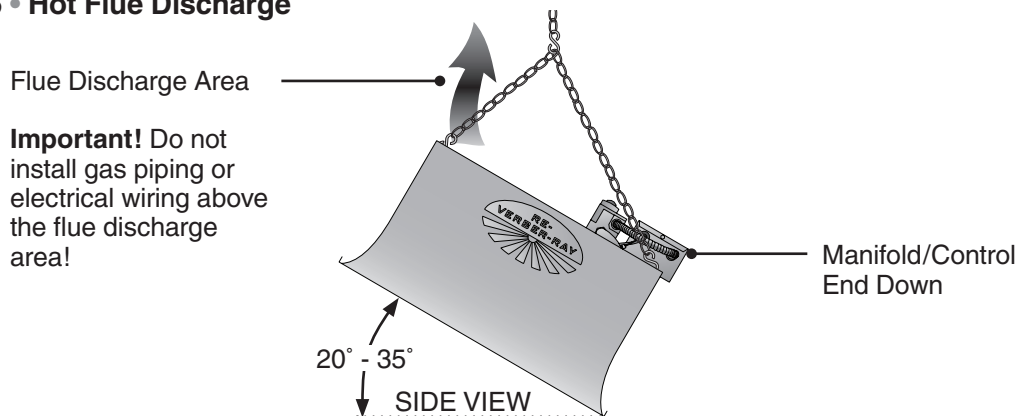

Provisions must also be made to provide sufficient fresh air intake area and exhaust air outlet area. For proper ventilation, a positive air displacement of 4 cfm/1000 Btu/h of gas consumed must be provided.

Where insufficient air movement exists, induced air displacement is required. A balanced system is essential to avoid negative building pressure which causes excessive infiltration, unfavorable drafts and affects combustion efficiency.

Air displacement may be accomplished by either natural or mechanical means. Mechanical exhausters are preferred and typically mounted at high points on the roof where stagnant air accumulates inside the building. For a flat roof, considerations of prevailing winds, high and low pressure areas, and distribution of air movement must be taken into consideration when locating exhausters.

Best air distribution is accomplished by using a number of small exhausters versus one large exhauster. Provide a minimum of one square inch of inlet area per 1000 BTU/H for combustion air supply. Inlet opening in the building should be well distributed (see Figure 2.1) high in the sidewalls and should direct incoming air upward to dilute products of combustion while preventing drafts at lower levels. Inlets are typically 1 to 3 sq. ft.

Local codes may require that mechanical exhaust systems be interlocked with heaters to enable both to function simultaneously (see page 17, Figure 2.7) or allow control of exhausters with a ceiling mounted humidistat.

## Gas Supply

### ⚠ WARNING



Improperly connected gas lines may result in fire, explosion, poisonous fumes, toxic gases, asphyxiation or death. Connect gas lines in accordance to national, state, provincial and local codes.

The gas supply to the infra-red heater must be connected and tested in accordance with national, state, provincial and local codes along with the guidelines in the Detroit Radiant DR Series manual. In the United States refer to the latest edition of the ANSI Z223.1 (NFPA 54) Standard and in Canada refer to the latest edition of the CAN/CGA B149.2 Standard.

**Important!** Before connecting the gas supply to the infra-red heater(s):

- Check that the gas piping and service has the capacity to handle the load of all heaters being installed, as well as any other gas appliances being connected to the supply line.
- Check that the main gas supply line is of proper diameter to supply the required fuel pressures.
- If utilizing used pipe, verify that its condition is clean and comparable to a new pipe. Test all gas supply lines in accordance with local codes.
- Test and confirm that inlet pressures are correct. Refer to the rating plate for required minimum and maximum pressures (see Chart 2.3). The gas supply pipe must be of sufficient size to provide the required capacity and inlet pressure to the heater (if necessary, consult the local gas company).

Chart 2.3 • Manifold Pressure

Type of Gas	Required Manifold Pressure	Minimum Inlet Pressure	Maximum Inlet Pressure
Natural	6.0 Inches W.C.	7.0 Inches W.C.	14.0 Inches W.C.
Liquefied Petroleum	10.0 Inches W.C.	11.0 Inches W.C.	14.0 Inches W.C.

**Note:** Check manifold pressure at the tap located either at the outlet of the gas valve or on the gas manifold pipe. Readings will be above atmospheric pressure during operation.

**Pressure Equivalents:** 1 inch W.C. equals .058 oz/sq. in. equals 2.49 Mbar.

To connect the gas:

### ⚠ WARNING



Failure to install, operate or service this appliance in the approved manner may result in property damage, injury or death.

This heater must be installed and serviced by trained gas installation and service personnel only.

The installation of this heater must conform with local building codes or, in the absence of such codes, the National Fuel Code (NFPA 54).



## ⚠ WARNING



An approved connector, suitable for the environment of equipment usage, is required. Visible or excessive swaying, flexing and vibration of the gas connections **must** be avoided to prevent failure. Neither the gas pipe nor the connector shall be placed in the 'flue discharge area'. In no case shall the gas supply support the weight of the heater.

The gas outlet must be in the same room as the appliance and accessible. It may not be concealed within or run through any wall, floor or partition.

- ① Install a sediment trap / drip leg if condensation may occur at any point of the gas supply line. This will decrease the possibility of loose scale or dirt in the supply line entering the heater's control system and causing a malfunction. Note: High pressure gas above 14 Inches W.C. (water column pressure) requires a high pressure regulator and ball valve (field supplied).
- ② Form the stainless steel flexible connector (field supplied) into a smooth C-shape allowing 12 in. between the flexible connector's end nuts. Figure 2.5 on page 13.
- ③ Attach the ball valve (field supplied) to the gas supply pipe. Apply pipe compound to NPT adapter threads to seal the joint. Use only a pipe compound resistant to liquid petroleum.  
**NOTE:** Provide a 1/8 in. NPT plugged tapping accessible for test gauge connection immediately upstream of gas connection to the heater (provided on ball valve, when supplied).

## ⚠ CAUTION

The fittings (nuts) on the flexible connector must be connected to an adapter. They may not be directly connected to the gas supply pipe.

- ④ Attach the flexible connector to the adapter and burner control box inlet. Seal the joints.  
**NOTE:** Excessive torque on the manifold may misalign the orifice. **Always** use two wrenches to tighten mating pipe connections.

## ⚠ WARNING



Testing for gas leaks with an open flame or other sources of ignition may lead to a fire or explosion and cause serious injury or death. Test in accordance with NFPA or local codes.

- ⑤ Final assembly must be tested for gas leaks according to NFPA or local codes.

## ⚠ CAUTION

In high moisture or corrosive environments, use gas supply lines and connectors suitable for the environment. Periodically inspect for signs of failure or leakage.



## Electrical

### ⚠ WARNING



#### Electric Shock

Field wiring to the heater must be connected and grounded in accordance with national, state, provincial, local codes and to the guidelines in this manual. In the United States refer to the most current revisions to the ANSI/NFPA 70 Standard and in Canada refer to the most current revisions the CSA C22.1 Part I Standard.

Control systems are initiated by either 120 VAC, 24 VAC or millivolt energy. The 120 VAC systems can be used directly from a 120 VAC line. On 24 VAC systems, transformers **must** be used to supply power of sufficient VA rating for single or multiple connected installations.

**Important!** Proper grounding and polarity are essential for heaters with spark ignition controls. If the system is not properly grounded, it cannot determine the presence of a flame and will lockout and shut off.

Millivolt systems require NO external power, as energy needed to operate the valve is developed by the power-pile generator. Do not use multiple connections, as one thermostat may only control one heater.

For wiring of controls on the unit see the wiring diagram included on page 18. It is recommended that the thermostat be installed on the hot side of a fused supply line and have a sufficient ampere capacity rating for the heater(s) it will control. The ventilation system may be controlled separately from the heating system (consult local codes) by the use of a humidistat that closes when the humidity rises. The humidistat control should be installed at roof level. For summer ventilation, a simple on/off switch can be installed at the occupant level.

**Figure 2.7 • Typical Field Wiring**

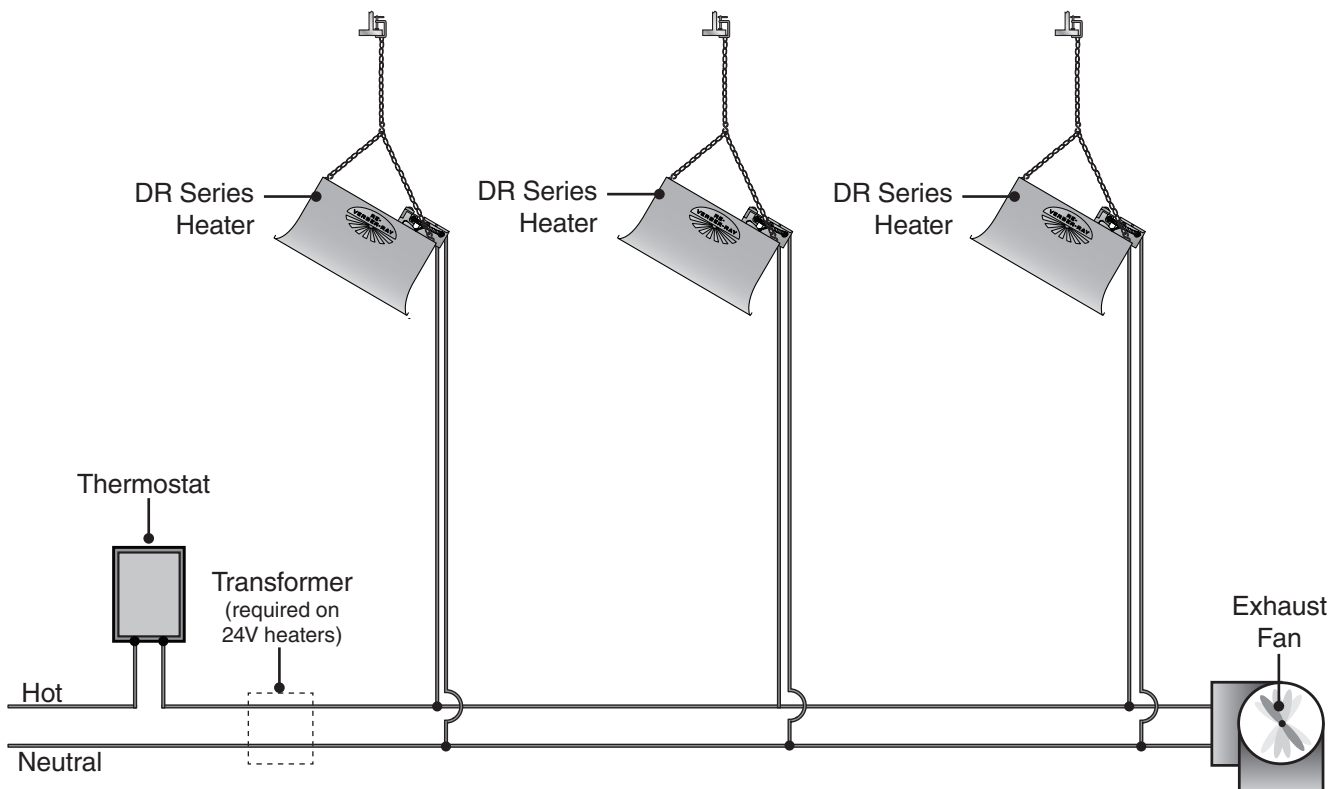

# Wiring Diagrams

**Figure 2.8 • NMV-2/PMV-2 • 750 Schematic**

- Millivolt Control

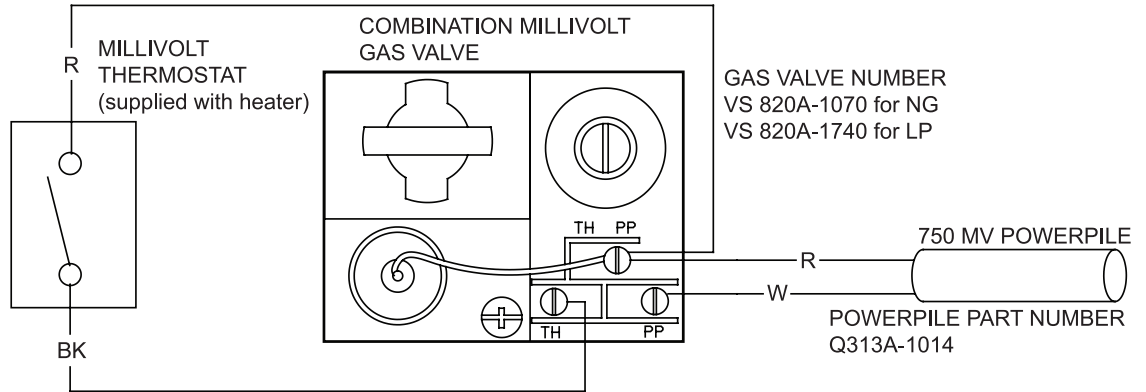

**Figure 2.9 • NFS-2/PFS-2 (24V) • 24 V Schematic**

- Direct Spark Ignition
- VA Draw: 12
- Amps: .48
- Potted Circuit Board

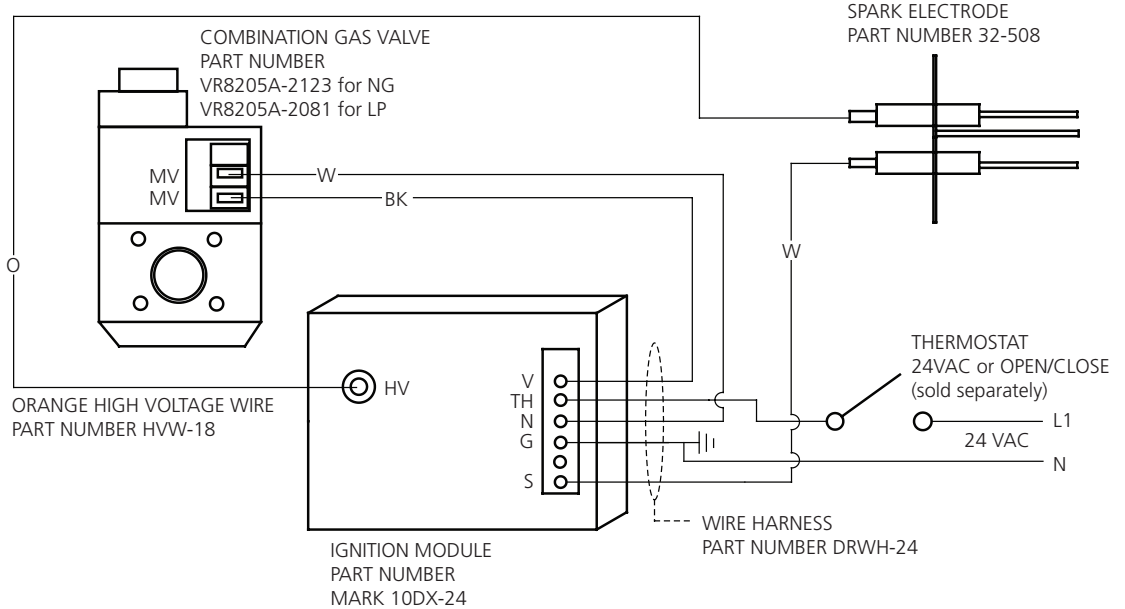

**Figure 2.10 • NFS-2/PFS-2 (120V) • 120 V Schematic**

- Direct Spark Ignition
- VA Draw: 12
- Amps: .10
- Potted Circuit Board

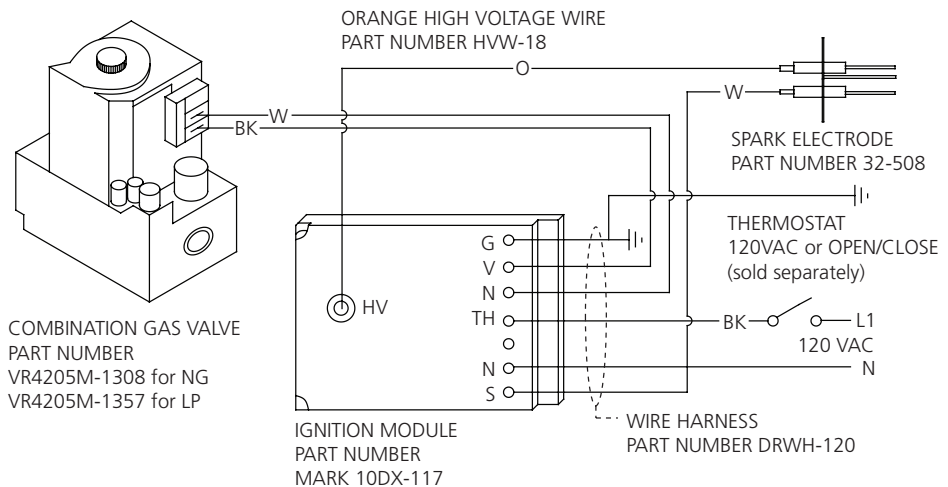

# 3.0 Operation

## ⚠ WARNING



Do not attempt to ignite a direct spark ignition heater by hand. Failure to comply could result in personal injury, property damage, explosion, fire or death.

Upon satisfactory completion of the electrical supply and purging of the gas supply line to the heater(s), follow the lighting instructions on the heater's rating label to put the heater into operation.

### **Direct Spark Ignition (NFS-2 / PFS-2)**

#### **Lighting Instructions**

- ① Rotate the heater's valve knob to the "ON" position.
- ② Close electrical circuit (typically the thermostat).
- ③ If the heater fails to light, turn off gas, open electrical circuit and wait 5 minutes before repeating the above steps.

#### **Shutdown Instructions**

- ① Open electrical circuit.
- ② Rotate the heater's valve knob to the "OFF" position.

#### **Sequence of Operation**

**Starting Circuit:** Upon a call for heat, voltage is applied to L1 and Neutral. After a pre-purge, the spark electrode is energized and the gas valve opens. The trial for ignition is 15 seconds. If flame is not sensed, the heater will attempt two more times to reignite.

**Running Circuit:** After ignition, the sensing electrode monitors the burner flame. If sense of flame is lost, the control immediately acts to reignite the gas-air mixture. If flame sense is not established within 15 seconds, the heater will attempt two additional ignition sequences before proceeding to hard lockout. The control can be reset by briefly interrupting the power source.

### **Millivolt (NMV-2 / PMV-2)**

#### **Lighting Instructions**

- ① Purge main gas supply line.
- ② Slightly depress and rotate the heater's manual gas valve knob COUNTERCLOCKWISE from the "OFF" position to the "PILOT" position.
- ③ Fully depress the manual gas valve knob and light the pilot burner. Continue to depress for 30 seconds and then release.
- ④ Rotate the heater's valve knob to the "ON" position.
- ⑤ Close the control circuit. If the heater fails to light, turn off the gas, open control circuit and wait 5 minutes before repeating the above steps.

#### **Shutdown Instructions**

- ① Open the control circuit.
- ② Rotate the heater's valve knob to the "PILOT" position, depress slightly and rotate to the "OFF" position.

#### **Sequence of Operation**

**Starting Circuit:** After manually lighting the pilot (see lighting instructions), upon a call for heat, the main burner solenoid is energized. The gas valve opens and the pilot lights the main burner.

**Running Circuit:** After ignition, the powerpile monitors the pilot flame. If the pilot flame is lost, the powerpile cools and closes the valve within 180 seconds. See lighting instructions to relight the heater.

# 4.0 Maintenance

It is recommended that the following become a standard yearly procedure to obtain maximum operating efficiency and trouble free operation.

During long periods of non-usage, remove or cover heater with a polyethylene bag and shut off gas supply. If further service to the heater is desired, contact your representative or the factory.

## Main Burner

- ① Gently use an air hose to blow any accumulated dust and/or dirt off the heater. Air hose pressure **must not exceed 30 psig**.
- ② Gently pass the air hose over the entire exposed area of the ceramic. A distance of 2' to 4' from the unit is recommended. **NOTE:** Blowing out the gasket material will permanently damage the rayhead.
- ③ Gently place the air hose outlet into each venturi tube and allow the air to flow for approximately one minute.
- ④ See troubleshooting chart (page 21) if there are any signs of burner malfunction. Replace if necessary.

## Pilot Burner

- ① Remove pilot access door.
- ② Use an air hose and gently blow the pilot burner free of dust or debris.

## Gas Supply

- ① Periodically inspect the gas supply for signs of corrosion or failure. Replace if necessary.

### **WARNING**



Use protective glasses when cleaning the heater.



Disconnect power to heater before servicing.



Do not operate unit if repairs are necessary. Do not operate unit showing any signs of burner malfunction. Call a professional for assistance.

### **CAUTION**



**Avoid Equipment Failure.**

Do not blow out heating elements with high pressure air.

Chart 4.1 Troubleshooting Guide

Symptom	Code	Possible Cause	Corrective Action
Burning of gas-air mixture inside plenum (flashback).	A, B A, B A, B A, B A, B	<ul style="list-style-type: none"> <li>• Heater mounted at incorrect angle.</li> <li>• Excessive drafts.</li> <li>• Gas leaking or blocked orifice/venturi.</li> <li>• Separation of ceramic grids.</li> <li>• Ceramic grids cracked.</li> </ul>	<ul style="list-style-type: none"> <li>• Mounting angle 20°-35° from horizontal.</li> <li>• Relocate or shield from draft.</li> <li>• Do not operate. Check with leak detector solution.</li> <li>• Do not operate. Replace rayhead.</li> <li>• Do not operate. Replace rayhead.</li> </ul>
Delayed ignition.	A A, B A, B A, B A, B	<ul style="list-style-type: none"> <li>• Electrode out of specification.</li> <li>• Low gas pressure.</li> <li>• Partially blocked orifice.</li> <li>• Improper orifice size.</li> <li>• Incorrect gas.</li> </ul>	<ul style="list-style-type: none"> <li>• See Figure 4.3.</li> <li>• See Gas Supply section.</li> <li>• Clean or replace.</li> <li>• Consult dealer.</li> <li>• Do not operate. See nameplate. Correct immediately.</li> </ul>
Low ceramic surface temperature, excessive rollout or soot on rods.	A, B A, B A, B A, B  A, B  A, B A, B A, B	<ul style="list-style-type: none"> <li>• Dirty or plugged rayhead ceramics.</li> <li>• Partially blocked orifice.</li> <li>• Low inlet gas pressure.</li> <li>• Low manifold gas pressure.</li>   <li>• High manifold pressure.</li>   <li>• Foreign matter in venturi tube.</li> <li>• Gas supply piping too small.</li> <li>• Incorrect gas.</li> </ul>	<ul style="list-style-type: none"> <li>• See maintenance instructions.</li> <li>• Remove and clean.</li> <li>• See Gas Supply section.</li> <li>• Adjust main valve regulator for 6" W.C.P. natural gas, 10" W.C. P. propane.</li> <li>• Adjust main valve regulator for 6" W.C.P. natural gas, 10" W.C. P. propane.</li> <li>• See Maintenance Section.</li> <li>• Increase inlet pressure or replace.</li> <li>• Do not operate. See nameplate. Correct immediately.</li> </ul>
Control system overheating.	A, B A, B	<ul style="list-style-type: none"> <li>• Heater not mounted correctly.</li> <li>• Heater mounted too close to ceiling.</li> </ul>	<ul style="list-style-type: none"> <li>• Mounting angle 20°-35° from horizontal.</li> <li>• Observe clearance to combustibles safety chart located on heater reflector. Do not operate.</li> </ul>
Gas odor.	A, B  B	<ul style="list-style-type: none"> <li>• Loose pipe connection.</li>   <li>• Pilot not lit.</li> </ul>	<ul style="list-style-type: none"> <li>• Check all connections with leak-detector solution, tighten as necessary.</li> <li>• Cycle thermostat or manually light.</li> </ul>
Heater cycles repeatedly.	A, B A A, B A, B B	<ul style="list-style-type: none"> <li>• Heater located in drafty area.</li> <li>• Low gas pressure.</li> <li>• Thermostat located in drafty area.</li> <li>• Weak pilot flame.</li> <li>• Defective flame detector.</li> </ul>	<ul style="list-style-type: none"> <li>• Relocate or shield from draft.</li> <li>• See Gas Supply section for propane.</li> <li>• Replace thermostat.</li> <li>• Clean or adjust pilot.</li> <li>• Replace.</li> </ul>
Pilot on, no gas to main burner.	B	<ul style="list-style-type: none"> <li>• Weak pilot flame.</li> <li>• No electrical power to unit.</li>   <li>• Pilot sensor element not located in pilot flame.</li> <li>• Defective main valve solenoid.</li> <li>• Defective pilot generator or thermocouple.</li> <li>• Excessive thermostat wire length with millivolt system.</li> <li>• Manual valve off.</li> </ul>	<ul style="list-style-type: none"> <li>• Clean or adjust pilot.</li> <li>• Check thermostat, manual switch or circuit breaker.</li> <li>• Locate upper 3/4 of element in pilot flame.</li> <li>• Isolate. Ohm for resistance, replace if "0".</li> <li>• Replace.</li> <li>• Wire not to exceed length provided by factory.</li>   <li>• Turn to "ON" position.</li> </ul>
No spark; no ignition.	A A A A A  A A	<ul style="list-style-type: none"> <li>• Lack of 120V or 24V incoming voltage.</li> <li>• Open high voltage wire.</li> <li>• Improper electrode gap.</li> <li>• Loose or open wire connection.</li> <li>• Poor or no equipment ground.</li>   <li>• Unit in "safety lockout" mode.</li> <li>• Defective "gas lighter" control.</li> </ul>	<ul style="list-style-type: none"> <li>• Proper voltage needed or repair wire.</li> <li>• Isolate and ohm for resistance, replace if "0".</li> <li>• See Figure 4.3.</li> <li>• Check all wires, tighten or replace.</li> <li>• Trace ground wire for complete circuit back to equipment ground from control.</li> <li>• Interrupt power source, repeat trial for ignition.</li> <li>• Verify proper voltage. Replace.</li> </ul>
Heater lights, and "locks out" after approximately 10 seconds.	A  A A A	<ul style="list-style-type: none"> <li>• Poor or no equipment ground.</li>   <li>• Polarity is reversed.</li> <li>• Low gas pressure.</li> <li>• Electrode not sensing.</li> <li>• Heater mounted at incorrect angle.</li> </ul>	<ul style="list-style-type: none"> <li>• Check all connections, provide positive earth ground.</li> <li>• 120V to black, neutral to white.</li> <li>• See Gas Supply section.</li> <li>• Relocate or replace if defective.</li> <li>• Mounting angle 20°-35° from horizontal.</li> </ul>
Spark is present. No main gas operation. Unit "locks out".	A A A	<ul style="list-style-type: none"> <li>• Gas valve in "Off" position.</li> <li>• Defective main valve solenoid.</li> <li>• Defective "Gas lighter" control.</li> </ul>	<ul style="list-style-type: none"> <li>• Turn to "On" position.</li> <li>• Isolate and check for resistance. Replace if "0".</li> <li>• Verify proper voltage. Replace.</li> </ul>
Heater will not shut off.	A, B A, B A, B	<ul style="list-style-type: none"> <li>• Defective thermostat or wiring.</li> <li>• Gas valve stuck open.</li> <li>• High gas pressure.</li> </ul>	<ul style="list-style-type: none"> <li>• Replace or repair.</li> <li>• Replace.</li> <li>• See Gas Supply section.</li> </ul>

**Code:**    **A** - Direct Spark Ignition (NFS-2/PFS-2)    **B** - Standing Pilot (NMV-2/PMV-2)

## Heater Assembly Components

For complete information on DR Series replacement parts, visit the online replacement parts library at <http://www.reverberray.com/partscenter>. For discontinued models, consult the factory.

**Note:** Replacement burners are called “rayheads” with rod inserts (part no. DR-RH and DR-ROD). Ceramic grids are not sold separately, order DR-RH.

**Figure 4.1 • Heater Assembly Components (side view)**

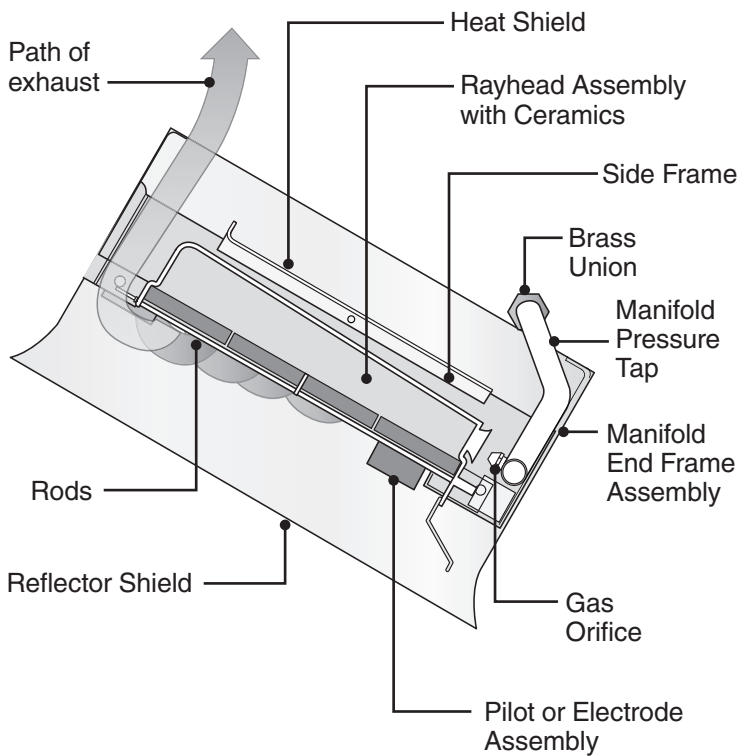

**Figure 4.2 • Heater Assembly Components (rear view of NFS-2/PFS-2)**

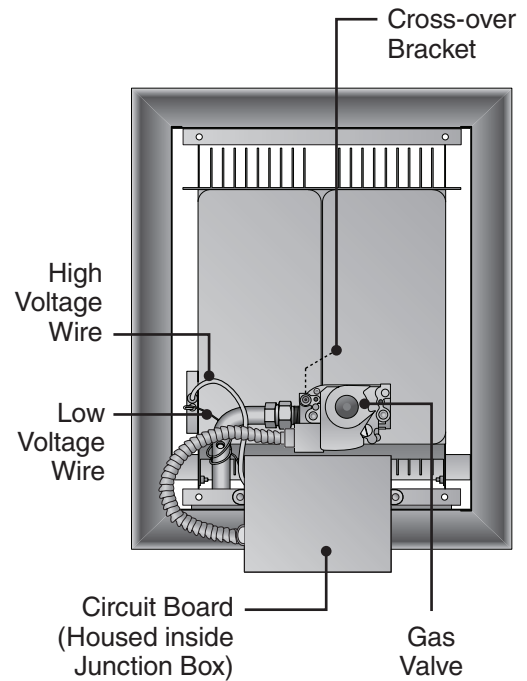

**Figure 4.3 • Spark Electrode Side View (NFS/PFS) Side View**

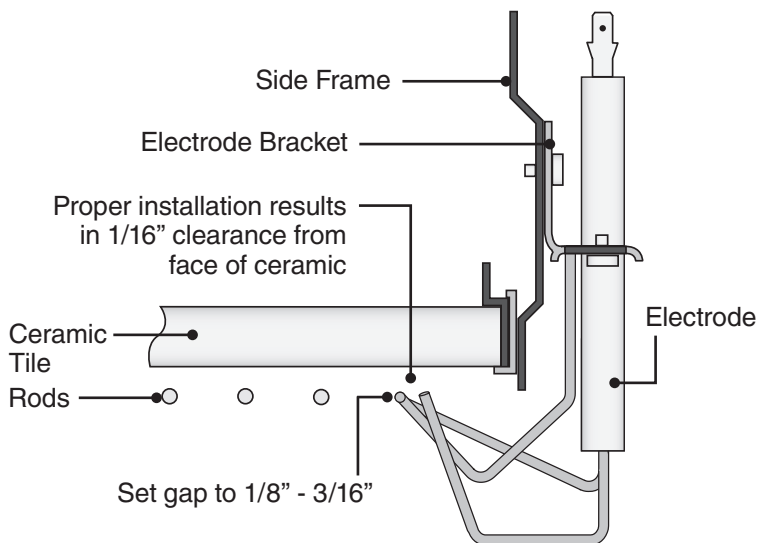

**Figure 4.4 • Pilot Assembly Side View (NMV/PMV)**

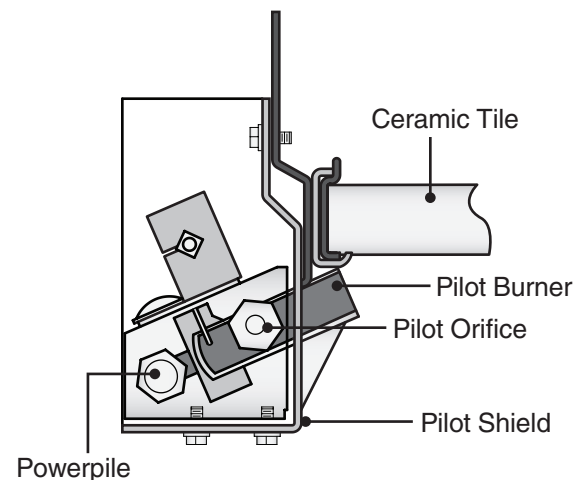

## Parts Listing

**IMPORTANT: Contact factory for conversion assistance. NOTE:** Gas type conversions require gas valve and gas orifice among other changes. Conversion may also require burner and crossover changes.

**Chart 4.2 • Direct Spark NFS-2/PFS-2 Control Components**

Part No.	Description	Voltage
VR8205A-2123	Combination gas valve, natural gas	25V
VR4205M-1308	Combination gas valve, natural gas	120V
VR8205A-2081	Combination gas valve, propane gas	25V
VR4205M-1357	Combination gas valve, propane gas	120V
32-508	Main burner electrode	25V, 120V
Mark-10DX-24	25V circuit board	25V
DRWH-24	Wiring harness for Mark-10DX-24 circuit board	25V
Mark-10DX-117	120V circuit board	120V
DRWH-120	Wiring harness for Mark-10DX-117 circuit board	120V
HVW-18	High voltage ignition wire	25V, 120V
LVW-18	Low voltage ignition wire	25V, 120V

**Chart 4.3 • Millivolt NMV-2/PMV-2 Control Components**

Part No.	Description
VS820A-1070	Combination gas valve, natural gas
VS820A-1740	Combination gas valve, propane gas
Q313-1014	Pilot flame detector powerpile
F10-1	Pilot burner
69-1818	Pilot orifice, natural gas
69-0764	Pilot orifice, propane gas
RV 12-6"	Pilot regulator, natural gas
RV 12-11"	Pilot regulator, propane gas

**Chart 4.4 • Miscellaneous Core Components**

Part No.	Description	Part No.	Description
DR-MAN#	Manifold	DR-FL31	3/8" conduit attachment fitting (NFS-2/PFS-2)
DR-UF#*	Upper frame (*specify 1-5)	DR-EMB	Electrode mounting bracket (NFS-2/PFS-2)
DR-HS#*	Heat shield (*specify 1-5)	DR-RSB	Red Rubber Spark Boot (NFS-2/PFS-2)
DR-FLSH#*	Flash shield (*specify 1-5)	DR-LVG	Low volt black wire grommet (NFS-2/PFS-2)
DR-RFE#	Reflector End (*specify 1-5)	DR-HVG	High volt black wire heyco grommet (NFS-2/PFS-2)
DR-#REF*	Full Reflector Assembly (*specify 1-5)	JB-0514	JB-0514 junction box (NFS-2/PFS-2)
DR-SF	Side frame	DR-8SMS	#8 x 1/2" common sheet metal screw
DR-SFI	Side frame insert	DR-20MB	1/4 - 20 x 1/2" machine screw (DR Bolt)
DR-ERS	Embossed reflector sides	DR-20HN	1/4 - 20 hex nut (mates to DR bolt)
DR-RH	Rayhead with center support	DR-20STB	1/4 - 20 x 1/2" self-tap DR bolt
DR-RHP	Rayhead no center support (DR 30-45 LP models only)	DR10-EMS	1/4 - 10 short electrode mounting screw
DR-CO	Cross-over bracket	DR-8STS	#8 x 1/2" sheet metal self-tap screw
DR-LROD	Long rayhead rod	DR-DOOR	Pilot access door with zip screw (NMV-2/PMV-2)
DR-SROD	Short rayhead rod	DR-MU	Union fitting, 3-piece
DR-MU	3-piece brass union	F10-PS	Pilot shield for F10-1 pilot burner (NMV-2/PMV-2)
ORF-#	Brass gas orifice (specify model #)	PL-1	Pilot line for DR 30 (NMV-2/PMV-2)
DR-FC	3/8" flex conduit (NFS-2/PFS-2)	PL-2	Pilot line for DR 45-DR 160 (NMV-2/PMV-2)

\*Reference proper part number when ordering these parts: 1=DR30; 2=DR45-60; 3=DR75-100; 4=DR 130, 5=DR 160  
Visit our online parts reference library at [www.reverberray.com](http://www.reverberray.com) for further part related technical data.



## 5.0 Limited Warranty

---

**One-Year Limited Warranty.** Detroit Radiant Products Company (hereinafter referred to as the Company) warrants to the original purchaser or original user that all Detroit Radiant Gas Infra-Red Heaters sold by it and all parts thereof are free from defects in material or workmanship under normal use and service. The Company's sole obligation under this warranty shall be limited to furnishing replacement parts, F.O.B. Warren, Michigan, for 12 months from the date of initial installation of the heater, but not to exceed 18 months from the date of shipment by the Company of the heaters, for any parts which the Company's examination shall disclose to its satisfaction to be defective. Defective parts are to be returned to the Company, transportation charges prepaid.

**Four-Year Additional Limited Warranty for CSA or UL Approved Models.** In addition to the above-mentioned First-Year Warranty, the Company warrants to the original purchaser or original user of CSA or UL Listed Gas Infra-Red Heaters that it will at any time during the four years following the expiration date of the First-Year Warranty, furnish ceramic rayhead burners exclusive of controls, F.O.B. Warren, MI 48089, for any ceramic rayhead burners which are proved to the satisfaction of the Company to be inoperative due to defects in material or factory workmanship. The Company's sole obligation under this warranty shall be limited to furnishing ceramic rayhead burners.

This four-year additional warranty covers the ceramic rayhead burners only.

**General Conditions.** The warranties set out in this certificate are the exclusive remedy of the original owner or user in lieu of all other warranties written, oral or implied (including any warranty of merchantability or fitness for the purpose) and all other obligations or liabilities on the part of the Company, and the Company neither assumes nor authorizes any person to assume for it any other obligation or liabilities on the part of the Company, and the Company neither assumes nor authorizes any person to assume for it any other obligation or liability in connection with the sale, installation or use of the heater or any parts thereof.

The Company will not be responsible for labor charges for the analysis of a defective condition in the heater or for the installation of replacement parts. The warranties provided herein will not apply if the input of the heater exceeds the rated input at time of manufacturing or if the heater in the judgment of the Company has been subjected to misuse, excessive dust, improper conversion, negligence, accident, corrosive atmospheres, excessive thermal shock, excessive vibration, physical damage to the heater, alterations by unauthorized service personnel, operation contrary to the Company's instructions or if the serial number has been altered, defaced, or removed. The Company shall not be liable for any default or delay in the performance of these warranties caused by contingency beyond its control, including war, government restriction or restraints, strikes, fire, flood, short or reduced supply of raw materials, or parts.

The warranties herein shall be null and void if the heater is not installed by a competent heating contractor and/or if the heater is not installed according to Company instructions, normal industry practices and/or if the heater is not maintained and repaired according to Company's instructions. Normal product degradation and wear (rust, oxidation, etc.) does not constitute a material defect and applicable warranty claim.

Written permission is required for the return of any parts or equipment and any such return must be made on the basis of transportation charges prepaid. Shipment may be refused unless prior written permission is obtained and goods returned prepaid.

This Warranty applies only within the United States.

**© 2009 Detroit Radiant Products Company**

21400 Hoover Road Warren, MI 48089 U.S.A.

Voice: (586) 756-0950

Fax: (586) 756-2626

Website: [www.detroitradiant.com](http://www.detroitradiant.com)