

# Rinnai®

## Direct Vent Service Manual

RHFE-551FA

RHFE-1001FA

RHFE-1001FA/VA

RHFE-201FA

RHFE-263FA, FAII

RHFE-431FA, FAII, FAIII, WTA

RHFE-556FA, FAII, FAIII, FTRA, FTRAI, WTA

RHFE-1004FA

ES08 RHFE-201RFA

ES11 RHFE-263RFA

ES17 RHFE-433RFA

EX17 RHFE-433RWTA

ES22 RHFE-558RFA

EX22 RHFE-558RWTA

ES38 RHFE-1004RFA, RHFE-1004FTA

EX08C RHFE-202FTA

EX11C RHFE-265FTA

EX17C RHFE-434FTA

EX22C RHFE-559FTA

# Table of Contents

General Information.....	3	Fault Finding Charts .....	64
Specifications .....	4	Wiring Diagram (1001FA/VA).....	68
Sequence of Operations.....	6	Lockout Check List .....	69
<b>Fault Isolation</b>		<b>1004FA, 1004RFA, 1004FTA</b>	
Accessing Fault Codes.....	7	Troubleshooting Information .....	71
Fault Isolation Codes.....	9	Wiring Diagram.....	73
Fault Isolation - Other Issues .....	11	Ladder Diagram .....	74
		Lockout Check List.....	75
<b>201FA, 201RFA</b>		Extension Installation Requirements .....	76
Troubleshooting .....	12	Vent Kits and Extension Sets .....	78
Wiring Diagram .....	14	Vent Extension Covers .....	79
Ladder Diagram .....	15	Installations at Altitude.....	79
<b>263FA, 263FAII, 263RFA</b>		Gas Pressure Setting Procedure	
Troubleshooting .....	16	201FA, 263FA, 263FAII .....	80
Wiring Diagram .....	18	201RFA, 263RFA .....	82
Ladder Diagram .....	19	202FTA, 265FTA.....	85
<b>202FTA, 265FTA</b>		431FA/WTA, 556FA/WTA .....	87
Troubleshooting .....	20	433RFA, 558RFA.....	89
Wiring Diagram .....	21	433RWTA, 558RWTA .....	92
Ladder Diagram .....	22	434FTA, 559FTA.....	95
<b>431FA Series, 556FA/FTRA Series</b>		1004FA.....	97
Troubleshooting .....	23	1004RFA, 1004FTA .....	98
Wiring Diagrams		Dip Switch Settings.....	101
431FA Series, 556FA/FTRA.....	26	Checking Micro-Amps	
556FAIII .....	27	(431, 556, 201, 263) .....	102
556FTRAIII.....	28	Setting up the U Tube Manometer	
<b>431WTA, 556WTA</b>		(431, 556, 201, 263) .....	103
Troubleshooting .....	29	Thermistor.....	104
Wiring Diagrams (431WTA).....	32	Flame Rectification .....	104
Wiring Diagrams (556WTA).....	33	Setting a Maximum Temperature .....	105
<b>433RFA, 558RFA</b>		Harmonic Noise (1004FA).....	105
Troubleshooting .....	34	Removal of "OF" on New PC Board	
Wiring Diagram .....	35	Installation.....	106
Ladder Diagram .....	36	Wire Diagram Abbreviations.....	110
<b>433RWTA, 558RWTA</b>		Serial Number Format .....	111
Troubleshooting .....	37		
Wiring Diagram .....	38		
Ladder Diagram .....	39		
<b>434FTA, 559FTA</b>			
Troubleshooting .....	40		
Wiring Diagram .....	41		
Ladder Diagram .....	42		
<b>551FA, 1001FA, 1001FA/VA</b>			
Troubleshooting (551FA) .....	43		
Fault Finding Charts.....	45		
Wiring Diagram (551FA) .....	55		
Troubleshooting (1001FA) .....	56		
Fault Finding Charts.....	58		
Wiring Diagram (1001FA) .....	61		
Troubleshooting (1001FA/VA) .....	62		

## General Information

### Safety Definitions



This is the safety alert symbol. This symbol alerts you to potential hazards that can kill or hurt you and others.



Indicates an imminently hazardous situation which, if not avoided, will result in death or serious injury.



Indicates a potentially hazardous situation which, if not avoided, could result in death or serious injury.



Indicates a potentially hazardous situation which, if not avoided, could result in minor or moderate injury. It may also be used to alert against unsafe practices.

### Using this Manual

Repairs should be performed by a qualified service technician.

The following information can be referenced for additional information.

- Operation and Installation Manual
- Conversion Manual
- Technical Bulletins

### Technical Support

Technicians are available to assist in servicing issues. Contact Rinnai Technical Services at 1-800-621-9419.

### Recommended Tools

- Volt/Ohm/Amp meter with test probes
- U tube type manometer with 14 inch water column (W.C.) scale, two hoses and two 1/8 inch taps
- assorted wrenches including a 3/16 Allen wrench
- assorted screw drivers
- leak solution or leak detector



There are a number of live tests that are required when fault finding this product. Extreme care should be used at all times to avoid contact with energized components inside the furnace. Before checking for resistance readings disconnect the power source to the unit and isolate the item from the circuit (unplug it).



Label all wires prior to disconnection when servicing controls. Wiring errors can cause improper and dangerous operation.

If any of the original wire as supplied with the appliance must be replaced, it must be replaced with type 18 AWG wire or its equivalent.

# Specifications

	201FA	263FA, FAII	202FTA (EX08C)	265FTA (EX11C)	1004FA 1004RFA (ES38) 1004FTA (ES38)	551FA	1001FA 1001FA/VA
<b>BTU Input NG</b>	3,000-8,000	5,500-11,000	3,000-8,000	5,500-11,000	10,500-38,400	22,000 (max)	38,400 (max)
<b>BTU Input LP</b>	3,000-8,000	5,700-11,000	3,000-8,000	5,700-11,000	10,500-36,500	21,000 (max)	36,500 (max)
<b>AFUE Rating NG</b>	80.6%	80%	81%	80%	80.6%	NA	NA
<b>AFUE Rating LP</b>	83.4%	80%	82%	81%	82%	NA	NA
<b>Gas Supply Pressure (NG)</b>	4.5-10.5 in (114-267 mm) W.C.	3.5-10.5 in (89-267 mm) W.C.	4.5-10.5 in (114-267 mm) W.C.	3.5-10.5 in (89-267 mm) W.C.	5.0-10.5 in (127-267 mm) W.C.	4.5-10.5 in (114-267 mm) W.C.	5.0-10.5 in (127-267 mm) W.C.
<b>Gas Supply Pressure (LP)</b>	8-13 in (203-330 mm) W.C.	8-13 in (203-330 mm) W.C.	8-13 in (203-330 mm) W.C.	8-13 in (203-330 mm) W.C.	11-13 in (279-330 mm) W.C.	11-13 in (279-330 mm) W.C.	11-13 in (279-330 mm) W.C.
<b>Electrical Connection (at high fire)</b>	AC 120V, 60 Hz, 42 watts	AC 120V, 60 Hz, 47 watts	AC 120V, 60 Hz, 41 watts	AC 120V, 60 Hz, 44 watts	AC 120V, 60 Hz, 121 watts	AC 120V, 60 Hz, 120 watts	AC 120V, 60 Hz, 120 watts
<b>Sound Level</b>	27-34 dB(A)	31-38 dB(A)	27-36 dB	31-38 dB	37-47 dB(A)	35-44 dB(A)	35-46 dB(A)
<b>Fan CFM</b>	48.3-78.6	96.4-128.5	48.3- 78.6	96.4-128.5	203.4-360.6	135-189	179-289
<b>Weight</b>	39.4 lbs (17.9 kg)	37 lbs (17 kg)	46 lbs (21 kg)	46 lbs (21 kg)	90 lbs (41 kg)	74 (34 kg)	110 (50 kg)

## Specifications

	431FA Series, WTA	556FA/FTRA Series, WTA	433RFA (ES17)	558RFA (ES22)	433RWTA (EX17)	558RWTA (EX22)	434FTA (EX17C)	559FTA (EX22C)
<b>BTU Input NG</b>	8,200-16,700	8,200-21,500	8,200-16,700	8,200-21,500	8,200-16,700	8,200-21,500	8,200-16,700	8,200-21,500
<b>BTU Input LP</b>	8,200-16,700	8,200-20,700	8,200-16,700	8,200-20,700	8,200-16,700	8,200-20,700	8,200-16,700	8,200-20,700
<b>AFUE Rating NG</b>	80.8%	80.6%	81%	81%	81%	80.6%	81%	80%
<b>AFUE Rating LP</b>	81%	81%	80%	80%	81%	81%	82%	82%
<b>Gas Supply Pressure (NG)</b>	3.5-10.5 in (89-267 mm) W.C.	5.0-10.5 in (127-267 mm) W.C.	3.5-10.5 in (89-267 mm) W.C.	3.5-10.5 in (89-267 mm) W.C.	3.5-10.5 in (89-267 mm) W.C.	3.5-10.5 in (89-267 mm) W.C.	3.5-10.5 in (89-267 mm) W.C.	3.5-10.5 in (89-267 mm) W.C.
<b>Gas Supply Pressure (LP)</b>	8-13 in (203-330 mm) W.C.	8-13 in (203-330 mm) W.C.	8-13 in (203-330 mm) W.C.	8-13 in (203-330 mm) W.C.	8-13 in (203-330 mm) W.C.	8-13 in (203-330 mm) W.C.	8-13 in (203-330 mm) W.C.	8-13 in (203-330 mm) W.C.
<b>Electrical Connection (at high fire)</b>	AC 120V, 60 Hz*, 40 watts	AC 120V, 60 Hz*, 55 watts	AC 120V, 60 Hz*, 45 watts	AC 120V, 60 Hz, 50 watts	AC 120V, 60 Hz, 47 watts	AC 120V, 60 Hz, 47 watts	AC 120V, 60 Hz, 46 watts	AC 120V, 60 Hz, 46 watts
<b>Sound Level</b>	32-38 dB(A)	32-41 dB(A)	32-42 dB	32-39 dB	32-41 dB	32-41 dB	33-38 dB	33-42 dB
<b>Fan CFM</b>	110.5-141.3	110.5-162.7	110.5-141.3	110.5-162.7	110.5-141.3	110.5-162.7	110.5-141.3	110.5-162.7
<b>Weight</b>	51 lbs (23 kg)	51 lbs (23 kg)	53 lbs (24 kg)	53 lbs (24 kg)	51 lbs (23 kg)	51 lbs (23 kg)	57 lbs (26 kg)	57 lbs (26 kg)

\* 60 Hz must be maintained or the sound levels (dB) may change.

## Sequence of Operations

1. The blower (combustion) motor fan starts and purges the combustion and heat exchanger chambers making sure that they are clear. The green LED light is on.
2. The blower stages down and the ignition module powers the spark igniter and spark occurs. When the spark is sensed as being correct, the PCB allows voltage to the solenoid gas valves and gas enters the chamber. Ignition occurs and the flame rod begins to prove flame. The blower motor stages back up to high. When the burner is on the LED glows red indicating the burner is on. If the flame is correct and a secure ground is available, then the flame rod produces micro-amps and the unit will fire trying to reach your set room temperature.
3. The convection (room blower) will start on low speed circulating warm air into the structure. After the PCB compares the set temperature to the room temperature, the seven stage gas valve and fan control will fire the unit at the most efficient rate to obtain the comfort level as set.
4. The negative co-efficient thermistor will sense the room temperature at the floor level and will provide feedback to the PCB to determine the firing rate, fan speed, and run time. When the set temperature is reached, the red indicator will return to green indicating the burner is off. The convection fan will continue to run cooling the exchangers and electronics for about 4 minutes.
5. The LED will be green indicating the unit is on standby. When the structure temperature drops, the process starts over again.
6. Fresh air for combustion is drawn from outside and exhaust air is eliminated to the outside. Moisture coming from the vent outside is normal as most high efficient units produce moisture.

# Fault Isolation

If there is a malfunction the appliance may shut down as a safety precaution and display a fault code to assist in diagnosing the problem. The fault code will flash in the display on the control panel.

Fault codes should be used to assist in identifying the cause of the failure.

After the problem has been corrected, the fault code will clear only after the appliance has been turned off and back on. The code will be stored into the memory.

Some faults may cause a hard lockout where the appliance shuts off and corrective action is required before the appliance will operate.

## Accessing Fault Codes

Up to 10 fault codes are stored in the PC Board and can be recalled by simultaneously pressing the "Economy" button and both temperature control buttons for 2.5 seconds while the appliance is turned OFF. After the buttons are released, the fault codes will be displayed in 2 second intervals beginning with the most recent fault code.

Models with analog controls and models with digital LED's each have their own set of fault codes.

### Models with analog controls:

The fault code will display by lighting up 1 to 4 of the temperatures at the same time. For example, if the temperatures 60, 64, and 68 are lit up then the fault code is 60\*64\*68 - Abnormal Combustion Fan RPM.

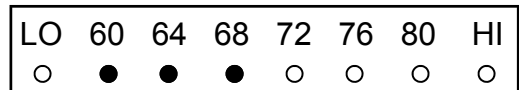

### On models RHFE-431WTA, RHFE-556WTA, RHFE-556FTRA:

Under SET the codes in memory are numbered 1 through 10 with "1" as the most recent. Under ROOM the fault code will be displayed.

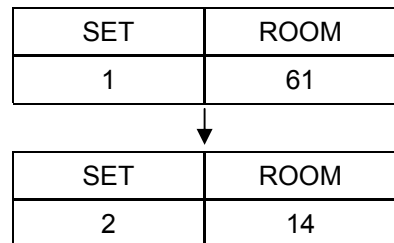

### On models all other models with digital controls:

The codes in memory are numbered 1 through 10 with "1" as the most recent. The temperature display will show "1" and then show the most recent fault code. A "2" will then be displayed followed by the second most recent fault code. The 10 most recent fault codes will be displayed in this manner.

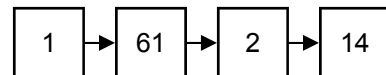

## Accessing Operation History

RHFE-431WTA,  
RHFE-556WTA,  
RHFE-433RWTA,  
RHFE-558RWTA

RHFE-201FA,  
RHFE-263FA,  
RHFE-263FAII,  
RHFE-1004FA,  
RHFE-556FTRA,  
RHFE-1004RFA,  
RHFE-1004FTA

RHFE-201RFA,  
RHFE-263RFA,  
RHFE-433RFA,  
RHFE-558RFA,  
RHFE-202FTA,  
RHFE-265FTA

After the fault codes, the heater will display the combustion hours, combustion cycles (number of times the unit is turned on and off), and power failure frequency.

SET	ROOM
50	82
18	42
1	25

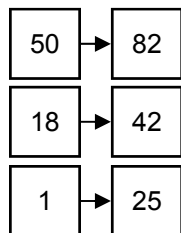

5082 combustion hours

18420 combustion cycles (multiply displayed number by 10)

125 power failures

### RHFE-431FA, RHFE-556FA

After the fault codes, the heater will display the combustion hours and combustion cycles (number of times the unit is turned on and off). The combustion time will display first in two parts followed by the combustion cycles displayed in two parts.

#### Combustion Time

- The temperature display will indicate a 16 digit binary number. A light indicates a "1". A position not lighted, indicates a "0". Read this number using the example below.

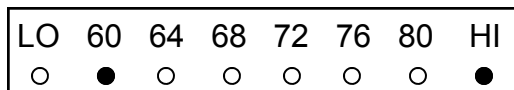

This indicates the first 8 digits as follows: 0 1 0 0 0 0 0 1

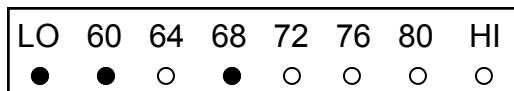

This indicates the next 8 digits as follows: 1 1 0 1 0 0 0 0

- Use a calculator with binary and decimal functions. Set the calculator to binary, "BIN", and enter the 16 digits. (0 1 0 0 0 0 0 1 1 1 0 1 0 0 0 0 in the example above.)
- Press the decimal function, "DEC", and the combustion time in hours will display. The combustion hours in this example is 16848.

#### Combustion Cycles

- The temperature display will indicate a 16 digit binary number. A light indicates a "1". A position not lighted, indicates a "0". Read this number using the example below.

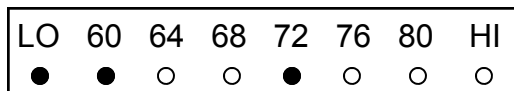

This indicates the first 8 digits as follows: 1 1 0 0 1 0 0 0

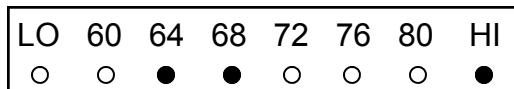

This indicates the next 8 digits as follows: 0 0 1 1 0 0 0 1

- Use a calculator with binary and decimal functions. Set the calculator to binary, "BIN", and enter the 16 digits. (1 1 0 0 1 0 0 0 0 0 1 1 0 0 0 1 in the example above.)
- Press the decimal function, "DEC", and multiply the displayed number by 10 to obtain the combustion cycles. The combustion cycles in this example is 512,490.



## Fault Isolation Codes

<u>Analog Indicator Light</u>	<u>Digital LED</u>	<u>Name</u>	<u>Definition</u>	<u>Corrective Action</u>
LO-HI	PF -- :--	Power Failure	Electric power has been lost while the appliance was running	Check that the power cord is firmly inserted into the electrical outlet. Check the 3 amp fuse. Check whether the fuse or breaker has blown at
60	11	Missed Ignition	Flame rod current does not reach 1.0 microamp within a certain time after the solenoid opens.	Check that the flame rod is firmly positioned. Check the flame rod lead. Check the flame rod for carbon build up. Check that the correct gas is being used. Check the supply pressure at the meter and at the appliance. Check that there are no leaks in the gas supply line or appliance. Check for air in the gas supply.
LO	12	Flame Failure	Flame rod current remains below 1.0 microamp for 3 seconds during initial combustion	Check that the correct gas is being used. Check the supply pressure at the meter and at the appliance. Check that there are no leaks in the gas supply line or appliance. Check for air in the gas supply.
68	14	Overheat Safety Device	High limit temperature thermistor or thermal fuse has activated	Check that the correct gas is being used. Check the supply pressure at the meter and at the appliance. Check that the flue terminal is not blocked. Check that the air filter is not blocked. Check that the warm air flow is not blocked. (There should be a clearance of 40 inches in front of the appliance.)
HI	16	Over Temperature Cut Off	Room temperature is above 104°F for longer than 10 minutes	Check that the correct gas is being used. Check the supply pressure at the meter and at the appliance. Check that the flue terminal is not blocked. Check that the air filter is not blocked. Check that the warm air flow is not blocked. (There should be a clearance of 40 inches in front of the appliance.)
72 76	31	Room Temperature Thermistor Disconnection	Room temperature thermistor circuit is open	Check the circuit. (troubleshooting)
76 80	32	Room temperature thermistor short circuit	Room temperature thermistor wire is trapped or touching bare metal.	Check the circuit. (troubleshooting)

## Fault Isolation Codes

<u>Analog Indicator Light</u>	<u>Digital LED</u>	<u>Name</u>	<u>Definition</u>	<u>Corrective Action</u>
64 68 72	33	High-limit thermistor disconnection	High limit thermistor circuit is open.	Check the circuit. (troubleshooting)
68 72 76	34	High-limit thermistor short circuit	High limit thermistor wire is trapped or touching bare metal.	Check the circuit. (troubleshooting)
LO 60 64	53	Abnormal spark sensed	<ul style="list-style-type: none"> <li>• Sparker is not off within 20 seconds of ignition.</li> <li>• 1st spark is not sensed within 2 seconds</li> <li>• 2nd spark is not continuous for 1 second after solenoid valve opens</li> </ul>	Replace sparker
60 64 68	61	Abnormal Combustion Fan RPM	RPM is not achieved within a certain time or exceeds the RPM limit.	Check for obstacle preventing fan from turning freely. Check wiring harness to motor for damage or loose connections.
64 68	70	ON/OFF Switch Failure	The ON/OFF switch connects continuously for more than 15 seconds.	Check the circuit. (troubleshooting) Replace switch.
LO 60	71	Solenoid Valve Failure	For either solenoid valve, SV1 or SV2, the signal and response signal are different.	Check the circuit. (troubleshooting) Replace gas valve.
80	72	Flame Rod Failure	Flame rod output does not cease within 20 seconds	Check the circuit. (troubleshooting) Replace flame rod.
72 76 80 HI	73	Communication Failure	Data transfer between CPU and E2PROM fails.	Disconnect the power and re-apply power.
NA	49	Pressure Sensor	No signal from the pressure sensor.	Check the circuit. (troubleshooting)
NA	99	Flue Block	The pressure sensor signal is below its limit.	Check the flue and termination for proper installation and blockage.
60 64 68 72 76	NA	Flue Block	Flue blockage has been detected based on fan speed.	Check the flue and termination for proper installation and blockage.

## Fault Isolation - Other Issues

---

### **AT IGNITION:**

Heater does not operate.	⇒	Is the heater plugged in? Have the fuses or breaker blown at the fuse box / breaker panel? Is there a power failure? Is the air filter blocked? Is anything blocking the outlet for the hot air? Is the flue blocked?
Warm air does not flow when the burner lights.	⇒	The fan is started automatically after a short delay. This is to allow the heat exchanger to warm up, helping to avoid cold draughts.
Smoke or strange smells are produced on the first trial light up after installation.	⇒	This is caused by grease, oil, or dust on the heat exchanger and will stop after a short time.
Sharp clicking noised at ignition, or when unit shuts down, or goes out.	⇒	This is simply expansion noise from the heat exchanger.

### **DURING COMBUSTION:**

Clunking noise when the thermostat operates.	⇒	This is the sound of the solenoid gas valves opening and closing.
Unit is not heating room.	⇒	Is the air filter blocked? Is the set temperature high enough? Is the warm air outlet blocked by anything? Are the doors and windows of the room closed? Was the appliance correctly sized for the space?
Air filter is blocked or the louvers are blocked.	⇒	Allow heater to cool, clean air filter, and operate again.
Heater will not re-ignite after overheating	⇒	Even after unit has cooled down, the heater does not ignite again. Repair is necessary by a qualified service provider.

### **DURING COMBUSTION:**

Convection fan continues to run after turning OFF	⇒	This is to remove the residual heat from the heat exchanger. The fan will stop when the heater cools down.
---	---	--

### **OTHER POINTS:**

Steam is discharged from the flue terminal.	⇒	High efficiency appliances tend to discharge water vapor on cold days. This is normal.
Unit shuts off without apparent reason.	⇒	Check whether filters are blocked. Dirty filters will cause the heater to overheat.
Power Failure	⇒	Switch OFF, then ON again when power is restored to re-set controls.

**! WARNING**

There are a number of live tests that are required when fault finding this product. Extreme care should be used at all times to avoid contact with energized components inside the furnace.

You **MUST** be a qualified service person before proceeding with these test instructions.

Before checking resistance readings, turn off power source to unit and then isolate each item to be checked from the circuit by unplugging it.

When setting gas pressures on one of these units, please check the complete model number you are troubleshooting. Gas pressures and dip switches can vary among models. Always check the rating plate for complete information and follow directions.

**(AC IN) (Connector B)**

Black-White	120 VAC	CONNECTOR B	Pin # 1-2
Black-Ground	120 VAC		Pin #2-Ground
White-Ground	0 VAC		Pin #1-Ground

**(TR) Transformer: (Connector C) (AC Out)**

Read voltage across:	Voltage Potential	Read resistance	Pin Numbers
Grey-Grey	90-110 VAC	3-6Ω	Pin #1-7
Red-Yellow	30-42 VAC	0.8-1.5Ω	Pin #4-5
Blank pin-Grey	15-21 VAC	0.6-1.2Ω	Pin #6-7
Grey-Black	180-220VAC	155-260Ω	Pin #7-8

**(SP) Sparker: (Connector D) (Voltage potential while Sparking)**

Read voltage across:	Voltage Potential	Read resistance	Pin Numbers
Red-Blue	85-100 VAC	100K-120K Ω	Pin #3-6

The spark must be sensed as being at the correct location and intensity before it will allow the gas valve to open. Check across Pin # 1-2 at Connector F and you should read 4-6 VDC potential. When sparking, if the spark is in the right location and intensity the voltage potential will drop to almost 0 (zero) and then return to the 4-6 VDC potential.

**(SV1 and SV2) Main Solenoid Valves: (Connector D)**

Read voltage across:	Voltage Potential	Read resistance	Pin Numbers
Black-Yellow	85-90 VDC	700-1000 Ω	Pin #1-4

\*Resistance across each coils terminals should be 1400-2000 Ω when isolated.

**(POV) Modulating Gas Valve (Connector G)**

Read voltage across:	Voltage Potential	Read resistance	Pin Numbers
Grey-Grey	6-16 VDC	80-90 Ω	Pin #2-6

**(BL) Combustion Blower Motor: (Connector G) DC Motor 37VDC 8 Watts**

Read voltage across:	Voltage Potential	Read resistance	Pin Numbers
Black-White	7-12 VDC	8K-10K Ω	Pin #7-8
Yellow-White	4-5 VDC	4K-6K Ω	Pin #4-8
Red-White	10-30 VDC	N/A	Pin # 3-8

**(FM) Convection Fan Motor: (Connector E) Variable 100VAC Motor 60 Hz**

Read voltage across:	Voltage Potential	Read resistance	Pin Numbers
Black-Red	37-105 VAC	100-120 Ω	Pin #1-2

\* Be sure to check for obstructions to blades. Check the capacitor before replacing motor.

**(PS) Pressure Sensor: (Connector A) Omron Electronic Pressure Switch**

Omron Electronic	0.31 in (8.0 mm) WC <b>ON</b>	0.11 in (2.8 mm) WC <b>OFF</b>	5 VDC
------------------	----------------------------------	-----------------------------------	-------

Note: Insure clear and black hose from pressure switch to blower air chamber is not blocked or crimped with any obstructions including spider webs.

**(TF 216°C, OHS1 90°C, OHS2 70°C) (Connector G) Safety Circuit:**

Disconnect connector G from PCB. Check for continuity reading from Pin #1 to Pin #5 on the wiring harness White to White wires. If you do not read continuity through this circuit, locate open thermal fuse, bimetal OHS1, or bimetal OHS2, and replace. You must immediately determine what caused the overheat situation and correct. Check combustion specifications, gas pressures, gas type, and for any obstructions to air flow.

**(R.TH) Room Thermistor: (Connector H) Negative Co-efficient Thermistor**  
(the resistance decreases as the temperature increases)

Disconnect connector H from PCB. Set your meter to the 200K Ω scale. Place your meter leads into Yellow to Yellow. Apply heat to the thermistor bulb. The resistance will decrease. Apply cold and the resistance will increase. Examples of readings:  
41°F=91KΩ 50°F=65KΩ 68°F=39KΩ 86°F=23KΩ

**(OH.TH) Over Heat Thermistor: (Connector H)**

Disconnect connector H from PCB. Set your meter to the proper Ω scale. Place your meter leads into White to White. A reading below 0.38kΩ indicates a short. A reading above 1255kΩ indicates an open circuit or broken wire. Insure air flow is not obstructed.

**(FR) Flame Rod (Connector C1)**

Set your meter to read micro-amps (μ). Disconnect connector C1 and place your meter in series with the Yellow to Yellow wires. Upon flame development you should read 1 -2 micro-amps. Depending on gas type and firing rate you should read 4 to 8 micro-amps. You must have a grounded and polarized electrical supply with no obstructions in burner or build up on flame rod to proof flame. The micro-amp symbol on your meter is μ.

**(Hard Lock Out Information)**

Improper sized gas lines, low pressure drops, defective or freezing pressure regulators, improper electrical supply and failure to ground, spider webs in burners, intake and exhaust air blockage of vents, broken or damaged wiring harnesses, or blown fuses can cause hard lock outs. Before replacing components in furnace, insure the above items are within the specifications. The above listed items are not a warranty issue or defect in unit.



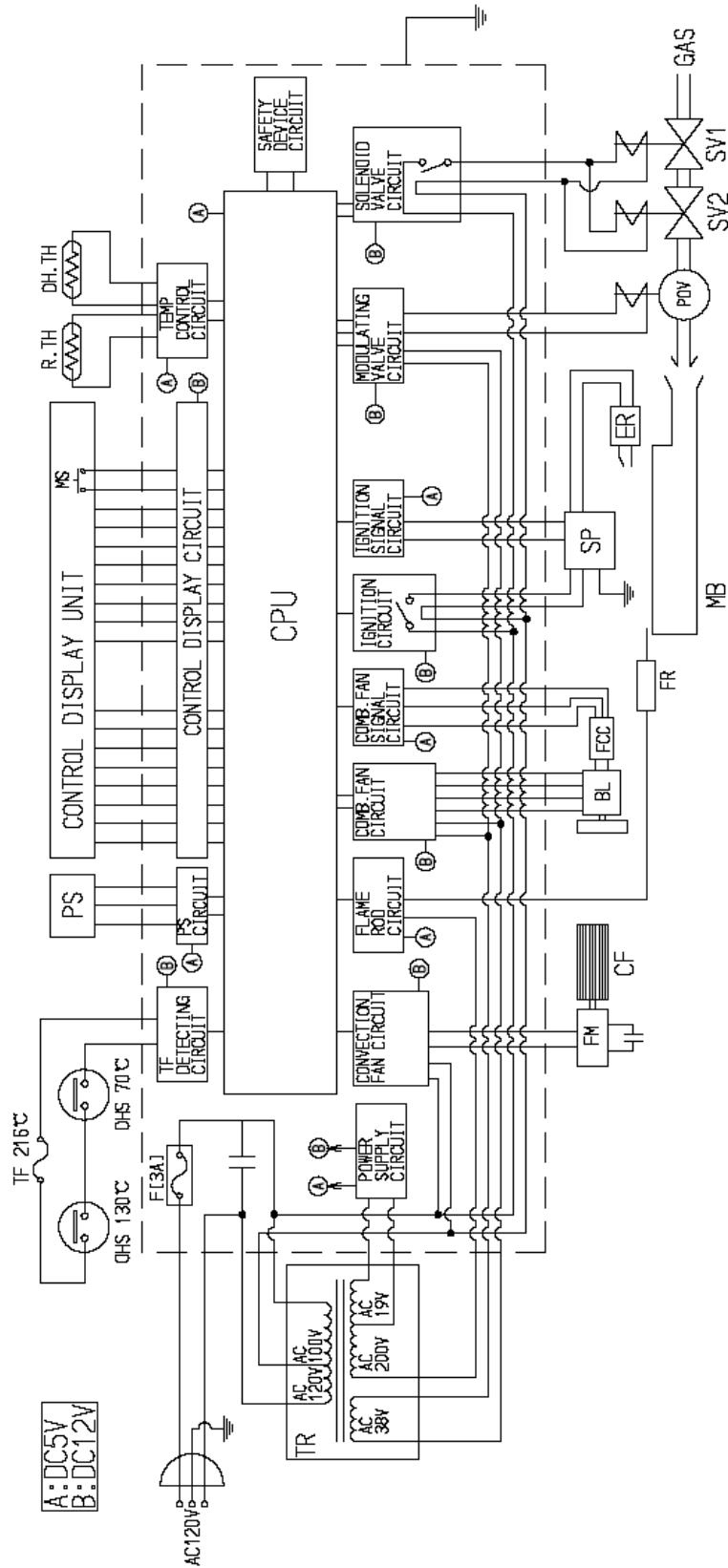

**⚠ WARNING** There are a number of live tests that are required when fault finding this product. Extreme care should be used at all times to avoid contact with energized components inside the furnace.

You MUST be a qualified service person before proceeding with these test instructions.

Before checking resistance readings, turn off power source to unit and then isolate each item to be checked from the circuit by unplugging it.

When setting gas pressures on one of these units, please check the complete model number you are trouble-shooting. Gas pressures and dip switches can vary among models. Always check the rating plate for complete information and follow directions.

**(AC IN)**

Black-White	120 VAC	Pin # 1-2
Black-Ground	120 VAC	Pin #2-Ground
White-Ground	0 VAC	Pin #1-Ground

**(TR) Transformer: (Connector CN2 AC Out)**

Read voltage across:	Voltage Potential	Read resistance	Pin Numbers
Gray - Gray	98-125 VAC	4--16 Ω	1-7
White - White	98-125 VAC	4--14 Ω	2-3
Red - Red	35 VAC	1--3 Ω	4-10
Black - Yellow	200-220 VAC	250--400 Ω	5-8
Black - Blue	12-20 VAC	1--3 Ω	8-9

**(SP) Sparker: (Connector CN4)**

Read voltage across:	Voltage Potential	Read resistance	Pin Numbers
Red-Blue	85-100 VAC	100K-120K Ω	3-6

The spark must be sensed as being at the correct location and intensity before it will allow the gas valve to open. Check across Pin # 1-2 at Connector F and you should read 4-6 VDC potential. When sparking, if the spark is in the right location and intensity the voltage potential will drop to almost 0 (zero) and then return to the 4-6 VDC potential.

**(SV1, SV2, POV) Main Solenoid Valves: (Connector CN4)**

Read voltage across:	Voltage Potential	Read resistance	Pin Numbers
SV1 - Yellow ~ Black (hold)	85-90 VDC	1400-2000 Ω	1-4
SV2 - Yellow ~ Black (assist)	85-90 VDC	1400-2000 Ω	1-4
POV - Gray ~ Gray	6-16 VDC	80-90 Ω	2-6

\*Resistance across each coils terminals should be 1400-2000 Ω when isolated.

**(BL) Combustion Fan Motor: (Connector CN8) DC Motor 37VDC 8 Watts**

Read voltage across:	Voltage Potential	Read resistance	Pin Numbers
Black-White	7-12 VDC	8-10 KΩ	7-8
Yellow-White	4-5 VDC	4-6 KΩ	4-8
Red-White	10-30 VDC	N/A	3-8



**(FM) Convection Fan Motor: (Connector CN3) AC Motor 60 Hz, 100VAC**

Read voltage across:	Voltage Potential	Read resistance	Pin Numbers
Black-Red	40-105 VAC	100-120 Ω	1-2

\* Be sure to check for obstructions to blades. Check the capacitor before replacing motor.

**(PS) Pressure Sensor: (Connector CN13) Electronic Pressure Switch, 125 V, 0.1 A**

Electronic	0.31 in (8.0 mm) WC <b>ON</b>	0.11 in (2.8 mm) WC <b>OFF</b>	5 VDC

Note: Ensure clear and black hose from pressure switch to blower air chamber is not blocked or crimped with any obstructions including spider webs.

**(RT) Room Temperature Control:**

Integrated into the PCB program and works in conjunction with the thermistor as noted below.

**(TH) Room Thermistor:**

Check thermistor by inserting meter leads into each end of thermistor plug. Set your meter to the 200 KΩ scale. Apply heat to the thermistor bulb and the resistance should decrease. Apply cold and the resistance should increase. Examples of readings:  
41°F=91KΩ 50°F=65KΩ 68°F=39KΩ 86°F=23KΩ

**(FR) Flame Rod**

Set your meter to read micro-amps (μ). Located on the combustion chamber, the flame rod proves flame for proper operations. A properly grounded electrical supply is a must. Flame rod current through this rod should range between 4 to 8 micro amps depending on gas type. Low fire flame current should be 1.2 to 2.0 micro amps.

***Improperly setup and /or converted units can soot and cause hard lockouts. If carbon is found on the flame rod, clean the carbon from it. Then you need to confirm your manifold differential gas pressure on Hi fire and Lo fire is correct. Insure primary and secondary air dampers are correct. Also, check to ensure proper orifices were placed in the unit..***

**IMPORTANT INFORMATION CONCERNING HARD LOCKOUTS:**

Other items that can cause hard lockouts are: improper sized gas lines, low gas pressures or pressure drops due to other appliances on the gas system, spider webs in the burner and air intake of vent system, improper ground or no ground at receptacle, supply regulators freezing up or defective, voltage drops or bad receptacles, winds in excess of 40 mph causing turbulence inside the vent terminal, etc.

**(OHS1, OHS2, TF) Safety Circuit Check: CN8**

Check for continuity reading from pin #1 white wire to pin #5 white wire. If you do not read continuity through this circuit, locate defective switch and replace that component. Then determine what caused overheat condition.

**(MS) Main Switch: CN11**

Disconnect CN11 from PCB, being careful not to break wires. Read Blue to Blue, pin #9 and 10 on 40KΩ . When ON/OFF is in the ON position, you should read 10--18KΩ. When released, you should read open or 0 Ω

Wiring harness, connectors, and fuses should be checked if all above readings are normal.

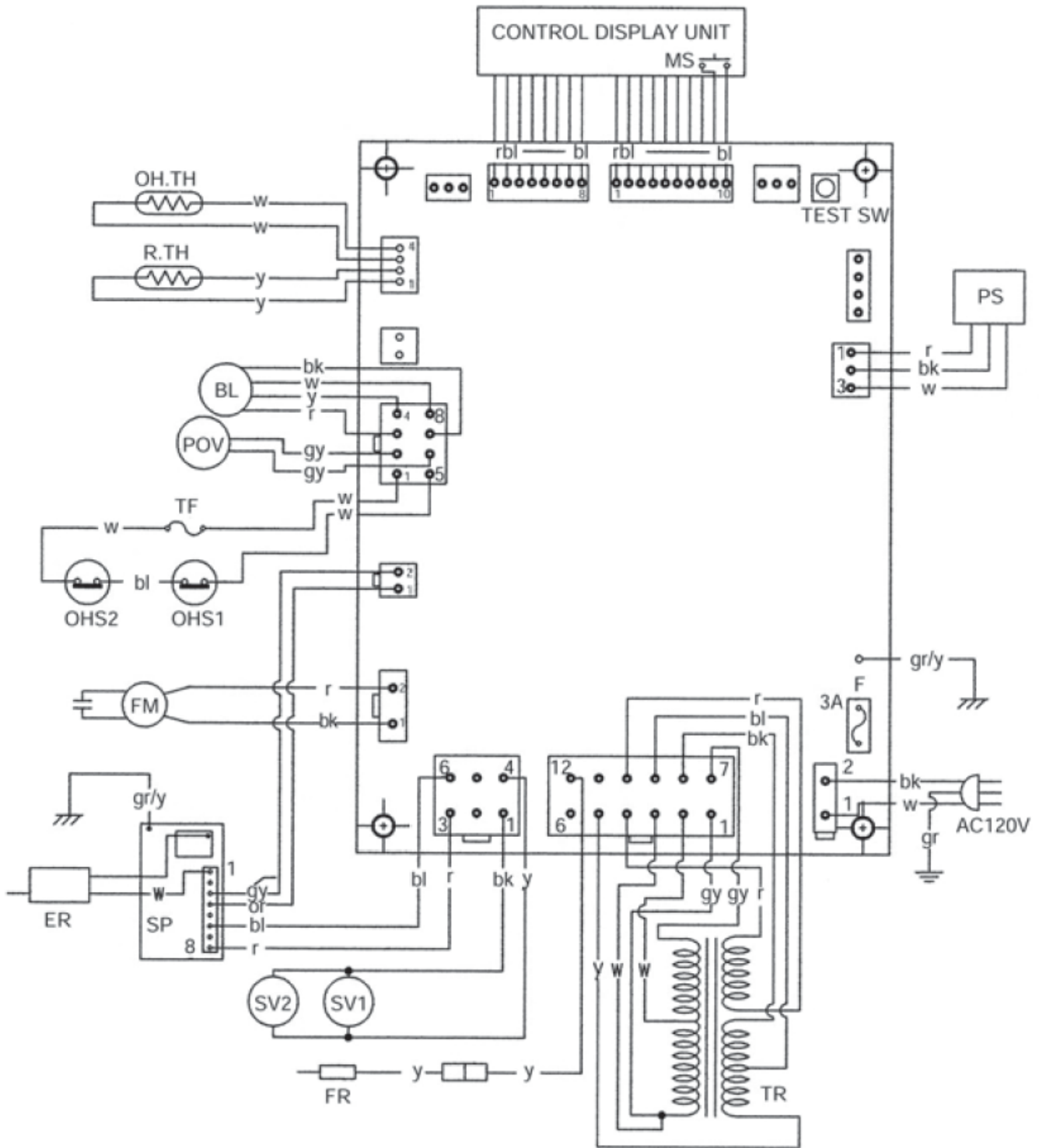



Part	Wire	202FTA	265FTA	
Control Panel	Red - Blue	DC0-5V (Pulsed voltage); Resistance is infinity, but the current flows when the switch is pushed.		
	Blue - Blue			
OHS.	White - White	Below DC 1V, Below 2Ω		
	Blue - White (OHS1)			
	Blue - White (OHS2)			
TF	White - White (TF)			
O.H. TH	White - White	0.87-482kΩ; (<0.87kΩ:Short, >482kΩ:Open)		
	Temperature	32°F (0°C):214kΩ, 68°F (20°C):78kΩ, 122°F (50°C):21kΩ 176°F (80°C):7.3kΩ, 212°F (100°C):3.6kΩ, 135°F (275°C):1.5kΩ		
	White - White (Filter sign)	High	Flashes below 4.5kΩ	
		Low	Flashes below 4.5kΩ	
	White - White (TH operates)	High	Operates below 3.4kΩ	
Low		Operates below 3.4kΩ		
Room Thermistor	Yellow - Yellow	1.82-707kΩ; (<1.82kΩ:Short, >707kΩ:Open)		
	Temperature	32°F (0°C):113kΩ, 68°F (20°C):39kΩ, 86°F (30°C):24kΩ, 104°F (40°C):15kΩ		
FR	Yellow - Yellow	Below 0.1μA (During Stop)		
Combustion Fan (In case of short vent.)	White - Black	Below ignition revolution +2Hz	Below ignition revolution +2Hz	
	Ignition revolution	Initial	LP: 75Hz, NG: 80Hz	LP: 80Hz, NG: 85Hz
		Re-attempt	LP: 75Hz, NG: 80Hz	LP: 80Hz, NG: 85Hz
	Normal revolution	High	LP: 110Hz, NG: 110Hz	LP: 128Hz, NG: 118Hz
Low		LP: 83Hz, NG: 83Hz	LP: 82Hz, NG: 81Hz	
Combustion Fan (In case of long vent.)	White - Black	-	Below ignition revolution +2Hz	
	Ignition revolution	Initial	-	LP: 80Hz, NG: 85Hz
		Re-attempt	-	LP: 80Hz, NG: 85Hz
	Normal revolution	High	-	LP: 128Hz, NG: 128Hz
Low		-	LP: 82Hz, NG: 89Hz	
Ignitor	Red - Blue	90-120V		
SV	Black-White	80-100V, 1.5-2.5kΩ		
	Black-Yellow			
Modulating Valve	Red-White	DC2-15V (Low-High), 60-90Ω		
Convection Fan	Red - Black	50-110V, 90-180Ω		
Pressure Sensor	Red - White	DC3 - 7V		

Transformer	60Hz-120V
Gray - Gray	AC108-132V, 5-20Ω
White - White	AC95-120V, 5-20Ω
Red - Red	AC20-40V, 0.5-2.0Ω
Brown - Brown	AC10-30V, 1-5Ω
Black - Blue	AC10-30V, 1.0-3.0Ω
Black - Yellow	AC200-240V, 200-450Ω

# Wire Diagram

RHFE-202FTA  
RHFE-265FTA

MARK	PART NAME	MARK	PART NAME
MS	MAIN SWITCH	OH.TH	OVER HEAT THERMISTOR
R.TH	THERMISTOR	OHS1, 2	OVER HEAT SWITCH 1, 2
TF	THERMAL FUSE	FM	CONVECTION FAN MOTOR
F	FUSE	SP	SPARKER
ER	ELECTRODE	SV1, 2	MAIN SOLENOID VALVE 1, 2
POV	MODULATING SOLENOID VALVE	BL	COMBUSTION FAN MOTOR
TR	TRANSFORMER	PS	PRESSURE SENSOR
FR	FLAME ROD		

CODE	COLOR
bk	black
bl	blue
gr	green
gr/y	green/yellow
r	red
w	white
y	yellow
gy	gray
or	orange
br	brown

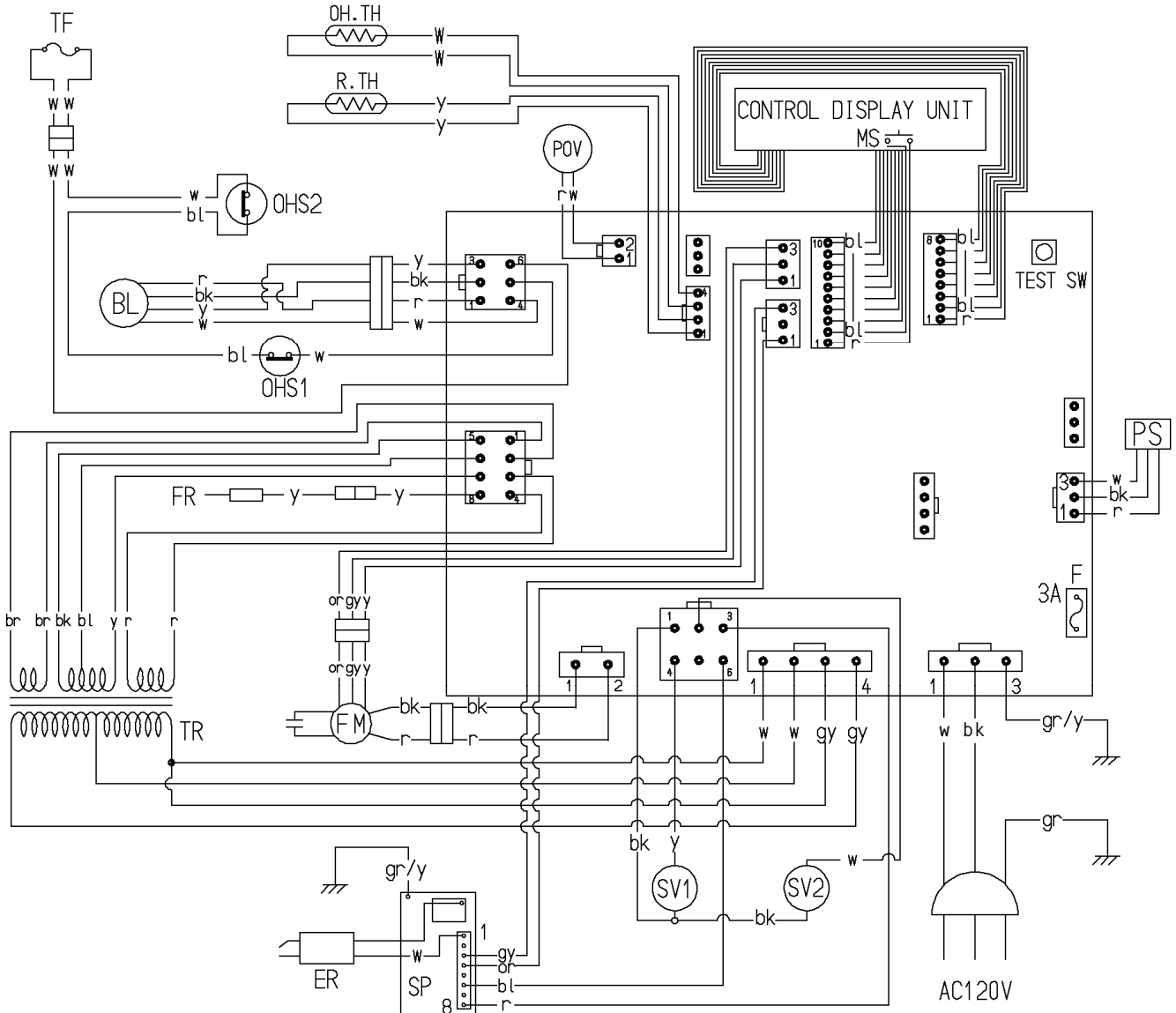

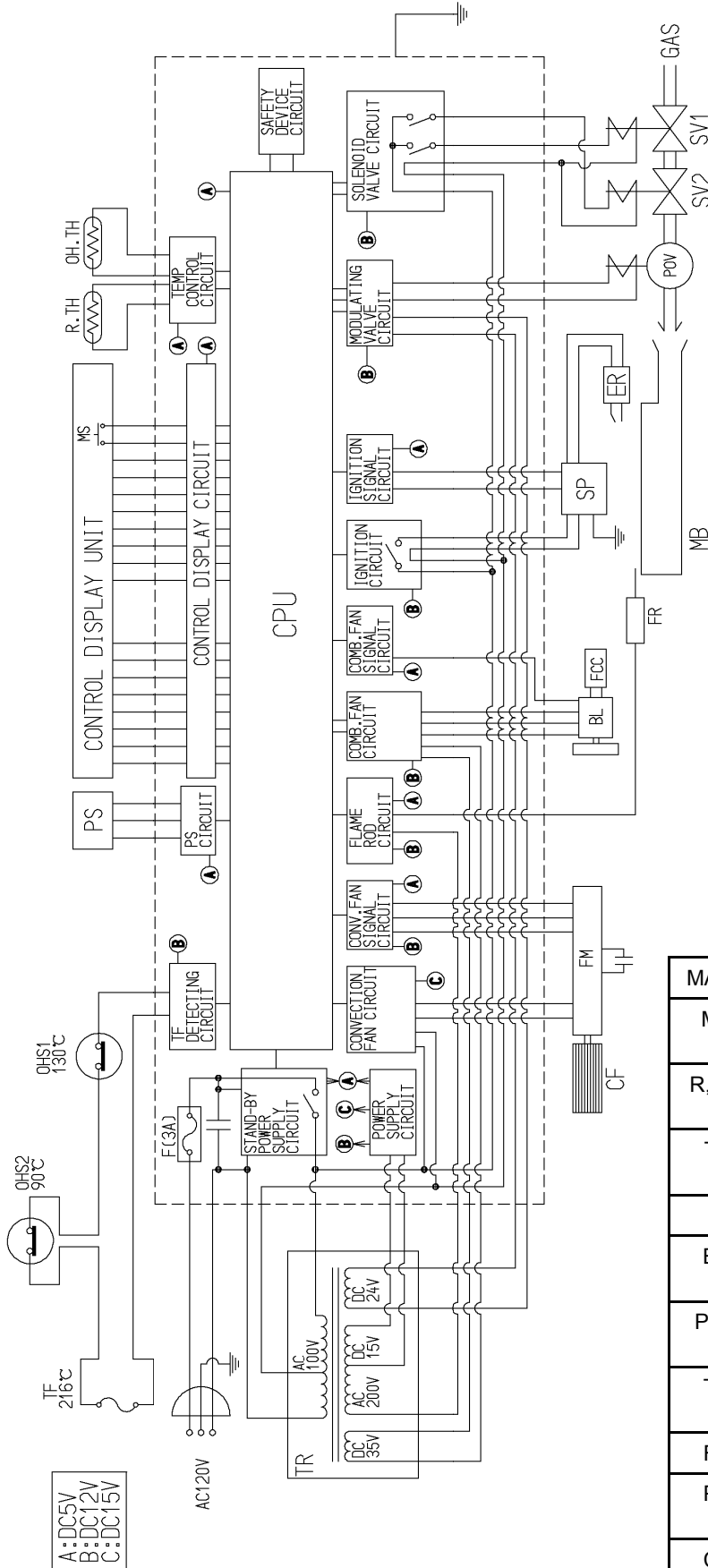

CODE	COLOR
bk	black
bl	blue
gr	green
gr/y	green/yellow
r	red
w	white
y	yellow
gy	gray
or	orange
pk	pink
br	brown
lb	light blue

MARK	PARTS NAME	MARK	PARTS NAME
MS	Main switch	OH, TH	Over heat thermistor
R, TH	Thermistor	OHS1, 2	Over heat switch 1,2
TF	Thermal fuse	FM	Convection fan motor
F	Fuse	SP	Sparker
ER	Electrode	SV1, 2	Main solenoid valve 1,2
POV	Modulating solenoid valve	BL	Combustion fan motor
TR	Transformer	FCC	Fan control circuit
FR	Flame rod	MB	Main burner
PS	Pressure sensor	CPU	Central processing unit
CF	Convection Fan		

**⚠ WARNING**

There are a number of live tests that are required when fault finding this product. Extreme care should be used at all times to avoid contact with energized components inside the furnace.

You **MUST** be a qualified service person before proceeding with these test instructions.

Before checking resistance readings, turn off power source to unit and then isolate each item to be checked from the circuit by unplugging it.

When setting gas pressures on one of these units, please check the complete model number you are trouble-shooting. Gas pressures and dip switches can vary among models. Always check the rating plate for complete information and follow directions.

**(TR) Transformer:**

Read Voltage across:

WIRE COLOR	VOLTAGE	RESISTANCE	PIN NO.
White - White	98 - 105 VAC	6 - 19 ohms	26 - 30
Red - Red	28 - 50 VAC	1 - 3 ohms	24 - 28
Black - Blue	10 - 15 VAC	0.5 - 2 ohms	25 - 29
Blue - Yellow	130 - 185 VAC	200 - 400 ohms	23 - 29
Gray - Gray	110 - 120 VAC	10 - 14 ohms	19 - 20

**(SP) Sparker Board:**

WIRE COLOR	VOLTAGE	RESISTANCE	PIN
Blue - Red	85 - 110 VAC	see below	33 - 36

Set your voltage meter on the 400k scale, unplug the (5) pin connector on the sparker board. When reading across the two lugs the blue and red wire connect to, you should read somewhere between 100k and 120k ohms of resistance. When checking the spark sensing circuit, check across the orange wire (pin #35) and grey wire (pin #32) on your 40 VDC scale. You should read between 4 - 5 VDC. During the spark this voltage will drop to approximately 0 VDC. Once unit ignites the voltage will go back up to 4 - 5 VDC.

**(POV, SV1, and SV2) Gas valve solenoids:**

WIRE COLOR	VOLTAGE	RESISTANCE *	PIN NO.
Gray - Gray	4.5 VDC low fire to 11.5 VDC high fire	80 - 100 ohms	43 - 45
Black - Yellow	85 - 90 VDC	1,300 - 2,000 ohms	31 - 34

\*Remember, when reading the resistance of a solenoid coil, you should read across the lugs on the coil.

**(BL) Combustion Motor:**

NOTE: If your meter does not have a hertz scale, please refer to voltage and resistance readings listed below. If you have a hertz scale, check the following items first. Hertz reading across black - white wires, pins 41 and 42.

RHFE-431 - LP UNITS	RHFE-556 LP UNITS
Lo fire - 44 Hz.	Lo fire - 47 Hz.
Hi fire - 81 Hz.	Hi fire - 106 Hz.

RHFE-431 NG UNITS	RHFE-556 NG UNITS
Lo fire - 44 Hz.	Lo fire - 48 Hz.
Hi fire - 81 Hz.	Hi fire - 106 Hz.

**Voltage and resistance check for (BL).**

WIRE COLOR	VOLTAGE	RESISTANCE	PIN NO.
Red - Yellow	1-2 VDC low fire to 7.6 -18 VDC high fire	1.2 - 1.8 mega ohms	39 - 40
Black - White	N/A	9.4 k - 9.9 k ohms	41 - 42

**(FM) Convection fan motor:**

WIRE COLOR	VOLTAGE	RESISTANCE	PIN NO.
Red - Gray	80-94 VAC low fire to 95-104 VAC high fire	90-180 ohms	21 - 22

**(TH) Thermistor:**

Check the thermistor by inserting meter leads into each end of the thermistor plug. Set your meter to the 200k scale and read resistance. You should be able to apply heat to the thermistor bulb and see the resistance decrease. Then apply ice to the thermistor bulb and the resistance should increase.

EXAMPLES: 41 °F = 91 k ohms  
50 °F = 65 k ohms  
68 °F = 39 k ohms  
86 °F = 23 k ohms

**(FR) Flame Rod:**

Flame rod - yellow wire = pin #27. Low fire current should be 1.3 to 2.0 micro amps (Fa). High fire current should be 4 to 8 micro amps, depending on gas type being used.

**NOTE:** Improperly setup and/or converted units can soot and cause carbon to accumulate on flame rods. This will cause hard lockouts. If carbon is found on the flame rod, remove and clean carbon from rod. Then you will need to confirm manifold gas pressure, proper air dampers and ensure vent is clear. Also, check for proper orifices.



**(H<sub>1</sub>, H<sub>2</sub> and H<sub>3</sub>) Safety Circuit:**

Check for continuity across pins 44 and 46 at terminal H on the PC board. If you have no continuity, this means one of these switch/thermal fuses is open. Replace defective component.

**(OH - TH) Overheat Thermistor:**

Check resistance reading across pins 12 and 13 at terminal A on the PC board. Proper readings should be 0.6 k and 523 k. A reading below 0.6 k ohms indicates a short and a reading above 523k indicates an open circuit.

**(MS) On/Off Control:**

To check to ensure the on/off button is functioning, unplug terminal I. Place (1) lead of your meter on the red wire for pin #66 and the other lead on the blue wire for pin#68. Now press the on/off button and you should be able to read continuity through this switch each time the button is pressed.

**(TB) Terminal Block:**

This terminal is located on the right rear upper portion of the unit. On direct vents the jumper should be across terminals 2 and 3. On units with vent extensions over four feet, this jumper should be across terminals 1 and 2.

**IMPORTANT INFORMATION CONCERNING HARD LOCKOUTS:**

Other items that can cause lockouts are: Improperly converted units, spider webs in burner and air intake of vent system, improperly sized gas lines, low gas pressures or pressure drops due to other appliances on the gas system, improper ground or no ground at receptacle, supply regulators freezing up or defective, voltage drops or bad receptacle, winds in excess of 30 to 40 MPH causing turbulence inside the vent terminal, etc.

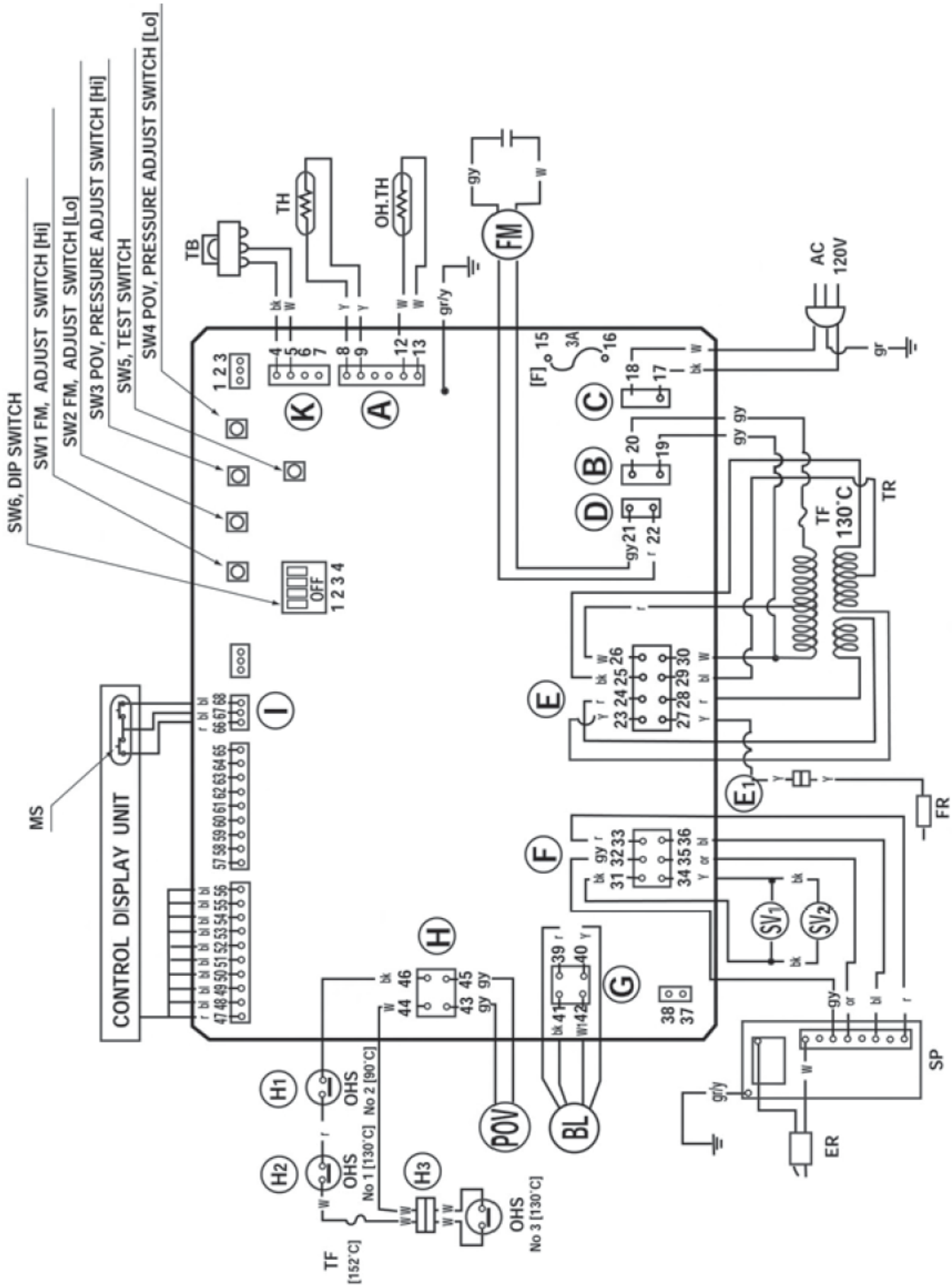



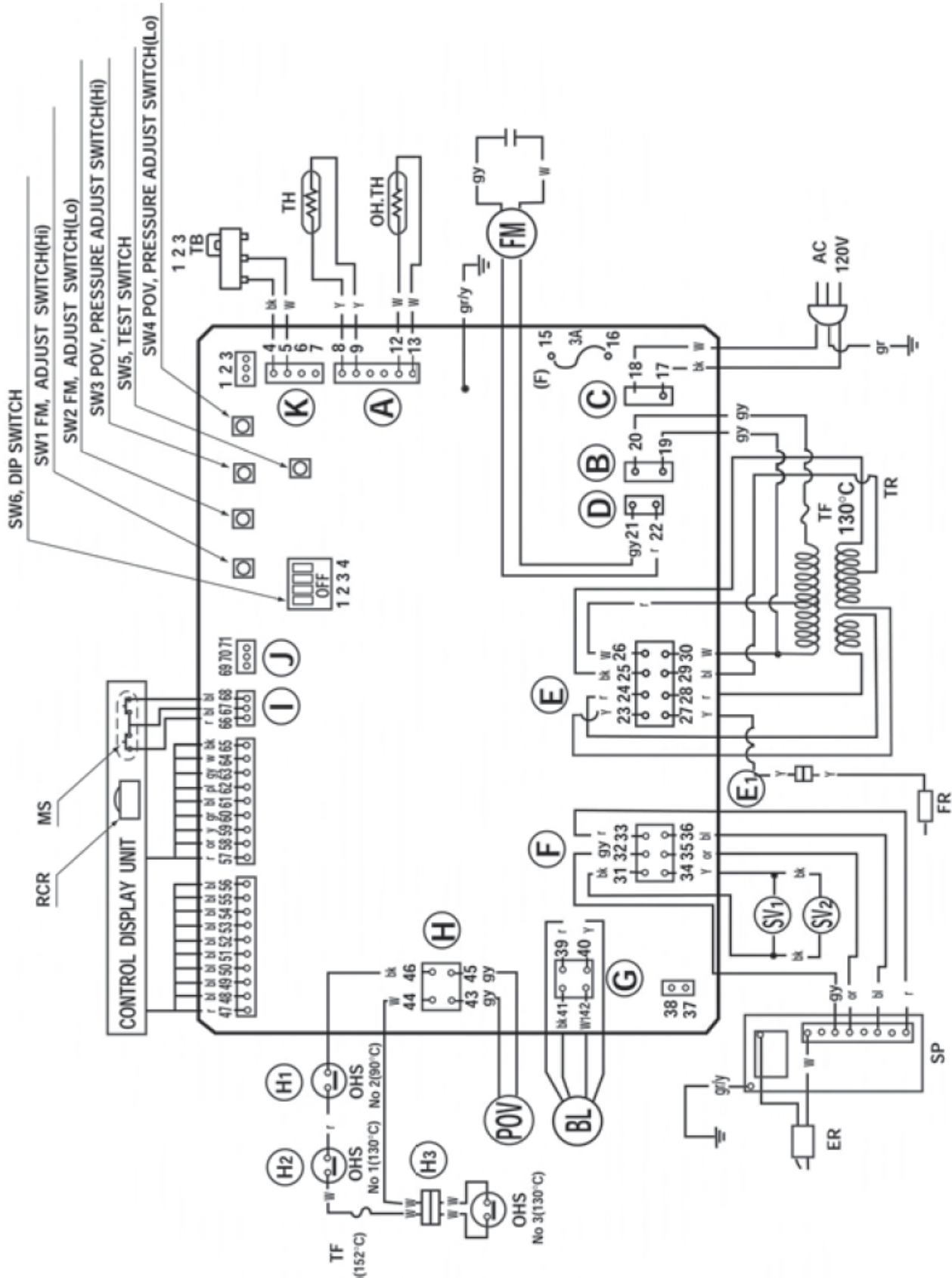

**⚠ WARNING**

There are a number of live tests that are required when fault finding this product. Extreme care should be used at all times to avoid contact with energized components inside the furnace.

You MUST be a qualified service person before proceeding with these test instructions.

Before checking resistance readings, turn off power source to unit and then isolate each item to be checked from the circuit by unplugging it.

When setting gas pressures on one of these units, please check the complete model number you are trouble-shooting. Gas pressures and dip switches can vary among models. Always check the rating plate for complete information and follow directions.

**(TR) Transformer:**

Read Voltage across:

WIRE COLOR	VOLTAGE	RESISTANCE READING	PIN NUMBERS
White - White	98 - 105 VAC	6 - 19 ohms	21 - 27
Red - Red	28 - 50 VAC	1 - 3 ohms	30 - 31
Black - Blue	10 - 15 VAC	0.5 - 2.5 ohms	22 - 23
Blue - Yellow	130 - 185 VAC	200 - 400 ohms	23 - 32
Grey - Grey	110 - 120 VAC	10 - 14 ohms	17 - 18
Purple - Purple	4.5 - 5.5 VAC	1 - 2 ohms	24 - 25
Black - Yellow	165 - 185 VAC	200 - 212 ohms	22 - 32
Brown - Purple	2.2 - 2.8 VAC	0.7 - 1.2 ohms	24 - 28

**(SP) Sparker Board:**

WIRE COLOR	VOLTAGE	RESISTANCE READING	PIN NUMBERS
Blue - Red	85 - 110 VAC	see below	33 - 36

Set your voltage meter on the 400k scale, unplug the (5) pin connector on the sparker board. When reading across the two lugs the blue and red wire connect to, you should read somewhere between 100k and 120k ohms of resistance. When checking the spark sensing circuit, check across the orange wire (pin #35) and gray wire (pin #32) on your 40 VDC scale. You should read between 4 - 5 VDC. During the spark this voltage will drop to approximately 0 VDC. Once unit ignites the voltage will go back up to 4 - 5 VDC.

**(POV, SV1, and SV2) Gas valve solenoids:**

WIRE COLOR	VOLTAGE	RESISTANCE	PIN NO.
Gray - Gray	4.5 VDC low fire to 11.5 VDC high fire	80 - 100 ohms	45 - 47
Black - Yellow	85 - 90 VDC	1,300 - 2,000 ohms	35 - 38

\*Remember, when reading the resistance of a solenoid coil, you should read across the lugs on the coil.

**(BL) Combustion Motor:**

*NOTE: If your meter does not have a hertz scale, please refer to voltage and resistance readings listed below. If you have a hertz scale, check the following items first. Hertz reading across black - white wires, pins 41 and 42.*

RHFE-431 - LP UNITS	RHFE-556 LP UNITS
Lo fire - 46 Hz.	Lo fire - 47 Hz.
Hi fire - 82 Hz.	Hi fire - 106 Hz.

RHFE-431 NG UNITS	RHFE-556 NG UNITS
Lo fire - 62 Hz.	Lo fire - 48 Hz.
Hi fire - 81 Hz.	Hi fire - 106 Hz.

**Voltage and resistance check for (BL).**

WIRE COLOR	VOLTAGE	RESISTANCE	PIN NO.
Red - Yellow	1-2 VDC low fire to 7.6 -18 VDC high fire	1.2 - 1.8 mega ohms	43 - 44
Black - White	N/A	9.4 k - 9.9 k ohms	41 - 42

**(FM) Convection fan motor:**

WIRE COLOR	VOLTAGE	RESISTANCE	PIN NO.
Red - Gray	80-94 VAC low fire to 95-104 VAC high fire	90-180 ohms	19 - 20

**(TH) Thermistor:**

Check the thermistor by inserting meter leads into each end of the thermistor plug. Set your meter to the 200k scale and read resistance. You should be able to apply heat to the thermistor bulb and see the resistance decrease. Then apply ice to the thermistor bulb and the resistance should increase. Pins 5 and 6 on the P.C. board.

EXAMPLES: 41 °F = 91 k ohms  
50 °F = 65 k ohms  
68 °F = 39 k ohms  
86 °F = 23 k ohms

### **(FR) Flame Rod:**

Flame rod - yellow wire = pin #26. Low fire current should be 1.3 to 2.0 micro amps (Fa). High fire current should be 4 to 8 micro amps, depending on gas type being used.

**NOTE:** Improperly setup and/or converted units can soot and cause carbon to accumulate on flame rods. This will cause hard lockouts. If carbon is found on the flame rod, remove and clean carbon from rod. Then you will need to confirm manifold gas pressure, proper air dampers and ensure vent is clear. Also, check for proper orifices.

### **(H<sub>1</sub>, H<sub>2</sub> and H<sub>3</sub>) Safety Circuit:**

Check for continuity across pins 46 and 48 at terminal H on the PC board. If you have no continuity, this means one of these switch/thermal fuses is open. Isolate the open switch or thermal fuse and replace the defective component.

### **(OH - TH) Overheat Thermistor:**

Check resistance reading across pins 9 and 10 at terminal A on the PC board. Proper readings should be 0.6 k and 523 k. A reading below 0.6 k ohms indicates a short and a reading above 523k indicates an open circuit.

### **IMPORTANT INFORMATION CONCERNING HARD LOCKOUTS:**

Other items that can cause lockouts are: Improperly converted units, spider webs in burner and air intake of vent system, improperly sized gas lines, low gas pressures or pressure drops due to other appliances on the gas system, improper ground or no ground at receptacle, supply regulators freezing up or defective, voltage drops or bad receptacle, winds in excess of 30 to 40 MPH causing turbulence inside the vent terminal, etc.

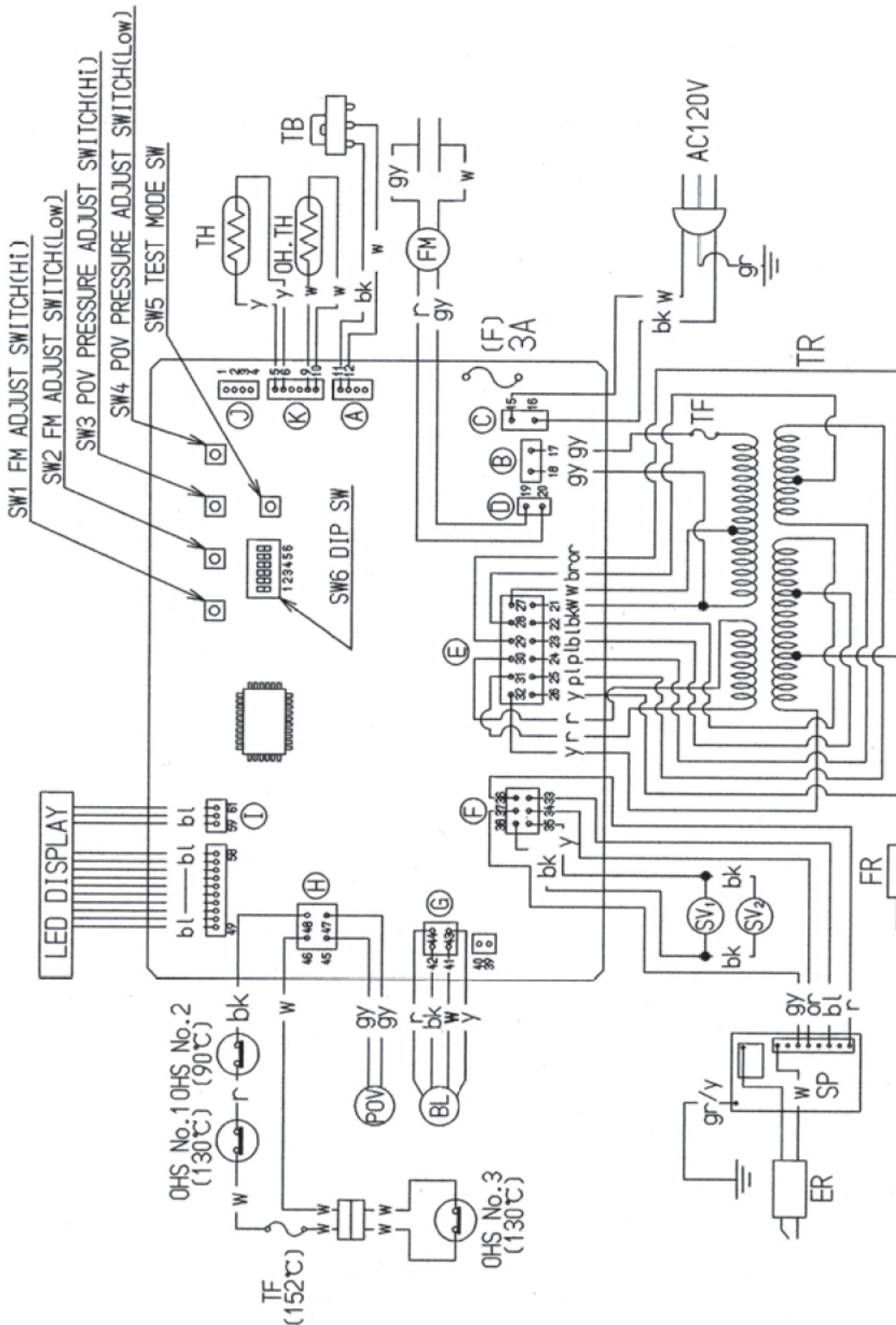





Part	Wire	433RFA	558RFA	
Control Panel	Red - Blue	Same as 263FAII		
	Blue - Blue			
OHS.	White - White	Below DC 1V, Below 2Ω		
	Blue - White (OHS1)			
	Blue - White (OHS2)			
TF	White - White (TF)			
O.H. TH	White - White	0.87-482kΩ, (<0.87kΩ:Short, >482kΩ:Open)		
	Temperature	32°F (0°C):214kΩ, 68°F (20°C):78kΩ, 122°F (50°C):21kΩ 176°F (80°C):7.3kΩ, 212°F (100°C):3.6kΩ, 135°F (275°C):1.5kΩ		
	White - White (Filter sign)	High	Flashes below 4.5kΩ	
		Low	Flashes below 4.5kΩ	
	White - White (The TH operate)	High	Operates below 3.4kΩ	
Low		Operates below 3.4kΩ		
Room Thermistor	Yellow - Yellow	1.82-707kΩ, (<1.82kΩ:Short, >707kΩ:Open)		
	Temperature	32°F (0°C):113kΩ, 68°F (20°C):39kΩ, 86°F (30°C):24kΩ, 104°F (40°C):15kΩ		
FR	Yellow - Yellow	Below 0.1μA (During Stop)		
Combustion Fan (In case of short vent.)	White - Black	Below ignition revolution +2Hz		
	Ignition revolution	Initial	LP: 65Hz, NG: 70Hz	
		Re-attempt	LP: 65Hz, NG: 70Hz	
	Normal revolution	High	LP: 105Hz, NG: 102Hz	
		Low	LP: 70Hz, NG: 69Hz	
Combustion Fan (In case of long vent.)	White - Black	Below ignition revolution +2Hz		
	Ignition revolution	Initial	LP: 65Hz, NG: 70Hz	
		Re-attempt	LP: 65Hz, NG: 70Hz	
	Normal revolution	High	LP: 105Hz, NG: 102Hz	LP: 120Hz, NG: 120Hz
		Low	LP: 70Hz, NG: 69Hz	
Ignitor	Red - Blue	90-120V		
SV	Black-Yellow	80-100V, 1.5-2.5kΩ		
Modulating Valve	Gray-Gray	DC6-16V (Low-High), 80-90Ω		
Convection Fan	Red - Black	56-75V, 90-180Ω	56-94V, 90-180Ω	
Pressure Sensor	Red - White	DC3 - 7V		
Transformer	-	Same as 263FAII		

# Wire Diagram

RHFE-433RFA  
RHFE-558RFA

MARK	PART NAME	MARK	PART NAME
MS	MAIN SWITCH	OH.TH	OVER HEAT THERMISTOR
R.TH	THERMISTOR	OHS1, 2, 3	OVER HEAT SWITCH 1, 2, 3
TF	THERMAL FUSE	FM	CONVECTION FAN MOTOR
F	FUSE	SP	SPARKER
ER	ELECTRODE	SV1, 2	MAIN SOLENOID VALVE 1, 2
POV	MODULATING SOLENOID VALVE	BL	COMBUSTION FAN MOTOR
TR	TRANSFORMER	PS	PRESSURE SENSOR
FR	FLAME ROD		

CODE	COLOR
bk	black
bl	blue
gr	green
gr/y	green/yellow
r	red
w	white
y	yellow
gy	gray
or	orange

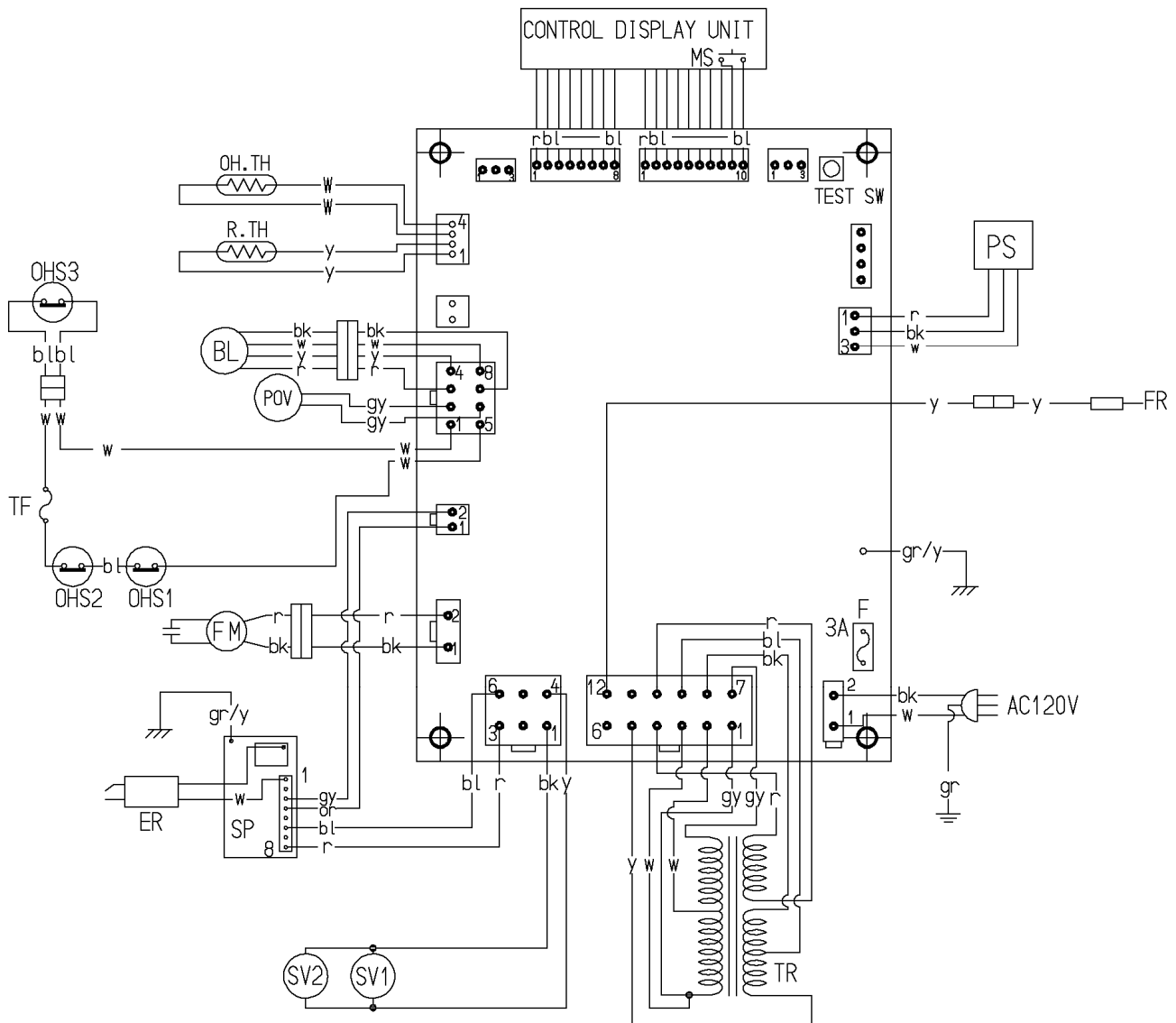

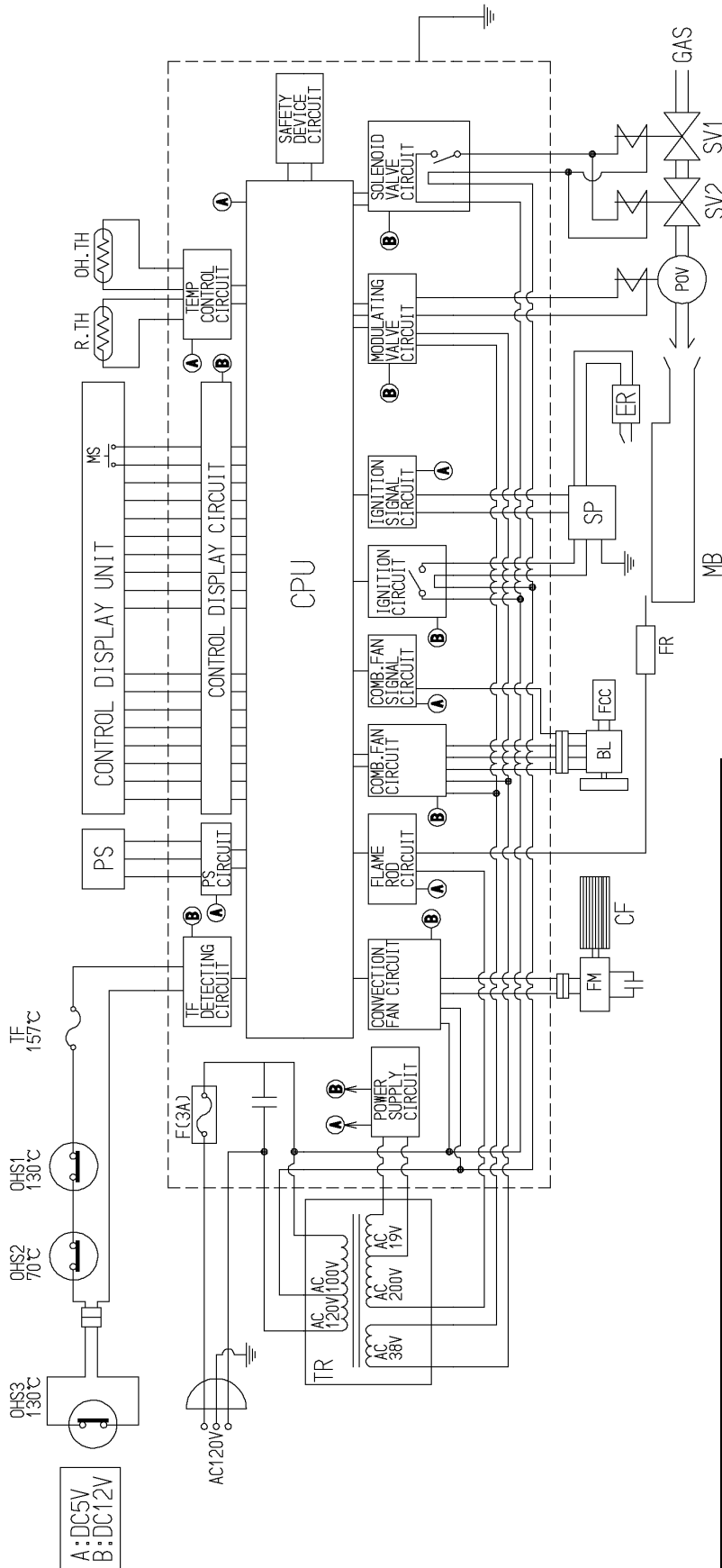

MARK	PART NAME	MARK	PART NAME
MS	MAIN SWITCH	OH.TH	OVER HEAT THERMISTOR
R.TH	THERMISTOR	OHS1, 2, 3	OVER HEAT SWITCH 1, 2, 3
TF	THERMAL FUSE	FM	CONVECTION FAN MOTOR
F	FUSE	SP	SPARKER
ER	ELECTRODE	SV1, 2	MAIN SOLENOID VALVE 1, 2
POV	MODULATING SOLENOID VALVE	BL	COMBUSTION FAN MOTOR
TR	TRANSFORMER	FCC	FAN CONTROL CIRCUIT
FR	FLAME ROD	MB	MAIN BURNER
PS	PRESSURE SENSOR	CPU	CENTRAL PROCESSING UNIT
CF	CONVECTION FAN		

Part	Wire	433RWTA	558RWTA	
OHS.	White - White	Below DC 1V, Below 2Ω	Below DC 1V, Below 2Ω	
	Blue - White (OHS1)			
	Blue - White (OHS2)			
TF	White - White (TF)			
O.H. TH	White - White	0.87-482kΩ, (<0.87kΩ:Short, >482kΩ:Open)		
	Temperature	32°F (0°C):113kΩ, 68°F (20°C):39kΩ, 86°F (30°C):24kΩ, 104°F (40°C):15kΩ		
	White - White (Filter sign)	High	Flashes below 6.83kΩ	Flashes below 6.40kΩ
		Low	Flashes below 10.2kΩ	
	White - White (The TH operate)	High	Operates below 4.97kΩ	
		Low	Operates below 7.29kΩ	
Room Thermistor	Yellow - Yellow	1.82-707kΩ, (<1.82kΩ:Short, >707kΩ:Open)		
	Temperature	32°F (0°C):113kΩ, 68°F (20°C):39kΩ, 86°F (30°C):24kΩ, 104°F (40°C):15kΩ		
FR	Yellow - Yellow	Below 0.1μA (During Stop)		
Combustion Fan (In case of short vent.)	White - Black	Below ignition revolution +2Hz		
	Ignition revolution	Initial	LP: 65Hz, NG: 70Hz	
		Re-attempt	LP: 65Hz, NG: 70Hz	
	Normal revolution	High	LP: 105Hz, NG: 102Hz	LP: 120Hz, NG: 120Hz
		Low	LP: 70Hz, NG: 69Hz	
Combustion Fan (In case of long vent.)	White - Black	Below ignition revolution +2Hz		
	Ignition revolution	Initial	LP: 65Hz, NG: 70Hz	
		Re-attempt	LP: 65Hz, NG: 70Hz	
	Normal revolution	High	LP: 105Hz, NG: 102Hz	LP: 120Hz, NG: 120Hz
		Low	LP: 70Hz, NG: 69Hz	
Ignitor	Red - Blue	90-120V		
SV	Black-Yellow	80-100V, 1.5-2.5kΩ		
Modulating Valve	Gray-Gray	DC6-16V (Low-High), 80-90Ω		
Convection Fan	Red - Black	56-75V 90-180Ω	56-94V 90-180Ω	
Pressure Sensor	Red - White	DC3 - 7V		
Transformer	-	Same as 431WTA	Same as 556WTA	

# Wire Diagram

RHFE-433RWTA  
RHFE-558RWTA

MARK	PART NAME	MARK	PART NAME
MS	MAIN SWITCH	OH.TH	OVER HEAT THERMISTOR
R.TH	THERMISTOR	OHS1, 2, 3	OVER HEAT SWITCH 1, 2, 3
TF	THERMAL FUSE	FM	CONVECTION FAN MOTOR
F	FUSE	SP	SPARKER
ER	ELECTRODE	SV1, 2	MAIN SOLENOID VALVE 1, 2
POV	MODULATING SOLENOID VALVE	BL	COMBUSTION FAN MOTOR
TR	TRANSFORMER	PS	PRESSURE SENSOR
FR	FLAME ROD		

CODE	COLOR
bk	black
bl	blue
gr	green
gr/y	green/yellow
r	red
w	white
y	yellow
gy	gray
or	orange

## WIRING DIAGRAM

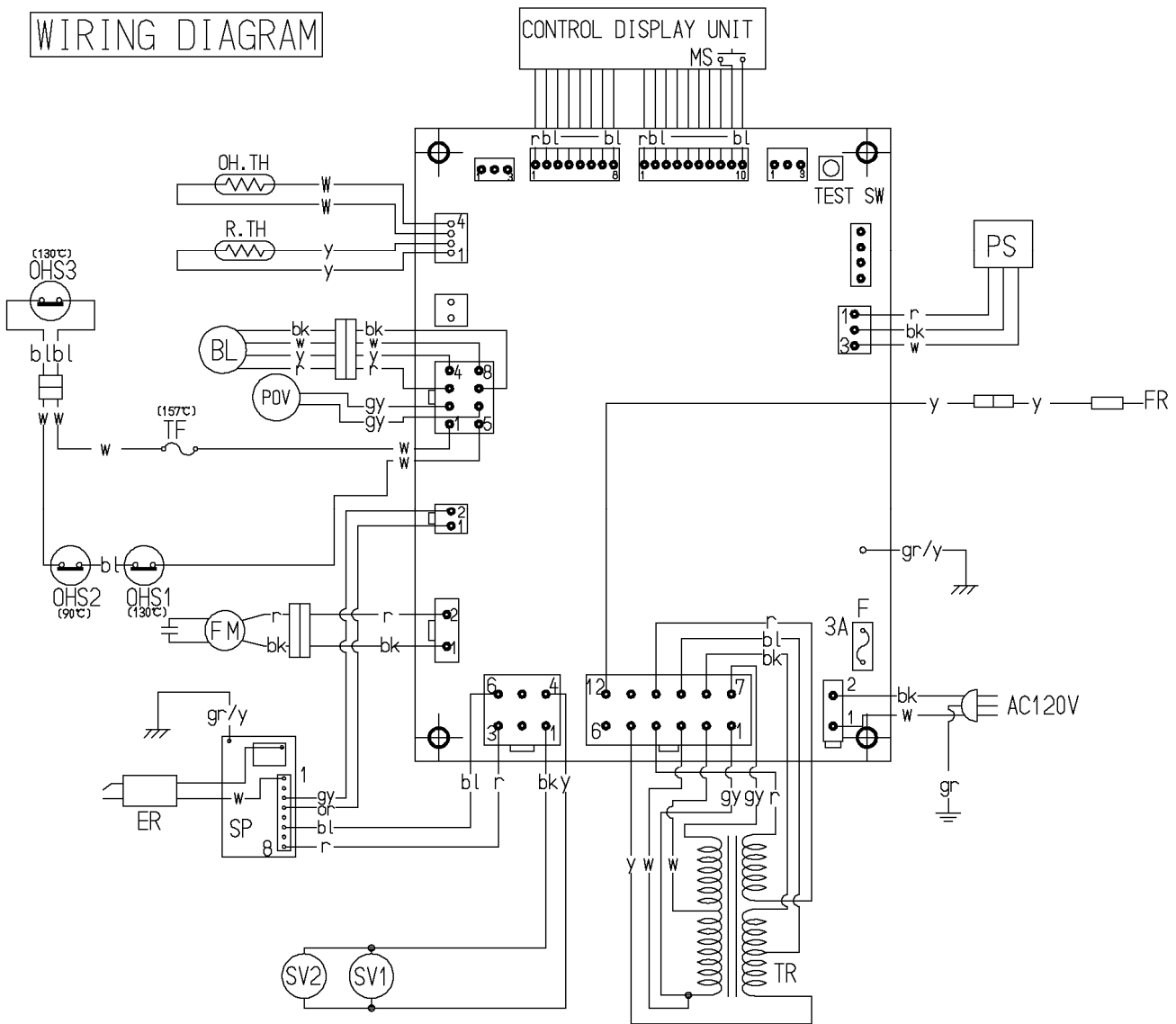

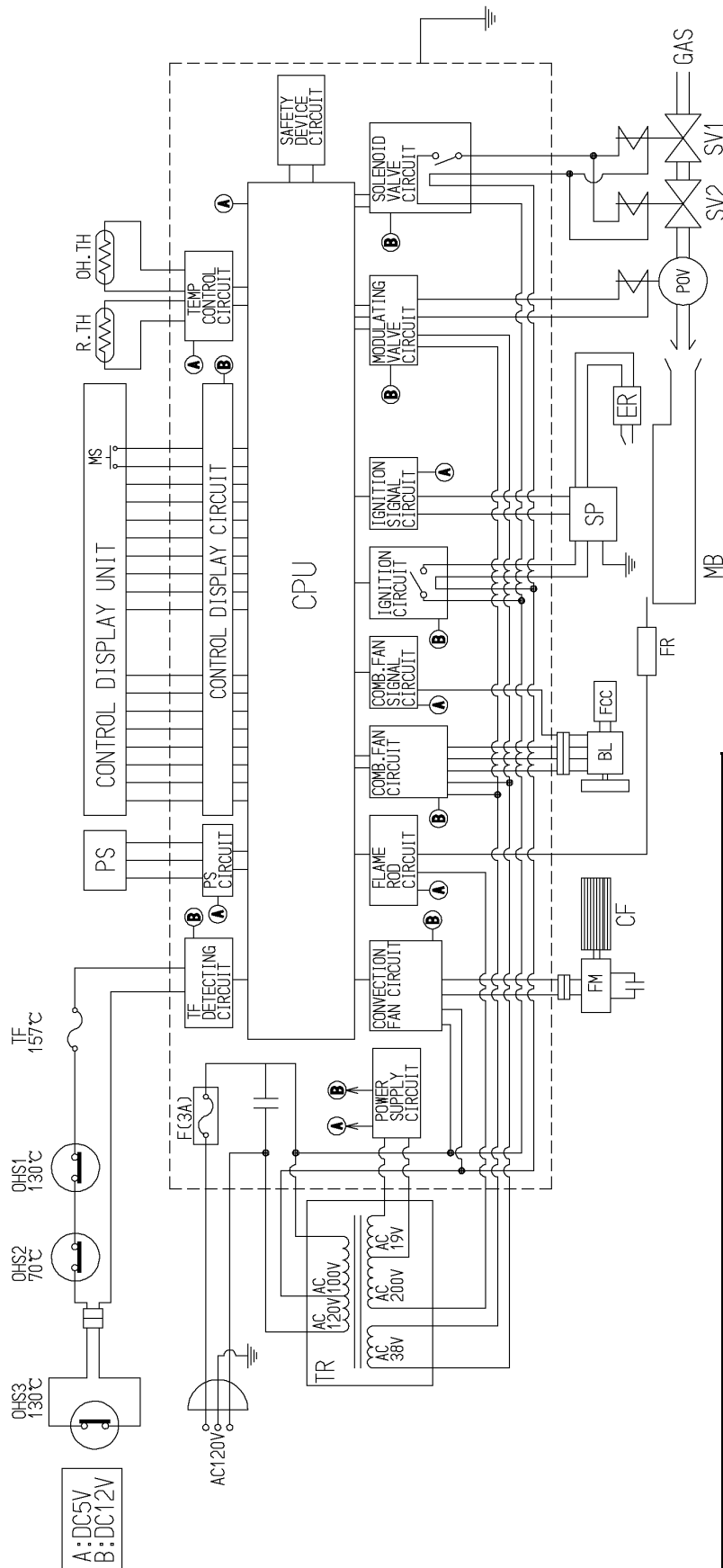

MARK	PART NAME	MARK	PART NAME
MS	MAIN SWITCH	OH.TH	OVER HEAT THERMISTOR
R.TH	THERMISTOR	OHS1, 2, 3	OVER HEAT SWITCH 1, 2, 3
TF	THERMAL FUSE	FM	CONVECTION FAN MOTOR
F	FUSE	SP	SPARKER
ER	ELECTRODE	SV1, 2	MAIN SOLENOID VALVE 1, 2
POV	MODULATING SOLENOID VALVE	BL	COMBUSTION FAN MOTOR
TR	TRANSFORMER	FCC	FAN CONTROL CIRCUIT
FR	FLAME ROD	MB	MAIN BURNER
PS	PRESSURE SENSOR	CPU	CENTRAL PROCESSING UNIT
CF	CONVECTION FAN		

Part	Wire	434FTA	559FTA	
Control Panel	Red - Blue	DC0-5V (Pulsed voltage) Resistance is infinity, but the current flows when the switch is pushed.		
	Blue - Blue			
OHS.	White - White	Below DC 1V, Below 2Ω		
	Blue - White (OHS1)			
	Blue - White (OHS2)			
TF	White - White (TF)			
O.H. TH	White - White	0.87-482kΩ, (<0.87kΩ:Short, >482kΩ:Open)		
	Temperature	32°F (0°C):214kΩ, 68°F (20°C):78kΩ, 122°F (50°C):21kΩ 176°F (80°C):7.3kΩ, 212°F (100°C):3.6kΩ, 135°F (275°C):1.5kΩ		
	White - White (Filter sign)	Low	Flashes below 6.83kΩ	Flashes below 6.40kΩ
		High	Flashes below 10.2kΩ	
	White - White (The TH operate)	High	Operates below 4.97kΩ	
Low		Operates below 7.29kΩ		
Room Thermistor	Yellow - Yellow	1.82-707kΩ, (<1.82kΩ:Short, >707kΩ:Open)		
	Temperature	32°F (0°C):113kΩ, 68°F (20°C):39kΩ, 86°F (30°C):24kΩ, 104°F (40°C):15kΩ		
FR	Yellow - Yellow	Below 0.1μA (During Stop)		
Combustion Fan (In case of short vent.)	White - Black		Below ignition revolution +2Hz	
	Ignition revolution	Initial	LP: 65Hz, NG: 70Hz	
		Re-attempt	LP: 65Hz, NG: 70Hz	
	Normal revolution	High	LP: 105Hz, NG: 105Hz	LP: 120Hz, NG: 120Hz
Low		LP: 70Hz, NG: 70Hz		
Combustion Fan (In case of long vent.)	White - Black		Same as short vent	
	Ignition revolution	Initial		
		Re-attempt		
	Normal revolution	High		
Low				
Ignitor	Red - Blue	90-120V		
SV	Black-White	80-100V, 1.5-2.5kΩ		
	Black-Yellow			
Modulating Valve	Red-White	DC2-15V (Low-High), 60-90Ω		
Convection Fan	Red - Black	50-110V, 70-160Ω		
Pressure Sensor	Red - White	DC3 - 7V		

Transformer	60Hz-120V
Gray - Gray	AC108-132V, 5-20Ω
White - White	AC95-120V, 5-20Ω
Red - Red	AC20-40V, 0.5-2.0Ω
Brown - Brown	AC10-30V, 1-5Ω
Black - Blue	AC10-30V, 1.0-3.0Ω
Black - Yellow	AC200-240V, 200-450Ω



# Wire Diagram

RHFE-434FTA  
RHFE-559FTA

MARK	PART NAME	MARK	PART NAME
MS	MAIN SWITCH	OH.TH	OVER HEAT THERMISTOR
R.TH	THERMISTOR	OHS1, 2, 3	OVER HEAT SWITCH 1, 2, 3
TF	THERMAL FUSE	FM	CONVECTION FAN MOTOR
F	FUSE	SP	SPARKER
ER	ELECTRODE	SV1, 2	MAIN SOLENOID VALVE 1, 2
POV	MODULATING SOLENOID VALVE	BL	COMBUSTION FAN MOTOR
TR	TRANSFORMER	PS	PRESSURE SENSOR
FR	FLAME ROD		

CODE	COLOR
bk	black
bl	blue
gr	green
gr/y	green/yellow
r	red
w	white
y	yellow
gy	gray
or	orange
br	brown

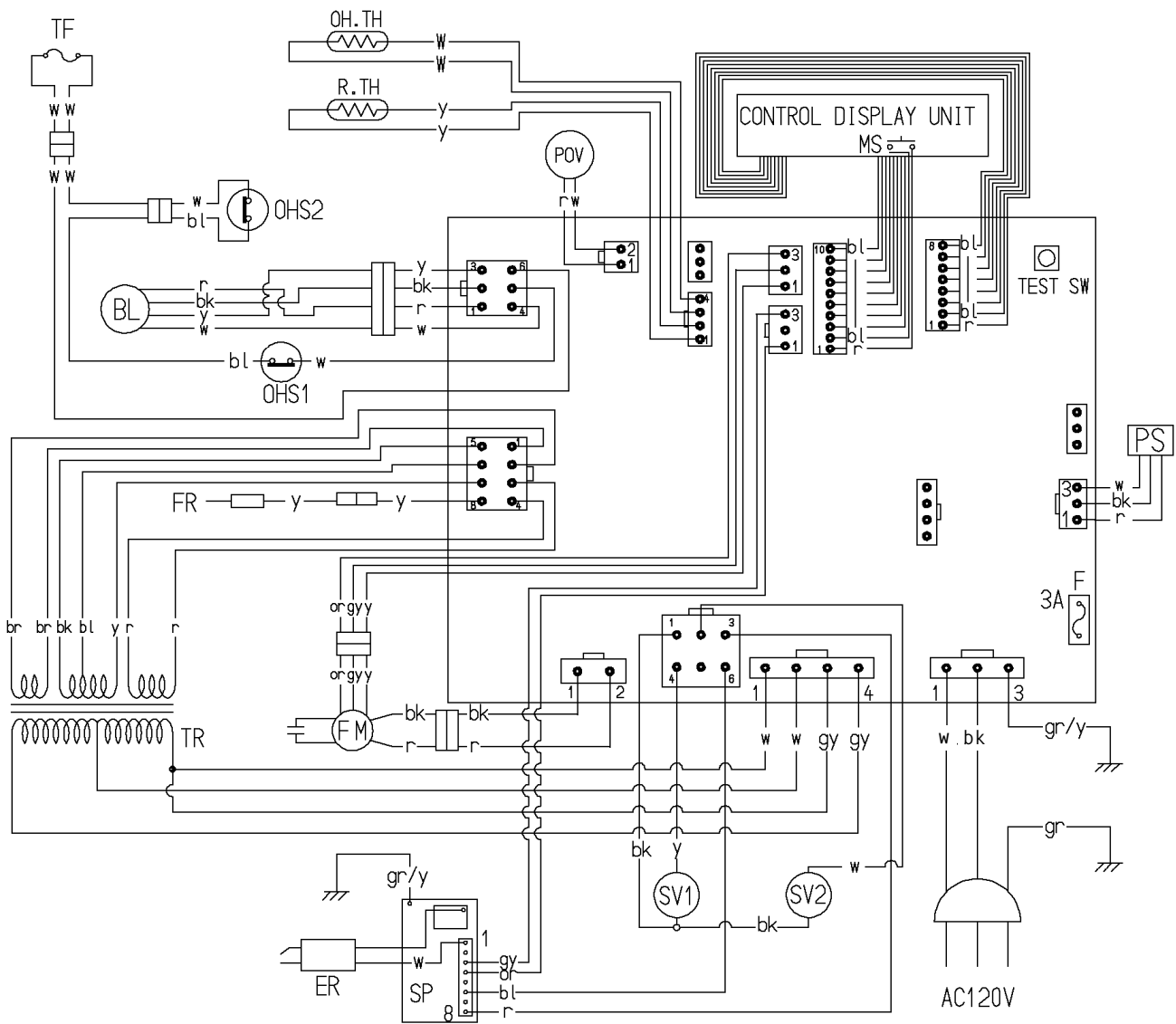

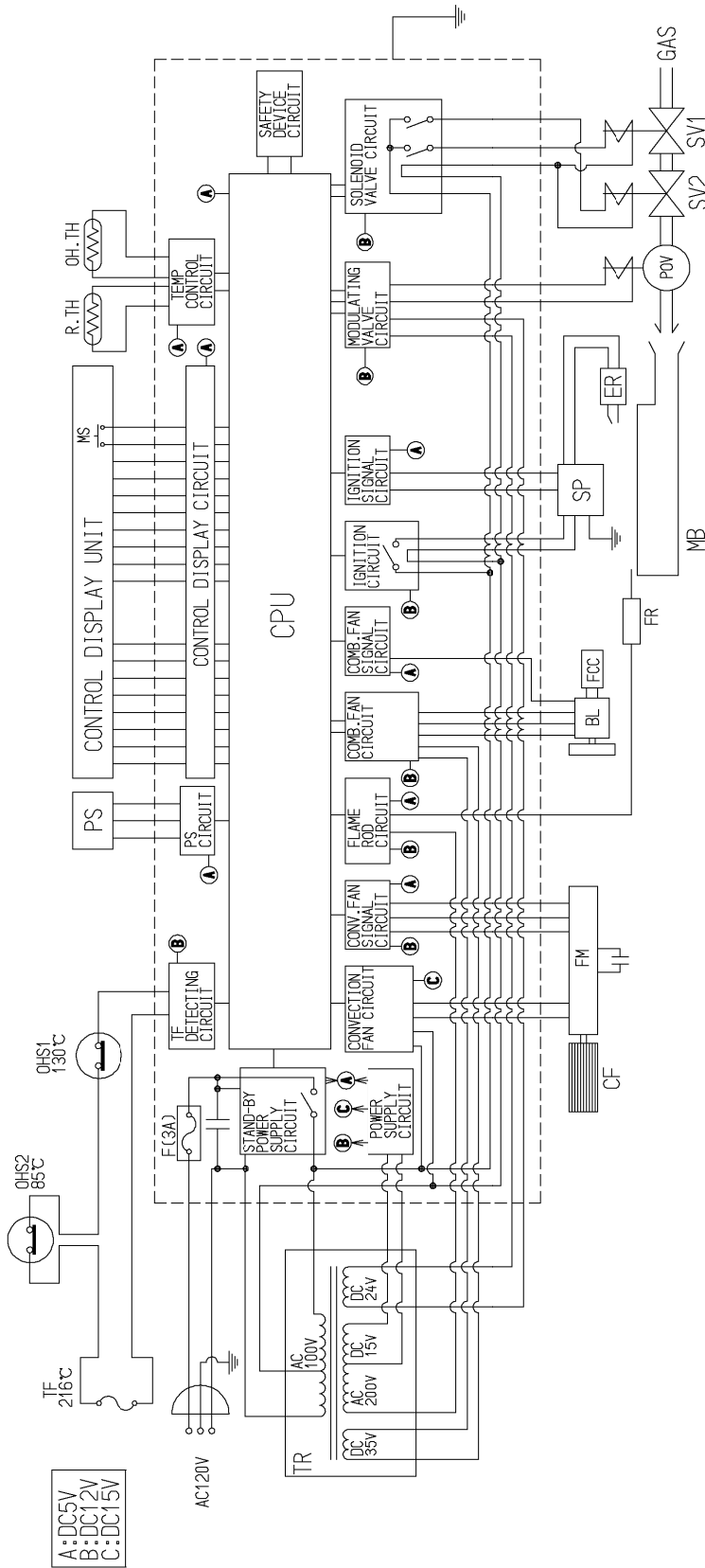

MARK	PART NAME	MARK	PART NAME
MS	MAIN SWITCH	OH.TH	OVER HEAT THERMISTOR
R.TH	THERMISTOR	OH.S1, 2	OVER HEAT SWITCH 1, 2
TF	THERMAL FUSE	FM	CONVECTION FAN MOTOR
F	FUSE	SP	SPARKER
ER	ELECTRODE	SV1, 2	MAIN SOLENOID VALVE 1, 2
POV	MODULATING SOLENOID VALVE	BL	COMBUSTION FAN MOTOR
TR	TRANSFORMER	FCC	FAN CONTROL CIRCUIT
FR	FLAME ROD	MB	MAIN BURNER
PS	PRESSURE SENSOR	CPU	CENTRAL PROCESSING UNIT
CF	CONVECTION FAN		

**⚠ WARNING**

There are a number of live tests that are required when fault finding this product. Extreme care should be used at all times to avoid contact with energized components inside the furnace.

You MUST be a qualified service person before proceeding with these test instructions.

Before checking resistance readings, turn off power source to unit and then isolate each item to be checked from the circuit by unplugging it.

When setting gas pressures on one of these units, please check the complete model number you are trouble-shooting. Gas pressures and dip switches can vary among models. Always check the rating plate for complete information and follow directions.

**(TR) Transformer:**

Read Voltage across:

WIRE COLOR	VOLTAGE	RESISTANCE READING
Red - Red	100 VAC primary side	38 - 44 ohms
Yellow - Yellow	220 VAC secondary side	1250 - 1400 ohms
White - White	15 VAC secondary side	1.9 - 2.3 ohms

**(SP) Sparker Board:**

Read voltage across:

Brown -----

85 - 95 VDC

Purple -----

Check from the white wire in the molex connector at the ignitor transformer to ground. You should read 1.5 - 1.8 VDC when the unit is trying to ignite.

**(SV1, SV2, SV3) Gas valve solenoids**

SV1 - Purple - Yellow	90 VDC Lo fire	1,200 - 1,800 ohms
SV2 - Purple - Peach	90 VDC Hi fire	1,200 - 1,800 ohms
SV3 - Purple - Yellow	90 VDC redundant coil	1,200 - 1,800 ohms

**(BL) Combustion Fan Motor:**

NOTE: If your meter does not have a hertz scale, please refer to voltage and resistance readings listed below. If you have a hertz scale, check the following items first. Hertz reading across black - white wires, pins 41

White - yellow = low speed	95 - 105 VAC	200 - 300 ohms
White - red = high speed		120 - 180 ohms

**(FM) Convection fan motor:**

White - blue = low speed		230 - 290 ohms
White - red = high speed		100 - 125 ohms

**(TR1) Transformer**

Black - White	110 - 125 primary side	16 - 21 ohms
Red - Black	98 - 105 secondary side	24 - 29 ohms

**(PS) Pressure switch:**

White - Ground Check from both white wires to ground to ensure circuit is complete.	9 - 12 VDC	In order to eliminate this switch as a cause of failure, shut the power off to the unit and jump out this switch. Restart unit. If it functions, replace air pressure switch.
--	------------	---

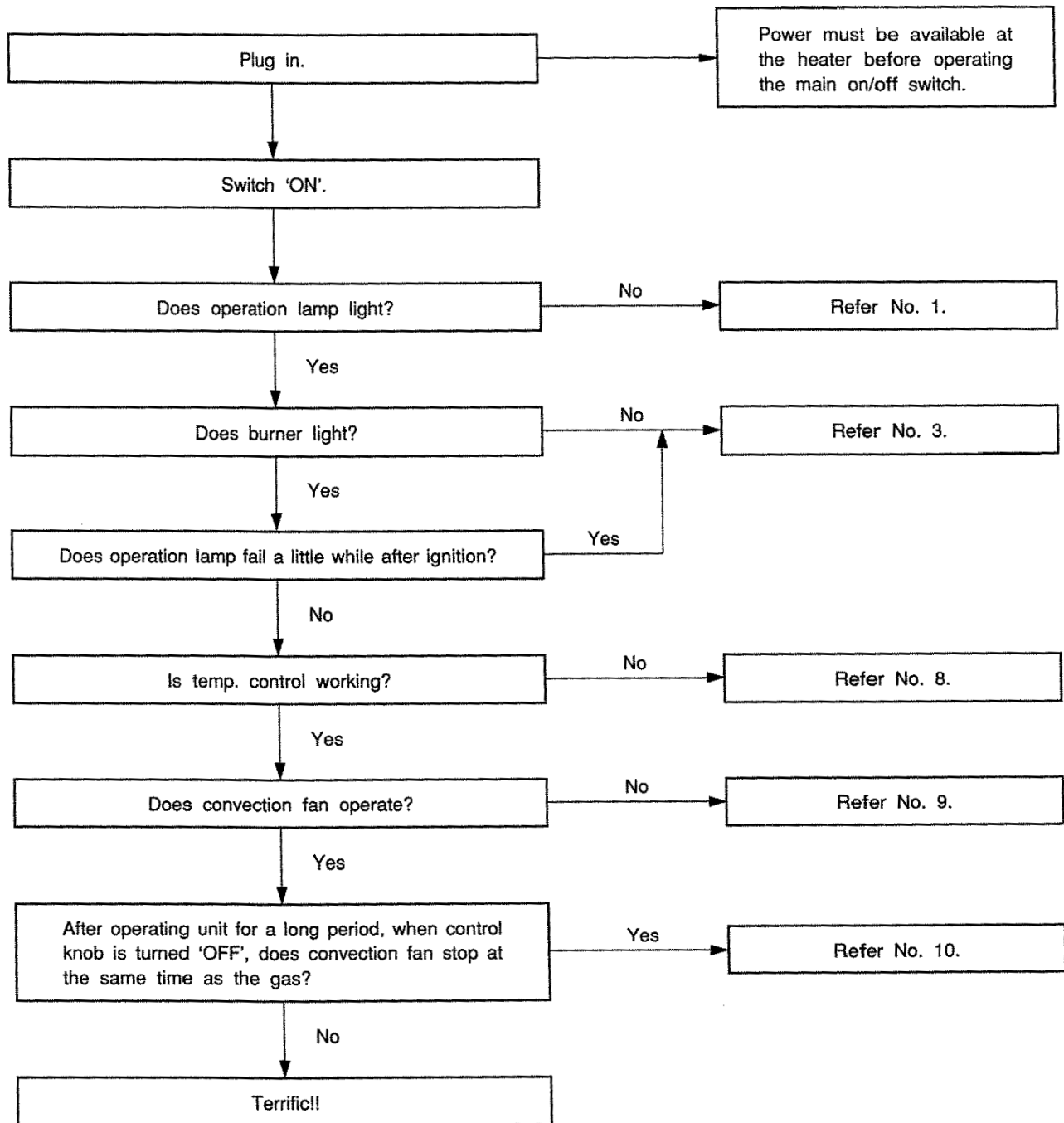

**IMPORTANT SAFETY NOTE:**

**A NUMBER OF ENERGIZED (LIVE) TESTS ARE REQUIRED TO BE DONE IN THE FAULT FINDING PROCEDURES. EXTREME CARE WILL BE NEEDED AT ALL TIMES.**

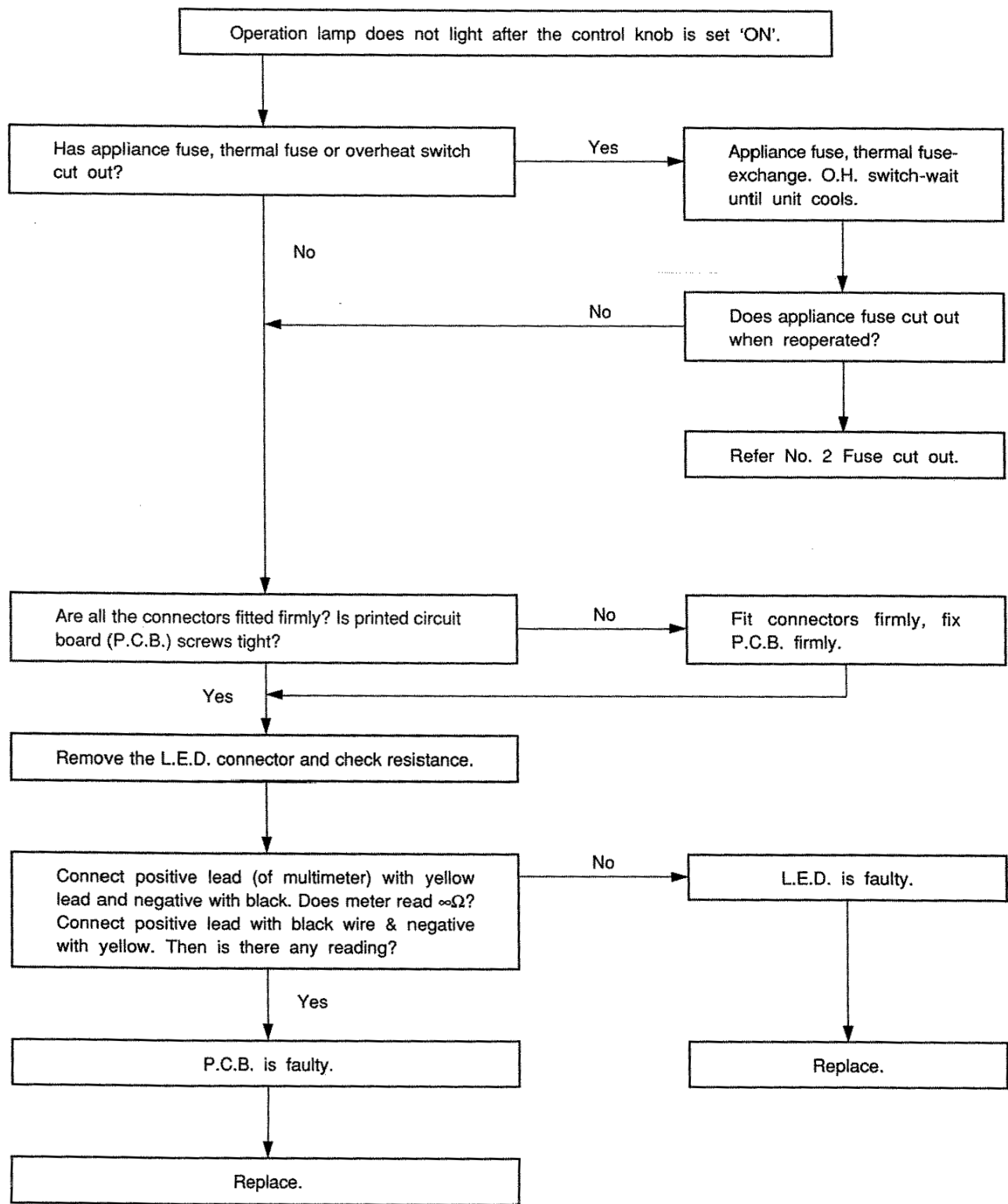

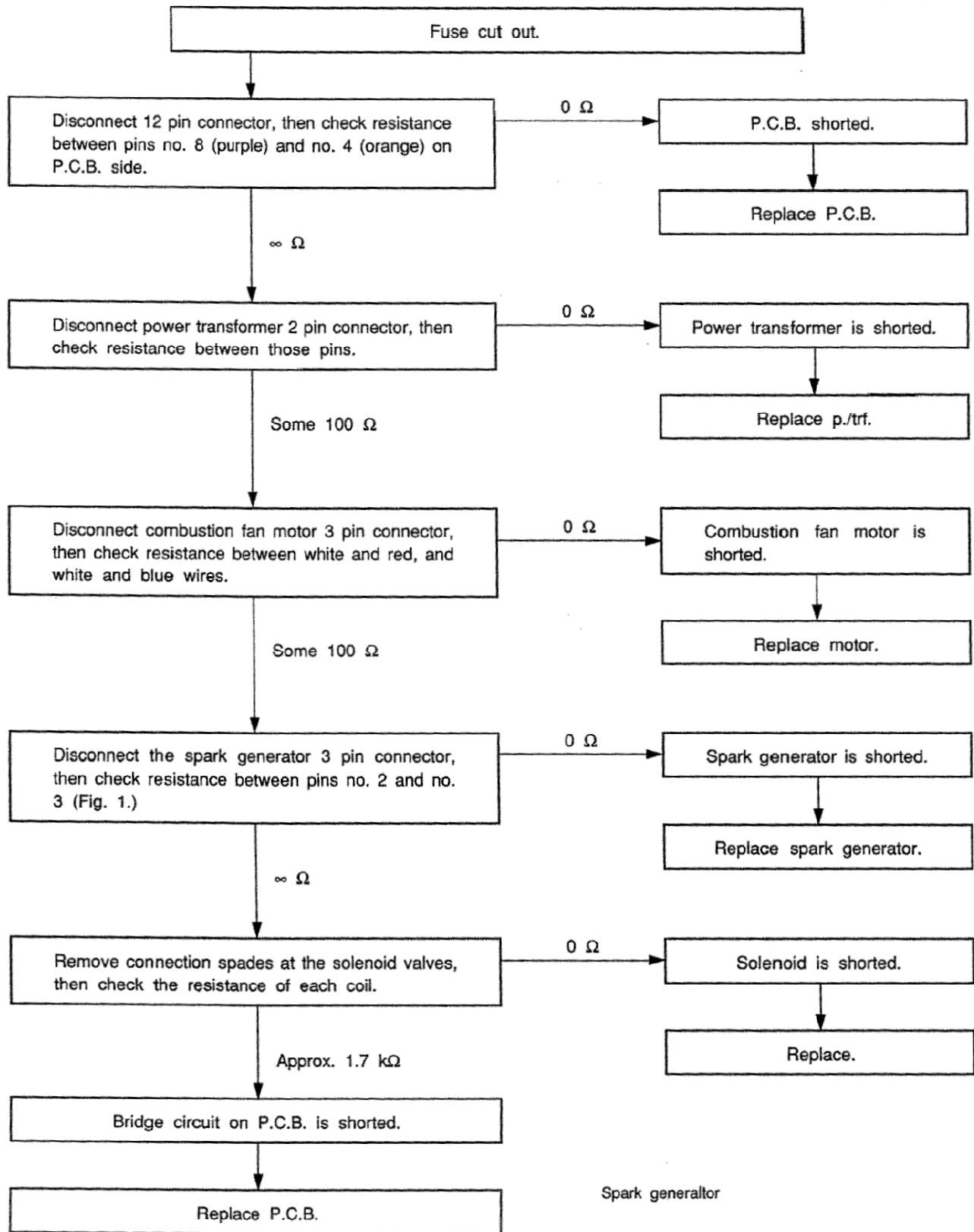

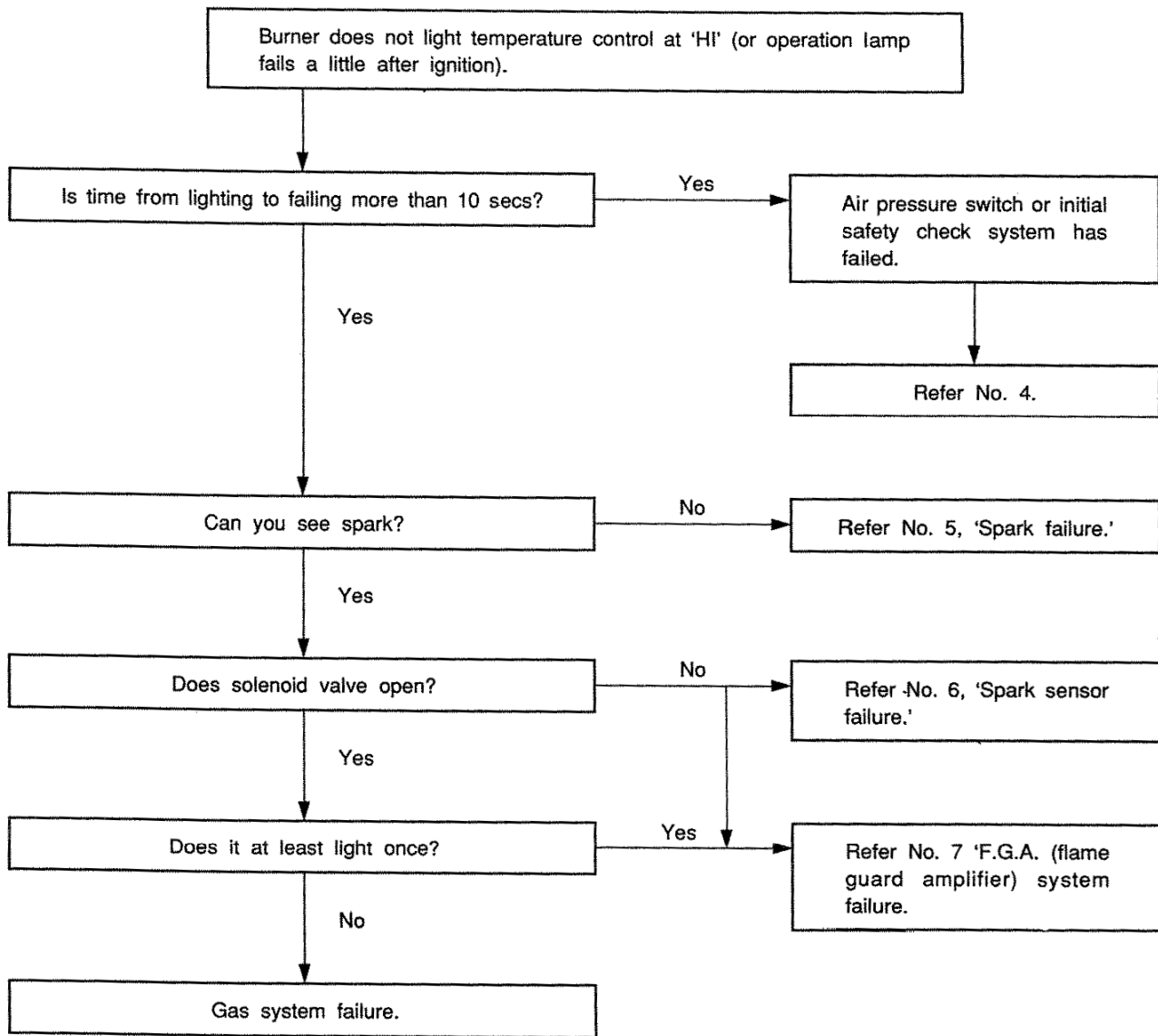

NOTE: Ignition sequence is repeated once again if the initial sequence fails to ignite burner.



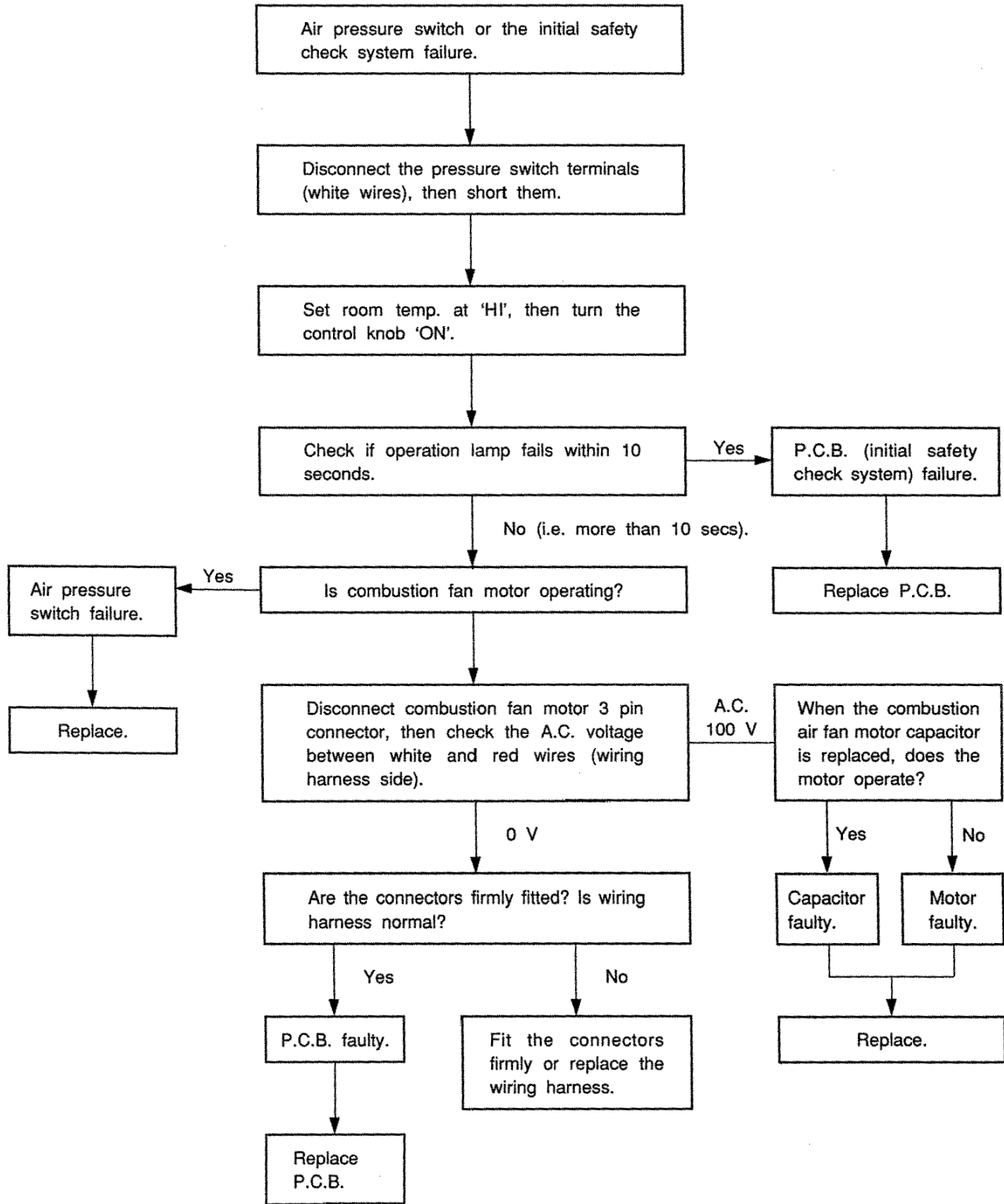

NOTE: When the ambient temperature is extremely low, it may take considerably longer for the air pressure switch to operate.

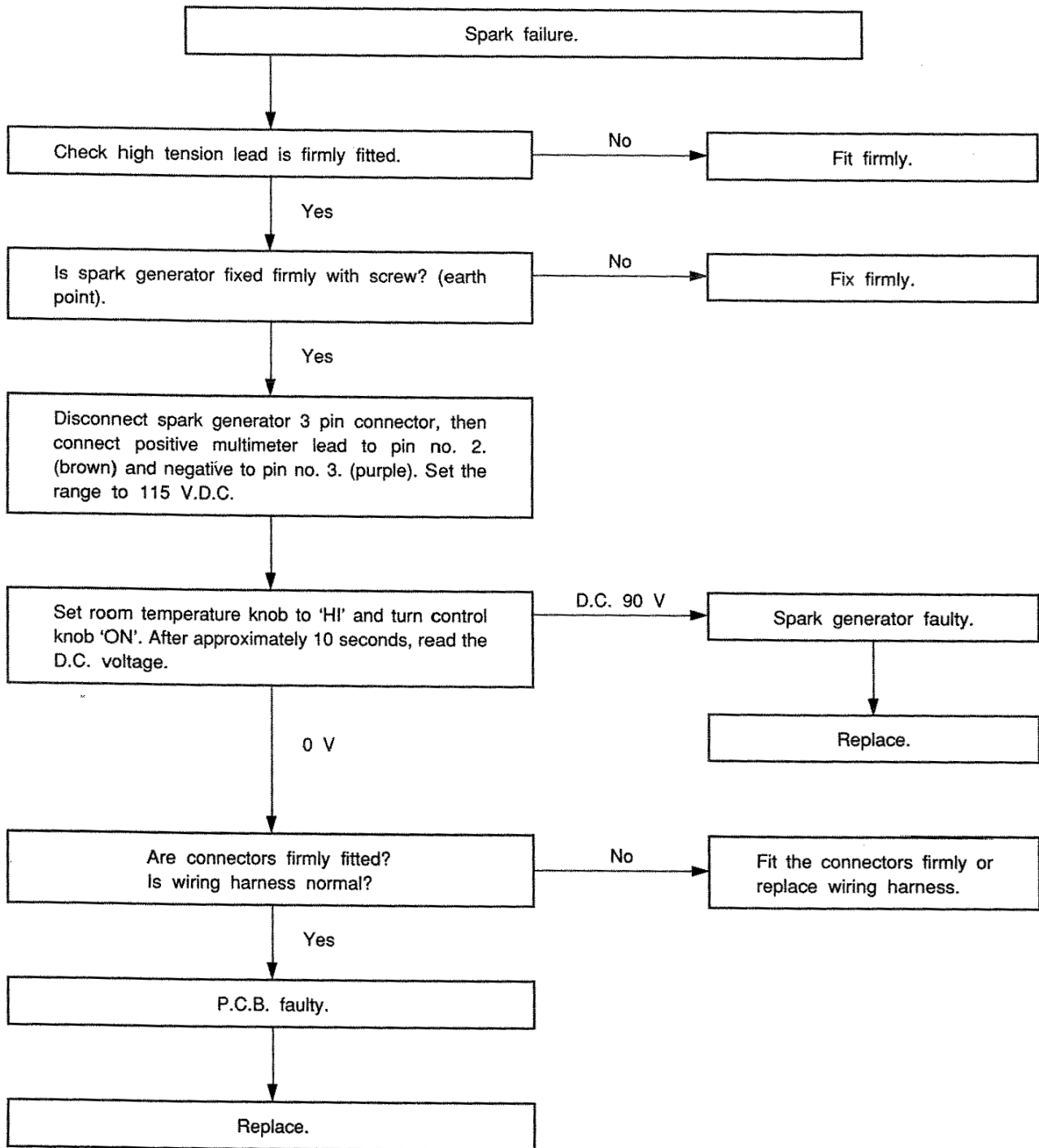

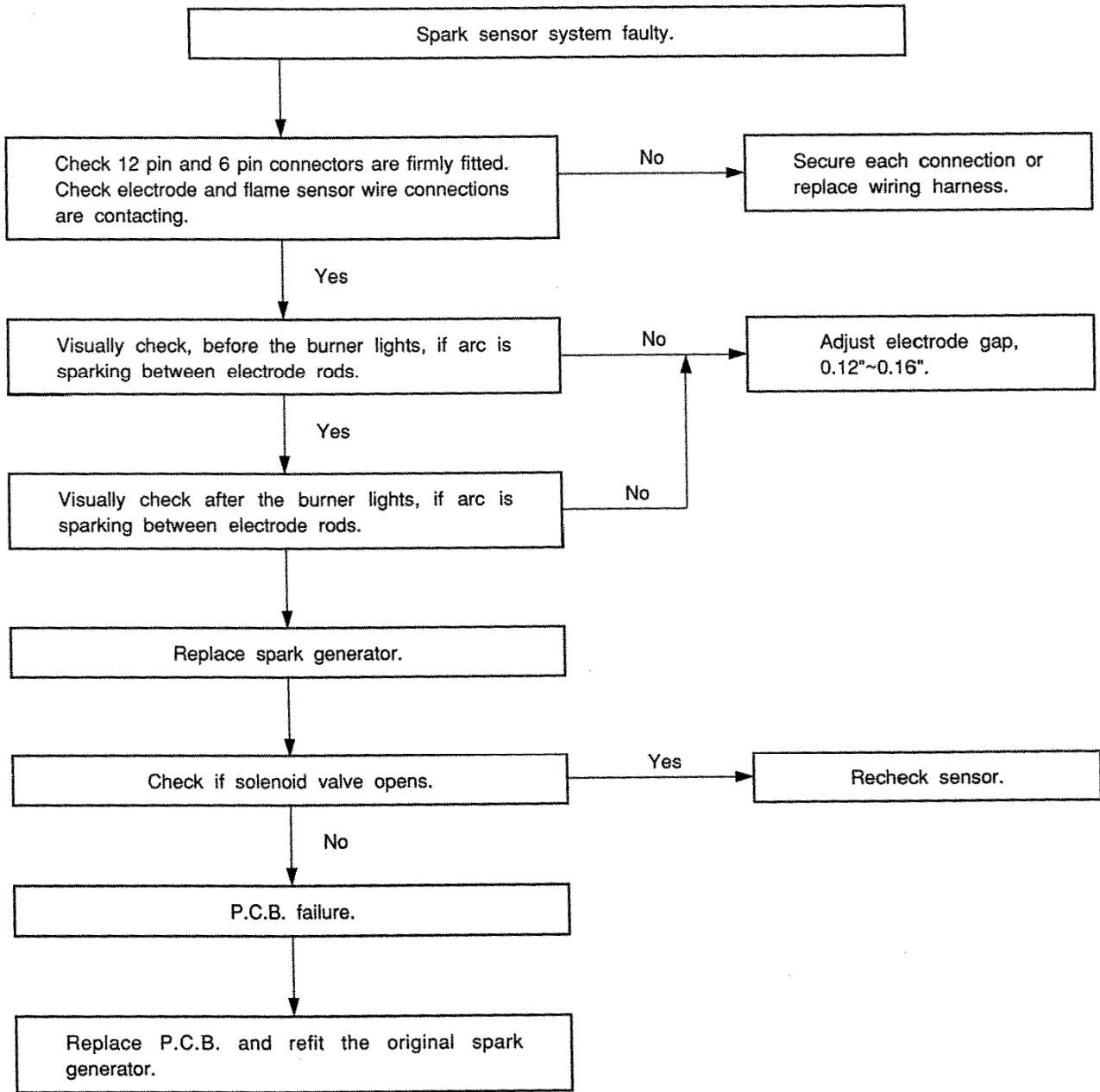

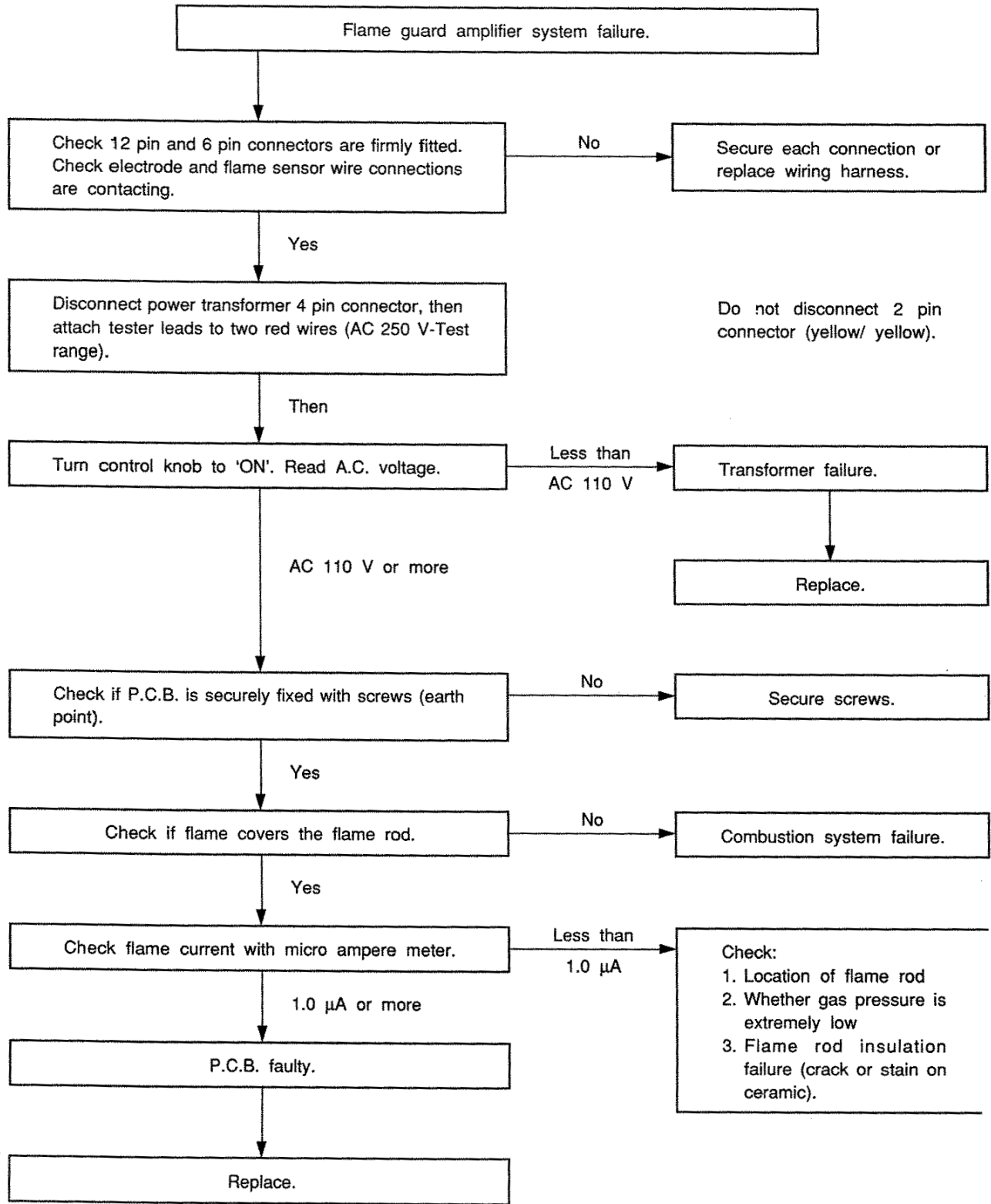

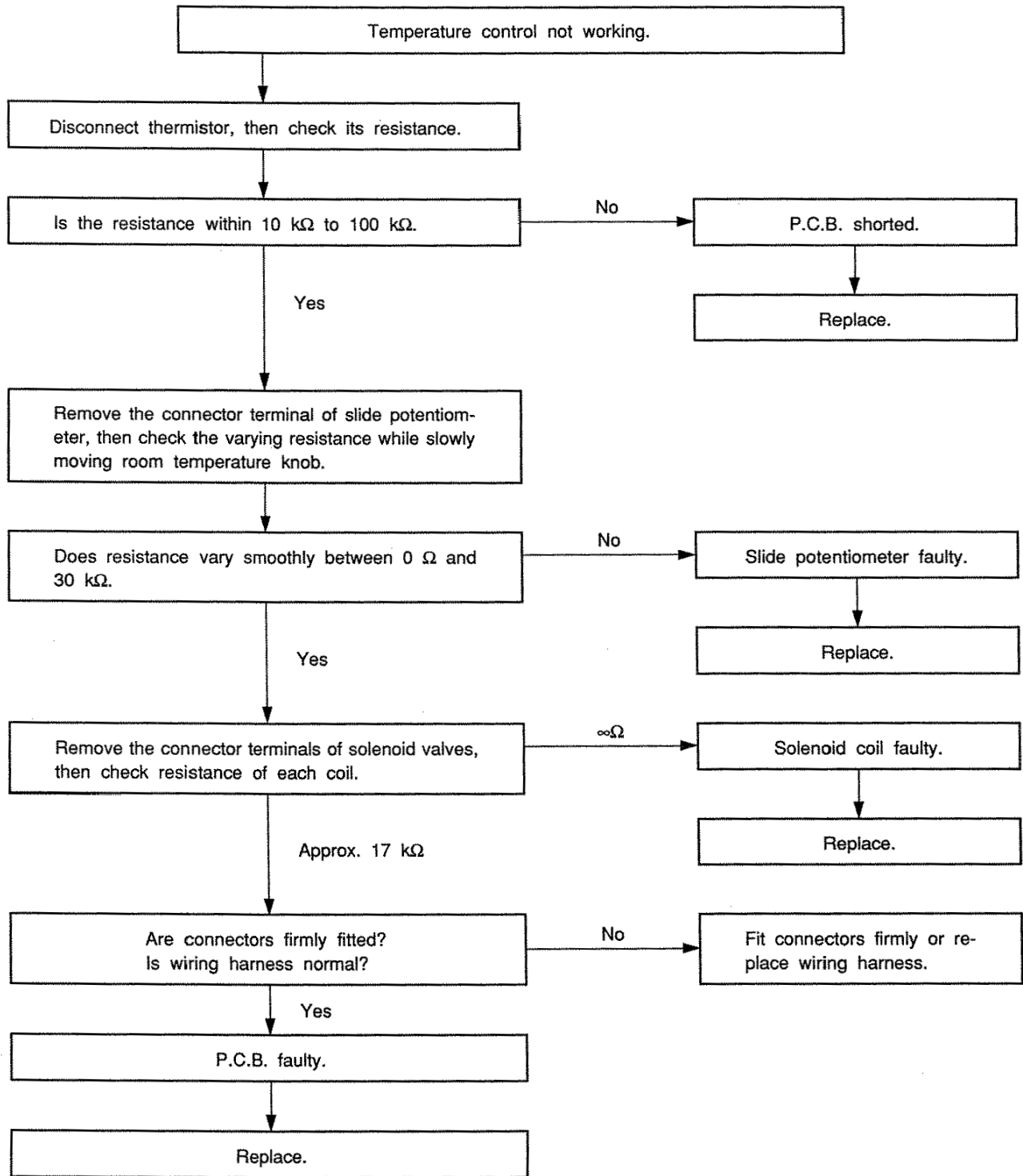

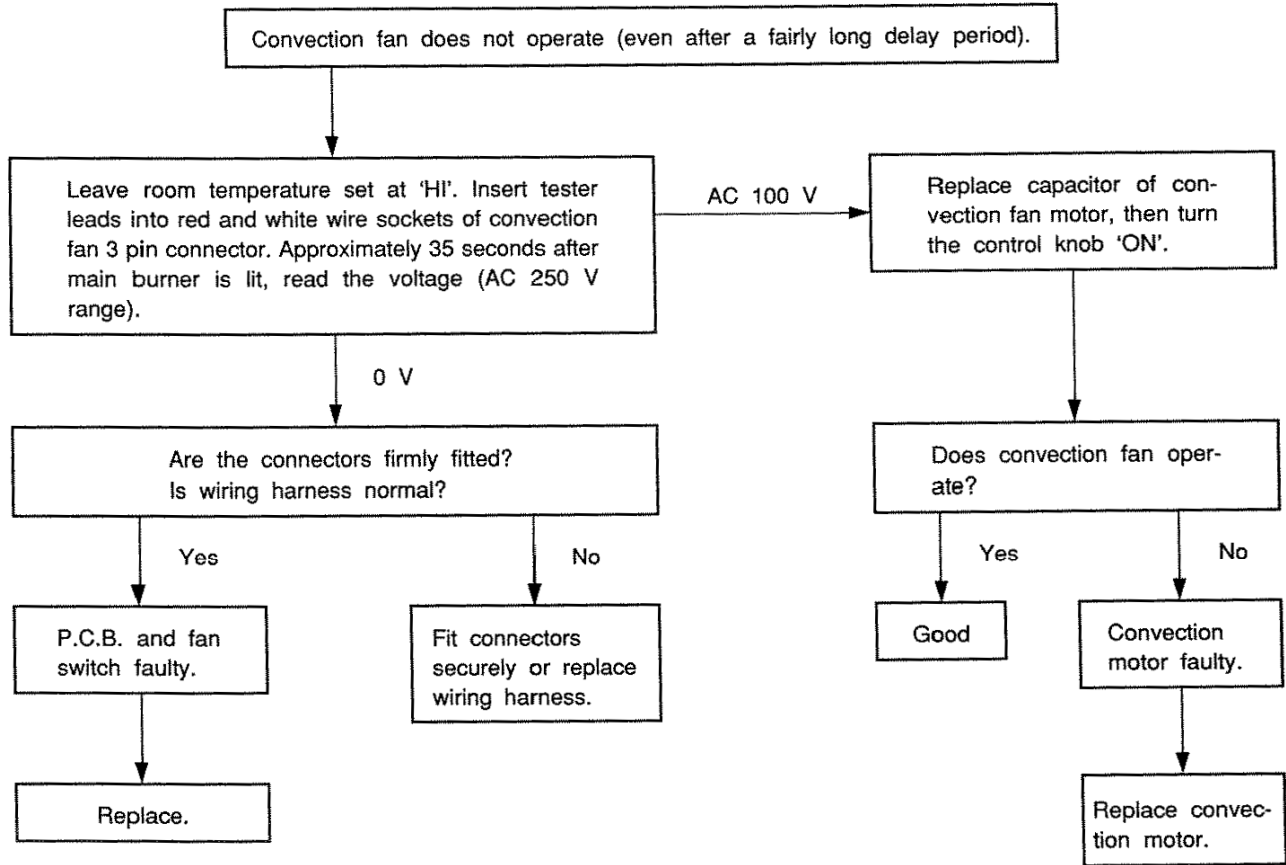

**No. 10**

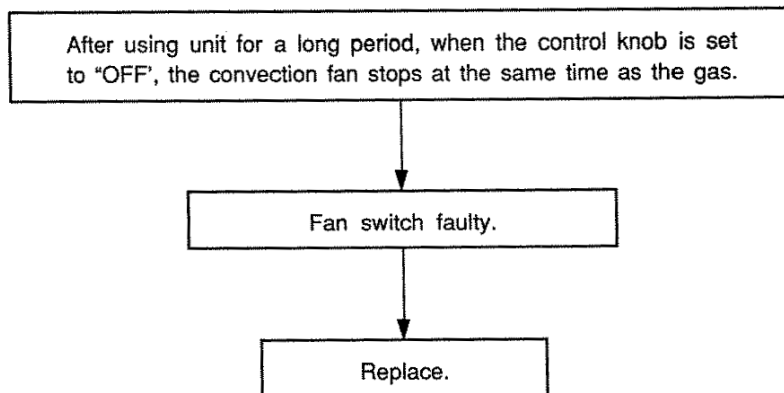

NOTE: After the main burner has lit, if the main switch is turned to 'OFF', in the period when the fan is operated by the 32 seconds delay timer (before the thermal switch closes), the fan will stop immediately.

**IMPORTANT SAFETY NOTE:**

A NUMBER OF ENERGIZED (LIVE) TESTS ARE REQUIRED TO BE DONE IN THE FAULT FINDING PROCEDURES. EXTREME CARE WILL BE NEEDED AT ALL TIMES.



**⚠ WARNING**

There are a number of live tests that are required when fault finding this product. Extreme care should be used at all times to avoid contact with energized components inside the furnace.

You **MUST** be a qualified service person before proceeding with these test instructions.

Before checking resistance readings, turn off power source to unit and then isolate each item to be checked from the circuit by unplugging it.

When setting gas pressures on one of these units, please check the complete model number you are trouble-shooting. Gas pressures and dip switches can vary among models. Always check the rating plate for complete information and follow directions.

(TR2) Transformer:

Read voltage across:		Read resistance	Pin #'s
Red - Red	98 - 105 VAC	39 - 44 ohms	N/A
Yellow - Yellow	208 - 224 VAC	1,325 - 1,390 ohms	14 - 17
White - White	10 - 15 VAC	2.0 - 2.5 ohms	15 - 16

(SP) Sparker:

+ Red -----  
 85 - 95 VDC    N/A    Pin # 28 - 29  
 - White -----

(SV1, SV2, SV3) Gas solenoids:

SV1 - White ~ Blue (redundant)	85 - 90 VDC	1,400 - 1,800 ohms	29 - 30
SV2 - White ~ Blue (lo fire)	85 - 90 VDC	1,200 - 1,600 ohms	29 - 30
SV3 - Black ~ White (hi fire)	85 - 90 VDC	1,200 - 1,600 ohms	29 - 31

(BL) Combustion fan motor:

White - Orange = lo speed	95 - 105 VAC	200 - 300 ohms	18 - 20
White - Black = hi speed	95 - 105 VAC	120 - 180 ohms	18 - 21
Capacitor	220 VAC (3.5 µF)		
White - Red = lo speed	95 - 105 VAC	100 - 140 ohms	18 - 26
White - black = hi speed	95 - 105 VAC	42 - 62 ohms	18 - 25



(TR1) Transformer:

Black - White = primary	110 - 125 VAC	19 - 20 ohms	n/a
Grey - Grey = secondary	95 - 105 VAC	19 - 20 ohms	n/a
White - Ground	9 - 12 VDC	n/a	4 - 5

Check from both white to ground to ensure circuit is complete.

In order to eliminate this switch as a cause of failure, shut the power off to the unit and jump out this switch. Resart unit. If it functions, remove jumper, and replace air pressure switch.

Room Temperature Thermistor

Yellow - Yellow		10-100 kΩ	
-----------------	--	-----------	--

Flame Rod

0.8 μA or greater
-------------------

Slide Temperature Control

White to Black		0-30 kΩ	
White to Red		0-30 kΩ	

The resistance will change when the slide is moved.

**CAUTION: WHERE # APPEARS DISCONNECT ELECTRICAL PLUG BEFORE PROCEEDING WITH TEST.**

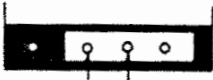
NATURE OF FAULT	EXAMINATION POINT	DIAGNOSTIC POINT	VALUES	ACTION
<b>TABLE A</b> The ON indicator does not glow after having switched the appliance ON. Due to Power Failure Safety Circuit, the appliance will not operate again until the ON/OFF button is pushed off, then on again.	#1 Is the electrical plug in the wall socket firmly? Is the voltage normal?	• Check the electrical connection and voltage.	120V ± 15%	YES → Go to 2 NO → Rectify
	#2 Is the O.H.S. in the OFF position?	• Check the O.H.S. continuity.	Approx. 0 Ω → normal	YES → Go to 3 NO → Replace O.H.S.
	#3 Has the thermal fuse blown?	• Check the continuity through the fuse.	Approx. 0 Ω → normal	YES → Go to 4 NO → Replace thermal fuse
	#4 Is the movement of the ON/OFF button normal?	• With the appliance OFF, remove the connector and check the continuity of the blue - brown, brown - red wires.	Blue - Brown → Approx. 0 Ω is O.K. Brown - Red → Approx. ∞ Ω is O.K.	YES → Go to 5 NO → Replace ON/OFF switch
	#5 Is the transformer O.K.? (TR 2)	• Check the resistance of the transformer.	Red - Red Approx. 45 ~ 70 Ω? White - White Approx. 1.8 ~ 2.5 Ω?	YES → Go to 6 NO → Replace transformer
	#6 Is the electrical fuse blown?	• Check continuity of fuse.	Approx. 3.0 ~ 6.0 Ω?	YES → Go to 7 NO → See table B
	#7 Is the LED P.C.B. O.K.?	• Check the voltage of the white - yellow indicator connecting wire. <b>Confirmation must be made during the first 30 seconds after switching ON.</b>	Approx. 14 ~ 23 Volts	YES → Replace LED P.C.B. NO → Replace the main P.C.B.
<b>TABLE B</b> The electrical fuse blows when the appliance is turned ON.	#1 Is the transformer O.K.? (TR 2)	• Check the resistance of the transformer.	White - White → 1.8 ~ 2.5 Ω Red - Red → 45 ~ 70 Ω	YES → Go to 2 NO → Replace transformer
	#2 Is the black spark generator O.K.?	• Check the resistance between the points shown here. 	Is the value ∞ Ω?	YES → Go to 3 NO → Replace sparker
	#3 Is combustion fan motor operating correctly?	• Check the resistance of the combustion fan motor.	White - Orange → 200 ~ 300 Ω? White - Black → 120 ~ 180 Ω?	YES → Go to 4 NO → Replace combustion fan motor.
	#4 Are the solenoids operating correctly?	• Release the pin connectors from each solenoid valve and check the resistance between both solenoid terminals. <b>Warning: Do not pull on the wires.</b>	1.3 kΩ ~ 1.8 kΩ	YES → Go to 5 NO → Replace solenoids
	#5 Is the convection fan motor operating correctly?	• Release the convection fan motor pin connector. Check the resistance.	White - Red → 100 ~ 140 Ω? White - Black → 50 ~ 70 Ω?	YES → Replace the P.C.B. NO → Replace convection fan motor.

NATURE OF FAULT	EXAMINATION POINT	DIAGNOSTIC POINT	VALUES	ACTION
<b>TABLE C</b> 10 seconds after switching ON, the ON indicator goes out.  <b>NOTE:</b> The combustion fan motor does not rotate during this interval.	#1 Is the combustion fan motor operating correctly?	<ul style="list-style-type: none"> <li>Check the AC voltage at the combustion fan motor W - O pin connectors within the 10 seconds, before the ON indicator goes out.</li> </ul>	AC 90 ~ 110 Volts	YES → Go to 2 NO → Replace combustion fan motor
	#2 Is the combustion fan motor capacitor O.K.?	<ul style="list-style-type: none"> <li>Alternate the tester between the ⊖ &amp; ⊕ terminals of the capacitor and check the resistance.</li> </ul>	Does the tester oscillate for a moment, then return to ∞ Ω?	YES → Go to 3 NO → Replace the capacitor
	#3 Is the P.C.B. O.K.?	<ul style="list-style-type: none"> <li>Check the AC voltage at the combustion fan motor W - O pin connectors within the 10 seconds, before the ON indicator goes out.</li> </ul>	AC 90 ~ 110 Volts	YES → Confirm combustion fan motor connector contact. NO → Replace the P.C.B.
<b>TABLE D</b> During the first 10 seconds after switching the appliance ON the combustion fan operates twice from HI to LOW.	1 Is the sparker operating correctly?	<ul style="list-style-type: none"> <li>Check the DC voltage at the white - red connector.</li> </ul> <b>NOTE:</b> There will only be voltage when the combustion fan is running on LOW.	DC 80 ~ 100 Volts	YES → Replace the sparker NO → Replace the P.C.B.
<b>TABLE E</b> There is no spark and the combustion indicator does not glow.	1 Check that the high tension cord and spark lead are firmly in position.	<ul style="list-style-type: none"> <li>Disconnect power, check and confirm the connections by hand.</li> </ul>	Tight - no insulation leaks?	YES → Go to 2 NO → Rectify the connections.
	#2 Are the solenoids operating correctly?	<ul style="list-style-type: none"> <li>Release the pin connectors from each solenoid valve and check the resistance between both solenoid terminals. <b>Warning: Do not pull on the wires.</b></li> </ul>	1.3 kΩ ~ 1.8 kΩ	YES → Go to 3 NO → Replace the solenoids
	#3 Is the transformer O.K.? (TR 2)	<ul style="list-style-type: none"> <li>Release the transformer pin connector and check the resistance of the yellow - yellow wires.</li> </ul>	390 ~ 550 Ω	YES → Go to 4 NO → Replace the transformer
	4 Is the LOW burner flame rod clean? Does the LOW burner ignite?	<ul style="list-style-type: none"> <li>Confirm the flame rod current. Is lead attached correctly? Is the insulation broken?</li> </ul>	Yellow - Fr1 Above 0.8 μA.	YES → Check Symptoms again. NO → Replace the flame rod
<b>TABLE F</b> The appliance ignites on the LOW burner, but goes to lockout after several seconds.	1 Does SV <sub>1</sub> SV <sub>2</sub> open?	<ul style="list-style-type: none"> <li>Release the pin connectors from each solenoid valve and check the resistance between solenoid terminals. <b>Warning: Do not pull on the wires.</b></li> </ul>	Is there an opening sound?	YES → Go to 2 NO → Go to 3
			#1.3 kΩ ~ 1.8 kΩ	YES → Go to 2 NO → Replace solenoids
	2 Are the injectors, gas pressure, damper, gas pipe sizing and gas filter all clean?	<ul style="list-style-type: none"> <li>Are there any blockages in any of these areas?</li> </ul>	Is everything correct?	YES → Go to 4. NO → Rectify
	3 Is the P.C.B. O.K.?	<ul style="list-style-type: none"> <li>Confirm DC voltage of SV<sub>1</sub> SV<sub>2</sub>. White - Black wires.</li> </ul>	DC 80 ~ 100 Volts	YES → Replace solenoids NO → Replace P.C.B.
4 Is the area surrounding the LOW burner flame rod clear and O.K.?	<ul style="list-style-type: none"> <li>Confirm the flame rod current.</li> </ul>	Yellow - Fr2 Above 0.8 μA.	YES → Check symptoms again NO → Replace the flame rod	

NATURE OF FAULT	EXAMINATION POINT	DIAGNOSTIC POINT	VALUES	ACTION
<b>TABLE G</b> The thermostat control does not modulate.	#1 Is the thermistor O.K.?	<ul style="list-style-type: none"> <li>Release the thermistor connector and check the thermistor resistance.</li> </ul>	41°F = 5°C = 91 kΩ 50°F = 10°C = 65 kΩ 68°F = 20°C = 39 kΩ 86°F = 30°C = 23 kΩ	YES → Go to 2 NO → Replace the thermistor
	#2 Is the thermostat slide control operating correctly?	<ul style="list-style-type: none"> <li>Release the thermostat control pin connectors, and confirm the resistance of the white - red &amp; white - black wires.</li> </ul>	Does it vary from 0Ω ~ 30 kΩ	YES → Replace the P.C.B. NO → Replace the thermostat slide control
<b>TABLE H</b> The flame goes out during normal operation. [Flame failure] Check the air filter and gas pressure.	1 Are the convection fan revolutions correct? [If it's low then the O.H.S. will be activated]. HI → above 700 rpm. LOW → above 400 rpm.	<ul style="list-style-type: none"> <li>Confirm the voltage at the convection fan motor connectors.                              HI → White - Black                              LOW → White - Red</li> </ul>	AC 90 ~ 110 Volts	YES → Go to 2 NO → Replace the P.C.B.
		<ul style="list-style-type: none"> <li>Release the convection fan motor pin connector. Check the resistance of the white - red, white - black wires.</li> </ul>	White - Red → 100 ~ 140 Ω White - Black → 50 ~ 70 Ω	YES → Go to 2 NO → Replace the motor
		<ul style="list-style-type: none"> <li>Alternate the tester between the ⊖ &amp; ⊕ terminals of the convection fan motor capacitor and check the resistance.</li> </ul>	Does the tester oscillate for a moment, then return to ∞ Ω?	YES → Go to 2 NO → Replace the capacitor
	2 Are the O.H.S. No. 1, No. 2 operating normally?	<ul style="list-style-type: none"> <li>Check the temperature marked on the O.H.S.</li> </ul>	No. 1 = A 65°C No. 2 = A 130°C	YES → Go to 3 NO → Replace the O.H.S.
	#3 Is the air pressure switch operating correctly?	<ul style="list-style-type: none"> <li>Check the air pressure switch is de-activated when the combustion fan goes off.</li> </ul>	Is the value ∞ Ω	YES → Check symptoms again NO → Replace the air pressure switch
<b>TABLE I</b> Operation of the appliance is normal but the combustion indicator does not glow.	1 Is the combustion indicator blown?	<ul style="list-style-type: none"> <li>Release the white - red combustion indicator connector and confirm the DC voltage.</li> </ul>	DC 14 ~ 23 Volts	YES → Replace the indicator P.C.B. NO → Replace the P.C.B.

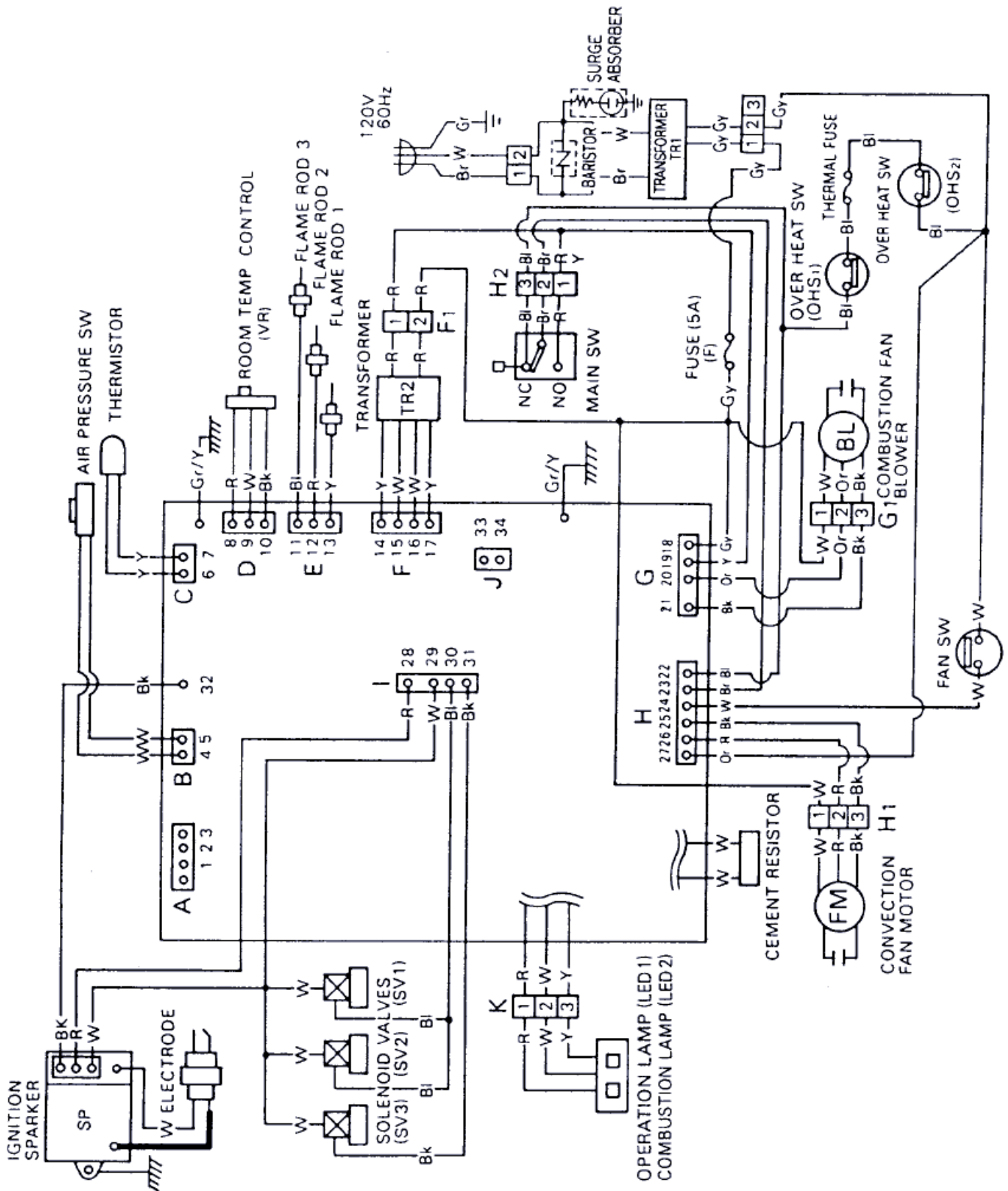

**⚠ WARNING**

There are a number of live tests that are required when fault finding this product. Extreme care should be used at all times to avoid contact with energized components inside the furnace.

You **MUST** be a qualified service person before proceeding with these test instructions.

Before checking resistance readings, turn off power source to unit and then isolate each item to be checked from the circuit by unplugging it.

When setting gas pressures on one of these units, please check the complete model number you are trouble-shooting. Gas pressures and dip switches can vary among models. Always check the rating plate for complete information and follow directions.

**(TR2) Transformer:**

Read voltage across:		Read resistance	Pin #'s
Red - Red	98 - 105 VAC	39 - 44 ohms	21 - 22
Yellow - Yellow	208 - 224 VAC	490 - 510 ohms	19 - 20
White - White	10 - 15 VAC	2.5 - 3.1	17 - 18

**(SP) Sparker:**

Grey -----  
 85 - 95 VDC    N/A    37 - 38  
 Blue -----

**(SV1, SV2, SV3) Gas solenoids:**

SV1 - Gray ~ Black (redundant)	85 - 90 VDC	1,400 - 1,800 ohms	33 - 36
SV2 - Gray ~ Blue (lo fire)	85 - 90 VDC	1,200 - 1,600 ohms	34 - 36
SV3 - Gray ~ White (hi fire)	85 - 90 VDC	1,200 - 1,600 ohms	35 - 36

**(BL) Combustion fan motor:**

White - Orange = lo speed	95 - 105 VAC	200 - 300 ohms	29 - 31
White - Black = hi speed	95 - 105 VAC	120 - 180 ohms	30 - 31

White - Red = lo speed	95 - 105 VAC	100 - 140 ohms	26 - 28
White - black = hi speed	95 - 105 VAC	42 - 62 ohms	27 - 28

**(TR1) Transformer:**

Black - White = primary	110 - 125 VAC	19 - 20 ohms	n/a
Grey - Grey = secondary	95 - 105 VAC	19 - 20 ohms	n/a

**(PS) Pressure switch:**

Brown - Ground	13 - 18 VDC	n/a	6 - 7
----------------	-------------	-----	-------

Check from both brown's to ground to ensure circuit is complete.

Room Temperature Thermistor

Yellow - Yellow		10-100 kΩ	
-----------------	--	-----------	--

Flame Rod 

0.8 μA or greater
-------------------

**CAUTION: WHERE # APPEARS DISCONNECT ELECTRICAL PLUG BEFORE PROCEEDING WITH TEST.**

NATURE OF FAULT	EXAMINATION POINT	DIAGNOSTIC POINT	VALUES	ACTION
<b>TABLE A</b> The ON indicator does not glow after having switched the appliance ON. Due to Power Failure Safety Circuit, the appliance will not operate again until the ON/OFF button is pushed off, then on gain.	#1 Is the electrical plug in the wall socket firmly? Is the voltage normal?	<ul style="list-style-type: none"> <li>Check the electrical connection and voltage. (Tester ACV range)</li> </ul>	120V ± 15%	YES → Go to 2 NO → Rectify
	#2 Is the power transformer O.K.?	<ul style="list-style-type: none"> <li>Confirm the resistance of the power transformer. Remove electrical cord from wall socket.</li> </ul>	White - Black → 15 ~ 20 Ω? Gray - Gray → 15 ~ 20 Ω?	YES → Go to 3 NO → Change transformer
	#3 Has the thermal fuse, electrical fuse or O.H.S. blown?	<ul style="list-style-type: none"> <li>Check the continuity through the fuses and OHS (Tester Ω range).</li> </ul>	Approx. 0 Ω → normal	YES → Go to 4 NO → Fuse → Table B OHS/TF → Table H
	#4 Is the movement of the ON/OFF button normal?	<ul style="list-style-type: none"> <li>With the appliance OFF, remove the connector and check the continuity of the blue - brown, brown - red wires. (Tester Ω range)</li> </ul>	Blue - Brown → Approx. 0 Ω is → normal Brown - Red → Approx. ∞ Ω is → normal	YES → Go to 5 NO → Replace ON/OFF switch
	#5 Is the LED P.C.B. O.K.?	<ul style="list-style-type: none"> <li>Check the resistance of the white, yellow indicator connecting wire (Tester Ω range)</li> </ul>	⊕ → white - ⊖ → yellow = ∞ Ω ⊕ → yellow - ⊖ → white = 1 MΩ	YES → Go to 6 NO → Replace indicator panel
	#6 Is the P.C.B. O.K.?	<ul style="list-style-type: none"> <li>Locate and undo 3 pin connection from P.C.B. to LED indicator panel. Measure the voltage of the Y - W on the P.C.B. side. W → ⊕, Y → ⊖. (measure within 30 seconds of turning unit on).</li> </ul>	White - yellow DC 14 V ~ 23 V	YES → Go to 7 NO → Replace P.C.B.
	#7 Is the transformer O.K.? (TR 2)	<ul style="list-style-type: none"> <li>Check the resistance of the transformer. (Tester Ω range)</li> </ul>	Red - Red → 45 ~ 70 Ω White - White → 1.8 ~ 2.5 Ω Yellow - Yellow → 390 ~ 550 Ω	YES → Replace P.C.B. NO → Replace transformer



NATURE OF FAULT	EXAMINATION POINT	DIAGNOSTIC POINT	VALUES	ACTION
<b>TABLE B</b> The electrical fuse blows when the appliance is turned ON.	#1 Is the transformer O.K.? (TR 2)	● Check the resistance of the transformer.	Red - Red → 45 ~ 70 Ω	YES → Go to <b>2</b> NO → Replace transformer
	#2 Has the ballast resistor shorted?	● Measure the resistance of points 26-27 on the P.C.B.	∞ Ω → Normal	YES → Go to <b>3</b> NO → Replace P.C.B.
	#3 Is combustion fan motor operating correctly?	● Check the resistance of the combustion fan motor. (Tester Ω range)	White - Orange → 200 ~ 300 Ω White - Black → 120 ~ 180 Ω	YES → Go to <b>4</b> NO → Replace combustion fan motor
	#4 Is the spark generator O.K.?	● Check the resistance between the gray - blue connecting terminal. (Tester Ω range)	∞ Ω → O.K.	YES → Go to <b>3</b> NO → Replace sparker
	#5 Are the solenoids operating correctly?	● Release the pin connectors from each solenoid valve and check the resistance between both solenoid terminals. <b>Warning: Do not pull on the wires.</b> (Tester Ω range).	SV <sub>1</sub> 1.3 ~ 1.8 kΩ SV <sub>2</sub> 1.0 ~ 1.5 kΩ SV <sub>3</sub> 1.3 ~ 1.8 kΩ	YES → Go to <b>5</b> NO → Replace solenoids
	#6 Is the convection fan motor operating correctly?	● Release the convection fan motor pin connector. Check the resistance of the white - red, white - black wires (Ω range)	White - Red → 100 ~ 140 Ω White - Black → 50 ~ 70 Ω	YES → Replace P.C.B. NO → Replace convection fan motor
<b>TABLE C</b> 10 seconds after switching ON, the ON indicator goes out.  The combustion fan motor does not rotate during this interval.	#1 Is the combustion fan motor operating correctly?	● Check the resistance at the connecting terminal. (Tester Ω range)	White - Orange → 200 ~ 300 Ω White - Black → 120 ~ 180 Ω	YES → Go to <b>2</b> NO → Replace combustion fan motor
	#2 Is the combustion fan motor capacitor operating correctly?	● Alternate the tester between the ⊖ & ⊕ terminals of the capacitor and check the resistance.	Does the tester oscillate for a moment then return to ∞ Ω?	YES → Go to <b>3</b> NO → Replace the capacitor
	3 Are the P.C.B. connections O.K.?	● Check the voltage of the white - black 3 pin connecting wire.	AC 90 ~ 110 Volts	YES → Confirm combustion fan motor connector contacts NO → Replace the P.C.B.
<b>TABLE D</b> During the first 10 seconds after switching appliance ON the combustion fan operates twice from HI to LOW before the indicator goes out.	1 Is the sparker operating correctly?	● Check the DC voltage at the ⊖ gray - ⊕ blue connector.  <b>NOTE:</b> Only voltage whilst the combustion fan is running on LOW.	DC 80 ~ 100 Volts	YES → Replace the sparker NO → Go to <b>2</b>
	2 Is the P.C.B. operating correctly?	● Check the DC voltage at the terminal that connects with the ⊖ gray - ⊕ blue wires.	DC 80 ~ 100 Volts	YES → Replace sparker NO → Replace P.C.B.

NATURE OF FAULT	EXAMINATION POINT	DIAGNOSTIC POINT	VALUES	ACTION
<b>TABLE E</b> There is no spark and the combustion indicator does not glow.	<b>1</b> Check that the high tension cord and spark lead are firmly in position.	• Disconnect power, check and confirm the connections by hand.	Tight – no insulation leaks?	YES → Go to <b>2</b> NO → Rectify the connections
	<b>#2</b> Are the solenoids SV <sub>1</sub> & SV <sub>2</sub> O.K.?	• Release the pin connectors from each solenoid valve and check the resistance between both solenoid terminals. <b>Warning: Do not pull on wires.</b> (Tester Ω range)	SV <sub>1</sub> 1.3 ~ 1.8 kΩ SV <sub>2</sub> 1.0 ~ 1.5 kΩ	YES → Go to <b>3</b> NO → Replace the solenoids
	<b>#3</b> Is the transformer O.K.? (TR 2)	• Release the transformer pin connector and check the resistance of the white – white wires. (Tester Ω range)	1.8 kΩ ~ 2.5 kΩ	YES → Go to <b>4</b> NO → Replace the transformer
	<b>4</b> Is the LOW burner flame rod clean? Does the burner ignite?	• Confirm the flame rod current between the FR and yellow pin connector. Measure at the point of ignition.	Yellow – Fr1 Above 1.0 μA.	YES → Replace P.C.B. NO → Check insulation
<b>TABLE F</b> The appliance ignites on the LOW burner, but goes to lockout after several seconds.	<b>1</b> Are the injectors, gas pressure, damper, gas pipe sizing and gas filter all clean?	• Are there blockages in any of these areas?	Is everything correct?	YES → Go to <b>4</b> NO → Rectify
	<b>2</b> Does SV <sub>3</sub> open?	• Release the pin connectors from solenoid valve and check the resistance between both solenoid terminals. <b>Warning: Do not pull on wires.</b> (Tester Ω range)	Is there an opening sound?	YES → Go to <b>3</b> NO → Replace solenoid
			#1.3 ~ 1.8 kΩ?	YES → Go to <b>3</b> NO → Replace solenoids
	<b>3</b> Is the P.C.B. O.K.?	Confirm the DC voltage of the P.C.B. connections to SV <sub>3</sub> .	DC 80 ~ 100 Volts	YES → Go to <b>4</b> NO → Replace P.C.B.
<b>4</b> Is the area surrounding both HI burner flame rods clear and O.K.?	Confirm the flame rod current.	Above 0.8 μA	YES → Check symptoms again NO → Replace the flame rod	
<b>TABLE G</b> The thermostat control does not modulate.	<b>#1</b> Is the thermistor O.K.?	• Release the thermistor connector and check the thermistor resistance. (Tester Ω range)	41°F = 5°C = 91 kΩ 50°F = 10°C = 65 kΩ 68°F = 20°C = 39 kΩ 86°F = 30°C = 23 kΩ	YES → Go to <b>2</b> NO → Replace the thermistor
	<b>#2</b> Is the thermostat slide control operating correctly?	• Release the thermostat control pin connectors, and confirm the resistance of the white – red & white – black wires. (Ω range)	Does it vary from 0 Ω ~ 30 kΩ?	YES → Replace the P.C.B. NO → Replace the thermostat slide control

NATURE OF FAULT	EXAMINATION POINT	DIAGNOSTIC POINT	VALUES	ACTION
<b>TABLE H</b> The flame goes out during normal operation. [Flame failure] Check the air filter and gas pressure.	<b>1</b> Are the convection fan revolutions correct? [If it's low then the O.H.S. will be activated]. HI → above 700 rpm. LOW → above 400 rpm.	• 1.1 Confirm the voltage at the convection fan motor connectors. HI → White - Black LOW → White - Red	AC 90 ~ 110 Volts	YES → Go to <b>1.2</b> NO → Replace the P.C.B.
		• 1.2 Release the convection fan motor pin connector. Check the resistance of the white - red, white - black wires.	White - Red → 100 ~ 140 Ω? White - Black → 50 ~ 70 Ω?	YES → Go to <b>1.3</b> NO → Replace the convection fan motor
		• 1.3 Alternate the tester between the ⊕ & ⊖ terminals of the convection fan motor capacitor and check the resistance.	Does the tester oscillate for a moment, then return to ∞ Ω?	YES → Go to <b>2</b> NO → Replace the capacitor
	<b>2</b> Are the O.H.S. No. 1, No. 2 operating correctly?	• Check the temperature marked on the O.H.S.	No. 1 = A 65°C? No. 2 = A 130°C?	YES → Go to <b>3</b> NO → Replace the O.H.S.
	<b>#3</b> Is the air pressure switch operating normally?	• Check the air pressure switch is de-activated when the combustion fan goes off.	Is the value ∞ Ω?	YES → Check symptoms again NO → Replace the air pressure switch
<b>TABLE I</b> Operation of the appliance continues as normal but the combustion indicator does not glow.	<b>1</b> Is the combustion indicator blown?	• 1.1 Release the combustion indicator connector and check the resistance of the white - red wires.	⊕ White - ⊖ Red → ∞ Ω ⊕ Red - ⊖ White → 140 kΩ	YES → Go to <b>1.2</b> NO → Replace the indicator P.C.B.
		• 1.2 Check the DC voltage of the ⊖ red - ⊕ white lead coming from the P.C.B.  Appliance must be operating for P.C.B. to operate indicators.	DC 14 ~ 23 Volts → normal	YES → Replace indicator P.C.B. assembly NO → Replace P.C.B.

**IMPORTANT SAFETY NOTE:**

**A NUMBER OF ENERGIZED (LIVE) TESTS ARE REQUIRED TO BE DONE IN THE FAULT FINDING PROCEDURES.**

**EXTREME CARE WILL BE NEEDED AT ALL TIMES.**

Wire Diagram

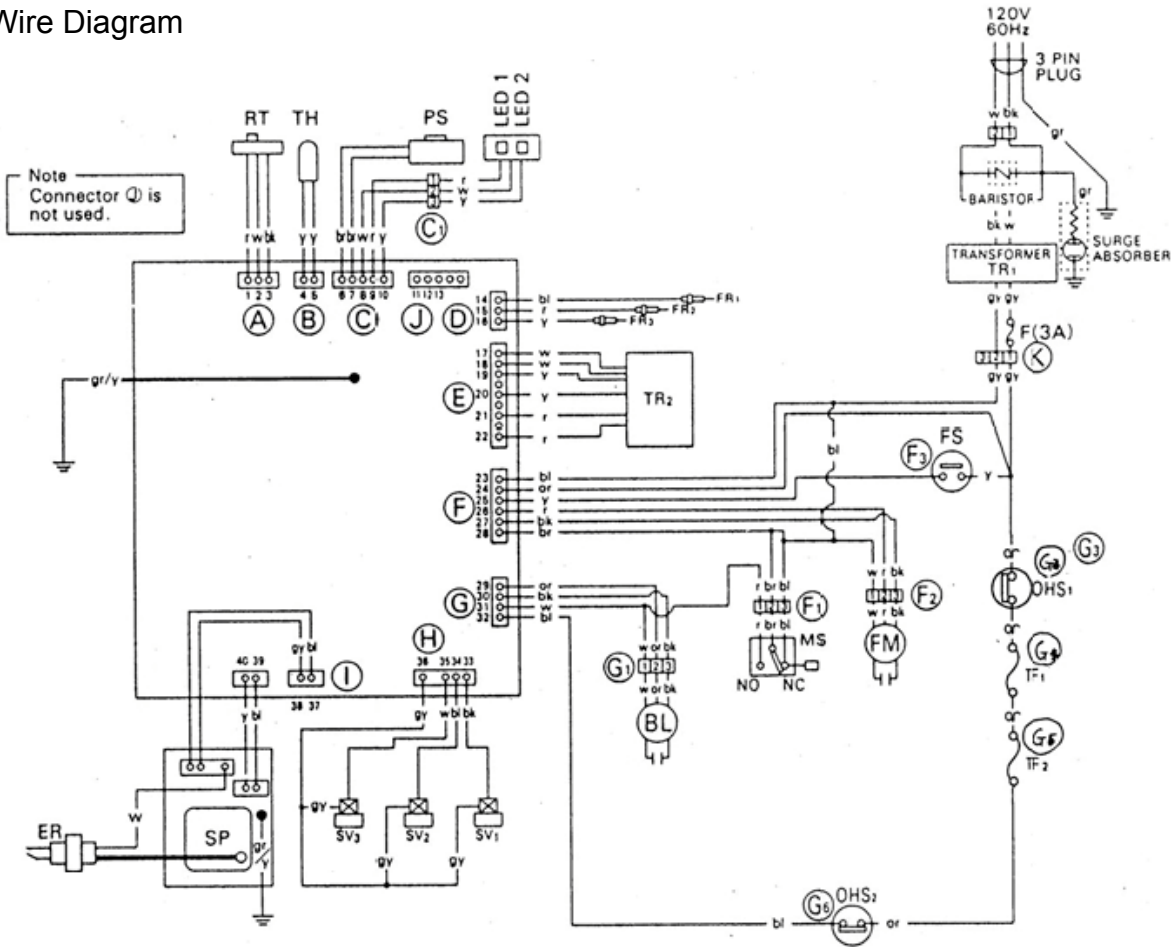

Ladder Diagram

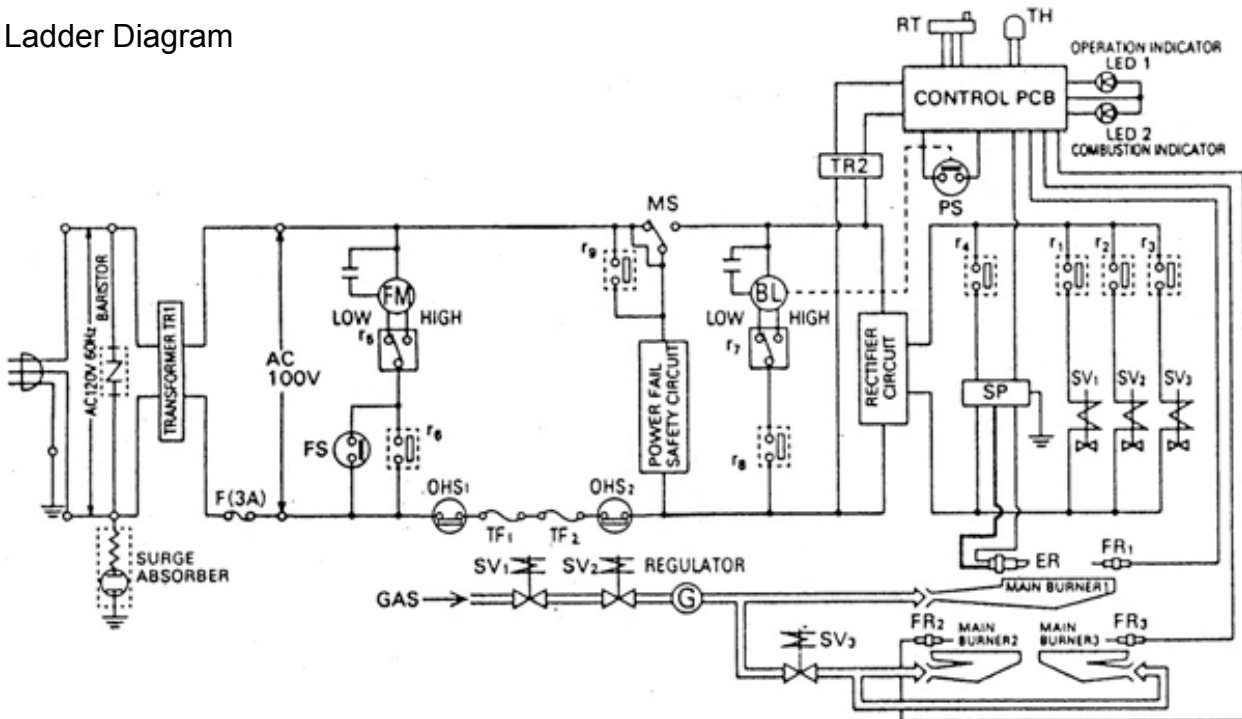

1. Check gas pressure at manifold, pressure should be:
  - 9.4" W.C. for RHFE 551 FA on propane.
  - 3.5" W.C. for RHFE 551 FA on natural.
  - 10.5" W.C. for RHFE 1001 FA/VA on propane
  - 3.8" W.C. for RHFE 1001FA/VA on natural
2. Check air shutters adjustment:
  - RHFE 551 FA set for propane should have seven notches showing on adjustment rod.
  - RHFE 551 FA for natural should have two notches showing on adjustment rod
  - RHFE 1001 FA/VA set for propane should have no notches showing on rod.
  - RHFE 1001 FA/VA set for natural should have 5 notches showing on the back two burners and 3 notches showing on the front right burner.
3. Ensure unit has the proper size orifices in it:
  - Orifice sizes for the RHFE 551 FA on propane should be 1.00mm (0.039")
  - Orifice sizes for the RHFE 551 FA on natural should be 1.70mm (0.067")
  - Orifice sizes for the RHFE 1001 FA/VA on propane should be 1.05mm (0.041") on the back two burners and 1.15mm (0.045") on the front right burner.
  - Orifices sizes for the RHFE 1001FA/VA on natural should be 1.9mm (0.074") on the back two burners and 1.80 mm(0.071") on the right front burner.
4. On the RHFE 551 FA's **ONLY**, ensure the proper size bypass restrictor screw is in place:
  - Propane restrictor screw size is 1.15mm.
  - Natural restrictor screw size is 3.55mm.
5. Inspect wall vent to ensure it is not clogged or restricted in any way. For proper inspection of combustion chamber air way, vent **MUST** be removed from wall.
6. Remove all flame rods and electrodes and inspect for cracks and/or carbon buildup. Clean flame rods and electrode with some type sandpaper. Also check electrode for proper gap setting (0.12" - 0.16").
7. Check all wire connections for loose or broken pins or connectors. Disconnect electrical power before performing this task.
8. Check resistance on all three gas valve solenoids. Unplug each coil before checking resistance. Set you meter on the 2K scale, you should read somewhere between 1000 to 1800 ohms across each coil. Power unit back up and set your meter to read 100 VDC scale, cycle unit and check voltage to each coil. You should read 90VDC at each coil. If unit goes to lockout before you have time to read all coils, you may have to cycle it two or three times.
9. Check voltage on the (4) pin or (6) pin connector located on the front of the PC board. See below for proper voltages and wire colors per unit.
  - All RHFE 551 FA's Have a four pin connector with two yellow wires and two white wires. Set meter to read 220 VAC, then insert meter leads into connector. Across the two yellow wires you should read 220 VAC, and 15 VAC across the two white wires.
  - All RHFE 1001 FA's have a four pin connector with two yellow wires and two white wires. Set meter to read 220 VAC, then insert meter leads into connector. Across the two yellow wires you should read 220 VAC, and 15 VAC across the two white wires.
  - All RHFE 1001FA/VA's have a six pin connector with two yellow wires, two white wires, and two red wires. Set meter to read 220 VAC, Then insert meter leads into connector. Across the two yellow wires you should read 220 VAC, across the two white wires 15 VAC, and 100 VAC across the two red wires.

- Ensure the air pressure switch is functioning properly. Ohm out the micro-switch located on the pressure switch. Continuity will be read on meter when closed position.
  - Ensure the vent system does not exceed fifteen feet total run, not exceeding 8 feet vertically, with no more than two bent elbows.
  - Check slide thermostat, set your meter to the 200K ohm scale. By reading across the white and black wires, you should have an ohm range from 0 to 30 ohms from low to high on the RHFE 1001 units. On the RHFE 551 FA units read from red to red wires you should read 30 ohms from low to 0 ohms on high.
  - Check thermistor operation by inserting meter leads into each end of thermistor plug. Disconnect yellow to yellow from PCB, set your meter on the 200K scale. You should be able to apply heat to the thermistor bulb and see resistances decrease. Place some ice on thermistor bulb and resistances should increase.
10. Check current on all flame rods:
- \_\_\_ RHFE 551 FA only has one flame rod. On the low burner this current should be 1 to 2 micro amps and on high, current should be 5 to 6 micro amps.
  - \_\_\_ RHFE 1001 FA and RHFE 1001FA/VA uses only one flame rod on low fire. This is the front flame rod nest to the electrode. Current on this rod should be 1 to 2 micro amps on start up. There are three total flame rods on these units, and on high 5 to 6 micro amps should be measured.

**YOU MUST ENSURE UNIT IS GROUNDED !!**

**⚠ WARNING**

There are a number of live tests that are required when fault finding this product. Extreme care should be used at all times to avoid contact with energized components inside the furnace.

You MUST be a qualified service person before proceeding with these test instructions.

Before checking resistance readings, turn off power source to unit and then isolate each item to be checked from the circuit by unplugging it.

When setting gas pressures on one of these units, please check the complete model number you are trouble-shooting. Gas pressures and dip switches can vary among models. Always check the rating plate for complete information and follow directions.

**(AC IN)**

Read voltage across:	Voltage Potential	Pin Numbers
Black-White	120 VAC	Pin # 1-2

**(TR2) Transformer: (Connector CN2 AC Out)**

Read voltage across:	Voltage Potential	Read resistance	Pin Numbers
Gray - Gray	98-125 VAC	4--6 Ω	1-7
White - White	98-125 VAC	4--6 Ω	2-3
Red - Red	35 VAC	1--2 Ω	4-10
Black - Yellow	200-220 VAC	250--300 Ω	5-8
Black - Blue	17 VAC	1--2 Ω	8-9

**(SP) Sparker: (Connector CN4)**

Read voltage across:	Voltage Potential	Read resistance	Pin Numbers
Red-Blue	85-100 VAC	105K-115K Ω	3-6

**(SV1, SV2, SV3, POV) Main Solenoid Valves: (Connector CN4)**

Read voltage across:	Voltage Potential	Read resistance	Pin Numbers
SV1 - Yellow ~ Black (hold)	85-90 VDC	1400-1800 Ω	1-4
SV2 - Yellow ~ Black (assist)	85-90 VDC	1200-1600 Ω	1-4
SV3 - Black ~ Pink	85-90 VDC	1200-2000 Ω	2-5
POV - Gray ~ Gray	6-16 VDC	80-90 Ω	2-6

**(BL) Combustion Fan Motor: (Connector CN8) DC Motor 37VDC 8 Watts**

Read voltage across:	Voltage Potential	Read resistance	Pin Numbers
Black-White	7-12 VDC	8-10 KΩ	7-8
Yellow-White	4-5 VDC	4-6 KΩ	4-8
Red-White	10-30 VDC	N/A	3-8

**(FM)**

Read voltage across:	Voltage Potential	Read resistance	Pin Numbers
Black-Red	40-105 VAC	25-50 Ω	1-2

\* Be sure to check for obstructions to blades. Check the capacitor before replacing motor.

**(PS) Pressure Sensor:**

Electronic	0.31 in (8.0 mm) WC <b>ON</b>	0.11 in (2.8 mm) WC <b>OFF</b>
------------	----------------------------------	-----------------------------------

Note: Ensure clear and black hose from pressure switch to blower air chamber is not blocked or crimped with any obstructions including spider webs.

**(TH) Room Thermistor:**

Check thermistor by inserting meter leads into each end of thermistor plug. Set your meter to the 200 KΩ scale. Apply heat to the thermistor bulb and the resistance should decrease. Apply cold and the resistance should increase. Examples of readings:  
41°F=91KΩ 50°F=65KΩ 68°F=39KΩ 86°F=23KΩ

**(FR1, FR2, FR3) Flame Rod**

FR1 and FR2 are high fire flame rods. The left hand rod (FR1) is a blue wire and the right hand rod (FR2) is a red wire. Flame current through these rods should range from 4 to 8 micro amps (μ amps) depending on gas type being used. FR3 fire flame rod is the yellow wire located on the front center of the unit next to the electrode. Low fire flame current should be 1.2 to 2.0 micro amps (μ amps).

***Improperly setup and /or converted units can soot and cause hard lockouts. If carbon is found on the flame rod, clean the carbon from it. Confirm that your manifold differential gas pressure on Hi fire and Lo fire is correct. Insure primary and secondary air dampers are correct. Check to ensure proper orifices were placed in the unit.***

**IMPORTANT INFORMATION CONCERNING HARD LOCKOUTS:**

Other items that can cause hard lockouts are: improper sized gas lines, low gas pressures or pressure drops due to other appliances on the gas system, spider webs in the burner and air intake of vent system, improper ground or no ground at receptacle, supply regulators freezing up or defective, voltage drops or bad receptacles, winds in excess of 40 mph causing turbulence inside the vent terminal, etc.

**(OHS1, OHS2, TF1, TF2) Safety Circuit Check: CN8**

Check for continuity reading from pin #1 white wire to pin #5 blue wire. If you do not read continuity through this circuit, locate defective switch and replace that component. Determine what caused overheat condition.

**(MS) Main Switch: CN11**

Disconnect CN11 from PCB, being careful not to break wires. Read Blue to Blue, pin #9 and 10 on 40KΩ . When ON/OFF is in the ON position, you should read 10--18KΩ. When released, you should read open or 0 Ω

Wiring harness, connectors, and fuses should be checked if all above readings are normal.



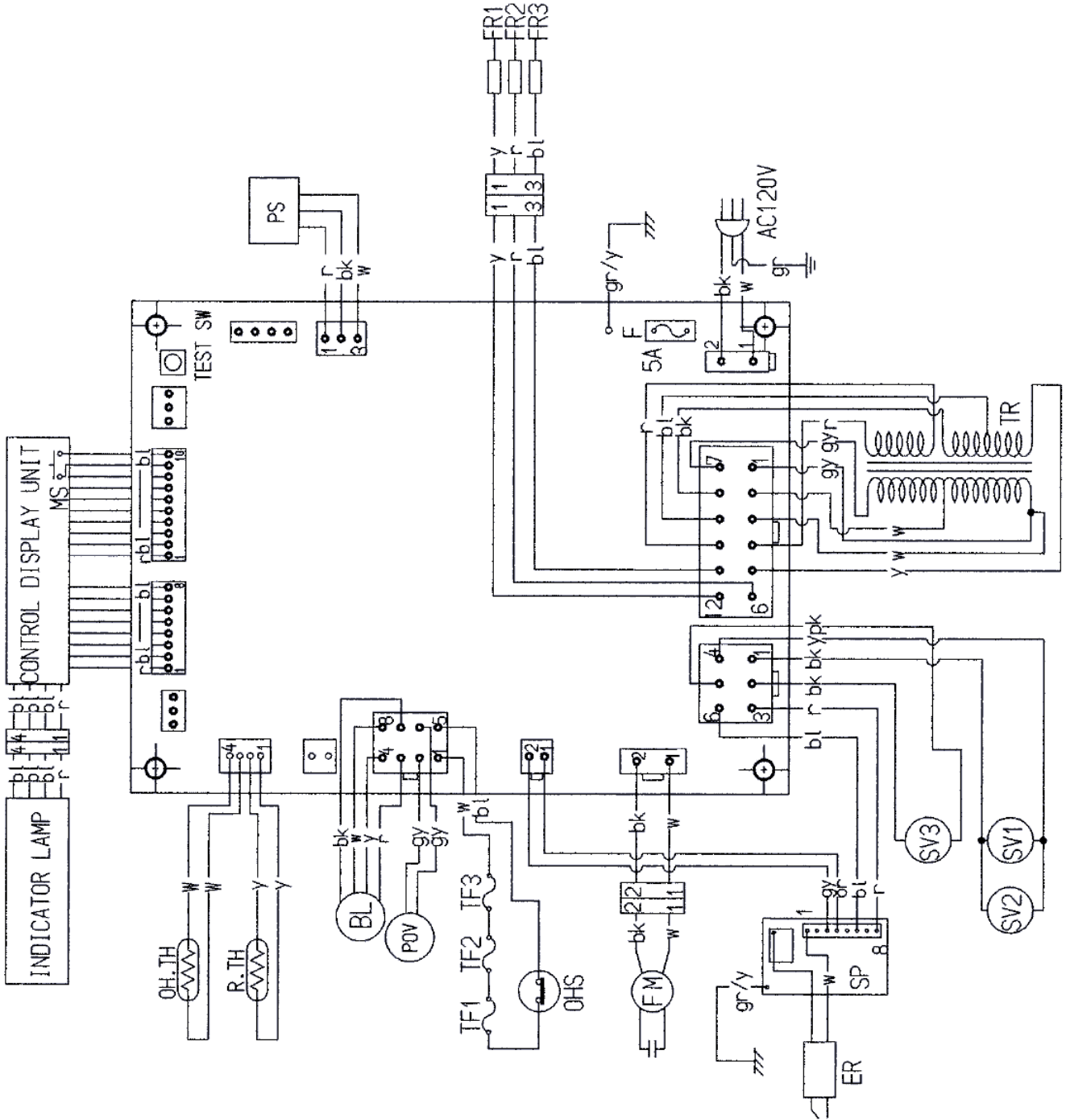

RHFE-1004FA  
RHFE-1004RFA  
RHFE-1004FTA

MARK	PART
MS	MAIN SWITCH
R.TH	THERMISTOR
TF1~3	THERMAL FUSE 1~3
F	FUSE
ER	ELECTRODE
POV	MODULATING VALVE
TR	TRANSFORMER
FR1~3	FLAME ROD 1~3
OH.TH	OVERHEAT THERMISTOR
OHS	OVERHEAT SWITCH
FM	CONVECTION FAN MOTOR
SP	SPARKER
SV1~3	SOLENOID VALVE 1~3
BL	COMBUSTION FAN MOTOR
PS	PRESSURE SENSOR
CF	CONVECTION FAN
FCC	FAN CONTROL CIRCUIT
CPU	CENTRAL PROCESSING UNIT
B1~3	BURNER 1~3

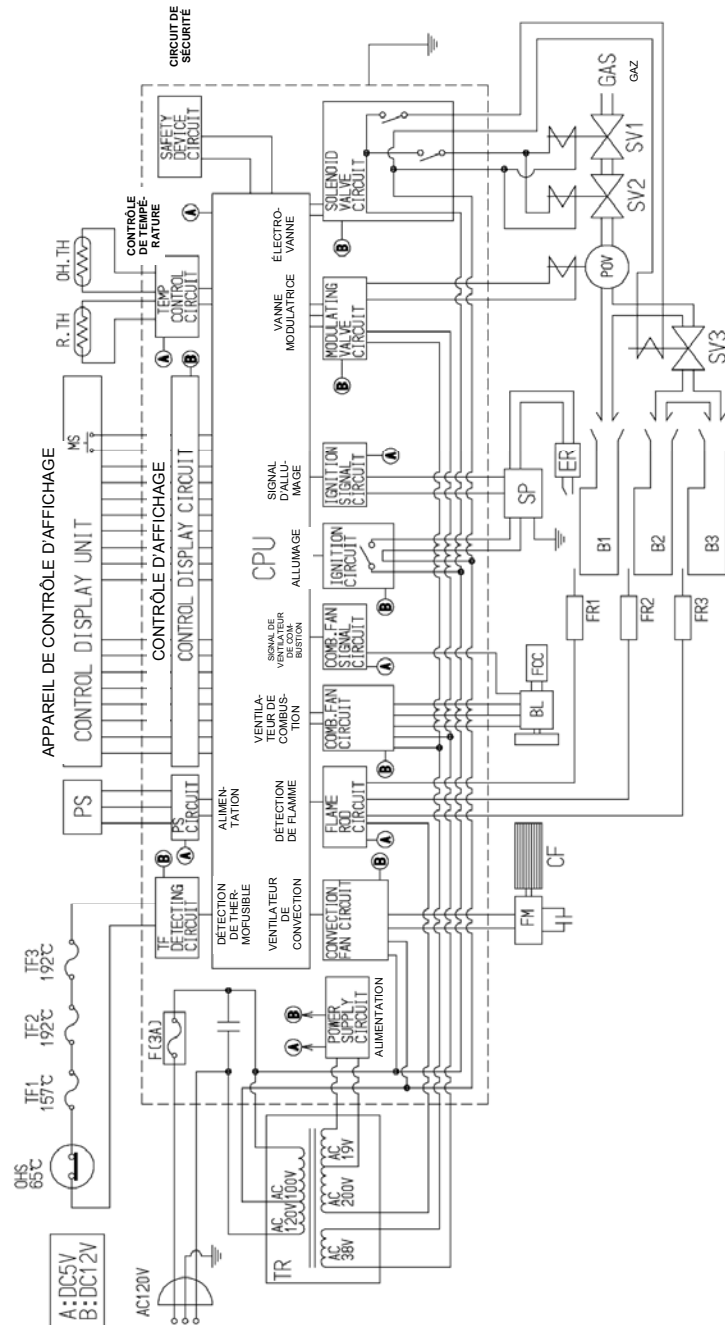

1. Check gas pressure at manifold, pressure should be:

Altitude	Gas Type	Manifold Differential Pressure	
		High (in W.C.)	Low (in W.C.)
0-2000 ft (0-610 m)	LPG / Propane	10.1	4.3
> 2000 ft (> 610 m)		7.3	4.3
0-2000 ft (0-610 m)	Natural Gas	3.7	2.0
> 2000 ft (> 610 m)		2.7	2.0

2. Check air shutters adjustment:

- \_\_\_ RHFE1004FA set for propane should have no notches showing on adjustment rod.
- \_\_\_ RHFE1004FA set for natural: the right rear and left hand shutters should have no notches showing on adjustment rod; the right front shutter should have 3 notches showing on the rod.

3. Ensure unit has the proper size orifices in it:

- \_\_\_ Orifice sizes for the RHFE1004FA/VA on propane should be 0.95 mm (0.037") on the back two burners and 1.20 mm (0.047") on the front right burner.
- \_\_\_ Orifices sizes for the RHFE1004FA/VA on natural should be 1.8 mm (0.071") on the back two burners and 1.95 mm (0.077") on the right front burner.

5. Inspect wall vent to ensure it is not clogged or restricted in any way. For proper inspection of combustion chamber air way, vent MUST be removed from wall.

6. Remove all flame rods and electrodes and inspect for cracks and/or carbon buildup. Clean flame rods and electrode with some type of sandpaper.

7. Check all wire connections for loose or broken pins or connectors. Disconnect electrical power before performing this task.

8. Check resistance on all three gas valve solenoids. Unplug each coil before checking resistance. Set you meter on the 2K scale, you should read between 1400 to 1800 ohms for SV1; 1200-1600 ohms for SV2; and 1200-2000 ohms for SV3. Power unit back up and set your meter to read 100 VDC scale, cycle unit and check voltage to each coil. You should read 85-90 VDC at each coil. If unit goes to lockout before you have time to read all coils, you may have to cycle it two or three times.

9. Ensure the air pressure switch is functioning properly. Ohm out the micro-switch located on the pressure switch. Continuity will be read on meter when closed position.

10. Ensure the vent system does not exceed 13 feet total run, not exceeding 8 feet vertically, with no more than two bent elbows.

11. Check thermistor operation by inserting meter leads into each end of thermistor plug. Disconnect yellow to yellow from PCB, set your meter on the 200K scale. Your should be able to apply heat to the thermistor bulb and see resistances decrease. Place some ice on thermistor bulb and resistances should increase.

12. Check current on all flame rods:

- \_\_\_ FR1 and FR2 are high fire flame rods. The left hand rod (FR1) is a blue wire and the right hand rod (FR2) is a red wire. Flame current through these rods should range from 4 to 8 micro amps (μ amps) depending on gas type being used. FR3 fire flame rod is the yellow wire located on the front center of the unit next to the electrode. Low fire flame current should be 1.2 to 2.0 micro amps (μ amps).

**YOU MUST ENSURE UNIT IS GROUNDED !!**

## *Extension Installation Requirements*

---

### DIRECT VENT EXTENSION INSTALLATION REQUIREMENTS

The purpose of these instructions is to explain the correct application of the vent extension sets for the Energy Saver direct vent furnaces.

- Two elbows can be used. Do not count the elbow attached to the unit.
- Refer to the manual for details on the maximum vent run and maximum vertical length.
- Do not allow any low points in the exhaust line.
- Termination must always be horizontal.
- The vent pipe extension must not be concealed per NFPA 54 and must be accessible allowing inspection and repair. Decorative covers are available from Rinnai.
- The exhaust elbow assembly attached on the back of the unit SHALL NEVER be straightened.
- Do not shorten the intake air hose attached to unit from factory.
- Vent extensions ran in ANY unconditioned air space MUST be insulated with high temperature insulation and must be accessible.
- All pipe stoppers, connectors, screws, and hangars must be used as per the directions. The seals must be air tight for both the exhaust and the intake air supply hose.
- The intake air hose must equal the exhaust hose length to maintain a balanced flue system.
- The 431/556 Series units have a terminal block on the back that must be changed as per directions for any extension set. This terminal block is set for direct through the wall installation and must be changed if an extension set is used.
- The humidifier trays are made of enamel covered steel to resist rust and corrosion from the condensate draining back to the unit. For most models the trays can be removed for cleaning but must be replaced before operation of the unit. The 1004FA, 1004RFA, and 1004FTA tray can only be removed by a service technician.
- Over flow of the humidifier tray is an indication that the venting extension installation directions have not been followed and no warranty claim will be approved covering overflow.

Model	Trade Name	Maximum Vent Length	Maximum Vertical Vent Length*
RHFE-551FA RHFE-1001FA RHFE-1001FA/VA		15 feet, 2 bends	
RHFE-201FA RHFE-201RFA RHFE-202FTA	ES08 EX08C	Extended venting is not allowed	
RHFE-263FA		13 feet (4 m), 2 bends	
RHFE-263FAII		13 feet (4 m), 2 bends	Maximum vertical length is 8 feet (2.4 m)*
RHFE-431FA, FAII, FAIII, WTA RHFE-556FA, FAII, FAIII, FTRA, FTRAI, WTA RHFE-1004FA		13 feet (4 m), 2 bends	
RHFE-263RFA RHFE-265FTA	ES11 EX11C	13 feet (4 m), 2 bends	Below 2000 ft, maximum vertical length is 8 feet (2.4 m)* Above 2000 ft, maximum vertical length is 5 feet (1.5 m)*
RHFE-433RFA RHFE-433RWTA RHFE-558RFA RHFE-558RWTA RHFE-434FTA RHFE-559FTA	ES17 EX17 ES22 EX22 EX17C EX22C	13 feet (4 m), 2 bends	Maximum vertical length is 10 feet (3.0 m)*
RHFE-1004RFA	ES38	13 feet (4 m), 2 bends	Maximum vertical length is 8 feet (2.4 m)*
RHFE-1004FTA	ES38	13 feet (4 m), 2 bends	

If the combined vertical and horizontal extension length is longer than these values, the condensate may overflow the condensation pan. Therefore, extensions exceeding this length should drain and slope 3° downward to the outside.

## Vent Kits and Extensions Sets

### **Vent Kits for the RHFE 201, 202, 263, 265, 431, 433, 434, 556, 558, 559, 1004 Series**

KIT NO.	NAME	WALL THICKNESS
FOT-150	Vent Kit S	3" to 4-1/2"
FOT-151	Vent Kit A *	4-1/2" to 9-1/2"
FOT-152	Vent Kit B	9-1/2" to 15-3/4"
FOT-153	Vent Kit C	15-3/4" to 23-5/8"
FOT-154	Vent Kit D	23-5/8" to 31-1/2"

\* Standard vent kit shipped with appliance.

The exhaust adaptor B assembly, P/N 1004F-530X01, is shipped with every 1004 appliance and must be installed on the vent termination end every time, even when using extension sets. This allows the same vent termination kit to be used on all 1004FA models produced in 1999.

### **Vent Kits for the RHFE 1001FA Series**

KIT NO.	WALL THICKNESS
FOT-175 or 1001F-1670	3" to 4-1/2"
FOT-176 or 1001F-1671	4-1/2" to 9-1/2"
FOT-177 or 1001F-1672	9-1/2" to 15-3/4"
FOT-178 or 1001F-1673	15-3/4" to 23-5/8"
FOT-179 or 1001F-1674	23-5/8" to 31-1/2"

### **Vent Extensions for the RHFE 263, 265, 431, 433, 434, 556, 558, 559 Series**

KIT NO.	NAME
FOT-155	Extension Set - 20"
FOT-156	Extension Set - 40"
FOT-157	Extension Set - 80"
FOT-158 *	Elbow Set - 90 Degrees
FOT-190	Elbow Set - 90 Degrees - Long



\* A maximum of one elbow (FOT-158) may be used on the RHFE-201FA to raise the flue manifold's position by 6 in (154 mm) relative to the appliance.

### **Vent Extensions for the RHFE 1001 and 1004 Series**

KIT NO.	NAME
FOT-102	Extension Set - 20"
FOT-103	Extension Set - 40"
FOT-114	Extension Set - 80"
FOT-115	Elbow Set - 90 Degrees

## Vent Extension Covers

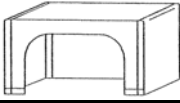
### Vent Extension Covers for the RHFE 263, 265, 431, 433, 434, 556, 558, 559 Series

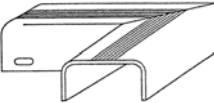
KIT NO.	NAME	
FOT-132	Manifold Cover	
FOT-133	Straight Cover	
FOT-134	Elbow Cover	

### Vent Extension Covers for the RHFE 1001 and 1004 Series

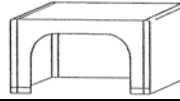
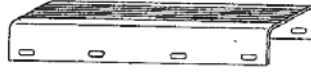
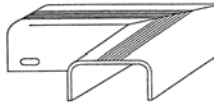
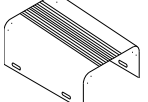
KIT NO.	NAME	
FOT-140	Manifold Cover	
FOT-141	Straight Cover	
FOT-142	Elbow Cover	
FOT-162	Cover for First Piece on RHFE-1004FA *	

\* This piece has a smaller cross section at one end to allow the filter to be removed for cleaning.

## *Installations at Altitude*

### **Models RHFE-201FA, RHFE-263FA, RHFE-263FAII, RHFE-1004FA**

The PC boards of these models have altitude settings which allows operation up to 10,200 feet (3109 m). The correct altitude is entered using switches on the PC board and the appliance control buttons.

When installing these models, follow the Gas Pressure Setting Procedure for your model.

### **Models RHFE-431FAIII, RHFE-431WTA, RHFE-556FAIII, RHFE-556FTRAI, RHFE-556WTA**

For installations at altitude (greater than 2000 feet), follow the guidelines of the National Fuel Gas Code (NFPA 54) and all applicable local codes.

### **Models 201RFA, 202FTA, 263RFA, 265FTA, 433RFA, 433WRTA, 434FTA, 558RFA, 558WRTA, 559FTA, 1004FA, 1004RFA, 1004FTA**

Conversion of the appliance for operation at high altitudes (> 2000 ft, 610 m) requires the completion of the section, *Adjust Gas Pressure Settings*, using the high altitude manifold test pressures. No parts need to be replaced for high altitude.

### **Canada**

For high altitude installations in Canada, the conversion shall be carried out by a manufacturer's authorized representative, in accordance with the requirements of the manufacturer, provincial or territorial authorities having jurisdiction and in accordance with the requirements of CAN/CGA-B149.1 or CAN/CGA-B149 installation codes.

1. Turn off the gas and the power supply.
2. Hold both ends of the bottom cover (undercover assembly) and pull toward you to remove the cover. Cover snaps in place.
3. Remove the 7 screws that hold the front panel and the louver assembly to remove panel from the unit. Pull the panel out at the bottom about 4 inches (100 mm) and lift up over clips that hold it in place at the unit's top.
4. Remove two test point screws (1/8 NPT tap) with 3/16 Allen wrench and attach the manometer to both test ports. Both ports must be used in order to measure the differential pressure. Ensure that the manometer is properly calibrated.
5. Turn on the gas and power supply to the appliance. With the unit in the Off position, press the SW1 switch at the top of PC board until it beeps.
6. Select the correct code for gas type and altitude using ▲ and ▼ buttons:

**NOTE:** Some PC Boards (before version ED-263 -V6-E4) will have only L1, L2, A1, and A2 codes. On these boards L2 and A2 are for altitudes above 2000 ft (610 m). See the figure to locate the label indicating the version.

- L1: Propane gas below 2000 ft (610 m)**
- L2: Propane gas 2001-4500 ft (610-1372 m)**
- L3: Propane gas 4501-7800 ft (1372-2377 m)**
- L4: Propane gas 7801-10200 ft (2378-3109 m)**
- A1: Natural gas below 2000 ft (610 m)**
- A2: Natural gas 2001-4500 ft (610-1372 m)**
- A3: Natural gas 4501-7800 ft (1372-2377 m)**
- A4: Natural gas 7801-10200 ft (2378-3109 m)**

**⚠ CAUTION ⚡**

Do not touch any other areas on the PC board besides the "SW" switches while power is supplied to the appliance. Parts of the PC board are supplied with 120 volts AC.

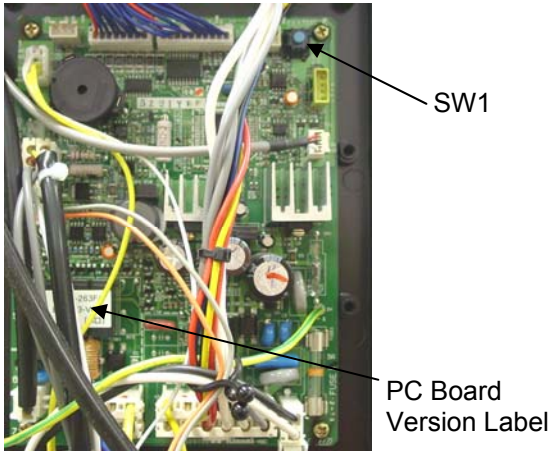
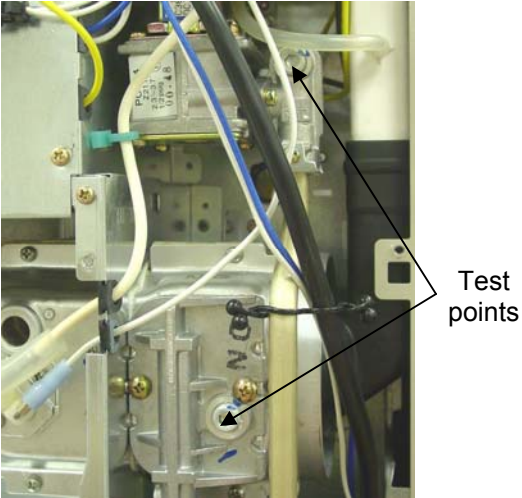

Model	Altitude	Gas Type	High Fire	Low Fire
201FA	0 - 10,200 ft (610 - 3109 m)	Natural Gas	3.3 in (85 mm)	0.6 in (16 mm)
		Propane	6.0 in (152 mm)	0.9 in (24 mm)



Model	Altitude	Gas Type	High Fire	Low Fire
263FA	Less than 2000 ft (610 m)	Natural Gas	2.3 in (58 mm)	0.6 in (16 mm)
		Propane	3.7 in (94 mm)	1.1 in (27 mm)
263FAII	2000 - 10,200 ft (610 - 3109 m)	Natural Gas	1.7 in (42 mm)	0.6 in (16 mm)
		Propane	2.7 in (68 mm)	1.1 in (27 mm)



7. Press the SW1 test button to record the gas type code into memory. The LED will display "F1". If not shown, use the ▲ and ▼ buttons to obtain "F1".
8. Press the SW1 switch to enter this code into memory.
9. The LED will display the temperature scale. Use the ▲ and ▼ buttons to select the Fahrenheit or Celsius scale.
10. Press the SW1 switch for more than 2 seconds to enter the temperature scale into memory.

**The LED display turns blank and the unit returns to the normal off mode. While programming the correct low fire and high fire gas pressure settings, do not adjust gas pressure on this appliance using the screw on top of the gas valve.**

11. Press the ON/OFF button to operate the appliance.

**CAUTION**  

Do not touch the areas at or near the exhaust. These areas become very hot and could cause burns.

12. Press the SW1 switch. The LED will display "78".
13. Press the SW1 switch again to change to the low pressure mode. The LED will display "PL".
14. Compare the pressure reading on the manometer to the desired manifold test pressure (low) for your gas type and altitude. If necessary adjust the low fire pressure using the ▲ and ▼ buttons. Press the SW1 switch to record into memory.
15. The LED will display "PH" indicating high fire mode.
16. Compare the pressure reading on the manometer to the desired manifold test pressure (high) for your gas type and altitude. If necessary adjust the high fire pressure using the ▲ and ▼ buttons. Press the SW1 switch to record into memory.
17. Press the SW1 switch 2 times. After pushing the SW1 switch 2 times, the LED display will display "78". If the LED shows any thing other than "78" call Rinnai Technical Support at 1-800-621-9419 for assistance.
18. Press the ON/OFF button again. The LED display turns blank and the appliance returns to the normal OFF mode.

19. Remove manometer and install Allen head screws. Operate the unit and
  - check the normal operating sequence
  - visually inspect the flame
  - check for gas leaks at the test points

## Normal Operating Sequence

When you press the ON/OFF button, the LED display will illuminate, the combustion fan will begin to run, and the spark will ignite the main burner.

This heater has an automatic ignition system. When the main burner has lit, the combustion lamp will glow red, and the spark will stop.

## Visual Inspection of Flame

Check that the burner flames are operating normally. The flame can be seen through the circular window through the louvers.

When operating normally the burner flame should appear as long, clear, blue, stable, streaks. Yellow flames or an orange color is abnormal and maintenance is required.

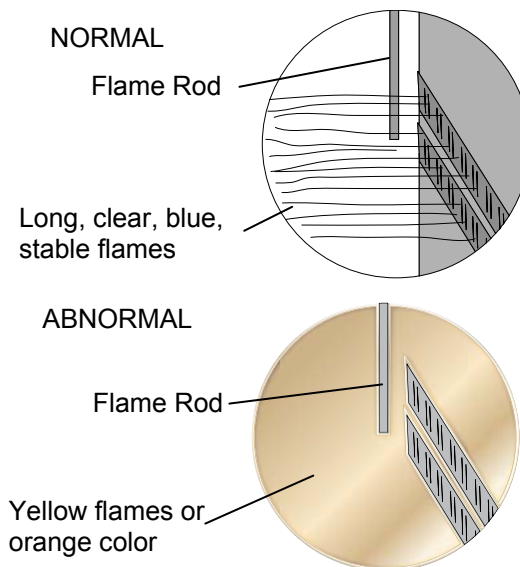

## Final Assembly

Install the front panel and bottom cover.

**Adjust Gas Pressure Settings**

1. Turn off the gas and the power supply.
2. Hold both ends of the bottom cover (undercover assembly) and pull toward you to remove the cover. Cover snaps in place.
3. Remove the 7 screws that hold the front panel and the louver assembly to remove panel from the unit. Pull the panel out at the bottom about 4 inches (100 mm) and lift up over clips that hold it in place at the unit's top.
4. Remove two test point screws (1/8 NPT tap) with 3/16 Allen wrench and attach the manometer to both test ports. Both ports must be used in order to measure the differential pressure. Ensure that the manometer is properly calibrated.
5. Turn on the gas and power supply to the appliance. With the unit in the Off position, press the SW1 switch at the top of PC board until it beeps.
6. Select the correct code for gas type and altitude using ▲ and ▼ buttons:

- L1: Propane gas below 2000 ft (610 m)**
- L2: Propane gas 2001-5200 ft (610-1585 m)**
- L3: Propane gas 5201-7700 ft (1585-2347 m)**
- L4: Propane gas 7701-10200 ft (2348-3109 m)**
- A1: Natural gas below 2000 ft (610 m)**
- A2: Natural gas 2001-5200 ft (610-1585 m)**
- A3: Natural gas 5201-7700 ft (1585-2347 m)**
- A4: Natural gas 7701-10200 ft (2348-3109 m)**

7. Press the SW1 test button to record the gas type code into memory. The LED will display "F1". If not shown, use the ▲ and ▼ buttons to obtain "F1".
8. Press the SW1 switch to enter this code into memory.
9. The LED will display the temperature scale. Use the ▲ and ▼ buttons to select the Fahrenheit or Celsius scale.
10. Press the SW1 switch to enter the temperature scale into memory.

**CAUTION** ⚡  
Do not touch any other areas on the PC board besides the "SW" switches while power is supplied to the appliance. Parts of the PC board are supplied with 120 volts AC.

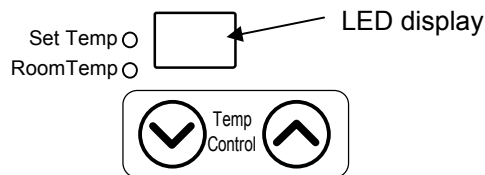
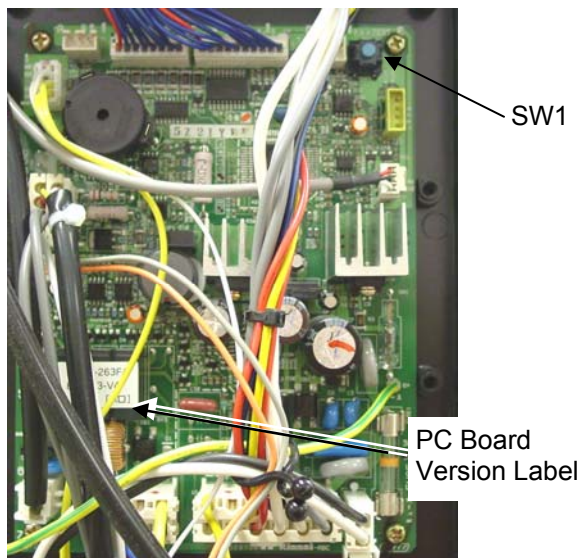
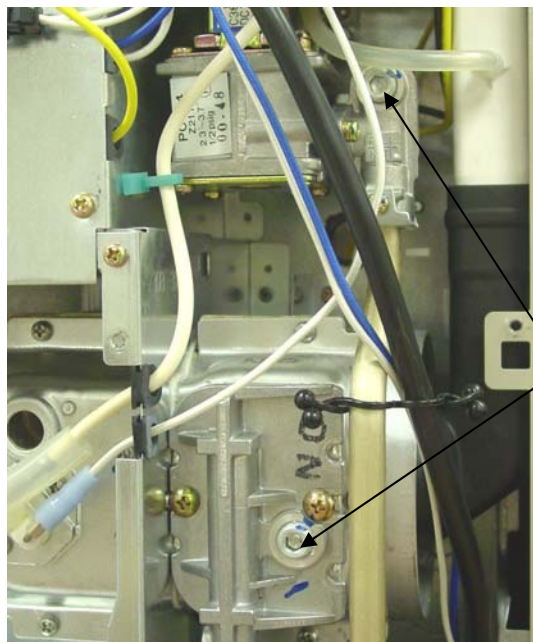

The LED display turns blank and the unit returns to the normal off mode. While programming the correct low fire and high fire gas pressure settings, do not adjust gas pressure on this appliance using the screw on top of the gas valve.

11. Press the ON/OFF button to operate the appliance.

**CAUTION** 

Do not touch the areas at or near the exhaust. These areas become very hot and could cause burns.

12. Press the SW1 switch. The LED will display “78”.
13. Press the SW1 switch again to change to the low pressure mode. The LED will display “PL”.
14. Compare the pressure reading on the manometer to the desired manifold test pressure (low) for your gas type and altitude. If necessary adjust the low fire pressure using the ▲ and ▼ buttons.
15. Press the Economy button to record into memory. The LED will display “18”.
16. Press the SW1 switch twice. The LED will display “PH” indicating high fire mode.
17. Compare the pressure reading on the manometer to the desired manifold test pressure (high) for your gas type and altitude. If necessary adjust the high fire pressure using the ▲ and ▼ buttons.
18. Press the Economy button to record into memory. The LED will display “78”.
19. Press the ON/OFF button again. The LED display turns blank and the appliance returns to the normal OFF mode.
20. Remove manometer and install Allen head screws. Operate the unit and
  - check the normal operating sequence
  - visually inspect the flame
  - check for gas leaks at the test points

**Normal Operating Sequence**

When you press the ON/OFF button, the LED display will illuminate, the combustion fan will begin to run, and the spark will ignite the main burner.

This heater has an automatic ignition system. When the main burner has lit, the combustion lamp will glow red, and the spark will stop.

**Visual Inspection of Flame**

Check that the burner flames are operating normally. The flame can be seen through the circular window through the louvers.

When operating normally the burner flame should appear as long, clear, blue, stable, streaks. Yellow flames or an orange color is abnormal and maintenance is required.

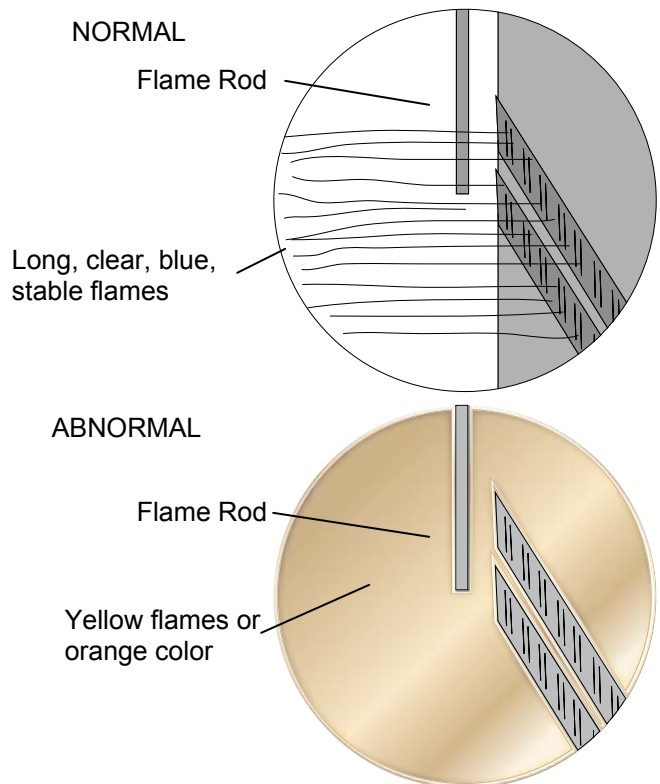

**Final Assembly**

1. Install the front panel and bottom cover.
2. Place the conversion plate (label) on the front cover.

<b>RHFE-201RFA</b>		
	<b>Natural Gas</b>	<b>Propane Gas</b>
Manifold test pressure (Low) - below 2000 ft (610 m)	0.59 in (15 mm) W.C	0.94 in (24 mm) W.C.
Manifold test pressure (Low) - 2001-5200 ft (610-1585 m)	0.59 in (15 mm) W.C	1.14 in (29 mm) W.C.
Manifold test pressure (Low) - above 5200 ft (1585 m)	0.79 in (20 mm) W.C	1.14 in (29 mm) W.C.
Manifold test pressure (High) - for all altitudes	3.3 in (85 mm) W.C.	6.0 in (152 mm) W.C.

<b>RHFE-263RFA</b>		
	<b>Natural Gas</b>	<b>Propane Gas</b>
Manifold test pressure (Low) - below 5200 ft (1585 m)	0.63 in (16 mm) W.C	1.06 in (27 mm) W.C.
Manifold test pressure (Low) - 5201-7700 ft (1585-2347 m)	0.79 in (20 mm) W.C	1.06 in (27 mm) W.C.
Manifold test pressure (Low) - above 7700 ft (2347 m)	0.79 in (20 mm) W.C	1.30 in (33 mm) W.C.
Manifold test pressure (High) - below 2000 ft	2.3 in (58 mm) W.C.	3.7 in (94 mm) W.C.
Manifold test pressure (High) - above 2000 ft	1.7 in (42 mm) W.C.	2.7 in (68 mm) W.C.

**CAUTION** ⚡  
Do not touch any other areas on the PC board besides the switches while power is supplied to the appliance. Parts of the PC board are supplied with 120 volts AC.

**CAUTION** 🔥  
Do not touch the areas at or near the exhaust. These areas become very hot and could cause burns.

1. Turn off the gas and the power supply.
2. Remove the 5 screws that hold the louver assembly and front panel. Lift the panel straight up and then remove it.
3. Remove two pressure point screws (1/8 NPT tap) with 3/16 Allen wrench and attach the manometer to both pressure points. Both pressure points must be used in order to measure the differential pressure. Ensure that the manometer is properly calibrated.
4. Turn on the gas and power supply to the appliance. (Press the “Set back” button after turning on the power supply.) With the unit in the off position, press the test switch at the top of PC board until it beeps.
5. Select the correct code for gas type and altitude using ▲ and ▼ buttons. Refer to the table below.

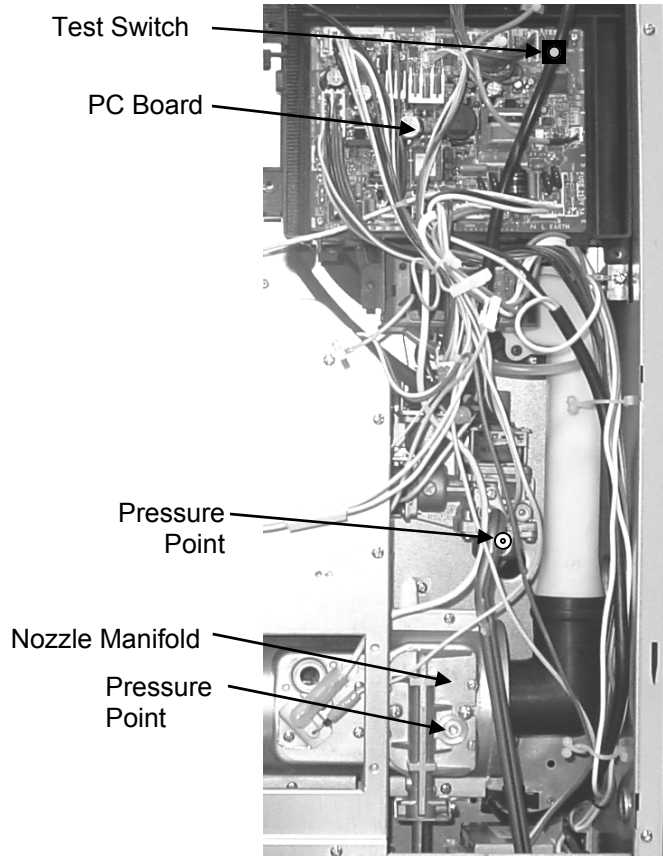

	Natural Gas				Propane Gas			
Code	A1 / A5 *	A2 / A6 *	A3 / A7 *	A4 / A8 *	L1 / L5	L2 / L6	L3 / L7	L4 / L8
Altitude	0-2000 ft 0-610 m	2001-5200 ft 611-1585 m	5201-7700 ft 1586-2347 m	7701-10200 ft 2348-3109 m	0-2000 ft 0-610 m	2001-5200 ft 611-1585 m	5201-7700 ft 1586-2347 m	7701-10200 ft 2348-3109 m
<b>EX08C</b>								
Manifold test pressure - W.C. <b>Low</b>	0.58 in (15 mm)	0.62 in (16 mm)	0.70 in (18 mm)	0.78 in (20 mm)	0.86 in (22 mm)	0.92 in (24 mm)	1.04 in (27 mm)	1.16 in (29 mm)
Manifold test pressure - W.C. <b>High</b>	3.4 in (86 mm)	3.6 in (92 mm)	4.1 in (103 mm)	3.2 in (82 mm)	5.8 in (147 mm)	6.2 in (158 mm)	7.0 in (177 mm)	5.5 in (140 mm)
<b>EX11C</b>								
Manifold test pressure - W.C. <b>Low</b>	0.60 in (15 mm)	0.64 in (16 mm)	0.72 in (19 mm)	0.80 in (20 mm)	1.06 in (27 mm)	1.16 in (29 mm)	1.28 in (33 mm)	1.41 in (36 mm)
Manifold test pressure - W.C. <b>High</b>	2.2 in (56 mm)	1.9 in (49 mm)	1.7 in (44 mm)	1.6 in (40 mm)	3.8 in (95 mm)	3.3 in (84 mm)	3.0 in (75 mm)	2.7 in (69 mm)

\* For the EX11C with natural gas: Use A1, A2, A3, or A4 for venting up to 7 feet (2.1 m) with one elbow. Use A5, A6, A7, or A8 for venting exceeding 7 feet (2.1 m) with one elbow.

6. Press the test switch twice to record the gas type code into memory. .
7. Press the ON/OFF button to operate the appliance.
8. Press the test switch twice. The LED will display "PL".
9. Compare the pressure reading on the manometer to the desired manifold test pressure (low) for your gas type and altitude. If necessary adjust the low fire pressure using the ▲ and ▼ buttons.
10. Press the test switch. The LED will display "PH" indicating high fire mode.
11. Compare the pressure reading on the manometer to the desired manifold test pressure (high) for your gas type and altitude. If necessary adjust the high fire pressure using the ▲ and ▼ buttons.
12. Press the ON/OFF button again. The LED display turns blank and the appliance returns to the normal OFF mode.
13. Remove manometer and install Allen head screws. Operate the unit and
  - check the normal operating sequence
  - visually inspect the flame
  - check for gas leaks at the test points

**Normal Operating Sequence**

When you press the ON/OFF button, the LED display will illuminate, the combustion fan will begin to run, and the spark will ignite the main burner.

This heater has an automatic ignition system. When the main burner has lit, the combustion lamp will glow red, and the spark will stop.

**Visual Inspection of Flame**

Check that the burner flames are operating normally. The flame can be seen through the circular window through the louvers.

When operating normally the burner flame should appear as long, clear, blue, stable, streaks. Yellow flames or an orange color is abnormal and maintenance is required.

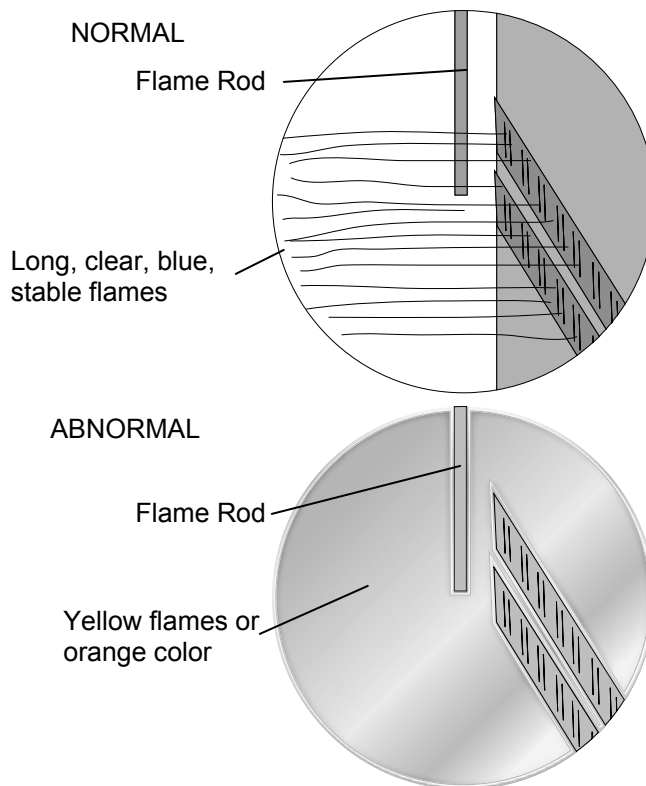

**Final Assembly**

1. Install the front panel and bottom cover.
2. If doing a gas type conversion, place the new conversion plate (label) on the front cover.

**CAUTION**

When attaching the front panel, do not clip or pinch any of the electrical wires in order to prevent any electrical shock.

1. There are two test points, one on the manifold and one on the gas control assembly. Connect the pressure gauge to both test points. Using an electronic manometer, connect the negative side to the manifold test point.
2. Press the ON/OFF switch. After unit ignites, wait approximately one minute.
3. Press the (SW5) button to start the programming mode.
4. Press the (SW4) button. Use the arrow buttons to set the low pressure to the appropriate setting for your model and gas type. The V button will decrease the pressure each time the button is pushed. The W button increases the pressure each time it is pushed.
5. Press the (SW4) button to lock in the low pressure.
6. Press the (SW3) button. Use the arrow buttons to set the high pressure to the appropriate setting for your model and gas type. The ▼ button will decrease the pressure each time the button is pushed. The ▲ button increases the pressure each time it is pushed.
7. Press the (SW3) button to lock in the high pressure.
8. Press the (SW5) button to exit the programming mode and return the appliance to its normal operating mode.
9. Press the ON/OFF button to turn the appliance off.
10. Remove manometer and install the test point screws. Operate the unit and
  - check the normal operating sequence
  - visually inspect the flame
  - check for gas leaks at the test points

## Normal Operating Sequence

When you press the ON/OFF button, the LED display will illuminate, the combustion fan will begin to run, and the spark will ignite the main burner.

This heater has an automatic ignition system. When the main burner has lit, the combustion lamp will glow red, and the spark will stop.

### ⚠ CAUTION ⚡

Do not touch any other areas on the PC board besides the "SW" switches while power is supplied to the appliance. Parts of the PC board are supplied with 120 volts.

### ⚠ CAUTION ☹

Do not touch the areas at or near the heat exchanger or burner. These areas become very hot and could cause burns.

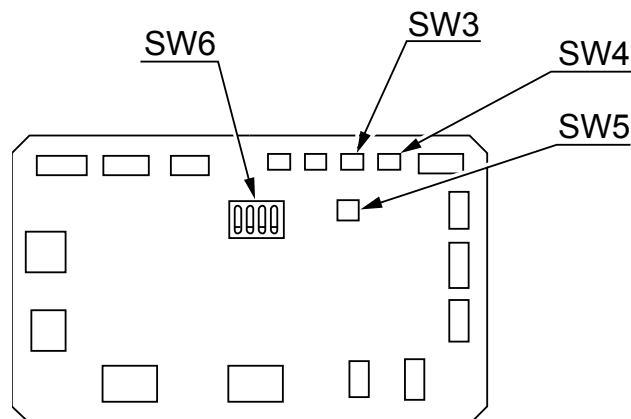
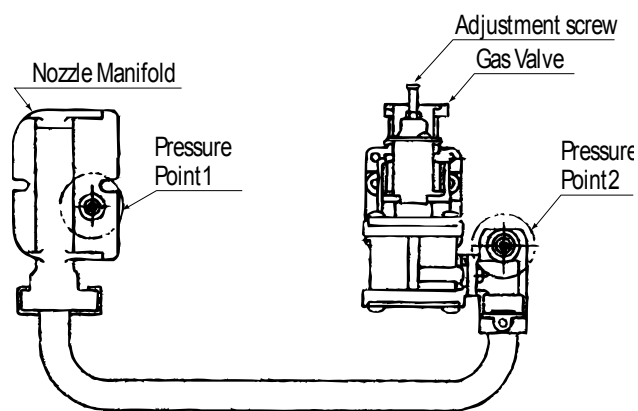

Model	Gas Type	High Fire	Low Fire
431 Series *	Natural Gas	2.4 in (61 mm)	0.7 in (18 mm)
	Propane	2.8 in (71 mm)	0.8 in (20 mm)
556 Series *	Natural Gas	3.8 in (97 mm)	0.7 in (18 mm)
	Propane	4.5 in (114 mm)	0.8 in (20 mm)

\* For installations at altitude (greater than 2000 feet), follow the guidelines of the National Fuel Gas Code (NFPA 54) and all applicable local codes.

### Visual Inspection of Flame

Check that the burner flames are operating normally. The flame can be seen through the circular window through the louvers.

When operating normally the burner flame should appear as long, clear, blue, stable, streaks. Yellow flames or an orange color is abnormal and maintenance is required.

### Final Assembly

Install the front panel and bottom cover.

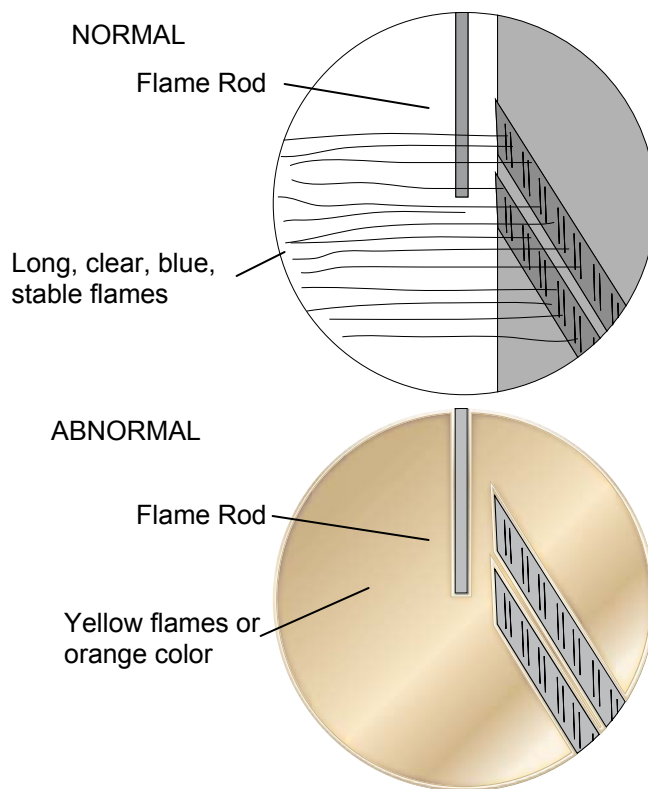



**CAUTION** ⚡  
Do not touch any other areas on the PC board besides the switches while power is supplied to the appliance. Parts of the PC board are supplied with 120 volts AC.

**CAUTION** 🔥  
Do not touch the areas at or near the exhaust. These areas become very hot and could cause burns.

1. Turn off the gas and the power supply.
2. Hold both ends of the bottom cover (undercover assembly) and pull toward you to remove the cover. Cover snaps in place.
3. Remove the 6 screws that hold the louver assembly and 2 screws at the bottom of the front panel to remove panel from the unit. Pull the panel out at the bottom about 4 inches (100 mm) and lift up over clips that hold it in place at the unit's top.
4. Remove two test point screws (1/8 NPT tap) with 3/16 Allen wrench and attach the manometer to both test ports. Both ports must be used in order to measure the differential pressure. Ensure that the manometer is properly calibrated.
5. Turn on the gas and power supply to the appliance. With the unit in the Off position, press the SW1 switch at the top of PC board until it beeps.
6. Select the correct code for gas type and altitude using ▲ and ▼ buttons:

**L1: Propane gas below 2000 ft (610 m)**

**L2: Propane gas 2001-5200 ft (611-1585 m)**

**L3: Propane gas 5201-7700 ft (1586-2347 m)**

**L4: Propane gas 7701-10200 ft (2348-3109 m)**

**A1: Natural gas below 2000 ft (610 m)**

**A2: Natural gas 2001-5200 ft (611-1585 m)**

**A3: Natural gas 5201-7700 ft (1586-2347 m)**

**A4: Natural gas 7701-10200 ft (2348-3109 m)**

7. Press the SW1 test button to record the gas type code into memory. The LED will display "F1". If not shown, use the ▲ and ▼ buttons to obtain "F1".

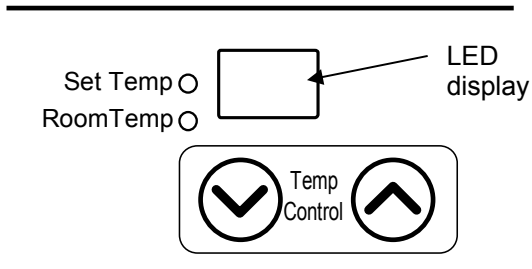
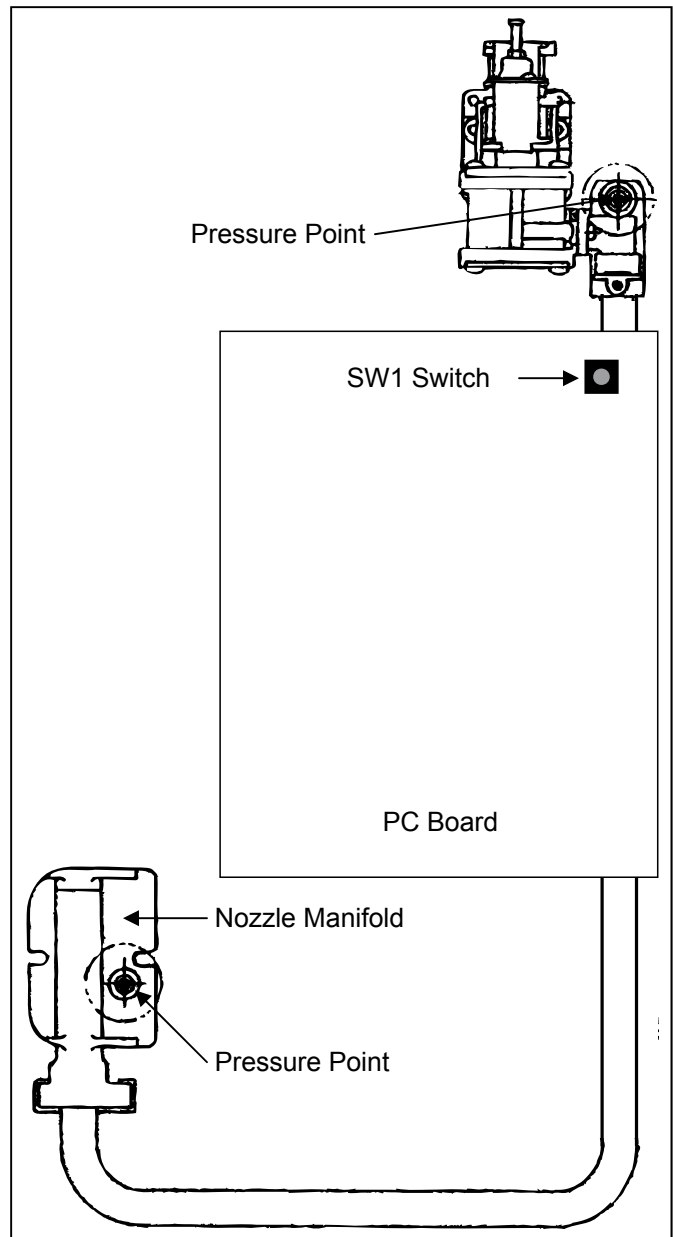

8. Press the SW1 switch to enter this code into memory.
9. The LED will display the temperature scale. Use the ▲ and ▼ buttons to select the Fahrenheit or Celsius scale.
10. Press the SW1 switch to enter the temperature scale into memory.

**The LED display turns blank and the unit returns to the normal off mode. While programming the correct low fire and high fire gas pressure settings, do not adjust gas pressure on this appliance using the screw on top of the gas valve.**

11. Press the ON/OFF button to operate the appliance.
12. Press the SW1 switch. The LED will display "78".
13. Press the SW1 switch again to change to the low pressure mode. The LED will display "PL".
14. Compare the pressure reading on the manometer to the desired manifold test pressure (low) for your gas type and altitude. If necessary adjust the low fire pressure using the ▲ and ▼ buttons.
15. Press the Economy button to record into memory. The LED will display "18".
16. Press the SW1 switch twice. The LED will display "PH" indicating high fire mode.
17. Compare the pressure reading on the manometer to the desired manifold test pressure (high) for your gas type and altitude. If necessary adjust the high fire pressure using the ▲ and ▼ buttons.
18. Press the Economy button to record into memory. The LED will display "78".
19. Press the ON/OFF button again. The LED display turns blank and the appliance returns to the normal OFF mode.
20. Remove manometer and install Allen head screws. Operate the unit and
  - check the normal operating sequence
  - visually inspect the flame
  - check for gas leaks at the test points

## Normal Operating Sequence

When you press the ON/OFF button, the LED display will illuminate, the combustion fan will begin to run, and the spark will ignite the main burner.

This heater has an automatic ignition system. When the main burner has lit, the combustion lamp will glow red, and the spark will stop.

## Visual Inspection of Flame

Check that the burner flames are operating normally. The flame can be seen through the circular window through the louvers.

When operating normally the burner flame should appear as long, clear, blue, stable, streaks. Yellow flames or an orange color is abnormal and maintenance is required.

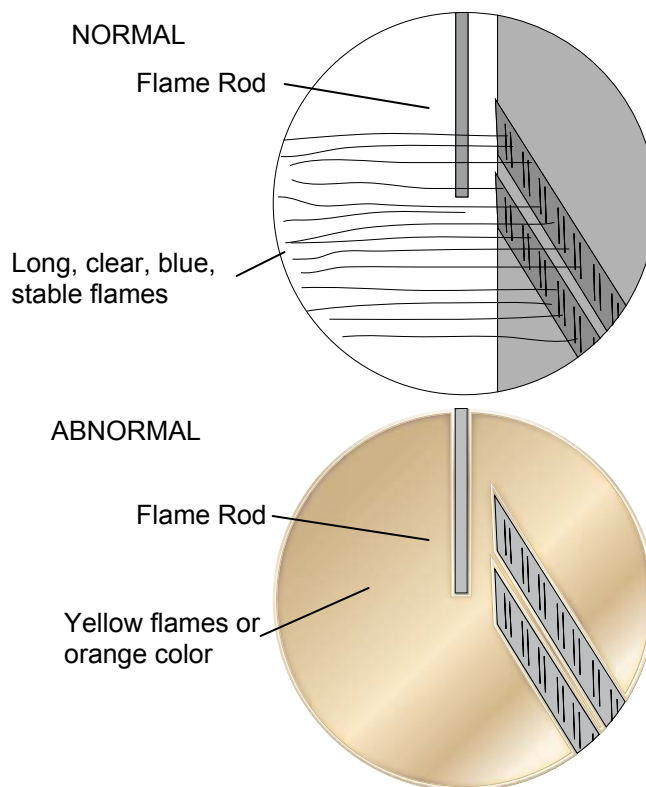

## Final Assembly

1. Install the front panel and bottom cover.
2. Place the conversion plate (label) on the front cover.

	Natural Gas				Propane Gas			
Code	A1	A2	A3	A4	L1	L2	L3	L4
Altitude	0-2000 ft 0-610 m	2001-5200 ft 611-1585 m	5201-7700 ft 1586-2347 m	7701-10200 ft 2348-3109 m	0-2000 ft 0-610 m	2001-5200 ft 611-1585 m	5201-7700 ft 1586-2347 m	7701-10200 ft 2348-3109 m
<b>ES17</b>								
Manifold test pressure - W.C. <b>Low</b>	0.40 in (10 mm)	0.44 in (11 mm)	0.48 in (12 mm)	0.52 in (13 mm)	0.72 in (18 mm)	0.76 in (19 mm)	0.88 in (22 mm)	0.96 in (24 mm)
Manifold test pressure - W.C. <b>High</b>	1.6 in (40 mm)	1.4 in (35 mm)	1.2 in (32 mm)	1.1 in (29 mm)	2.9 in (72 mm)	2.5 in (63 mm)	2.2 in (57 mm)	2.0 in (52 mm)
<b>ES22</b>								
Manifold test pressure - W.C. <b>Low</b>	0.40 in (10 mm)	0.44 in (11 mm)	0.48 in (12 mm)	0.52 in (13 mm)	0.72 in (18 mm)	0.76 in (19 mm)	0.88 in (22 mm)	0.96 in (24 mm)
Manifold test pressure - W.C. <b>High</b>	2.6 in (65 mm)	2.2 in (57 mm)	2.0 in (52 mm)	1.8 in (47 mm)	4.3 in (110 mm)	3.8 in (97 mm)	3.4 in (87 mm)	3.1 in (80 mm)

**CAUTION** ⚡  
Do not touch any other areas on the PC board besides the switches while power is supplied to the appliance. Parts of the PC board are supplied with 120 volts AC.

**CAUTION** ☹️  
Do not touch the areas at or near the exhaust. These areas become very hot and could cause burns.

1. Turn off the gas and the power supply.
2. Hold both ends of the bottom cover (undercover assembly) and pull toward you to remove the cover. Cover snaps in place.
3. Remove the 6 screws that hold the louver assembly and 2 screws at the bottom of the front panel to remove panel from the unit. Pull the panel out at the bottom about 4 inches (100 mm) and lift up over clips that hold it in place at the unit's top.
4. Adjust the dip switch positions for your altitude, gas type, model, and temperature scale. (Refer to the table below.)
5. Remove two test point screws (1/8 NPT tap) with 3/16 Allen wrench and attach the manometer to both test ports. Both ports must be used in order to measure the differential pressure. Ensure that the manometer is properly calibrated.
6. Turn on the gas and power supply to the appliance.
7. Press the ON/OFF button to operate the appliance.
8. Press the TEST switch at the right of PC board.
9. Press the PL switch to adjust the low fire test pressure

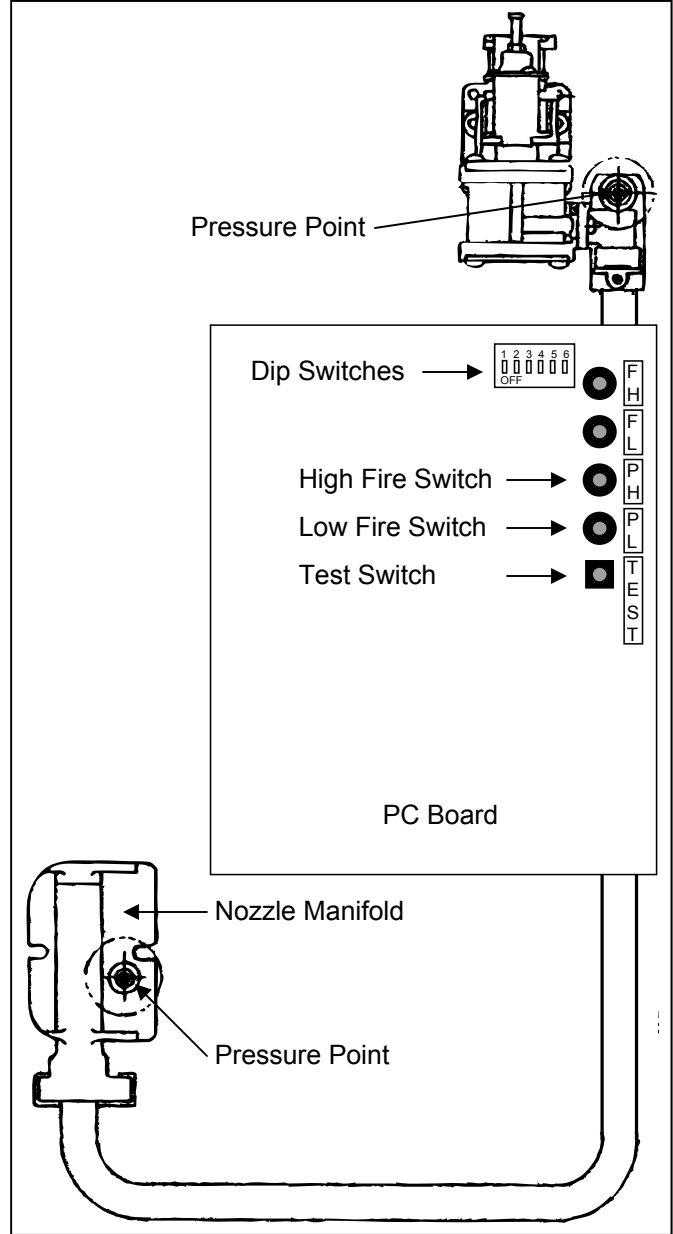

### Dip Switch Positions

Altitude	Gas Type	1	2	3	4	5	6
0-2000 ft (0-610 m)	Natural Gas	OFF	OFF	OFF	OFF	ON for EX17  OFF for EX22	ON for Celsius  OFF for Fahrenheit
	Propane	ON	ON	ON			
2001-5200 ft (611-1585 m)	Natural Gas	ON	OFF	OFF			
	Propane	OFF	ON	ON			
5201-7700 ft (1586-2347 m)	Natural Gas	OFF	ON	OFF			
	Propane	ON	OFF	ON			
(7701-10200 ft) (2348-3109 m)	Natural Gas	OFF	OFF	ON			
	Propane	ON	ON	OFF			

10. Compare the pressure reading on the manometer to the desired manifold test pressure (low) for your gas type and altitude. If necessary adjust the low fire pressure using the ▲ and ▼ buttons.
11. After adjusting the low fire pressure, press the PL switch.
12. Press the PH switch to adjust the high fire pressure.
13. Compare the pressure reading on the manometer to the desired manifold test pressure (high) for your gas type and altitude. If necessary adjust the low fire pressure using the ▲ and ▼ buttons.
14. After adjusting the high fire pressure, press the PH switch.
15. Press the ON/OFF button again. The LED display turns blank and the appliance returns to the normal OFF mode.
16. Remove manometer and install Allen head screws. Operate the unit and
  - check the normal operating sequence
  - visually inspect the flame
  - check for gas leaks at the test points

### Normal Operating Sequence

When you press the ON/OFF button, the LED display will illuminate, the combustion fan will begin to run, and the spark will ignite the main burner.

This heater has an automatic ignition system. When the main burner has lit, the combustion lamp will glow red, and the spark will stop.

### Visual Inspection of Flame

Check that the burner flames are operating normally. The flame can be seen through the circular window through the louvers.

When operating normally the burner flame should appear as long, clear, blue, stable, streaks. Yellow flames or an orange color is abnormal and maintenance is required.

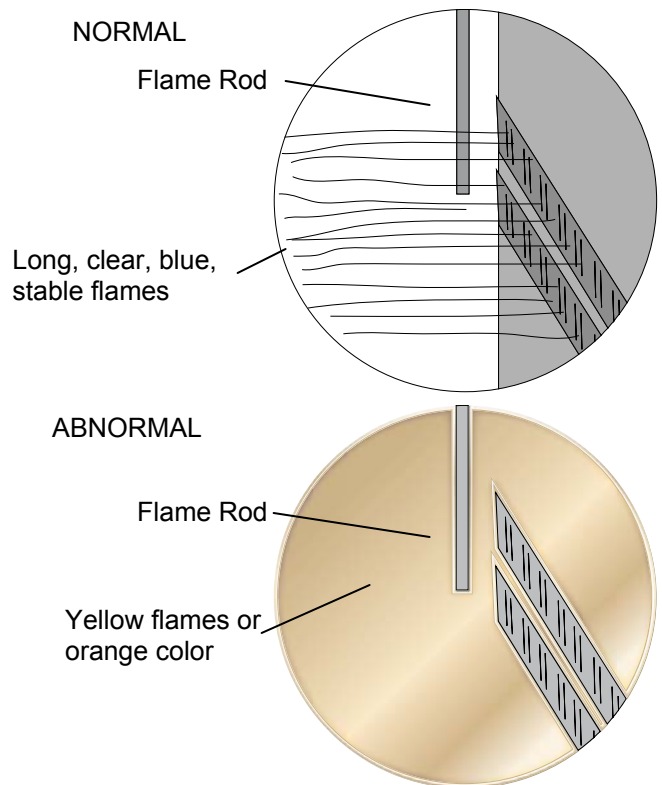

### Final Assembly

1. Install the front panel and bottom cover.
2. Place the conversion plate (label) on the front cover.

	Natural Gas				Propane Gas			
Code	A1	A2	A3	A4	L1	L2	L3	L4
Altitude	0-2000 ft 0-610 m	2001-5200 ft 611-1585 m	5201-7700 ft 1586-2347 m	7701-10200 ft 2348-3109 m	0-2000 ft 0-610 m	2001-5200 ft 611-1585 m	5201-7700 ft 1586-2347 m	7701-10200 ft 2348-3109 m
<b>EX17</b>								
Manifold test pressure - W.C. <b>Low</b>	0.40 in (10 mm)	0.44 in (11 mm)	0.48 in (12 mm)	0.52 in (13 mm)	0.72 in (18 mm)	0.76 in (19 mm)	0.88 in (22 mm)	0.96 in (24 mm)
Manifold test pressure - W.C. <b>High</b>	1.6 in (40 mm)	1.4 in (35 mm)	1.2 in (32 mm)	1.1 in (29 mm)	2.9 in (72 mm)	2.5 in (63 mm)	2.2 in (57 mm)	2.0 in (52 mm)
<b>ES22</b>								
Manifold test pressure - W.C. <b>Low</b>	0.40 in (10 mm)	0.44 in (11 mm)	0.48 in (12 mm)	0.52 in (13 mm)	0.72 in (18 mm)	0.76 in (19 mm)	0.88 in (22 mm)	0.96 in (24 mm)
Manifold test pressure - W.C. <b>High</b>	2.6 in (65 mm)	2.2 in (57 mm)	2.0 in (52 mm)	1.8 in (47 mm)	4.3 in (110 mm)	3.8 in (97 mm)	3.4 in (87 mm)	3.1 in (80 mm)

**CAUTION** ⚡  
Do not touch any other areas on the PC board besides the switches while power is supplied to the appliance. Parts of the PC board are supplied with 120 volts AC.

**CAUTION** 🔥  
Do not touch the areas at or near the exhaust. These areas become very hot and could cause burns.

1. Turn off the gas and the power supply.
2. Remove the 5 screws that hold the louver assembly and front panel. Lift the panel straight up and then remove it.
3. Remove two pressure point screws (1/8 NPT tap) with 3/16 Allen wrench and attach the manometer to both pressure points. Both pressure points must be used in order to measure the differential pressure. Ensure that the manometer is properly calibrated.
4. Turn on the gas and power supply to the appliance. (Press the "Set back" button after turning on the power supply.) With the unit in the off position, press the test switch at the top of PC board until it beeps.
5. Select the correct code for gas type and altitude using ▲ and ▼ buttons. Refer to the table below.

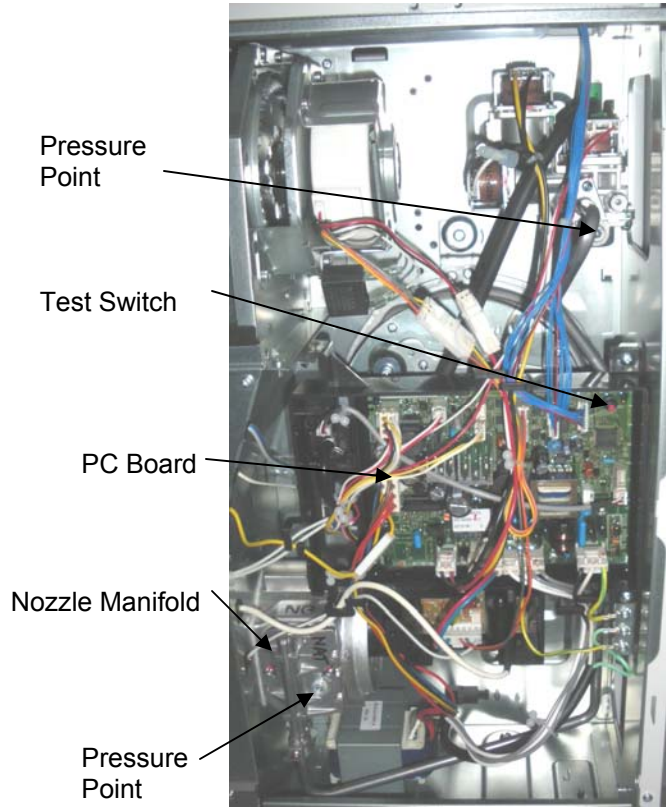

	Natural Gas				Propane Gas			
Code	A1 / A5	A2 / A6	A3 / A7	A4 / A8	L1 / L5	L2 / L6	L3 / L7	L4 / L8
Altitude	0-2000 ft 0-610 m	2001-5200 ft 611-1585 m	5201-7700 ft 1586-2347 m	7701-10200 ft 2348-3109 m	0-2000 ft 0-610 m	2001-5200 ft 611-1585 m	5201-7700 ft 1586-2347 m	7701-10200 ft 2348-3109 m
<b>EX17C</b>								
Manifold test pressure - W.C. <b>Low</b>	0.44 in (11 mm)	0.48 in (12 mm)	0.54 in (14 mm)	0.60 in (15 mm)	0.68 in (17 mm)	0.74 in (19 mm)	0.82 in (21 mm)	0.92 in (23 mm)
Manifold test pressure - W.C. <b>High</b>	1.6 in (40 mm)	1.4 in (35 mm)	1.2 in (32 mm)	1.1 in (29 mm)	2.7 in (69 mm)	2.4 in (61 mm)	2.2 in (55 mm)	2.0 in (50 mm)
<b>EX22C</b>								
Manifold test pressure - W.C. <b>Low</b>	0.44 in (11 mm)	0.48 in (12 mm)	0.54 in (14 mm)	0.60 in (15 mm)	0.68 in (17 mm)	0.74 in (19 mm)	0.82 in (21 mm)	0.92 in (23 mm)
Manifold test pressure - W.C. <b>High</b>	2.6 in (65 mm)	2.2 in (57 mm)	2.0 in (52 mm)	1.8 in (47 mm)	4.0 in (101 mm)	3.5 in (89 mm)	3.1 in (80 mm)	2.9 in (72 mm)

6. Press the test switch twice to record the gas type code into memory. .
7. Press the ON/OFF button to operate the appliance.
8. Press the test switch twice. The LED will display "PL" indicating low fire mode.
9. Compare the pressure reading on the manometer to the desired manifold test pressure (low) for your gas type and altitude. If necessary adjust the low fire pressure using the ▲ and ▼ buttons.
10. Press the test switch. The LED will display "PH" indicating high fire mode.
11. Compare the pressure reading on the manometer to the desired manifold test pressure (high) for your gas type and altitude. If necessary adjust the high fire pressure using the ▲ and ▼ buttons.
12. Press the ON/OFF button again. The LED display turns blank and the appliance returns to the normal OFF mode.
13. Remove manometer and install Allen head screws. Operate the unit and
  - check the normal operating sequence
  - visually inspect the flame
  - check for gas leaks at the test points

## Normal Operating Sequence

When you press the ON/OFF button, the LED display will illuminate, the combustion fan will begin to run, and the spark will ignite the main burner.

This heater has an automatic ignition system. When the main burner has lit, the combustion lamp will glow red, and the spark will stop.

## Visual Inspection of Flame

Check that the burner flames are operating normally. The flame can be seen through the circular window.

When operating normally the burner flame should appear as long, clear, blue, stable, streaks. Yellow flames or an orange color is abnormal and maintenance is required.

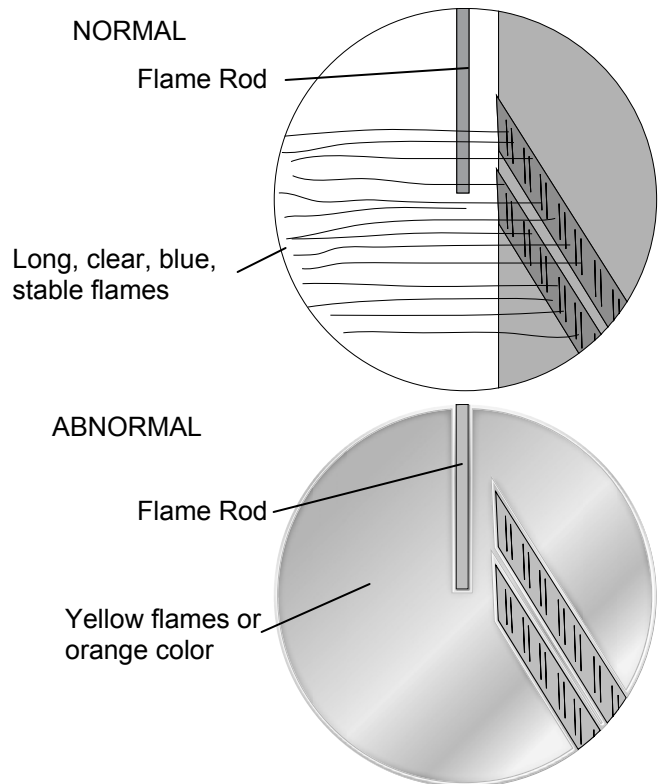

## Final Assembly

1. Install the front panel and bottom cover.
2. If doing a gas type conversion, place the new conversion plate (label) on the front cover.

## CAUTION

When attaching the front panel, do not clip or pinch any of the electrical wires in order to prevent any electrical shock.



## Changing Manifold Pressure Settings

1. Turn off the gas and the power supply.
2. Remove the 2 screws that hold the front panel. Pull the panel out at the top and disconnect the LED wiring harness. Tilt the top out and remove front cover.
3. Remove one test point screw (1/8 NPT tap) with 3/16 Allen wrench and attach the manometer to the test port. Ensure that the manometer is properly calibrated.
4. Turn on the gas and power supply to the appliance. With the unit in the Off position, press the SW1 switch at the top of PC board until it beeps.

5. Select the correct code on the LED display using ▲ and ▼ buttons:

High altitude is above 2000 ft (610 m).

**L1: Propane gas at low (sea level) altitude**

**L2: Propane gas unit at high altitude**

**A1: Natural gas at low (sea level) altitude**

**A2: Natural gas unit at high altitude**

6. Press the SW1 test button to record the gas type code into memory.

**The LED display turns blank and the unit returns to the normal off mode. You are now ready to program in your correct low fire and high fire gas pressure setting. Follow the procedure below for setting the manifold gas pressure. Do not adjust gas pressure on this appliance using the screw on top of the gas valve.**

**⚠ CAUTION ⚡**

Do not touch any other areas on the PC board besides the “SW” switches while power is supplied to the appliance. Parts of the PC board are supplied with 120 volts.

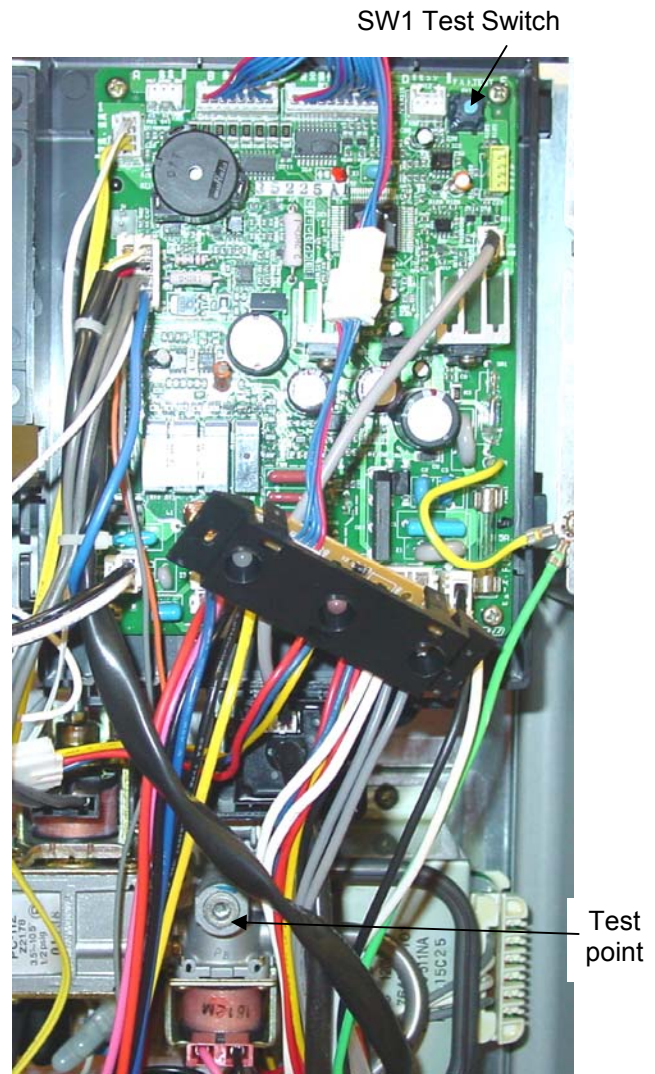

**Table 1 Pressure Setting (W.C.) using Natural Gas**

Altitude	High Fire	Low Fire
Less than 2000 ft (610 m)	3.70 in * (94 mm)	2.0 in * (51 mm)
2000 - 10,200 ft (610 - 3048 m)	2.70 in (69 mm)	2.0 in (51 mm)
* Factory Setting		

**Table 2 Pressure Setting (W.C.) using Propane Gas**

Altitude	High Fire	Low Fire
Less than 2000 ft (610 m)	10.1 in * (257 mm)	4.3 in * (109 mm)
2000 - 10,200 ft (610 - 3048 m)	7.3 in (185 mm)	4.3 in (109 mm)
* Factory Setting		

**CAUTION** 

Do not insert hands or objects into the circulation fans while they are running. Injury or mechanical malfunction may occur.

**CAUTION** 

Do not touch the areas at or near the heat exchanger or burner. These areas become very hot and could cause burns.

7. Press the ON/OFF button to operate the appliance.
8. Press the SW1 switch. The LED will display "78" or "7三".
9. Press the SW1 switch again to change to the low pressure mode. The LED will display "PL".
10. Compare the pressure reading on the manometer to the correct table for your gas type. If necessary adjust the low fire pressure using the ▲ and ▼ buttons.
11. Press the Economy button. The LED will display "18" indicating that the low pressure has been recorded into memory.
12. Press the SW1 switch **TWICE**. This puts the appliance into the high fire mode. The LED will display "PH".
13. Compare the pressure reading on the manometer to the correct table for your gas type. If necessary adjust the high fire pressure using the ▲ and ▼ buttons.
14. Press the Economy button to enter the high fire pressure into memory. The LED display will display "78". If the LED shows any thing other than "78" call Rinnai Technical Support at 1-800-621-9419 for assistance.
15. Press the ON/OFF button again. The LED display turns blank and the appliance returns to the normal OFF mode.
17. Remove manometer and install Allen head screws. Operate the unit and
  - check the normal operating sequence
  - visually inspect the flame
  - check for gas leaks at the test points

### Normal Operating Sequence

When you press the ON/OFF button, the LED display will illuminate, the combustion fan will begin to run, and the spark will ignite the main burner.

This heater has an automatic ignition system. When the main burner has lit, the combustion lamp will glow red, and the spark will stop.

### Visual Inspection of Flame

Check that the burner flames are operating normally. The flame can be seen through the circular window through the louvers.

When operating normally the burner flame should appear as long, clear, blue, stable, streaks. Yellow flames or an orange color is abnormal and maintenance is required.

#### VISUAL CHECK

##### SATISFACTORY

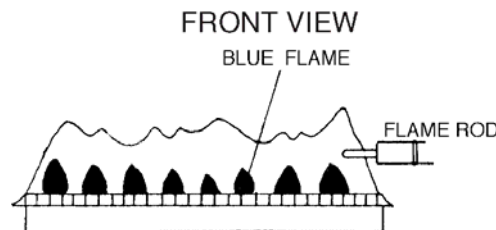

##### UNSATISFACTORY

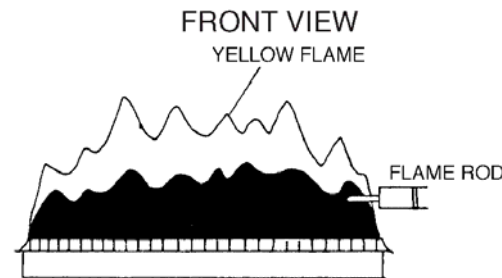

### Final Assembly

Install the front panel and bottom cover.

1. Turn off the gas and the power supply.
2. Remove one test point screw (1/8 NPT tap) with 3/16 Allen wrench and attach the manometer to the test port. Ensure that the manometer is properly calibrated.
3. Turn on the gas and power supply to the appliance. With the unit in the Off position, press the SW1 switch at the top of PC board until it beeps.
4. Select the correct code for gas type and altitude on the LED display using ▲ and ▼ buttons:
  - L1: Propane gas below 2000 ft (610 m)**
  - L2: Propane gas 2001-5200 ft (611-1585 m)**
  - L3: Propane gas 5201-7700 ft (1586-2347 m)**
  - L4: Propane gas 7701-10200 ft (2348-3109 m)**
  - A1: Natural gas below 2000 ft (610 m)**
  - A2: Natural gas 2001-5200 ft (611-1585 m)**
  - A3: Natural gas 5201-7700 ft (1586-2347 m)**
  - A4: Natural gas 7701-10200 ft (2348-3109 m)**
5. Press the SW1 switch to enter the gas code into memory.

**The LED display turns blank and the unit returns to the normal off mode. You are now ready to program in your correct low fire and high fire gas pressure setting. Follow the procedure below for setting the manifold gas pressure. Do not adjust gas pressure on this appliance using the screw on top of the gas valve.**

6. Press the ON/OFF button to operate the appliance.
7. Press the SW1 switch. The LED will display two digits - a "7" and another number.
8. Press the SW1 switch again to change to the low pressure mode. The LED will display "PL".
9. Compare the pressure reading on the manometer to the correct table for your gas type. If necessary adjust the low fire pressure using the ▲ and ▼ buttons. Press the Economy switch to record into memory. Press the SW1 switch twice.
10. The LED will display "PH" indicating high fire mode.
11. Compare the pressure reading on the manometer to the correct table for your gas type. If necessary adjust the high fire pressure using the ▲ and ▼ buttons. Press the Economy switch to record into memory.

**CAUTION**  Do not insert hands or objects into the circulation fans while they are running. Injury or mechanical malfunction may occur.

**CAUTION**  Do not touch any other areas on the PC board besides the "SW" switches while power is supplied to the appliance. Parts of the PC board are supplied with 120 volts AC.

**CAUTION**  Do not touch the areas at or near the exhaust. This area becomes very hot and could cause burns.

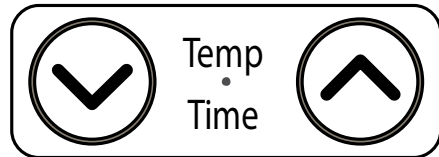
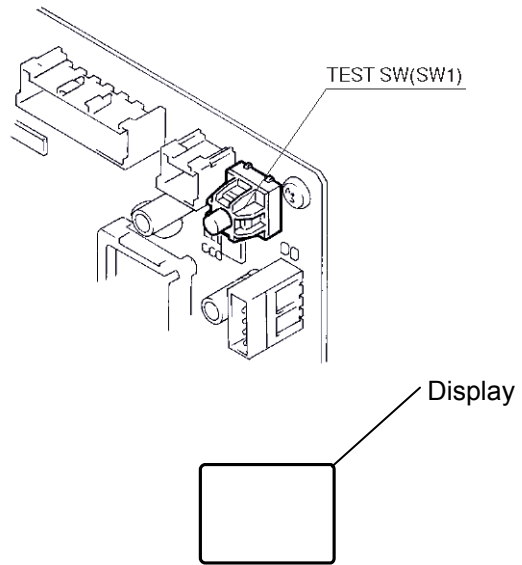

**NOTICE**

The regulator has been factory pre-set. If the pressure is incorrect, check the supply pressure first, before making any adjustments to the appliance. Also, if the low control pressure cannot be obtained, adjust the adjustment screw on the proportional valve to roughly set pressure and then recheck both the low and high fire pressures.

12. The LED will display two digits - a "7" and another number. If the LED shows any thing else call Rinnai Technical Support at 1-800-621-9419 for assistance.
13. Press the ON/OFF button again. The LED display turns blank and the appliance returns to the normal OFF mode.
14. Remove manometer and install Allen head screw. Operate the unit and
  - check the normal operating sequence
  - visually inspect the flame
  - check for gas leaks at the test points

NOTE: If the LED display shows "HF" or "LF" do not touch the ▲ and ▼ buttons or Economy button. In this case push SW1.

**Normal Operating Sequence**

When you press the ON/OFF button, the LED display will illuminate, the combustion fan will begin to run, and the spark will ignite the main burner.

This heater has an automatic ignition system. When the main burner has lit, the combustion lamp will glow red, and the spark will stop.

**Visual Inspection of Flame**

Check that the burner flames are operating normally. The flame can be seen through the circular window through the louvers.

When operating normally the burner flame should appear as long, clear, blue, stable, streaks. Yellow flames or an orange color is abnormal and maintenance is required.

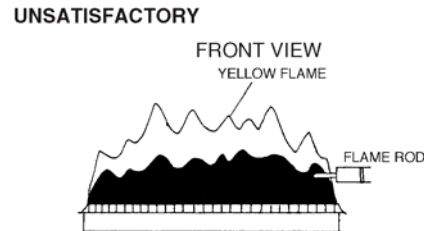
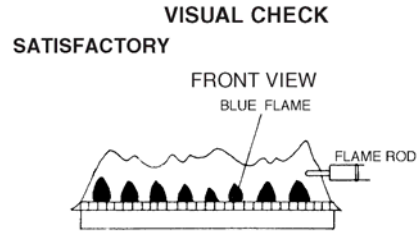

**Final Assembly**

1. Install the front panel and bottom cover.
2. Place the conversion plate (label) on the front cover.

	Natural Gas				Propane Gas			
Code	A1	A2	A3	A4	L1	L2	L3	L4
Altitude	0-2000 ft 0-610 m	2001-5200 ft 611-1585 m	5201-7700 ft 1586-2347 m	7701-10200 ft 2348-3109 m	0-2000 ft 0-610 m	2001-5200 ft 611-1585 m	5201-7700 ft 1586-2347 m	7701-10200 ft 2348-3109 m
Manifold test pressure - W.C. <b>Low</b>	1.97 in (50 mm)	1.97 in (50 mm)	1.97 in (50 mm)	1.97 in (50 mm)	4.29 in (109 mm)	4.29 in (109 mm)	4.29 in (109 mm)	4.29 in (109 mm)
Manifold test pressure - W.C. <b>High</b>	3.7 in (94 mm)	3.3 in (83 mm)	3.0 in (76 mm)	2.8 in (70 mm)	10.1 in (257 mm)	9.1 in (232 mm)	8.3 in (212 mm)	7.6 in (194 mm)

## Dip Switch Settings

---

### RHFE-556WTA

PROPANE

ON	<input checked="" type="checkbox"/>	<input type="checkbox"/>	<input type="checkbox"/>	<input type="checkbox"/>	<input checked="" type="checkbox"/>
OFF	<input type="checkbox"/>	<input checked="" type="checkbox"/>	<input checked="" type="checkbox"/>	<input type="checkbox"/>	<input type="checkbox"/>

NATURAL GAS

ON	<input type="checkbox"/>	<input checked="" type="checkbox"/>	<input type="checkbox"/>	<input type="checkbox"/>	<input checked="" type="checkbox"/>
OFF	<input checked="" type="checkbox"/>	<input type="checkbox"/>	<input checked="" type="checkbox"/>	<input type="checkbox"/>	<input type="checkbox"/>

### RHFE-556FA / FTRA Series

PROPANE

ON	<input checked="" type="checkbox"/>	<input checked="" type="checkbox"/>	<input type="checkbox"/>	<input type="checkbox"/>
OFF	<input type="checkbox"/>	<input type="checkbox"/>	<input checked="" type="checkbox"/>	<input checked="" type="checkbox"/>

NATURAL GAS

ON	<input type="checkbox"/>	<input type="checkbox"/>	<input type="checkbox"/>	<input type="checkbox"/>
OFF	<input checked="" type="checkbox"/>	<input checked="" type="checkbox"/>	<input checked="" type="checkbox"/>	<input checked="" type="checkbox"/>

### RHFE-431FA Series

PROPANE

ON	<input checked="" type="checkbox"/>	<input checked="" type="checkbox"/>	<input checked="" type="checkbox"/>	<input checked="" type="checkbox"/>
OFF	<input type="checkbox"/>	<input type="checkbox"/>	<input type="checkbox"/>	<input type="checkbox"/>

NATURAL GAS

ON	<input type="checkbox"/>	<input type="checkbox"/>	<input checked="" type="checkbox"/>	<input checked="" type="checkbox"/>
OFF	<input checked="" type="checkbox"/>	<input checked="" type="checkbox"/>	<input type="checkbox"/>	<input type="checkbox"/>

### RHFE-431WTA

PROPANE

ON	<input checked="" type="checkbox"/>	<input type="checkbox"/>	<input type="checkbox"/>	<input checked="" type="checkbox"/>	<input checked="" type="checkbox"/>
OFF	<input type="checkbox"/>	<input checked="" type="checkbox"/>	<input checked="" type="checkbox"/>	<input type="checkbox"/>	<input type="checkbox"/>

NATURAL GAS

ON	<input type="checkbox"/>	<input checked="" type="checkbox"/>	<input type="checkbox"/>	<input checked="" type="checkbox"/>	<input checked="" type="checkbox"/>
OFF	<input checked="" type="checkbox"/>	<input type="checkbox"/>	<input checked="" type="checkbox"/>	<input type="checkbox"/>	<input type="checkbox"/>

The models RHFE-201FA, RHFE-263FA Series, RHFE-551FA, RHFE-1001 Series, and RHFE-1004FA do not have dip switches.

## Checking Micro-amps

RHFE 201, 263, 431, 556 Series

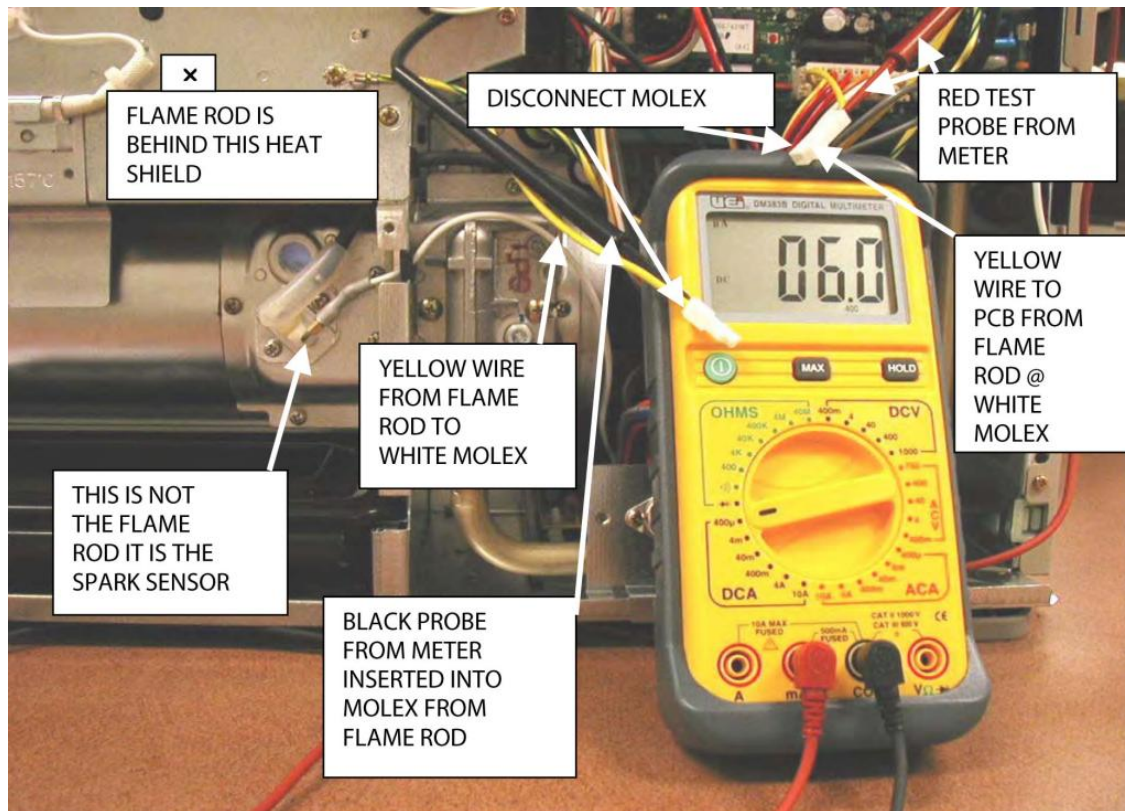

1. Locate the yellow wire from the flame rod. Disconnect at Molex.
2. Set the meter to read micro-amps.
3. Place the meter in series with the flame rod and the disconnected Molex.
4. Operate the appliance and view the flame development in the view window.
5. Read the micro-amps on the meter for high fire and low fire conditions.

NOTE: Volt meters differ in style and configuration. It is the technician's responsibility to know the tools and how to set up for operations and testing.

## Setting up the U Tube Manometer

RHFE 201, 263, 431, 556 Series

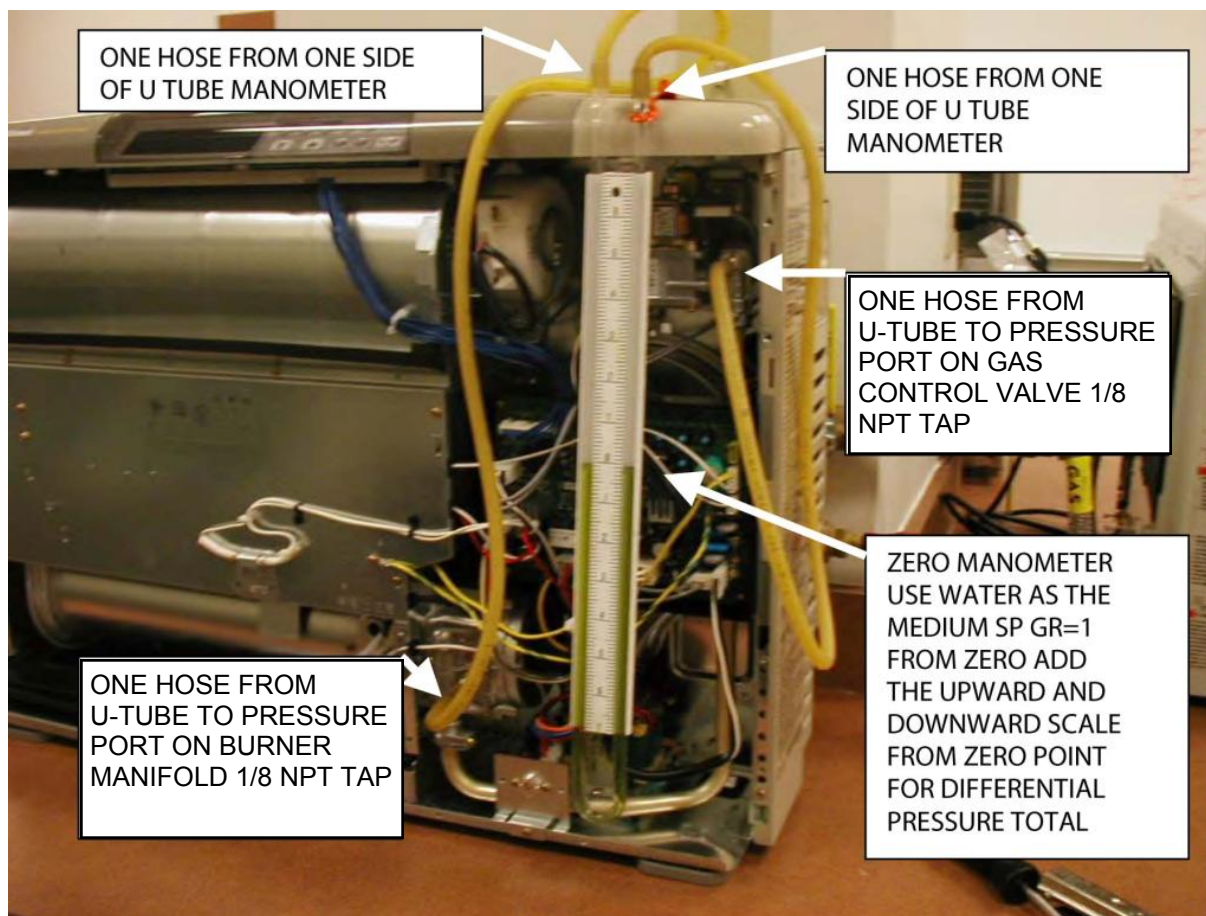

- The zero point is marked on the manometer.
- To read the differential pressure, add from zero upward and from zero downward.
- Differential pressures must be re-set if the PC board or gas control valve is replaced, or if the appliance is converted for gas type.

## Thermistor

The thermistor is a semiconductor which reacts to changes in the temperature by altering its resistance. The relationship between the temperature and the resistance is outlined in the graph. The resistance value is detected electronically, and activates the amplification circuit, which in turn operates the gas input control circuit (temperature control).

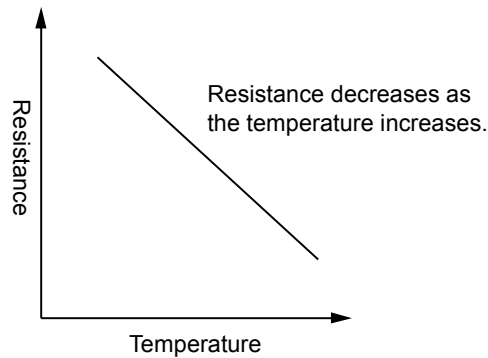

## Flame Rectification

Flame rectification is utilized to check flame presence. A flame sensing electrode consisting of a stainless steel rod supported in a ceramic insulator (flame rod) is positioned above the main burner. An alternating current is applied to the flame rod by the flame guard amplifier. The body of the burner and the flame guard amplifier (FGA) are both grounded.

The principle of flame rectification relies on the ability of the flame to conduct positively charged ions more easily than negatively charged ions. This characteristic is called flame rectification, as the current leaving the burner, having passed through the flame, is no longer an alternating current. The signal returning to the FGA has been rectified by the flame, and is used to determine flame presence.

The signal can only be produced by the flame. Short circuits, dirty contacts and other fault situations cannot simulate the rectified signal. The FGA section of the PC board sends an amplified signal to the main PC board to indicate flame presence, allowing the gas valves to remain open.

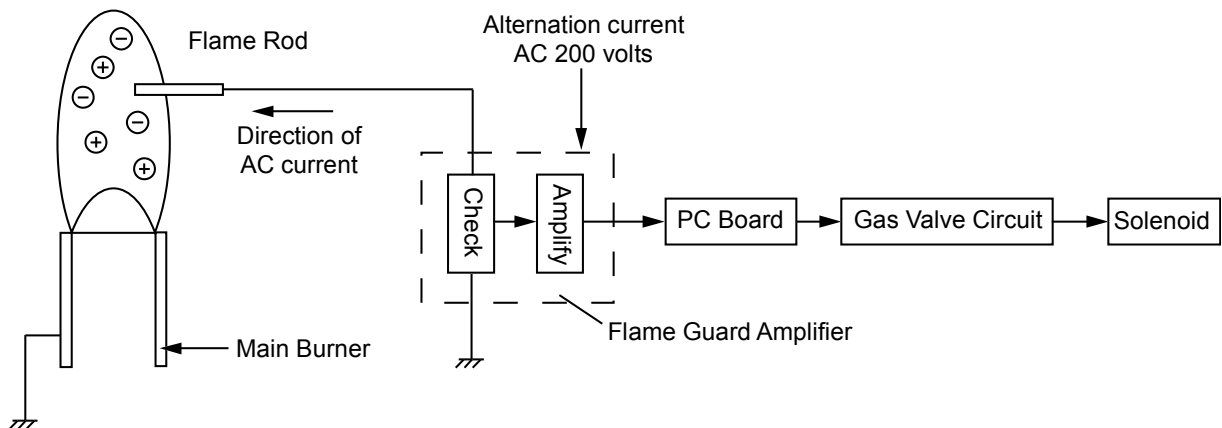



## Setting a Maximum Temperature

RHFE-263FA/FAII, RHFE431WTA, RHFE-556WTA, RHFE-1004FA

1. Plug unit up to the power supply circuit.
2. Now with the unit in the “**Off**” mode press the “**UP**” button first and then press the “**Test Switch**”. This will enter the unit into the programming mode.
3. To begin programming your desired temperature limit set point, press the “**Up**” or “**Down**” temperature adjustment button on the control panel until you have achieved your set point. Once you have select your maximum temperature set point, press the “**Test Switch**” once, this locks in your maximum operating temperature at the temperature you selected.

Temperature set point limits are - (H) high fire, 80, 78, 76, 74, 72, 70. The unit will limit its operating temperature to one of the set points above, based on your selection.

The ENERGYSAVER® models below have the ability to set a maximum temperature limit directly from the control panel. This is beneficial to landlords and property management for conserving energy and reducing unnecessary gas consumption.

Procedure for Setting Maximum Temperature Limit on ENERGYSAVER® Furnaces		
RFA Models: <b>ES08, ES11, ES17, ES22</b>	WTA Models: <b>EX17, EX22</b>	RFA and FTA Model: <b>ES38</b>
FTA Models: <b>EX08C, EX11C, EX17C, EX22C</b>		
1. While the unit is off, press the “Function Lock” or “Child Lock” and “Up” arrow buttons at the same time for about 3 seconds until the unit beeps.	1. While the unit is off, press the “Economy” and “Select” buttons at the same time for about 3 seconds until the unit beeps.	1. While the unit is off, press the “Economy” and “up” buttons at the same time for about 3 seconds until the unit beeps.
2. Select the maximum temperature with the up and down buttons.		
3. Press the On/Off button to save the new setting.		

## Harmonic Noise

RHFE-1004FA (using propane)

On occasion, a whistling noise may come from the RHFE-1004FA using propane gas. This harmonic noise can be attributed to varying gas compositions and is more prevalent on new tank sets that may still have high traces of methanol in the system. The adjustments recommended are not detrimental to the operation of the appliance in any way.

### PROCEDURE:

1. Perform the Gas Pressure Setting Procedure. During this procedure, set the low fire manifold gas pressure to 3.9” W.C. and the high fire manifold gas pressure to 9.8” W.C.
2. After performing the above procedure, set the low fire burner air shutter to three notches. This adjustment rod can be found on the right hand front burner just under the gas line where it enters the combustion chamber. Loosen the set screw in the brass slide and slide the shutter rod out to the third notch.

RHFE-201FA  
RHFE-263FA/FAII  
RHFE-1004FA/RFA/FTA

1. With the appliance unplugged (electrical power source disconnected), disconnect both air pressure hoses from the right side of the appliance. Install the new PC board. After installing the PC board, re-apply the power to the appliance.
2. Turn on the gas and power supply to the appliance. With the unit in the Off position, press the SW1 switch at the top of PC board until it beeps.
3. Select the correct code for your model, gas type, and altitude using ▲ and ▼ buttons:

**RHFE-201FA, RHFE-263FA / FAII**

- L1: Propane gas below 2000 ft (610 m)
- L2: Propane gas 2001-4500 ft (610-1372 m)
- L3: Propane gas 4501-7800 ft (1372-2377 m)
- L4: Propane gas 7801-10200 ft (2378-3109 m)
- A1: Natural gas below 2000 ft (610 m)
- A2: Natural gas 2001-4500 ft (610-1372 m)
- A3: Natural gas 4501-7800 ft (1372-2377 m)
- A4: Natural gas 7801-10200 ft (2378-3109 m)

4. Press the SW1 test button to record the gas type code into memory. The LED will display "F1". If not shown, use the ▲ and ▼ buttons to obtain "F1".
5. Press the Test button to enter this code into memory.
6. The LED will display the temperature scale. Use the ▲ and ▼ buttons to select the Fahrenheit or Celsius scale.
7. Press the Economy button for more than 2 seconds to enter the temperature scale into memory.

**The LED display turns blank and the unit returns to the normal off mode. Reinstall the air pressure hoses before turning the unit to the ON position. Program the correct low fire and high fire gas pressure settings. Do not adjust gas pressure on this appliance using the screw on top of the gas valve.**

**RHFE-1004FA/RFA/FTA**

High altitude is above 2000 ft (610 m).

- L1: Propane gas at low (sea level) altitude
- L2: Propane gas unit at high altitude
- A1: Natural gas at low (sea level) altitude
- A2: Natural gas unit at high altitude

4. Press the Economy button to record the gas type code into memory.

**The LED display turns blank and the unit returns to the normal off mode. Reinstall the air pressure hoses before turning the unit to the ON position. Program the correct low fire and high fire gas pressure settings. Do not adjust gas pressure on this appliance using the screw on top of the gas valve.**

1. Remove power and shut off gas to the appliance.
2. Disconnect both Pressure tubes from Pressure Switch (Black tube in front, Clear tube in back).
3. With the unit in the "Off" position, press the SW1 "Test" switch until it beeps.
4. Select the gas type and altitude accordingly using the "UP" and "Down" buttons:
  - L1: Propane below 2000ft.
  - L2: Propane 2001-5200ft.
  - L3: Propane 5201-7700ft.
  - L4: Propane 7701-10200ft.
  - A1: Natural Gas below 2000ft.
  - A2: Natural Gas 2001-5200ft.
  - A3: Natural Gas 5201-7700ft.
  - A4: Natural Gas 7701-10200ft.
5. Press the SW1 "Test" button to lock in the altitude/gas type. The LED will display "F1". If it does not use the "up/down" arrows to obtain "F1".
6. Press the SW1 "Test" Button to lock the code into memory.
7. The LED will now display the temperature scale "F" or "C" use the "up/down" arrows to scroll between the Fahrenheit and Celsius scale.
8. To lock in all code and remove the "OF" from the board you must press and hold the "Economy" button for two seconds.
9. The LED will go blank, if the "OF" is displayed repeat steps 3-8.
10. Reinstall both pressure tubes add gas back to unit. The unit is now ready to set the high and low fire pressures.
11. Set high and low fire pressures the unit will display a "73" instead of a "78". You have to set the "LF" (low fan) and "HF" (high fan).
  - Press the "Test" button until "LF" is displayed. Verify that the gas pressure is equivalent to your "PL" pressure. Press the "Economy" button to lock setting into memory. Your display will flash "18".
  - Press the "Test" button until "HF" is displayed. Verify that the gas pressure is equivalent to your "PH" pressure. Press the "Economy" button to lock the setting into memory. Your display will flash "78".
12. You can now power the unit down replace test port screws and check normal operating sequence.

1. Once the new PCB is installed, add power to the unit an "OF" will show on the LED display.
2. Remove power and gas to the unit.
3. Set dipswitches to correct setting, use table below:

Altitude	Gas Type	1	2	3	4	5	6	
0-2000 ft (0-610 m)	Natural Gas	OFF	OFF	OFF	OFF	ON for EX17	ON for Celsius	
	Propane	ON	ON	ON				
2001-5200 ft (611-1585 m)	Natural Gas	ON	OFF	OFF				
	Propane	OFF	ON	ON				
5201-7700 ft (1586-2347 m)	Natural Gas	OFF	ON	OFF				
	Propane	ON	OFF	ON				
7701-10200 ft (2348-3109 m)	Natural Gas	OFF	OFF	ON				
	Propane	ON	ON	OFF				
						OFF for EX22	OFF for Fahrenheit	

4. Once dip switches are set, add power and gas back to the unit.
5. Press the "Test" button and "Economy" should blink.
6. Press and hold the "Economy" button. The display should read "PF".
7. Press the "Set Times" button and the unit will fire.
8. Follow the Gas pressure setting procedure for the unit.
9. Set high and low fire pressures the unit will display a "73" instead of a "78". You have to set the "LF" (low fan) and "HF" (high fan).
  - Press the LF button "LF" will be displayed. Verify that the gas pressure is equivalent to your "PL" pressure. Press the "LF" button to lock setting into memory.
  - Press the HF button "HF" will be displayed. Verify that the gas pressure is equivalent to your "PH" pressure. Press the "Economy" button to lock the setting into memory. Your display will flash "78".
10. Power down the unit, remove manometer and replace test port screws. You can now verify normal operating sequence.

## Removal of "OF" on New PC Board Installation

RHFE-202FTA  
RHFE-265FTA  
RHFE-434FTA  
RHFE-559FTA

- Turn Power and Gas off and replace PCB. The Pressure Sensor (Part #1004F-2051), Sensor Lead Assembly (Part #1004F-2053) and Igniter (Part #205000037) will need to be transferred from the original PCB.
- Turn on power to the unit, there will be an "OF" in the units display.
  - With the unit in the "Off" position press and hold the Test Switch at the top of the PC board until it beeps.
  - The unit will display a "0"; press the Test Switch once more. To display the Altitude/Gas Type. \*Note: You will be unable to adjust those parameters.

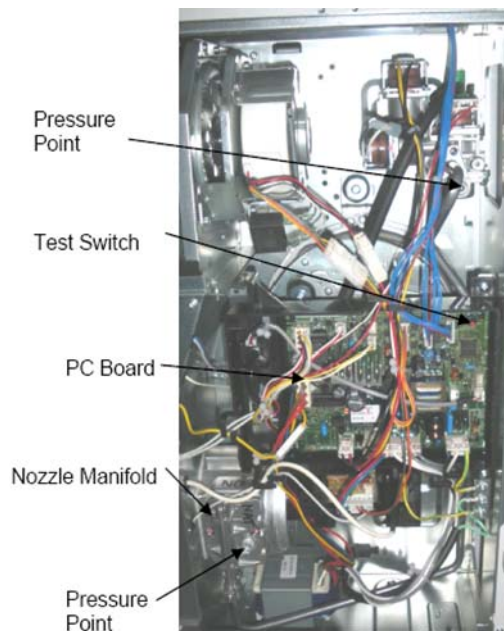

	Natural Gas				Propane Gas			
Code	A1 / A5	A2 / A6	A3 / A7	A4 / A8	L1 / L5	L2 / L6	L3 / L7	L4 / L8
Altitude	0-2000 ft 0-610 m	2001-5200 ft 611-1585 m	5201-7700 ft 1586-2347 m	7701-10200 ft 2348-3109 m	0-2000 ft 0-610 m	2001-5200 ft 611-1585 m	5201-7700 ft 1586-2347 m	7701-10200 ft 2348-3109 m

- With the Altitude/Gas Type in the display press and hold the "Set Back" button. The "Economy" Button will flash. While still holding "Set Back" Press and hold "Economy". The unit will beep and "- : -" will be in the units display.
- With the unit in the Off position you can now press and hold the Test Switch until it beeps. You will be able to adjust your Altitude/Gas Type now using the ▲ and ▼ buttons.
- Turn on gas to the unit and start the Gas Pressure Setting procedure. \*\*\*Note before completing step #12 in the Gas Pressure Settings, you must set your High and Low fan settings.
  - After setting the "PH" (High Fire), press the Test Switch until the number "7" is displayed. That is your High Fan speed. Verify that the pressures on your manometer match your "PH" (High Fire) settings. Using the ▲ and ▼ buttons reduce the number "7" to number "1". This is your Low fan speed. Verify that the pressures on your manometer match your "PL" (Low Fire) settings.
  - You can now proceed to step #12.

## Wire Diagram Abbreviations

---

MARK	PART NAME
MS	MAIN SWITCH
R.TH	THERMISTOR
TF	THERMAL FUSE
F	FUSE
ER	ELECTRODE
POV	MODULATING SOLENOID VALVE
TR	TRANSFORMER
FR	FLAME ROD
CF	CONVECTION FAN
OH. TH	OVER HEAT THERMISTOR
OHS	OVER HEAT SWITCH
FM	CONVECTION FAN MOTOR
SP	SPARKER
SV	SOLENOID VALVE
BL	COMUSTION FAN MOTOR
FCC	FAN CONTROL CIRCUIT
CPU	CENTRAL PROCESSING UNIT
MB	MAIN BURNER
PS	PRESSURE SENSOR
RCR	REMOTE CONTROL RECEIVER
TB	TERMINAL BLOCK

CODE	COLOR
bk	black
bl	blue
br	brown
gr	green
pl	purple
r	red
w	white
y	yellow
gy	gray
or	orange

## Serial Number Format

---

### Water Heaters and Direct Vent Furnaces

On direct vent furnaces manufactured **before June 1, 2010**, the Rinnai serial number will consist of four numbers, followed by a dash, followed by six numbers. The first four numbers are separated by a period (.). The first two numbers indicate the year and the next two numbers indicate the month.

Example: 03.06-001000 This unit was manufactured in 2003 (03) and the sixth month (June) – (06).

On direct vent furnaces manufactured **on or after June 1, 2010** the Rinnai serial number will consist of four letters, followed by a dash, followed by six numbers. The first letter indicates the year of manufacture and the second letter indicates the month of manufacture according to the table below.

Example: BH.AB-000123 This product was manufactured in August, 2010.

The third and fourth letters indicate manufacturing location and product type. The 6 digit number will be sequential and reset every year.

### Year/Month Table

For applicable models and manufacturing dates: the first letter indicates the year of manufacture  
the second letter indicates the month of manufacture.

<u>Year</u>		<u>Year</u>		<u>Month</u>	
2009	A	2021	N	January	A
2010	B	2022	P	February	B
2011	C	2023	R	March	C
2012	D	2024	S	April	D
2013	E	2025	T	May	E
2014	F	2026	W	June	F
2015	G	2027	X	July	G
2016	H	2028	Y	August	H
2017	J	2029	Z	September	J
2018	K			October	K
2019	L			November	L
2020	M			December	M

# — Ask about — Rinnai®

Rinnai's other fine products

EXPERIENCE OUR INNOVATION™

---



### Tankless Water Heaters

- Residential and Commercial Applications
  - Continuous Hot Water
  - ENERGY STAR® qualified models
  - Up to 9.8 GPM
  - Internal or External Installation
  - Digital Temperature Control
- 



### Condensing Tankless Water Heaters

- Residential and Commercial Applications
  - ENERGY STAR® qualified models
  - Up to 0.96 Energy Factor (EF)
  - Internal or External Installation
  - Pair up with the Rinnai Air Handler for efficient home heating
- 



### Direct Vent Furnaces

- High Efficiency
  - Cool-to-the-touch Cabinet
  - Vent Terminal A Included
  - Blower Included
- 



### Hydronic Furnace

- Designed for Use with Rinnai Systems
  - Domestic Hot Water Priority
  - Optional Programmable Thermostat
  - Zero Clearance to Combustibles
  - Accommodates Standard Cased-Coils
- 



### Boilers

- Residential and Commercial Applications
  - ENERGY STAR® qualified models
  - Up to 96.5% AFUE efficiency
  - Compact wall mounted design
  - ASME accredited models
- 

Register your product at  
[www.rinnai.us](http://www.rinnai.us)  
or call 1-866-RINNAI1 (746-6241)

For information on Rinnai's products contact  
Rinnai America Corporation  
103 International Drive  
Peachtree City, GA 30269  
TOLL FREE: 1-800-621-9419  
FAX: 678-829-1666  
[www.rinnai.us](http://www.rinnai.us)

200000014 Rev A