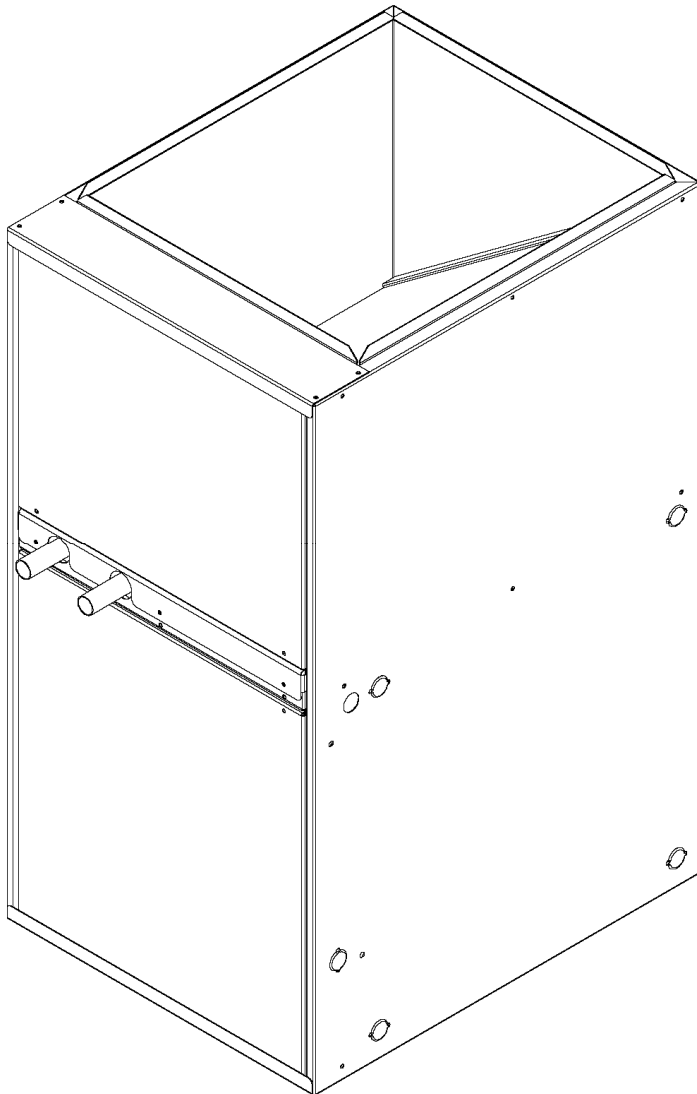


# Installation, Operation, and Maintenance Manual



Consumer Safety Information .....	2
Overview of the Rinnai Hydronic Furnace .....	3
Model Number Nomenclature .....	3
Physical Data .....	4
Receiving & Checking Equipment .....	5
Installation	
Clearances .....	5
Locating and Mounting .....	6-9
Plumbing .....	10-13
Electrical Connections .....	14-16
Dip Switch Options.....	17
Thermostat Installation.....	17-18
Start-Up Procedure .....	19
Troubleshooting .....	20-23
Sequence of Operation .....	24-26
Maintenance.....	26, 27
Selection Guide.....	27, 28
Specifications .....	29
Air Delivery Performance .....	30
Accessories.....	31
Hydronic Furnace Output.....	32-34
Wiring Diagrams .....	35-37
Parts List .....	38-39
Limited Warranty .....	40-41

To register your hydronic furnace or tankless water heater, please visit [www.rinnairregistration.com](http://www.rinnairregistration.com).



### Quality Assurance



This product is manufactured in a facility registered by UL to ISO 9001.

# Consumer Safety Information

## SAFETY DEFINITIONS



Indicates safety alerts. When this symbol is seen on the Hydronic Furnace and in all instructions and/or manuals, be alert to the potential for personal injury. Recognize signal words DANGER, WARNING, and CAUTION. These words are used with the safety alert symbol.

### **DANGER**

Indicates an imminently hazardous situation which, if not avoided, will result in death or serious injury.

### **WARNING**

Indicates a potentially hazardous situation which, if not avoided, could result in death or serious injury.

### **CAUTION**

Indicates a potentially hazardous situation which, if not avoided, could result in minor or moderate injury. It may also be used to alert against unsafe practices.

### **NOTICE**

This is used to highlight important information which will aid in installation, improve reliability or enhance operation.

## SAFETY CONSIDERATIONS

Before any work is undertaken, it is imperative to observe all precautions as stated in this manual, on tags, and/or labels, together with any other safety measures that may apply.

- Wear safety glasses and work gloves.
- When practical, objects to be brazed shall be moved to a designated safe location or, if the objects to be brazed cannot be readily moved, all movable fire hazards in the vicinity shall be taken to a safe place, or otherwise protected.
- Use quenching cloth for all brazing and un-brazing operations.
- Suitable fire extinguishing equipment shall be immediately available in the work area and shall be maintained in a state of readiness for instant use.

Read these installation instructions carefully and adhere to all WARNINGS and CAUTIONS. Consult local building codes, Occupational Safety & Health Administration (OSHA) and National Electrical Code (NEC) for special requirements.

Improper installation, modification, service, maintenance, or use of Hydronic systems can cause electrical shock, burns or other conditions which may cause personal injury or property damage. Consult a qualified installer, service agency, or your distributor for information or support. The qualified installer or agent must use factory authorized kits and/or accessories when installing this product. Refer to the appropriate Rinnai® literature for listing.

### **WARNING**

Before installing or servicing the Hydronic Furnace, always turn off all power to unit. There may be more than 1 disconnect switch. Electrical shock can cause personal injury or death.

### **CAUTION**

Failure to follow this caution may result in personal injury. Sheet metal parts may have sharp edges or burrs. Use care and wear appropriate protective clothing.

### **NOTICE**

Application of this Hydronic Furnace should be indoors. Special attention should be given to unit sizing and piping, filling, and purging.

Read the entire instruction manual before starting the installation.

# Overview of the Rinnai Hydronic Furnace

## INTRODUCTION:

The optimum in hydronic technology: the newly designed Rinnai® multi-position Hydronic Furnaces offer a unique solution for a wide variety of small and medium sized residential and light commercial applications. They are compact and ready to fit in tight spaces which may include, but not limited to, attics, basements, closets, crawlspaces, and utility rooms.

The 37AHA units are equipped with an intelligent microprocessor control that allows for domestic hot water priority and adapts to available hot water flow for space heating by automatically regulating the pump and blower sequence to maximize comfort.

These unique Hydronic Furnaces are designed to work in combination with our line of Rinnai® tankless products to deliver a wide variety of heating capacities that cover the entire residential and light commercial heating spectrum.

Because our units are designed specifically to the Rinnai® tankless products, our stated capacities are fine tuned and are based on the "Hydronic Furnace / tankless water heater" match set and **NOT** a given water flow rate.

## CODES AND STANDARDS:

It is the responsibility of the installer to follow all national codes, standards and local ordinances, in addition to instructions laid out in this manual. The installation must comply with regulations of the local building, heating, plumbing, and other codes. Where local codes are not applicable, the installation must comply with the national codes and any and all authorities having jurisdiction.

The following is a suggested list of codes and standards for the United States and Canada:

### General Installation

Installation of Air Conditioning and Ventilating Systems  
NFPA 91 (latest edition)

### Duct Systems

Sheet Metal and Air Conditioning Contractors National Association (SMACNA)

American Society of Heating, Refrigeration, and Air Conditioning Engineers (ASHRAE)

2001 Fundamentals Handbook Chapter 34 or 2000 HVAC Systems and Equipment Handbook Chapters 9 and 16

US and CANADA: Air Conditioning Contractors Association (ACCA) Manual D

### Acoustical Lining and Fibrous Glass Duct

US and CANADA: current edition of SMACNA; NFPA 90B as tested by UL Standard 181 for Class I Rigid Air Ducts

### Electrical Connections

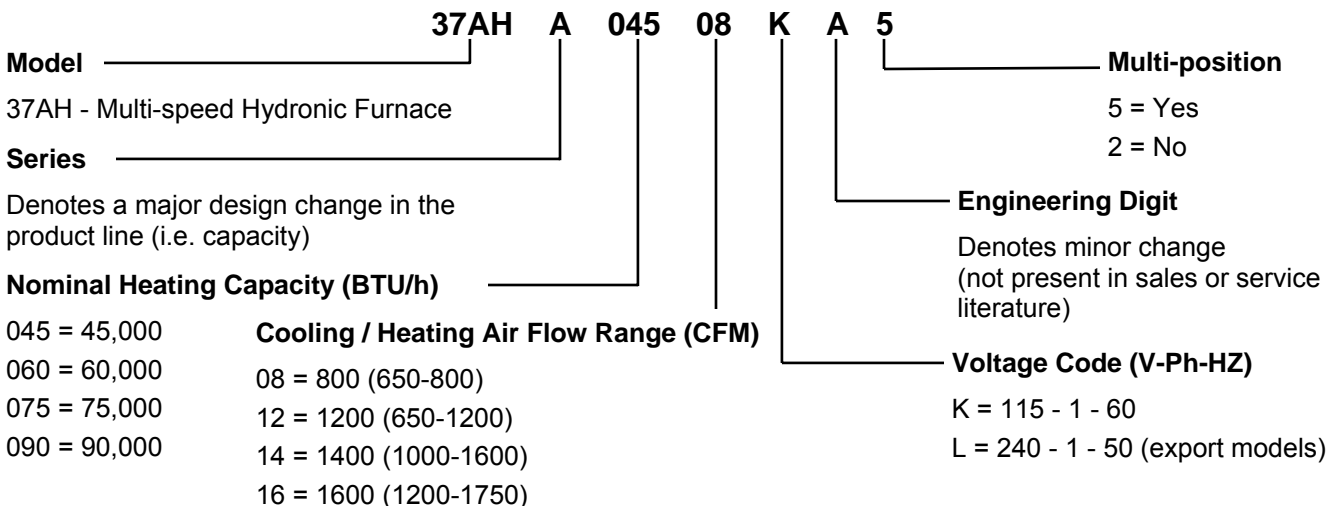
US: National Electrical Code (NEC) ANSI/NFPA 70 (latest edition)

CANADA: Canadian Electrical Code CSA C22.1 (latest edition)

### Plumbing Systems:

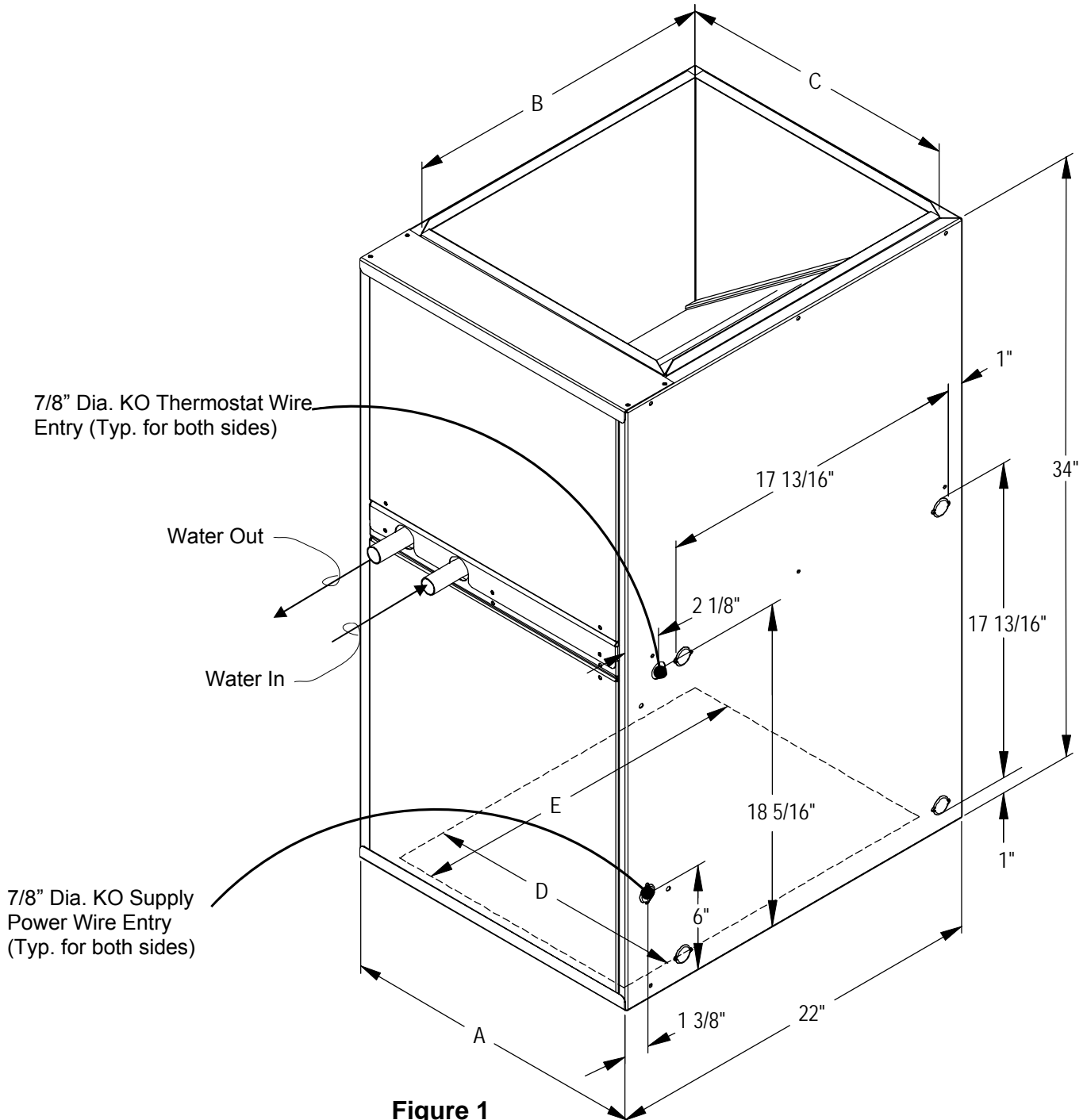
US and CANADA: ICC International Plumbing Code (IPC); Uniform Mechanical Code (UMC); Uniform Plumbing Code (UPC)

## Model Number Nomenclature



**Table 1 - Physical Data**

UNIT SIZE	DIMENSIONS									
	A		B		C		D		E	
	in.	mm	in.	mm	in.	mm	in.	mm	in.	mm
37AHA04508KA5	14	355.6	18	457.2	12	304.8	10 - 1/2	266.7	19	482.6
37AHA06012KA5	17 - 1/2	444.5	18	457.2	16	406.4	16 - 11/16	423.9	19 - 1/4	489.0
37AHA07514KA5	21	533.4	18	457.2	20	508	18 - 11/16	474.7	19 - 1/2	495.3
37AHA09016KA5	24 - 1/2	622.3	18	457.2	24	609.6	21 - 1/8	536.6	19	482.6



**Figure 1**

# Receiving and Checking Equipment

## IDENTIFY UNIT

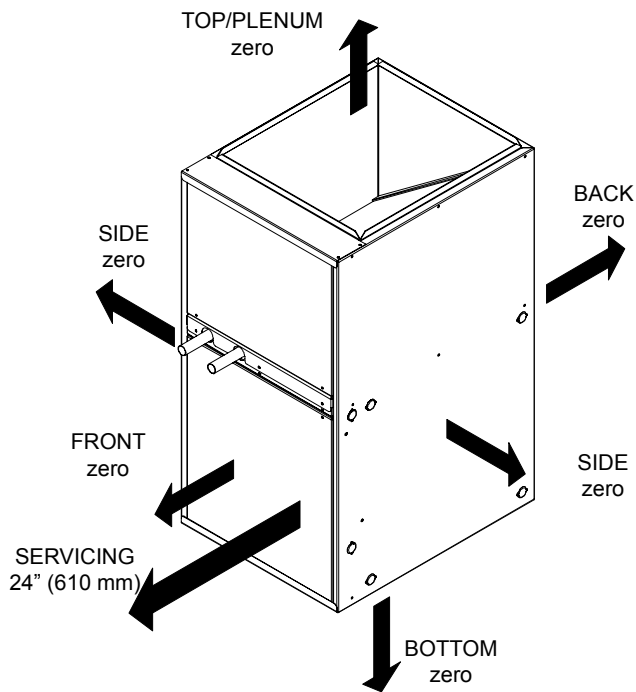
The unit model number and serial number are stamped on the unit identification / name plate (located on the top right side of unit). Check this information against shipping papers and job requirements.

## INSPECT SHIPMENT

Upon receipt of a 37 Series Hydronic Furnace the packaging should be checked for peripheral signs of transportation damage while unit is still in the shipping package. If unit appears to be damaged or is torn loose from its anchorage, the unit shall be immediately examined by the receiving party before removal. If

damage is found, the receiving party must sign the driver's delivery receipt noting all damage (i.e. carton damage and/or product damage) as well as contact the last carrier immediately, preferably in writing, requesting inspection by the carrier's agent. All claim papers **MUST** be forwarded to Rinnai® America Corporation for processing. In general, upon receipt of product, be sure to check all items against shipping list; if items are found to be missing, it should be noted as such on the driver's delivery receipt; and the receiving party shall also immediately notify the area distributor. To prevent loss or damage, leave all parts in original packages until installation.

# Installation



**Figure 2:** Minimum Clearance to Combustible Construction

The 37AHA Series Hydronic Furnace needs to be installed and commissioned by a knowledgeable qualified professional.

### NOTES:

1. This Furnace is approved for upflow, downflow, and horizontal configurations.
2. Clearance arrows do not change with Hydronic Furnace orientation.
3. **This Hydronic Furnace is for indoor installation only.**
4. Unit(s) shall be installed in such a way as to ensure that the electrical components are protected from any contact with water.
5. Unit(s) shall not be installed directly on any combustible material other than wood flooring.
6. This unit is designed to be used with an air distribution system (ductwork). Refer to the Air Distribution Ductwork section.
7. The installer shall provide ample space for servicing and cleaning. Always comply with minimum fire protection clearances shown in Figure 2.
8. The 37AHA units are designed to be installed vertically or horizontally on the floor; units may also be hung from the ceiling or wall. Be sure to allow appropriate clearances for wiring, piping, and servicing.

## **WARNING**

Do not install this unit if the unit is damaged.

Do not install this unit if any part or all of unit has been under water. Refer to the Receiving and Checking Equipment section.

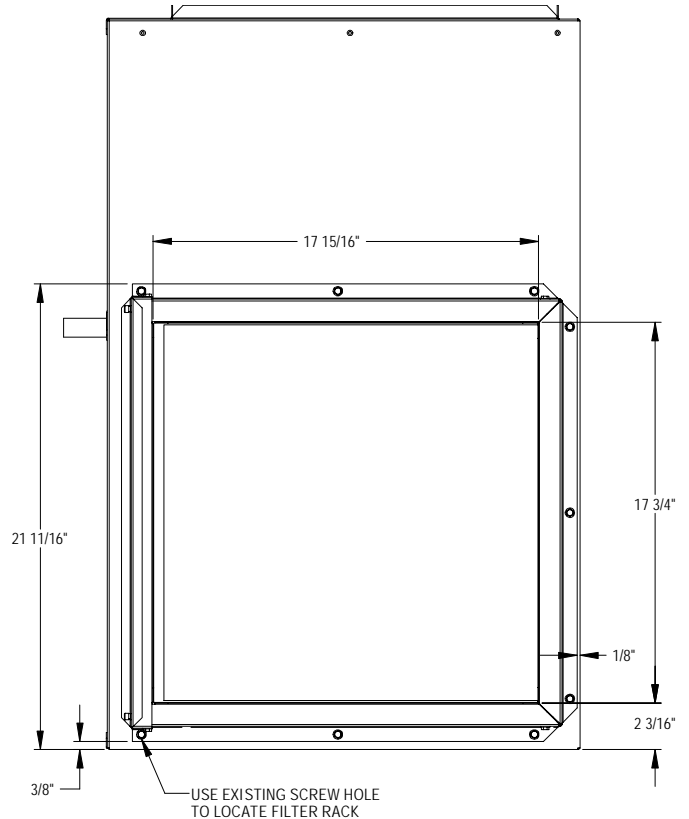
# Installation

## LOCATING AND MOUNTING THE HYDRONIC FURNACE

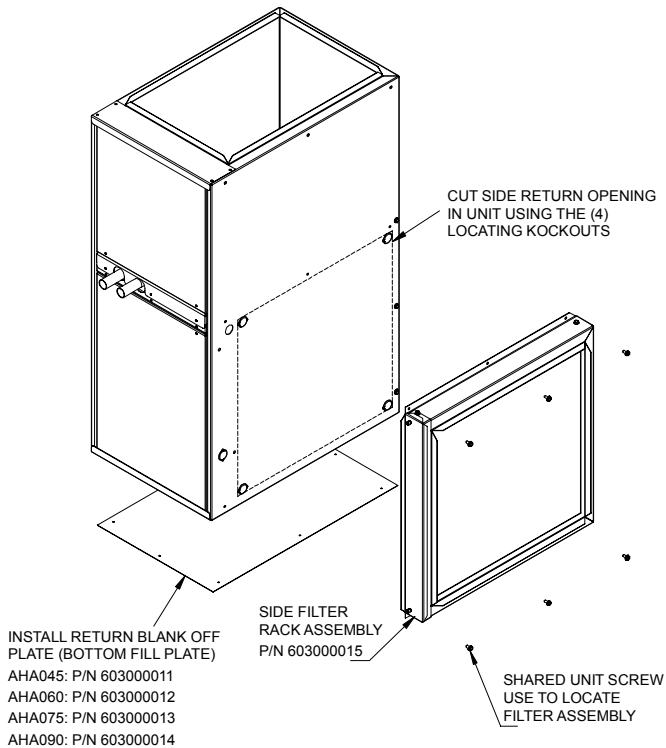
### General

The multi-position 37AHA Series Hydronic Furnaces are shipped in packaged configuration. This means that the units may be installed without assembly and/or modifications when configured for bottom return air inlet application; however, some modifications and assembly are necessary if units are to be installed in an application that requires side return air inlet arrangement. For instructions on required modifications and assembly refer to Figures 3 and 4.

**NOTE:** For side return application, obtain Side Filter Rack and "Bottom Fill Plate" from your area authorized Rinnai® distributor.

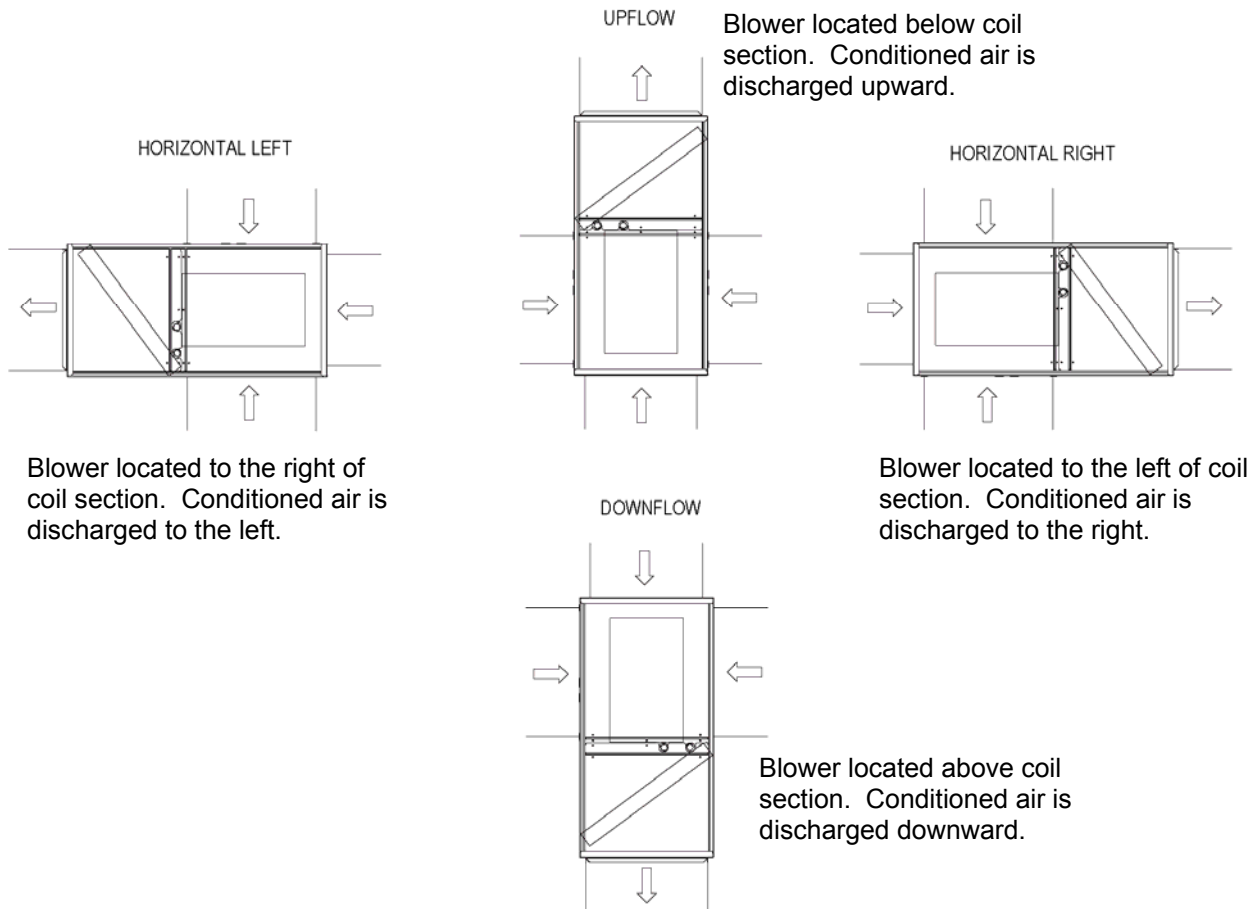


**Figure 4:** Side Filter Rack Installation



**Figure 3:** Modification of Unit to Accommodate Side Filter Rack Installation

# Installation



**Figure 5:** Multi-Position Orientation

## Upflow Installations

The 37AHA Hydronic Furnace is ready to install in the up-flow position without modifications.

The unit **MUST** be supported on the bottom **ONLY** and set on a field supplied supporting frame or plenum. Supporting frame or plenum must be anchored to the unit and to the floor or wall.

The 37AHA Furnaces are shipped without a bottom fill plate. If side return installation is desired, the return opening (Bottom) must be blanked off. If a bottom fill plate is required, install only a factory authorized bottom fill plate. Refer to the Rinnai Accessory list for details. For side filter rack installation instructions refer to Figures 3 and 4.

## Downflow Installation

The 37AHA Hydronic Furnace is ready to install in the down-flow position without assembly or modifications when configured for bottom return air inlet installation. If side return air inlet installation is desired refer to Figures 3 and 4.

## Horizontal Left and Right Installations

Without Cased Coil:

If a cased coil is **NOT** being installed, the cabinet can be placed on either side for horizontal airflow as shipped, when configured for bottom return air inlet installation. If side return air inlet installation is desired refer to Figures 3 and 4.

With Cased Coil (Field Supplied):

Refer to the manufacturer's Cased Coil installation instructions for details.

# Installation

## CLOSET INSTALLATION (RETURN AIR THRU OPENING OR GRILL)

The 37AHA Hydronic Furnace can be installed in a closet on a supporting stand or be mounted from the closet wall using the closet as the return air plenum. Unit should be high enough from the floor to provide unimpeded return air flow into the bottom of the cabinet.

Closet return air opening can be on the front (in closet door), side (thru the wall) or a combination of both, providing there is clearance on the sides between unit's cabinet and closet. Refer to ACCA Manual D or SMACNA for sizing and free area recommendations.

**NOTE:** Local codes may limit application of systems without a ducted return to single story dwellings.

## SUSPENDED CABINET INSTALLATION

If the cabinet cannot be supported on a frame or supported from the wall, it may be suspended.

Use metal strapping or threaded rod with angle iron supports under cabinet for support. These supports **MUST** run parallel with the length of the cabinet (see Figures 6 and 7).

Ensure that there is adequate room to remove service and access panels after installing supporting brackets.

If an auxiliary drain pan is required, the support is to be placed under a drain pan. In such installations the unit will need to be supported on vibration isolators (rubber or Styrofoam blocks).

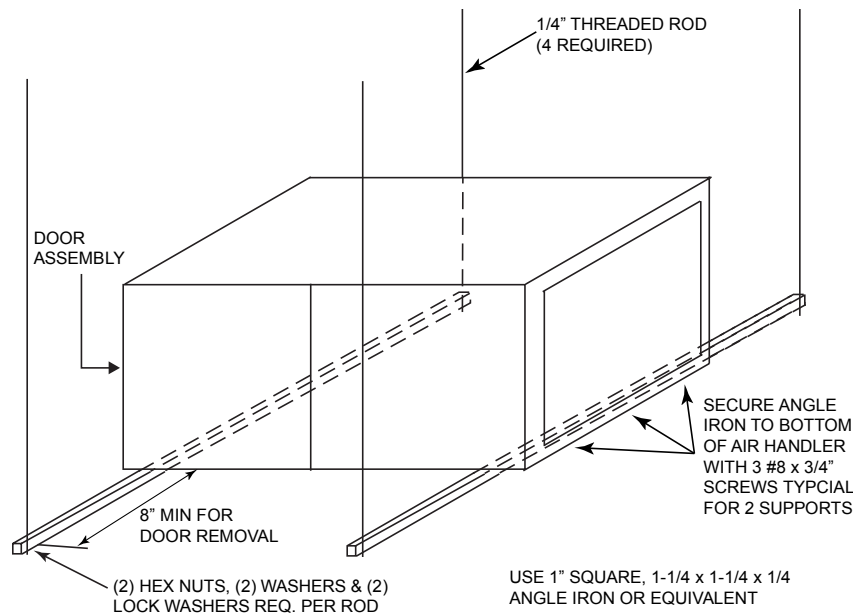
**IMPORTANT:** When a 37AHA unit is matched with an evaporative type (cased coil/condensing unit) split system for cooling application and the system is installed above a finished ceiling and/or an occupied space, building codes may call for a secondary insulated condensate pan (by others) to be installed under the entire unit. In other instances, some local codes may allow the running of a separate, secondary condensate line in lieu of the required drain pan. It is the responsibility of the installer to consult local codes for compliance.

## WARNING

It is the installer's responsibility to use an appropriate hanging method capable of supporting the unit's weight. Refer to the specification section of this document for the respective unit's installed weights.

## NOTICE

For seismic hanging requirements, refer to local codes.



**Figure 6:** Horizontal Unit Suspension



# Installation

## Attachment Methods Using Straps

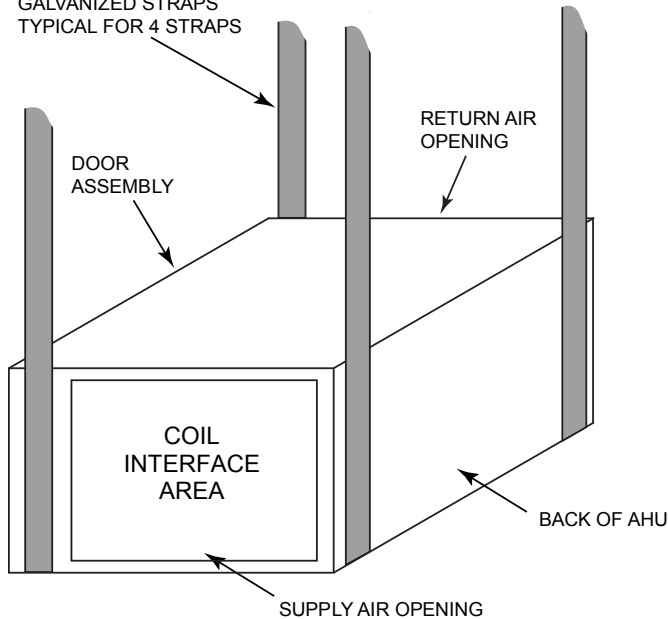
### Method 1

Use (4) #8 x 3/4 sheet metal screws for each strap. The straps should be vertical against the furnace sides and not pull away from the furnace sides.

### Method 2

Fold all straps under the furnace and secure with (4) #8 x 3/4 sheet metal screws (2 screws at the side and 2 screws at the bottom. (Care must be taken not to drive the screw through the coil.)

1 INCH x 22 GAUGE  
GALVANIZED STRAPS  
TYPICAL FOR 4 STRAPS



**Figure 7:** Horizontal Unit Suspension with Straps

## DUCT CONNECTIONS

### Supply Duct

The supply ductwork must be attached to the outside of the flange on the air discharge end of unit. Flexible connectors may be used if desired.

### Return Duct

The return ductwork should be attached to the air return side (bottom or side) of unit using sheet metal screws or other fasteners.

For side return air inlet installation see the Figures 3 and 4.

## FILTER INSTALLATION

Internal filter rack and a 1 inch disposable filter are standard on all models. Refer to the Specifications section for dimensions.

## AIR DISTRIBUTION SYSTEM

### Existing Ductwork

It is the responsibility of the installer to inspect all previously installed air distribution system to determine its suitability for the new heating and/or cooling system. Existing ductwork may have to be modified and/or insulated to provide satisfactory air distribution.

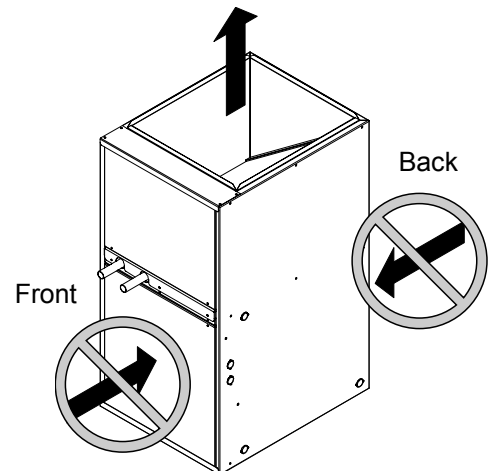
### Ductwork Installation

Connect the supply-air duct over the outside of 3/4-in. flange on the unit's discharge side. Secure the duct to the flange with proper fasteners for the type of duct used. Support the duct independently.

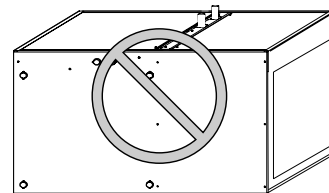
Use flexible connectors (if desired between the ductwork and the unit to prevent transmission of vibration.

Use insulation with vapor barrier for ductwork passing through unconditioned spaces.

## PROHIBITED INSTALLATIONS



**Figure 8:** The air inlet is not allowed to be at the front or back of the furnace



**Figure 9:** Do not position the furnace on its back or with it face down.

### NOTE:

Multiple Furnaces configured for installation with a single Rinnai Tankless Water Heater is prohibited.

# Installation

## PLUMBING

### Codes:

Observe all local sanitary codes when installing water lines. The water supply mating connection to the 37AHA Hydronic Air-Handling Units are made via the two (3/4 in. Dia. X 2-1/2 in. Long) copper stubs to the front-left of the unit labeled "WATER IN" and "WATER OUT" (see Figure 1). Mating connectors to be two field supplied 3/4 in. FNPT-sweat ends or two field-supplied 3/4 in. SharkBite type FNPT-push fitting ends or equivalent.

All associated hydronic piping MUST comply with ICC, UPC and any other local codes or ordinances having jurisdiction. USE POTABLE GRADE COPPER PIPING AND BRASS APPURTENANCES ONLY.

**NOTE:** Recommended piping, fittings, valves and other appurtenances (exclusive of those indicted as accessories that are available through Rinnai distribution) called for in piping schematics to be field-supplied.

### Flow Sensor Installation:

(Required for Open Loop Systems)

Care must be taken to ensure that the flow sensor is not damaged due to excessive tightening. The torque must not exceed the maximum limit stated below. The installation should be checked to ensure that no leaking is evident.

Mating connectors to be (2) 3/4" FNPT fittings (field supplied).

Pipe-work/connector alignment is imperative (avoid bending stress).

Polytetrafluoroethylene (PTFE) thread seal tape (teflon tape), or equivalent, is recommended.

Tighten fittings to maximum torque of 15lb/ft (20Nm).

### Soldering Copper Tubing:

The common method of joining copper tubing in hydronic heating systems is soft soldering. Plumbing codes do not allow solders containing lead to be used for domestic water service. USE ONLY 95/5 tin/antimony solder for all piping systems that incorporate a domestic water supply.

Note: Precautions must be taken during soldering to avoid debris or solder from lodging in piping system.

### Mechanical Joining of Tubing:

Where used, refer to respective mechanical system manufacturer's installation instructions.

### Tubing Insulation:

Any tube conveying fluid at a temperature greater than that of the surrounding air releases heat.

Insulate all accessible hot water lines and associated valves with material, such as expanded neoprene or polyurethane 3/8-in. to 1/2-in. thick.

Match the pipe sleeve's inside diameter to the pipe's outside diameter for a snug fit. Place the pipe sleeve so the seam will be face down on the pipe. Tape, wire, or clamp insulation every foot or two to secure it to the pipe. If taping is desired, use acrylic tape instead of duct tape.

### Copper Tubing Support:

Copper tubing must be properly supported to prevent sagging or buckling. On horizontal runs with hard temper tubing, the following maximum support spacing is suggested:

- 1/2 in. to 3/4 in. tube: 5 feet maximum spacing
- 1 in. to 1-1/4 in. tube: 6 feet maximum spacing
- 1-1/2 in. to 2 in. tube: 8 feet maximum spacing

The above suggested spacing does not account for extra weight of piping components such as an expansion tank, etc. When such components are present the piping should be supported immediately adjacent to the component.

On vertical runs, copper tubing should be supported at each floor level or at a maximum of every 10 feet.

### Thermal Expansion of Piping:

In all hydronic systems, piping undergoes temperature swings as the system operates. This causes changes in the length of the piping due to thermal expansion.

If the piping is rigidly mounted, this expansion can cause annoying popping or squeaking sounds and in extreme cases, the piping can even buckle.

To counter expansion movement, design piping circuits with sufficient elbows, tees or expansion loops (only used in large systems) or piping supports that allow the tubing to expand and contract freely.

Another alternative is to install an expansion compensator fitting capable of absorbing the movement.

# Installation

## Hydraulic Resistance of Fittings, Valves, and Other Devices:

Before the total hydraulic resistance of a piping circuit can be found, the individual hydraulic resistances of all fittings, valves, or other such components must be determined. One approach is to consider each fitting, valve, or other device as an equivalent length of copper tube of the same pipe size (see Table 2).

By using the equivalent length of piping for all components in the circuit, the circuit can be treated as if it were a single piece of pipe having a length equal to the sum of the actual pipe length, the total equivalent lengths of all fittings, valves, or other devices. Refer to Figure 10 and the calculation of equivalent lengths.

## Pipe Sizing Considerations:

When selecting a pipe size for a given flow rate, the resulting average flow velocity should be between 2 and 4 feet per second.

At water flow velocities of approximately 2 feet per second, flowing water will carry air bubbles along a vertical pipe. Average flow velocities of 2 feet per second or higher can draw along air bubbles in a downward flow. At the above stated velocities air bubbles shall be routed to an air separator where they can be collected and discharged from the system. Use Taco 4900 series air separator, Model 49-075, or equivalent (field supplied).

Average flow velocities higher than 4 feet per second could cause flow noise and should be avoided.

## Expansion Tanks:

All liquids used in hydronic heating systems expand when heated. For all practical purposes, liquids are incompressible. Any container completely filled with a liquid and sealed from the atmosphere will experience a rapid increase in pressure as the liquid is heated.

To prevent this from occurring, all closed loop hydronic systems MUST be equipped with an expansion tank. Refer to expansion tank manufacture's instructions for proper sizing and installation.

# Installation

## PROCEDURE FOR CALCULATING THE TOTAL EQUIVALENT LENGTH OF PIPE

Given piping assembly as shown in Figure 10 below, what is the total equivalent length of the system?

First determine the total straight pipe lengths; next refer to table 2 to determine the equivalent straight pipe length for each fitting shown. Add together the equivalent lengths of piping and fittings.

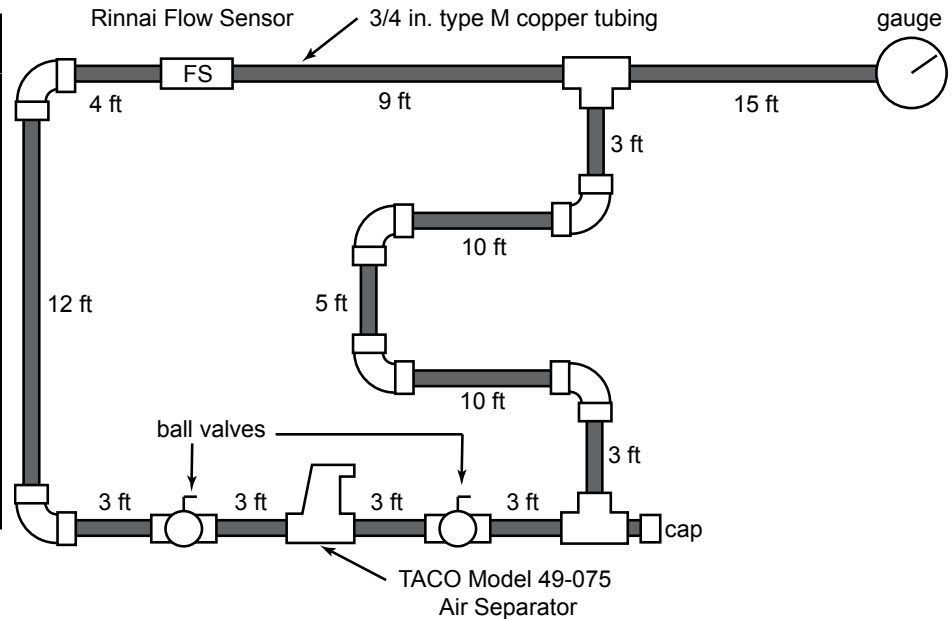
- 3/4" Tubing (total straight pipe length)....68 ft.
- (6) 3/4" 90 deg. Elbows.....6(2) = 12 ft.
- (2) 3/4" Side port tee.....2(3) = 6.0 ft.
- (1) 3/4" Taco air separator....1(0.3) = 0.3 ft.
- (1) 3/4" Rinnai flow sensor.....1(3.2) = 3.2 ft.
- (2) 3/4" Ball valves.....2(2.2) = 4.4 ft.
- Total Equivalent length.....93.9 ft.**

NOTICE

Where possible the length of pipe should not exceed 150 feet total equivalent length.

Any piping running through unconditioned space **MUST** be insulated to prevent heat loss, and possible freezing of the line.

Stickers indicating direction of flow, (WATER IN, and WATER OUT) are labeled on the outside of the cabinet. **DO NOT** reverse these lines, as this will cause the unit to malfunction.



**Figure 10** Equivalent Length Calculation

Table 2: Equivalent Length of Straight Pipe for Valves and Fittings (ft)									
Fitting or Valve	3/8"	1/2"	3/4"	1"	1 1/4"	1 1/2"	2"	2 1/2"	3"
90 deg. Elbow	0.5	1	2	2.5	3	4	5.5	7	9
45 deg. elbow	0.35	0.5	0.75	1	1.2	1.5	2	2.5	3.5
Straight thru tee	0.2	0.3	0.4	0.45	0.6	0.8	1	0.5	1
Side port tee	2.5	2	3	4.5	5.5	7	9	12	15
Reducer coupling	0.2	0.4	0.5	0.6	0.8	1	1.3	1	1.5
Gate valve	0.35	0.2	0.25	0.3	0.4	0.5	0.7	1	1.5
Globe valve	8.5	15	20	25	36	46	56	104	130
Angle valve	1.8	3.1	4.7	5.3	7.8	9.4	12.5	23	29
Ball valve	1.8	1.9	2.2	4.3	7	6.6	14	0.5	1
Swing check valve	0.95	2	3	4.5	5.5	6.5	9	11	13
Flow check valve	NA	NA	83	54	74	57	177	85	98
Butterfly valve	NA	1.1	2	2.7	2	2.7	4.5	10	15.5
Rinnai Flow Sensor	NA	NA	3.2	NA	NA	NA	NA	NA	NA
Taco 49-075 Air Separator	NA	NA	0.3	NA	NA	NA	NA	NA	NA

# Installation

## Piping Configuration

When employing a Tankless Water Heater in a hydronic system, the system is considered an Open Loop System when configured to simultaneously deliver both domestic hot water and space heating. By definition, if the circuit is sealed off from the atmosphere at all locations (as is true for most modern hydronic systems) it is called a **closed loop system**. If the circuit is open to the atmosphere at *any point*, it is called an **open loop system**. Current Rinnai tankless products are not certified for closed loop applications.

## Open Loop System

If piping is done in accordance with the recommended schematic diagram shown in Figure 11, the following purge and priming procedure applies.

### PURGING AND PRIMING THE SYSTEM:

The following procedure describes how the Rinnai® system may be piped to eliminate the need for a “purge cart” to fill the system and remove entrapped air bubbles.

**STEP 1:** CLOSE the air separator venting valve.

**STEP 2:** CLOSE ball valve 3 (BV<sub>3</sub>);

**STEP 3:** OPEN drain valve 3 (DV<sub>3</sub>) to which a hose MUST be connected and draining to a sink, drain or outdoors.

**STEP 4:** CLOSE drain valves 1 & 2 (DV<sub>1</sub> and DV<sub>2</sub>) and OPEN ball valve 2 (BV<sub>2</sub>).

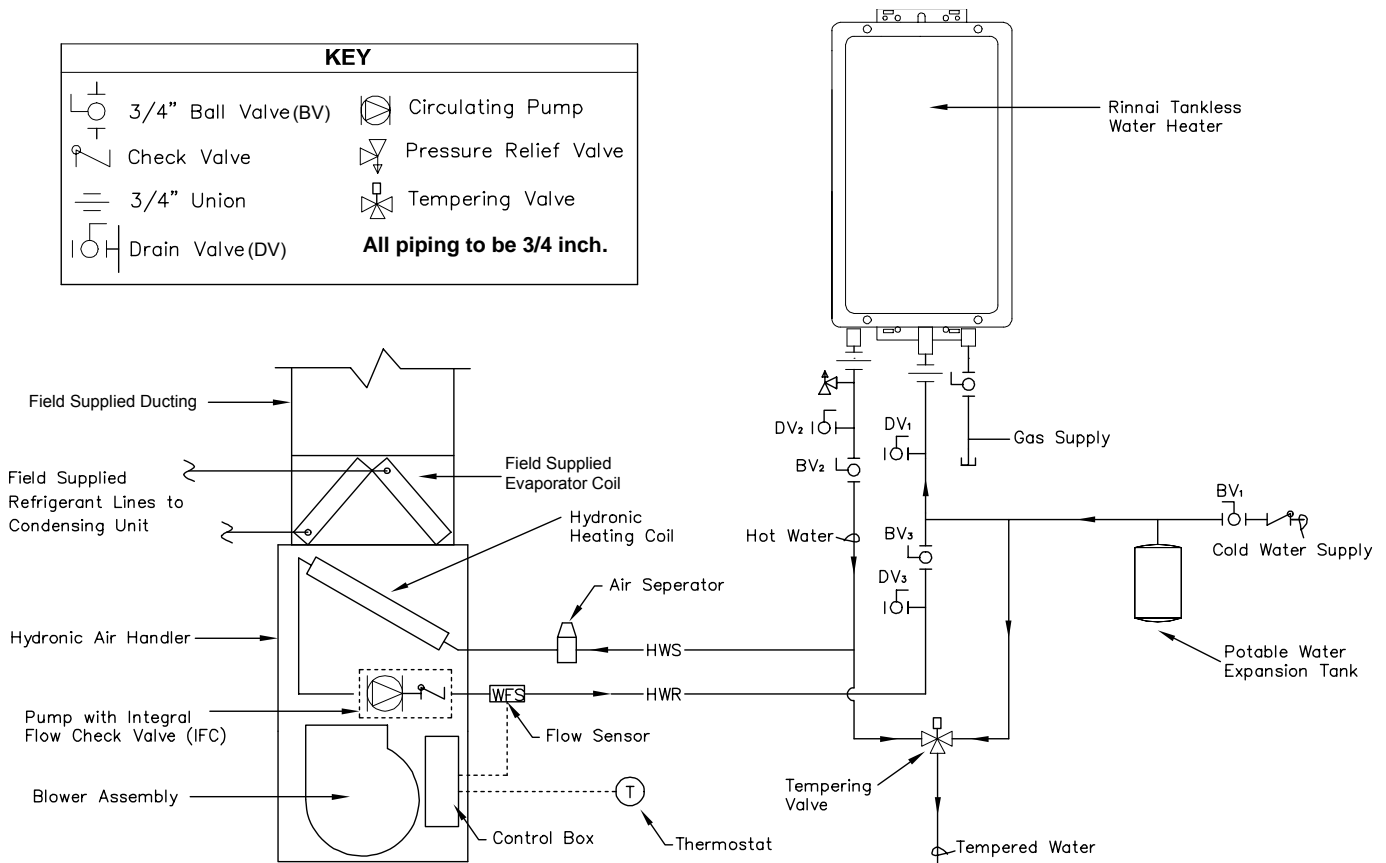
**STEP 5:** OPEN cold water supply main valve (ball valve 1 - BV<sub>1</sub>). The system will begin the prime/purge process using the street pressure. Entrapped air bubbles being pushed out of the system will be evident by a slight vibration of the discharge hose connected to drain valve 3 (DV<sub>3</sub>). The hose will stop vibrating when laminar flow is achieved.

**STEP 6:** CLOSE drain valve 3 (DV<sub>3</sub>);

**STEP 7:** OPEN ball valve 3 (BV<sub>3</sub>). The system is now purged, primed and ready to go.

**STEP 8:** OPEN the air separator venting valve.

**Note:** For an open loop system, use expansion tank approved for potable water use only.



**Figure 11** - Typical Piping Arrangement For Direct Space Heating and Domestic Water Supply with Tankless

# Installation

## ELECTRICAL CONNECTIONS

### Line-Voltage Connections:

U.S. INSTALLATIONS: Make all electrical connections in accordance with National Electrical Code (NEC) ANSI/NFPA 70 and all local codes or ordinances having jurisdiction.

CANADIAN INSTALLATIONS: Make all electrical connections in accordance with Canadian Electrical Code CSA C22.1 and all authorities having jurisdiction.

Check all factory wiring per unit wiring diagram and inspect factory wiring connections to be sure none were loosened in transit.

### ! WARNING

Before installing or servicing system, always turn off all power to system. There may be more than 1 disconnect switch. Electrical shock can cause personal injury or death.

### ! CAUTION

If a disconnect switch is to be mounted on the unit, select a location where a drill or fastener will not contact electrical or hydronic components. Electrical shock can cause personal injury or death.

**NOTE:** Prior to making any electrical connections, ensure that supply voltage, frequency, and phase are as specified on unit rating plate.

Check to ensure that the existing electrical service is adequate to handle the additional load imposed by the Hydronic Furnace. Refer to unit wiring diagram for proper electrical connections.

All electrical connections **MUST** comply with NEC and any other local codes or ordinances having jurisdiction. **USE COPPER WIRE ONLY.** Provide separate branch electric circuit with field supplied disconnect switch.

Location of disconnect switch to be in clear site, accessible and in close proximity to the unit.

Correct polarity **MUST** be maintained for 115 V wiring. If polarity is incorrect unit will **NOT** operate.

### Control Box Relocation:

The Control Box is factory installed in the blower compartment upper left corner (see Figure 12); if factory location of Control Box is suitable, proceed to next section. To relocate the Control Box to an alternate location (blower compartment upper right

side) follow steps 1 thru 7 below:

1. Remove and keep one screw and cover from the Control Box.
2. Remove and keep two screws holding Control Box to casing of 37AHA unit (See Fig. 12.).
3. Remove wire tie from looped wires attached to Control Box.
4. Before Control Box is reinstalled, remove the scored piece of insulation from the desired side. Remove two knockouts in the casing where the Control Box is to be installed.

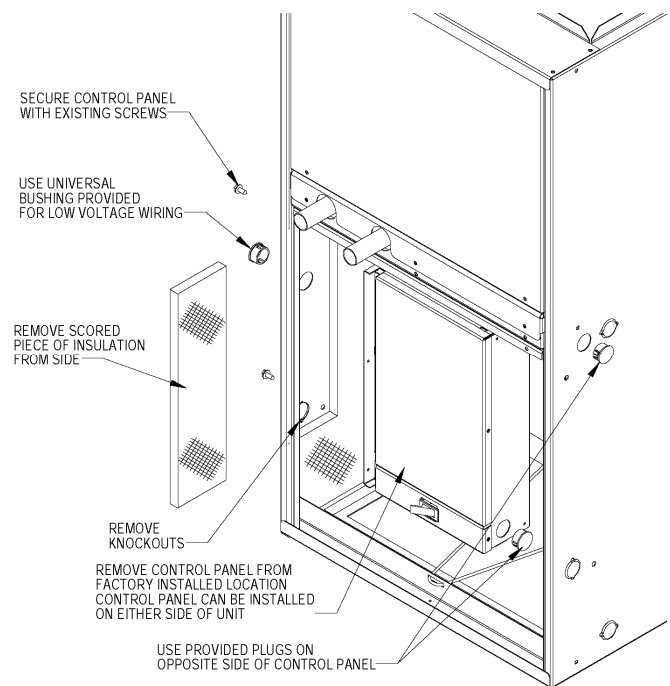


Figure 12: Control Box Relocation

### ! WARNING

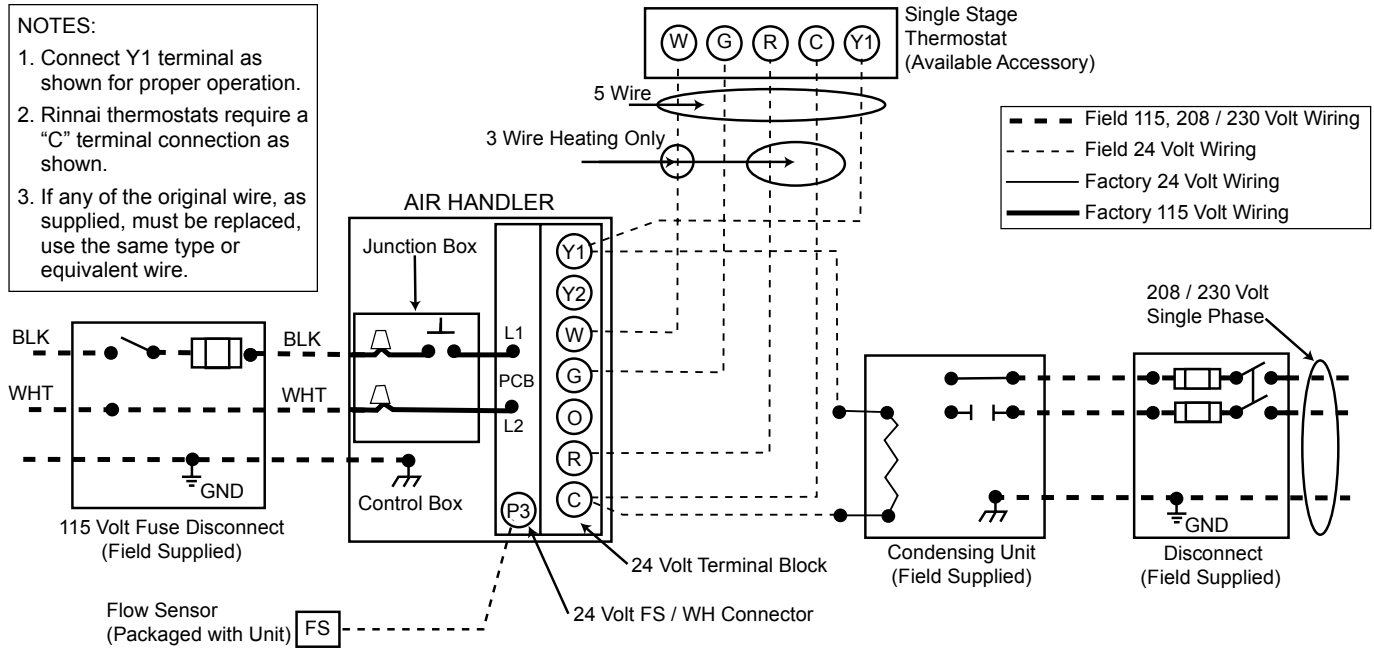
Do **NOT** remove ground screw inside control box.

5. Secure Control Box to casing with the two screws removed and kept from Step 2.
6. Reinstall two plastic plugs (from spare parts bag) where indicated in openings on adjacent side of Control Box.
7. Route Control Box wiring within unit away from hot surfaces, sharp edges and rotating parts.

# Installation

## NOTES:

1. Connect Y1 terminal as shown for proper operation.
2. Rinnai thermostats require a "C" terminal connection as shown.
3. If any of the original wire, as supplied, must be replaced, use the same type or equivalent wire.



**Figure 13:** Field Wiring Diagram

### Electrical Connection to Control Box

1. Route the furnace power wires through aligned holes in casing and Control Box and make field wire connections in Control Box. Use best practices for wire bushings, strain relief, etc. Field wiring to the unit must be grounded and conform to the National Electrical Code C22.1 Part 1 - latest edition. Use only UL listed conduit and conduit connectors to connect supply wires to the unit and provide appropriate grounding. Grounding may also be accomplished by grounding the control box per appropriate local codes. Electric wires that are field installed shall conform to the temperature limitation for 63° F (35° C) rise wire when installed in accordance with instructions. Refer to Table 3 in for specific furnace electrical data.
2. Route and secure field ground wire to ground screw on Control Box.
3. Connect line voltage leads as shown in Figure 13.
4. Reinstall cover to Control Box. Ensure that wires are not pinched between cover and edge of Control Box.

### 24V Control System Connections to Unit's Printed-Circuit Board (PCB):

Refer to Figures 25 through 27 for factory wiring details. For low voltage connections between the unit and the thermostat, use No. 18 AWG color-coded, insulated (63° F / 35° C minimum) wires. (Refer to Figures 16 through 19.)

### Low Voltage Connections:

These units use a grounded 24 volt AC low voltage circuit and require at least a 1 stage heating and a 1 stage cooling thermostat.

The "R" terminal is the hot terminal and the "C" terminal is grounded.

"G" terminal is the fan input.

"Y1" terminal is the compressor Stage 1 input.

"Y2" terminal is the compressor Stage 2 input.

"O" terminal is the reversing valve input. The reversing valve must be de-energized for heating mode.

"R" terminal is 24 VAC hot.

"C" terminal is 24 VAC grounded.

"W" terminal is the heat input. This terminal also energizes the emergency heat if configured for heat pump.

## ⚠ WARNING

Failure to follow this warning could result in a fire. Do not use aluminum wire between the Hydronic Furnace and the disconnect switch. USE COPPER WIRE ONLY.

# Installation

## System Low Voltage Wiring Diagrams

**NOTE:** Local codes may require thermostat wiring to be routed through conduit or raceways. In such instances splices can be made inside the Hydronic Furnace. All wiring must be NEC Class I and must be separated from incoming power leads.

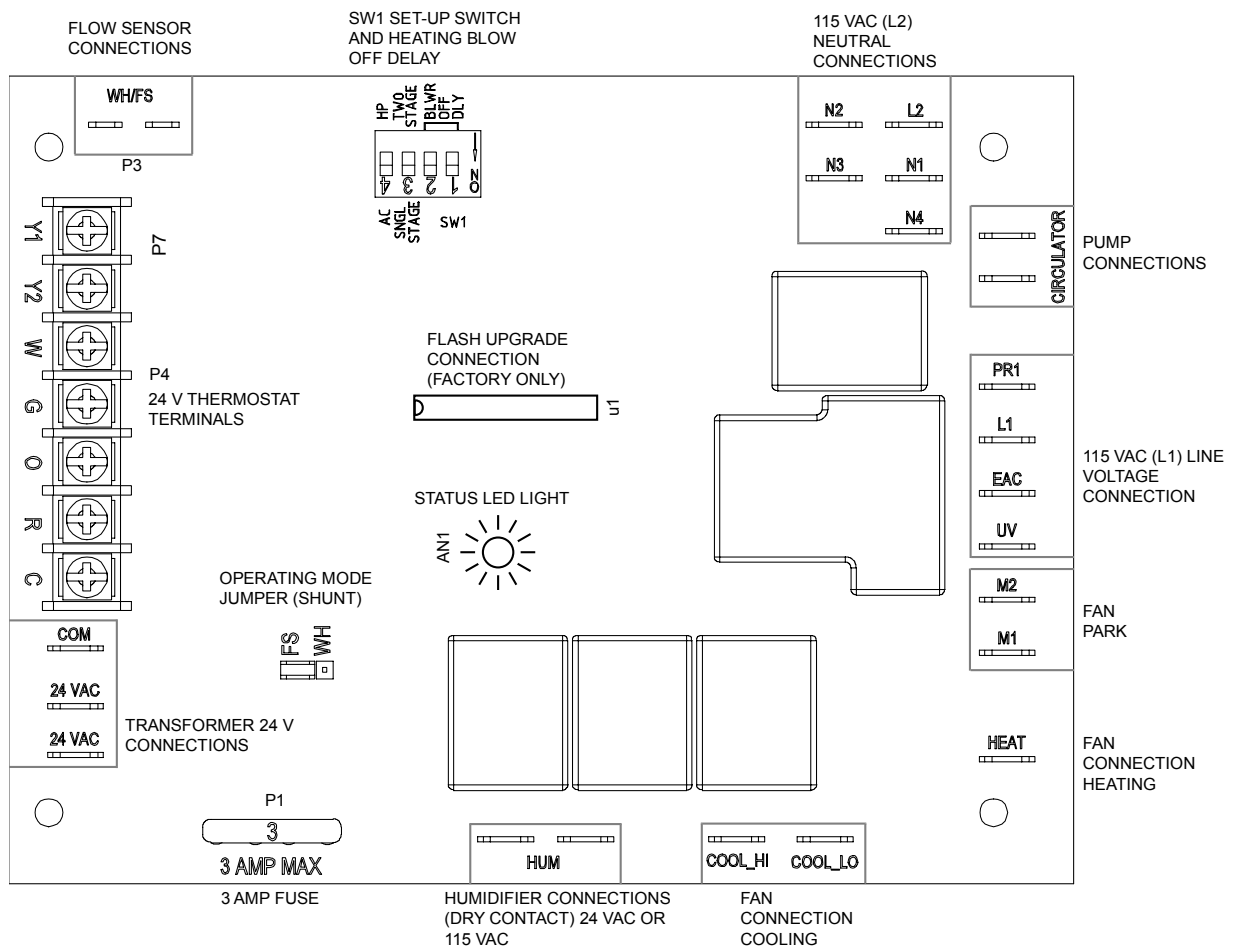
Provide field supplied disconnect. Refer to Table 3 (Specifications) for maximum fuse or circuit breaker sizes.

Transformer is factory wired for 115v operation. (See Figures 25 through 27 .)

The secondary circuit of the transformer is protected by a 3-amp fuse mounted on the printed-circuit board.

**IMPORTANT:** Where possible, use a Rinnai factory authorized thermostat with the 37AHA series Hydronic Furnaces. If a thermostat other than specified is used then refer to the manufacturer's installation instructions.

Wire Gauge	Maximum Distance (feet)
20 gauge	45
18 gauge	60
16 gauge	100
14 gauge	160
12 gauge	250



**Figure 14:** Hydronic Furnace Control Board

Notes:

1. For proper operation of an open loop system (refer to Figures 11 and 14), the jumper (shunt) position on PCB point "P7" should be in the FS position.
2. When changing shunt position ensure that unit power is turned off.



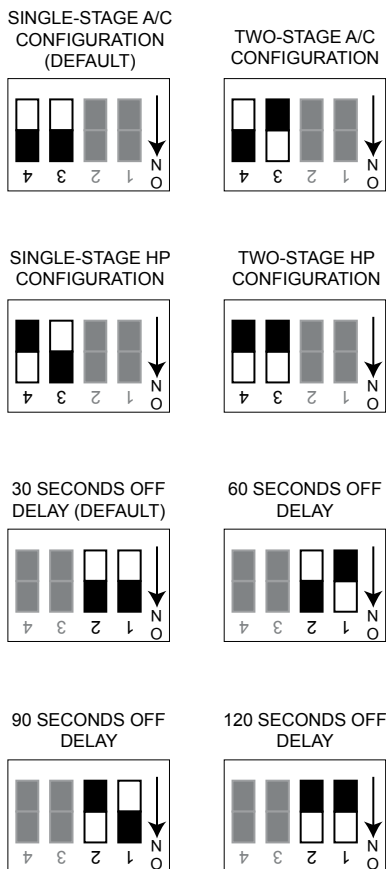
# Installation

## Dip Switch Options (Smart Operating System):

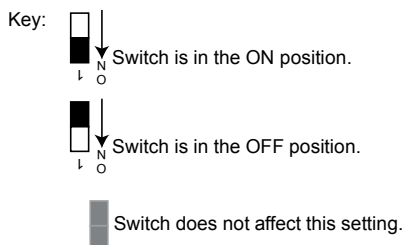
The Rinnai® exclusive Smart Operating System is a feature of your 37AHA series Hydronic Furnace's control system that is designed to allow the installer (via DIP Switch – SW1) to configure the unit for single or two stage, A/C or Heat pump systems with selectable heat bower off delay.

Refer to Figures 14 and 15 and the appropriate diagram for the proper dip switch setting to be used with the designed application.

When viewed with the Furnace in the upflow position, the dip switch will as shown below (upside down).



**Figure 15:** Dip Switch Positions



## THERMOSTAT INSTALLATION:

### Safety Considerations:

All wiring must conform to local and national electrical codes. Improper wiring or installation may damage thermostat.

## WARNING

Before installing thermostat, turn off all power to unit. There may be more than one power disconnect. Electrical shock can cause personal injury or death.

### INSTALLATION CONSIDERATIONS:

#### Air Conditioner Model:

The Standard Model A/C thermostat may be wired with or without connecting a common wire between the indoor equipment and the thermostat. However, it is recommended to use a common wire whenever possible. Without a common wire this thermostat becomes "power stealing." This means it will need to steal a small amount of power from the equipment to which it is connected. When "power stealing" connection is used, the supplied 270 ohm resistor must be connected at the indoor unit.

#### Heat Pump Model:

The Standard Model HP thermostat is not "power stealing" and MUST have both 'R' and 'C' wires connected to operate properly. This thermostat uses a green LED to indicate auxiliary/emergency heat operation.

#### Installation:

Thermostat should be mounted

- approximately 5 ft. (1.5 m) from floor
- close to or in a frequently used room, preferably on an inside partitioning wall
- on a section of wall without pipes or duct work.

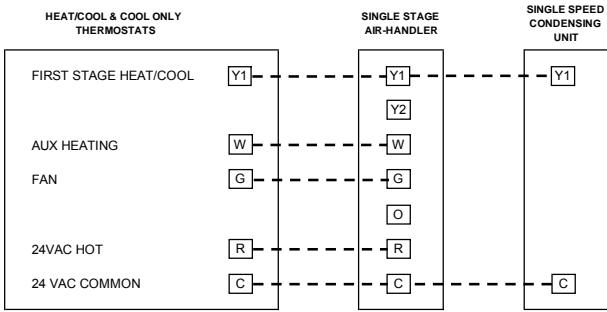
Thermostat should NOT be mounted

- close to a window, on an outside wall, or next to a door leading to the outside.
- exposed to direct light and heat from a lamp, sun, fireplace, or other heat-radiating object which may cause a false reading.
- close to or in direct airflow from supply registers and return-air grilles
- In areas with poor air circulation, such as behind a door or in an alcove

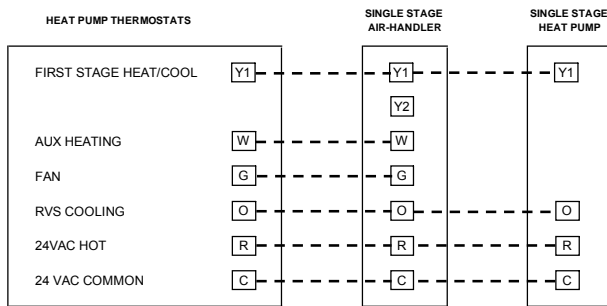
Refer to Figures 16 through 19 for thermostat wiring diagram and thermostat installation instructions for further details.

# Installation

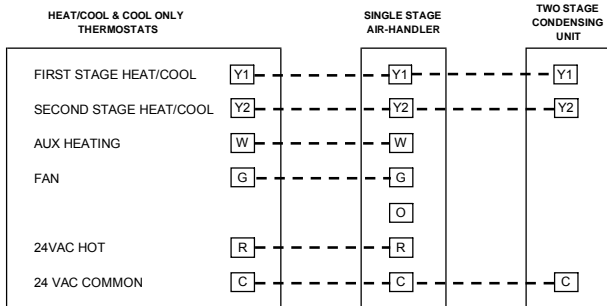
## THERMOSTAT WIRING DIAGRAMS



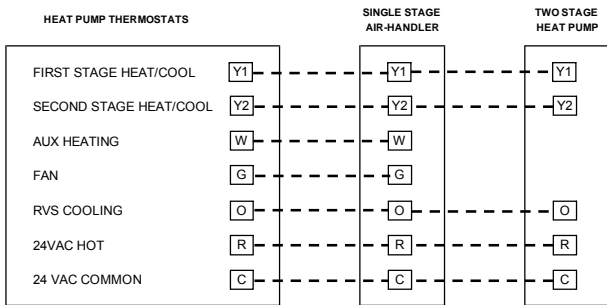
**Figure 16** Single Stage Air Handler w/ Single Stage A/C



**Figure 17** Single Stage Air Handler w/ Single Stage Heat Pump



**Figure 18** Single Stage Air Handler w/ Two Stage A/C



**Figure 19** Single Stage Air Handler w/ Two Stage Heat Pump

### Shunt Jumper Options:

An additional feature of the 37AHA series is its selectable operating sequence option; the 3-pin shunt header (P7) allows the control to operate the proper heating logic based on the following system requirements:

The 37AHA unit in Open Loop configuration:

“FS” Shunt selection: The “FS” logic sequence will configure the unit for operation with all Rinnai® V and VA series Tankless Water Heaters; this logic monitors the ratio of available flow for space heating (via Flow Sensor); this status is then communicated to the PCB whose operating characteristics is primarily determined by the status of the Flow Sensor input (sequence allows domestic priority).

## WARNING

Failure to follow this warning could result in an electrical shock, fire, or death. To minimize personal injury if an electrical fault should occur, cabinet grounding **MUST** be an uninterrupted ground and **MUST** comply with NEC, ANSI/NFPA 70 and all local codes having jurisdiction. The ground may consist of electrical wire or metal conduit when installed in accordance with existing electrical codes.

# Installation

## START-UP PROCEDURE (HEATING ONLY):

The following conditions must be met prior to unit start-up.

Debris from soldering and/or other installation activities can cause equipment failure. Ensure that all associated lines and appurtenances are free of debris.

Check to ensure that unit is secure.

Check that blower wheel rotates freely within the scroll housing.

Check all wiring to ensure that connections are tight.

Check all ductwork and pipe connections to ensure proper seal.

Check to ensure that all packaging wraps are removed from equipment.

Ensure that front access doors are properly installed.

Check to ensure proper connection(s) to the appropriate blower speed tap (Heat /Cool – High and Low). Refer to Dry Air Delivery Table and/or the appropriate wiring diagram(s) in this manual.

Perform all safety and start-up checks for Tankless Water Heater as per manufacturer's instructions.

Having verified all preceding checks, the Furnace's Start-Up Procedure is as follows:

**STEP 1:** Purge and fill system; follow appropriate purging procedure as laid out in this manual in section titled "Purging and Priming the System".

**STEP 2:** Turn on power supply to furnace. Caution: blower and/or circulator may start to operate if thermostat is on and a call is present.

**STEP 3:** Turn thermostat on and switch system to the heating mode. The thermostat shall be set higher than the actual room temperature; this will cause the circulator to energize and initiate the heating cycle. (If the pump does not start, or the Furnace is not producing heat, refer to the Troubleshooting Section in this manual).

**STEP 4:** Program room thermostat as desired by homeowner.

## START-UP PROCEDURE (COOLING SYSTEM)

Refer to field supplied evaporator coil and outdoor unit manufacturer's Installation Instructions for system hook-up, start-up instructions and refrigerant charging method details.

## TROUBLESHOOTING BLOWER AND/OR PUMP MOTOR AND CONTROLS

### CAUTION

High voltage is at all times present at motor. Disconnect power to AHU before removing or replacing or servicing motor. Wait at least 5 min after disconnecting power before opening motor. Failure to follow this CAUTION could result in minor personal injury or product and property damage.

#### If blower and/or pump motor does not run:

Turn off power and check the following:

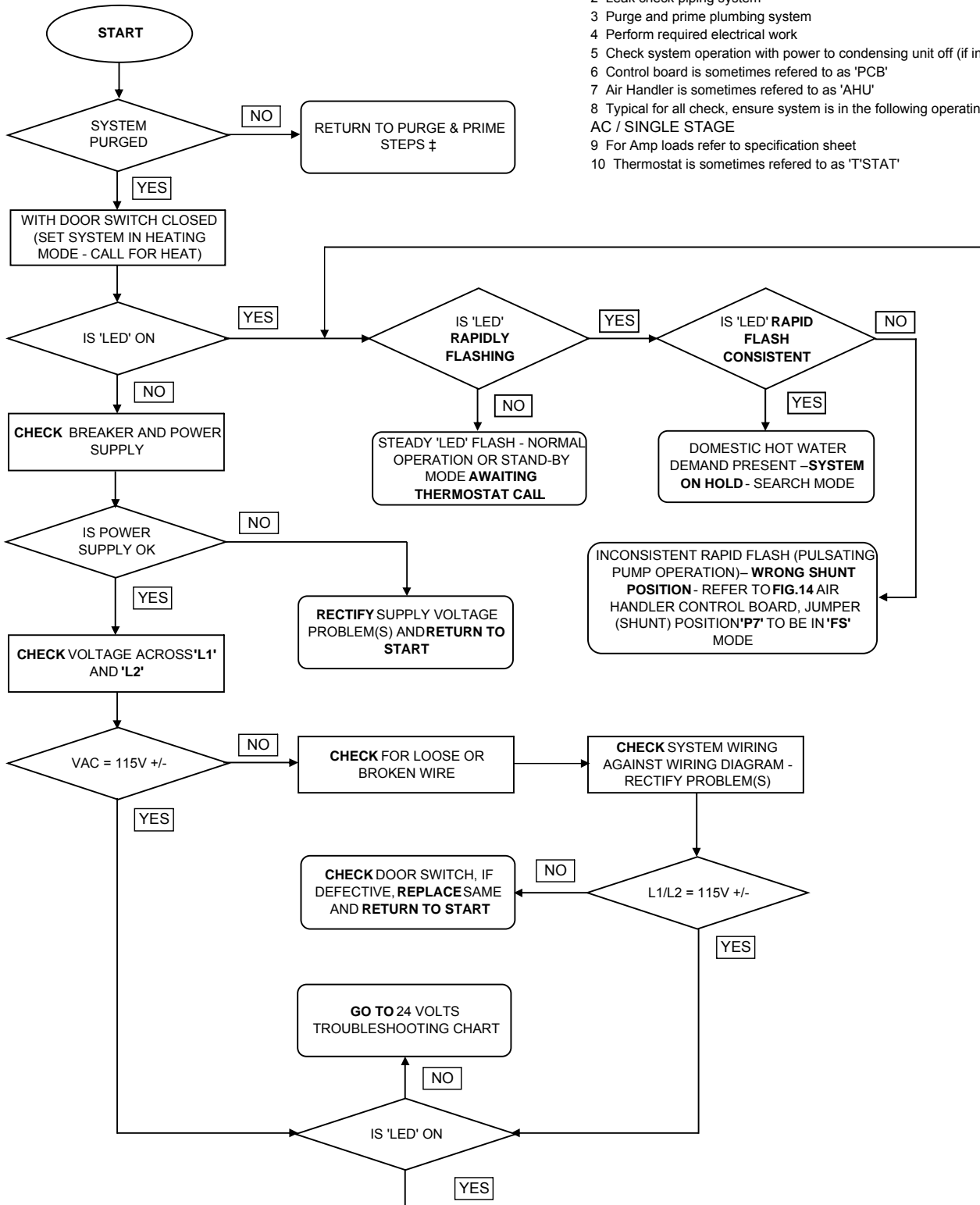
1. Check that door switch is in the CLOSED position.
2. Check 3 amp fuse on Printed Circuit Board (PCB).
3. Check for 24 VAC between COM and 24 VAC on PCB. If no voltage is present, check transformer.
4. Check all connections for kinks which could cause loose connections. Ensure connections are secure.
5. Verify that approximately 120 VAC is present across L1 and L2.

If system still fails to start, refer to Figures 20 through

# Installation

## NOTES:

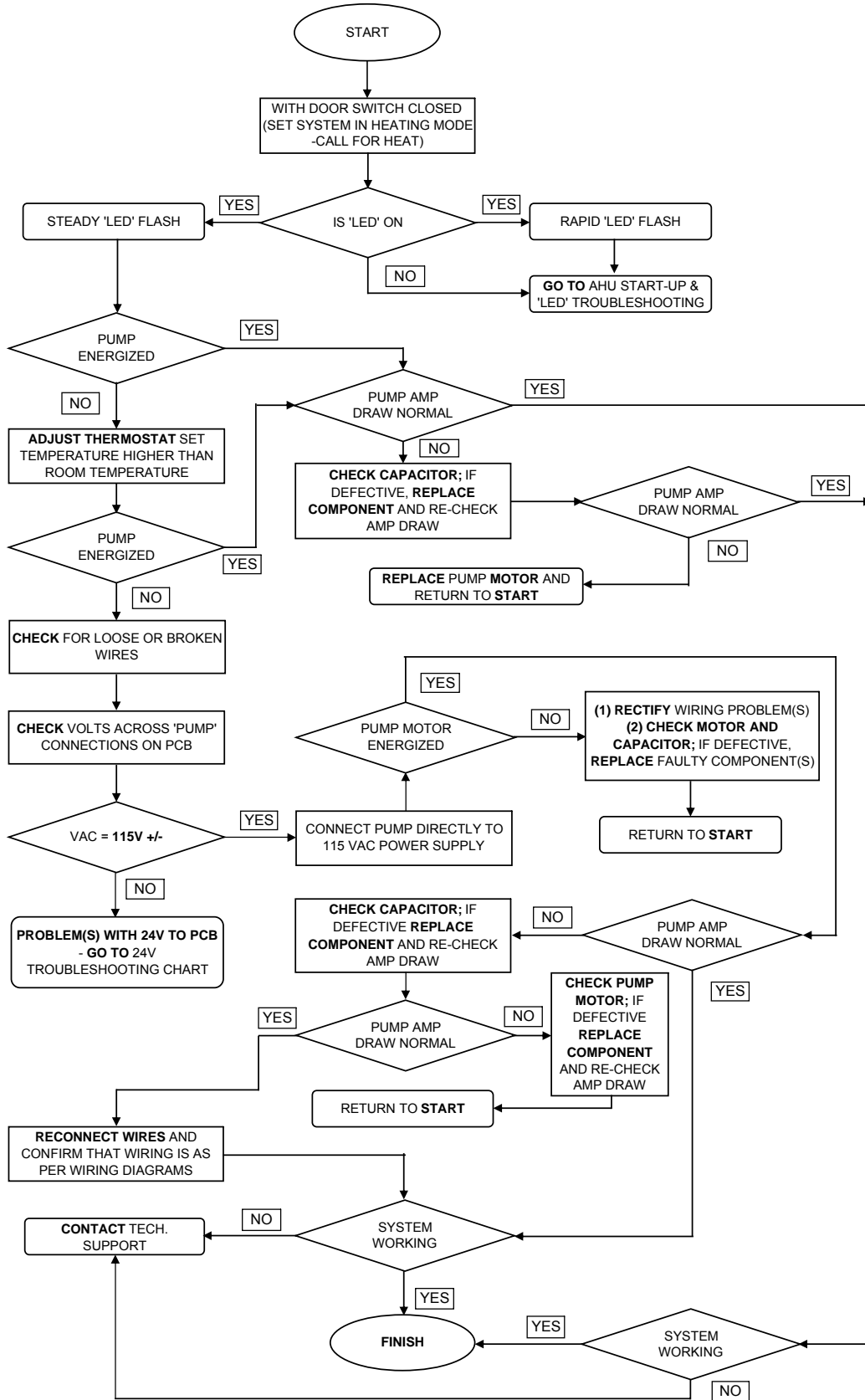
- 1 Pipe system between Tankless Water Heater and Air Handler ‡
- 2 Leak check piping system
- 3 Purge and prime plumbing system
- 4 Perform required electrical work
- 5 Check system operation with power to condensing unit off (if installed)
- 6 Control board is sometimes referred to as 'PCB'
- 7 Air Handler is sometimes referred to as 'AHU'
- 8 Typical for all check, ensure system is in the following operating mode:  
AC / SINGLE STAGE
- 9 For Amp loads refer to specification sheet
- 10 Thermostat is sometimes referred to as 'T'STAT'



‡ Refer to plumbing section in this manual

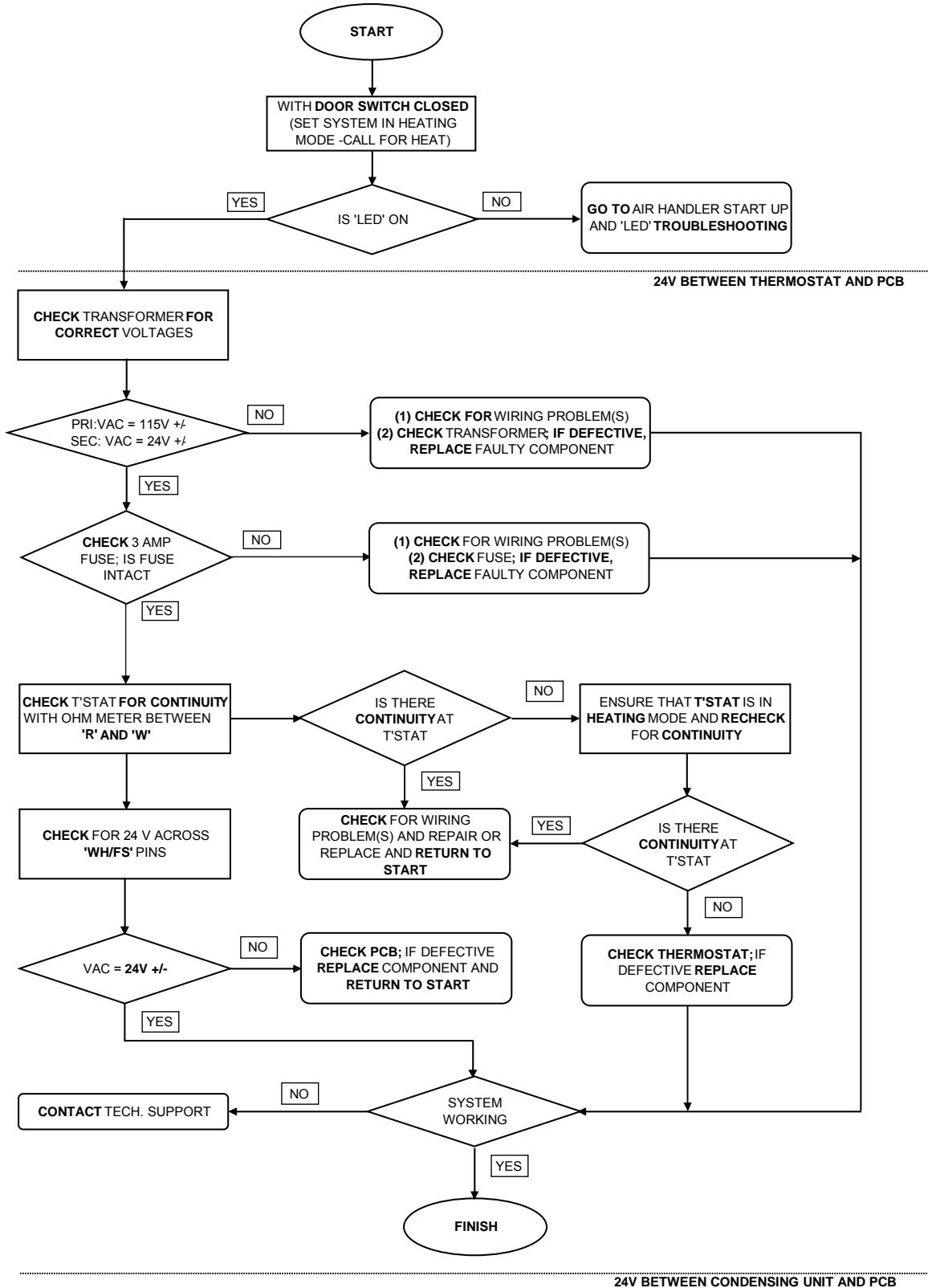
**Figure 20:** Hydronic Furnace Start-Up and 'LED' Troubleshooting - Flow Sensor (FS Configuration)





**Figure 22:** Circulating Pump 115V Troubleshooting - Flow Sensor (FS) Configuration

# Installation



If a condensing unit and cased coil set is used in conjunction with the Rinnai Air Handler for cooling, refer to air conditioning manufacturer's instructions for hook-up and troubleshooting details.

**Figure 23:** 24V Troubleshooting - Flow Sensor (FS) Configuration

# Sequence of Operation

## SEQUENCE OF OPERATION:

**NOTE:** Furnace control must be grounded for proper operation; control is grounded through green wire routed to control box screw.

## STANDBY MODE:

All control outputs are off and the control is waiting for a thermostat demand. The control initiates action when a thermostat call is received.

## COOLING MODE:

### Single-Stage Air-Conditioning (A/C) Cooling Demand:

When the thermostat calls for cooling (Y), the control energizes the COOL\_HI blower tap after a 1 second on delay period.

When the thermostat removes the call for cooling (Y), the control de-energizes the COOL\_HI blower tap after a cooling off delay period of 30 seconds.

A call for cooling has priority over a thermostat blower demand.

If a call for heat (W) exists with a call for cooling, the call for heat shall proceed as normal except the blower remains energized on the COOL\_HI speed tap. If the call for cool goes away while a call for heat exists, the cooling off delay is canceled and the blower operation reverts to the heat cycle.

### Two-Stage A/C Cooling Demand:

When the thermostat calls for cooling (Y), the control waits for a 1 second cooling on delay period and energizes the COOL\_LO blower tap. If a 2<sup>nd</sup> stage cooling (Y2) call is sensed, the control de-energizes the COOL\_LO blower tap and energizes the COOL\_HI blower tap after a 1 second delay.

When the thermostat removes the call for 2nd stage cooling (Y2), the control de-energizes the COOL\_HI blower tap and energizes the COOL\_LO blower tap. When the thermostat removes the call for cooling (Y), the control de-energizes the COOL\_LO blower tap after a cooling off delay period of 30 seconds.

If a call for heat (W) exists with a call for 2nd stage cooling, the call for heat shall proceed as normal except the blower remains energized on the COOL\_HI speed. If the call for cool goes away while a call for heat exists, the cooling off delay is canceled and the blower operation reverts to the heat cycle.

### Single-Stage Heat-Pump (HP) Cooling Demand:

When the thermostat calls for cooling (Y and O), the control waits for the 1 second cooling on delay period and energizes the COOL\_HI blower tap.

When the thermostat removes the call for cooling (Y and O), the control de-energizes the COOL\_HI blower tap after a cooling off delay period of 30 seconds.

A call for cooling has priority over a thermostat blower demand.

If a call for emergency heat (W) exists with a call for cooling, the call for heat shall proceed as normal except the blower remains energized on the COOL\_HI speed tap. If the call for cool goes away while a call for emergency heat exists, the cooling off delay is canceled and the blower operation reverts to the heat cycle.

### Two-Stage HP Cooling Demand:

When the thermostat calls for cooling (Y and O), the control waits for the 1 second cooling on delay period and energizes the COOL\_LO blower tap. If a second stage cooling (Y2) call is sensed, the control de-energizes the COOL\_LO blower tap and energizes the COOL\_HI blower tap after the 1 second delay.

When the thermostat removes the call for 2nd stage cooling (Y2), the control de-energizes the COOL\_HI blower tap and energizes the COOL\_LO blower tap. When the thermostat removes the call for cooling (Y), the control de-energizes the COOL\_LO blower tap after a cooling off delay period of 30 seconds.

If a call for emergency heat (W) exists with a call for 2nd stage cooling, the call for heat shall proceed as normal except the blower remains energized on the COOL\_HI speed. If the call for cool goes away while a call for emergency heat exists, the 2nd stage cooling off delay is canceled and the blower operation reverts to the heat cycle.

## HEATING MODE:

### Heating Operation: Air-Conditioning (A/C) Mode - Configured for Flow Sensor (FS) Input:

#### Circulating Pump Operation:

On a call for heating, terminal "W" of the thermostat is energized. The control monitors the FS input and energizes the circulating pump if the FS signal is present.



## Sequence of Operation

If the FS signal is NOT present, the control will energize the circulating pump for 60 seconds in an attempt to activate the Flow Sensor (FS). If the FS signal does not become active during the time, the control will de-energize the circulating pump for 60 seconds and then start another 60 seconds with the circulating pump energized to try to activate the Flow Sensor. Sequential attempts to activate the Flow Sensor will use 60 second, 120 second and 180 second de-energized periods for the circulating pump. The de-energized period will circle back to the original 60 second off period following sequential unsuccessful energized attempt to activate the Flow Sensor. During this time the Status LED will rapidly flash, indicating that a heat demand is present, but not being satisfied because of the state of the FS input signal.

### Heat Blower ON Delay:

The control waits for 25 seconds after the circulator pump is energized (and FS signal is present) and then energizes the indoor blower heat speed and the humidifier output.

If the thermostat demand for heat is removed, the control de-energizes the circulating pump, and runs the heat speed blower and humidifier through the selected blower off delay as defined by the dip switch settings in Figure 15.

### Steady Heat:

Control inputs are continuously monitored to ensure the call for heat remains.

If the thermostat demand for heat is removed, control operation proceeds to the operation described in “*Heat Blower ON delay*” section above.

If the FS input becomes absent during steady state heating, the sequence in “*Circulating Pump Operation*” section above will become active and the blower off delay will run.

If the FS input signal returns within the same heating demand period (W), the control will begin jogging the circulator pump as described in “*Circulating pump Operation*” section, normal heating operation will resume.

### Heat Blower OFF Delay:

When the heating thermostat demand (W) is removed, the control de-energizes the circulating pump and then de-energizes the indoor blower motor and humidifier after a delay time as defined by the dip switch settings in Figure 15.

Blower timing begins when the thermostat is satisfied. The control returns to standby when the blower off time is complete.

If the thermostat call for heat returns before the blower off delay is complete, the control re-energizes the circulating pump and resumes a normal heating sequence.

### Heating Operation: Heat-Pump (HP) Mode - Configured for Flow Sensor (FS) Input:

#### Single-Stage HP Demand - Call for Heat:

The thermostat calls for heat by connecting (Y and R). The control will proceed to the Heat Blower ON Delay when a single stage heat demand exists.

The Heat Pump is the primary source of heating in this mode.

#### Blower ON Delays:

The control waits for 1 second and then energizes the COOL\_HI tap if and the humidifier output. If the thermostat demand for heat is removed, the control runs the COOL\_HI tap and humidifier through a fixed 30 second blower off delay.

#### Steady Heat:

Control inputs are continuously monitored to ensure the call for heat remains.

If the thermostat demand for heat is removed, control operation proceeds to the operation described in the “*Blower On and Off Delays*” section.

The Heat Pump is the primary source of heating in this mode.

#### Second Stage HP Demand – Call for Heat:

After the control enters into a Steady Heat mode, the second stage heating demand (Y2) input is monitored. If a (Y2) demand is sensed, the COOL\_HI blower speed will be energized. If the (Y2) demand becomes absent, the COOL\_HI blower speed will immediately be de-energized and the COOL\_LO blower speed will again be energized.

#### Heat-Pump Emergency Heat Demand:

The Emergency Heat (W) input is continually monitored, and is a higher priority than single or 2-stage heating demands. If the Flow Sensor (FS) input signal is present with a call for emergency heat (W), the circulator pump will immediately be energized.

## Sequence of Operation

If the FS input signal remains (indicating that there is adequate hot water flow) the circulator pump will remain energized, the HEAT blower speed and HUM outputs will then be energized. If the emergency heat demand (W) is removed, the HEAT blower speed will immediately be de-energized and the blower will return to the appropriate speed based on any remaining thermostat demand.

If the FS signal is NOT present, the control will energize the circulating pump for 60 seconds in an attempt to activate the Flow Sensor (FS). If the FS signal does not become active during the time, the control will de-energize the circulating pump for 60 seconds and then start another 60 seconds with the circulating pump energized to try to activate the Flow Sensor. Sequential attempts to activate the Flow Sensor will use 60 second, 120 second and 180 second de-energized periods for the circulating pump. The de-energized period will circle back to the original 60 second off period following sequential unsuccessful energized attempt to activate the Flow Sensor. During this time the Status LED will rapidly flash, indicating that a heat demand is present, but not being satisfied because of the state of the FS input signal.

If the FS input signal again becomes present within the same emergency heating demand (W), the pump will begin jogging (as described in the above paragraph), normal emergency heating operation will resume.

### Heat Blower OFF Delay:

When the heating thermostat demand is removed, the control immediately de-energizes the circulating pump and then de-energizes the indoor blower motor and humidifier after a fixed 30 second blower off delay. Blower timing begins when the thermostat is satisfied. The control returns to standby when the blower off time is complete.

If the thermostat call for emergency heat returns before the blower off delay is complete, the control resumes an emergency heating sequence as defined.

### Off Season Circulation Timer

All Rinnai® AHU models are equipped with a circulation timer. It is normal operation for these models to automatically run the circulation pump for a period of two minutes intermittently every six hours if there has not been a call for heat within the said six hours.

The unit also incorporates the unique feature of learning the household schedule to determine the best six hour intervals (periods of least flow interruption) to run the circulator timer.

## Maintenance

Repairs should be performed by a qualified service technician. The appliance should be inspected annually by a qualified service technician. Verify proper operation after servicing.

### CLEANING

It is important that compartments, filter, and circulating air passage ways of the appliance be kept clean. Clean as follows:

1. Turn off and disconnect electrical power. Allow to cool.
2. Replace the air filter. (Should be done at least quarterly. Refer to the Specifications section for sizes.)
3. Use pressurized air to remove dust from the components.
4. Use soft dry cloth to wipe cabinet.

### SUPPLY AND RETURN AIR DUCT SYSTEMS

The supply and return air ducts should be inspected at least annually for blockages or damage.

### MOTORS

The motor and pump are permanently lubricated and do not need periodic lubrication. Keep free of dust and dirt by cleaning annually.

### INTEGRAL CIRCULATOR PUMP

#### Replacing Pump Motor Assembly:

1. Disconnect the electrical supply.
2. Reduce system pressure to 0 psi and allow system to return to room temperature. Isolate the circulator by closing the service valves or draining the system.
3. Remove the body bolts and swing motor assembly away from the body.

## Maintenance

4. Install new motor, and reassemble circulator using the new gasket and bolts supplied.
5. Follow the “installation” procedure to start up the circulator.

### Replacing Pump Cartridge Assembly:

1. Disconnect the electrical supply.
2. Reduce system pressure to 0 psi and allow system to return to room temperature. Isolate the circulator by closing the service valves or draining the system.
3. Remove the body bolts and swing motor assembly away from the body.
4. Pull cartridge out of the motor housing.

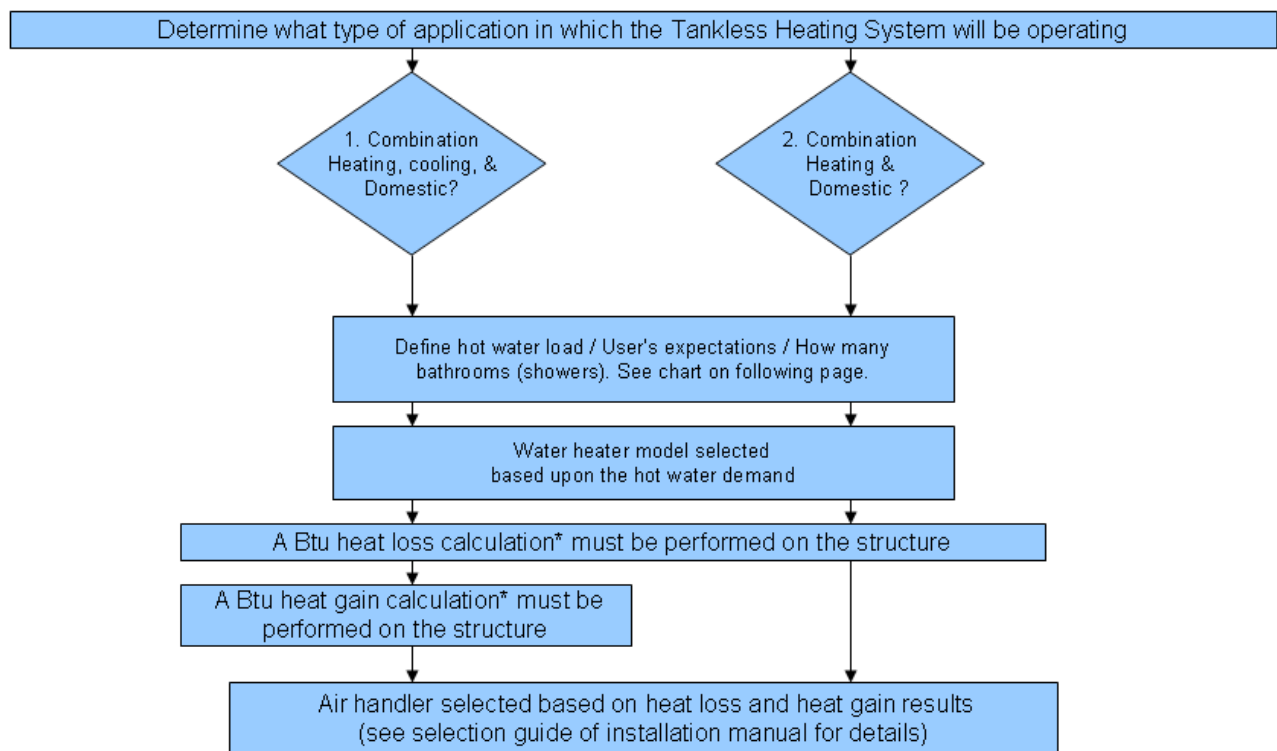
5. Install replacement cartridge, making sure that the cover plate is between the cartridge flange and motor.
6. Make sure the replacement cartridge corresponds to the full circulator product number. A complete parts list is available from your local distributor.
7. Reassemble the circulator using the new gasket and bolts supplied.
8. Follow the “Installation” procedure to start up the circulator.

### Replacing Pump Capacitor:

1. Replacement capacitor must have same rating as originally furnished.

## Selection Guide

### Hydronic Air Handler and Tankless Water Heater Sizing Guidelines



Btu heat loss and heat gain calculations are comprehensive evaluations on a structure's ability to retain heat. Please visit [www.acca.org/tech/manual/](http://www.acca.org/tech/manual/) for more information.

**Figure 24:** Hydronic Furnace and Tankless Water heater Sizing Guidelines

# Selection Guide

## SELECTION PROCEDURE (WITH EXAMPLE)

### I. Define hot water load for the total required domestic hot water usage.

To help with the sizing and selection of your new Rinnai Tankless Water Heater (TWH), refer to our website at: <http://www.foreverhotwater.com/> or contact Rinnai's Application Engineering Department at: **1-800-621-9419**

As an example let's assume that the selected Rinnai Tankless Water Heater for your whole house solution is the REU-V2020WC (C53) and your calculated heat gain and heat loss values are as stated in section II.

### II. Determine cooling and heating requirements at design conditions:

The ACCA's Manual J Residential Load Calculation method is the established trade standard, approved by ANSI, for the correct sizing and selection of Heating, Ventilation, Air-Conditioning and Refrigeration (HVACR) equipment in residential homes. The most recent revision is the eighth edition, an all-inclusive new approach to ensuring that Indoor Air Quality (IAQ) systems are as efficient, safe, and healthy as possible. Refer to the Air Conditioning Contractors of America website at: <http://www.acca.org/tech/manualj/> or a qualified HVACR contractor for further assistance.

Assumptions:

Required Cooling Capacity .....	34,500 Btuh (Total Capacity)
Required Heating Capacity.....	60,000 Btuh
Evaporator Air Quantity.....	1200 CFM
External Static Pressure.....	0.2 in. WC
Electrical Characteristics.....	115-1-60

### III. Determine total external static pressure (ESP) at design conditions:

Before using the Dry Coil Air Delivery Table 4, calculate the total static pressure required. From the given example, note the Wet Coil Pressure Drop (selected from the field supplied Evaporative Cased Coil Installation Instructions), and the Filter Pressure Drop. Determine both static pressures at 1200 CFM:

Wet Coil Pressure Drop.....	0.21 in. WC (From Coil Manufacturer's Installation Instructions).
External Static Pressure.....	0.2 in. WC (Ductwork etc.)
Filter Pressure Drop.....	0.0 in. WC (0.0 inches if the included Rinnai filter is used; 0.08 if another filter is used. Refer to the filter's manufacturer's instructions).
Total Static Pressure.....	0.49 in. WC

### IV. Select unit based on required cooling capacity airflow:

For an initial selection, choose a unit size that will provide the required airflow. Refer to Table 4 Dry Coil Air Delivery. Note that at 0.5 ESP (external static pressure) the 37AHA06012KA5 unit will deliver 1240 cfm when configured for HIGH Speed.

### V. Select heating capacity of unit to provide the requisite design condition.

From the Hydronic Furnace Output table for the 37HAH045 & 060 units (Table 5), note that the unit 37AHA06012KA5 (as selected above) when matched with the REU-V2020WC (C53) TWH will provide 61.1 MBH (61,100 Btuh) at an input water temperature (to furnace) of 150 °F.

### VI. Select unit that corresponds to power source available:

Refer to Model Number Nomenclature; note the eleventh digit denotes the voltage code; therefore the "K" model (37AHA06012KA5) unit is the unit that should be selected for the above stated hypothetical conditions. This unit is designed to operate at 115/120-1-60.

### Table 3: Hydronic Furnace Specifications

UNIT MODELS		37AHA04508KA5	37AHA06012KA5	37AHA07514KA5	37AHA09016KA5
Trade Name		AH45	AH60	AH75	AH90
RATING AND PERFORMANCE		Descriptor (Typ.)			
Nominal Output Capacity (BTU/h) †		45,000	60,000	75,000	90,000
Air Side Temperature Rise Rate in °F (68°F Entering Air @ 150°F Entering Water)		Heat Speed	50	50	50
External Static Pressure		(in. W.C.)	0.5	0.5	0.5
Nominal Airflow (CFM)		Heating	800 ‡	1200 ‡	1400 ‡
		Cooling Range	650 - 800	650 - 1200	1000 - 1600
1600 ‡		1200 - 1750			
ELECTRICAL					
Power Supply		V - HZ - PH	115-60-1		
Minimum Circuit Ampacity		MCA	6.3	8.7	13.7
Max. Rating of Overcurrent Protective Device		MOP (Calculated)	9.9	14.2	23.2
Maximum Fuse or CKT BKR Size		Amps	15	15	20
Transformer (24V)			40 VA (Primary: 120 VAC / Secondary: 24 VAC)		
Printed Circuit Board		PCB	INTEGRAL (with connections for A/C system, UV lamp, Humidifier, and electronic air cleaner)		
CONTROLS					
Available Unit Configurations		A/C or HP	Dip Switch Selectable (SW1)		
		Single or Two Stage	Dip Switch Selectable (SW1)		
		FS or WH	Shunt Selectable (P-7)		
Safety Door Switch		Rated Voltage	125 VAC		
		Resistive Load	21 Amp		
Blower Off Delay		HTG/CLG	Dip-switch Selectable/Fixed 30 Sec		
Cool / Heat Blower On Delay		Varies	Cool: 1 second / Heat: 25 seconds (see Sequence of Operations)		
INDOOR BLOWER MOTOR					
Type			DIRECT DRIVE MOTOR (PSC)		
Motor HP			1/3	1/2	3/4
Motor (Rated Load Amps/Locked Rotor Amps)		RLA/LRA	3.6 / 11.0	5.5 / 18.2	9.5 / 21.5
Run Capacitor		mfd/volts	10/370		25/370
Volts-PH-HZ			115-1-60		
CIRCULATING PUMP					
Type			Wet Rotor		
Volts-PH-HZ			115-1-60		
Motor (Full Load Amps/Locked Rotor Amps)		FLA/LRA	1.8 / 2.6		
Pump Motor HP			1/8		
Run Capacitor		mfd/volts	14/250		
Maximum Working Pressure		PSI	125		
Min/Max Fluid Temperature		°F (°C)	120 (49) / 160 (71)		
HYDRONIC HEATING COIL					
Coil Construction			3/8" OD copper tubes, aluminum fins, galvanized steel frame		
Rows...Fins/In			2...16	2...16	3...14
Total Face Area		Sq. Ft.	2.3	2.6	2.8
Approximate Internal Volume		Gallons	0.47	0.53	0.86
1.02					
PIPING CONNECTIONS - (QTY)					
Type			Copper Stubs		
Supply Diameter		Inches	(1) 3/4		
Return Diameter		Inches	(1) 3/4		
RETURN-AIR FILTERS					
Filter Type (Throwaway)		Inches ††	12 X 20 X 1	16 X 20 X 1	20 X 20 X 1
					(2) 12 X 20 X 1
UNIT WEIGHT					
Shipping		lbs	92	109	118
Installed (with water)		lbs	107	127	138
					159

Rinnai is continually updating and improving products. Therefore, specifications are subject to change without prior notice.

† Tested in accordance with ANSI/ASHRAE Standard 37-1988

Side intake filter to be (1) 20"x20"x1" typical for all models.

‡ Airflow shown is for bottom only return-air (blower speed factory set). For air delivery other than stated, refer to Dry Coil Air Delivery table.

Air filter pressure drop for non-standard filters must not exceed 0.08 in. wg.

†† Required filter sizes shown are based on the larger of the ARI (Air Conditioning & Refrigeration Institute) rated cooling airflow or the heating airflow velocity of 300 ft/min for throwaway type or 450 ft/min for high-capacity type.

## Table 4 - Dry Coil Air Delivery (CFM w/ Filter)

UNIT SIZE	OPERATING MODE	BLOWER SPEED	ESP (in. w.c.)								
			0.00	0.10	0.20	0.30	0.40	0.50	0.60	0.70	0.80
<b>37AHA04508KA5 (AH45) (Bottom or Right Side Return w/ Optional Side Filter Rack)</b>			<b>AIRFLOW (CFM)</b>								
	1-1/2 Ton A/C or HP	Low	800	780	760	730	700	670	610	540	470
	2 Ton A/C or HP	Medium	920	900	870	830	780	740	680	610	540
	Hydronic Heat	High	1090	1050	1000	950	900	<b>830 ‡</b>	760	680	590
<b>37AHA04508KA5 (AH45) (Left Side Return w/ Optional Side Filter Rack)</b>			<b>AIRFLOW (CFM)</b>								
	1-1/2 Ton A/C or HP	Low	800	800	790	780	750	730	670	610	550
	2 Ton A/C or HP	Medium	980	970	950	910	860	810	750	680	610
	Hydronic Heat	High	1190	1140	1090	1040	980	920	840	770	690
<b>37AHA06012KA5 (AH60) (Bottom or Right Side Return w/ Optional Side Filter Rack)</b>			<b>AIRFLOW (CFM)</b>								
	1-1/2 Ton A/C or HP	Low	710	710	700	690	680	670	630	590	520
	2 Ton A/C or HP	Medium- Low	860	850	840	830	820	810	790	750	690
	2-1/2 Ton A/C or HP	Medium- High	1150	1140	1130	1110	1050	1020	950	920	820
	Hydronic Heat / 3 Ton A/C or HP	High	1460	1440	1410	1350	1300	<b>1240 ‡</b>	1170	1080	1000
<b>37AHA06012KA5 (AH60) (Left Side Return w/ Optional Side Filter Rack)</b>			<b>AIRFLOW (CFM)</b>								
	1-1/2 Ton A/C or HP	Low	720	720	710	700	690	680	640	600	530
	2 Ton A/C or HP	Medium- Low	870	860	850	840	830	820	800	760	700
	2-1/2 Ton A/C or HP	Medium- High	1210	1200	1180	1160	1100	1070	1000	960	860
	Hydronic Heat / 3 Ton A/C or HP	High	1570	1550	1520	1460	1400	1340	1260	1160	1080
<b>37AHA07514KA5 (AH75) (Bottom or Right Side Return w/ Optional Side Filter Rack)</b>			<b>AIRFLOW (CFM)</b>								
	2-1/2 Ton A/C or HP	Low	1130	1120	1100	1080	1050	1020	990	910	860
	3 Ton A/C or HP	Medium-Low	1340	1320	1300	1270	1240	1200	1160	1130	1030
	Hydronic Heat / 3-1/2 Ton A/C or HP	Medium- High	1570	1550	1510	1480	1440	<b>1400 ‡</b>	1330	1260	1210
	4 Ton A/C or HP	High	1860	1810	1760	1710	1650	1600	1530	1460	1370
<b>37AHA07514KA5 (AH75) (Left Side Return w/ Optional Side Filter Rack)</b>			<b>AIRFLOW (CFM)</b>								
	2-1/2 Ton A/C or HP	Low	1140	1130	1110	1090	1060	1030	1000	920	870
	3 Ton A/C or HP	Medium-Low	1380	1360	1350	1310	1280	1240	1200	1170	1060
	Hydronic Heat / 3-1/2 Ton A/C or HP	Medium- High	1670	1650	1600	1570	1530	1490	1410	1340	1280
	4 Ton A/C or HP	High	2010	1960	1910	1850	1790	1730	1660	1580	1480
<b>37AHA09016KA5 (AH90) (Bottom or Right Side Return w/ Optional Side Filter Rack)</b>			<b>AIRFLOW (CFM)</b>								
	3 Ton A/C or HP	Low	1370	1360	1340	1290	1260	1230	1180	1130	1080
	3-1/2 Ton A/C or HP	Medium-Low	1620	1600	1530	1480	1450	1400	1330	1250	1150
	Hydronic Heat / 4 Ton A/C or HP	Medium-High	1760	1730	1710	1680	1650	<b>1590 ‡</b>	1500	1400	1290
	5 Ton A/C or HP	High	2050	2000	1940	1890	1820	1730	1630	1540	1400
<b>37AHA09016KA5 (AH90) (Left Side Return w/ Optional Side Filter Rack)</b>			<b>AIRFLOW (CFM)</b>								
	3 Ton A/C or HP	Low	1350	1340	1340	1330	1330	1320	1300	1240	1170
	3-1/2 Ton A/C or HP	Medium-Low	1620	1610	1600	1570	1500	1480	1460	1380	1310
	Hydronic Heat / 4 Ton A/C or HP	Medium-High	1800	1790	1780	1770	1720	1660	1600	1510	1400
	5 Ton A/C or HP	High	2180	2140	2070	1990	1920	1850	1760	1680	1570

**LEGEND:**      **CFM** Cubic Feet per Minute  
                   **ESP** External Static Pressure  
                   ‡     Factory Setting

# Accessories

## FIELD SUPPLIED ACCESSORIES

### 1. Humidifier (HUM)

Connect an auxiliary 2.5 FLA, 2.5 LRA @ 115 VAC max Humidifier (if required). Connections are made via the "HUM" quick connects. The humidifier output is on whenever a heating demand is being satisfied. The contacts of this output are isolated to allow field personnel to apply 24 VAC or 115 VAC to one terminal and the humidifier load to the other.

### 2. Electronic Air Cleaner (EAC)

Connect an auxiliary Electronic Air Cleaner (if required); rating shall be max 1.0 Amp @ 115 VAC. This output is energized whenever any of the four blower speeds are energized. Connections are made via 0.250 x 0.032" male quick connect terminals labeled "EAC" and "N3".

### 3. UV Lamp

Connect an auxiliary UV lamp (if required); rating shall be max 1.0 Amp @ 115 VAC. This output is energized whenever any of the four blower speeds are energized. Connections are made via 0.250 x 0.032" male quick connect terminals labeled "UV" and "N2"

### 4. Filter Rack & Bottom Fill Plates

Refer to Figures 3 and 4 in this manual and the table below:

Part	Model	Part Number
Bottom Fill Plate	37HFA045	603000011
Bottom Fill Plate	37HFA060	603000012
Bottom Fill Plate	37HFA075	603000013
Bottom Fill Plate	37HFA090	603000014
Side Filter Rack	37HFA	603000015

### 5. Thermostats

The Standard Model thermostat is an electronic 24 vac, programmable, manual changeover wall-mount thermostat. This thermostat uses two set points to maintain and control room temperature in both the heating and air conditioning modes. The thermostat is designed to maintain +/-2°F accuracy. No batteries are required; temperature, blower, mode, and installer configuration settings are preserved with power off.

Part	Part Number
AC Thermostat	603000018
Heat Pump Thermostat	603000021

### 6. Flow Sensor

Refer to the plumbing section of this manual for installation instructions. The sensor is packaged with the hydronic furnace in the literature bag affixed between the filter and filter retention wire.

Part	Part Number
Sensor, Flow Actuated	603000010

### 7. Anti-scald Thermostatic Temperature Control Valve

Anti-scald thermostatic temperature control valves are an important part of domestic water plumbing because they eliminate the scalding and cold water shocks that can occur in a shower when a toilet is flushed or a faucet is turned on. In an Open Loop system (dual function – space heating and domestic water heating), an anti-scald valve should be installed when the Tankless Water heater set thermostat is above 120°F (49°C); refer to local codes and/or all authority having jurisdiction. For recommended piping configuration refer to Figure 11. Anti-Scald valve shall be thermostatically controlled and meet at least the following specifications:

- Dual certification ASSE 1016-T and ASSE 1017
- IAPMO Approved
- CSA Approved

Constant water temperature under different operating conditions.

An approved anti-scald/anti-chill thermostatic temperature control valve is available through the Rinnai® Accessory Program.

Part	Part Number
Thermostatic Mixing Valve	603000016

## Table 5: Performance Data with V-Series EHS

37AHA045 & 37AHA060 Nominal Heating Capacity (MBH)

UNIT MODEL	EHS PART NUMBER	TRADE NAME	BLOWER SPEED‡	ESP (in. W.C.)	AIR DELIVERY	ENTERING WATER TEMPERATURE (°F)				
						120	130	140	150†	160
37AHA04508KA5 (AH45)	REU-V1616WC	C42e	HIGH	0.5	800	34.2	38.0	45.8	51.1	57.0
	REU-V2020WC	C53e				35.3	38.2	46.4	50.7	57.5
	REU-V2532WC	C85e				31.0	37.0	45.3	50.0	52.6
	REU-V2532WCD	C85e PLUS				31.0	37.0	45.3	50.0	52.6
	REU-V2520FFUC	C53i				34.6	40.6	46.2	52.3	58.3
	REU-V2520FFUCD	C53i PLUS				34.6	40.6	46.2	52.3	58.3
	REU-V2532FFUC	C85i				34.9	40.2	45.1	51.1	56.8
	REU-V2532FFUCD	C85i PLUS				34.9	40.2	45.1	51.1	56.8
	REU-V3237WC	C98e				34.4	39.3	45.2	51.0	55.6
	REU-V3237FFUC	C98i				34.6	39.9	45.6	52.1	58.0
37AHA06012KA5 (AH60)	REU-V1616WC	C42e	HIGH	0.5	1200	39.1	46.4	53.8	61.5	69.5
	REU-V2020WC	C53e				38.9	46.2	53.6	61.1	68.2
	REU-V2532WC	C85e				39.7	46.0	52.7	60.5	68.9
	REU-V2532WCD	C85e PLUS				39.7	46.0	52.7	60.5	68.9
	REU-V2520FFUC	C53i				37.5	45.0	52.5	60.0	68.0
	REU-V2520FFUCD	C53i PLUS				37.5	45.0	52.5	60.0	68.0
	REU-V2532FFUC	C85i				41.2	48.3	55.8	62.2	69.0
	REU-V2532FFUCD	C85i PLUS				41.2	48.3	55.8	62.2	69.0
	REU-V3237WC	C98e				37.6	45.4	54.4	61.5	70.5
	REU-V3237FFUC	C98i				38.7	46.6	54.4	61.9	69.8

### Legend

**CFM** Cubic Feet Per Minute  
**ESP** External Static Pressure  
**EHS** External Heat Source (Rinnai® V-Series Water Heaters)  
**‡** Factory Setting  
**†** Recommended Operating Point

### Notes

- (1) 1 MBH = 1000 Btuh
- (2) Air entering at 68°F
- (3) Capacities are based on a piping arrangement with a total equivalent length of 100 ft.



## Table 6: Performance Data with V-Series EHS

Unit Sizes: 37AHA075 & 37AHA090 Nominal Heating Capacity (MBH)

UNIT MODEL	EHS PART NUMBER	TRADE NAME	BLOWER SPEED‡	ESP (in. W.C.)	AIR DELIVERY	ENTERING WATER TEMPERATURE (°F)				
						120	130	140	150†	160
37AHA07514KA5 (AH75)	REU-V1616WC	C42e	MEDIUM-HIGH	0.5	1400	46.9	55.8	65.1	74.6	83.5
	REU-V2020WC	C53e				46.4	55.2	64.4	73.6	83.0
	REU-V2532WC	C85e				50.2	59.3	68.6	78.2	87.4
	REU-V2532WCD	C85e PLUS				50.2	59.3	68.6	78.2	87.4
	REU-V2520FFUC	C53i				49.6	59.3	68.5	78.3	88.4
	REU-V2520FFUCD	C53i PLUS				49.6	59.3	68.5	78.3	88.4
	REU-V2532FFUC	C85i				48.6	57.2	66.3	75.9	85.1
	REU-V2532FFUCD	C85i PLUS				48.6	57.2	66.3	75.9	85.1
	REU-V3237WC	C98e				47.4	56.6	66.0	74.9	83.9
	REU-V3237FFUC	C98i				48.2	57.4	67.2	75.6	85.4
37AHA09016KA5 (AH90)	REU-V1616WC	C42e	MEDIUM-HIGH	0.5	1600	53.8	63.9	74.0	84.3	86.9
	REU-V2020WC	C53e				53.4	62.6	72.4	81.7	94.5
	REU-V2532WC	C85e				55.0	64.0	74.4	85.2	95.7
	REU-V2532WCD	C85e PLUS				55.0	64.0	74.4	85.2	95.7
	REU-V2520FFUC	C53i				57.3	68.3	78.4	89.3	101.1
	REU-V2520FFUCD	C53i PLUS				57.3	68.3	78.4	89.3	101.1
	REU-V2532FFUC	C85i				55.0	64.0	74.4	85.2	95.7
	REU-V2532FFUCD	C85i PLUS				55.0	64.0	74.4	85.2	95.7
	REU-V3237WC	C98e				51.8	62.5	74.5	85.1	95.5
	REU-V3237FFUC	C98i				52.9	63.9	65.8	86.6	97.7

### Legend

**CFM** Cubic Feet Per Minute  
**ESP** External Static Pressure  
**EHS** External Heat Source (Rinnai® V-Series Water Heaters)  
**‡** Factory Setting  
**†** Recommended Operating Point

### Notes

- (1) 1 MBH = 1000 Btuh
- (2) Air entering at 68°F
- (3) Capacities are based on a piping arrangement with a total equivalent length of 100 ft.

## Table 7: Performance Data with LS-Series EHS

Unit Sizes: 37AHA045 through 090 Nominal Heating Capacity (MBH)

UNIT MODEL	EHS PART NUMBER	TRADE NAME	BLOWER SPEED‡	ESP (in. W.C.)	AIR DELIVERY (CFM)‡	ENTERING WATER TEMPERATURE (°F)				
						120	130	140	150†	160
37AHA04508KA5 (AH45)	REU-VA2528WD	R75LSe	HIGH	0.5	800	33.1	39.2	45.3	51.4	58.2
	REU-VA2528FFUD	R75LSi				32.6	38.4	44.5	50.6	56.2
	REU-VA2535WD	R94LSe				32.2	37.8	43.7	49.6	56.0
	REU-VA2535FFUD	R94LSi				31.6	39.7	45.2	51.7	57.7
37AHA06012KA5 (AH60)	REU-VA2528WD	R75LSe	HIGH	0.5	1200	38.9	46.0	53.5	63.2	68.5
	REU-VA2528FFUD	R75LSi				39.5	46.7	53.3	62.9	69.9
	REU-VA2535WD	R94LSe				38.3	47.1	54.1	60.1	68.5
	REU-VA2535FFUD	R94LSi				38.8	45.2	52.1	59.1	66.9
37AHA07514KA5 (AH75)	REU-VA2528WD	R75LSe	MEDIUM-HIGH	0.5	1400	50.1	58.5	68.4	77.4	85.3
	REU-VA2528FFUD	R75LSi				50.7	59.8	68.1	77.9	87.0
	REU-VA2535WD	R94LSe				50.3	58.1	68.0	77.0	87.0
	REU-VA2535FFUD	R94LSi				50.3	58.1	68.0	77.0	87.0
37AHA09016KA5 (AH90)	REU-VA2528WD	R75LSe	MEDIUM-HIGH	0.5	1600	55.3	66.3	76.4	88.0	99.5
	REU-VA2528FFUD	R75LSi				54.4	63.9	74.9	85.9	96.5
	REU-VA2535WD	R94LSe				53.6	63.4	73.8	85.0	96.4
	REU-VA2535FFUD	R94LSi				56.7	65.9	76.5	87.4	98.4

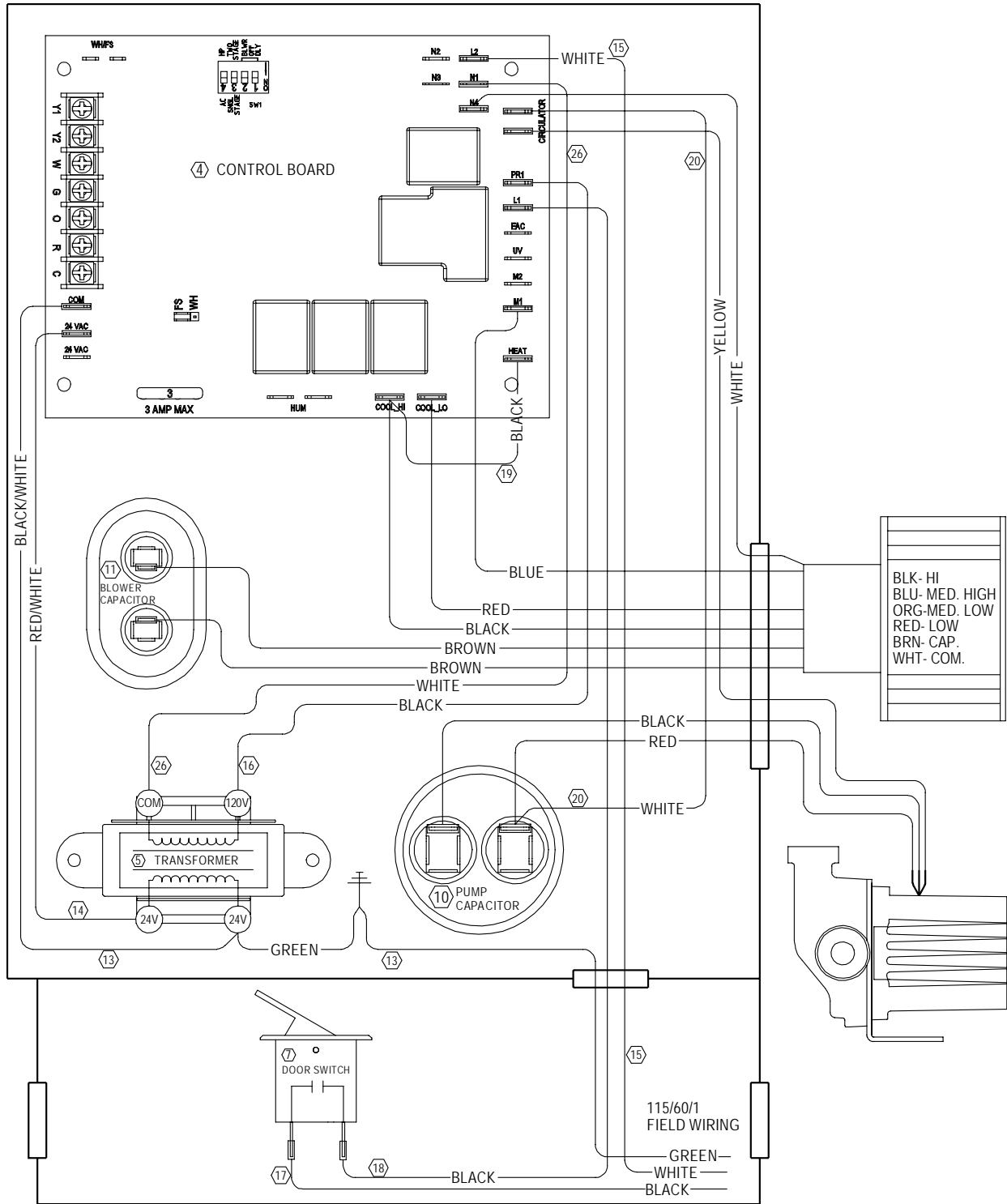
### Legend

<b>CFM</b>	Cubic Feet Per Minute
<b>ESP</b>	External Static Pressure
<b>EHS</b>	External Heat Source (Rinnai® V-Series Tankless Water) Heaters
‡	Factory Setting
†	Recommended Operating Point

### Notes

- (1) 1 MBH = 1000 Btuh
- (2) For LS-Series only: to attain water temperatures settings of 150° F and 160° F use optional controller MCC-91-1US.
- (3) Air entering at 68°F
- (2) Capacities are based on a piping arrangement with a total equivalent length of 100 ft.

# 37AHA045 Wiring Diagram



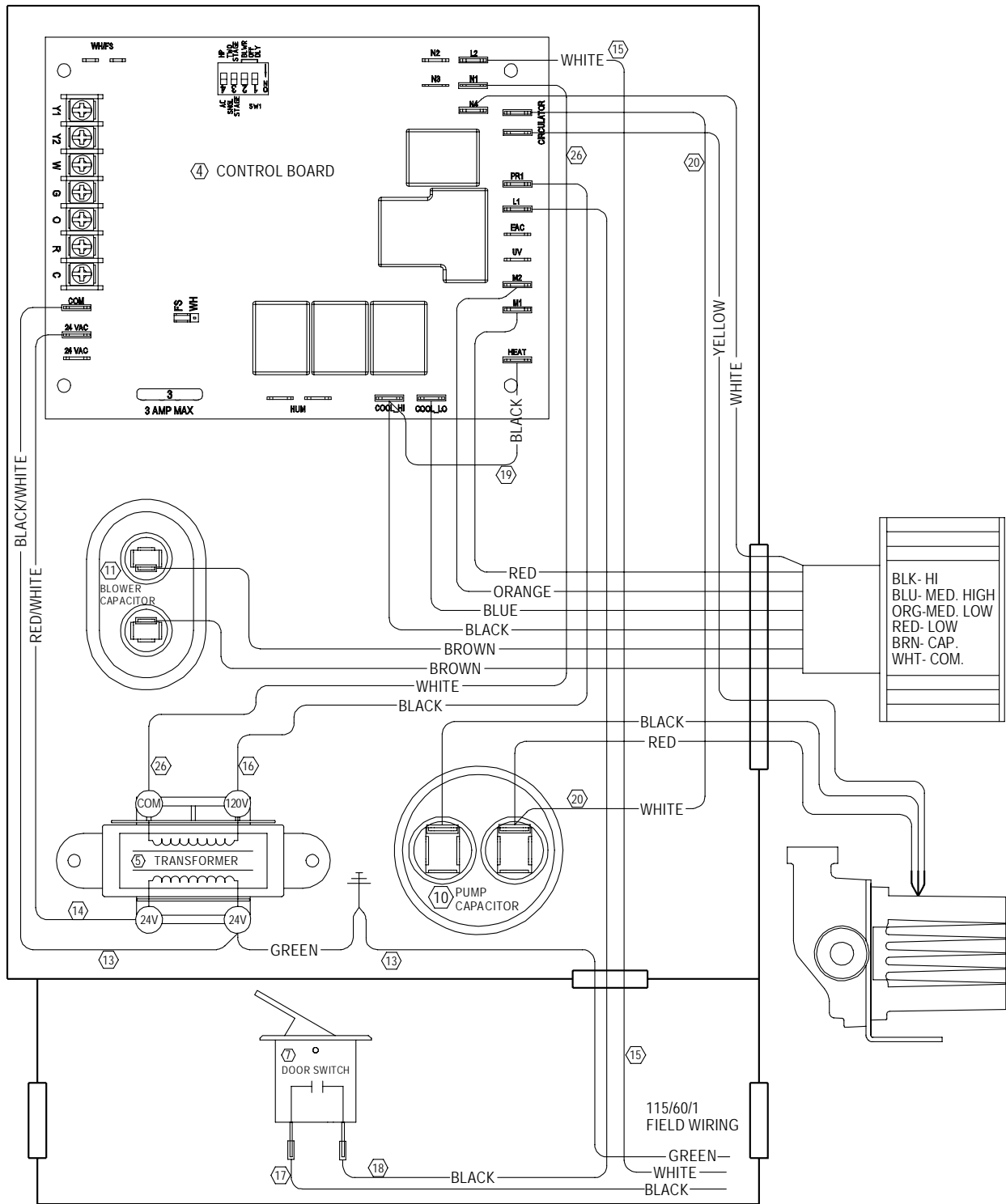
**⚠ DANGER**  
ELECTRICAL SHOCK HAZARD  
DISCONNECT POWER BEFORE  
SERVICING.

**⚠ WARNING**  
USE COPPER CONDUCTORS  
ONLY SUITABLE FOR AT LEAST  
75° C.

**99** Wire Identification numbers  
for manufacturing use.

**Figure 25**

# 37AHA060 Wiring Diagram



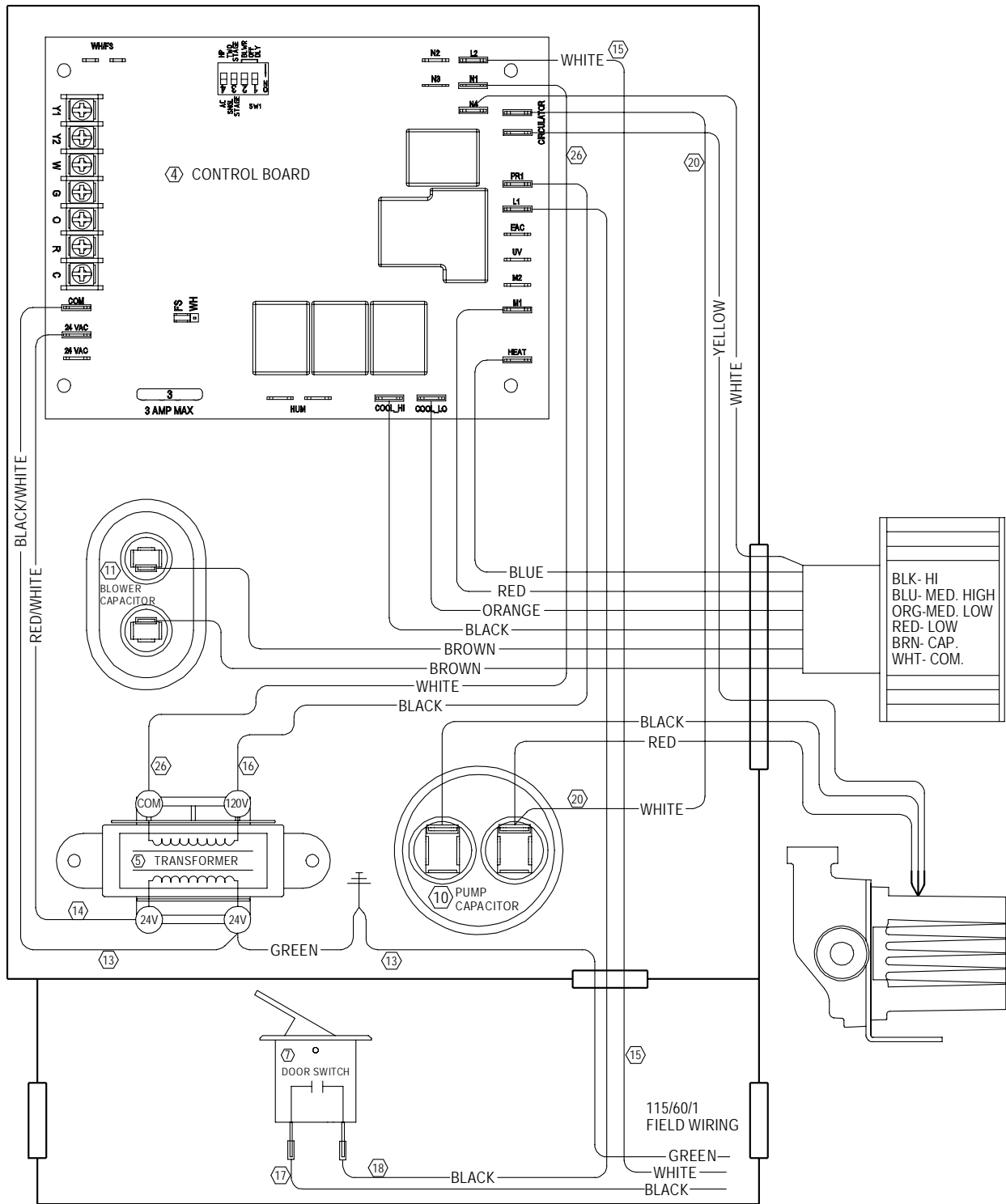
**⚠ DANGER**  
ELECTRICAL SHOCK HAZARD  
DISCONNECT POWER BEFORE  
SERVICING.

**⚠ WARNING**  
USE COPPER CONDUCTORS  
ONLY SUITABLE FOR AT LEAST  
75° C.

**99** Wire Identification numbers  
for manufacturing use.

**Figure 26**

# 37AHA075 and 37AHA090 Wiring Diagram



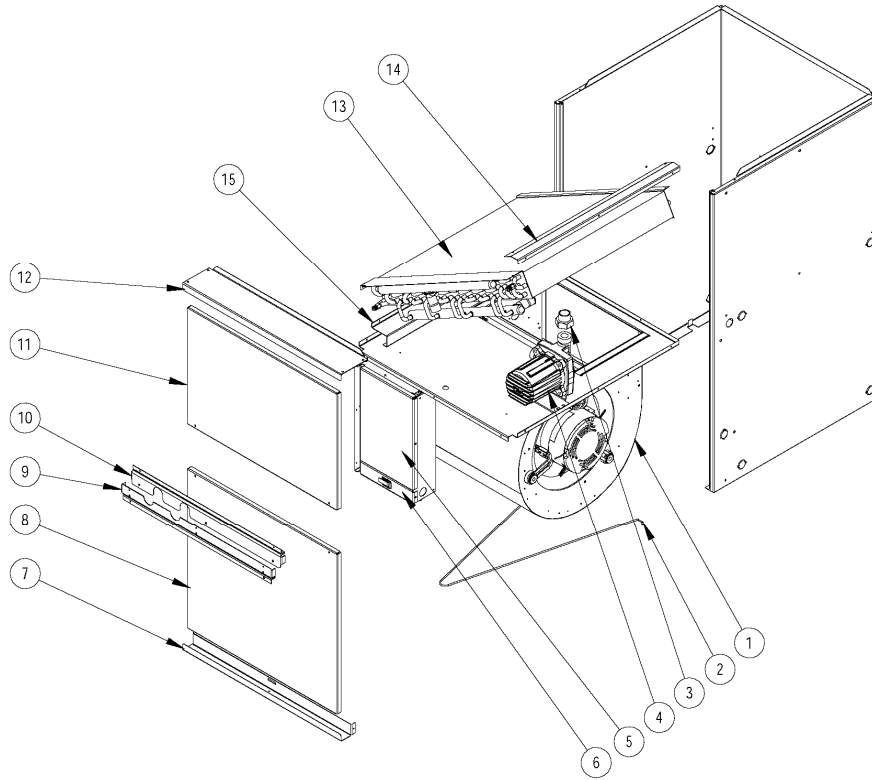
**⚠ DANGER**  
ELECTRICAL SHOCK HAZARD  
DISCONNECT POWER BEFORE  
SERVICING.

**⚠ WARNING**  
USE COPPER CONDUCTORS  
ONLY SUITABLE FOR AT LEAST  
75° C.

**99** Wire Identification numbers  
for manufacturing use.

**Figure 27**

# Parts List

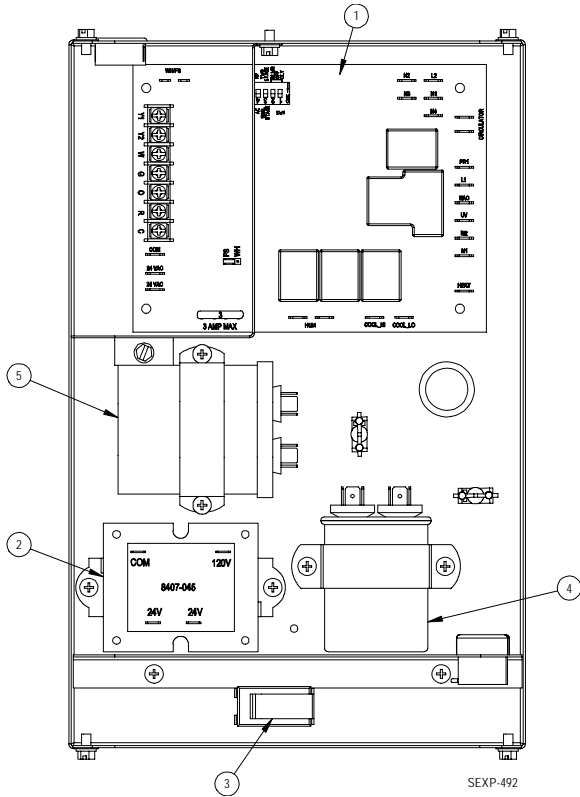


**Figure 28: Unit Assembly**

UNIT ASSEMBLY						
Balloon Number	Part Number	Description	MODEL			
			37AHA 045	37AHA 060	37AHA 075	37AHA 090
1	608000010	Complete Blower Assembly-See blower assembly section for	X			
	608000011			X		
	608000012				X	
	608000013					X
2	609000018	Filter Retention Wire	X	X	X	2
3	607000011	3/4" Pump	2	2	2	2
4	607000010	Hydronic Pump	X	X	X	X
5	609000019	Control Panel Front Cover	X	X	X	X
6	609000052	High Voltage Compartment	X	X	X	X
	609000020		X			
7	609000021	Lower Front Fill		X		
	609000022				X	
	609000023					X
	609000024		X			
8	609000025	Lower Front Service Door		X		
	609000026				X	
	609000027					X
	609000027					X

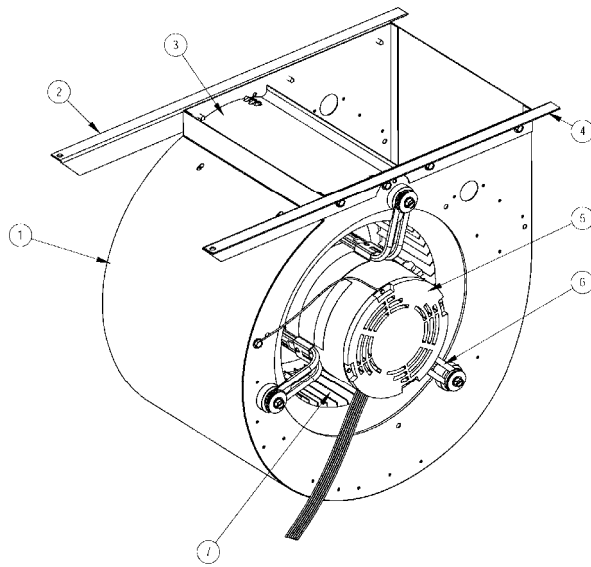
UNIT ASSEMBLY						
Balloon Number	Part Number	Description	MODEL			
			37AHA 045	37AHA 060	37AHA 075	37AHA 090
9	609000028	Lower Front Fill Panel	X			
	609000029			X		
	609000030				X	
	609000031					X
10	609000032	Upper Front Fill Panel	X			
	609000033			X		
	609000034				X	
	609000035					X
11	609000036	Upper Front Service Door	X			
	609000037			X		
	609000038				X	
	609000039					X
12	609000040	Top Fill	X			
	609000041			X		
	609000042				X	
	609000043					X
13	607000012	Water Coil	X			
	607000013			X		
	607000014				X	
	607000015					X
14	609000044	Coil Attachment Bracket	X			
	609000045			X		
	609000046				X	
	609000047					X
15	609000048	Coil Support			X	

# Parts List



CONTROL PANEL					
Balloon Number	Part Number	Description	605000011 (sizes 045, 060)	605000012 (size 075)	605000013 (size 090)
1	605000010	Control Board	X	X	X
2	605000015	Transformer	X	X	X
3	605000014	Door Switch	X	X	X
4	605000018	Pump Capacitor	X	X	X
5	605000016	Blower Capacitor	X		X
	605000017	Blower Capacitor		X	

**Figure 29:** Control Panel



BLOWER ASSEMBLY						
Balloon Number	Part Number	Description	BLOWER			
			608000010 (size 045)	608000011 (size 060)	608000012 (size 075)	608000013 (size 090)
1	609000053	Blower Housing	X			
	609000054			X		
	609000055				X	
	609000056					X
2	609000057	Left Blower Angle	X	X	X	X
3	608000017	Diffuser	X			
	608000018			X		
	608000019				X	
	608000020					X
4	609000058	Right Blower Angle	X	X	X	X
5	605000019	1/3 HP Motor	X			
	605000020	1/2 HP Motor		X		
	605000021	3/4 HP Motor			X	
	605000022	1 HP Motor				X
6	609000059	Motor Mount Kit	X	X	X	X
7	608000021	Blower Wheel	X			
	608000022			X		
	608000023				X	
	608000024					X

**Figure 30:** Blower Assembly

## Limited Warranty

### Warranty Information

The installer is responsible for the correct installation of your Hydronic Furnace.

Please complete the information below to keep for your records:

Purchased from: \_\_\_\_\_

Address: \_\_\_\_\_ Phone: \_\_\_\_\_

\_\_\_\_\_

Date of Purchase: \_\_\_\_\_

Model No.: \_\_\_\_\_

Serial No.: \_\_\_\_\_

Installed by: \_\_\_\_\_ Installer's License No.: \_\_\_\_\_

Address: \_\_\_\_\_ Phone: \_\_\_\_\_

Date of Installation: \_\_\_\_\_

To register your hydronic furnace or tankless water heater, please visit [www.rinnairegistration.com](http://www.rinnairegistration.com). For those without internet access, please call 1-866-RINNAI1 (745-6241).

### Limited Warranty

#### What is covered?

This Warranty covers any defects in materials or workmanship when the product is installed and operated according to Rinnai written installation instructions, subject to the terms within this Limited Warranty document. Rinnai's hydronic furnace should be installed by a state qualified or licensed contractor. Improper installation may void this Warranty. This Warranty extends to the original purchaser, but only while the product remains at the site of the original installation. This Warranty only extends through the first installation of the product and terminates if the product is moved or reinstalled at a new location.

#### How long does coverage last?

Item	Period of Coverage (from date of purchase)
Parts	5 Years *
Reasonable Labor	1 Year *

\* In order to receive full warranty coverage on the furnace when connected to any other type or brand of product other than a Rinnai tankless water heater, the flow rate through the furnace must not exceed a maximum of 5 GPM.



## Limited Warranty

### What will Rinnai do?

Rinnai will repair or replace the covered product or any part or component that is defective in materials or workmanship as set forth. Labor will only be covered when the furnace is connected to a Rinnai tankless water heater. Labor is not covered if connected to any other type or brand of unit. Rinnai will pay reasonable labor charges associated with the repair or replacement of any such part or component. All repair parts must be genuine Rinnai parts. All repairs or replacements must be performed by an individual or servicing company that is properly trained, state qualified or licensed to do the type of repair. Replacement of the product may be authorized by Rinnai only. Rinnai does not authorize any person or company to assume for it any obligation or liability in connection with the replacement of the product. If Rinnai determines that repair of a product is not possible, Rinnai will replace the product with a comparable product at Rinnai's discretion. If a component or product returned to Rinnai is found to be free of defects in material or workmanship, or damaged by improper installation or damaged during return shipping, the warranty claim for product, parts and labor may be denied.

### How do I get service?

You must contact a state qualified/licensed contractor or authorized service provider for the repair of a product under this Warranty. For the name of a qualified/authorized service provider please contact your place of purchase, visit the Rinnai website ([www.rinnai.us](http://www.rinnai.us)), call Rinnai at 1-800-621-9419 or write to Rinnai at 103 International Drive, Peachtree City, Georgia 30269.

Proof of purchase is required to obtain warranty service. You may show proof of purchase with a dated sales receipt, or by registering within 30 days of purchasing the product. To register your hydronic furnace or tankless water heater, please visit [www.rinnaregistration.com](http://www.rinnaregistration.com). For those without internet access, please call 1-866-RINNAI1 (745-6241). Receipt of Registration by Rinnai will constitute proof-of-purchase for this product. However, Registration is not necessary in order to validate this Warranty.

### What is not covered?

This Warranty does not cover any failures or operating difficulties due to the following:

- accident, abuse, or misuse
- alteration
- misapplication
- force majeure
- improper installation (such as but not limited to inadequate water quality, condensate damage, or absence of a drain pan under the appliance)
- improper maintenance (such as but not limited to scale build-up, or freeze damage)
- incorrect sizing
- any other causes other than defects in materials or workmanship

This Warranty does not apply to any product whose serial number or manufacture date has been defaced. This Warranty does not cover any product used in an application that uses chemically treated water.

### Limitation on warranties

No one is authorized to make any other warranties on behalf of Rinnai America Corporation. Except as expressly provided herein, there are no other warranties, expressed or implied, including, but not limited to warranties of merchantability or fitness for a particular purpose, which extend beyond the description of the warranty herein and further Rinnai shall not be liable for indirect, incidental, special, consequential or other similar damages that may arise, including lost profits, damage to person or property, loss of use, inconvenience, or liability arising from improper installation, service or use. Some states do not allow the exclusion or limitation of incidental or consequential damages, so the above limitation may not apply to you.

Any implied warranties of merchantability and fitness arising under state law are limited in duration to the period of coverage provided by this limited Warranty, unless the period provided by state law is less. Some states do not allow limitations on how long an implied Warranty lasts, so the above limitation may not apply to you.

This Warranty gives you specific legal rights, and you may also have other rights which vary from state to state.





# Ask about **Rinnai**

## Rinnai's other fine products

Rinnai America Corporation  
103 International Drive  
Peachtree City, GA 30269  
TOLL FREE: 1-800-621-9419  
[www.rinnai.us](http://www.rinnai.us)



### Tankless Water Heaters

- Residential and Commercial Applications
- Continuous Hot Water
- Up to 9.8 GPM
- High Energy Efficiency
- Propane or Natural Gas
- Internal or External Installation
- Digital Temperature Control
- Small, Compact Design



### Direct Vent Furnaces

- High Efficiency
- Cool-to-the-touch Cabinet
- Blower Included
- Vent Terminal A Included
- 556 and 1004 Models Available in Beige, White and Silver
- Gas Conversion Kit Included



### Direct-Vent Fireplace, RHFE-750ETR

- Up to 83% AFUE Energy Efficiency
- Zero-Clearance Installation
- Available in Four Options of Fronts
- Remotes and Fan Included
- Gas Conversion Kit Available



### Hydronic Furnace

- Designed for Use with Rinnai Systems
- Domestic Hot Water Priority
- Optional Programmable Thermostat
- Zero Clearance to Combustibles
- Accommodates Standard Cased-Coils

To register your hydronic furnace or tankless water heater, please visit [www.rinnairegistration.com](http://www.rinnairegistration.com). For those without internet access, please call 1-866-RINNAI1 (745-6241).