

Owner's Operation and Installation Manual for the



ES17 (RHFE-433RFA) ES22 (RHFE-558RFA)



Energysaver®

Gas Direct Vent Wall Furnace

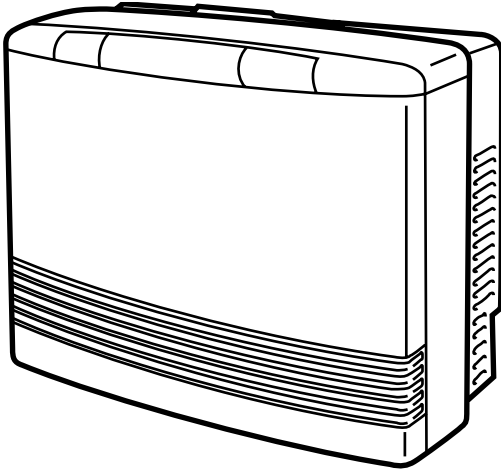

Table of Contents	2
Safety Information	3
Operating Instructions	8
Care and Maintenance ...	10
Fault Codes	12
Installation Instructions...	14
Parts List	32
Consumer Support	41

Register your product at www.rinnairregistration.com or call 1-866-RINNAI1 (746-6241)

WARNING: If the information in these instructions is not followed exactly, a fire or explosion may result causing property damage, personal injury or loss of life.

- Do not store or use gasoline or other flammable vapors and liquids in the vicinity of this or any other appliance.
- **WHAT TO DO IF YOU SMELL GAS**
 - Do not try to light any appliance.
 - Do not touch any electrical switch; do not use any phone in your building.
 - Immediately call your gas supplier from a neighbor's phone. Follow the gas supplier's instructions.
 - If you cannot reach your gas supplier, call the fire department.
- Installation and service must be performed by a qualified installer, service agency or the gas supplier.

Rinnai®

INSTALLER: Leave this manual with the appliance.
CONSUMER: Retain this manual for future reference.

This appliance may be installed as an OEM installation in a manufactured home (USA only) or mobile home and must be installed in accordance with the manufacturer's instructions and the *Manufactured Home construction and Safety Standard, Title 24 CFR, Part 3280*, in the United States, or the *Mobile Home Standard, CAN/CSA Z240 MH Series*, in Canada. This appliance is only for use with types of gas indicated on the rating plate. A conversion kit is supplied with the appliance.

This appliance may be installed in an aftermarket, permanently located, manufactured home (USA only) or mobile home, where not prohibited by local codes.

This appliance is only for use with the type of gas indicated on the rating plate. This appliance is not convertible for use with other gases, unless a certified kit is used.

Table of Contents

Consumer Safety Information

<i>Safety Definitions</i>	3
<i>Safety Behaviors and Practices</i>	3
<i>Safety Features</i>	4

Specifications

<i>Appliance Specifications</i>	4, 5
<i>Features</i>	5

Operating Instructions

<i>Getting to Know your New Heating Appliance</i>	6
<i>Control Panel</i>	7
<i>Operating the Heater Manually</i>	8, 9
<i>Care and Maintenance</i>	10
<i>Before Making a Service Call</i>	11
<i>Fault Codes</i>	12
<i>Restart Function</i>	13
<i>Troubleshooting</i>	13

Installation Instructions

<i>General Instructions</i>	14
<i>Gas Connection</i>	15
<i>Clearances to Combustibles</i>	15
<i>Flue Terminal Clearances</i>	16-18
<i>Dimensions</i>	18
<i>Installation Parts</i>	19
<i>Drilling Flue Hole</i>	20
<i>Flue Manifold Installation</i>	21, 22
<i>Extension Kit Installation</i>	23-25
<i>Connecting the Appliance</i>	26
<i>Operating Instructions</i>	27
<i>Cut-Away Diagram</i>	28
<i>Wiring Diagram</i>	29
<i>Ladder Diagram</i>	30
<i>Flow Diagram</i>	31
<i>Parts List</i>	32-40

Consumer Support

<i>Warranty Information</i>	41
<i>Limited Warranty</i>	41, 42

Consumer Safety Information

Safety Definitions



This is the safety alert symbol. This symbol alerts you to potential hazards that can kill or hurt you and others.



Indicates an imminently hazardous situation which, if not avoided, will result in death or serious injury.



Indicates a potentially hazardous situation which, if not avoided, could result in death or serious injury.



Indicates a potentially hazardous situation which, if not avoided, could result in minor or moderate injury. It may also be used to alert against unsafe practices.

Safety Behaviors and Practices



- Keep the area around the appliance clear and free from combustible materials, gasoline, and other flammable vapors and liquids.
- Never store liquid propane containers indoors.
- Do not use this appliance if any part has been under water. Immediately call a qualified service technician to inspect the appliance and to replace any part of the control system and any gas control which has been under water.
- This appliance is equipped with a three-prong plug for your protection against shock hazard and should be plugged directly into a properly grounded three-prong receptacle. Do not cut or remove the ground prong from this plug.
- Any alteration to the appliance or its controls can be dangerous.
- Do not operate appliance with the panels removed, cracked or broken. Replacement of the panels should be done by a licensed or qualified service person.



- Do not block the warm air discharge. Do not allow anyone to sleep directly in front of the appliance.
- Due to high temperatures, the appliance should be located out of traffic and away from furniture and draperies.
- Children and adults should be alerted to the hazards of high surface temperature and should stay away to avoid burns or clothing ignition.
- Young children should be carefully supervised when they are in the same room as the appliance.
- Clothing or other flammable material should not be placed on or near the appliance.
- Any safety screen or guard removed for servicing must be replaced prior to operating the appliance.
- Do not insert items into the louvers.
- Do not spray aerosols near the appliance while it is operating. Most aerosols contain butane gas which is flammable.
- Do not unplug the appliance while it is operating or while the fans are on.
- Do not use bare hands to touch the front louvers due to high temperatures which may cause burns.
- Wear hand protection when touching the side back covers, front louver, and rear intake for the convection fan.

Safety Features

- **Overheat:** The appliance will automatically shut down when the appliance exceeds a predetermined temperature.
- **Flame Failure:** The appliance will automatically shut down if the burner flame is extinguished.
- **Power Failure:** The appliance will cut off the gas if it loses electrical power.
- **Power Surge Fuse:** A glass fuse on the PC board protects against overcurrent. If the fuse blows then all indicator lamps will be off.
- **Spark Detector:** The appliance automatically shuts down if there is an abnormal spark at ignition.
- **Fusible Link:** In case the overheat feature prevents the temperature from rising then the fusible link will break shutting off the appliance.

Specifications

Appliance Specifications

Application	For manufactured home (USA only) or mobile home or residential installation convertible for use with natural gas and liquefied petroleum gases (propane / LPG) when provision is made for the simple conversion from one gas to the other. For commercial setting. For installation at altitudes up to 10,200 feet (3109 m).
General Description	Forced combustion, forced convection, flued gas furnace
Operation	Push button electronic
Gas Connection	1/2 in NPT
Gas Control	Electronic
Burners	Stainless steel Bunsen burner
Temperature Control	Electronic thermostat
Ignition System	Electronic spark ignition
Flue System	The flue must be terminated to atmosphere with only flue components listed with the appliance's certification. Warranty will be voided if non listed components are installed.
Humidifier Tray	Capacity - 3 pints (1300 cc)
Electrical Connection	AC 120V; 60 Hz; ES17: 45 watts; ES22: 50 watts
Weight	53 lbs (24 kg)
Noise Level	ES17: 32-42 dB; ES22: 32-39 dB
AFUE Rating	Natural Gas: 81% Propane: 80%

Rinnai is continually updating and improving products. Therefore, specifications are subject to change without prior notice.

The efficiency rating of this appliance is a product thermal efficiency rating determined under continuous operating conditions and was determined independently of any installed system.

Appliance Specifications

	Natural Gas	Propane Gas
Minimum supply gas pressure	3.5 in (89 mm) W.C.	8.0 in (203 mm) W.C.
Maximum supply gas pressure	10.5 in (267 mm) W.C.	13.0 in (330 mm) W.C.

ES17		
	Natural Gas	Propane Gas
BTU/hour input	Low 8200 High 16700	Low 8200 High 16700
BTU/hour output	Low 6560 High 13400	Low 6560 High 13400

ES22		
	Natural Gas	Propane Gas
BTU/hour input	Low 8200 High 21500	Low 8200 High 20700
BTU/hour output	Low 6560 High 17200	Low 6560 High 16560

Features

- Restarts automatically when ignition or combustion fails.
- Clean Heating Forced Flue Type
- Easy Operation One-Touch Ignition
- Sensible Temperature Control Feature
- Comfortable Room Temperature Control and Display
- Warm Air Outlet at Floor Level (keeps your feet warm)
- Function Lock
- Room Temperature Setting Memory
- Clean the Air Filter - Indicator Lamp
- Energy Saving Economy Setting
- Humidifier Tray
- Air Flow Directional Louvers
- Direct Vent Easily Installed
- Proportional Heating Variable Capacity
- Hush! Quiet Operation
- Modern Design Minimizes Floor Space Requirements
- Fault Code Message Display

Operating Instructions

Getting to know your new heating appliance

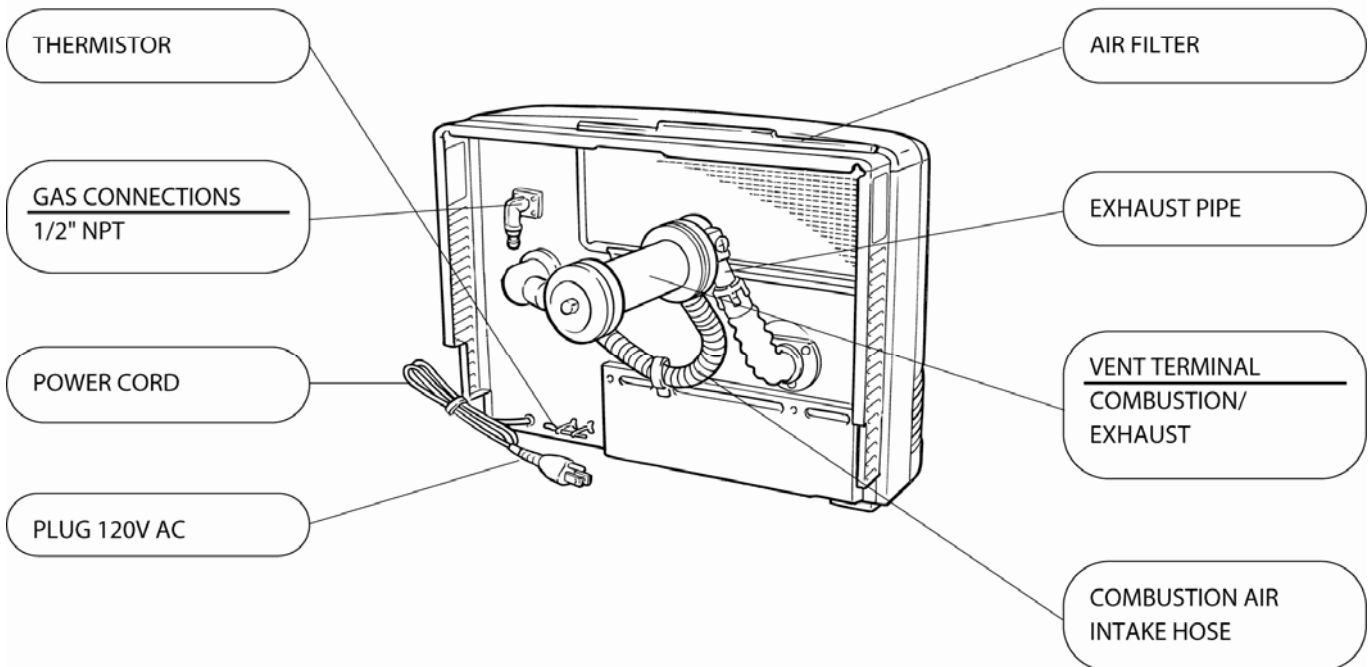
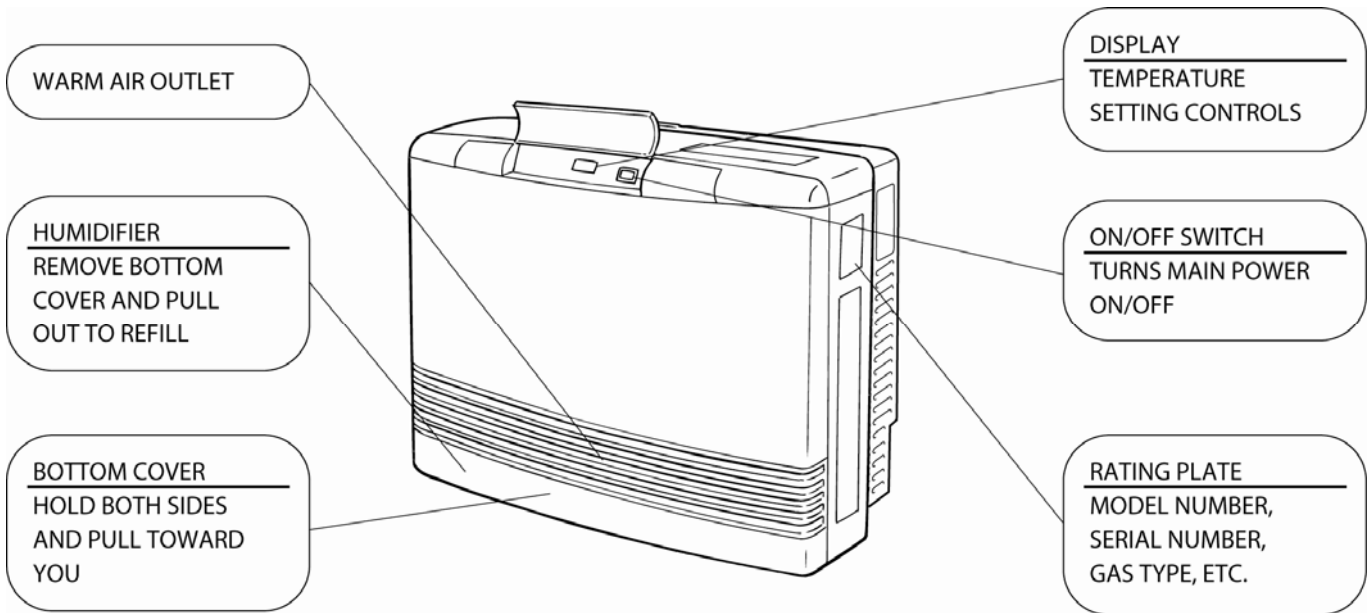

Control Panel

All buttons beep when operated.

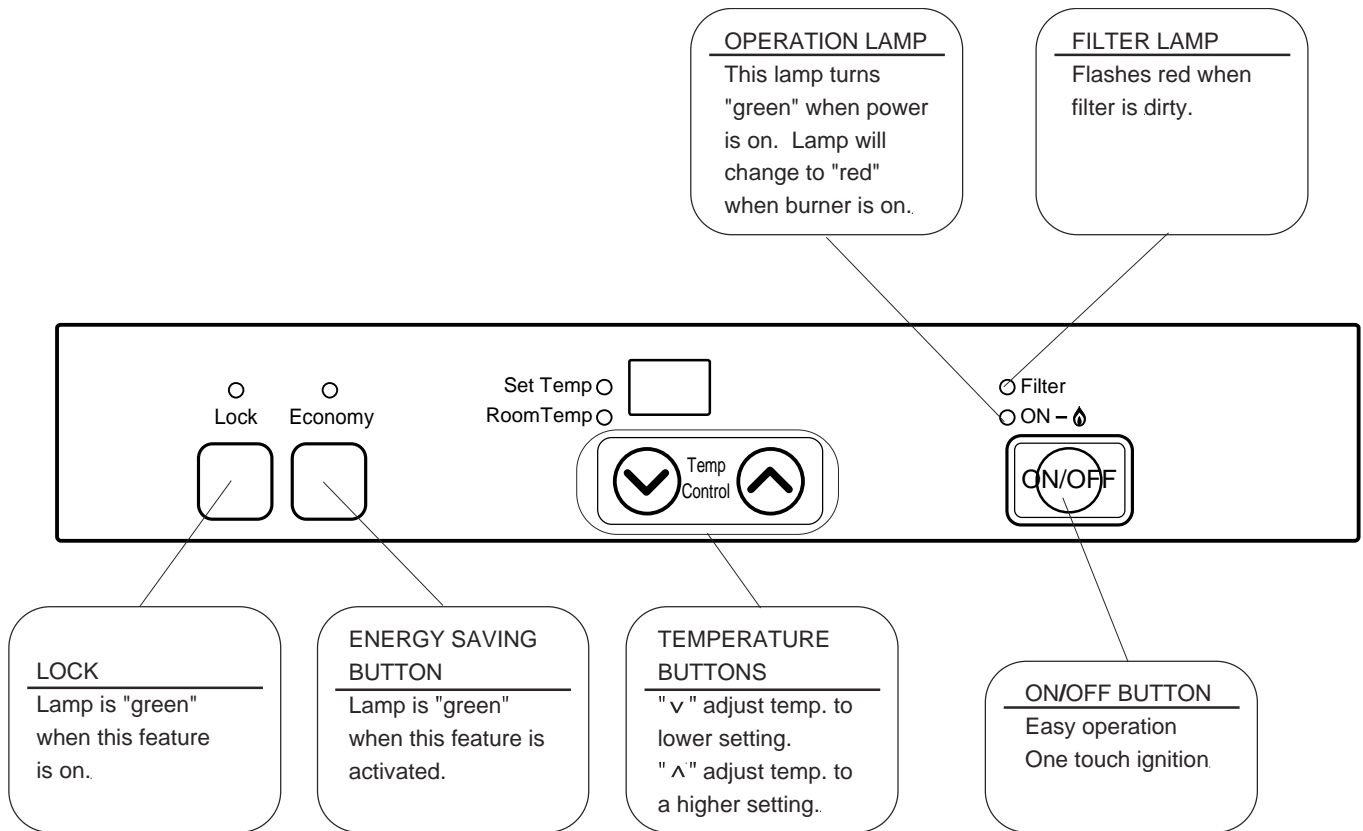

Turning the heater ON

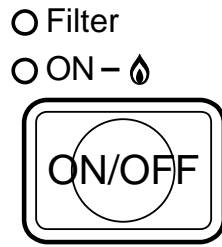

When you press and release the ON/OFF button, the Temperature Level lamps will illuminate, the combustion fan will begin to run, and the spark will ignite the main burner.

This heater has an automatic ignition system. When the main burner has lit, the combustion lamp will glow red, and the spark will stop.

If ignition does not occur after 15 seconds, the appliance will automatically turn off and the Temperature Level lamps will flash indicating a fault code. This may occur when using the appliance for the first time or if it has not been used for a while. Try operating the appliance again.

There may be a smell of burning dust or oil the first time the heater is lit or when the heater has been out of operation for a long time.

The appliance may make noises after ignition or when it is turned off. This is normal and is due to the thermal expansion or contraction of its components.

Turning the heater OFF

Press the ON/OFF button. Do not turn off by unplugging at the power outlet.



The fan will continue to run for a short time to prevent the internal components from overheating.

Adjusting the Temperature

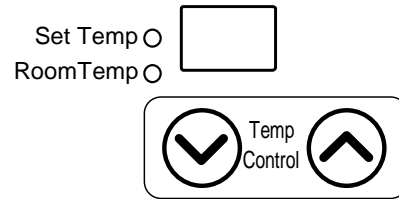

The temperature setting and the room temperature are indicated by the L.E.D. display on the control panel. When the appliance is turned on the temperature setting will be displayed for 10 seconds. The display will then show the room temperature. The default temperature setting is 72° F.

To change the temperature setting press one of the temperature control buttons once. The "Set Temp" should light up and the display will show the current temperature setting. Continue to press the control buttons until the desired temperature setting is reached. After 10 seconds the display will return to showing the room temperature.

The thermostat automatically modulates the burner and the fan to maintain the temperature setting.

The temperature settings available are:

- LO - burner is on minimum combustion
- 60° F - 80° F in two degree increments
- HI - burner is on maximum combustion

Economy Mode

Pressing the Economy button will cause the appliance to go into Economy Mode and the green lamp will glow. This results in the temperature setting being reduced by 2° F, 30 minutes after the room temperature has reached the temperature setting. After another 30 minutes the temperature setting is reduced another 2° F. This could result in the temperature setting being reduced by a maximum of 4° F. The intent of this mode is to save energy.

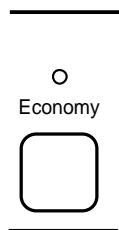

When the heater is running at the LO setting, the Economy Mode does not function.

Operating the Heater Manually

Lock

This feature locks the buttons to prevent unintended operation.

Press the Lock button to activate and the lamp will glow. Pressing and holding the Lock button for two seconds will disengage the Lock.

If the Lock is engaged while the unit is operating, all buttons will be disabled except for the ON/OFF button.

If the Lock is engaged while the unit is off, then all buttons will be disabled. The Lock must be disengaged in order to turn the unit on.

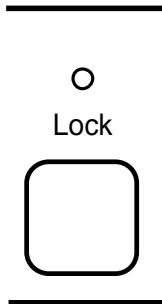

Adding Water to the Humidifier

CAUTION Do not remove the bottom trim panel or the humidifier tray while warm air is flowing.

Warm air is humidified when it passes over the water in the tray.

To fill the tray, remove the bottom trim panel below the louvers by pulling on both sides. Pull the tray out and fill with water. Push the tray back in and attach the bottom trim panel. Do not operate the appliance unless the humidifier tray is installed.

During operation a small amount of condensation is produced in the flue system and drains into the humidifier tray.

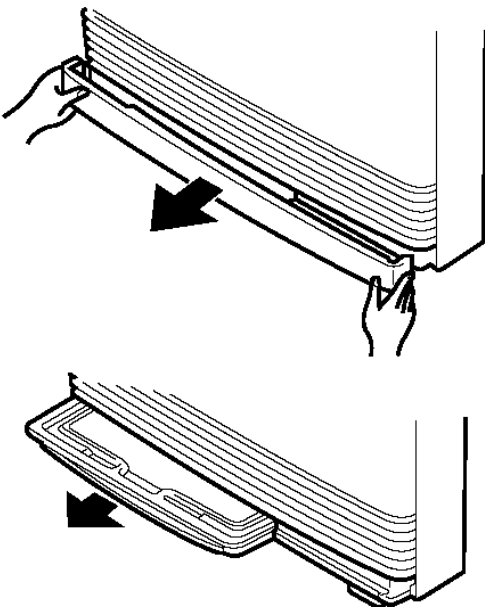

Sensible Temperature Control

The sensible temperature control feature allows comfortable heating which matches the conditions in the room.

Based on the information collected by the room temperature thermistor when the heating starts, the heating capacity is automatically adjusted to achieve a comfortable heating effect and to reach the temperature setting quickly.

Filter Lamp

If the filter lamp flashes during operation, check the air filter for dust. If dust is present, clean the filter. See the Care and Maintenance section. Turn the heater off before cleaning the filter. While the filter lamp is flashing, a beep is sounded every 5 minutes.

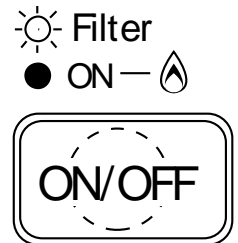

Adjusting Air Flow Direction

CAUTION Do not adjust the air flow louvers while warm air is flowing.

The vertical louvers may be adjusted to move the air flow more to the right or to the left.

Use a screw driver or similar object to bend each louver to the desired position.

Do not bend repeatedly (no more than 5 times) or else the louver will break.

The horizontal louver (which determines the vertical air flow direction) is fixed and cannot be adjusted.

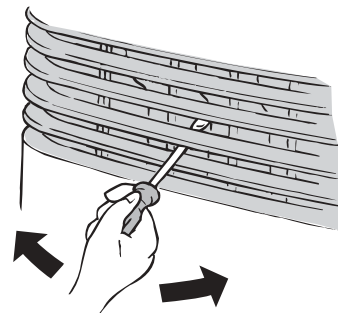

Care and Maintenance

Maintenance

All maintenance and service are to be performed by a qualified service technician, preferably one who has attended Rinnai service training classes on the Direct Vent products.

The appliance should be inspected annually by a qualified service technician. More frequent cleaning may be required due to excessive lint from carpeting, bedding material, etc. It is imperative that control compartments, burners, and circulating air passage ways of the appliance be kept clean.

Any screen or guard removed for servicing the appliance must be replaced prior to operating the appliance. Clean as follows:

1. Turn heat off. Allow to cool for one hour.
2. Remove the front panel by removing eight screws.
3. Use pressurized air to remove dust from the main burner, heat exchanger, and fan blades.
4. Use soft dry cloth to wipe cabinet.

Do not use wet cloth or spray cleaners on the burner.

The flue should be inspected annually for blockages or damage.

Motors are permanently lubricated and do not need periodic lubrication. Keep fan and motor free of dust and dirt by cleaning annually.

Verify proper operation after servicing.

Care of Exterior

Dampen soft cloth with warm water. Wring water out well and wipe the unit.

Do not use volatile substances such as benzene or thinners. They cause fading of the paint and deformation of the resin.

CAUTION

Prevent dust from accumulating on the power cord, side covers, and parts behind the appliance.

Snow Accumulation

Keep the area around flue terminal free of snow and ice. The appliance will not function properly if the intake air or exhaust is impeded by obstructions.

Refer to the Flue Terminal Clearances. The clearance in Ref. A should be maintained from any snow accumulation.

Filters

Dirty filters reduce the air flow and the appliance's ability to produce heat. The filters should be cleaned frequently during the heating season. If the filters become blocked the filter indicator lamp will flash and the appliance will beep. Eventually the appliance will turn off and display fault code 14 on the control panel display.

To clean the filters, the appliance should be OFF and cool. Remove the filter and clean it using a soft dry cloth or vacuum. If the filter is greasy wash with warm soapy water, rinse, and dry completely.

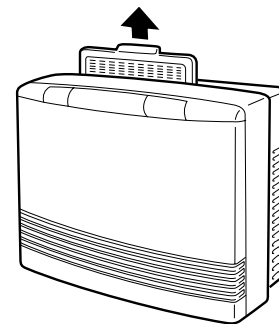

Visual Inspection of Flame

Check that the burner flames are operating normally. The flame can be seen through the circular window through the louvers.

When operating normally the burner flame should appear as long, clear, blue, stable, streaks. Yellow flames or an orange color is abnormal and maintenance is required.

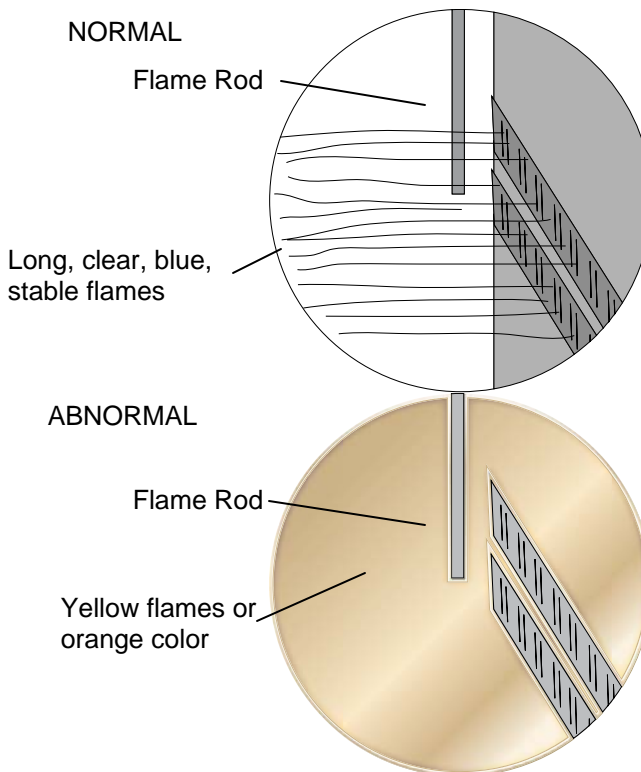

Before Making a Service Call

Before making a service call please check the following:

■ At Ignition:

Heater does not operate.	➔	Is the heater plugged in? Have the fuses or breaker blown at the fuse box / breaker panel? Is there a power failure? Is the air filter blocked? Is anything blocking the outlet for the hot air? Is the flue blocked?
Warm air does not flow when the burner lights.	➔	The fan is started automatically after a short delay. This is to allow the heat exchanger to warm up, helping to avoid cold draughts.
Smoke or strange smells are produced on the first trial light up after installation.	➔	This is caused by grease or oil and dust on the heat exchanger and will stop after a short time.
Sharp clicking noises at ignition, or when unit cuts down on the thermostat, or goes out.	➔	This is simply expansion noise from the heat exchanger.

■ During Combustion:

Clunking noise when the thermostat operates.	➔	This is the sound of the solenoid gas valves opening and closing.
Unit is not heating room.	➔	Is the air filter blocked? Is the set temperature high enough? Is the warm air outlet blocked by anything? Are the doors and windows of the room closed? Was the appliance correctly sized for the space?
Air filter is blocked or the louvers are blocked or obstructed.	➔	Allow heater to cool, clean air filter, operate again.
Heater will not re-ignite after overheating.	➔	Even after unit has cooled down, the heater does not ignite again. Repair is necessary. Contact a qualified / authorized service provider.

■ When the unit is turned off.

Convection fan continues to run after turning OFF.	➔	This is to remove the residual heat from the heat exchanger. The fan will stop when the heater cools down.
--	---	--

■ Other Points:

Steam is discharged from the flue terminal .	➔	High efficiency appliances tend to discharge water vapor on cold days. This is normal.
Unit cuts off without apparent reason.	➔	Check whether filters are blocked. Dirty filters will cause the heater to overheat.
Power Failure.	➔	Switch OFF, then ON again when power is restored to re-set controls.

Fault Codes

If there is a malfunction the appliance may shut down as a safety precaution and display a fault code to assist in diagnosing the problem. The fault code will flash in the display on the control panel. When making a service call, this code will assist with diagnosing the fault.

You may be able to clear the fault code by turning the heater off and then on again. If the fault code remains or returns on the next operation, contact Rinnai or your nearest service agent and arrange for a service call.

CODE DISPLAYED	FAULT	REMEDY
11	Ignition Failure	Check that gas is turned ON. Check that the vent termination is not blocked. Refer to the Restart Function explanation. Service call if repeated.
14	Overheat	Clean filter. Service call if repeated. [1]
16	Room Overheat	Lower room temperature to less than 104°F (40°C).
31	Room Temperature Sensor Faulty	Service call.
32		
33	Overheat Temperature Sensor Faulty	Service call.
34		
49	Sensor Breakdown	Service call.
53	Sparker Failure	Service call.
61	Combustion Fan Failure	Service call.
70	Faulty ON/OFF Switch	Service call.
71	Faulty Solenoids	Service call.
72	Faulty Flame Rod	Service call.
73	Communication Error	Turn heater OFF, then ON again.
99	Flue Block	Check around the flue terminal for blockage. [2]

[1] Remove any obstructions. The flue needs to be kept clear to expel exhaust gases. If the appliance fails to operate contact a qualified service agency.

[2] If the fusible link needs replacement, it must be done by a qualified service agency. In addition, the cause of the overheat needs to be determined. The fusible link is a one use safety device that breaks to shut off the appliance.

Restart Function

If the appliance fails to ignite, the appliance will attempt ignition after 1 hour. The “Ignition Failure” fault code, 11, will appear during that hour and disappears after a successful ignition. If ignition fails again, then the fault code will remain and another attempt to ignite will occur in 1 hour. The fault code is not stored in the fault code history.

If the flame is extinguished during forced combustion then the appliance will attempt ignition after 1 hour. The “Ignition Failure” fault code, 11, will appear during that hour and disappears after a successful ignition. Forced combustion takes place for about 15 seconds after ignition. After this time, the temperature control logic controls the combustion.

If the flame is extinguished (burner combustion failure) while the temperature control logic is operating the appliance, then the appliance will immediately attempt ignition. No fault code will appear.

Troubleshooting

Cause \ Problem	No ON indicator	Burner doesn't ignite	Unusual combustion	Combustion stops during operation	Smell of gas	Noisy ignition	Takes too long to warm the room	Remedy
Not Plugged In	●	●						Plug In
Power Failure	●	●		●				Push On/Off button to attempt restart after power is restored.
(Initial Installation) Air In Gas Pipe		●						Purge air (Installer)
Gas Filter Blocked		●	●				●	Service Call
Miss Ignition	●	●						Service Call
Flue terminal obstructed			●	●		●		Clear obstruction
Flue manifold not connected					●	●		Service Call
Louver obstructed				●			●	Clear obstruction
Air filter blocked				●			●	Clean filter
Gas Escape					●			Service Call
Function Lock Set		●						Cancel Function Lock
Gas turned off at meter, tank, or valve.	●	●						Turn gas on

Installation Instructions

General Instructions

WARNING

Do not use substitute materials.

Use only parts certified with the appliance.

- A qualified service technician should install the appliance and inspect it before use.
- If you move, check the gas type in your new area. The local gas authority will be able to advise on local regulations.
- The installation must conform with local codes or, in the absence of local codes, with the *National Fuel Gas Code, ANSI Z223.1/NFPA 54*, or the *Natural Gas and Propane Installation Code, CSA B149.1*.
- A manufactured home (USA only) or mobile home OEM installation must conform with the *Manufactured Home Construction and Safety Standard, Title 24 CFR, Part 3280*, or, when such a standard is not applicable, the standard for *Manufactured Home Installations, ANSI/NCSCBS A225.1*, or the standard for *Gas Equipped Recreational Vehicles and Mobile Housing, CSA Z240.4*.
- The appliance, when installed, must be electrically grounded in accordance with local codes or, in the absence of local codes, with the *National Electrical Code, ANSI/NFPA 70*, or the *Canadian Electrical Code, CSA C22.1*.
- Appliance input ratings are based on sea level operation and need not be changed for operation up to 2000 ft (609.9 m) elevation. For operation at elevations above 2000 ft (609.9 m), refer to the Conversion Manual.
- The appliance and its appliance main gas valve must be disconnected from the gas supply piping system during any pressure testing of that system at test pressures in excess of 1/2 psi (3.5 kPa).
- The appliance must be isolated from the gas supply piping system by closing its equipment shutoff valve during any pressure testing of the gas supply piping system at test pressures equal to or less than 1/2 psi (3.5 kPa).
- If the flooring is carpet, tile, or other combustible material other than wood, then the appliance must be installed on a metal or wood panel extending the full width and depth of the appliance.
- This appliance discharges a large volume of warm air next to the floor. Any particles in the air such as cigarette smoke could cause discoloration in nylon carpets containing dyes or vinyl surfaces.
- This appliance is not designed to be built in.
- This appliance is only for use with the type of gas indicated on the rating plate. This appliance is not convertible for use with other gases unless a certified kit is used. If conversion of the unit is needed, conversions must be performed by a qualified service provider at the owner's expense.
- This appliance must not be connected to a chimney flue serving a separate solid-fuel burning appliance.
- Rinnai suggests that a dedicated electrical circuit with a 120VAC, 60 hz, 10 amp power source be used.
- Two 1/8 in test plugs are provided for testing of manifold differential pressure. They are located on the modulating gas valve and on the burner manifold.
- The appliance should be correctly sized for the space it is required to heat.
- Follow the installation instructions and those in *Care and Maintenance* for adequate combustion and ventilation air.
- The flow of combustion and ventilation air shall not be obstructed.
- Clearances to access the appliance during servicing are 2 inches (50 mm) from the sides, 40 inches (1 m) from the front, and 9 inches (225 mm) from the top.

NOTICE

If installation is at a location above 2001 ft (610 m), then follow the Adjust Gas Pressure Settings procedure in the Conversion Manual.

If installation is at or below 2000 ft (610 m) then the pressure settings do not need to be adjusted.

Gas Connection

WARNING

When connecting the gas valve or other gas components in the gas line, use a backup wrench to ensure the connection is gas tight.

- The gas supply line shall be gas tight, sized and so installed as to provide a supply of a gas sufficient to meet the maximum demand of the heater without loss of pressure.
- A shut off valve and appliance connector valve should be installed in the upstream of the gas line to permit servicing.
- Flexible pipe and any appliance connector valve used for gas piping shall be types approved by nationally recognized agencies.
- Any compound used on the threaded joint of the gas piping shall be a type which resists the action of liquefied petroleum gas (propane / LPG).
- After completion of gas pipe connections all joints including the heater must be checked for gas tightness by means of leak detector solution, soap and water, or an equivalent nonflammable solution, as applicable. (Since some leak test solutions, including soap and water, may cause corrosion or stress cracking, the piping shall be rinsed with water after testing, unless it has been determined that the leak test solution is non-corrosive.)
- Check the gas supply pressure immediately upstream at a location provided by the gas company. Supplied gas pressure must be within the limits shown in the Specifications section.
- Refer to an approved pipe sizing chart if in doubt about the size of the gas line.
- Install manual gas cut-off valve so that it can be accessed for easy operation. Do not conceal manual cut-off valve behind back spacer.

Clearances to Combustibles

When determining where to install the appliance the clearances to combustibles shown in the figure must be followed. Also refer to the Safety Behaviors and Practices section. The clearance to combustibles from the top is zero.

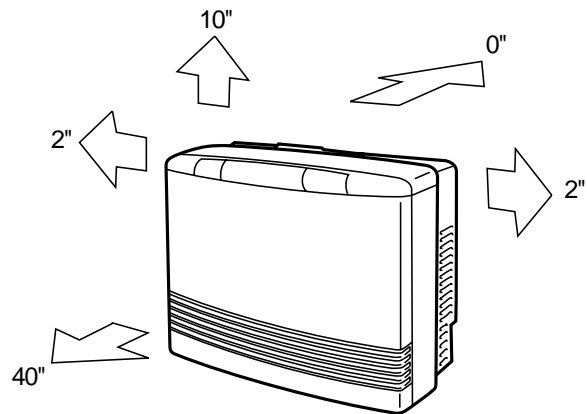

Attach Back Covers (Sides Only)

Attach back covers as shown.

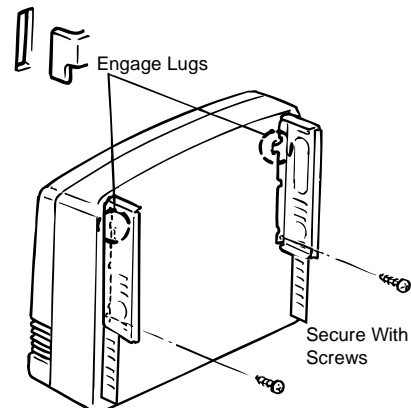

Flue Terminal Clearances

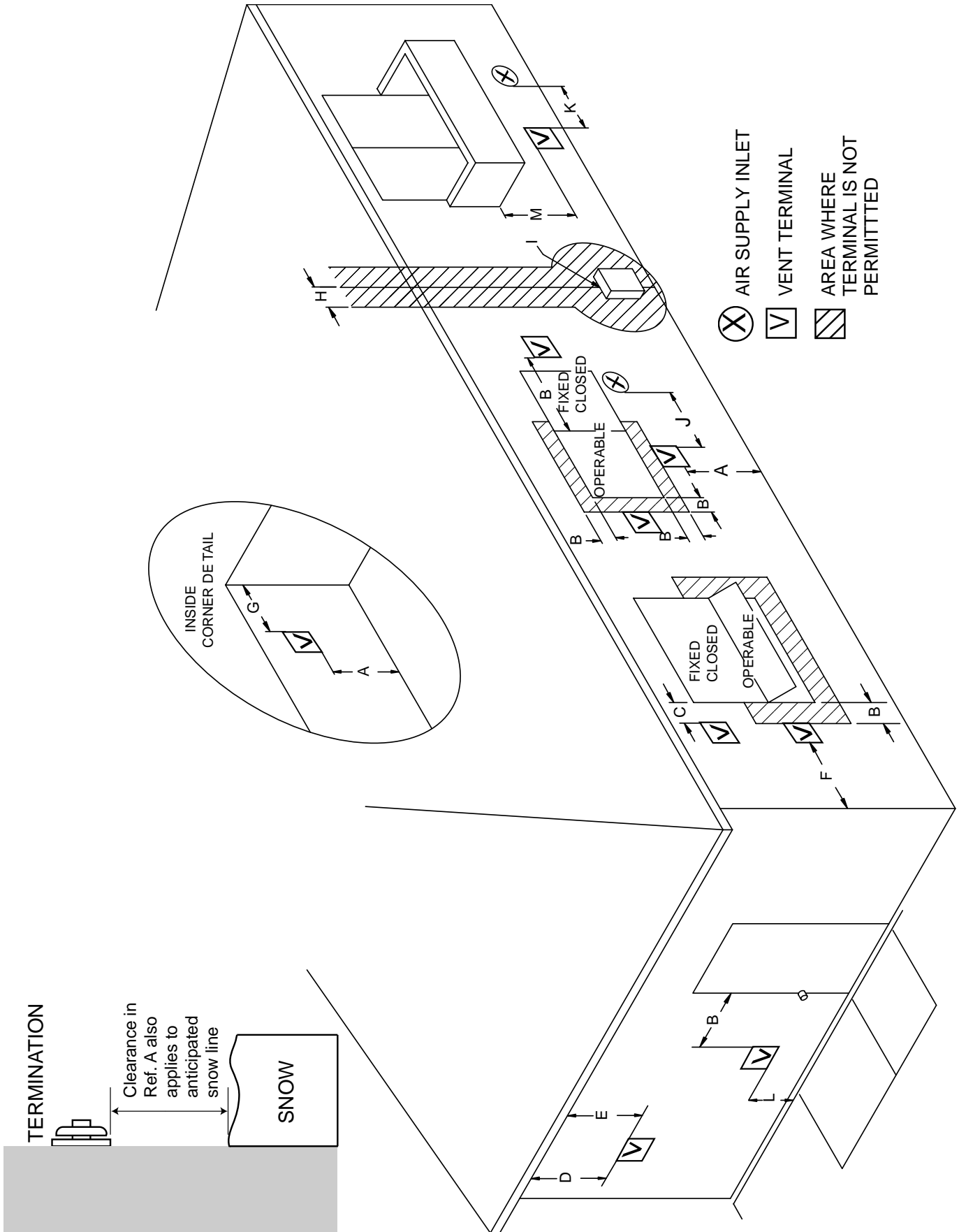

Flue Terminal Clearances

- ① A vent shall not terminate directly above a sidewalk or paved driveway that is located between two single family dwellings and serves both dwellings.
- ② Permitted only if veranda, porch, deck, or balcony is fully open on a minimum of two sides beneath the floor.
- * For clearances not specified in ANS/ Z223.1/NFPA 54 or CSA B149.1, clearances are in accordance with local installation codes and the requirements of the gas supplier.

Ref	Description	Canadian Installations	US Installations
A	Clearance above grade, veranda, porch, deck, or balcony. (Take into account the anticipated snow line)	6 inches (15 cm) for appliances ≤ 10,000 BTUh; 9 inches (23 cm) for appliances > 10,000 BTUh and ≤ 50,000 BTUh, 12 inches (30 cm) for appliances > 50,000 BTUh	6 inches (15 cm) for appliances ≤ 10,000 BTUh; 9 inches (23 cm) for appliances > 10,000 BTUh and ≤ 50,000 BTUh, 12 inches (30 cm) for appliances > 50,000 BTUh
B	Clearance to window or door that may be opened	12 inches (30 cm)	9 inches (23 cm)
C	Clearance to permanently closed window	*	*
D	Vertical clearance to ventilated soffit, located above the terminal within a horizontal distance of 2 feet (61 cm) from the center line of the terminal	*	*
E	Clearance to unventilated soffit	*	*
F	Clearance to outside corner	*	*
G	Clearance to inside corner	20 inches (50 cm)	20 inches (50 cm)
H	Clearance to each side of center line extended above meter/regulator assembly	3 feet (91 cm) within a height 15 feet (4.5 m) above the meter/regulator assembly	*
I	Clearance to service regulator vent outlet	3 feet (91 cm)	*
J	Clearance to nonmechanical air supply inlet to building or the combustion air inlet to any other appliance	12 inches (30 cm)	9 inches (23 cm)
K	Clearance to a mechanical air supply inlet	6 feet (1.83 m)	3 feet (91 cm) above if within 10 feet (3 m) horizontally
L	Clearance above paved sidewalk or paved driveway located on public property	7 feet (2.13 m) ①	*
M	Clearance under veranda, porch, deck, or balcony	12 inches (30 cm) to non-flammables ② 24 inches (60 cm) to flammables ②	12 inches (30 cm) to non-flammables ② 24 inches (60 cm) to flammables ②

Flue Terminal Clearances

Minimum clearances and distances from obstructions are shown.

Follow local codes and regulations.

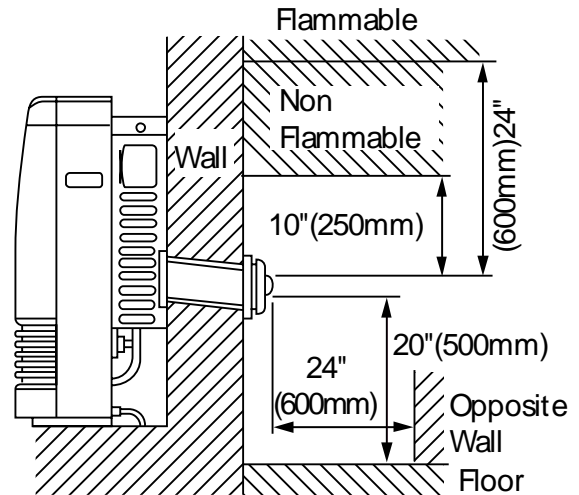



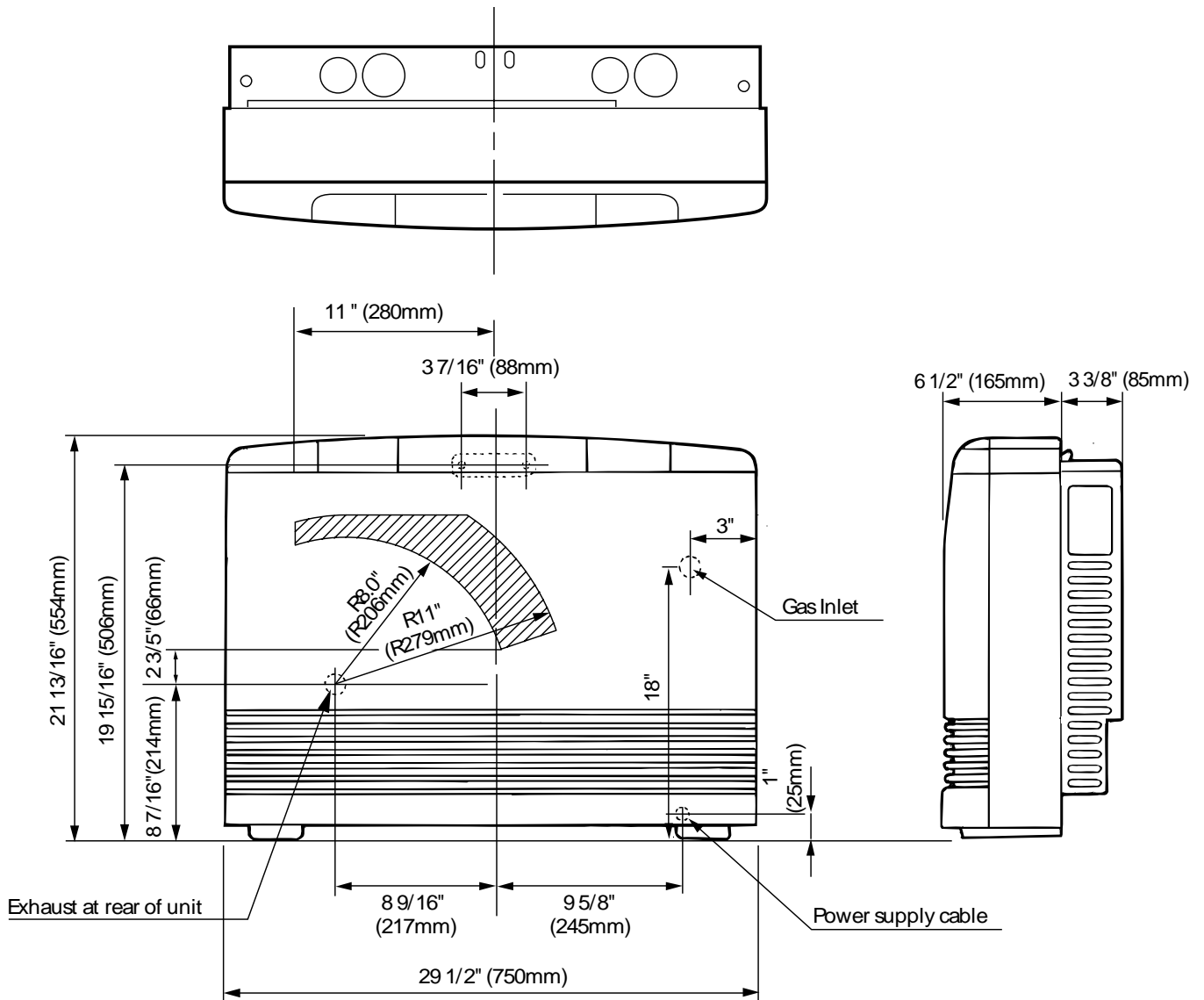



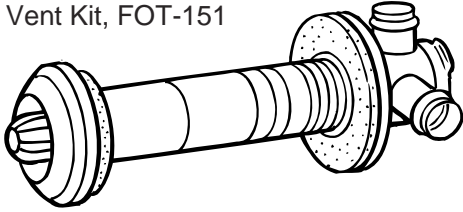

Dimensions

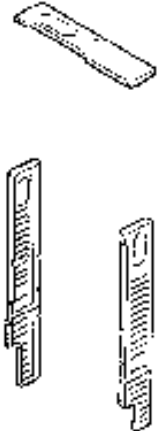
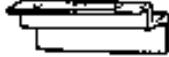

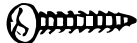
Installation Parts

The following items are included with the appliance:

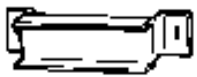
Flue Manifold1 "A" Vent Kit, FOT-151		Spare rubber seal1 ('A' Flue units only)		
		 (For weatherboard installations)		
Back Spacer Set		1	Spacer Bracket 	1
		1	Pipe Stopper 	1
		1	Manual Valve Set 	1
		5	Screw  (For Wall Bracket and Flue manifold)	5
Insulation Clip		1	Screw  (For Back Spacer)	10
Plastic tie for air inlet		1	Screw  (For Flue Manifold)	3
Wall Bracket		1	Owner's Manual Conversion Manual	1

The following flue manifold sizes are available for different wall thicknesses:

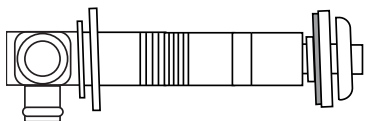

Name	Kit No.	fits walls
S Vent Kit	FOT-150	3 - 4 1/2 in (75 - 115 mm)
A Vent Kit	FOT-151	4 1/2 - 9 1/2 in (115 - 240 mm)
B Vent Kit	FOT-152	9 1/2 - 15 3/4 in (240 - 400mm)
C Vent Kit	FOT-153	15 3/4 - 23 5/8 in (400 - 600 mm)
D Vent Kit	FOT-154	23 5/8 - 31 1/2 in (600 - 800 mm)

Drilling Flue Hole

NOTICE Use a template (included) to determine allowable location of the flue hole

For installation without using extension kits, the configuration of the flue manifold, air intake hose, and exhaust slide pipe should be as shown when installation is completed.

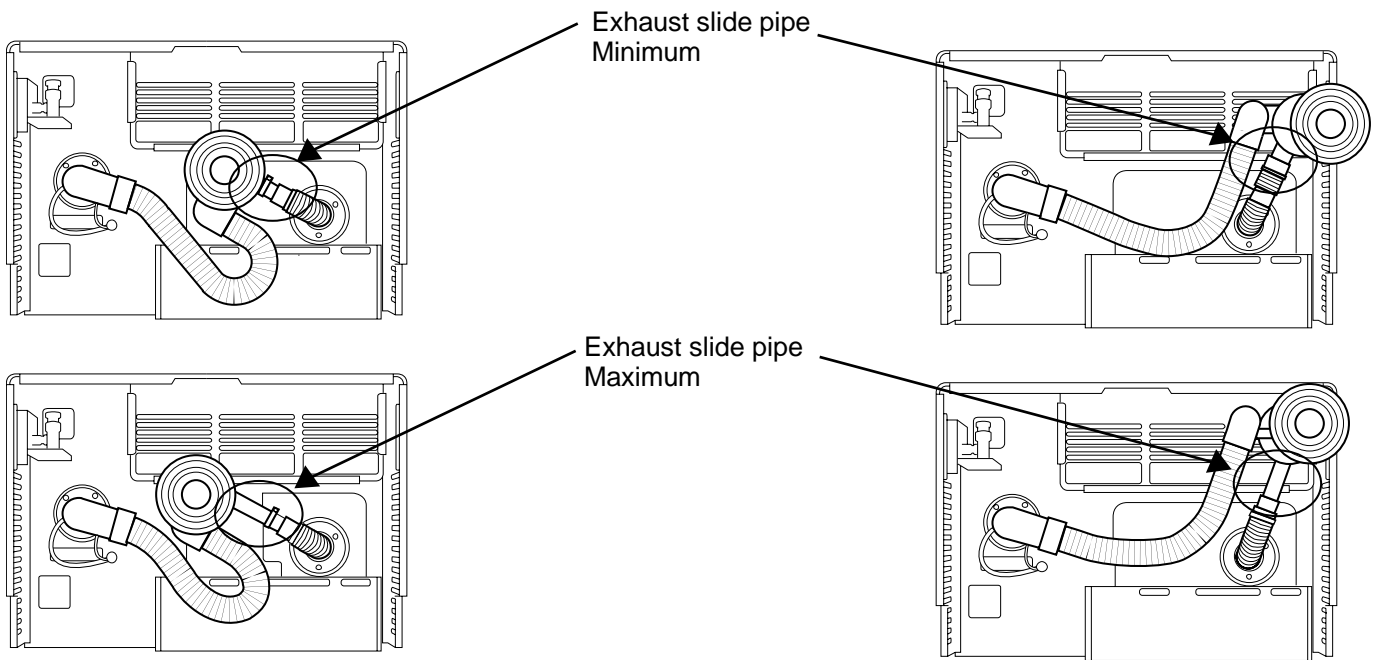

Ensure that there are no gas or water lines, or electrical circuits in the wall location where the flue hole is to be drilled.

Drill the flue hole using a 3 1/8 inch (80 mm) drill. The center of the hole must be located anywhere within the shaded area, unless extension kits are used. See diagram.

For weatherboard walls, drill through the center of the weatherboard from the outside first and then through the plasterboard. A template is provided.

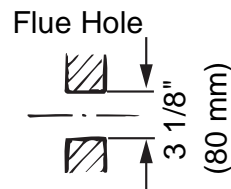

Flue Manifold Installation

- The flue manifold must exhaust to the outside. Do not exhaust into other rooms.
- The flue manifold is not designed to be positioned under floors or below the heater.
- The termination cannot be vertical.
- This appliance can only be used with one of the five types of Rinnai flue kits. The flue kits and their dimensions are listed on the previous page.
- Refer to the Flue Terminal Clearances section.

1. Disassemble the flue manifold

The flue consists of 3 parts:

- sleeve
- inside connection
- outside terminal

Disassemble the flue manifold by first pulling out the inside connection. To remove the outer terminal pull and release the two internal ties and then pull out the outer terminal.

Clearance to combustibles for the sleeve and flanges is zero inches.

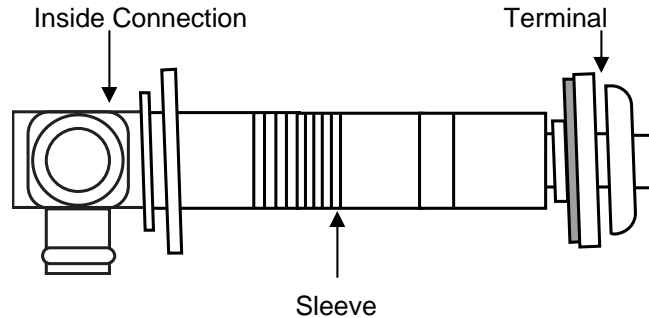

2. Adjust the sleeve length

Measure wall thickness through previously drilled 3 1/8 inch (80 mm) hole.

The end of the sleeve should protrude 3/16 - 3/8 inch (5-10 mm) from the outside wall.

The sleeve is threaded for adjustment. Adjust the sleeve length to wall thickness plus 3/16 - 3/8 inch (5-10 mm).

NOTE: Do not extend beyond the red line.

For other than the "S" type flue manifold, if a shorter length is necessary an extension can be removed. Cut the plastic and remove the extension.

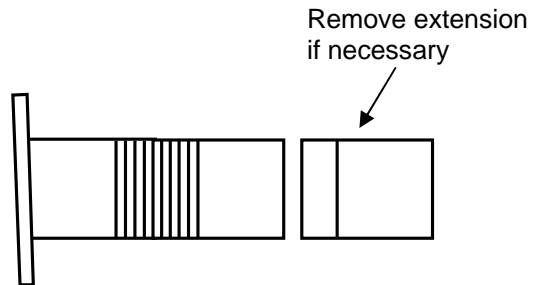

3. Attach the sleeve

Attach to the inside wall using 3 screws arranging the flange so that the marking "TOP" is at the top.

The flange is offset 2° to allow the condensate drain to the outside.

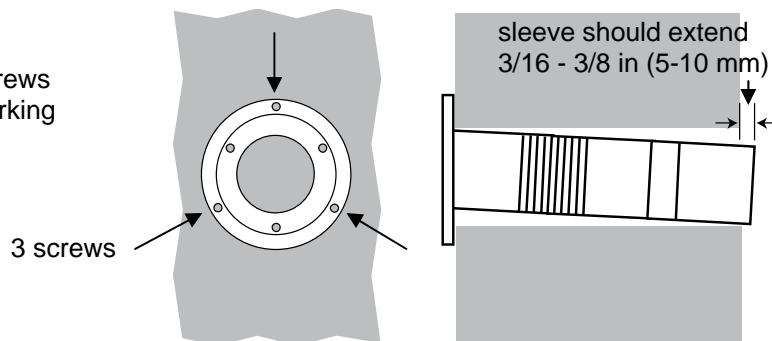

Flue Manifold Installation

4. Install the Terminal

Check that the terminal seal is in place. For weatherboard walls, add the second seal next to the terminal seal to compensate for weather board angle.

From the outside insert the terminal into the sleeve with the marking "TOP" at the top. The left hand side locking tie should be marked "LEFT".

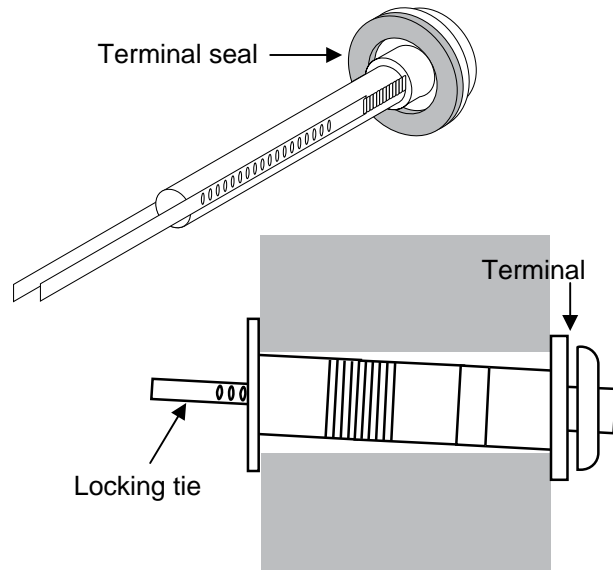

5. Lock the ties

Pulling hard on the left and right hand ties, clip the ties over the notches inside the sleeve. You should be able to pull the ties 2 or 3 notches past the starting point. Cut the ties, leaving about 3/4 inch (20 mm) past the notch. Bend the ties back into the sleeve and parallel to the wall.

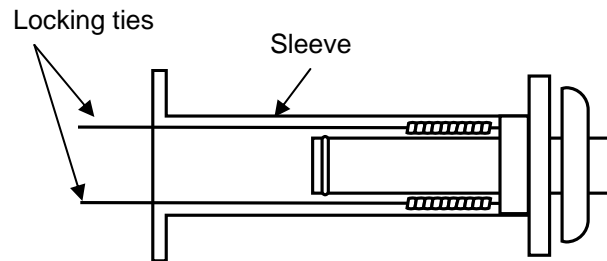

6. Insert Inside Connection Assembly

Push the assembly into the terminal tube, ensuring that the seal is in place on the inner tube.

Attach the inside connection with 3 screws. The inner connection can still be turned to install the screws.

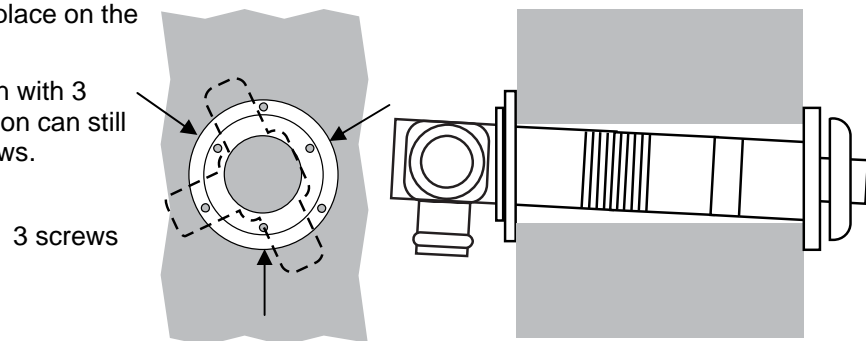

Extension Kit Installation

If necessary, extension kits are available to extend the exhaust line and air intake hose between the manifold and the appliance.

- (1) Maximum vent length allowed is 13 feet (4 m).
- (2) Maximum vertical length allowed is 8 feet (2.4 m).
- (3) Any length (horizontal and vertical) in excess of 8 feet (2.4 m) must be sloped 3° downward toward the flue manifold to allow condensate to drain to the outside.
- (4) Do not allow any low points in the exhaust line where condensate will collect.

- (5) Vent extensions installed in unconditioned air space must be insulated with high temperature insulation and must be accessible.
- (6) Vent extensions must not be concealed per NFPA 54 and must be accessible allowing inspection and repair. Decorative covers are available from Rinnai.

These figures show the 3 possible ways that the extension exhaust line and air intake hose may be directed away from the appliance. All 3 views are from behind the appliance.

For your configuration, position the air intake hose as shown.

Horizontal extension on left side

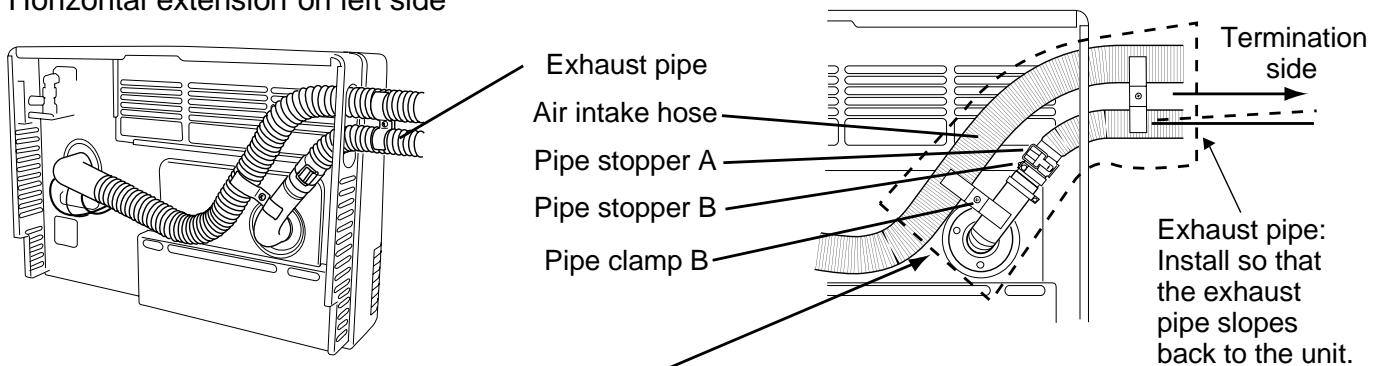

Do not allow contact between the air intake hose and exhaust pipe.

Vertical extension on right side

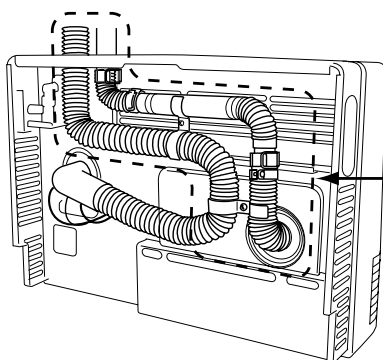

Vertical extension on left side

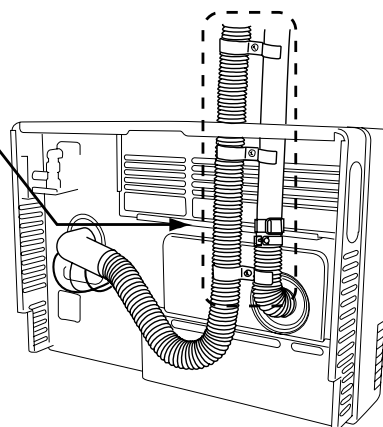

Extension Kit Installation

CAUTION Use the pipe stoppers, connectors, clamps, and screws according to these instructions in order to ensure no leakage of exhaust gases.

Clearances

exhaust pipe to combustibles	1 inch (25.4 mm)
exhaust pipe to non-combustibles	zero

Clamps

Both the exhaust line and air intake hose are supported by clamps which are attached to the wall. A wall fixture can be used to offset the clamp from the wall. Use Screw B to attach the wall fixture to the wall. If the wall fixture is not used then use Screw A and the nut to attach the clamp to the wall.

The air intake hose should always be underneath the exhaust line so that in case the air intake hose sags it will not come into contact with the exhaust line.

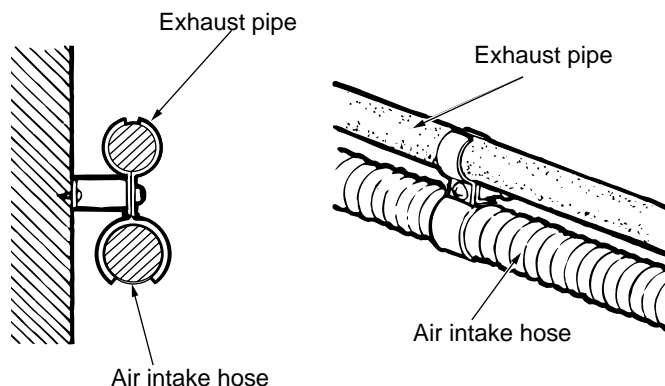

Installing the Exhaust Line

The exhaust line is connected between the bent pipe at the rear of the heater and the exhaust port on the flue manifold.

To connect exhaust pipes with other straight pipes or bends, fit the male end into the female end. Use pipe stopper A to clamp the connection.

Use pipe stopper B to fix the length on the adjustable exhaust pipes. Do not extend these pipes beyond the red line.

Do not cut the exhaust pipe. Use the adjustable pipes if necessary.

To bend the elbow, insert exhaust pipes into both ends for additional leverage. Bend to desired angle.

Do not straighten the bent pipe attached to the appliance.

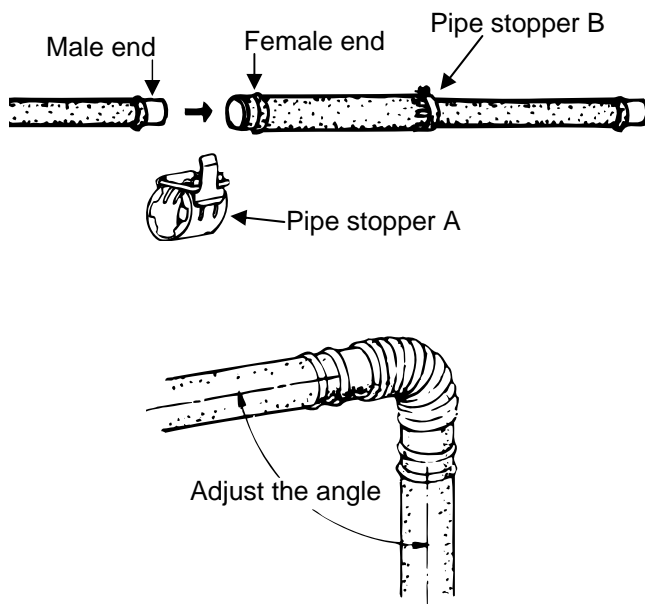

Connecting the Air Intake Hose

The air intake hose is connected between the air connection at the rear of the heater and the air intake port on the flue manifold.

Push the air intake hose onto the flue manifold and secure with the plastic cable tie.

Join air intake hoses by screwing the hose joint half of its length into the air intake hose and then screwing another air intake hose into the hose joint.

The lengths of the air intake hose and the exhaust pipe must be the same in order for the appliance to operate properly. The hose can be cut to the required length. Deburr all rough edges. Do not cut the hose attached to the appliance.

Support the air intake hose with pipe clamps.

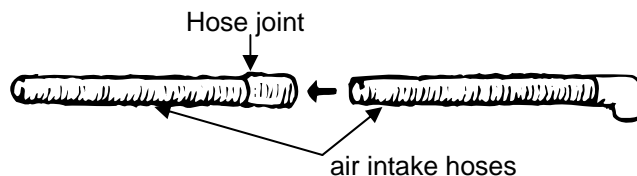

NOTICE Do not cut the intake hose. Cutting the intake hose may result in noise.

Extension Kit Installation

Extension Kits and Parts



① EXHAUST PIPE (ADJUSTABLE)



② EXHAUST PIPE (NON ADJUSTABLE)



③ AIR INTAKE HOSE



④ BENT ELBOW

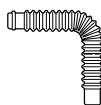

⑤ LONG BENT ELBOW



⑥ HOSE JOINT



⑦ PIPE STOPPER A



⑧ PIPE STOPPER B



⑨ PIPE CLAMP



⑩ WALL-FIXTURE



⑪ NUT



⑫ SCREW A



⑬ SCREW B

Item	Description	FOT-219	FOT-220	FOT-221	FOT-158	FOT-222
1	Exhaust Pipe (adjustable) 11.4-20.3 in (290-515 mm)	1				
1	Exhaust Pipe (adjustable) 21.0-39.6 in (533-1005 mm)		1	1		
2	Exhaust Pipe - 40 in (1016 mm)			1		
3	Air Intake Hose - 29.5 in (750 mm)	1				
3	Air Intake Hose - 49.2 in (1.25 m)		1			
3	Air Intake Hose - 90.6 in (2.3 m)			1		
4	Bent Elbow				1	
5	Long Bent Elbow					
6	Hose Joint	1	1	1		
7	Pipe Stopper A	1	1	2	1	
8	Pipe Stopper B	1	1	1		
9	Pipe Clamp	3 sets	4 sets	5 sets		1 set
10	Wall Fixture	2	3	4		1
11	Nut	3	4	5		1
12	Screw A	3	4	5		1
13	Screw B	4	6	8		2

Connecting the Appliance

1. Attach the air inlet hose to the flue manifold on either inlet position "a" or "b".

The unused inlet is plugged with the rubber cap supplied on the manifold.

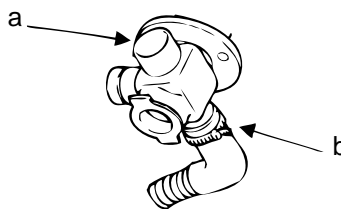

2. Connect the flue elbow to the manifold while moving the appliance into position.

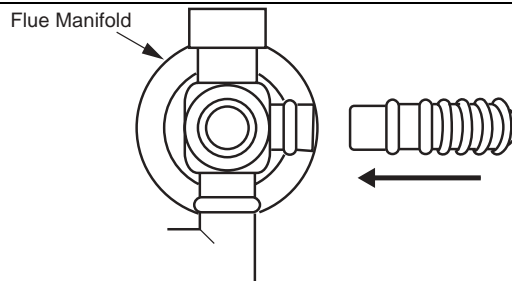

3. Fit the pipe stopper over the connection between the flue elbow and the manifold. Engage the hook and rotate it until it snaps against the body of the clamp.

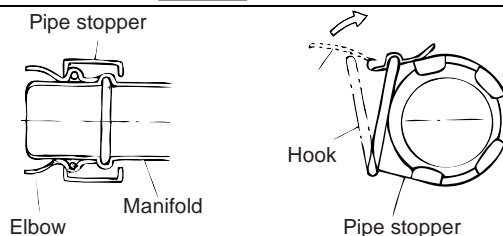

4. Slide the insulation sleeve up to the flue manifold and slip the securing clip over the sleeve as shown.

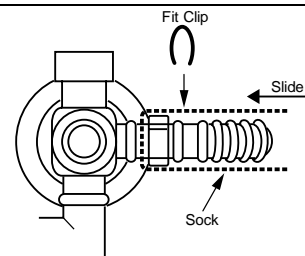

5. Install the bracket on the rear of the top spacer by tightening 2 screws.

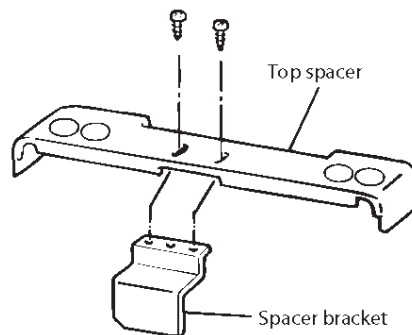

6. Install the wall bracket with two screws. Install the top spacer by clipping the spacer into the wall brackets and attaching it to the heater with 2 screws.

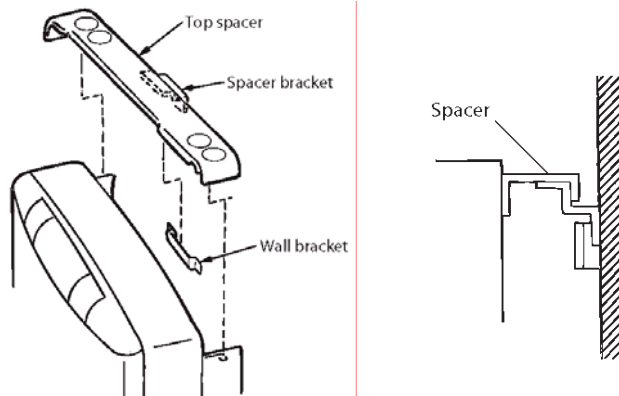

FOR YOUR SAFETY READ BEFORE OPERATING





WARNING

If you do not follow these instructions exactly, a fire or explosion may result causing property damage, personal injury or loss of life.

- A. This appliance does not have a pilot. It is equipped with an ignition device which automatically lights the burner. Do not try to light the burner by hand.
- B. **BEFORE OPERATING** smell all around the appliance area for gas. Be sure to smell next to the floor because some gas is heavier than air and will settle on the floor.

WHAT TO DO IF YOU SMELL GAS
 - Do not try to light any appliance.
 - Do not touch any electric switch; do not use any phone in your building.
 - Immediately call your gas supplier from a neighbor's phone. Follow the gas supplier's instructions.
- If you cannot reach your gas supplier, call the fire department.
- C. Use only your hand to push in or turn the gas control knob. Never use tools. If the knob will not push in or turn by hand, do not try to repair it, call a qualified service technician. Force or attempted repair may result in a fire or explosion.
- D. Do not use this appliance if any part has been under water. Immediately call a qualified service technician to inspect the appliance and to replace any part of the control system and any gas control which has been under water.

OPERATING INSTRUCTIONS

1. **STOP!** Read the safety information above.
2. Set the thermostat to lowest setting.
3. Turn off all electric power to the appliance using the ON/OFF button.
4. This appliance is equipped with an ignition device which automatically lights the burner. Do not try to light the burner by hand.
5. Locate the manual gas valve on the side of the heater. Turn the manual valve clockwise to the full OFF position. 
6. Wait five (5) minutes to clear out any gas. Then smell for gas, including near the floor. If you smell gas, STOP! Follow "B" in the safety information above. If you don't smell gas, go to the next step.
7. Turn the manual gas valve counterclockwise to the full ON position. 
8. Turn on all electric power to the appliance using the ON/OFF button.
9. Set the thermostat to desired setting.
10. Combustion indicator glows red when the burner is lit and flashes when the burner fails to ignite. If the appliance will not operate, follow the instructions "To Turn Off Gas To Appliance" and call your service technician or gas supplier. See manual for additional information.

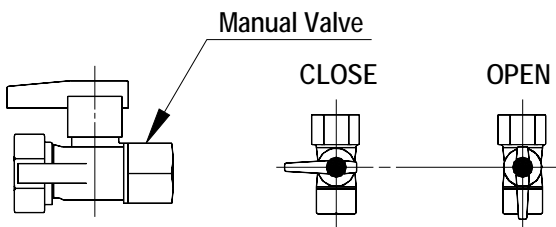

TO TURN OFF GAS TO APPLIANCE

1. Set the thermostat to lowest setting.
2. Turn off all electric power to the appliance using the ON/OFF button.
3. Locate the manual gas valve on the side of the heater. Turn the manual valve clockwise to the full OFF position. 

NOTE: The fan will continue to operate until the appliance is cool. Do not turn the appliance off by unplugging it from the wall. Keep burner and control compartment clean. See installation and operating instructions.

Cut-Away Diagram

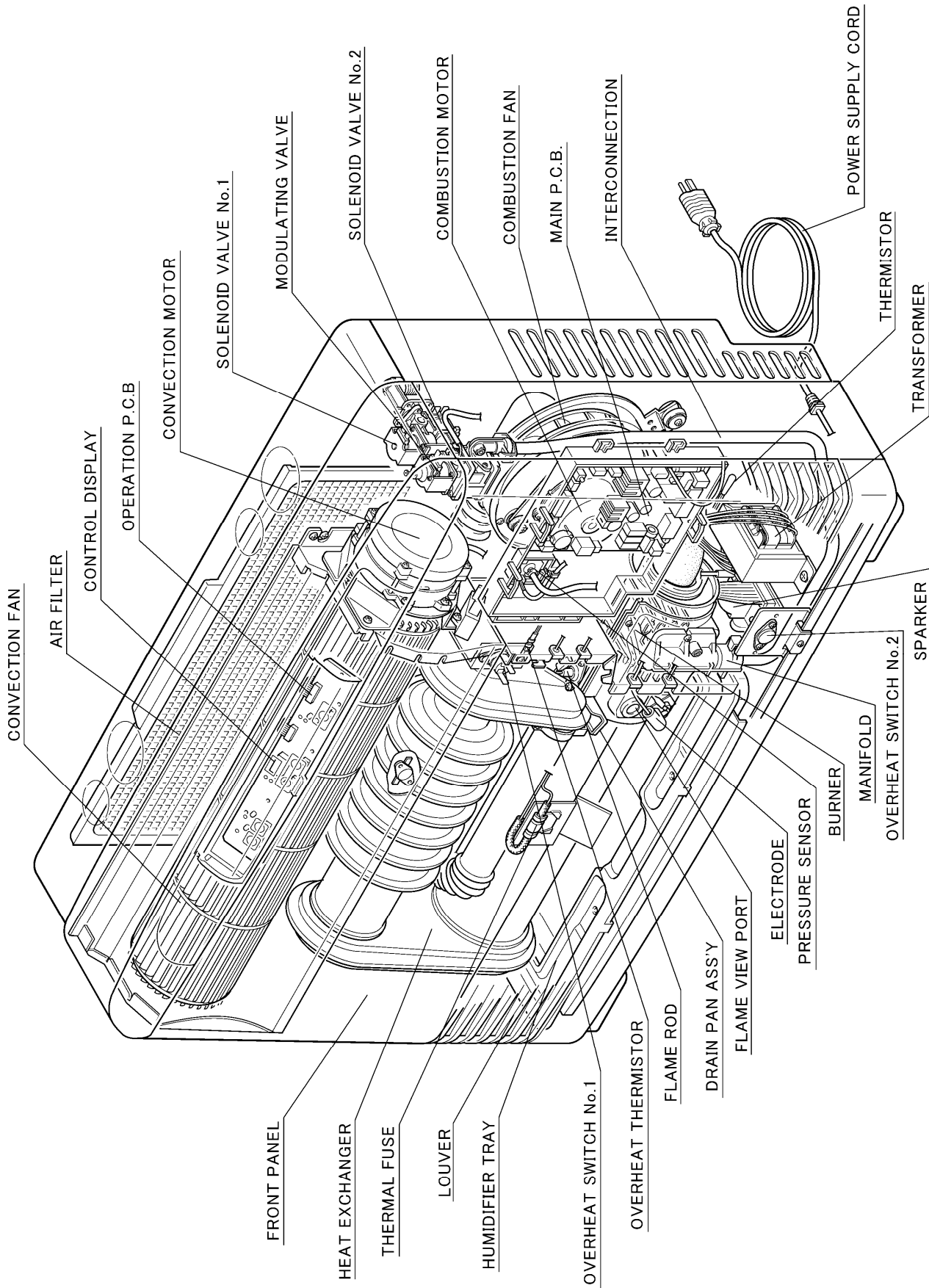

Wiring Diagram

CAUTION

Label all wires prior to disconnection when servicing controls. Wiring errors can cause improper and dangerous operation.

If any of the original wire as supplied with the appliance must be replaced, it must be replaced with type 18 AWG wire or its equivalent.

MARK	PART NAME	MARK	PART NAME
MS	MAIN SWITCH	OH.TH	OVER HEAT THERMISTOR
R.TH	THERMISTOR	OHS1, 2, 3	OVER HEAT SWITCH 1, 2, 3
TF	THERMAL FUSE	FM	CONVECTION FAN MOTOR
F	FUSE	SP	SPARKER
ER	ELECTRODE	SV1, 2	MAIN SOLENOID VALVE 1, 2
POV	MODULATING SOLENOID VALVE	BL	COMBUSTION FAN MOTOR
TR	TRANSFORMER	PS	PRESSURE SENSOR
FR	FLAME ROD		

CODE	COLOR
bk	black
bl	blue
gr	green
gr/y	green/yellow
r	red
w	white
y	yellow
gy	gray
or	orange

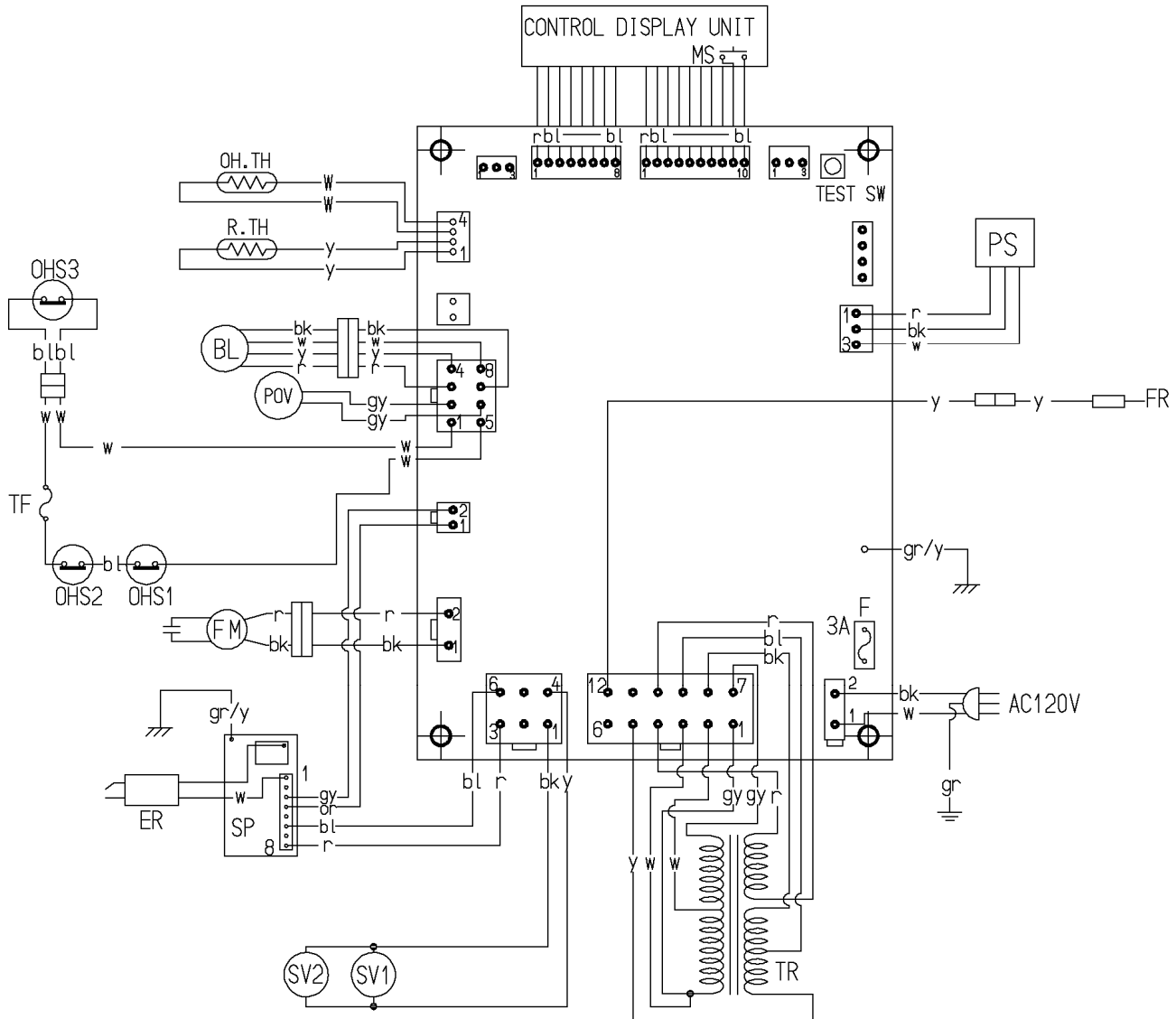

Flow Diagram

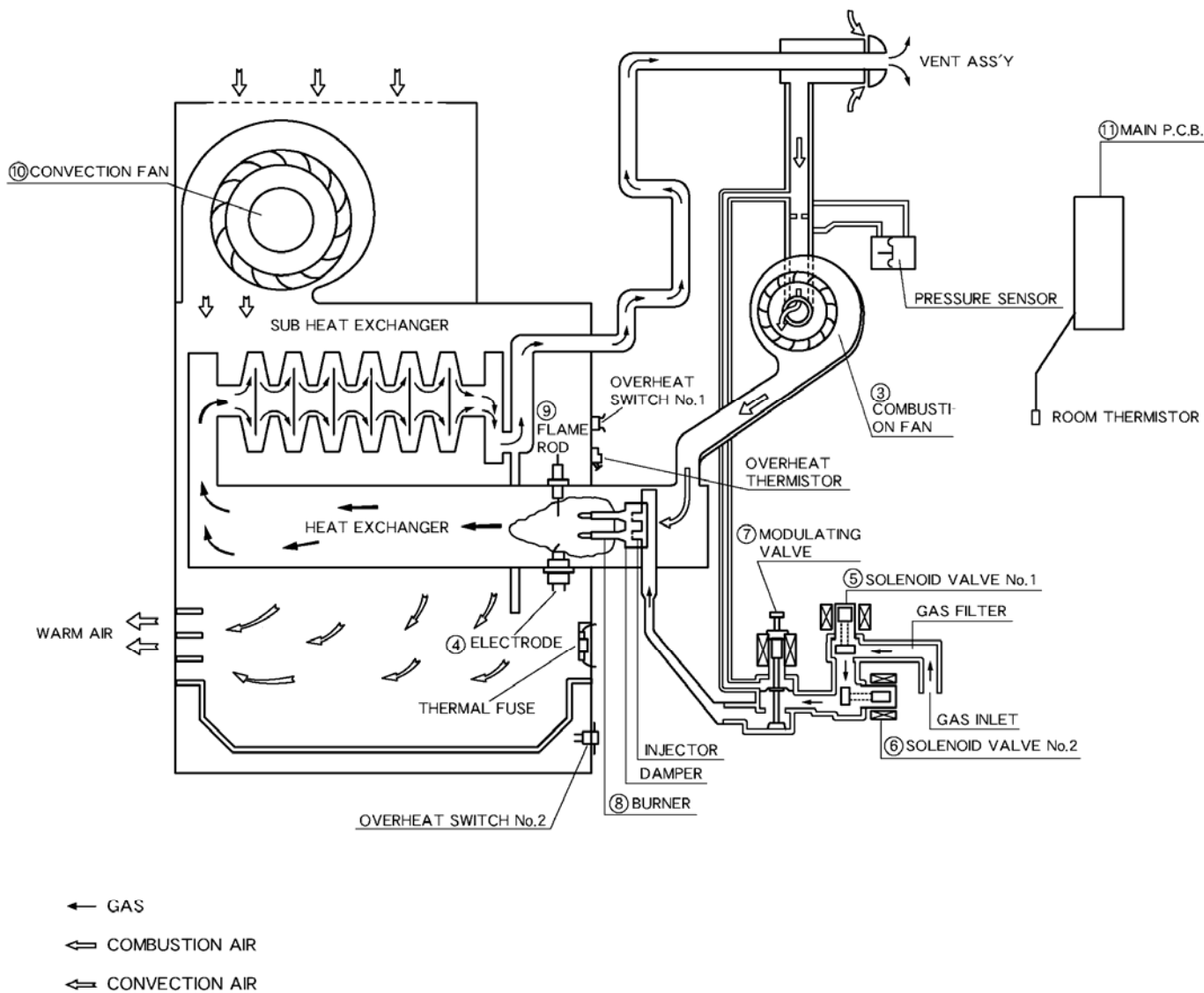

Parts List

For replacement parts call Rinnai at 1-800-621-9419.

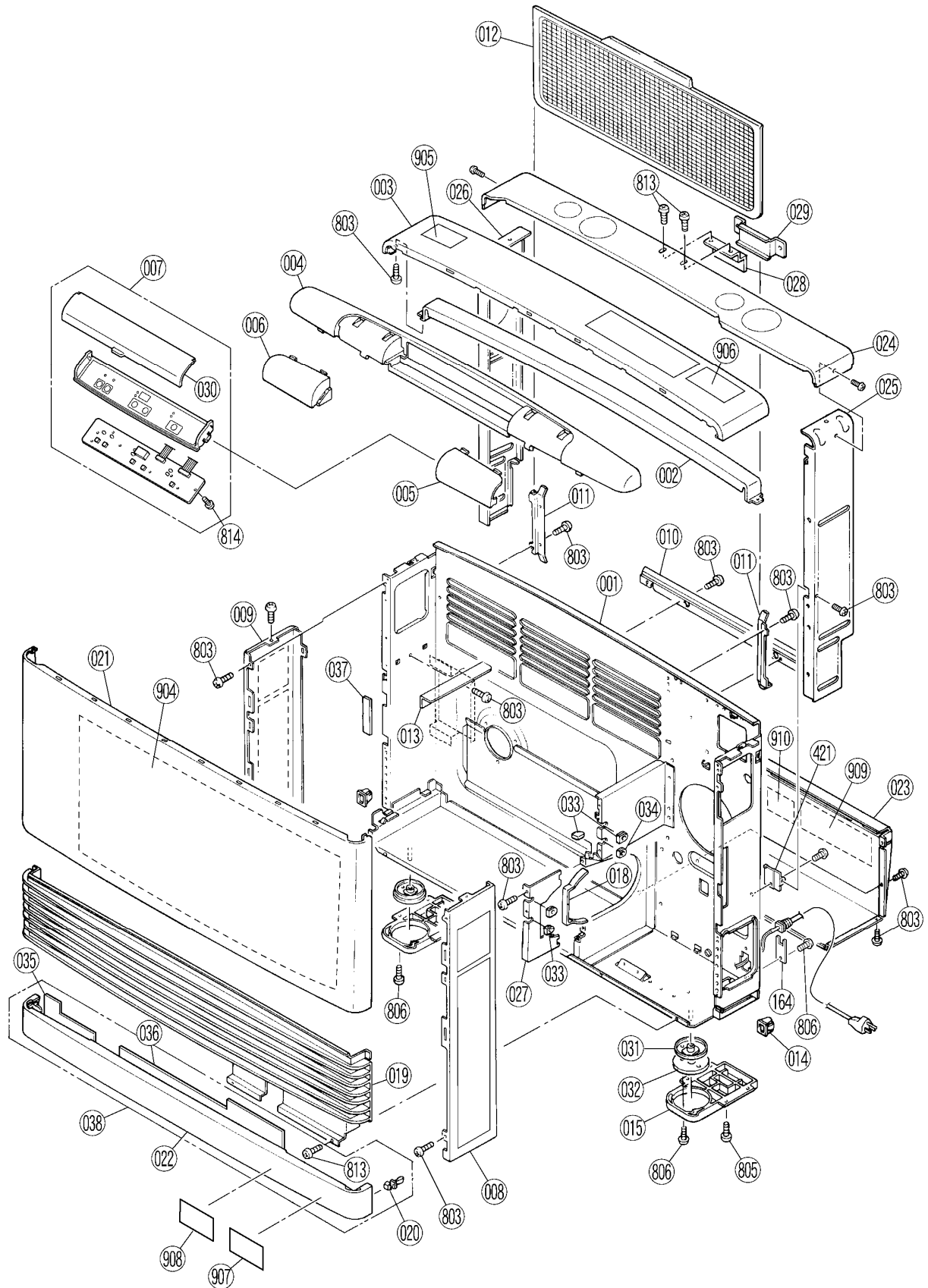

Parts List

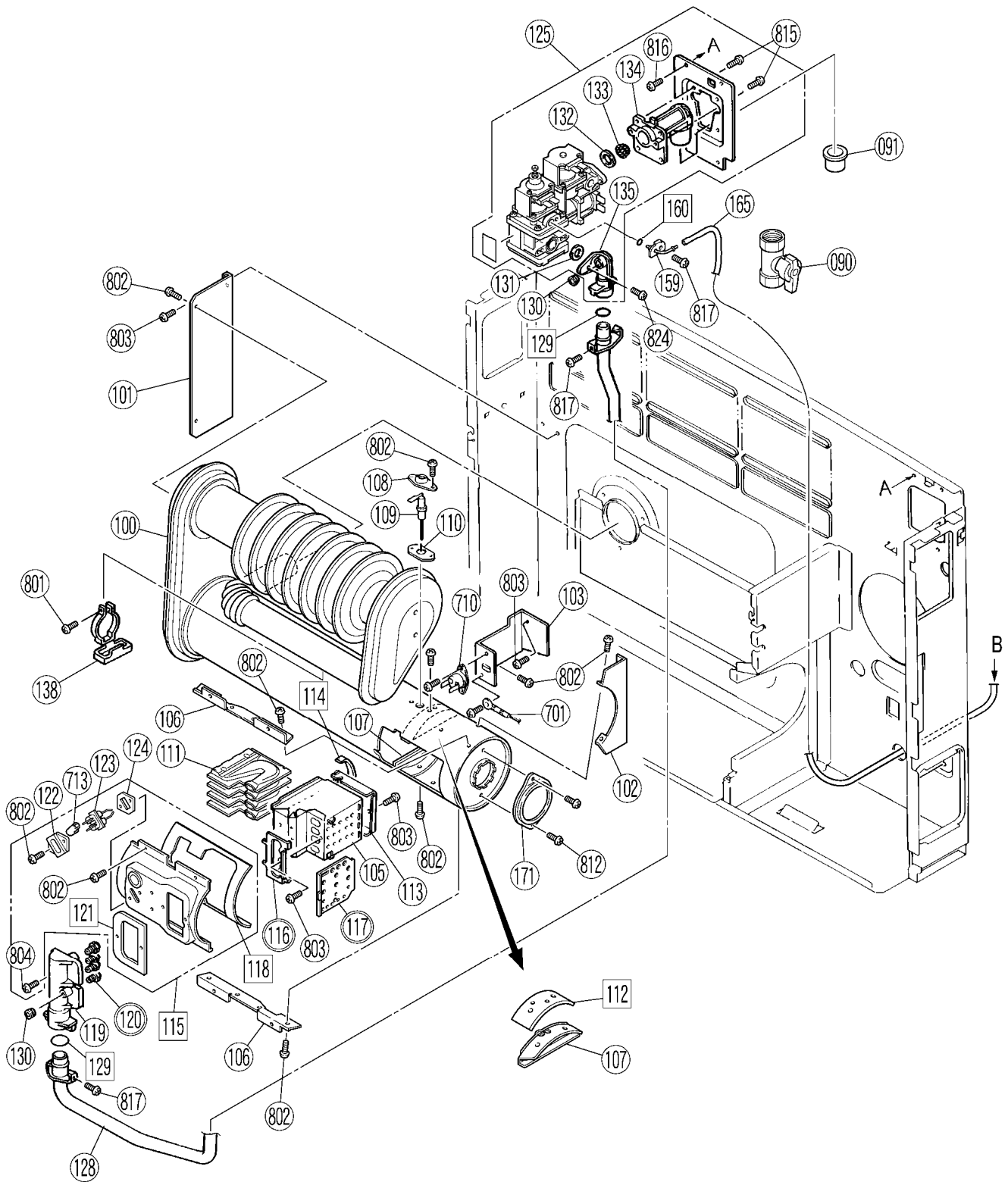

Parts List

For replacement parts call Rinnai at 1-800-621-9419.

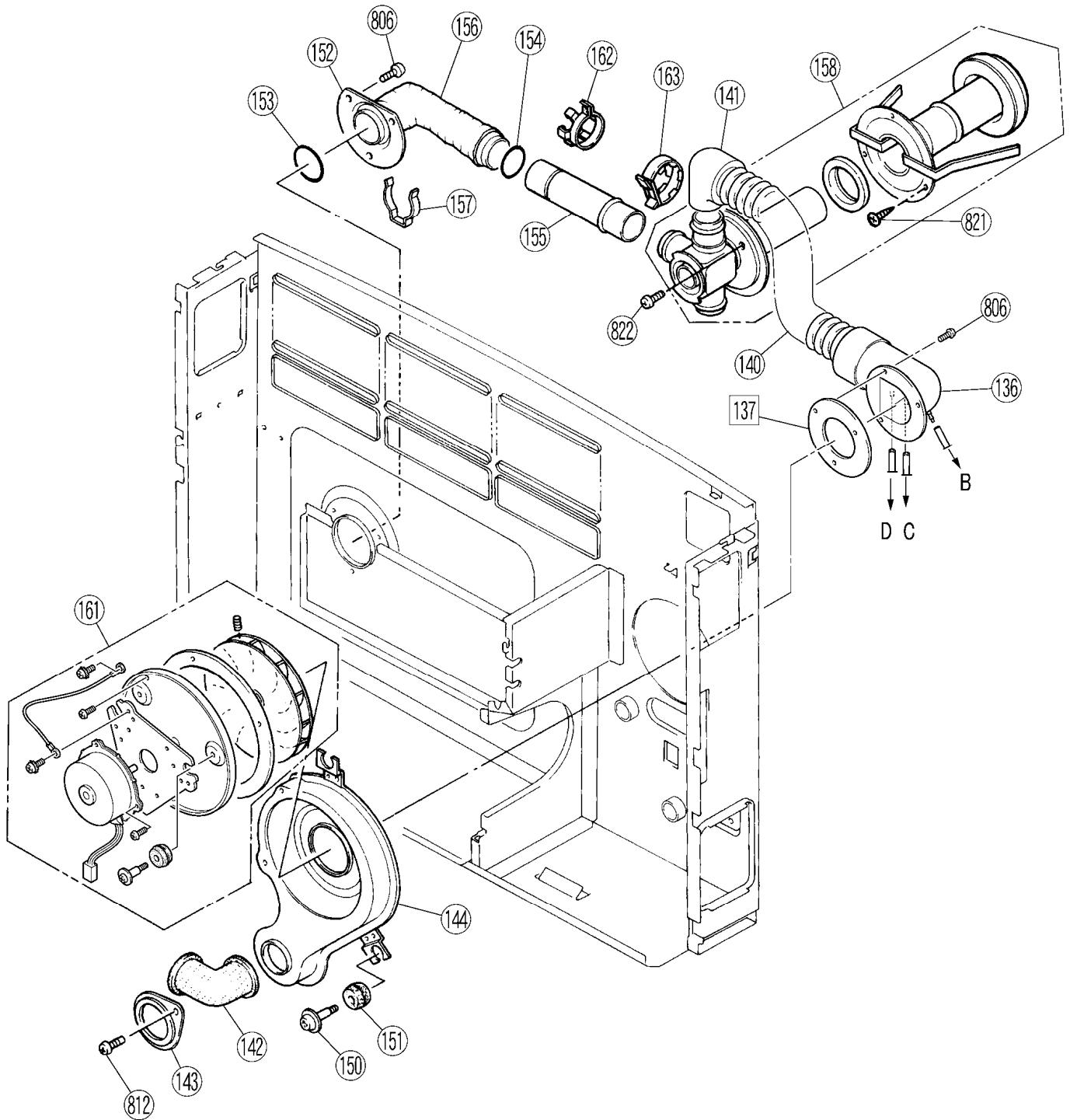

Parts List

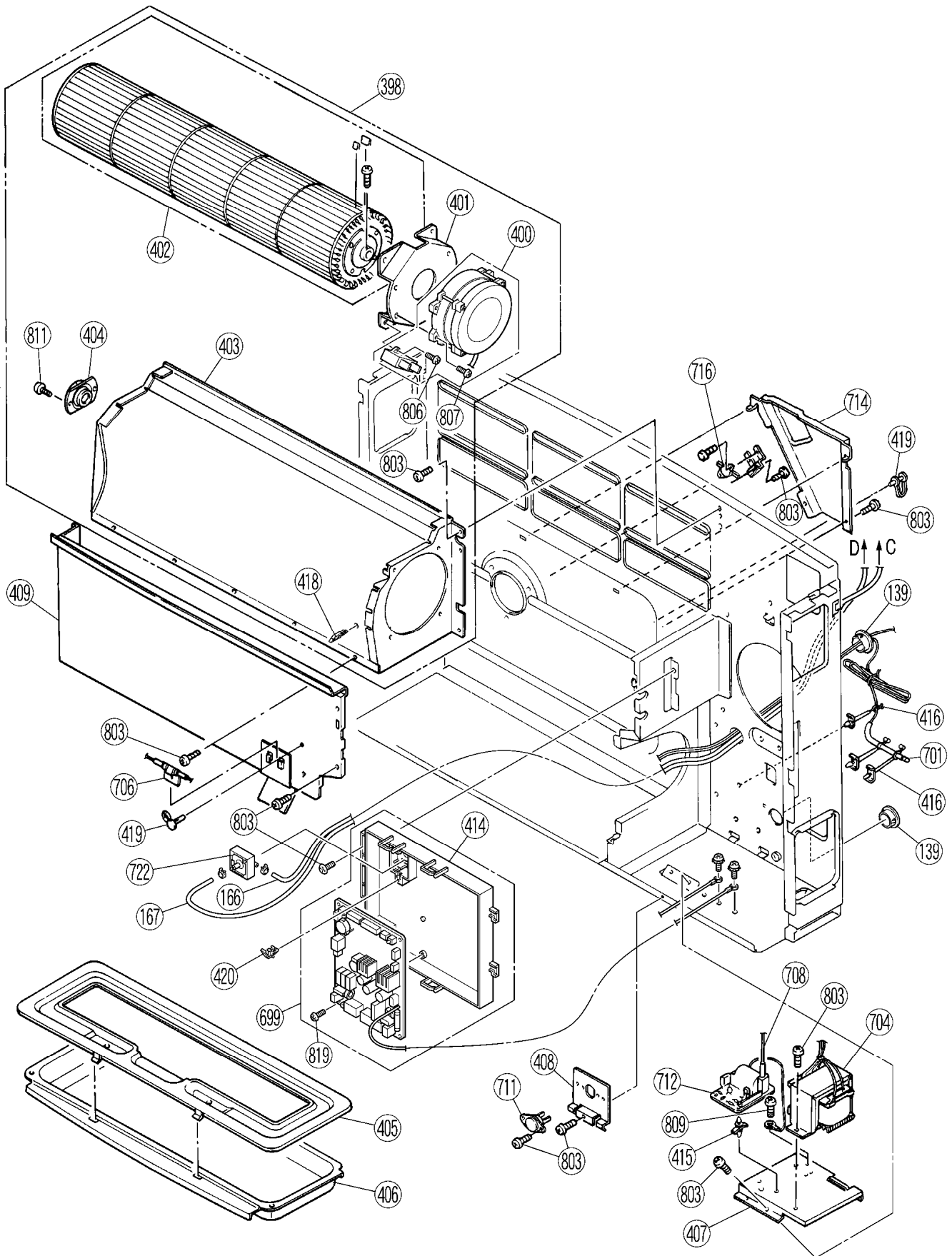

Parts List

For replacement parts call Rinnai at 1-800-621-9419.

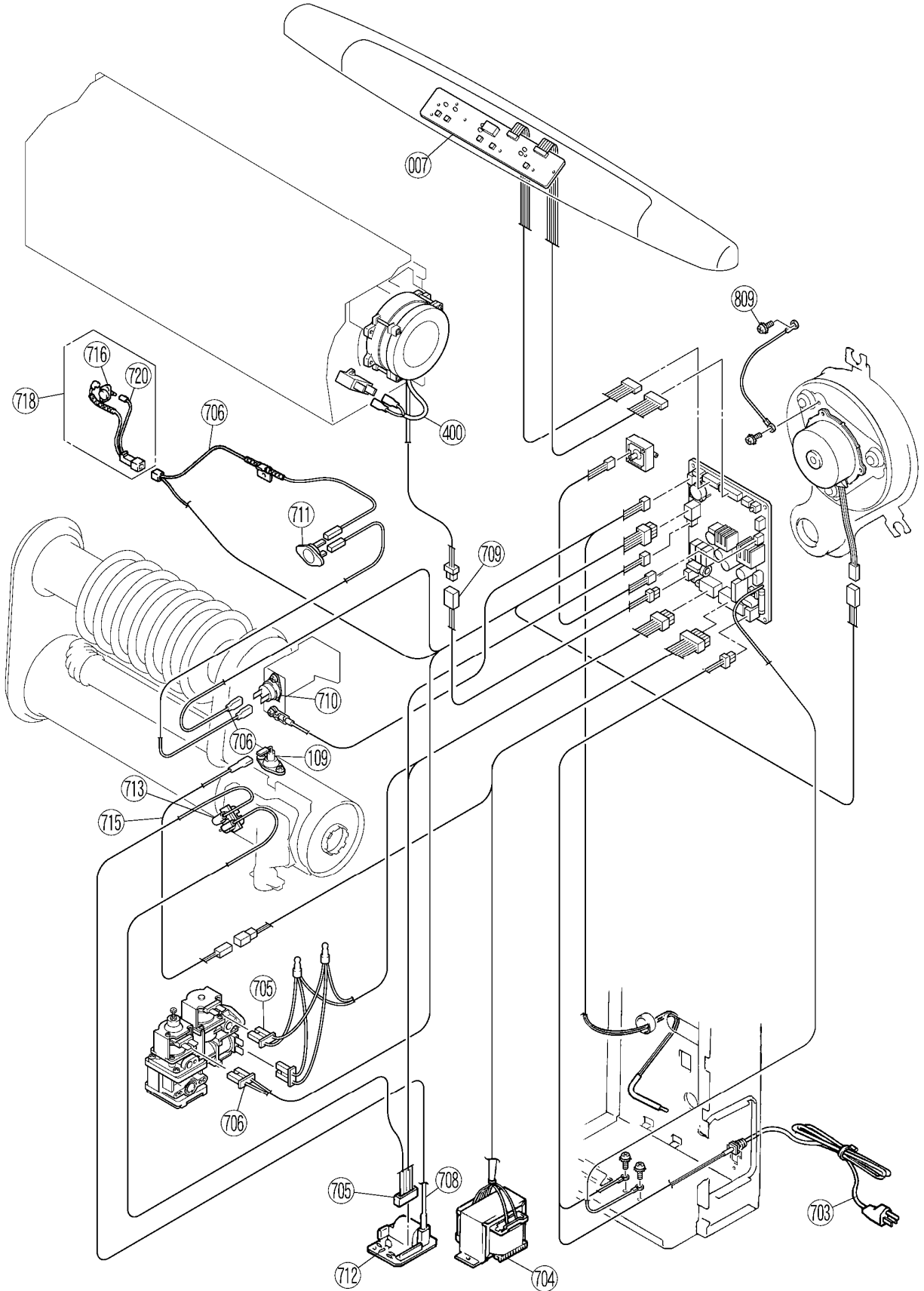

Parts List

ITEM	PART NUMBER	PART NAME	QTY	QTY	REMARKS
			558RFA	433RFA	
001	REAR PANEL ASS'Y	556F-311-9	1	1	
002	TOP PLATE SUPPORTER	556F-480	1	1	
003	TOP PLATE	556F-469-2	1	1	
004	DECORATING FRONT PANEL	556F-467-2	1	1	
005	DECORATING FRONT PANEL(R)	556F-475-2	1	1	
006	DECORATING FRONT PANEL(L)	556F-476B-10	1		
006	DECORATING FRONT PANEL(L)	556F-476B-11		1	
007	CONTROL P.C.B ASS'Y	556F-2079	1	1	
008	SIDE PANEL(R)	556F-456-2-B	1	1	
009	SIDE PANEL(L)	556F-456-1-B	1	1	
010	AIR FILTER SUPPORTER	556F-312	1	1	
011	AIR FILTER SUPPORTER(SIDE)	556F-313	2	2	
012	AIR FILTER ASS'Y	556F-462-2	1	1	
013	SUPPORT BOARD TO FAN	556F-314	1	1	
014	LATCH	CP-90380	2	2	
015	LEG	556F-464	2	2	
018	HEAT EXCHANGER PACKING	554F-421-2	1	1	
019	LOUVER ASS'Y	556F-472-2	1	1	
020	STRIKE	CP-90379	2	2	
021	FRONT PANEL	556F-470-3	1	1	
022	UNDER COVER ASS'Y	556F-473-2	1	1	
023	HEAT SHIELD PANEL	556F-321	1	1	
024	BACK SPACER TOP	556F-457-9	1	1	
025	BACK SPACER (R)	556F-1007-1	1	1	
026	BACK SPACER (L)	431F-1330-1	1	1	
027	WARM AIR SEAL PANEL	556F-305	1	1	
028	WALL BRACKET	304F-9077	1	1	
029	SPACER BRACKET	RHF300-152	1	1	
030	OPERATION BOX LID	556F-471	1	1	
031	LEG FIXING BOARD	550F-0220	2	2	
032	RUBBER LEG	550F-0225	2	2	
033	CORD PACKING B	AU131-236-B	3	3	
034	CORD PACKING A	AU131-236-A	2	2	
035	HEAT INSULATOR A	556F-477	1	1	
036	HEAT INSULATOR B	556F-478	1	1	
037	REAR PANEL PACKING	556F-325	1	1	
038	UNDER COVER TOTAL ASS'Y	556F-479-2	1	1	
090	ON-OFF VALVE ASS'Y	BRR37-244	1	1	
091	INLET CAP	3022-0363	1	1	
100	HEAT EXCHANGER ASS'Y	R558F-1001	1	1	
101	FIXING PLATE	556F-214	1	1	
102	COMBUSTION CHAMBER FIXER	556F-215	1	1	
103	OHS FIXER	556F-216	1	1	
105	BURNER BOX ASS'Y	557F-201-2	1	1	
106	FLANGE BOARD	R558F-1016	2	2	

Parts List

ITEM	PART NUMBER	PART NAME	QTY		REMARKS
			558RFA	433RFA	
107	SEAL PLATE B	557F-135	2	2	
108	ELECTRODE PLATE	RHF250-038	1	1	
109	FLAME ROD	1001F-104-2	1	1	
110	FLAME ROD PACKING	554F-148	1	1	
111	BURNER ASS'Y	B3A2-4	(4)	(4)	
112	SEAL PLATE PACKING	556F-2031	1	1	
113	BURNER BOX SUPPORTER ASS'Y	556F-225-3	1	1	
114	BURNER BOX PACKING	556F-211	1	1	
115	BURNER BOX FITTING PLATE SET	R558F-1011-SP	1	1	Includes 118, 121, 122, 123, 124, 713, 802, 804
116	DAMPER	556F-209-7	1	1	
117	SECONDARY AIR DAMPER	557F-208-1	1	1	
118	FITTING PLATE PACKING	R558F-1017	1	1	
119	MANIFOLD	556F-202-2	1	1	
120	INJECTOR	AU129-210-0.85	4	4	LPG
120	INJECTOR	AU129-210-1.25	4	4	NG
121	MANIFOLD PACKING	556F-203-2	1	1	
122	ELECTRODE MOUNTING PLATE	554F-114	1	1	
123	ERECTRODE	556F-510	1	1	
124	ERECTRODE PACKING	554F-147	1	1	
125	GAS CONTROL TOTAL ASS'Y A	556F-2098-1	1		
125	GAS CONTROL TOTAL ASS'Y A	556F-2098-2		1	
128	INTER CONNECTION ASS'Y	R431F-1150	1	1	
129	O RING	M10B-1-14	2	2	
130	BRIND SCREW	AU39-965	2	2	
131	O RING	M10B-13-14	1	1	
132	PACKING	C3I1-7	1	1	
133	GAS FILTER	RCK-6808	1	1	
134	GAS INLET	431F-1110	1	1	
135	OUTLET D	554F-220-4	1	1	
136	AIR INLET	556F-2084	1	1	
137	AIR INLET PACKING	RHF300F-79	1	1	
138	DRAIN PAN ASS'Y	556F-154	1	1	
139	BUSHING	CP-90326	2	2	
140	AIR INTAKE HOSE	RHF1000-130-D	1	1	
141	AIR INLET ELBOW	RHF1000-132	1	1	
142	CONNECTING TUBE	556F-404	1	1	
143	CONNECTING TUBE FIXER	556F-408	1	1	
144	COMBUSTION FAN CASING ASS'Y	556F-414-3	1	1	
150	SCREW FOR MOTOR	CP-30310	6	6	
151	CUSHION RUBBER	308F-8273	6	6	
152	FLUE SLIDING TUBE ASS'Y	R558F-1019	1	1	
153	O RING E	RHF300-200-E	1	1	
154	O RING D	FOT-001-016-3	1	1	
155	SLIDING TUBE	RHF250-148-2	1	1	

Parts List

ITEM	PART NUMBER	PART NAME	QTY 558RFA	QTY 433RFA	REMARKS
156	COVER	302F-1103	1	1	
157	RING	302F-1206	1	1	
158	VENT ASS'Y	431F-1900	1	1	
159	BACK PRESSURE PIPE ASS'Y	556F-417	1	1	
160	O RING	M10B-1-4	1	1	
161	COMBUSTION FAN MOTOR ASS'Y	556F-2095-SP	1	1	
162	PIPE STOPPER F	305F-0013	1	1	
163	PIPE STOPPER C	305F-0017	1	1	
164	POWER SUPPLY CORD BRACKET	RC-329-1033	1	1	
165	TUBE D	556F-415-4	1	1	
166	TUBE A(CLEAR)	1004F-2052-1	1	1	
167	TUBE B(BLACK)	1004F-2052-2	1	1	
171	CONNECTING TUBE FIXER	R558F-1018	1	1	
398	CONVECTION FAN TOTAL ASS'Y	556F-2082	1	1	
400	CONVECTION MOTOR	556F-2083	1	1	
401	MOTOR BASE	556F-256	1	1	
402	CONVECTION FAN	556F-258-2	1	1	
403	CONVECTION FAN CASING B	556F-257-2B	1	1	
404	BEARING	RC-223-74	1	1	
405	HUMIDIFIER TRAY LID	556F-310	1	1	
406	HUMIDIFIER TRAY	556F-309	1	1	
407	IGNITER FIXER	556F-412	1	1	
408	OHS FITTING PLATE	556F-522	1	1	
409	HEAT SHIELD BOARD ASS'Y	R558F-1057	1	1	
414	P.C.B FITTING PLATE	556F-2077	1	1	
415	CIRCUIT BOARD SPACER	CP-90436-3	4	4	
416	CABLE CLIP	CP-90125-2	3	3	
418	WIRE CLIP	CP-90107-2	3	3	
419	CLAMP	CP-90077-3	5	5	
420	CLAMP	CP-90618	1	1	
421	BACK SPACER (R) FIXER	556F-1030	1	1	
699	P.C.BOARD TOTAL ASS'Y	556F-2099-1	1		
699	P.C.BOARD TOTAL ASS'Y	556F-2099-2		1	
701	THERMISTOR HARNESS	556F-2088	1	1	
703	POWER SUPPLY CORD	CP-90466-2	1	1	
704	TRANSFORMER	ET-258	1	1	
705	SV · IG HARNESS	556F-2080	1	1	
706	MOTOR HARNESS	556F-2081	1	1	
708	HIGH TENSION CORD	431F-1460	1	1	
709	CONVECTION MOTOR HARNESS	R558F-1029	1	1	
710	OVERHEAT SWITCH	ES-01171	1	1	
711	OVERHEAT SWITCH	ES-01189	1	1	
712	IGNITER	EI-161	1	1	
713	SLEEVE	3022-0344	1	1	

Parts List

ITEM	PART NUMBER	PART NAME	QTY	QTY	REMARKS
			558RFA	433RFA	
714	TF COVER	556F-524	1	1	
715	FR LEAD	431F-1430	1	1	
716	OVERHEAT SWITCH	ES-01174	1	1	
718	OHS3 HARNESS ASS'Y	R558F-1030	1	1	
720	OHS3 HARNESS	R558F-1031	1	1	
722	PRESSURE SENSOR	1004F-2051	1	1	
801	SCREW	ZAA0420SZ			
802	SCREW	ZEAB0408UK			
803	SCREW	ZEAB0408SZ			
804	SCREW	ZEDB0412SZ			
805	SCREW	ZEAB0410SZ			
806	SCREW	ZEDB0408SZ			
807	SCREW	ZEDB0416SZ			
808	SCREW	ZHAE0306SZ			
809	SCREW	CP-30421-1			
810	SCREW	ZDAA0410SZ			
811	SCREW	ZEAB0406SZ			
812	SCREW	ZEDB0410SZ			
813	SCREW	ZEAB0408SC			
814	SCREW	ZDAA2.608SN			
815	SCREW	ZAA0422SZ			
816	SCREW	ZBA0410SZ			
817	SCREW	ZHAA0406SZ			
818	SCREW	ZEDB0408SC			
819	SCREW	ZGAA0406SZ			
820	SCREW	ZEAB0414SZ			
821	SCREW	CP-30408			
822	SCREW	ZBB0410SC			
823	SCREW	ZAA0408SZ			
824	SCREW	ZHAA0410SZ			
904	OPERATION LABEL	556F-2089	1	1	
905	FILTER LABEL	1001F-1651	1	1	
906	CAUTION LABEL	431F-1830	1	1	
907	CAUTION LABEL D	1001F-1652	1	1	
908	CAUTION LABEL	1001F-1656	1	1	
909	PROPANE STICKER	431F-1840	1	1	
909	NG STICKER	431F-1841	1	1	
910	EXHAUST CAUTION LABEL	1001F-1654	1	1	

Consumer Support

Warranty Information

The installer is responsible for your heater's correct installation.

Please complete the information below to keep for your records:

Purchased from: _____

Address: _____ Phone: _____

Date of Purchase: _____

Model No.: _____

Serial No.: _____

Installed by: _____ Installer's License No.: _____

Address: _____ Phone: _____

Date of Installation: _____

Limited Warranty

Gas Direct Vent Wall Furnace

What is covered?

This Warranty covers any defects in materials or workmanship, subject to the terms stated below. This Warranty extends to the original purchaser and subsequent transferees, but only while the product remains at the site of the original installation. This Warranty only extends through the first installation of the product and terminates if the product is moved or reinstalled at a new location.

How long does coverage last?

Item	Period of Coverage
Heat Exchanger	10 years from date of purchase *
All Other Parts	5 years from date of purchase
Reasonable Labor	2 years from date of purchase

What will Rinnai do?

Rinnai will repair or replace the covered product or any part or component that is defective in materials or workmanship as set forth. Rinnai will pay reasonable labor charges associated with the repair or replacement of any such part or component. All repair parts must be genuine Rinnai parts. All repairs or replacements must be performed by an individual or servicing company that is properly trained, state qualified or licensed to do the type of repair.

Limited Warranty - continued

Replacement of the product may be authorized by Rinnai only. Rinnai does not authorize any person or company to assume for it any obligation or liability in connection with the replacement of the product. If Rinnai determines that repair of a product is not possible, Rinnai will replace the product with a comparable product at Rinnai's discretion. If a component or product returned to Rinnai is found to be free of defects in material or workmanship, or damaged by improper installation or damaged during return shipping, the warranty claim for product, parts and labor may be denied.

- * If the Heat Exchanger fails due to a defect in material or workmanship within the sixth (6) through the tenth (10) year from the date of purchase, Rinnai will make the following allowances toward the purchase of a replacement Heat Exchanger:

Heat Exchanger	
Year of Failure	Allowance
6	50%
7	40%
8	30%
9	20%
10	10%

How do I get service?

You must contact a state qualified/licensed contractor or authorized service provider for the repair of a product under this Warranty. For the name of a qualified/authorized service provider please contact your place of purchase, visit the Rinnai website (www.rinnai.us), call Rinnai at 1-800-621-9419 or write to Rinnai at 103 International Drive, Peachtree City, Georgia 30269.

Proof of purchase is required to obtain warranty service. You may show proof of purchase with a dated sales receipt, or by registering within 30 days of purchasing the product. To register your appliance, please visit www.rinnairegistration.com. For those without internet access, please call 1-866-RINNAI1 (745-6241). Receipt of Registration by Rinnai will constitute proof-of-purchase for this product. However, Registration is not necessary in order to validate this Warranty.

What is not covered?

This Warranty does not cover any failures or operating difficulties due to the following:

- accident, abuse, or misuse
- alteration
- misapplication
- force majeure
- improper installation (such as but not limited to, condensate damage, improper venting, incorrect gas type, or incorrect gas pressure)
- improper conversion (including conversions for inventory adjustment)
- improper maintenance (such as but not limited to vent blockage)
- incorrect sizing
- any other causes other than defects in materials or workmanship

This Warranty does not apply to any product whose serial number or manufacture date has been defaced.

Limitation on warranties

No one is authorized to make any other warranties on behalf of Rinnai America Corporation. Except as expressly provided herein, there are no other warranties, expressed or implied, including, but not limited to warranties of merchantability or fitness for a particular purpose, which extend beyond the description of the warranty herein and further Rinnai shall not be liable for indirect, incidental, special, consequential or other similar damages that may arise, including lost profits, damage to person or property, loss of use, inconvenience, or liability arising from improper installation, service or use. Some states do not allow the exclusion or limitation of incidental or consequential damages, so the above limitation may not apply to you.

Any implied warranties of merchantability and fitness arising under state law are limited in duration to the period of coverage provided by this limited Warranty, unless the period provided by state law is less. Some states do not allow limitations on how long an implied Warranty lasts, so the above limitation may not apply to you.

This Warranty gives you specific legal rights, and you may also have other rights which vary from state to state.

NOTES

Ask about **Rinnai**

Rinnai's other fine products

Rinnai America Corporation
103 International Drive
Peachtree City, GA 30269
TOLL FREE: 1-800-621-9419
www.rinnai.us



Tankless Water Heaters

- Residential and Commercial Applications
- Continuous Hot Water
- Up to 9.8 GPM
- High Energy Efficiency
- Propane or Natural Gas
- Internal or External Installation
- Digital Temperature Control
- Small, Compact Design



Direct Vent Furnaces

- High Efficiency
- Cool-to-the-touch Cabinet
- Blower Included
- Vent Terminal A Included
- Gas Conversion Kit Included



Direct-Vent Fireplace, RHFE-750ETR

- Up to 83% AFUE Energy Efficiency
- Zero-Clearance Installation
- Available in Four Options of Fronts
- Remotes and Fan Included
- Gas Conversion Kit Available



Hydronic Air Handler

- Designed for Use with Rinnai Systems
- Domestic Hot Water Priority
- Optional Programmable Thermostat
- Zero Clearance to Combustibles
- Accommodates Standard Cased-Coils

Register your product at www.rinnairegistration.com
or call 1-866-RINNAI1 (746-6241)