

ITEM DESCRIPTION	SIZE NTH 80	SIZE NTH 105	SIZE NTH 150	SIZE NTH 210	SIZE NTH 285	SIZE NTH 399	SIZE NTH 500	SIZE NTH 600	SIZE NTH 750	SIZE NTH 850
69A Gasket Set (burner, ignitor, sensor & door gaskets)	RS2109100	RS2109100	RS2109100	RS2109100	RS2109100	RS2109100	RS2109100	RS2109100	RS2109100	RS2109100
70 Front Refractory Tile	RT2109000	RT2109000	RT2109000	RT2109000	RT2109000	RT2109000	RT2109000	RT2109000	RT2109000	RT2109000
71 Rear Refractory Tile	R50D2021	R50D2021	R50D2021	R50D2021	R50D2021	R50D2021	R50D2021	R50D2021	R50D2021	R50D2021
72 Main Burner w/gasket	R2069101	R2069102	R2069103	R2069104	R2069105	R2069106	R2069106	R2069107	R2069108	R2069109
73 Flame Sensor w/gasket	R2069200	R2069200	R2069200	R2069200	R2069200	R2069200	R2069200	R2069200	R2069200	R2069200
74 Ignitor w/gasket	R2069300	R2069300	R2069300	R2069300	R2069300	R2069300	R2069300	R2069300	R2069300	R2069300
74A Ignitor Gasket	RW2013300	RW2013300	RW2013300	RW2013300	RW2013300	RW2013300	RW2013300	RW2013300	RW2013300	RW2013300
74B Screw, Ignitor/ Flame Sensor	m4-.7X8mm S2112700	m4-.7X8mm S2112700	m4-.7X8mm S2112700	m4-.7X8mm S2112700	m4-.7X8mm S2112700	m4-.7X8mm S2112700	m4-.7X8mm S2112700	m4-.7X8mm S2112700	m4-.7X8mm S2112700	m4-.7X8mm S2112700
74C Flame/Sensor Gasket	RW2013400	RW2013400	RW2013400	RW2013400	RW2013400	RW2013400	RW2013400	RW2013400	RW2013400	RW2013400
75 Air/Gas Channel (80-600)	RS2108400	RS2108600	RS2108600	RS2108700	RS2108700	RS2108700	RS2108801	RS2108801	RS2115400	RS2115400
Air Adapter (750-850)										
75A Screw, Air/Gas Channel	RS2109400 (5)	RS2109400 (5)	RS2109400 (5)	RS2109400 (5)	RS2109400 (5)	RS2109400 (5)	RS2109400 (5)	RS2109400 (5)	RF2029200 (5)	RF2029200 (5)
76 Drain	R10-143	R10-143	R10-143	R10-143	R10-143	R10-143	R10-143	R10-143	R10-143	R10-143
77 Sight Glass	R50D2020	R50D2020	R50D2020	R50D2020	R50D2020	R50D2020	R50D2020	R50D2020	R50D2020	R50D2020
Electrical Components – See Figure 67										
80 Control Panel Enclosure	R50D7001	R50D7001	R50D7001	R50D7001	R50D7001	R50D7001	R50D7001	R50D7001	R50D7001	R50D7001
81 Transformer	RE2108700	RE2108700	RE2108700	RE2108700	RE2108700	RE2108700	RE2108700	RE2108700	RE2108700	RE2108700
82 High Voltage Shield	R50D7002	R50D7002	R50D7002	R50D7002	R50D7002	R50D7002	R50D7002	R50D7002	R50D7002	R50D7002
83 Top Panel Bracket	R50D7003	R50D7003	R50D7003	R50D7003	R50D7003	R50D7003	R50D7003	R50D7003	R50D7003	R50D7003
84 Electronic Control Module, Standard	Contact Customer Service at 800 900-9276 x11									
84 Electronic Control Module, CSD-1	Contact Customer Service at 800 900-9276 x11									
85 Rocker Switch	RE2322700	RE2322700	RE2322700	RE2322700	RE2322700	RE2322700	RE2322700	RE2322700	RE2322700	RE2322700
86 Control Display	RE2347200	RE2347200	RE2347200	RE2347200	RE2347200	RE2347200	RE2347200	RE2347200	RE2347200	RE2347200
87 Wire Harness	R50D7412	R50D7412	R50D7412	R50D7414	R50D7408	R50D7406	R50D7402	R50D7410	R50D7409	R50D7409
89 Air Pressure Switch	RE2334700	RE2334700	RE2334700	RE2334701	RE2334700	—	RE2334700	RE2334700	RE2334701	RE2334700
90 Water Flow Switch	—	—	—	—	—	R2008400	R2008400	R2008400	R2008400	R2008400

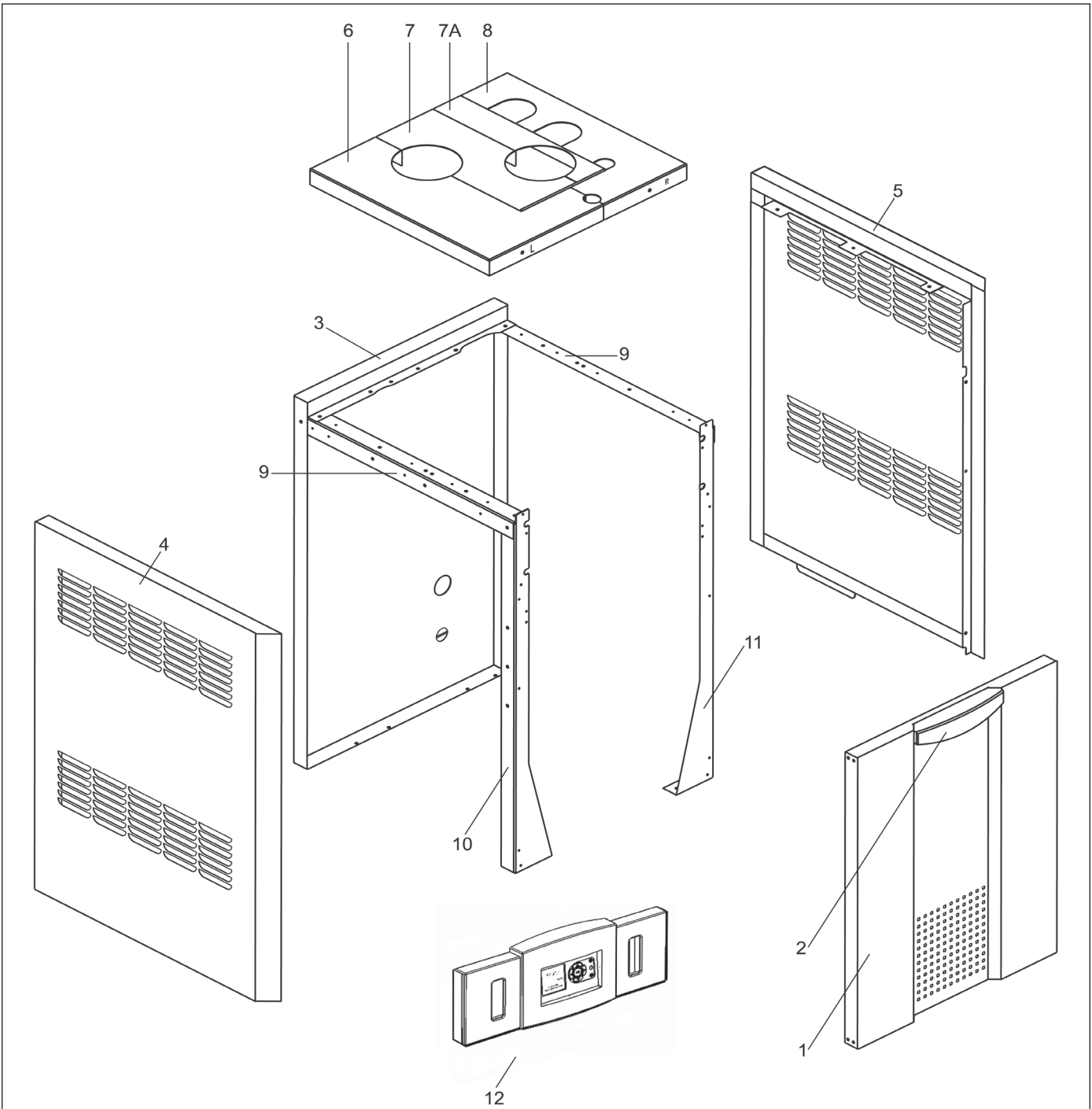
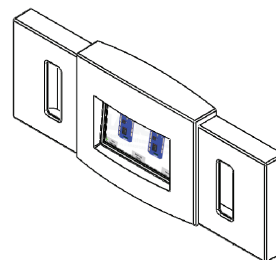

Figure 50 - Jacket Components



Optional Touchscreen User Interface Kit (KM50D7130)

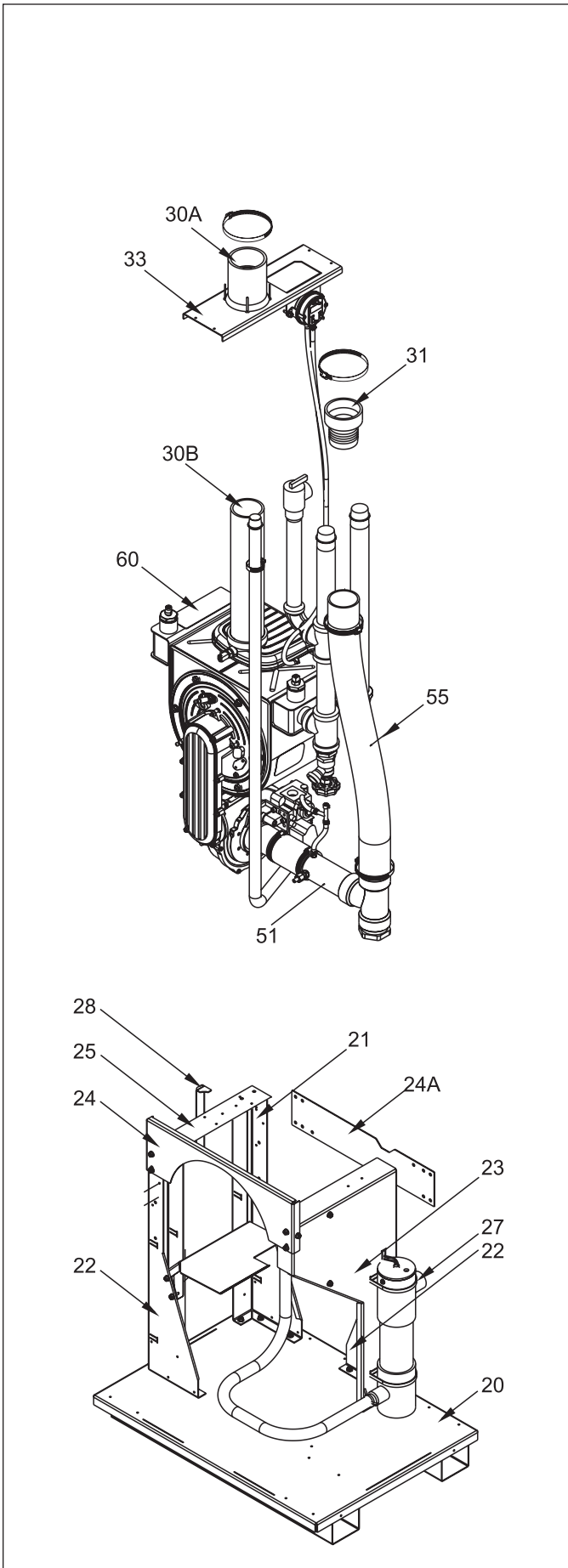

Figure 51a - Internal Components, Sizes 80-210

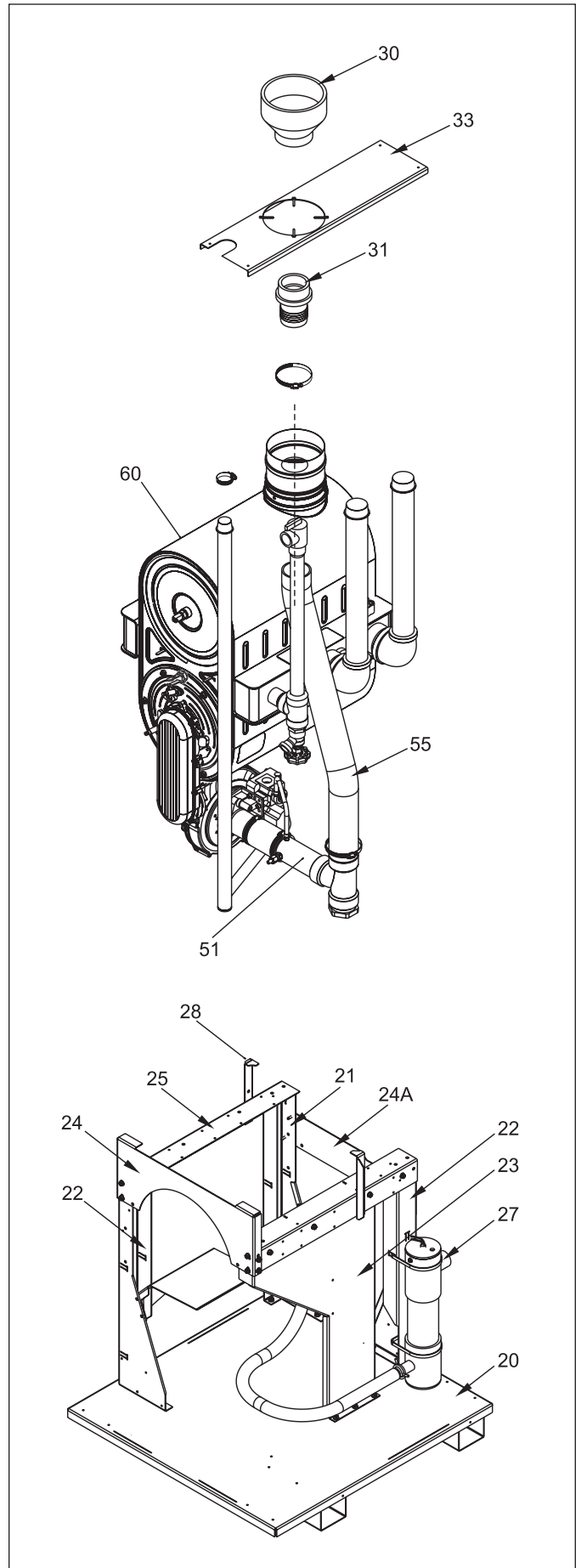

Figure 51b - Internal Components, Sizes 285-600

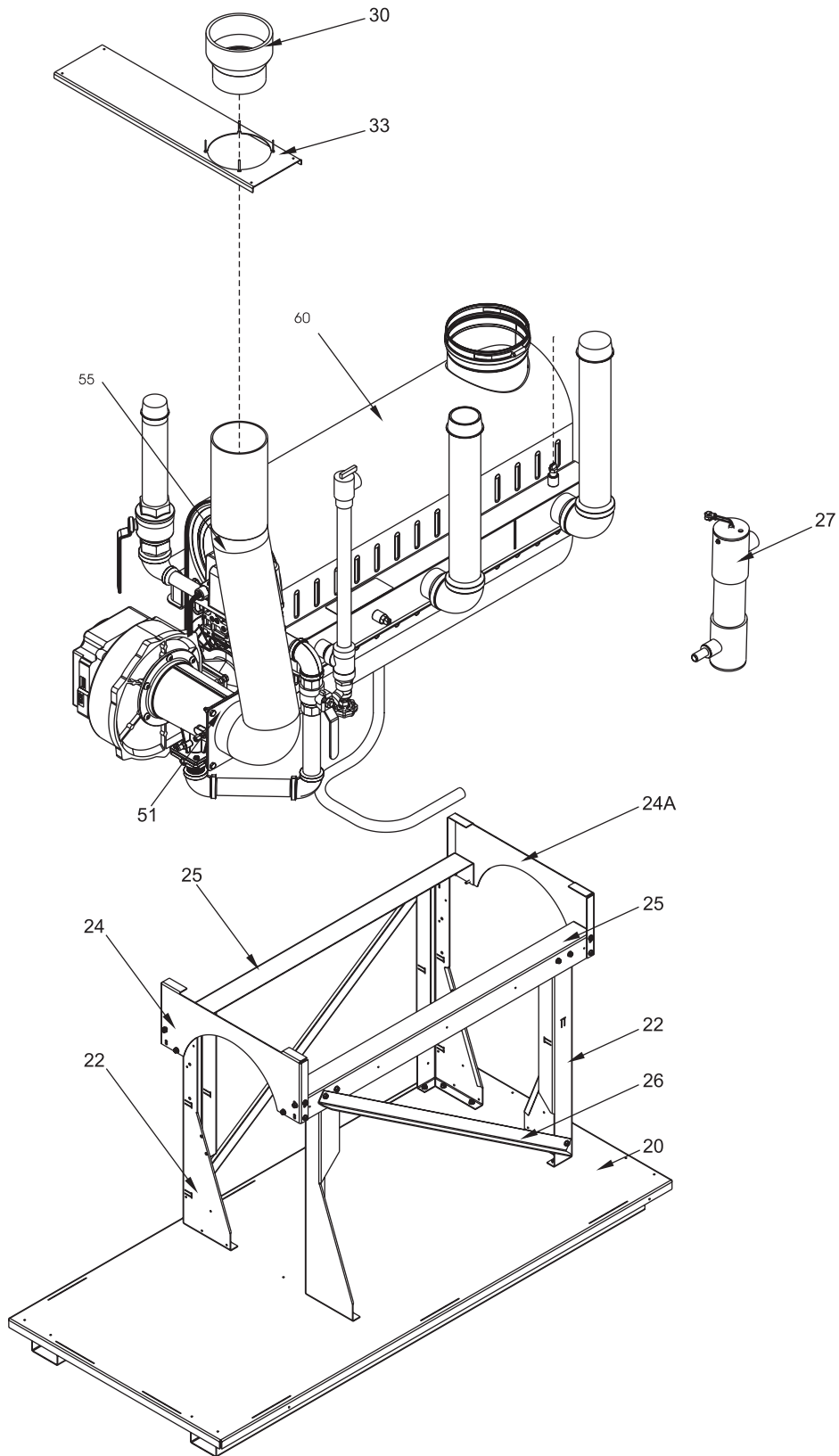

Figure 51c - Internal Components, Sizes 750-850

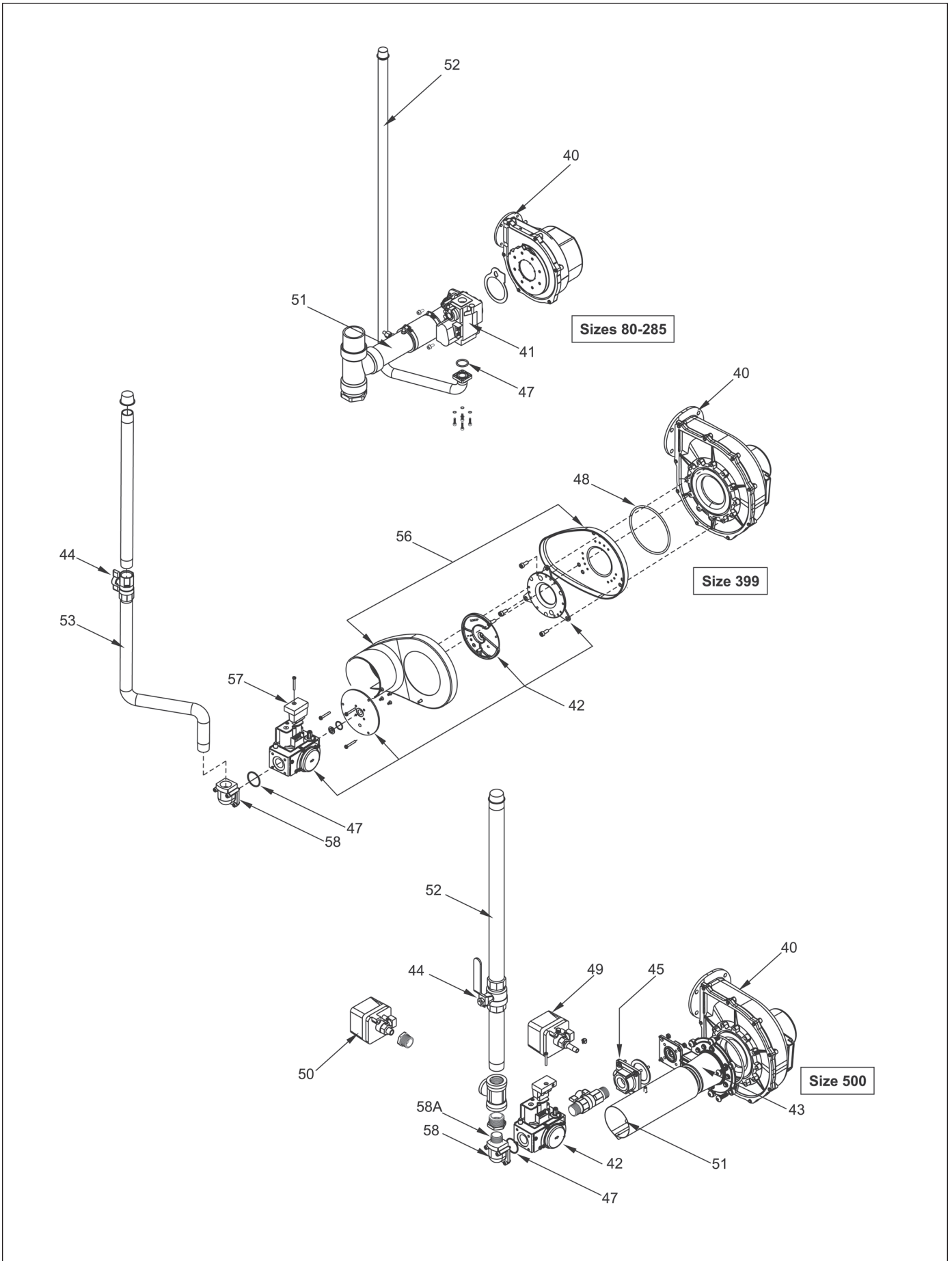

Figure 52a - Gas Train Components, Sizes 80-500

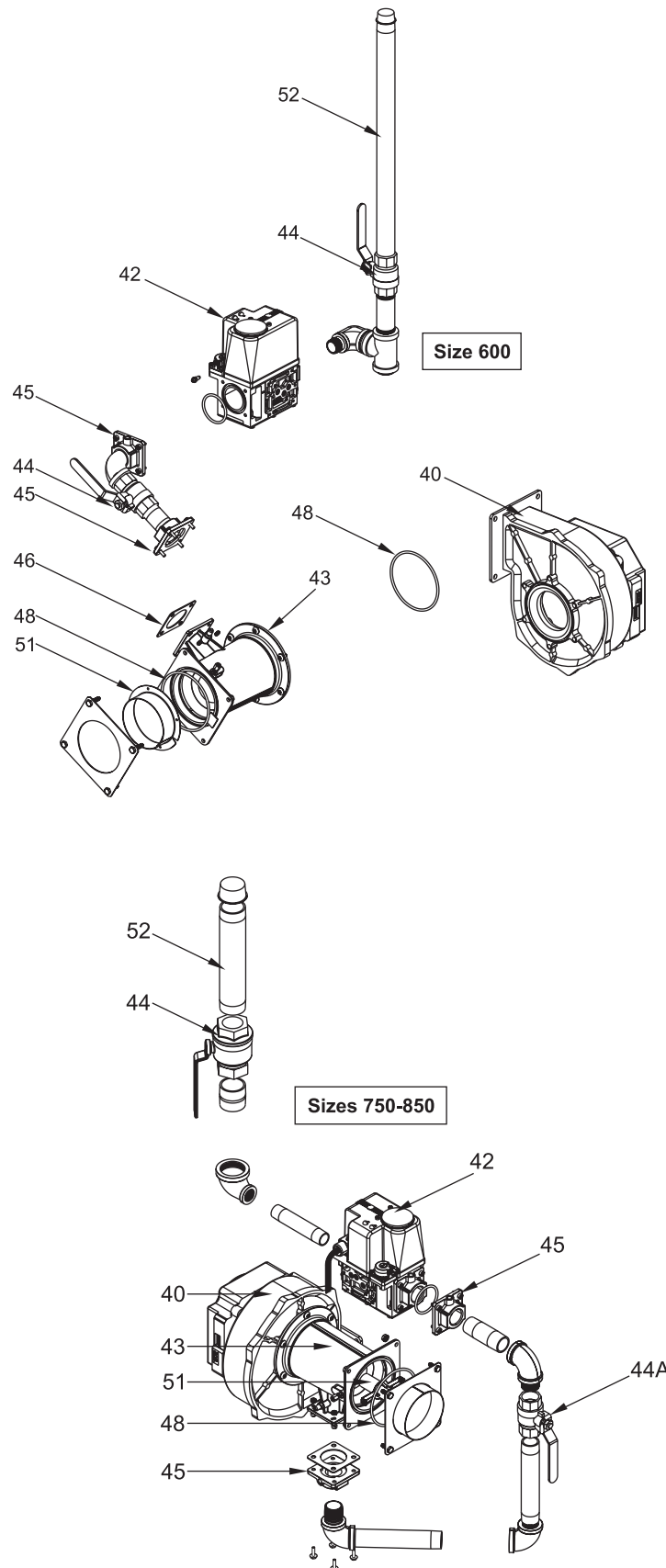

Figure 52b - Gas Train Components, Sizes 600-850

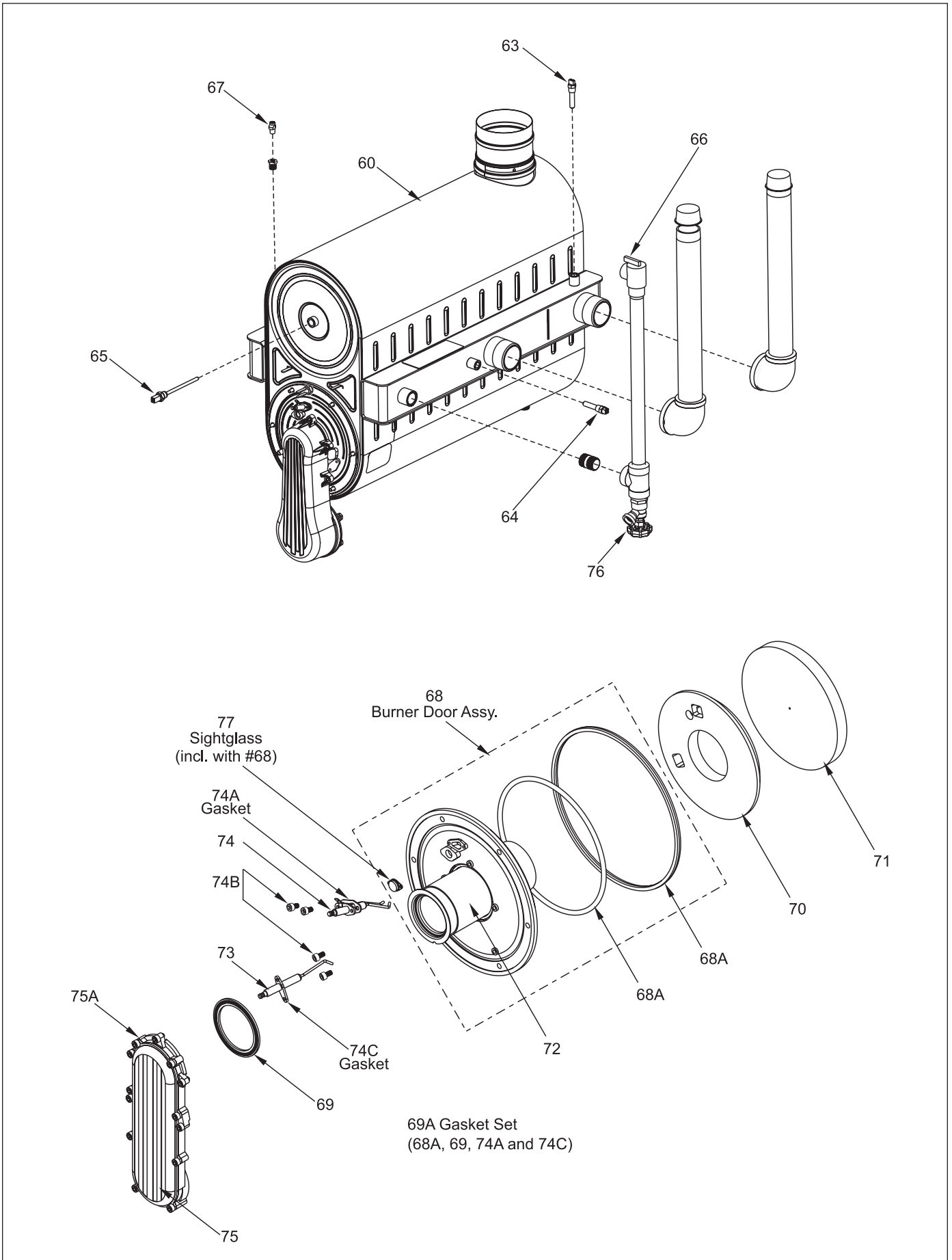

Figure 53 - Heat Exchanger Components

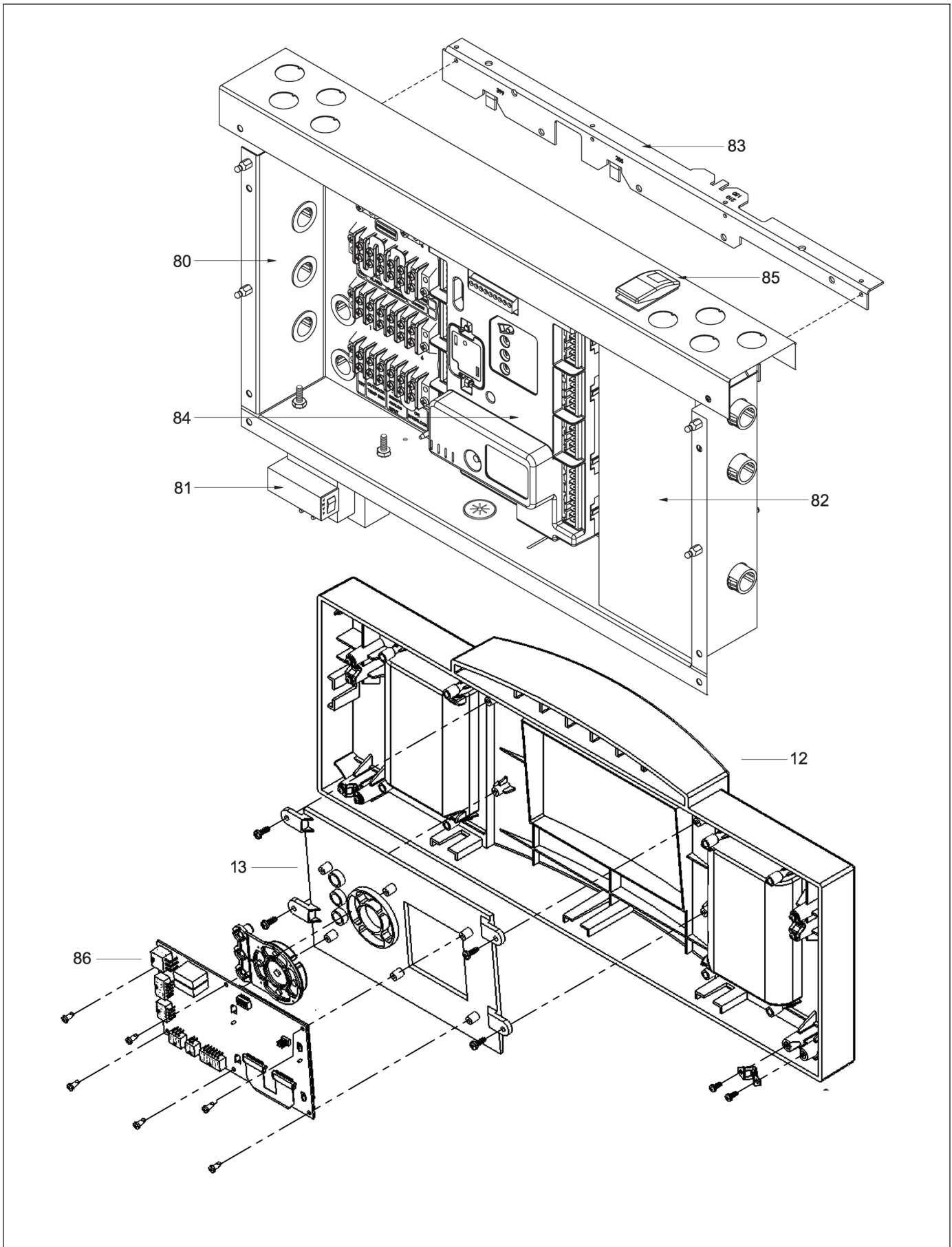

Figure 54 - Electrical Components