

# WVC<sup>TM</sup>

## Fuelsaver Series

Modern Coal or Wood Burning "Add-on" Boiler



**New Yorker**<sup>®</sup>  
RESIDENTIAL HEATING BOILERS

Fuelsaver is an excellent add-on to an existing boiler or addition to a new boiler. It operates on wood or coal and is designed to provide both hydronic heat and domestic hot water. The high mass wet leg design of the heat exchanger and optional integral domestic hot water coil provides efficient operation.

- **Available in 2 Sizes**
- **Heating Capacities from 90 to 130 MBH**

# Ratings & Specifications

Model	WC-90	WC-130
<b>Gross Output</b>	90,000 BTU/HR	130,000 BTU/HR
<b>Water Content</b>	17.9 Gallons	21.2 Gallons
<b>Heating Surface</b>	15.5 Sq. Ft.	18.8 Sq. Ft.
<b>Gross Weight</b>	640 lbs.	783 lbs.
<b>Stack Diameter</b>	6 inches	7 inches
<b>Energy Testing Lab of Maine (ETLM) Listing Number</b>	80-12-65	82-02-02
<b>State of Connecticut Board of Materials Review Listing #BMR</b>	058-80	058-80
<b>Wood Load Capacity</b>	60 lbs.	80 lbs.
<b>Wood Length</b>	18 inches	24 inches
<b>Coal Load</b>	40 lbs.	60 lbs.
<b>Coal Type</b>	Pea or Chestnut Anthracite	Pea or Chestnut Anthracite

Design working pressure 30 PSIG, water only.

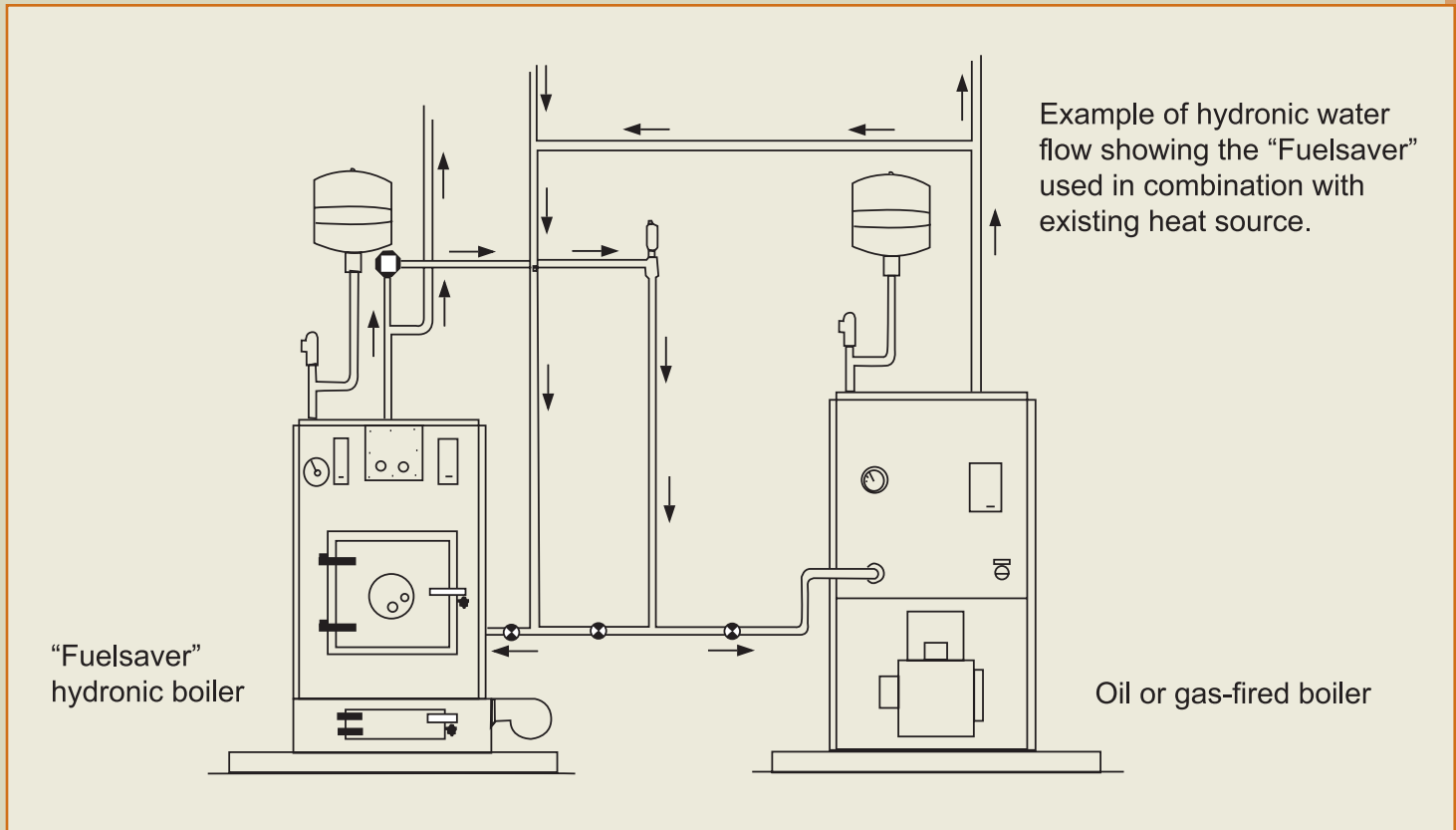

© 2006 New Yorker Boiler Company, Inc.  
 Hatfield, PA  
 (215) 855-8055  
 www.newyorkerboiler.com  
 PL81420081000-2/06-2.5Ms





