

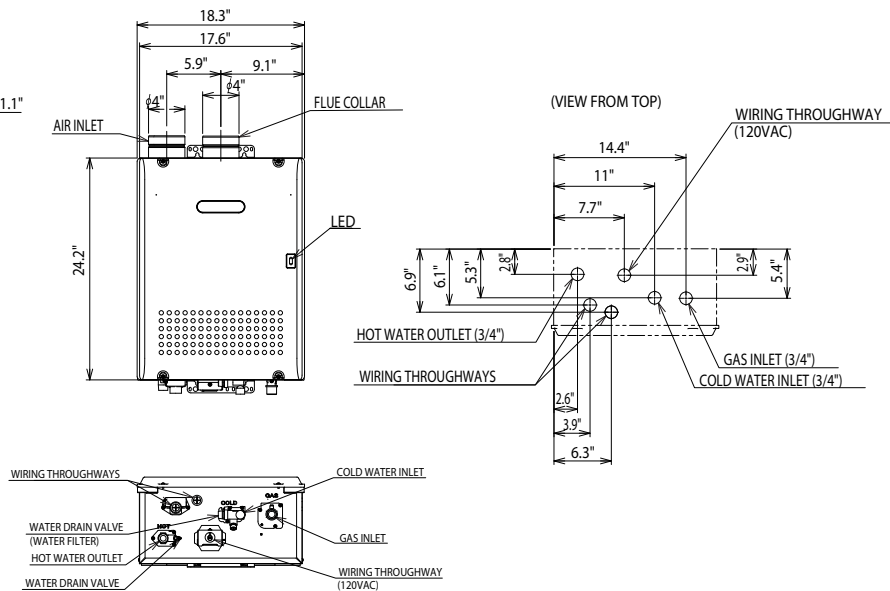

HEIGHT OF EACH FITTING  
FROM BOTTOM OF CASE

	N-0931M-DV
HOT WATER OUTLET	1.7"
COLD WATER INLET	2.2"
GAS INLET	2.2"

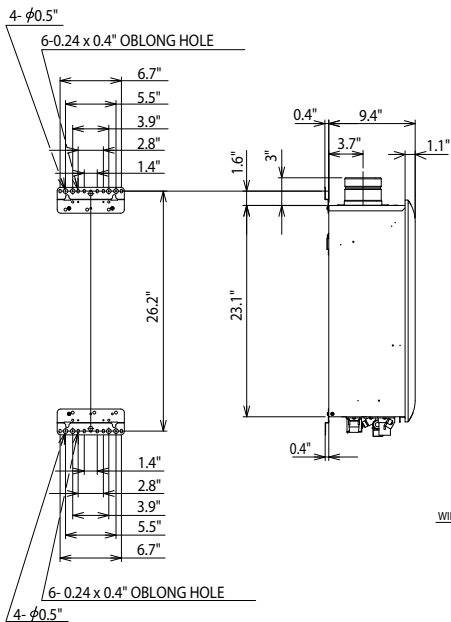
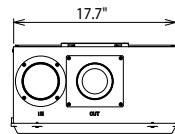

Item		Specification
Model Name		N-0931M-DV
Type	Installation	Indoor, Wall Hung
	Air Supply/Exhaust	Direct Vent (Sealed Combustion)
Ignition		Direct Ignition
Operating Water Pressure		15 - 150 PSI
Minimum Flow Rate		0.5 GPM
Gas Supply Pressure		NG : 5.0" - 10.5" LP : 10.5" - 14.0"
Dimensions		24.2"(Height) x 18.3"(Width) x 9.4"(Depth)
Weight		62 (pounds)
Water Holding Capacity		0.3 Gallon
Connection Sizes	Water Inlet	3/4"
	Hot Water Outlet	3/4"
	Gas Inlet	3/4"
Power	Supply	120VAC(60Hz)
	Consumption	NG: 115W LP: 120W Freeze Prevention 250W
Material	Casing	Zincified Steel Plate / Polyester Coating
	Flue Collar	Stainless Steel
	Heat Exchanger	Copper Sheeting, Copper Tubing
Safety Devices		Flame Rod, Thermal Fuse, Lightning Protection Device (ZNR), Overheat Prevention Device, Freezing Prevention Device, Fan Rotation Detector
Included Accessories		Remote Controller, Remote Controller Cord, Anchoring Screws
Optional Accessories		Isolation Valves (#IK-WV-5), Pipe Cover (#PC-3S), ScaleShield (#SS-HB-2), Quick-Connect Cable (#QC-1M), Multi-System Controller (SC-201-6M, -12M, -24M)

# Model N-0931M-DV Product Performance

## Flow Rates

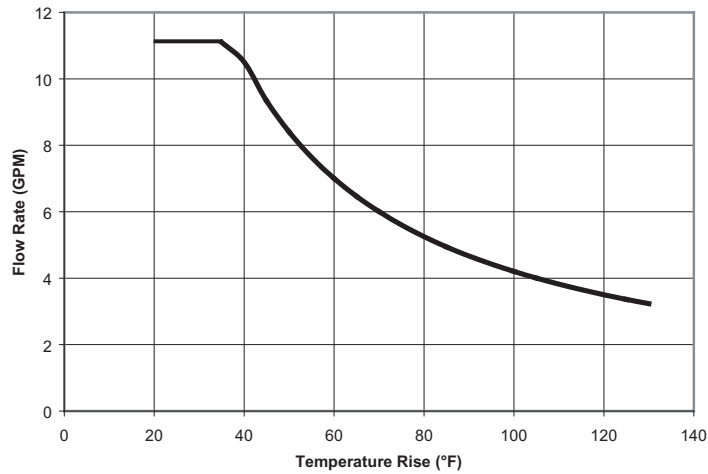

Temperature Rise (°F)	20	30	40	45	50	60	70	80	90	100	110	120	130
Flow Rate (GPM)	11.1	11.1	10.5	9.3	8.4	7.0	6.0	5.3	4.7	4.2	3.8	3.5	3.2

\*For peak flow rates in shaded areas, contact Noritz for proper setting.

## Pressure Loss

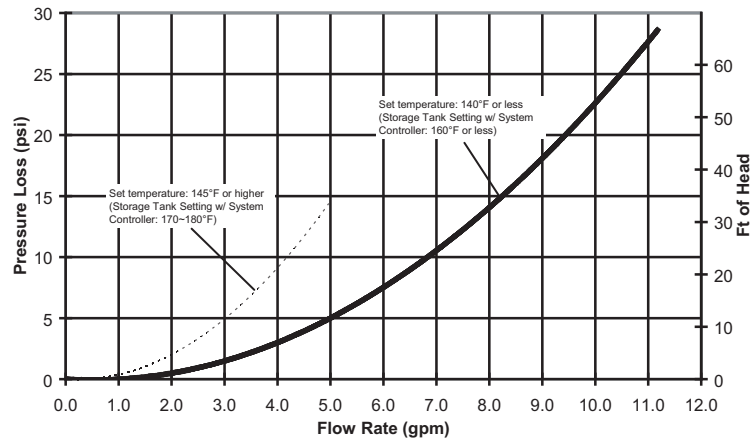

Item		Maximum Performance	Minimum Performance
Gas Consumption	NG	250,000 btuh	11,000 btuh
	LP	250,000 btuh	11,000 btuh
Thermal Efficiency		84%	
Hot Water Capacity	35°F Rise	11.1 Gal/min.	
	45°F Rise	9.3 Gal/min.	
	77°F Rise	5.5 Gal/min.	
	100°F Rise	4.2 Gal/min.	
Capacity Range		0.5 - 11.1 Gal/min.	
Temperature Settings		100-150°F (In 5°F intervals), 160, 170, 180°F (14 Options)	
Default Temperature Options		120, 130, 140, 180°F (Default is 120°F)	
Features		Quick-Connect (2 units), Multi-System (Up to 24 units), Pump Control, Temperature Lockout, High Elevation Adjustment	
Warranty		12/5- Residential, 3/5- Commercial or Circulation Use	
Approvals		CSA, UPC, NSF, Low NOx Approved By SCAQMD, Suitable for Installation in a Manufactured (Mobile) Home	

Noritz America reserves the right to discontinue, or change at any time, the designs and/or specifications of its products without notice.