

GWH 345/450 ESR



Temperature Modulated with Electronic Ignition
Suitable for heating recirculating potable water



BOSCH

ProTankless[™]



GWH-345/450-ESR-N - Natural Gas

GWH-345/450-ESR-L - Liquefied Petroleum (LP) Gas

Warning: If the information in this manual is not followed exactly, a fire or explosion may result causing property damage, personal injury or death. Do not store or use gasoline or other flammable vapor and liquids in the vicinity of this or any other appliance.

Improper installation, adjustment, alteration, service or maintenance can cause injury or property damage. Refer to this manual. For assistance or additional information consult a qualified installer, service agency or the gas supplier.

In the Commonwealth of Massachusetts this product must be installed by a licensed plumber or gas fitter.

Upon completion of the installation, these instructions should be handed to the user of the appliance for future reference.

What to do if you smell gas

- Close gas valve. Open windows and doors, and evacuate the building.
- Do not try to operate any appliance.
- Do not touch any electrical switch; do not use any phone in your building
- Immediately call your gas supplier from a neighbor's phone. Follow the gas supplier's instructions.
- If you cannot reach your gas supplier, call the fire department.
- Installation and service must be performed by a qualified installer, service agency or the gas supplier.



Index

1	Warning	2
2	Appliance details	4
2.1	Features	4
2.2	GWH-345/450-ESR Specifications (Technical data)	4
2.3	Unpacking the GWH-345/450-ESR heater	5
2.4	General rules to follow for safe operation	6
2.5	Dimensions and minimum installation clearances	7
2.6	Applications	8
2.7	Water quality	9
3	Installation instructions	10
3.1	Introduction	10
3.2	Proper location for installing your heater	10
3.3	Heater placement and clearances	10
3.4	Mounting installation	10
3.5	Combustion air requirements	11
3.6	Venting	13
3.6.1	Vent material and specifications	13
3.6.2	Vent connections and combustion air inlet restrictors	14
3.6.3	Condensate drain requirements	17
3.6.4	Room sealed installation (Twin pipe)	17
3.6.5	Vertical terminations	18
3.6.6	Horizontal terminations	18
3.6.7	Exhaust vent configuration examples	22
3.7	Gas piping & connections	23
3.8	Measuring gas pressure	25
3.9	Checking restrict. plate size by measuring CO ₂ level value	26
3.10	Water connections	26
3.11	Electrical connections	27
4	Operating instructions	28
4.1	Initial filling instructions	28
4.2	For your safety read before operating your water heater	28
4.3	Startup instructions	28
4.4	Power	29
4.5	Recirculating water temperature	29
4.6	Temperature and hot water flow	29
4.7	Freeze protection	29
4.8	Electrical diagram	30
5	Maintenance and service	31
5.1	Diagnostic mode	31
6	Altitude adjustments	33
7	Troubleshooting	34
8	GWH-345/450-ESR Functional scheme	36
9	Interior components diagram and parts list	37
9.1	Interior components	37
9.2	Components diagram	38
9.3	Parts list	39
10	Protecting the environment	40
11	Ten Year Limited Warranty	41

1 Warning

For your safety

Do not store or use gasoline or other flammable, combustible or corrosive vapors and liquids in the vicinity of this or any other appliance.



Warning: Carefully plan where you install the heater. Correct combustion air supply and flue pipe installation are very important. If a gas appliance is not installed correctly, fatal accidents can result from lack of air, carbon monoxide poisoning or fire.



Warning: Exhaust gas must be vented to outside using 3" single wall sealed stainless steel vent pipe suitable for category III vent systems and temperatures up to 480°F. Vent and combustion air connector piping must be sealed gas-tight to prevent possibility of flue gas spillage, carbon monoxide emissions and risk of fire, resulting in severe personal injury or death.



Warning: Place the recirculating water heater in a location where water leaks will NOT DAMAGE adjacent areas or lower floors.



Warning: Field wiring connections and electrical grounding must comply with local codes, or in the absence of local codes, with the latest edition of the National Electric Code, ANSI/NFPA 70, or in Canada, all electrical wiring must comply with the local codes and the Canadian Electrical Code, CSA C22.1 Part 1.



Warning: Shock hazard line voltage is present. Before servicing the recirculating water heater, turn off the electrical power to the recirculating water heater at the main disconnect or circuit breaker. Failure to do so could result in severe personal injury or death.



Warning: The recirculating water heater must be disconnected from the gas supply piping system during any pressure testing of that system at test pressures equal to or more than 0.5 psig (14" W.C.).



Warning: The recirculating water heater should be located in an area where leakage of the tank or connections will not result in damage to the area adjacent to the appliance or to lower floors of the structure. When such locations cannot be avoided, it is recommended that a suitable drain pan, adequately drained, be installed under the appliance. The pan must not restrict combustion air flow.



Warning: The maximum inlet gas pressure must not exceed the value specified by the manufacturer and that the minimum value listed is for the purposes of input adjustment.



Warning: If a water heater is installed in a closed water supply system, such as one having a backflow preventer in the cold water supply line, means shall be provided to control thermal expansion. Contact the water supplier or local plumbing inspector on how to control this situation.



Warning: Keeping appliance area clear and free from combustible materials, gasoline and other flammable vapors and liquids.



Warning: Not obstructing the flow of combustion and ventilation air.



Warning: When manually operating the relief valve, precautions must be taken prior to operating the relief valve to avoid contact with hot water coming out of the relief valve and to prevent water damage.



Caution: Label all wires prior to disconnection when servicing controls. Wiring errors can use improper and dangerous operation. Verify proper operation after servicing.



Warning: If a relief valve discharges periodically, this may be due to thermal expansion in a closed water supply system. Contact the water supplier or local plumbing inspector on how to correct this situation. Do not plug the relief valve.

FCC:

This device complies with Part 15 of the FCC rules. Operation is subject to the following two conditions: (1) This device may not cause harmful interference, and (2) this device must accept any interference received, including interference that may cause undesired operation.



Caution: Any changes or modifications not expressly approved by the party responsible for compliance could void the user's authority to operate the equipment.

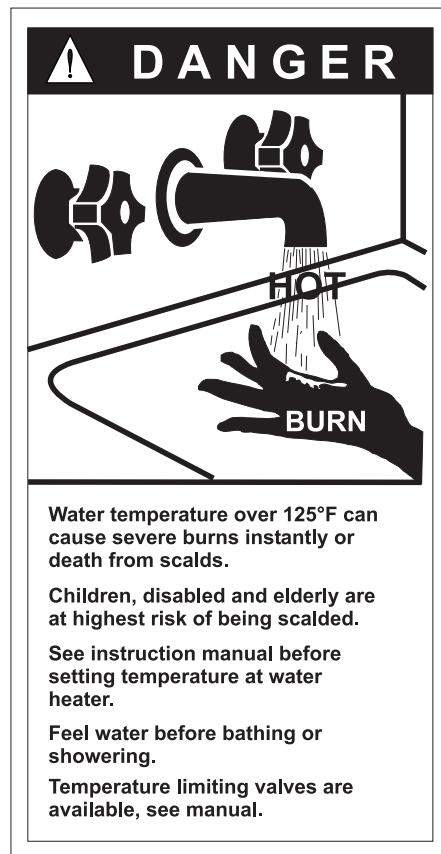

Fig. 1

2 Appliance details

2.1 Features

Parts

- Sealed combustion burner.

Safety

- Ionization flame sensor
- Over temperature protection.

High quality materials for long working life

- Copper heat exchanger
- Compact space saver: mounts on a wall with supplied bracket.

Features

- LCD screen to display temperatures, burner operation and error codes
- On/Off button and separate temperature controls for domestic water heating and recirculating water
- Reset button
- Failure codes for diagnostics and repair
- Freeze prevention cycle.



BOSCH is constantly improving its products, therefore specifications are subject to change without prior notice.

2.2 GWH-345/450-ESR Specifications (Technical data)

Approved in US/Canada

Capacity

GWH345 Maximum flow rate: 3.5 GPM (13 l/min) at a 45°F (25°C) rise.

GWH450 Maximum flow rate: 4.5 GPM (17 l/min) at a 45°F (25°C) rise.

Maximum output

GWH345 - 77,900 Btu/h (22.8 kW)

GWH450 - 98,400 Btu/h (28.8 kW)

Maximum input

GWH345 - 95,000 Btu/h (27.8 kW)

GWH450 - 120,000 Btu/h (35.1 kW)
(3 to 1 Modulation)

Efficiency in %

GWH345 Combustion efficiency: 82%

GWH450 Combustion efficiency: 81%

Min. Output

GWH345 - 23,900 Btu/h (7 kW)

GWH450 - 35,500 Btu/h (10.4 kW)

Temperature Control

Selection range: 113°F (45°C) - 194°F (90°C)

Gas Requirement

Gas connection (inches) - 3/4"

Inlet gas pressure under operation (with a high hot water flow rate)*

- Propane: 11" - 13" water column
- Natural Gas: 5.5" - 10.5" water column.

* To measure gas pressure, see Measuring Gas Pressure, chapter 3.8.

Venting

3" AL 29-4C single wall sealed stainless steel vent pipe.

See chapter 3.6 for Venting.

Water

- Hot water connection - 3/4" NPT
- Cold water connection - 3/4" NPT.

Combustion

- NO_x ≤ 100 ppm
- CO ≤ 250 ppm
- CO₂ level (see table 8 for correct restrictor dimension).

Dimensions

- Depth (in): 11 3/4" (300 mm)
- Width (in): 15 3/4" (400 mm)
- Height (in): 27 1/2" (700 mm)
- Weight: 47 pounds (21 kg).

Gas types

Natural Gas.

Liquid Propane.

The appliance is not field convertible.

Voltage

120 V AC (50/60 Hz)

Amperage

Idle - 40 mA

Operation - ≤ 1.5 A

Noise

≤ 50 db (A)

Safety devices

- Flame failure device (Ionization flame control)
- Overheat prevention (temperature limiter)
- Pressure switch (blocked vent protection).

Water resistant

IP X4 (protection against water drops)

2.3 Unpacking the GWH-345/450-ESR heater

This heater is packed securely.

The box includes:

- Wall-mounted gas fired recirculating water heater
- Bracket and screws for wall hanging the heater (Part No. 8708003143)
- Exhaust vent adaptor (with 4 screws and gasket provided) (Part No. 8705504149)
- Combustion air inlet adaptor (with 4 screws and gasket provided) (Part No. 8705504148)
- Installation manual
- Product registration card
- Energy Guide label
- Pressure relief valve (Part No. BP1000A150)
- **Inlet air restrictors**
 - GWH 345 ESR N: Ø38/40/42
 - GWH 345 ESR LP: Ø38/40/42
 - GWH 450 ESR N: Ø44/47/50/55
 - GWH 450 ESR LP: Ø47/50/55/60

Do not lose this manual. Please complete and return the enclosed product registration card.

Before installing the unit, be certain you have the correct heater for your type of Gas - Propane or Natural Gas. Identification labels are found on the shipping box, and on the rating plate which is located on the right side panel of the cover.

To remove front cover

The front cover is secured with two screws to prevent unauthorized access. Always secure the control panel and front cover with these screws.

- ▶ Loosen the two Philips head screws located as shown in fig. 2.

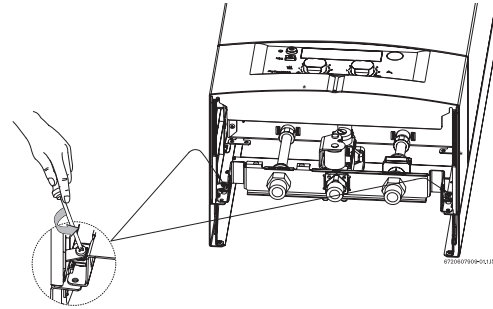

Fig. 2 Screws

- ▶ Pull control panel outwards and then pull it downwards (Fig. 3).

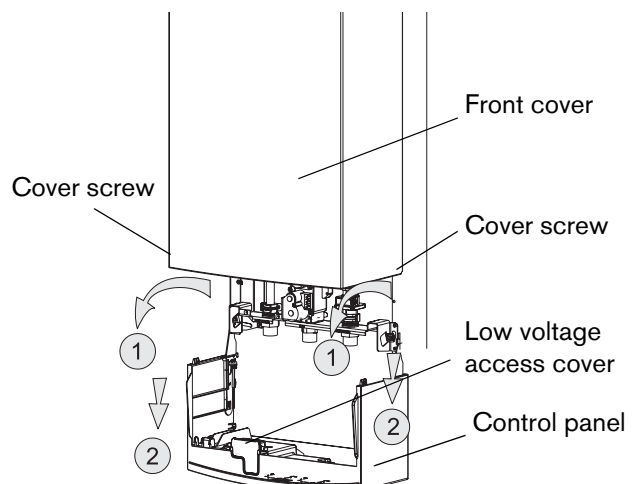

Fig. 3 Service position to access water and electric connections

- ▶ Lift front cover upward and remove.
- ▶ Remove cover screws.

To remove combustion cover (service only)

- ▶ Open the four clips and remove the combustion cover.

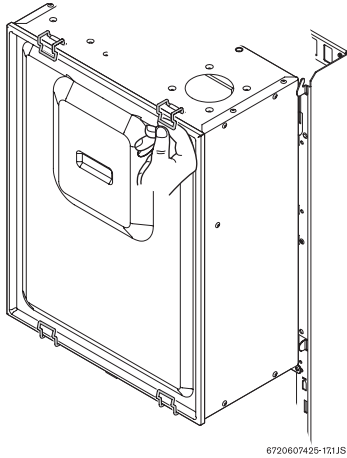

Fig. 4 Remove the combustion cover

The GWH-345/450-ESR is not approved or designed for:

- Manufactured (mobile) homes, RV's or boats. (Modular homes are acceptable for installation).
- Outdoor installation
- Combination venting with other appliances
- Closed loop heating applications
- Use above 8,000 ft A.S.L. altitude.

2.4 General rules to follow for safe operation

1. You must follow these instructions when you install your heater. In the United States: The installation must conform with local codes or, in the absence of local codes, the National Fuel Gas Code ANSI Z223.1/NFPA 54. In Canada: The Installation must conform with CGA B149.(1,2) INSTALLATION CODES and /or local installation codes.
2. Carefully plan where you install the heater. Correct combustion air supply and vent pipe installation are very important. If not installed correctly, fatal accidents can be caused by lack of air, carbon monoxide poisoning or fire.
3. When the unit is installed indoors with ROOM SEALED (twin pipe) combustion air and venting, it is permitted to be located in bathrooms, bedrooms and occupied rooms that are normally kept closed. See chapter 3.6. If the unit will be installed indoors and use indoor combustion air, the place where you install the heater must have enough ventilation. The National Fire Codes do not allow UNSEALED gas fired water heater installations in bathrooms, bedrooms or any occupied rooms normally kept closed. See chapter 3.2 and 3.5.
4. You must vent your heater. See chapter 3.6 Venting.
5. The appliance and its gas connection must be leak tested before placing the appliance in operation. The appliance must be isolated from the gas supply piping system by closing its individual manual gas shutoff valve (not supplied with heater) during any pressure testing at pressures in excess of 1/2 Psig (3.5 kPa).
6. Keep water heater area clear and free from combustibles and flammable liquids. Do not locate the heater over any material which might burn.
7. Correct gas pressure is critical for the optimum operation of this heater. Gas piping must be sized to provide the required pressure at the maximum output of the heater, while all the other gas appliances are in operation. Check with your local gas supplier, and see the section on connecting the gas supply.
8. Should overheating occur or the gas supply fails to shut off, turn off the gas supply at the manual gas shut off valve, on the gas line. Note: manual gas shutoff valve is not supplied with the heater.
9. Do not use this appliance if any part has been underwater. Immediately call a qualified service technician to inspect the appliance and to replace any part of the control system and any gas control which has been underwater.
10. Failure to install heater correctly may lead to unsafe operation and void the warranty.
11. If the heater is installed in an area where temperatures are below 42°F, the heater will activate to prevent freezing. **The piping outside the appliance will not be protected.** See Chapter 4.7 for additional freeze prevention information.
12. In areas where water supply has a high mineral content, a water softener is strongly recommended. A water softener is required if the water hardness exceeds 6 grains/gal (103 mg/l) calcium carbonate. Damage to the water heater resulting from hard water/scale deposits will not be covered under warranty.

2.5 Dimensions and minimum installation clearances

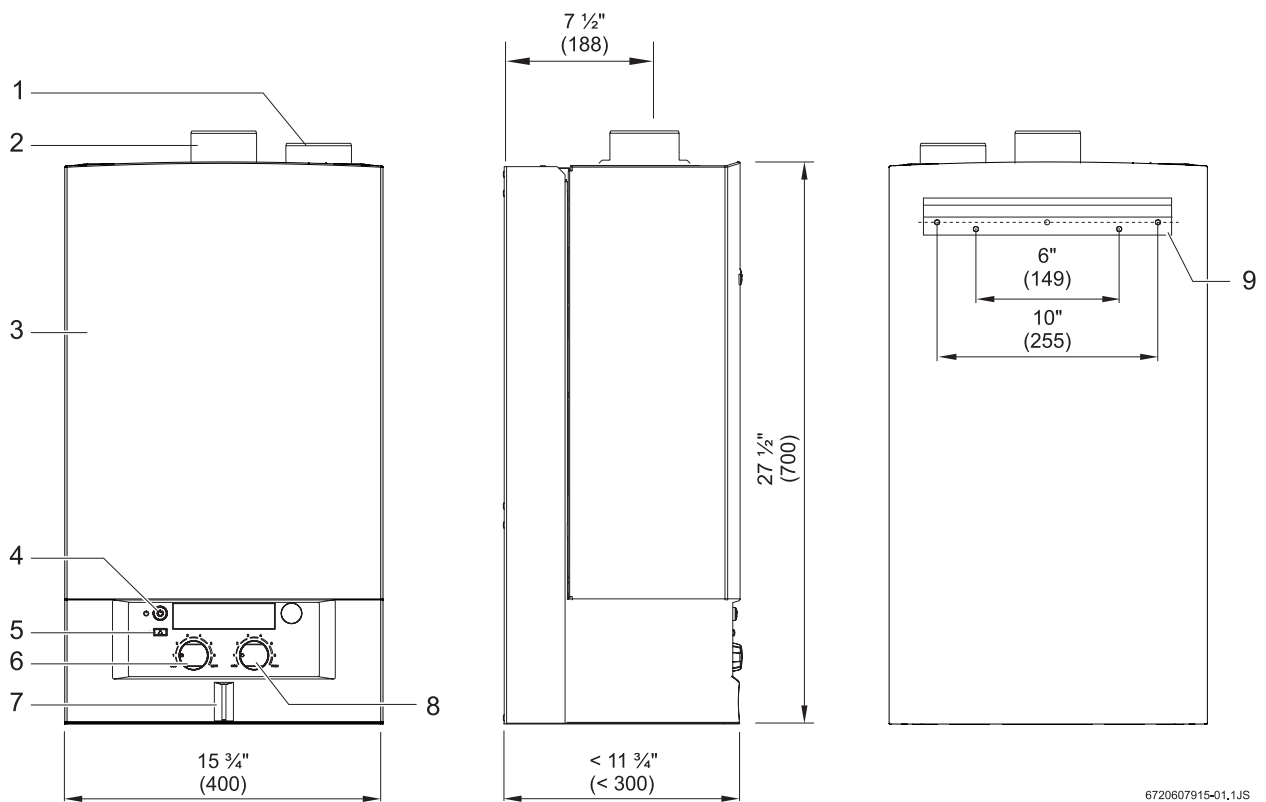

6720607915-01,1JS

Fig. 5 Dimensions

- 1 Combustion air inlet adapter (right side only)
- 2 Exhaust adapter with CO₂ measuring point
- 3 Front cover
- 4 On/Off button
- 5 Reset button
- 6 Recirculating water temperature selector
- 7 LED - (ON) warning light (blinks when in error lock out)
- 8 Domestic hot water temperature selector
- 9 Mounting bracket

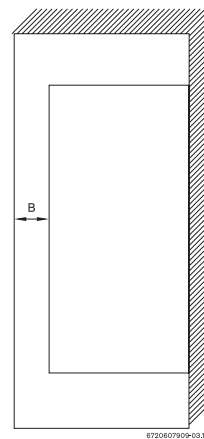

6720607915-02,1JS

Fig. 6 Minimum clearances

	Model GWH-345/450-ESR
TOP	12"
FRONT (B)	4"
BACK	0"
SIDES	1/2"
BOTTOM	12"

Table 1 Minimum clearances

2.6 Applications



Caution: the water heater which will be used to supply potable water shall not be connected to any heating system or component(s) previously used with a nonpotable water heating appliance.

Introduction

The application designs provided in this manual are general guides to be used when installing this recirculating water heater.

Pump Sizing

Required PS pumps are Taco 007 Bronze or Grundfos 15-42B. PZ pumps should be sized by a professional plumbing contractor based on the specific application.



Caution: Do not overpump the heater. Maximum 5 gpm water flow permitted through the heater.

Instantaneous water heater (direct tank load design)

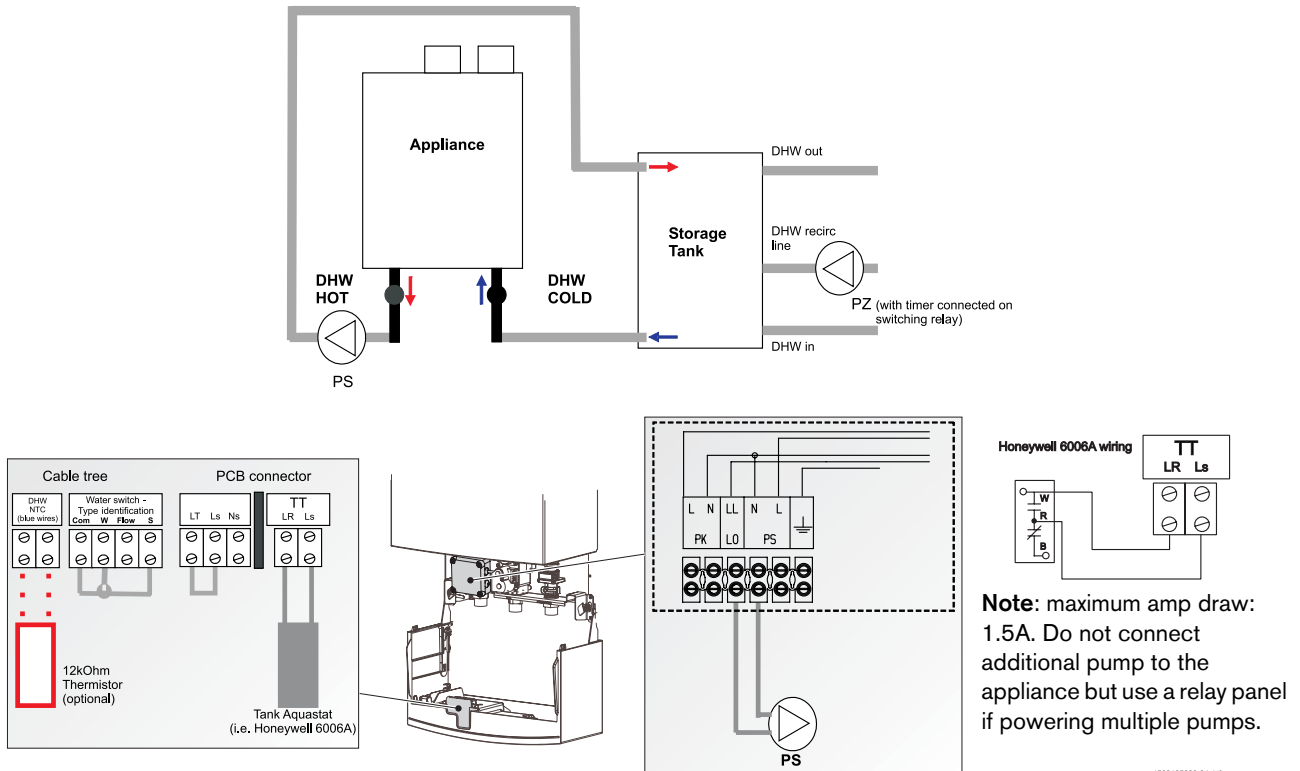

Fig. 7

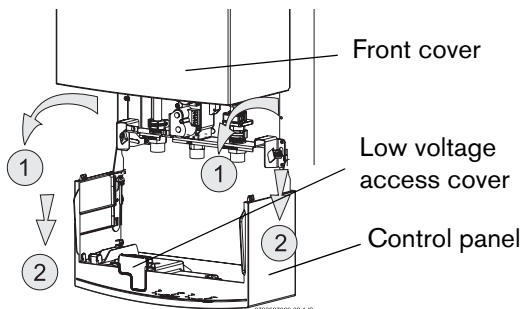

Fig. 8 Service position to access water and electric connections

Pressure drop curves

Note: Flow above 5 GPM is not permitted.

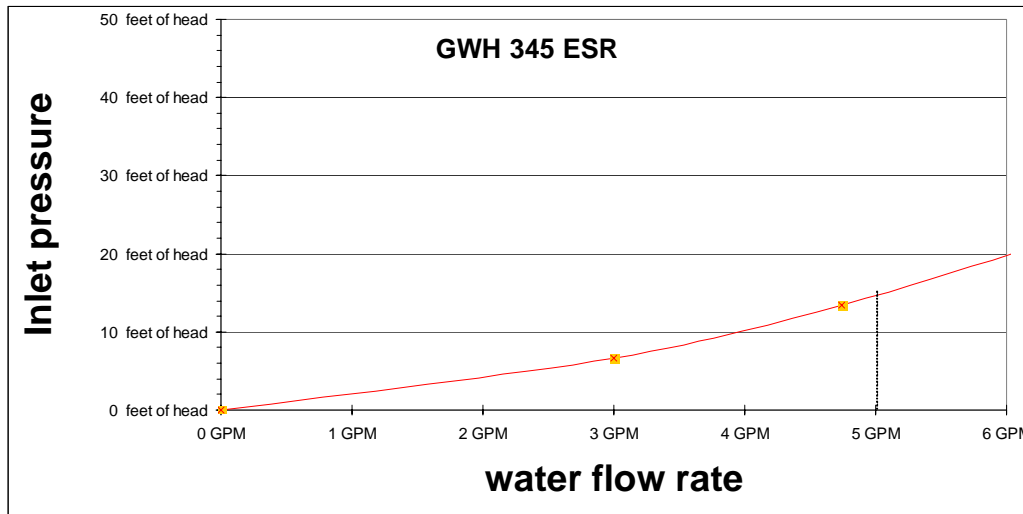

Fig. 9 GWH 345 ESR

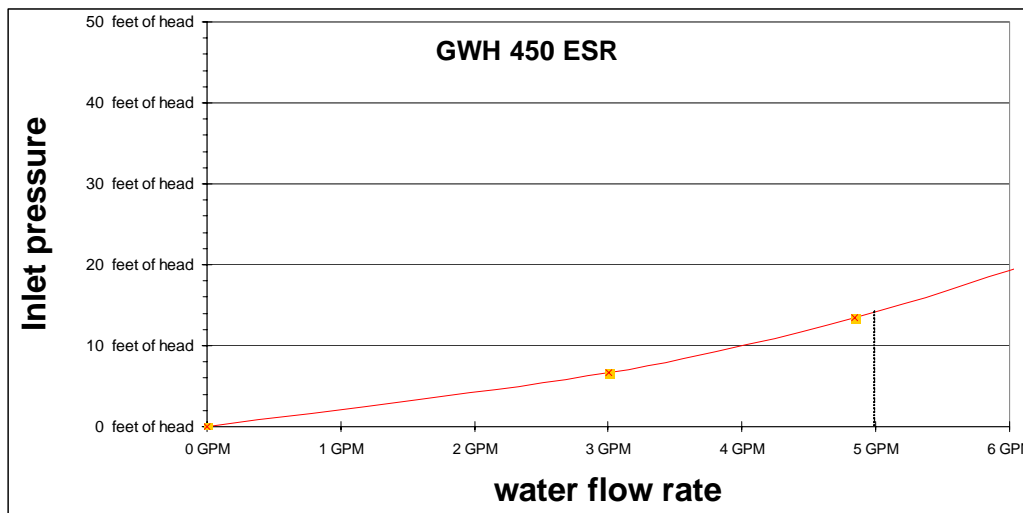

Fig. 10 GWH 450 ESR

2.7 Water quality

Water quality can have an impact on appliance performance and appliance longevity, and may not be covered by the manufacturer's warranty.

For water analysis data call your local water department. If on a well system, have well water analyzed periodically. If water quality is exceeding one or more of the values specified below, Bosch recommends installing a water conditioner or softener.

Description	pH	TDS (Total Dissolved Solids)	Total hardness	Aluminum	Chlorides	Copper	Iron	Manganese	Zinc
Max. Levels	pH range	mg/l or ppm	mg/l or ppm	mg/l or ppm	mg/l or ppm	mg/l or ppm	mg/l or ppm	mg/l or ppm	mg/l or ppm
	6.5-8.5	500	100 (6 grains)	0.2	250	1.0	0.3	0.05	5.0

Table 2 Water Quality Specifications

3 Installation instructions

3.1 Introduction

Please follow these instructions. Failure to follow instructions may result in:

- Property damage or personal injury
- Improper operation
- Heater damage
- Loss of warranty.

Please contact Bosch Water Heating with any questions.

3.2 Proper location for installing your heater

Carefully select the location of the water heater. For your safety and for proper heater operation, you must provide combustion air to the heater and a proper exhaust vent system.

Follow the guidelines below:

- ▶ **1.** Locate the heater where venting, gas and plumbing connections are feasible and convenient.
- ▶ **2.** The hot water lines should be kept short to save energy. Centrally locating the water heater is best. It is always best to have hot water lines insulated.



Warning: The water in this recirculating water heater is cold and always remains cold except for the times the burners are on. In the event of power outage in conjunction with freezing temperatures, it is recommended that the heater be drained to prevent heater from freezing. See chapter 10 for draining instructions.



Warning: Flammable materials, gasoline, pressurized containers, or any other items or articles that are potential fire hazards must NOT be placed on or adjacent to the heater. The appliance area must be kept free of all combustible materials, gasoline and other flammable vapors and liquids.

3.3 Heater placement and clearances

The GWH-345/450-ESR is design certified for installation on a combustible wall (see 3.4 Mounting installation) provided the floor covering below the heater is noncombustible. For installations in an alcove or closet, maintain the minimum clearances to combustible and non-combustible materials listed below. See also fig. 6.

- A. Top 12 inches (305 mm)
- B. Front 4 inches (100 mm)
- C. Back 0 inches
- D. Sides ½ inches (12 mm)
- E. Bottom 12 inches (305 mm)

Clearances from any exhaust vent pipe are dependent upon the clearance requirements of the stainless steel vent pipe manufacturer. Single wall sealed stainless steel (AL29-4C) vent pipe (rated for Category III appliances) must be used when exhaust venting this appliance. See 3.6 Venting.

3.4 Mounting installation



Warning: before starting installation:

- ▶ check that there are no loose parts inside the appliance
- ▶ check that the gas type of the heater matches the gas supply you will be connecting to the heater.
- ▶ ensure that gas pipe, gas valve, fan and burner have no damage and are properly fitted.



Front cover should be removed (see instructions on page 5) in order to inspect components visually.

- ▶ Secure the wall mounting bracket provided with the heater to a wall surface.



Warning: Do not install this appliance on a carpeted wall. The heater must be mounted on a wall using appropriate anchoring materials.

If wall is a stud wall sheathed with plaster or drywall, it is recommended that support board(s), either 1x4's or 1/2" (minimum) plywood first be attached across a pair of studs. Then attach the heater's bracket to the upper support board. The heater should be kept level on the wall surface. See Fig. 11.

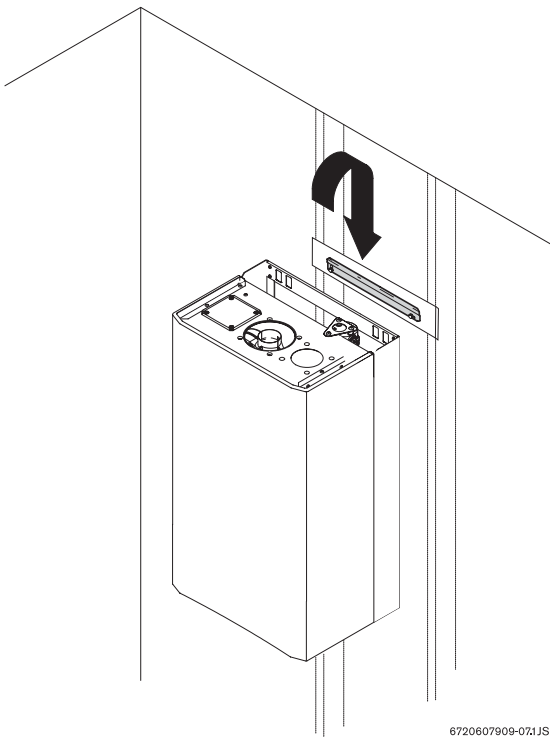

6720607909-07.1JS

Fig. 11 Mounting the heater

3.5 Combustion air requirements



Warning: In areas where freezing temperatures are common the twin pipe system is recommended. In a single pipe installation, a negative air condition may result in cold air being drawn across the heat exchanger coil causing it to freeze and burst. **This failure is not covered under the manufacturer's warranty.**



Warning: When installed in an environment where corrosive chemicals or dirty air are present the twin pipe system is required.

Twin pipe

The GWH-345/450-ESR is designed as a sealed combustion appliance. It is recommended that the combustion air be provided by a dedicated 3" pipe to the outside. If terminating combustion air piping horizontally, pitch vent down 1/4" per foot towards termination to prevent rain from entering the appliance. The combustion air pipe may be constructed of aluminum flex, PVC or any other rigid or semi rigid sealed pipe. The combustion air inlet must be located in such a manner as to provide a minimum 3 foot distance from the exhaust vent terminator.

The maximum length of the combustion air inlet is 39 feet with one elbow. Subtract 3 feet for each additional

90° elbow and 1.5 feet for each 45° elbow. Maximum number of elbows permitted is 4 (see Table 6).

Single pipe

Note: This appliance requires 6200 cubic feet of available combustion air, or a minimum of 775 square feet of space with an 8 foot ceiling to operate. If the large amount of air space, which equates to about half of most average sized homes, is not available, the appliance must pull air from outside (see twin pipe system above).

Although it is permissible to draw combustion air from inside the structure, it is not the manufacturer's recommended installation method. Always install a 3 inch elbow on the combustion air inlet to prevent foreign objects from falling into the unit (see Fig. 12).

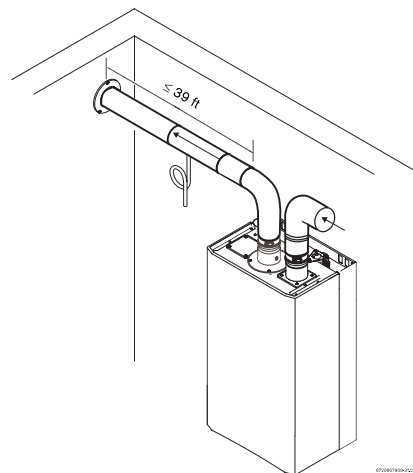

6720607909-07.2JS

Fig. 12

If a single pipe installation is utilized, follow guidelines below for providing adequate combustion air for the water heater as well as any other appliances that may consume air in the space. Always follow local codes if they are more stringent.

This Installation Manual specifies the minimum exhaust vent length and the amount of combustion air required for this unit. When all requirements are followed, the unit will operate properly and safely. However, there may still be a risk of freezing due to negative draft if the other combustion appliances in the building are not supplied with sufficient combustion air. A wood stove or furnace can pull its combustion air from the heater's vent pipe, allowing the cold incoming air to freeze the cold water in the heat exchanger. Supplying more combustion air for all combustion appliances is the solution. A HVAC specialist should be consulted to design solutions for providing more combustion air. Observe the following guidelines:

Installations in structures that have been tightly constructed (air infiltration rate of 0.40 ACH or less) must be provided with combustion air per the National Fuel Gas Code. Consult a HVAC specialist if your air infiltration rate is questionable.

Installation instructions

The space must have two permanent openings, one commencing within 12 inches of the top and one commencing within 12 inches of the bottom of the enclosure.

Each opening must have a minimum free area of one square inch per:

- 1000 Btu/hr if all air is taken from inside the building.
- 2000 Btu/hr if all air is taken from the outside by horizontal ducts.
- 4000 Btu/hr if all air is taken from the outside by direct openings or vertical ducts.

Or the space must be provided with one permanent opening or duct that is within 12 inches of the ceiling of the enclosure

This opening must have a minimum free area of one square inch per:

- 3000 Btu/hr if all air is taken from the outside by a direct opening or vertical duct.

Louvers, grills and screens have a blocking effect. If the effective free area is not known, increase the sizes of your openings by 300% if your louvers are wood and by 43% if your louvers are metal. Refer to the National Fuel Gas Code for complete information.

3.6 Venting

Danger: Do not combination vent this appliance with any other appliance.

Warning: Do not reduce the vent (exhaust and combustion) pipe sizes.

Warning: Failure to vent the exhaust gases to the outside with sealed stainless steel vent pipe (AL29-4C) may result in dangerous flue gases filling the structure in which it is installed.

Warning: Do not mix vent pipe or joining methods from different manufacturers.

Caution: The vent system must be installed by a qualified individual or agency in accordance with these instructions. If improperly installed, a hazardous condition such as fire or carbon monoxide poisoning could result. Bosch Thermotechnology Corp. will not be responsible for improperly installed appliances.

3.6.1 Vent material and specifications

Establish vent clearances that comply with the vent manufacturer's specifications. In all cases follow local codes.

Note: Listed thimbles or collars are necessary to pass through wall and ceiling partitions. If the vent system passes through combustible areas where the vent clearance requirements cannot be maintained, it is permissible to chase straight sections of sealed 3 inch single wall vent through 4 inch (or greater) Type-B vent. The distance to combustibles using this chase technique is 1 inch.

Warning: Type-B vent should never be used as the actual exhaust vent system for the appliance, as it is not gas tight.

Vent lengths

The appliance should be located as close to the point of termination as possible.

The maximum equivalent exhaust length is 39 feet with one 90 degree elbow. Subtract 3 feet for each additional 90 degree elbow used (a maximum of four elbows are permitted in the exhaust vent)¹⁾.

The maximum equivalent inlet air supply pipe

length is 39 feet with one 90 degree elbow. Subtract 3 feet for each additional 90 degree elbow used (a maximum of four elbows are permitted in the inlet air supply)²⁾ see Table 6.

Horizontal section of vent must pitch upward from heater 1/4" for every foot of horizontal length, to prevent the pooling of condensate, and be supported at 4 foot intervals with overhead hangers. See Table 3. The last horizontal run including the termination must be sloped to the outside 1/4" per foot to prevent rain from entering the venting system.

	Diam.	Max. equivalent length	Material
Exhaust Vent	3 inches	39 feet with 1 elbow	Sealed stainless steel (AL29-4C)
Intake Vent	3 inches	39 feet with 1 elbow	Aluminum flex, PVC or any other rigid or semi rigid sealed 3" pipe

Table 3 Venting Specifications

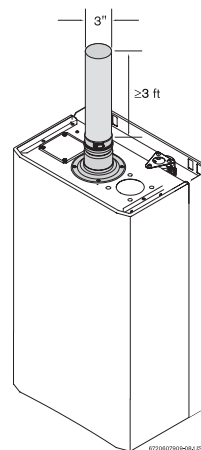

The minimum exhaust vent length is 3 feet.

The use of a 90 degree elbow is equivalent to 3 ft in vent length. The use of 45 degree elbow is equivalent to 1.5 ft in vent length.

Fig. 13 Minimum exhaust vent length

1) or subtract 3 feet for each 90° elbow used
 2) or subtract 1.5 feet for each 45° elbow used

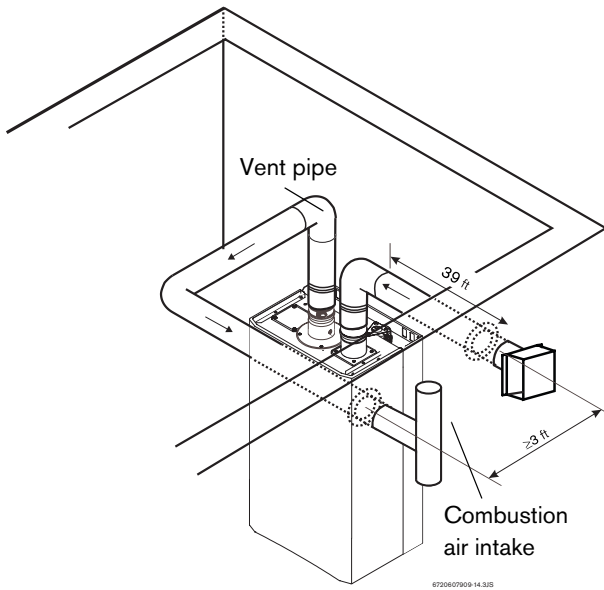

Fig. 14 Maximum vent and combustion air lengths

Vent material

The GWH-345/450-ESR requires 3 inch sealed single wall stainless steel vent pipe (AL29-4C). Use of any other vent material will void the manufactures warranty and may result in a hazardous condition. For specific questions concerning vent material, specifications, usage or installation, contact the vent manufacturer directly.

Company	Contact information
Z-flex	www.z-flex.com 800-654-5600
ProTech Industries	www.protechinfo.com 800-766-3473
Heat-Fab	www.heatfab.com 800-772-0739

Table 4 Vent manufacturer contact information

	Z flex	Protech	Heat Fab
3" Horizontal terminator	TEE only	TEE only	9390 TEE
3" Vertical terminator	2SVSRCF03	FSRC3	5300CI
90° Condensate drain Tee	2SVEVWCF03	FST3 & FSDF3	93PLSTEE
Horizontal Condensate drain	2SVEDWCF03	FSHD03	9321
Condensate Drain Tube	2SVEDTK	N/A	7000TUBE

Table 5 Approved vent termination and condensate drain part numbers (subject to change)

Contact your Bosch supplier for stocked vent material.

Vent Safety System

The GWH-345/450-ESR will shut down if inadequate exhaust venting is detected or a lack of combustion air is provided to the unit; see troubleshooting section on page 34. Correct the problem and then reset the heater before operating.

3.6.2 Vent connections and combustion air inlet restrictors

Exhaust vent connection

- ▶ Attach the flue gas exhaust accessory (8 705 504 142) to the top of the unit (position 1) using the 4 screws and gasket provided
- ▶ Insert 3" single wall stainless steel vent pipe into exhaust vent adapter 1.5" and tighten the clamp (position 2).

Note: Failure to fully insert and tighten vent pipe may cause flue gas leakage or condensate damage that is not covered under the manufacturer's warranty.

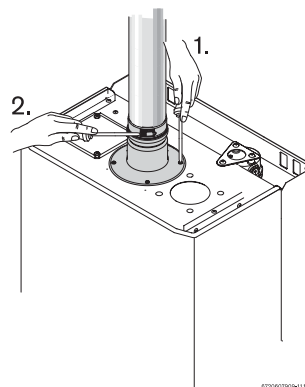

Fig. 15 Exhaust vent connection

Selecting combustion air inlet restrictor

Note: Before installing the combustion air inlet accessory, the appropriate inlet air restrictor must be determined using Tables 6, 7 and 8.

Refer to Fig. 16 for mounting sequence.

- ▶ Determine the total length of the straight sections of 3" stainless steel exhaust and enter that length in line 1.
- ▶ Do not count the first 90 elbow used in calculation. Count the number of additional 90 elbows used and enter that value in line 2. (Maximum of 4 90 elbows allowed) and enter that value in line 2.
- ▶ Count the number of 45° elbows used and enter that value in line 3.
- ▶ For model GWH 345 ESR, enter a 1 in line 4 for model GWH 450 ESR enter a 1 in line 5.
- ▶ Repeat steps 1 through 4 for the 3" intake pipe and enter those values in the intake section.
- ▶ Add the totals from the Exhaust table and the Intake table to determine the equivalent vent length. Use this value in Table 6 to determine which restrictor size to use.

Exhaust			
1	Straight section length	__ x 1 =	___
2	90° elbows (qty)	__ x 6 =	___
3	45° elbows (qty)	__ x 3 =	___
4	GWH 345 ESR termination	__ x 15 =	___
5	GWH 450 ESR termination	__ x 12 =	___
6	Total:		___
Combustion Air			
1	Straight section length	__ x .5 =	___
2	90° elbows (qty)	__ x 3 =	___
3	45° elbows (qty)	__ x 1.5 =	___
4	GWH 345 ESR termination	__ x 6 =	___
5	GWH 450 ESR termination	__ x 3 =	___
6	Total:		___
7	Total equivalent vent length =		___

Table 6 Determining equivalent vent length (see example in Table 7)

Note: Do not count the first elbow used.

Example

Exhaust

- 10 - 3' straight sections
- 1 - 1' straight section

Total length 31'

- 2 - 90° elbow
- 1 - GWH 450 ESR termination.

Intake

- 5 - 4' straight sections
- 2 - 1' straight sections

Total length 22'

- 3 - 90° elbows
- 1 - GWH 450 ESR termination.

Example

Exhaust		
Straight section length	21 x 1 =	21
90° elbows (qty)	1 x 6 =	6
45° elbows (qty)	0 x 3 =	0
GWH 345 ESR termination	0 x 15 =	0
GWH 450 ESR termination	1 x 12 =	12
Total:		39
Combustion Air		
Straight section length	22 x .5 =	11
90° elbows (qty)	2 x 3 =	6
45° elbows (qty)	0 x 1.5 =	0
GWH 345 ESR termination	0 x 6 =	0
GWH 450 ESR termination	1 x 3 =	3
Total:		20
Total equivalent vent length =		59

Table 7 Determining equivalent length example

Note: Do not count the first elbow used.

Using table 8, the following restrictors would be required:

- GWH 450 ESR NG - restrictor 55
- GWH 450 ESR LP - restrictor 55.

Use table below to define which restrictor to be used.

	Total equivalent length (ft)	Restrictor Ø
GWH345 NG	20 - 38	38
	38 - 78	40
GWH450 NG	18 - 28	44
	28 - 40	47
	40 - 65	50
	65 - 78	55
	Total equivalent length (ft)	Restrictor Ø
GWH345 LPG	20 - 38	38
	38 - 78	40
GWH450 LPG	18 - 28	47
	28 - 50	50
	50 - 78	55

Table 8 Restrictors table

After installation is complete, check CO₂ levels per chapter 3.9.

Combustion air inlet connection

The combustion air inlet accessory can only be connected to the top right of the appliance. The left side must remain sealed.

Note: Before installing the combustion air inlet accessory, the appropriate inlet air restrictor must be determined using Tables 6, 7 and 8.

Refer to Fig. 16 for mounting sequence.

- ▶ Place gasket, deflector, gasket and inlet air restrictor on the air inlet opening lining up screw holes as seen in Fig. 16.

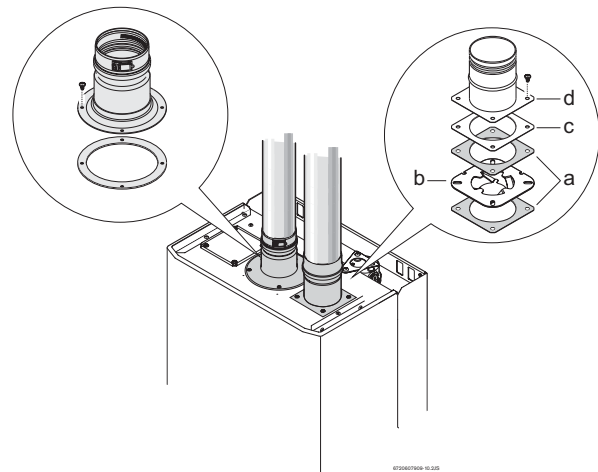

Fig. 16 Mounting sequence

- a Gasket
- b Deflector
- c Restrictor
- d Adaptor

- ▶ Attach the combustion air inlet accessory (8 705 504 141) to the top of the unit (position 3) using the 4 screws provided.
- ▶ Install 3" combustion air pipe over the air inlet accessory.

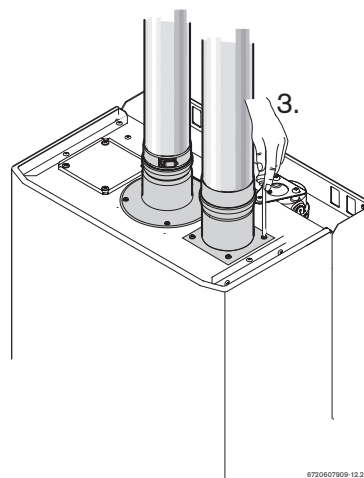

Fig. 17 Combustion air inlet accessory

3.6.3 Condensate drain requirements

An external condensate drain must always be installed except when terminating horizontally with less than 3 feet of pipe.

Note: condensate must be disposed of according to local codes.

1. Install condensate drain as close to heater as possible.
2. Use 3/8" ID high temperature silicone tube to connect to condensate drain port. Do not use copper piping for any portion of the condensate drain.
3. Form a condensate trap by means of a 3" loop partially filled with water to form a gas trap. Add small amount of mineral oil if the trap is drying out.
4. To increase the tube length, connect to end of the high temperature silicone tubing with vinyl tubing, PVC or CPVC pipe. Do not reduce the internal diameter at any point.

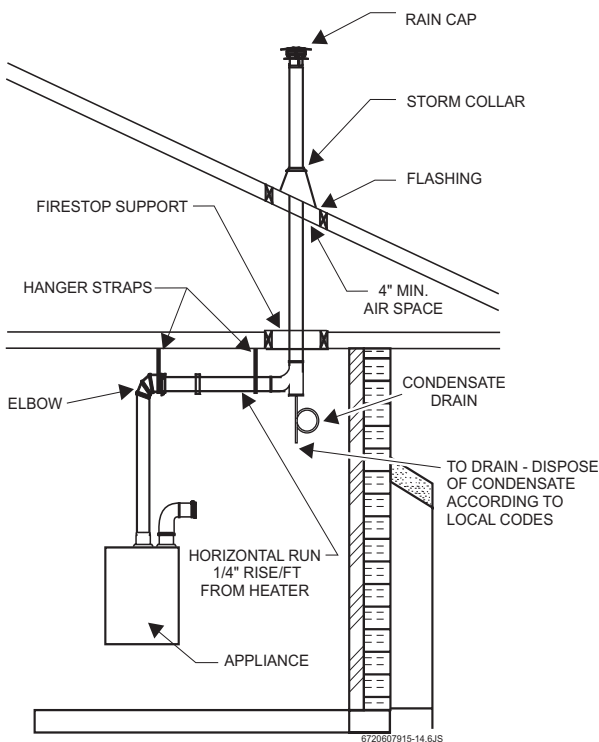

Fig. 18 Required condensate drain installation

3.6.4 Room sealed installation (Twin pipe)

Although it is permitted to draw combustion air from inside, the recommended method is to provide combustion air through a 3" pipe from the outside. See Chapter 3.5 for more direction on combustion air.

To reduce pressure differentials between the exhaust and combustion air intake, it is required that both terminators exit on the same wall or roof. See Fig. 19 for an example horizontal twin pipe termination and Fig. 20 for the vertical twin pipe termination example. Use only approved rain caps. For vertical air inlets use 2 90° elbows with opening facing down and covered with a screen.

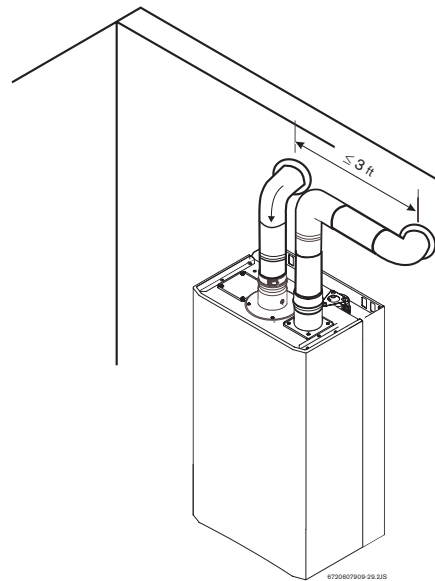

Fig. 19 Horizontal twin pipe termination

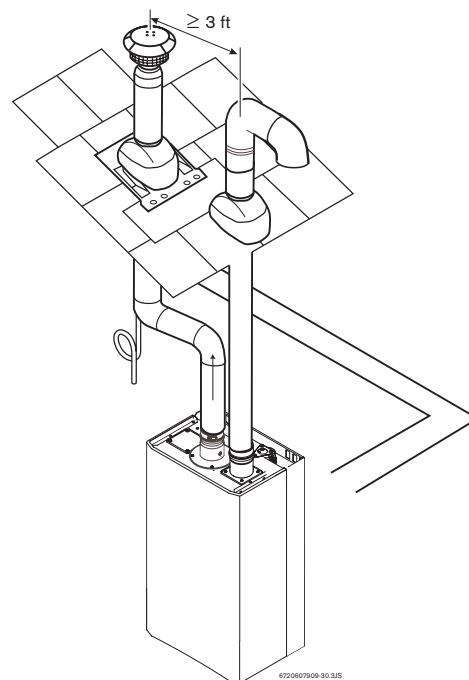

Fig. 20 Vertical twin pipe termination

3.6.5 Vertical terminations



Caution: Failure to install a condensate drain may result in damage not covered by the manufacturer's warranty. See chapter 3.6.3. An approved vent terminator must be used. See Table 5 for known approved vertical vent terminations.

Horizontal runs

Any gas vent section that is greater than 45 degrees from the vertical is considered horizontal. Horizontal sections must slope upwards from heater at least 1/4 inch for every foot of its horizontal length and be properly supported. Exception: after last elbow in vent run, pitch horizontal pipe and termination to the outside 1/4" per foot to prevent rain water from entering the pipe.

Vent terminations

The exhaust vent must terminate above the roof surface with an approved vent cap not less than 2 feet (0.6 m) above the highest point where it passes through the roof and at least 2 feet (0.6 m) higher than any vertical wall or similar obstruction within 10 feet (3.1m). See Fig. 21.

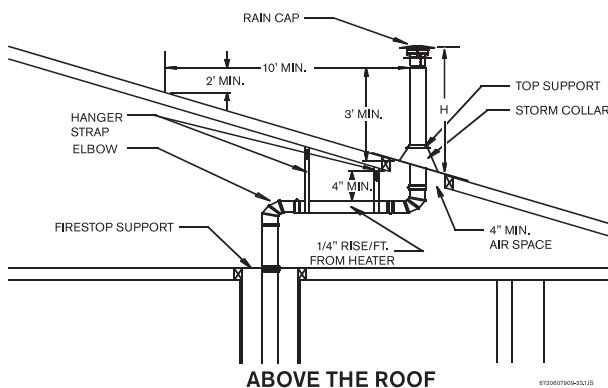

Fig. 21 Vertical vent termination clearances

Interior masonry chimneys

The single wall stainless steel exhaust vent pipe must be permanently mounted inside the masonry chimney. The masonry chimney may have to be tile or metal lined before the insertion of the gas vent pipe; check local codes for clarification.

You may not vent any other fuel burning appliances into any free space remaining in the chimney. The vent terminator must extend at least 3 feet (0.9 m) above where the chimney meets the roofline and at least 2 feet (0.6 m) higher than any vertical wall or similar obstruction within 10 feet (3.1 m). The top of the chimney must be sealed to prevent rain water or other elements from entering the chimney.

Exterior Masonry Chimney

Refer to the National Fuel Gas Code and consult a local venting HVAC contractor. Not recommended in cold climates.

3.6.6 Horizontal terminations



Warning: After last elbow in vent run, pitch horizontal pipe and termination to the outside 1/4" per foot to prevent rain water from entering the pipe.

An approved vent terminator must be used. See Table 5 for known approved horizontal vent terminations. Install a condensate drain if the total straight vent length is greater than 5 feet or if the exhaust vent pipe passes through an unconditioned space.

The exhaust termination tee must project out a minimum of 10" and maximum of 16" on center from the wall thimble.

Fig. 22 and table 9 show the required clearances for the vent termination. Follow local codes if more stringent.

3.6.6.1 Requirements for installation in Massachusetts

Attention residents of the Commonwealth of Massachusetts:

In the Commonwealth of Massachusetts the following regulation went into effect on 12/30/2005:

(a) For all side wall horizontally vented gas fueled equipment installed in every dwelling, building or structure used in whole or in part for residential purposes, including those owned or operated by the Commonwealth and where the side wall exhaust vent termination is less than seven (7) feet above finished grade in the area of the venting, including but not limited to decks and porches, the following requirements shall be satisfied:

1. **INSTALLATION OF CARBON MONOXIDE DETECTORS.** At the time of installation of the side wall horizontal vented gas fueled equipment, the installing plumber or gasfitter shall observe that a hard wired carbon monoxide detector with an alarm and battery back-up is installed on the floor level where the gas equipment is to be installed. In addition, the installing plumber or gasfitter shall observe that a battery operated or hard wired carbon monoxide detector with an alarm is installed on each additional level of the dwelling, building or structure served by the side wall horizontal vented gas fueled equipment. It shall be the responsibility of the property owner to secure the services of qualified licensed professionals for the installation of hard wired carbon monoxide detectors.
 - a. In the event that the side wall horizontally vented gas fueled equipment is installed in a crawl space or an attic, the hard wired carbon monoxide detector with alarm and battery back-up may be installed on the next adjacent floor level.
 - b. In the event that the requirements of this subdivision can not be met at the time of completion of installation, the owner shall have a period of thirty (30) days to comply with the above requirements; provided, however, that during said thirty (30) day period, a battery operated carbon monoxide detector with an alarm shall be installed.

2. **APPROVED CARBON MONOXIDE DETECTORS.** Each carbon monoxide detector as required in accordance with the above provisions shall comply with NFPA 720 and be ANSI/UL 2034 listed and IAS certified.

3. **SIGNAGE.** A metal or plastic identification plate shall be permanently mounted to the exterior of the building at a minimum height of eight (8) feet above grade directly in line with the exhaust vent terminal for the horizontally vented gas fueled heating appliance or equipment. The sign shall read, in print size no less than one half (1/2) inch in size, "GAS VENT DIRECTLY BELOW. KEEP CLEAR OF ALL OBSTRUCTIONS".

4. **INSPECTION.** The state or local gas inspector of the side wall horizontally vented gas fueled equipment shall not approve the installation unless, upon inspection, the inspector observes carbon monoxide detectors and signage installed in accordance with the provisions of 248 CMR 5.08(2)(a)1 through 4.

(b) **EXEMPTIONS:** The following equipment is exempt from 248 CMR 5.08(2)(a)1 through 4:

1. The equipment listed in Chapter 10 entitled "Equipment Not Required To Be Vented" in the most current edition of NFPA 54 as adopted by the Board; and
2. Product approved side wall horizontally vented gas fueled equipment installed in a room or structure separate from the dwelling, building or structure used in whole or in part for residential purposes.

(c) **MANUFACTURERS REQUIREMENTS - GAS EQUIPMENT VENTING SYSTEM REQUIRED.** When the manufacturer of Product Approved side wall horizontally mounted gas equipment provides a venting system design or venting system components with the equipment, the instructions provided by the manufacturer for the installation of the equipment and the venting shall include:

1. Detailed instructions for the installation of the venting system or the venting system components; and
2. A complete parts list for the venting system design or venting system.

(d) **MANUFACTURER REQUIREMENTS - GAS EQUIPMENT VENTING SYSTEM NOT PROVIDED.** When the manufacturer of a product approved side wall horizontally vented gas fueled equipment does not provide the parts for the venting of flue gases, but identifies "special venting systems," the following requirements shall be satisfied by the manufacturer:

1. The referenced "special venting system" instructions shall be included with the appliance or equipment installation instructions; and
2. The "special venting systems" shall be product approved by the Board, and the instructions for that system shall include a parts list and detailed installation instructions.

(e) A copy of all installation instructions for all products approved side wall horizontally vented gas fueled equipment, all venting instructions, all parts lists for venting instructions, and/or all venting design instructions shall remain with the appliance or equipment at the completion of the installation.

Recommended exhaust vent terminator position

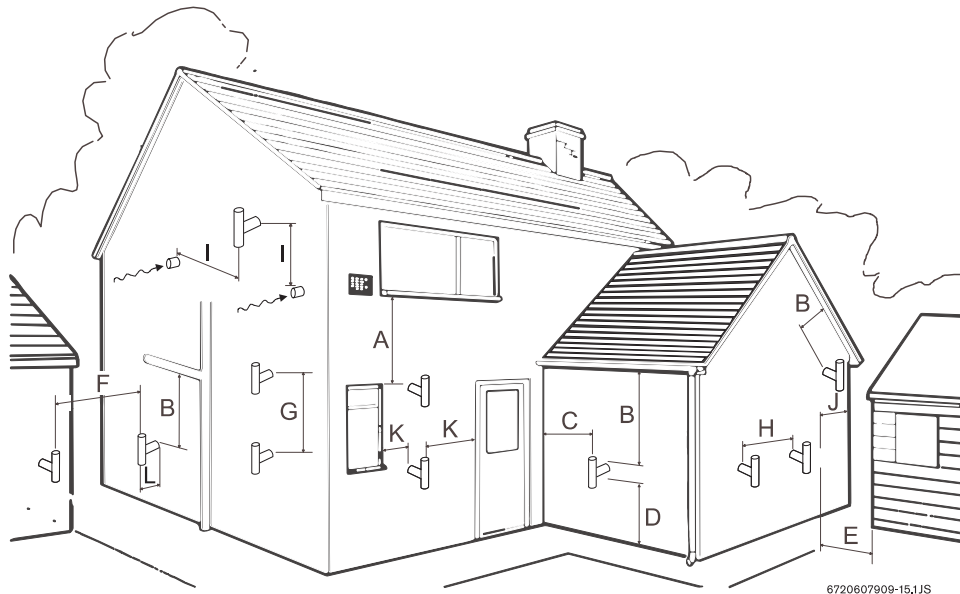

Fig. 22

Ref.	Description	Minimum distance
A	Directly below an opening; operable windows, doors and any non-mechanical fresh air openings	36 in (twin pipe installation) 48 in (single pipe installation)
B	Below a gutter, sanitary pipework or eaves	24 in
	Below a gutter, sanitary pipework or eaves, protected by metal shielding	12 in
C	From any internal corner	12 in
D*	Above ground or snow pack	12 in
	Above a paved sidewalk	7 ft
E	From an opposing wall or structure facing the termination	24 in
	From the relief valve of a lp gas regulator	36 in
F	From a terminator facing a terminator	48 in
G	Vertically between two exhaust vent terminators on the same wall	60 in
H	Horizontally between two exhaust vent terminators on the same wall	12 in
I**	Horizontally and vertically from the combustion air inlet terminator	36 in
	From the gravity combustion air inlet any other equipment	48 in
J	From any external corner	12 in
K	Horizontally from an opening; operable windows, doors and any non-mechanical fresh air openings	12 in
L	From wall on exhaust applications	10 in

Table 9

* Subject to local codes and anticipated snow level

** Other equipment that operates with a mechanical air inlet may require greater distances, reference manufacturer's instructions

NOTICE: Exhaust and air intake must always be located on the same wall to cancel wind pressure effects.

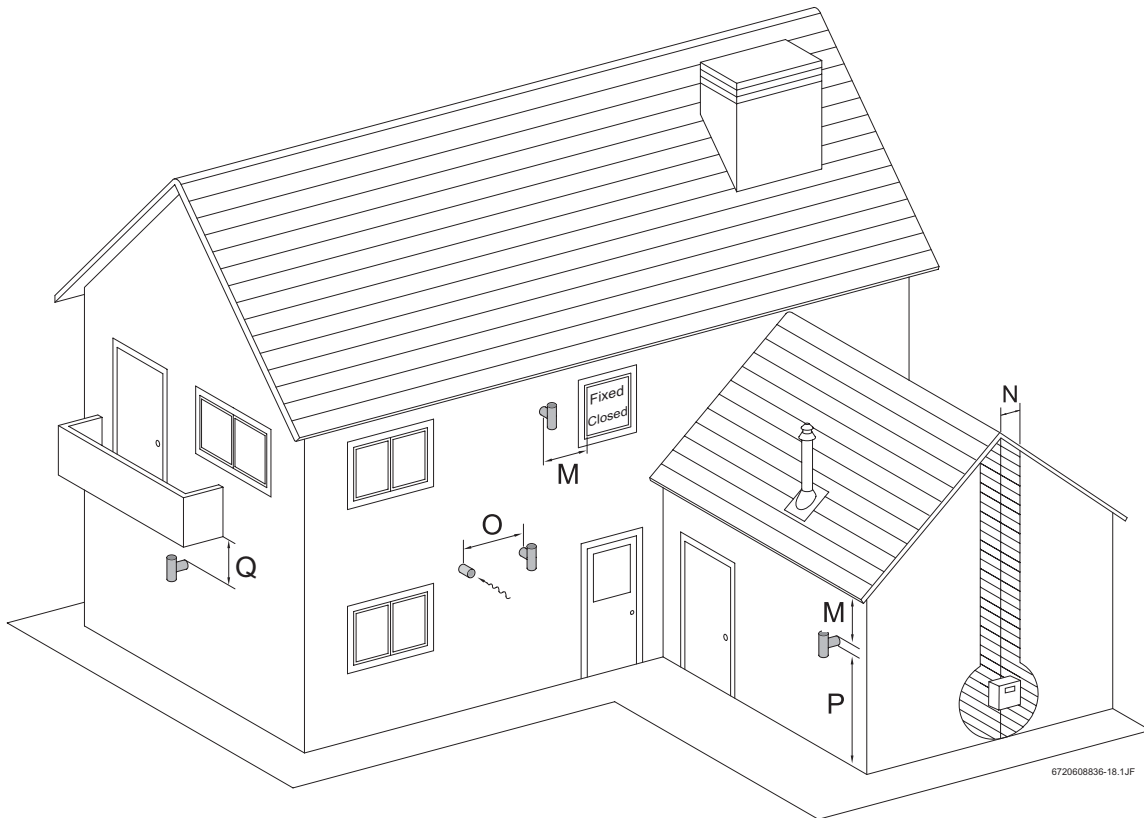

Fig. 23

Ref.	Description	Direct Vent Terminal Clearances		Other than Direct Vent Terminal Clearances	
		Canadian Instalations ¹⁾	US Instalations ²⁾	Canadian Instalations ¹⁾	US Instalations ²⁾
M	Clearance to permanently closed window	*	*	*	*
	Vertical clearance to ventilated soffit located above the terminal within a horizontal distance of 2 feet (61 cm) from the center line of the terminal	N/A	N/A	*	*
N	Clearance to each side of center line extended above meter/regulator assembly	3 feet (91 cm) within a height 15 feet above the meter/regulator assembly	*	3 feet (91 cm) within a height 15 feet above the meter/regulator assembly	*
O	Clearance to a mechanical air supply inlet	6 feet (1.83 m)	3 feet (91 cm) above if within 10 feet (3 m)	6 feet (1.83 m)	3 feet (91 cm) above if within 10 feet (3 m)
P	Clearance above paved sidewalk or paved driveway located on public property	7 feet (2.13 m) ³⁾	*	7 feet (2.13 m) ³⁾	7 feet (2.13 m)
Q	Clearance under veranda, porch, deck or balcony	12 inches (30cm) ⁴⁾	*	12 inches (30cm) ⁴⁾	*

Table 10 Vent terminal clearances

- 1) In accordance with the current CSA B149.1 *Natural Gas and Propane Installation Code*.
 - 2) In accordance with the current ANSI Z223.1 / NFPA 54 *National Fuel Gas Code*
 - 3) A vent shall not terminate directly above a sidewalk or paved driveway that is located between two single family dwellings and serves both dwellings.
 - 4) Permitted only if veranda, porch, deck or balcony is fully open a minimum of two sides beneath the floor.
- * For clearances not specified in ANSI Z223.1 / NFPA 54 or CSA -B149.1. "Clearances in accordance with local installation codes and the requirements of the gas supplier."

3.6.7 Exhaust vent configuration examples

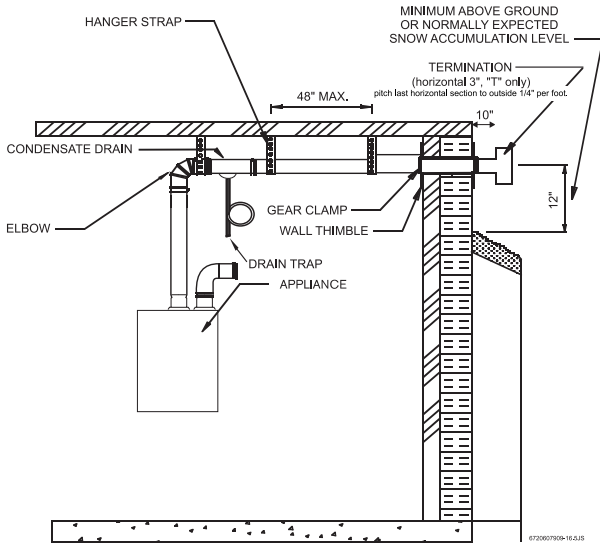

Fig. 24 Horizontal side wall venting installation

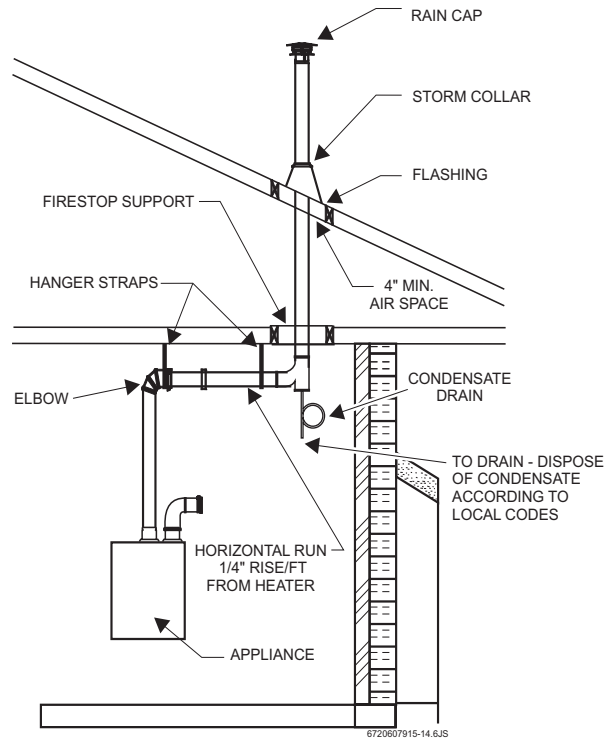

Fig. 26 Vertical venting installation

NOTE: If appliance uses room air, do not place any other combustion appliance in the same space, to avoid depressurizing of the building and winter freeze-up. Use room sealed operation instead.

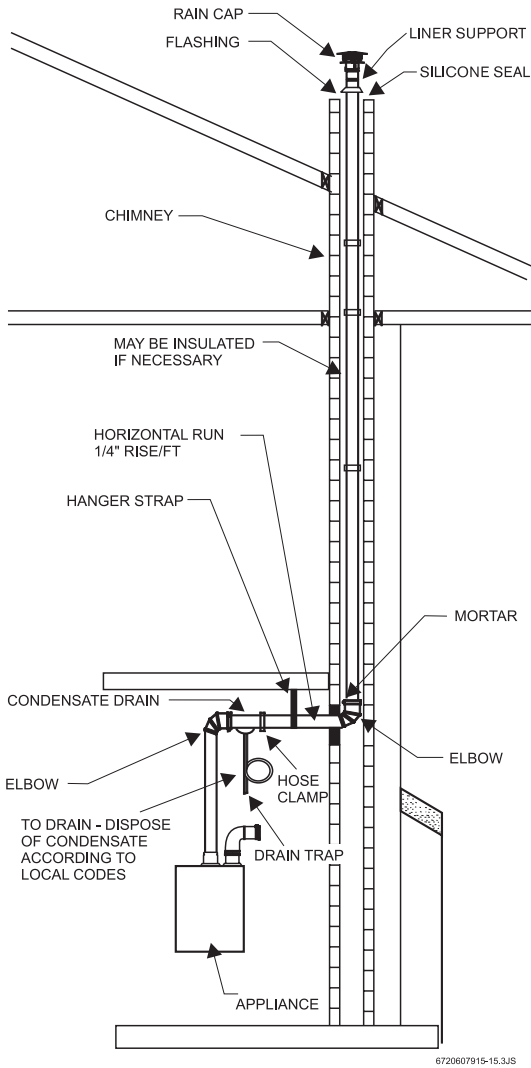

Fig. 25 Vertical venting installation - Masonry Chimney

3.7 Gas piping & connections

Before connecting the gas supply, check the rating plate on the right side of the heater to be sure that the heater is rated for the same gas to which it will be connected.

In the United States: The installation must conform with local codes or, in the absence of local codes, the National Fuel Gas Code ANSI Z223.1/NFPA 54.

In Canada: The installation must conform to CGA B149 INSTALLATION CODES and/or local installation codes.



Warning: DO NOT connect to an unregulated or high pressure propane line or to a high pressure commercial natural gas line.



Warning: The heater must be isolated from the gas supply piping system during any pressure testing of that system at test pressures equal to or more than 0.5 psig. If overpressure has occurred, such as through improper testing of the gas lines or malfunction of the supply system, the gas valve must be checked for safe operation.

GAS CONNECTIONS

- ▶ Install a manual gas shut off valve (installer supplied) on the gas supply line.
- ▶ Install a union when connecting gas supply.
- ▶ The minimum diameter required for any appliance connector used is 3/4".
- ▶ National Fuel Gas Code requires that a sediment trap (drip leg) be installed on gas appliances not so equipped. The drip leg must be accessible and not subject to freezing conditions. Install in accordance with the recommendations of the serving gas supplier.

When connections are made, check for gas leaks at all joints. Apply some gas leak detection solution to all gas fittings. Bubbles are a sign of a leak. A combustible gas detector may also be used to detect for leaks.



Danger: If you have a leak, shut off the gas. Tighten appropriate fittings to stop leak. Turn the gas on and check again with a gas leak detection solution. Never test for gas leaks using a match or flame.

GAS LINE SIZING

The gas supply piping should be sized according to the applicable code for a maximum draw of 120,000 BTUH (GWH450ESR) or 96,000BTUH (GWH345ESR).

Measure the length of gas supply line and use the tables in Fig. 28 or the gas line manufacturer's sizing tables to determine the pipe diameter necessary to accommodate the BTU demand of the unit. If there are more gas drawing appliances on the line, size the gas line according to the total maximum amount of BTU draw for all appliances.

Note: Under sizing the gas line may result in diminished output and improper operation. See chapter 3.8 for the procedure to confirm gas pressure.

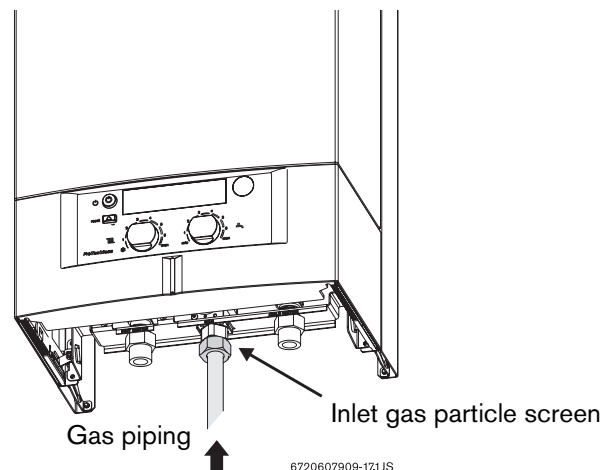

Fig. 27

FOR NATURAL GAS

Maximum Capacity of pipe in Cubic Feet of Gas per Hour for Gas Pressure of 0.5 Psig or less and a Pressure drop of 0.3 in Water Column (0.75mbar).(Based on a 0.60 Specific Gravity Gas) Btu numbers given in thousands.

Follow boxed numbers for piping just one GWH-450-ESR (example: 3/4" B.I. Natural Gas pipe for 20 ft (6.1m). will handle 190,000 btu's (55.7 kWh). For multiple appliances combine the total btu input load and then refer to applicable chart below. Follow the shaded numbers for just one GWH-345-ESR.

Nominal Iron Pipe Size, (inches)	Internal Diameter (inches)	Length of Black Iron Pipe, Feet													
		10	20	30	40	50	60	70	80	90	100	125	150	175	200
1/4	0.364	32	22	18	15	14	12	11	11	10	9	8	8	7	6
3/8	0.493	72	49	40	34	30	27	25	23	22	21	18	17	15	14
1/2	0.622	132	92	73	63	56	50	46	43	40	38	34	31	28	26
3/4	0.824	278	190	152	130	115	105	96	90	84	79	72	64	59	55
1	1.049	520	350	285	245	215	195	180	170	160	150	130	120	110	100
1 1/4	1.380	1050	730	590	500	440	400	370	350	320	305	275	250	225	210
1 1/2	1.610	1600	1100	890	760	670	610	560	530	490	460	410	380	350	320
2	2.067	3050	2100	1650	1450	1270	1150	1050	990	930	870	780	710	650	610
2 1/2	2.469	4800	3300	2700	2300	2000	1850	1700	1600	1500	1400	1250	1130	1050	980
3	3.068	8500	5900	4700	4100	3600	3250	3000	2800	2600	2500	2200	2000	1850	1700
4	4.026	17,500	12,000	9,700	8,300	7,400	6,800	6,200	5,800	5,400	5,100	4,500	4,100	3,800	3500

Tube size, inches	EHD*	Length of Flexible Corrugated Stainless Steel Tubing (CSST), Feet					
		10	20	30	40	50	60
1/2	18 EHD	82	58	47	41	37	34
3/4	23 EHD	161	116	96	83	75	68
1	30 EHD	330	231	188	162	144	131
1 1/4	37 EHD	639	456	374	325	292	267

* EHD = Equivalent Hydraulic Diameter. The greater the value of EHD, the greater the gas capacity of the tubing.

FOR LP GAS

Maximum Capacity of Pipe in Thousands of BTU per Hour of Undiluted Petroleum Gases (at 11 inches Water Column Inlet Pressure) (Based on a Pressure Drop of 0.5 Inch Water Column).

* EHD = Equivalent Hydraulic Diameter. The greater the value of EHD, the greater the gas capacity of the tubing.

Nominal iron pipe inches	Black Iron Pipe Length of Pipe, Feet										
	10	20	30	40	50	60	80	100	125	150	200
1/2	291	200	160	137	122	110	94	84	74	67	58
3/4	608	418	336	287	255	231	197	175	155	140	120
1	1145	787	632	541	480	434	372	330	292	265	227

Tube size, inches	EHD*	Length of Flexible Corrugated Stainless Steel Tubing (CSST), Feet					
		10	20	30	40	50	60
1/2	18 EHD	129	91	74	64	58	53
3/4	23 EHD	254	183	151	131	118	107
1	30 EHD	521	365	297	256	227	207
1 1/4	37 EHD	971	661	528	449	397	359

Maximum Capacity of Semi-Rigid (flexible, non corrugated) Tubing in Thousands of BTU per Hour of Undiluted Liquefied Petroleum Gases (at 11 inches Water Column Inlet Pressure).

(Based on a Pressure Drop of 0.5 Inch Water Column)

* Source National Fuel Gas Code NFPA 54, ANSI Z223.1 - No Additional Allowance is necessary for an ordinary number of fittings

Outside diameter Inch	Copper Length of Tubing, Feet									
	10	20	30	40	50	60	70	80	90	100
3/8	39	26	21	19	-	-	-	-	-	-
1/2	92	62	50	41	37	35	31	29	27	26
5/8	199	131	107	90	79	72	67	62	59	55
3/4	329	216	181	145	131	121	112	104	95	90

Fig. 28

3.8 Measuring gas pressure

Connecting manometer

- ▶ Turn power off.
- ▶ Shut off gas supply.
- ▶ Remove front cover and locate the inlet gas measuring point (see Fig. 29).
- ▶ Loosen screw inside test point fitting (do not remove) and connect manometer tube on test point.

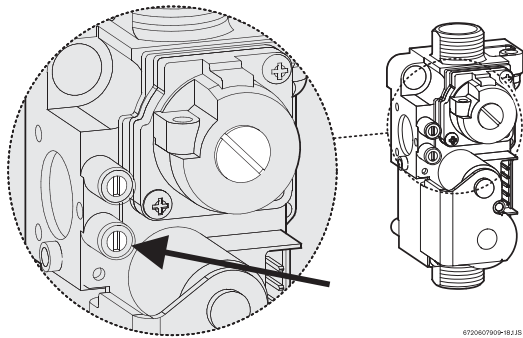



Fig. 29 Gas pressure measuring (lower tapping)

Static pressure test

- ▶ Turn gas supply on.
- ▶ Keep unit off and record **static pressure reading** in Table 11.

Operating pressure test

- ▶ Place a demand for heat by turning external tank thermostat control to maximum for unit to fire at maximum input.
- ▶ Press On/Off button to turn heater On. For this test the unit has to be put in Diagnostic Mode.
- ▶ After 10 seconds, press and hold the reset button .
- ▶ Rotate the recirculating water temperature selector (left knob) to the minimum and then to maximum.
- ▶ Release the reset button and the display should show * (blinking).
The unit has now entered Diagnostic Mode.
- ▶ Operate all other gas appliances on same gas piping system at maximum output.
- ▶ **Record operating pressure reading in Table 11.**
- ▶ Press On/Off button to turn heater Off and exit Diagnostic Mode.



Note: after verification tighten the screw inside the test point.

Operating gas pressures lower than 5.5" W.C. for natural gas or 11" W.C. for LP will result in improper operation and must be corrected. See Chapter 3.7 for gas line sizing requirements.

<p>Static Gas Pressure Reading (see Chapter 3.8)</p> <p>enter here: _____</p>
<p>Operating Gas Pressure Reading (see Chapter 3.8)</p> <p>enter here: _____</p>

Table 11

Manifold pressure test

- ▶ To confirm manifold pressure connect manometer to upper tapping on gas valve. See Fig. 30.

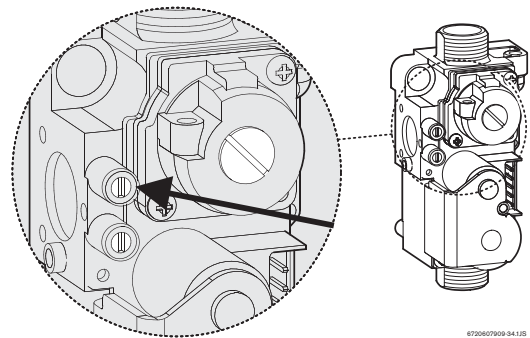

Fig. 30

- ▶ Follow instructions in "operating pressure test" to place unit into Diagnostic Mode.
- ▶ Place a demand for heat by turning external tank thermostat control to maximum for unit to fire at maximum input.
- ▶ Operate all other gas appliances on same gas piping system at maximum output.
- ▶ Compare manometer values with those found in Table 12 below.

Gas valve pressure in W.C.	GWH345		GWH450	
	Min.	Max.	Min.	Max.
Natural Gas	-0.3	3.5	0.5	4.0
Liquid Gas	0.2	8.2	0.0	9.0

Table 12

- ▶ Press On/Off button to turn heater Off and exit Diagnostic Mode.

3.9 Checking restrictor plate size by measuring CO₂ level value.

- ▶ Remove brass flat head screw on the exhaust collar.

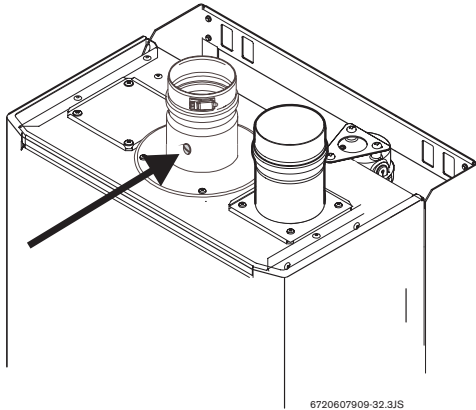



Fig. 31 Measuring port

- ▶ Insert CO₂ analyzer probe into the measuring point. The tip of the probe should be in the center of the flue pipe. Avoid air gaps between probe and measuring port to avoid inaccurate readings.
- ▶ Press On/Off button to turn heater On. For this test the unit has to be put in Service Level.
- ▶ Open a hot water tap.
- ▶ After 10 seconds, press and hold the reset button .
- ▶ Rotate the recirculating water temperature selector (left knob) to the minimum and then to maximum.
- ▶ Release the reset button and the display should show * (blinking).
- ▶ Rotate the hot water temperature selector  to the maximum.
- ▶ The restrictor size is correct if the CO₂ level is within the values as per table 14.

CO₂ value (%)
enter here: _____

Table 13

Appliance	CO ₂ (%)
GWH-345-ESR-N	6.8 - 7.2
GWH-345-ESR-L	7.5 - 8.0
GWH-450-ESR-N	6.5 - 7.0
GWH-450-ESR-L	7.0 - 7.5

Table 14 CO₂ levels at max. input

- ▶ If the CO₂ content is too high, use the next largest restrictor.
- ▶ After replacing the restrictor, measure CO₂ level again. Repeat procedure until correct level is obtained.

- ▶ Once correct reading is obtained, replace screw with gasket in exhaust collar.
- ▶ Press On/Off button to turn heater Off and exit Diagnostic Mode.

3.10 Water connections



- ▶ When facing the heater, the 3/4" NPT inlet is on the bottom right and the 3/4" NPT outlet is on the bottom left (Fig. 32). Install the heater centrally in the building if possible and make piping runs as short as possible.

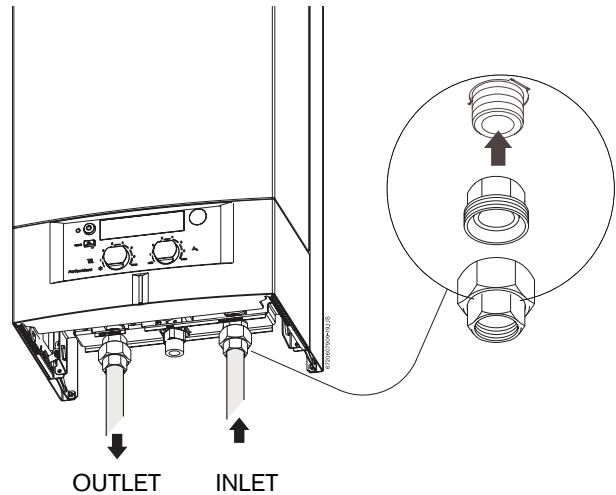

Fig. 32

- ▶ The use of unions when connecting both water pipes to the inlet and outlet connections is recommended. This will facilitate any necessary servicing.
- ▶ Although water piping throughout the building may be other than copper, we recommend that copper or suitably rated stainless steel flex line piping be used for the water connections for 3' on either side of the recirculating water heater (follow local codes if more stringent).
- ▶ Never sweat any rigid piping directly to or beneath the water connections, damage can occur to the internal heater components during the sweating process.
- ▶ Plastics or other PEX type plumbing line materials are not suitable for connecting directly to the water heater.
- ▶ Keep water inlet and outlet pipes to no less than 3/4" (19.05mm) diameter to allow the full flow capacity.
- ▶ If the cold and hot connections to the heater are reversed, the heater will not function correctly. Be certain there are no loose particles or dirt in the piping. Blow out or flush the lines before connecting to the water heater.
- ▶ Full port shut off valves should be installed on both the cold water supply and hot water outlet lines to facilitate servicing the heater (see Fig. 33).

Connecting the pressure relief valve (PRV)

The listed pressure relief valve supplied with the heater must be installed at the time of installation. No valve is to be placed between the PRV and the heater. No reducing coupling or other restriction may be installed in the discharge line. The discharge line must be a minimum of 4" above a drain and installed such that it allows complete drainage of both the PRV and the line. The location of the PRV must be readily accessible for servicing or replacement, and be mounted as close to the water heater as possible. See Fig. 33. To install the PRV, a suitable fitting connected to an extension on a "T" fitting can be sweated to the hot water line. Support all piping.

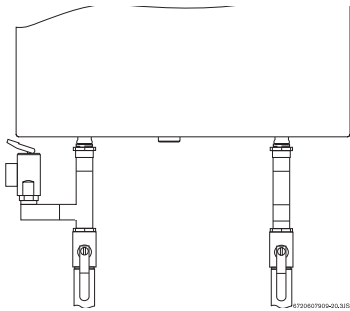

Fig. 33 Plumbing Connections and Pressure Relief Valve

3.11 Electrical connections



Warning: For safety reasons, disconnect the power supply to the heater before any service or testing is performed.



Warning: This heater must be electrically grounded in accordance with the most recent edition of the National Electrical Code, NFPA 70. In Canada, all electrical wiring to the heater must be in accordance with local codes and the Canadian Electrical Code, CSA C22.1 Part 1. Do not rely on the gas or water piping to ground the metal parts of the heater.

The GWH-345/450-ESR requires an electrical power supply from a 120VAC 60Hz circuit and must be properly grounded.

A means for switching off the 120VAC power supply must be provided.

The heater is wired as shown in the wiring diagram (chapter 4.8, Fig. 38).

4 Operating instructions

4.1 Initial filling instructions

Before proceeding with the operation of the heater make sure that the system is filled with water:

- ▶ Turn off power supply to heater.
- ▶ Open the cold water inlet supply to the heater fully.
- ▶ Open a hot water faucet to permit the water to fill the heater and the piping and to eliminate the air trapped in the system.
- ▶ Close the hot water faucet after the water flows freely and all the air has escaped from the system. Turn on power supply to heater. The water heater is now ready to operate.

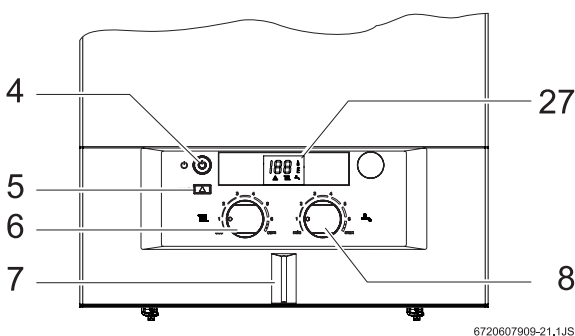

6720607909-21.1JS

Fig. 34

- 4 On/Off button
- 5 Reset button
- 6 Recirculation water temperature selector
- 7 LED - (ON) warning light (blinks during lock-out error)
- 8 Domestic hot water temperature selector
- 27 Digital display

4.2 For your safety read before operating your water heater



Warning: If you do not follow these instructions exactly, a fire or explosion may result causing property damage, personal injury or loss of life.

WHAT TO DO IF YOU SMELL GAS

- ▶ Do not try to operate any appliance.
- ▶ Do not touch any electric switch; do not use any phone in your building.
- ▶ Immediately call your gas supplier from a neighbors phone. Follow the gas supplier's instructions.
- ▶ If you cannot reach your gas supplier, call the fire department.

- ▶ Use only your hand to press the on/off control switch. Never use tools. Follow these instructions exactly. If control switch is jammed, close the gas supply and call a qualified service technician. Attempted forceful repair may result in a fire or explosion.
- ▶ Do not use this appliance if any part has been under water. Immediately call a qualified service technician to inspect the appliance and to replace any part of the control system and any gas control which has been under water.

4.3 Startup instructions

- ▶ **1. STOP!** Read the previous safety information.
- ▶ **2.** The gas valve must be shut off by putting the ON/OFF switch to position OFF. Wait five (5) minutes to clear out any gas. If you smell gas, STOP! Follow the safety information in Chapter 4.2 above. If you do not smell gas, go to the next step.
- ▶ **3.** This appliance is equipped with electronic ignition for lighting the main burners. When turning the heater on, follow these instructions exactly.
- ▶ **4.** Press the ON/OFF switch to the ON position. In this position, the water heater is ready to use.
- ▶ **5.** Connect tank Aquastat to the TT (thermostat) connection on the heater's printed circuit board. (Fig. 7, page 8). Close circuit on Aquastat to activate heater.
- ▶ **6.** The burners will remain on until the heat demand is met.



NOTE: upon installation or after gas line work has been done, air in the gas line may cause a lockout error. Reset the unit (Fig. 34, pos. 5). The heater will reattempt ignition.

When the heater is in operation you may hear its induced draft vent fan and burner operating. After a call for heat is satisfied, the fan will continue to operate for up to 5 seconds to exhaust all flue gases.



TO TURN OFF GAS TO APPLIANCE

- ▶ Turn off the manual gas shut off on the supply line to the heater and set the ON/OFF switch to the OFF position. Note: a manual gas shut off valve is not supplied with the heater.

4.4 Power

On

To start the appliance:

- ▶ press the ON/OFF  button.
LED (fig. 34) goes orange.
When the burner is working, the LCD display shows the symbol .

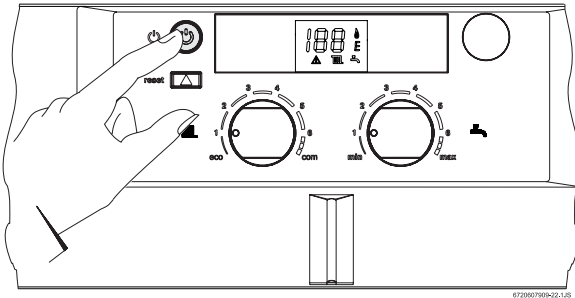

Fig. 35

Off



To shut down the appliance:

- ▶ press the ON/OFF  switch to OFF position.

4.5 Recirculating water temperature

Water temperature can be regulated in a range of 113°F to 194°F. The heater modulates the burner flame according to current demand selected on left knob.

To select water temperature:

- ▶ Rotate recirculating water temperature selector  in order to change heating recirculating temperature (ranging from 113°F to 194°F).
The display will show this symbol  and blink the selected temperature.
If the burner is on, symbol  goes ON.

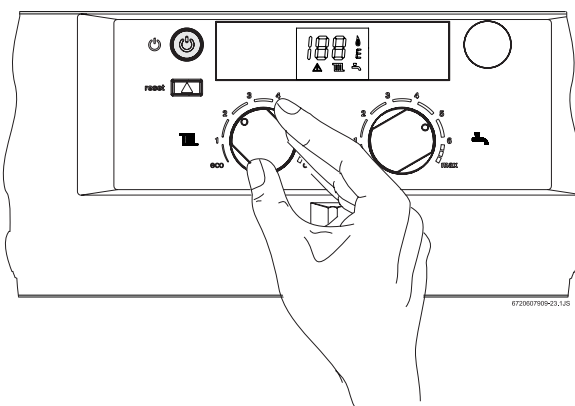



Fig. 36 Recirculating water temperature adjustment

4.6 Temperature and hot water flow

Choose one the following:

- If using a tank mounted Aquastat, set temperature on Aquastat control (left knob should be in maximum position).
- To activate and use the appliance domestic temperature dial, a 12 kOhm thermistor is required (part number 8 714 500 034) (See 2.6, Page 8 for wiring diagram).
- ▶ Connect the 12kOhm thermistor blue wire to the DHW NTC terminal block.
Install the sensor in the tank well.

Hot water temperature can be set from 50°F to 158°F using hot water temperature selector  (Fig. 37).

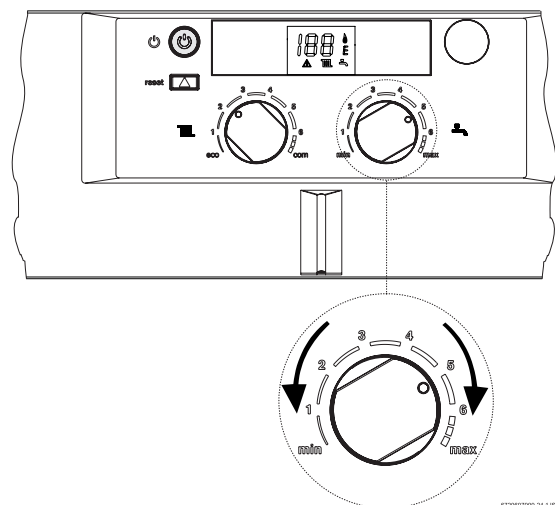

Fig. 37 Hot water temperature adjustment

Thermostat knob position	DHW temp.
Min.	approx. 50°F (10°C)
Max.	approx. 158°F (70°C)

Table 15 Domestic hot water temperature adjustment

4.7 Freeze protection

- ▶ Do not disconnect the electric supply from heater.
- ▶ Do not install in unheated areas which can experience freezing temperatures.
- ▶ Do not use non-potable additives like glycol.

Freeze protection

Freeze protection is always assured by the operation of the appliance.

If the primary NTC (temperature) sensor detects temperatures below 41°F, the appliance starts on minimum power until the sensor reads temperatures \geq 41°F.

4.8 Electrical diagram

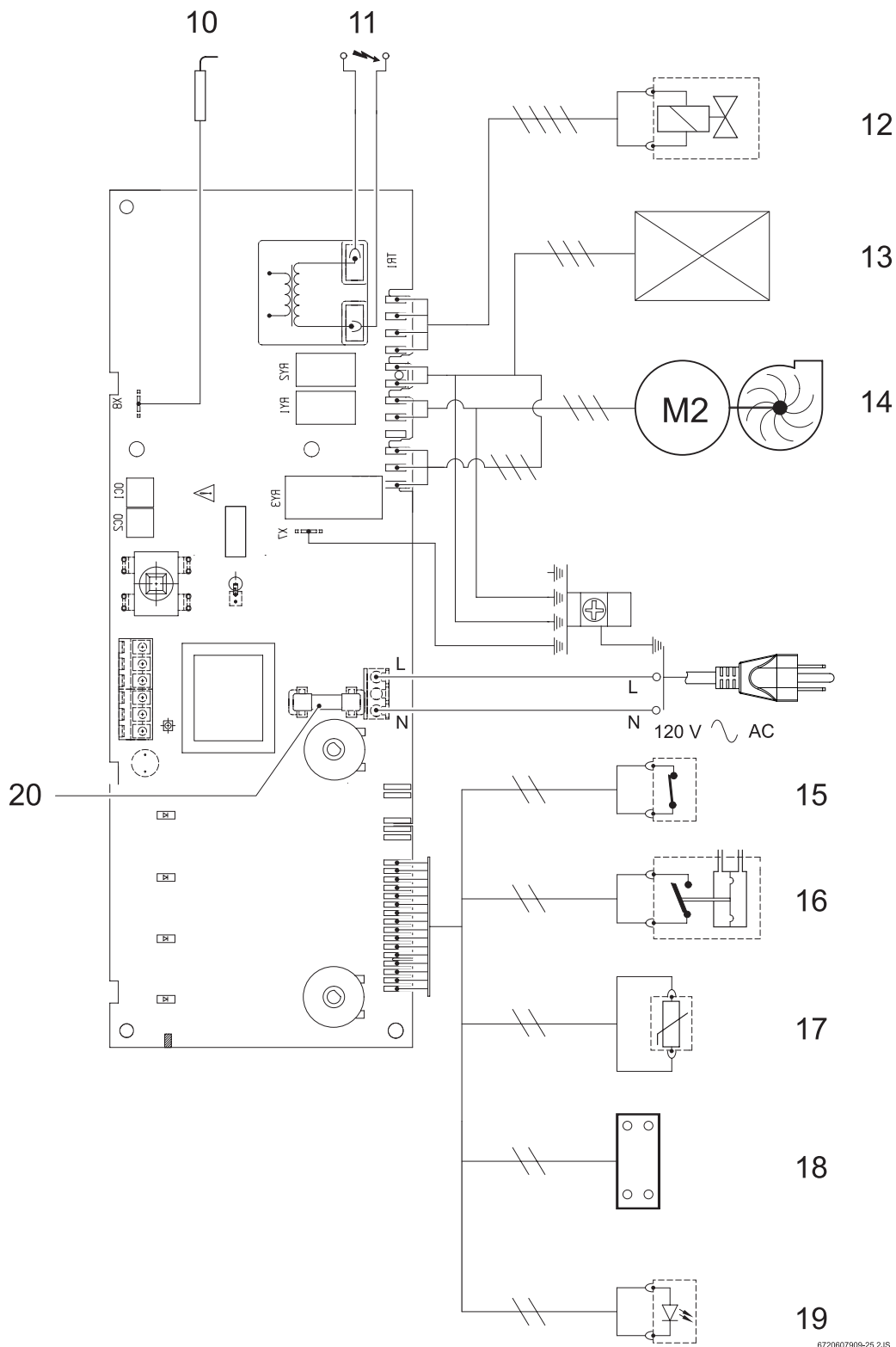

6720607909-26.2JS

Fig. 38 Electrical scheme

- 10 Flame sensor
- 11 Ignitor electrode
- 12 Gas valve
- 13 Junction box (wiring of tank pump)
- 14 Fan
- 15 Temperature limiter / ECO
- 16 Differential pressure switch
- 17 TT connection - under low voltage cover plastic

- 18 Domestic hot water temperature sensor (12kOhm only - under low voltage cover plastic)
- 19 LED
- 20 Fuse (3.15)

NOTICE: Except for the fuse, there are no serviceable parts inside the electronics.

5 Maintenance and service



Warning: Always turn off the electrical power supply, turn off the manual gas valve and turn off the manual water shut off valves whenever servicing.

The unit should be checked once a year by a gas technician. If repairs are needed, the repairs should be done by a gas technician

To remove front cover

- ▶ Loosen the two Philips head screws (as shown in Fig. 2).
- ▶ Pull control panel upwards and then pull it downwards.
- ▶ Lift front cover panel upward and remove.

Yearly maintenance



Refer to diagrams on pages 37 and 38.

- Inspect venting system for leaks, blockage or other damage
- Unclip 4 access clips and remove cover to inspect and clean burner assembly
- Manual operation of the pressure relief valve to insure correct operation
- If flow is reduced or error AA is activated, flush the heat exchanger with a descaling solution if mineral build up is evident. Scale build up will shorten the life of the water heater and is not covered by warranty. Descale heat exchanger thoroughly and repeat annually depending on mineral content of ground water.

5.1 Diagnostic mode

The Diagnostic Mode provides diagnostic information to the technician with a variety of real time parameters. See Table 16 for the parameters and their respective meaning.

Accessing the Diagnostic mode

- ▶ Switch on the equipment.
- ▶ Press and hold the reset button 
- ▶ Rotate the hot water temperature sensor dial  to the minimum and to the maximum.
Now the appliance is in the Diagnostic Mode.

Selecting parameter

- ▶ Rotate the recirculating water temperature selector (left dial)  to scan the different parameters.

Rotating clockwise accesses the next parameter (increasing).

Once the desired parameter number has been selected, the digital display will change to the value stored in that parameter.



Adjusting parameters

- ▶ Rotate hot water temperature selector dial  to change the value of the parameter (only parameter 03 and 22).

Mode	Parameter	Values
01	Not used	----- (displayed values have no relevance)
02	Not used	----- (displayed values have no relevance)
03	Error code history	Displays the last 8 error codes. Use the hot water temperature selector (right dial) to toggle from newest (left) to oldest (right) error codes.
04	Outlet water temperature	Displays the real-time outlet temperature as detected by the outlet temperature sensor.
05	Selected outlet water temperature	Displays the outlet water temperature as selected by the user during normal operation.
06	DHW temperature (only if 12kOhm thermistor used)	Displays the real-time temperature of the DHW tank as detected by the 12kOhm external thermistor. (Display will show 32 if thermistor not used)
07	Selected DHW temperature (only if 12kOhm thermistor used)	Displays the domestic hot water temperature as selected by the user (only if 12kOhm external thermistor used).
08	Not used	----- (displayed values have no relevance)
09	Pressure switch	00 - Open pressure switch - fan is off or there is no exhaust gas flow
		01 - Closed pressure switch - fan is on or there is exhaust gas flow
10	Temperature limiter	01 - temperature is below the limit (220°F)
		E9 - temperature is above the limit (220°F)
11	Not used	----- (displayed values have no relevance)
12	Gas valve	00 - gas valve closed
		01 - gas valve open
13	Modulating gas valve position (%)	00 - gas valve closed
		01-70 - gas valve position min/max
14	Thermostat	00 - thermostat open
		01 - thermostat closed
15	Fan	00 - fan off
		01 - fan on
16	Ionization	00 - no flame detected
		01 - flame detected
17	Not Used	----- (displayed values have no relevance)
18	Not Used	----- (displayed values have no relevance)
19	Not Used	----- (displayed values have no relevance)
20	Not Used	----- (displayed values have no relevance)
21	Digital display test	All LCD components appear
22	Temperature unit selection (°C or °F)	Use the hot water temperature selection knob to select temperature units °C or °F. (ccw for °C and cw for °F)

Table 16

Parameter storage

- ▶ Keep pressing the reset button  for at least 2 seconds in order to record adjustments. The digital display blinks with the symbol .

Exiting Diagnostic mode

- ▶ Press ON/OFF button to turn appliance OFF and then back ON again.



If the appliance is not powered off and then back on again, it returns to normal working conditions after 5 minutes.

6 Altitude adjustments

Above 4,000 feet, adjustment of air restrictor might be required.

- ▶ Install air restrictors according to tables 6, 7 and 8.

To reduce the natural derate, increase the gas manifold pressure and then check to ensure the CO₂ is within the limits in table 17.

Appliance	CO ₂ (%)
GWH-345-ESR-N	6.8 - 7.2
GWH-345-ESR-L	7.5 - 8.0
GWH-450-ESR-N	6.5 - 7.0
GWH-450-ESR-L	7.0 - 7.5

Table 17 CO₂ levels at max. input



Warning: do not exceed 9.5" W.C. for LP or 4.0" W.C. for NG at maximum input. Always test gas pressure and CO₂ in Diagnostic Mode.

7 Troubleshooting

Fault Indication	Possible Cause	Check
E9	Shut down by the temperature limiter (over 220°F temperature).	<ul style="list-style-type: none"> • 1. Check position of outlet water sensor. Ensure that sensor is firmly attached to outlet pipe • 2. Check temperature limiter, cables and connections • 3. Check system for air • 4. Purge air from system if detected.
EA	No Flame detected (no ignition).	<ul style="list-style-type: none"> • 1. Check for flame, ignition • 2. Check gas inlet pressure, gas type, air inside gas pipe • 3. Check manifold pressure for proper operation of the gas valve • 4. Check ionization sensor, cable • 5. Check control unit¹⁾ • 6. Check ignition wires and connections.
F7	"false flame" (error during self check of electronic).	<ul style="list-style-type: none"> • 1. Check for moisture on the Electronics • 2. Check cables, ionization sensor contacts (corrosion) • 3. Use diagnostic mode #12 to verify if gas valve is closed • 4. Check control unit¹⁾.
E0	Shut down because of low voltage.	<ul style="list-style-type: none"> • 1. Check for adequate power supply • 2. Check control unit for visible damage¹⁾.
F0	Internal error in the control unit.	<ul style="list-style-type: none"> • 1. Check control unit connections and wiring. • 2. Replace control unit.
C4	Fan not working	<ul style="list-style-type: none"> • 1. No power to fan, check for 120 volts at fan • 2. Check wire connections.
C6	Shut down by pressure switch.	<ul style="list-style-type: none"> • 1. Blocked vent • 2. Fresh air supply inadequate • 3. Silicone tubes from pressure switch to fan not connected or reversed. Black (top) clear (bottom). • 4. Check wire and connection.
E2	Outlet temperature sensor defect (no function)	<ul style="list-style-type: none"> • 1. Check sensor connection • 2. Check cable (opened, short) • 3. Check control unit¹⁾.
A7	Domestic hot water - Tank temperature sensor defect (no function)	<ul style="list-style-type: none"> • 1. Check <u>domestic hot water</u> sensor on tank for defects. Compare parameter value of mode #6 to actual tank water temperature • 2. Check cable (opened, short) • 3. Check control unit¹⁾.

Table 18

Fault Indication	Possible Cause	Check
AA	Flow reduced	<ul style="list-style-type: none"> • 1. Check heat exchanger - flush or descale if necessary.
LED or LCD of the appliance doesn't start up, no function.	No voltage supply, fuse blown, transformer etc. defect	<ul style="list-style-type: none"> • 1. Check voltage supply • 2. Check fuse • 3. Check control unit¹⁾.
Noise; boiling noise (over heating).	Low circulation, air inside installation, bad heat transfer.	<ul style="list-style-type: none"> • 1. Check for air in system, purge if detected • 2. Check circulators for proper operation • 3. Check heat exchanger for blockage or scale deposits • 4. Check gas type, injectors, gas valve • 5. Verify heater is not in service mode.
No heating function.	No heat demand by the thermostat, thermostat set too low, other defect.	<ul style="list-style-type: none"> • 1. Check thermostat position • 2. Check control unit¹⁾.
No DHW function.	No heat demand by the 12kohm thermistor or aquastat.	<ul style="list-style-type: none"> • 1. Check thermistor cable • 2. Check Domestic hot water thermistor or aquastat on tank • 3. Check control unit¹⁾.

Table 18

1) Check connections, fuse or if there are visible damages.

Error lock-out is indicated by the orange LCD blinking. An error lock-out is done for safety reasons. After fixing the problem, press the reset button to return the heater to service.

8 GWH-345/450-ESR Functional scheme

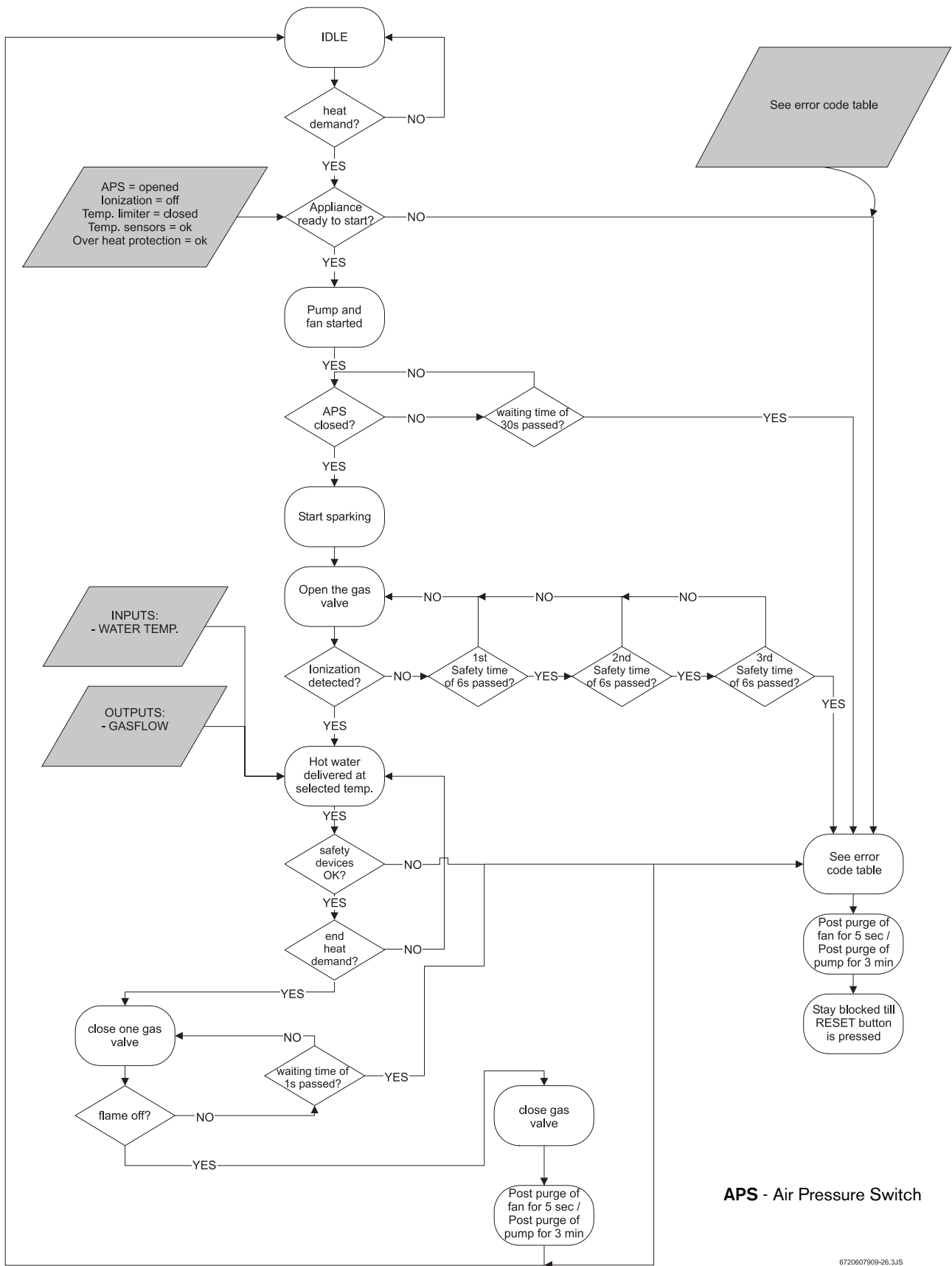

Fig. 39 Functional scheme

9 Interior components diagram and parts list

9.1 Interior components

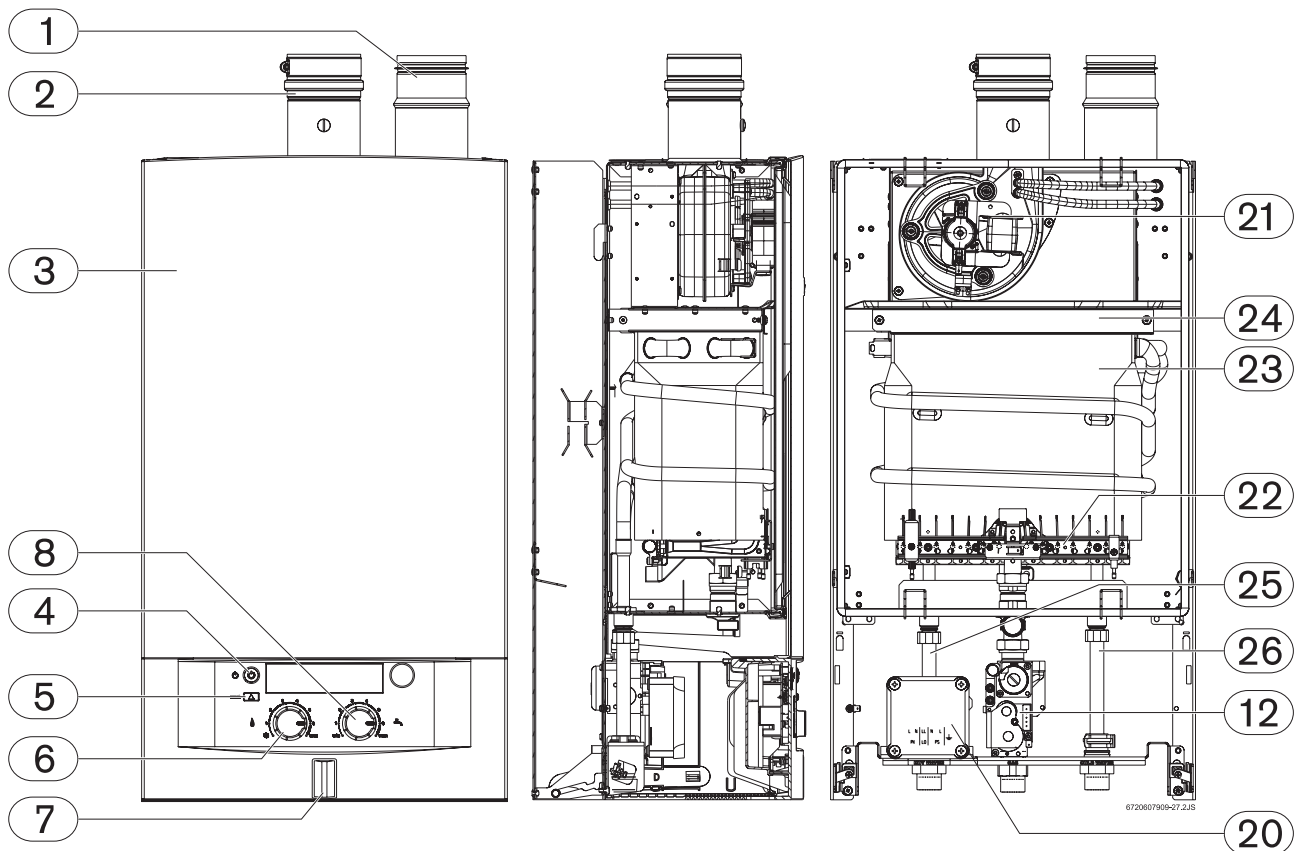

Fig. 40 Components

- | | |
|----|--|
| 1 | Combustion air inlet adapter (right side only) |
| 2 | Exhaust adapter with CO ₂ measuring point |
| 3 | Front cover |
| 4 | On/Off button |
| 5 | Reset button |
| 6 | Recirculation water temperature selector |
| 7 | LED - (ON) warning light (blinks when in lock out) |
| 8 | Domestic hot water temperature selector |
| 12 | Gas valve |
| 20 | Junction box |
| 21 | Centrifugal blower |
| 22 | Main burner |
| 23 | Heat exchanger |
| 24 | Holding bracket |
| 25 | Outlet water pipe |
| 26 | Inlet water pipe |

9.2 Components diagram

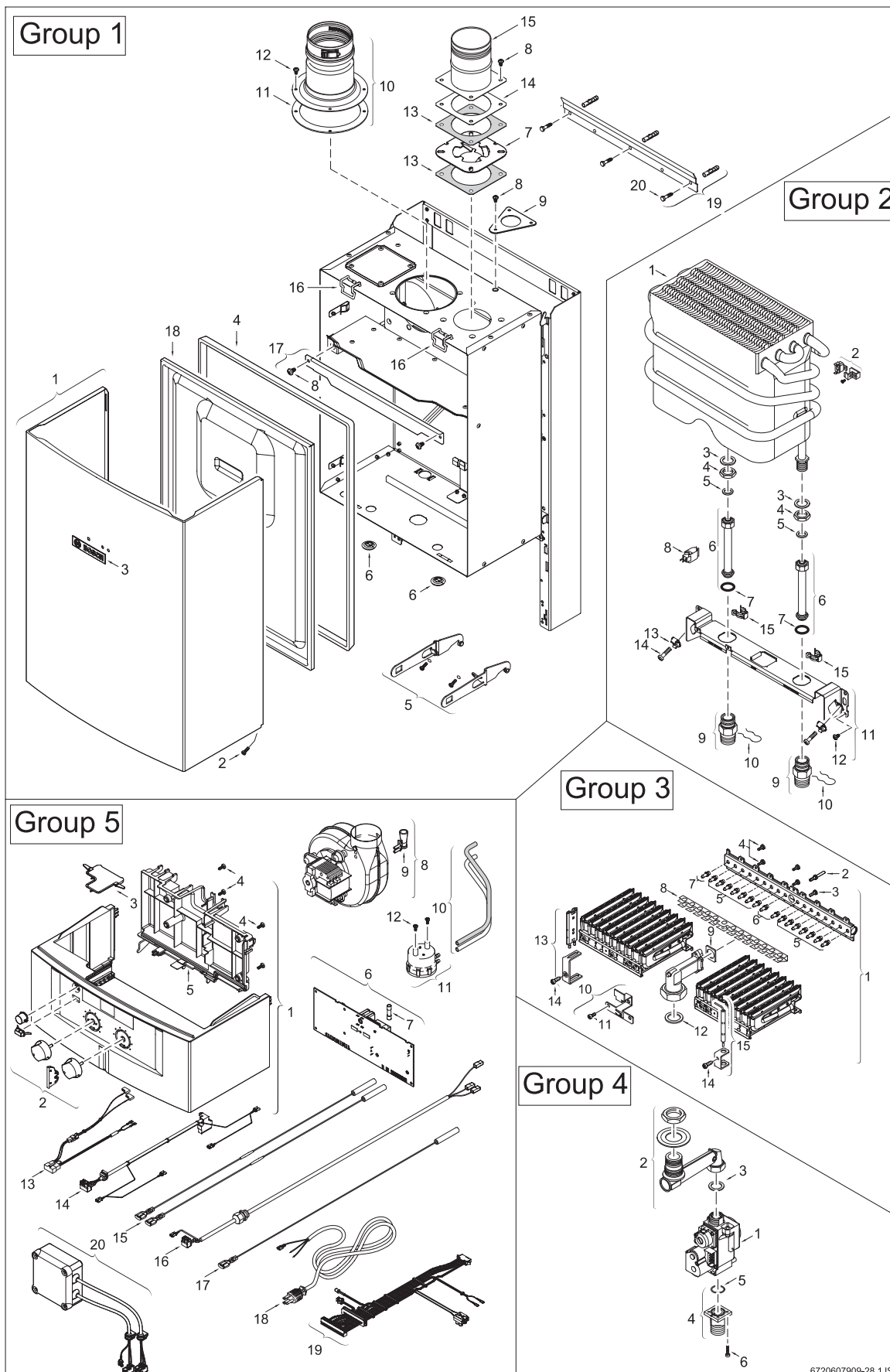

Fig. 41 Components Diagram

9.3 Parts list

Item	Description	Reference
GROUP 1		
1	Front cover	8 705 431 223
2	Cover screw no. 10 x 22mm	2 910 612 435
3	Trade mark badge	8 701 103 140
4	Gasket	8 704 701 077
5	Support set	8 708 006 130
6	Grommet set	8 710 203 039
7	Deflector plate	8 700 100 376
8	Screw M4,8 x 9,5mm	8 703 403 012
9	Angle bracket	8 708 003 218
10	Flue gas accessory	8 705 504 149
11	Washer	8 716 140 939
12	Screw 8x3/8" philips	2 910 612 424
13	Washer	8 711 004 022
14	Throttle disc set (GWH345ESR)	8 709 918 779
14	Throttle disc set (GWH450ESR NG)	8 709 918 780
14	Throttle disc set (GWH450ESR LP)	8 709 918 782
15	Combustion air accessory	8 705 504 148
16	Clip	8 701 201 032
17	Holding bracket (GWH345ESR)	8 701 302 099
17	Holding bracket (GWH450ESR)	8 701 302 235
18	Cover	8 701 302 225
19	Mounting bracket with screws	8 708 003 143
GROUP 2		
1	Heat exchanger (GWH345ESR)	8 705 406 374
1	Heat exchanger (GWH450ESR)	8 705 406 329
2	Temperature limiter/ECO 104°C	8 707 206 204
3	Washer 25OD X 21ID X 2MM	8 700 103 125
4	Locknut G 1/2"	8 713 300 018
5	Fiber washer 18.6x13.5x1.5	8 710 103 045
6	Cold water pipe	8 700 703 163
7	O-ring	8 700 205 135
8	Temperature sensor	8 700 400 015
9	Connection bush	8 703 305 326
10	Wireform spring	8 714 606 002
11	Mounting bracket	8 701 309 158
12	Screw	8 743 401 019
13	Cage nut	8 703 309 001
14	Screw M 5.0X20 DIN 7985	2 910 642 162
15	Clip	8 716 102 607
GROUP 3		
1	Main burner LP (GWH345ESR)	8 708 120 625
1	Main burner NG (GWH345ESR)	8 708 120 624
1	Main burner LP (GWH450ESR)	8 708 120 623
1	Main burner NG (GWH450ESR)	8 708 120 622

Table 19

Item	Description	Reference
2	Screw	8 703 404 089
3	Screw	8 703 401 069
4	Screw M4 x 12 phillips	2 910 952 122
9	Washer	8 701 003 010
10	Angle bracket	8 711 304 287
11	Screw	2 910 619 409
12	Washer 1"	8 710 103 060
13	Ignition electrode	8 708 107 008
14	Screw m3.5x6 phillips steel	2 910 642 082
15	Flame sensor	8 708 107 009
GROUP 4		
1	Gas valve	8 707 021 333
2	Connector	8 705 202 126
3	Washer- fibre 24OD X 16ID X 2MM	8 700 103 014
4	Connection bush	8 703 305 325
5	O-ring	8 700 205 144
6	Screw	2 912 601 120
GROUP 5		
1	Front cover	8 707 207 219
2	Selector knobs	8 702 000 309
3	Cover	8 705 400 069
4	Screw	8 703 403 074
5	Cover	8 705 400 056
6	Printed circuit board	8 708 300 193
7	Fuse T3, 15A	1 904 522 745
8	Centrifugal blower	8 707 204 061
9	Differential pressure line	8 703 305 302
10	Set of hose	8 700 703 049
11	Pressure differential switch (GWH345ESR)	8 707 406 007
11	Pressure differential switch (GWH450ESR)	8 707 406 094
12	Screw tapping no6 x 9.5	2 910 612 410
13	Cable	8 704 401 311
14	Cable	8 704 401 312
15	Set of cables	8 704 401 309
16	Cable	8 704 401 308
17	Set of cables	8 704 401 310
18	Power supply cord	8 704 401 267
19	PCB wire harness	8 704 401 295
20	Junction box	8 701 103 142

Table 19

10 Protecting the environment

Packing

The packing box may be fully recycled as confirmed by the recycling symbol .

Components

Many parts in the heater can be fully recycled in the end of the product life. Contact your city authorities for information about the disposal of recyclable products.

Saving water resources:

- ▶ Make sure you close all the taps after any use. Avoid leaving the taps dripping. Repair any leaking tap.
- ▶ Whenever possible use taps with built-in water flow limiters. They will give you the same comfort level while saving water.
- ▶ Set the water temperature to the desired temperature or slightly higher. Hotter water temperatures can result in scalding and wasted energy.

11 Ten Year Limited Warranty

General

BOSCH PRO water heaters are warranted by the Manufacturer. Bosch Thermotechnology Corp. will furnish a replacement heat exchanger and will furnish a replacement of any part which fails in normal use and service within the applicable periods specified below, in accordance with the terms of this warranty. The replacement will be warranted for the unexpired portion of the original warranty. This warranty will be valid only for water heaters in possession of the original purchaser as recorded on the warranty card.

The Heat Exchanger

If the heat exchanger fails within five (5) years after the original installation and operation, Bosch Thermotechnology Corp. will furnish a replacement heat exchanger at no charge. If the heat exchanger fails during years 6-10 after the original installation and operation, Bosch Thermotechnology Corp. will cover 50% of the cost of a replacement heat exchanger. However, if the water heater is installed in other than a single family dwelling, this heat exchanger replacement warranty is limited to two (2) years from date of original installation and operation.

Exceptions

This warranty will not apply:

- **1.** to defects or malfunctions resulting from failure to properly install, operate or maintain the unit in accordance with the printed instructions provided;
- **2.** to damage or abuse, accident, neglect or freezing and other acts of nature;
- **3.** to damage resulting from operation with either the flame sensor rod or overheat sensor removed;
- **4.** to failure of the heat exchanger resulting from the operation of the water heater in a corrosive atmosphere or at water temperatures exceeding the maximum rating, or if the water heater is not supplied with potable water;
- **5.** to defects or damage cause by any attachment or modification, including any energy-saving device.
- **6.** to damage resulting from scale deposits and/or highly mineralized / unsoftened water supply.

All Other Parts

If any other part fails within one (1) year after original installation and operation, Bosch Thermotechnology Corp. will furnish a replacement part free of charge.

Service Labor Costs

This warranty does not cover any labor costs associated with service, removal or re-installation of part(s). All such costs must be borne by the Purchaser. Additionally, this warranty does not cover any labor

costs associated with service, removal, installation or re-installation of the original water heater or a replaced water heater.



NOTE: the water heater must be free of damaging scale deposits and not subject to gas pressures greater than those shown on the rating plate, which must not be altered, defaced or removed.

How to Make a Claim

Any claim for warranty parts should be made to your local dealer or distributor.

In most cases, the dealer or distributor will be able to promptly honor your claim and subsequently notify Bosch Thermotechnology Corp.. However, all replacements are made subject to validation by Bosch Thermotechnology Corp. of in-warranty coverage. The damaged or defective item must be made available in exchange for the replacement.

Miscellaneous

No one is authorized to make any other warranties on behalf of Bosch Thermotechnology Corp.. It is expressly understood that the replacement warranty of Bosch Thermotechnology Corp. shall be in lieu of any and all other warranties, express or implied, including warranties of merchantability or fitness for a particular use or purpose, and further that Bosch Thermotechnology Corp. shall not be liable for any loss or damage directly or indirectly arising from the use of the hot water heater, or for any consequential damages arising from such use (including damages from water leakage). Bosch Thermotechnology Corp. sole liability with respect to any defect shall be for the replacement of the defective part(s). Some states do not allow such limitations and exclusions, so the above may not apply to you.

This warranty gives specific legal rights. You may also have other rights which vary from state to state.

Installer Checklist, to be performed by installer upon installation

Serial Number _____
(8 digit serial number is located on rating plate on right side panel)

Gas Pressure reading* Static _____ Operating _____

CO₂ reading _____

Air restrictor size _____

Building Water Pressure _____ Range if on Well system _____

Installing Company _____

Installer name _____

Address _____

Phone _____

* See Chapter 3.8 and gas pressure table (to be filled out by installer)

Installation manual should be left with the owner after the installation is tested and completed

BOSCH THERMOTECHNOLOGY CORPORATION

50 Wentworth Avenue
Londonderry, NH 03053
Tel. 866-330-2730
www.boschpro.com

Bosch Termotecnologia SA
Estrada de Cacia
3801 - 856 Aveiro - PORTUGAL