

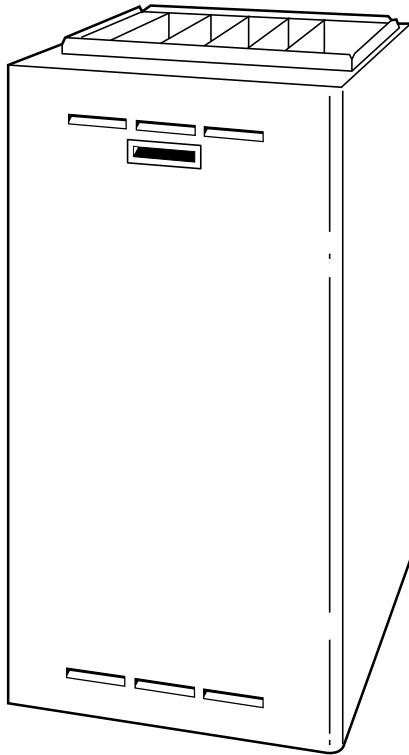

4-WAY MULTIPOISE FIXED-CAPACITY NON-DIRECT-VENT CONDENSING GAS FURNACE

345MAV

Sizes 040 thru 120
Series B



4-WAY MULTIPOISE CONDENSING GAS FURNACE

The model 345MAV Multipoise Condensing Furnace is specifically designed to meet the needs of the new construction market. This high-efficiency furnace utilizes a unique 4-way multipoise design and compact size to fit where other furnaces will not. The model 345MAV can be installed in any of 4 positions including horizontally in attics or crawlspaces, freeing space formerly used as a utility or furnace room. Sidewall or through-the-roof venting options and the use of PVC pipe eliminate the need for dedicated chimneys or chaseways to facilitate furnace venting. Time-saving installation features yield a very cost effective way to provide new home buyers with a high-efficiency and high-quality home comfort system.

FEATURES

4-Way Multipoise Design—Allows a model 345MAV to be installed in an upflow, downflow, or horizontal orientation.

The model 345MAV is available in 11 heat/airflow combinations and, when combined with the 4-way design, allows for 44 different application types. Factory configured for upflow application, this furnace can easily be made ready for downflow or horizontal installation.

Combustion System—Enclosed burner assembly isolates operating noise without the expense of sound deadening devices. This furnace uses combustion air from an area adjacent to the furnace and brings it in through a short section of inlet pipe that terminates just outside of the cabinet.

3-Pass Primary Heat Exchangers—This design accelerates heat transfer and extracts heat that conventional heat exchangers waste up the flue. The primary heat exchanger is made of aluminized steel for corrosion resistance.

Flow-Through Secondary Heat Exchangers—Each cell is laminated with our patented Everlastic™ polypropylene for greater resistance to corrosion. This breakthrough in heating technology helps extend the life of the furnace for years of dependable performance. The heat exchanger is positioned in the furnace to extract additional heat from the combustion products regardless of furnace orientation.

Warranty—The 345MAV is backed by a 20-year Limited Warranty on the heat exchangers and a 1-year Warranty on the microprocessor control and hot surface ignitor.

Monoport Inshot Burners—Produce precise air-to-gas mixture which gives a clean burn. The large monoport on the inshot or injection-type burners seldom, if ever, needs cleaning.

Integrated Control Center—The printed-circuit board and all internal wiring are factory installed. Convenient terminals permit quick-connection of a thermostat, and air conditioning control circuits. Connections for a humidifier and air cleaner are also provided.

The control has a built-in status indicator and self-test feature. The status indicator flashes to indicate a problem condition and assists the servicer in diagnosis. The self-test feature allows for a complete check of the major components in only seconds.

Combustion Air and Ventilation—The 345MAV advanced design allows Schedule 40PVC, PVC-DWV, SDR-21 PVC, SDR-26 PVC (not approved in Canada), ABS-DWV, or ABS-F628 Schedule 40 pipe to bring air into the furnace for combustion. The extracted heat lowers the temperature of the combustion products to a point (typically below 115°F) that any of the approved types of pipe can also be used for venting combustion products outside the structure. The vent pipe can terminate through a sidewall or through the roof.

Insulated Casing—Foil-faced insulation in the heat exchanger section cuts heat loss. The casing also has the required openings for left- or right-side connection of gas, electric, drain, and vent connections.

Certifications—The 345MAV units are A.G.A. and C.G.A. design certified for use with natural and propane gases, as well as GAMA efficiency rating certified. The furnace is factory-shipped for use with natural gas. An A.G.A./C.G.A. certified gas conversion kit is required to convert furnace for use with propane gas. The model 345MAV meets California Air Quality Management District emission requirements.

CONDENSATE TRAP

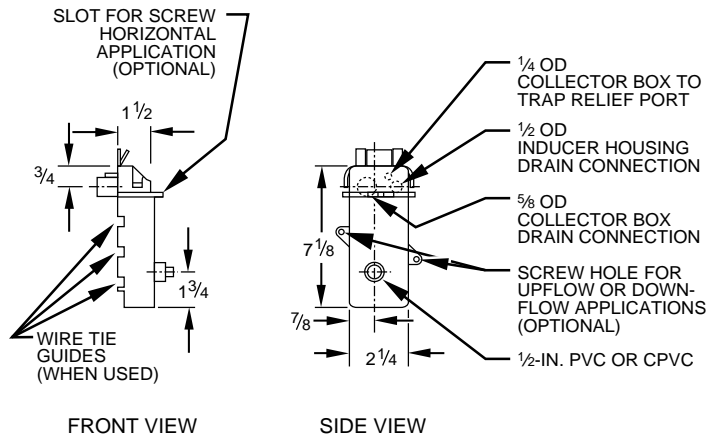
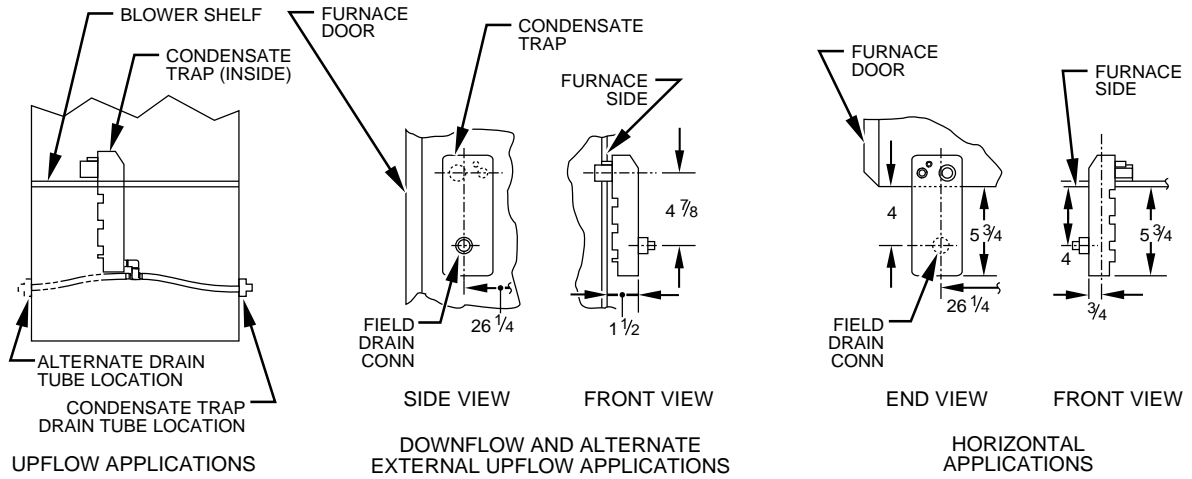

A93026



MEETS DOE RESIDENTIAL CONSERVATION SERVICES PROGRAM STANDARDS.

Before purchasing this appliance, read important energy cost and efficiency information available from your retailer.



APPROVALS
 ISO 9001
 EN 29001
 BS 5750 PART 1
 ANSI/ASQC Q91

As an ENERGY STAR Partner, Bryant Heating & Cooling Systems has determined that this product meets the ENERGY STAR guidelines for energy efficiency.

REGISTERED QUALITY SYSTEM

SPECIFICATIONS

UNIT SIZE	024040	036040	024060	036060	048060
RATINGS AND PERFORMANCE					
Input Btuh*	40,000	40,000	60,000	60,000	60,000
Output Capacity†	Nonweatherized ICS		37,000	37,000	55,000
AFUE%†	Nonweatherized ICS		90.0	90.0	90.0
Certified Temperature Rise Range (°F)	30—60	15—45	45—75	30—60	20—50
Certified External Static Pressure	Heating	0.10	0.10	0.12	0.12
	Cooling	0.50	0.50	0.50	0.50
Airflow CFM‡	Heating	850	1125	885	1065
	Cooling	895	1215	900	1200
ELECTRICAL					
Unit Volts—Hertz—Phase	115—60—1				
Operating Voltage Range Min—Max**	104—127				
Maximum Unit Amps	6.1	7.3	6.1	7.1	9.5
Unit Ampacity††	8.4	10.0	8.4	9.8	12.8
Minimum Wire Size	14	14	14	14	14
Maximum Wire Length (Ft)‡‡	44	37	44	38	29
Maximum Fuse Size or Ckt Bkr Amps***	15	15	15	15	15
Transformer (24v)	40va				
External Control Power Available	Heating	12va			
	Cooling	21va			
Air Conditioning Blower Relay	Standard				
CONTROLS					
Limit Control	SPST				
Heating Blower Control (Off Delay)	Factory-Set at 135 Sec				
Burners (Monoport)	2	2	3	3	3
Gas Connection Size	1/2-in. NPT				
GAS CONTROLS					
Gas Valve (Redundant)	Manufacturer	White-Rodgers			
	Min Inlet Pressure (In. wc)	4.5 (Natural Gas)			
	Max Inlet Pressure (In. wc)	13.6 (Natural Gas)			
Ignition Device	Hot Surface				
BLOWER DATA					
Direct-Drive Motor HP (PSC)	1/5	1/3	1/5	1/3	1/2
Motor Full Load Amps	4.9	5.8	4.9	5.8	7.9
RPM (Nominal)—Speeds	1075—3	1075—4	1075—3	1075—4	
Blower Wheel Diameter x Width (In.)	10 x 6	10 x 7	10 x 6	10 x 7	11 x 8
Filter Size (In.)—Permanent Washable	(1) 16 x 25 x 1				
FACTORY-AUTHORIZED AND LISTED, DEALER-INSTALLED OPTIONS					
Electronic Air Cleaner	Model 901KAX				
Humidifier	Models 912D, 912E, 913B, 913C, and 914A				
Twinning Kit†††	N/A				KGATW0401HSI
Side Filter Rack (Without Filter)†††	KGAFR0206ALL				
Return Filter Plenum (With Washable Filters)†††	KGARP0201ALL				
Condensate Freeze Protection Kit	KAHT0101CFP				
Downflow Base (For Combustible Floors With or Without A/C Coil)	KGASB0201ALL				
Gas Conversion Kit—Natural-to-Propane	KGANP2001ALL				
Gas Conversion Kit—Propane-to-Natural	KGAPN1601ALL				

See notes on page 5.

SPECIFICATIONS Continued

UNIT SIZE		036080	048080	060080	048100	060100	060120
RATINGS AND PERFORMANCE							
Input Btuh*		80,000	80,000	80,000	100,000	100,000	120,000
Output Capacity†	Nonweatherized ICS	74,000	74,000	74,000	92,000	92,000	111,000
AFUE%†	Nonweatherized ICS	90.0	90.0	90.0	90.0	90.0	90.0
Certified Temperature Rise Range (°F)		40—70	30—60	20—50	45—75	30—60	40—70
Certified External Static Pressure	Heating	0.15	0.15	0.15	0.20	0.20	0.20
	Cooling	0.50	0.50	0.50	0.50	0.50	0.50
Airflow CFM‡	Heating	1190	1285	1785	1315	1690	1720
	Cooling	1245	1525	1925/2035	1570	1930/2130	2000/2130
ELECTRICAL							
Unit Volts—Hertz—Phase		115—60—1					
Operating Voltage Range Min—Max**		104—127					
Maximum Unit Amps		7.6	10.0	14.1	10.2	14.8	14.6
Unit Ampacity††		10.4	13.4	18.4	13.5	19.3	19.1
Minimum Wire Size		14	14	12	14	12	12
Maximum Wire Length (Ft)‡‡		36	28	31	27	30	30
Maximum Fuse Size or Ckt Bkr Amps***		15	20	15	20	20	
Transformer (24v)		40va					
External Control Power Available	Heating	12va					
	Cooling	21va					
Air Conditioning Blower Relay		Standard					
CONTROLS							
Limit Control		SPST					
Heating Blower Control (Off Delay)		Factory-Set at 135 Sec					
Burners (Monoport)		4	4	4	5	5	6
Gas Connection Size		1/2-in. NPT					
GAS CONTROLS							
Gas Valve (Redundant)	Manufacturer	White-Rodgers					
	Min Inlet Pressure (In. wc)	4.5 (Natural Gas)					
	Max Inlet Pressure (In. wc)	13.6 (Natural Gas)					
Ignition Device		Hot Surface					
BLOWER DATA							
Direct-Drive Motor HP (PSC)		1/3	1/2	3/4	1/2	3/4	3/4
Motor Full Load Amps		5.8	7.9	11.1	7.9	11.1	11.1
RPM (Nominal)—Speeds		1075—4					
Blower Wheel Diameter x Width (In.)		10 x 7	11 x 8	11 x 10	11 x 8	11 x 10	11 x 10
Filter Size (In.)—Permanent Washable		(1) 20 x 25 x 1					(2) 16 x 25 x 1
FACTORY-AUTHORIZED AND LISTED, DEALER-INSTALLED OPTIONS							
Electronic Air Cleaner		Model 901KAX					
Humidifier		Models 912D, 912E, 913B, 913C, and 914A					
Twinning Kit†††	N/A	KGATW0401HSI					
Side Filter Rack (Without Filter)†††		KGAFR0206ALL					
Return Filter Plenum (With Washable Filters)†††		KGARP0201ALL					
Condensate Freeze Protection Kit		KGAHT0101CFP					
Downflow Base (For Combustible Floors With or Without A/C Coil)		KGASB0201ALL					
Gas Conversion Kit—Natural-to-Propane		KGANP2001ALL					
Gas Conversion Kit—Propane-to-Natural		KGAPN1601ALL					

* Gas input ratings are certified for elevations to 2000 ft. For elevations above 2000 ft, reduce ratings 2% for each 1000 ft above sea level. In Canada, derate the unit 5% for elevations 2000 to 4500 ft above sea level.

† Capacity and AFUE in accordance with U.S. Government DOE test procedures.

‡ Air delivery above 1800 CFM requires that both sides, a combination of 1 side and bottom, or bottom only of the furnace be used for return air. Where 2 sets of data are listed, the first set is for bottom only return-air supply. The second set is for both sides, or 1 side and bottom return-air supply. A filter is required for each return-air supply.

** Permissible voltage limits for proper furnace operation.

†† Unit ampacity = 125% of largest component's full load amps plus 100% of all other potential operating components' (EAC, humidifier, etc.) full load amps.

‡‡ Length shown is measured 1 way along wire path between unit and service panel for maximum 2% voltage drop.

*** Time-delay type is recommended.

††† Upflow application ONLY. See kit Installation Instructions for details.

N/A—Not applicable

ICS—Isolated Combustion System

PSC—Permanent Split Capacitor

VENT PIPING

MAXIMUM ALLOWABLE VENT PIPE LENGTH (FT)

ALTITUDE ABOVE SEA LEVEL (FT)	UNIT SIZE	VENT PIPE DIA (IN.)	NUMBER OF 90° ELBOWS						
			1	2	3	4	5	6	
0 to 2000	024040 036040	1	5	NA	NA	NA	NA	NA	
		1-1/2	70	70	65	60	60	55	
		2	70	70	70	70	70	70	
	024060 036060 048060	1-1/2	20	15	10	5	NA	NA	
		2	70	70	70	70	70	70	
		1-1/2	10	NA	NA	NA	NA	NA	
	036080 048080 060080	2	55	50	35	30	30	20	
		2-1/2	70	70	70	70	70	70	
		2	5	NA	NA	NA	NA	NA	
	048100 060100	2-1/2	40	30	20	20	10	NA	
		3	70	70	70	70	70	70	
		2-1/2	10	NA	NA	NA	NA	NA	
060120	3*	70	70	70	70	70	70		
2001 to 3000	024040 036040	1-1/2	67	62	57	52	52	47	
		2	70	70	70	70	70	70	
		1-1/2	17	12	7	NA	NA	NA	
	024060 036060 048060	2	70	67	66	61	61	61	
		2	49	44	30	25	25	15	
		2-1/2	70	70	70	70	70	70	
	048100 060100	2-1/2	35	26	16	16	6	NA	
		3	70	70	70	70	66	61	
		3*	63	62	62	61	61	61	
	3001 to 4000	024040 036040	1-1/2	64	59	54	49	48	43
			2	70	70	70	70	70	70
			1-1/2	16	11	6	NA	NA	NA
024060 036060 048060		2	68	63	62	57	57	56	
		2	46	41	28	23	22	13	
		2-1/2	70	70	70	70	70	70	
036080 048080 060080		2-1/2	33	24	15	14	5	NA	
		3	70	70	70	66	61	56	
		3*	59	59	58	57	57	56	
4001 to 5000†		024040 036040	1-1/2	60	55	50	45	44	39
			2	70	70	70	70	70	70
			1-1/2	15	10	5	NA	NA	NA
	024060 036060 048060	2	64	59	58	53	52	52	
		2	44	39	26	21	20	11	
		2-1/2	70	70	70	70	70	70	
	036080 048080 060080	2-1/2	31	22	13	12	NA	NA	
		3	70	70	67	62	57	52	
		3*	56	55	54	53	52	52	
	5001 to 6000†	024040 036040	1-1/2	57	52	47	42	40	35
			2	70	70	70	70	70	70
			1-1/2	14	9	NA	NA	NA	NA
024060 036060 048060		2	60	55	54	49	48	47	
		2	41	36	23	18	17	8	
		2-1/2	70	70	70	70	70	70	
036080 048080 060080		2-1/2	29	21	12	11	NA	NA	
		3	70	67	62	57	52	47	
		3*	53	52	50	49	48	47	

See notes on page 7.

MAXIMUM ALLOWABLE VENT PIPE LENGTH (FT) Continued

ALTITUDE ABOVE SEA LEVEL (FT)	UNIT SIZE	VENT PIPE DIA (IN.)	NUMBER OF 90° ELBOWS					
			1	2	3	4	5	6
6001 to 7000†	024040 036040	1-1/2	53	48	43	38	37	32
		2	70	70	68	67	66	64
	024060 036060 048060	1-1/2	13	8	NA	NA	NA	NA
		2	57	52	50	45	44	43
	036080 048080 060080	2	38	33	21	16	15	6
		2-1/2	70	70	68	67	66	64
	048100 060100	2-1/2	27	19	10	9	NA	NA
		3	68	63	58	53	48	43
060120	3*	49	48	47	45	44	43	
7001 to 8000†	024040 036040	1-1/2	49	44	39	34	33	28
		2	66	65	63	62	60	59
	024060 036060 048060	1-1/2	12	7	NA	NA	NA	NA
		2	53	48	46	41	40	38
	036080 048080 060080	2	36	31	19	14	12	NA
		2-1/2	66	65	63	62	60	59
	048100 060100	2-1/2	25	17	8	7	NA	NA
		3	63	58	53	48	43	38
060120	3*	46	44	43	41	40	38	
8001 to 9000†	024040 036040	1-1/2	46	41	36	31	29	24
		2	62	60	58	56	55	53
	024060 036060 048060	1-1/2	11	6	NA	NA	NA	NA
		2	49	44	42	37	35	34
	036080 048080 060080	2	33	28	17	12	10	NA
		2-1/2	62	60	58	56	55	53
	048100 060100	2-1/2	23	15	7	5	NA	NA
		3	59	54	49	44	39	34
060120	3*	43	41	39	37	35	34	
9001 to 10,000†	024040 036040	1-1/2	42	37	32	27	25	20
		2	57	55	53	51	49	47
	024060 036060 048060	2	45	40	38	33	31	29
		2	30	25	14	9	7	NA
	036080 048080 060080	2-1/2	57	55	53	51	49	47
		2-1/2	21	13	5	NA	NA	NA
	048100 060100	3	54	49	44	39	34	29
		3*	39	37	35	33	31	29

* Wide radius elbow.

† Vent sizing for Canadian installations above 4500 ft (1370m) above sea level are subject to acceptance by the local authorities having jurisdiction.

NA — Not Allowed; pressure switch will not make.

NOTES:

1. Do not use pipe size greater than those specified in table or incomplete combustion, flame disturbance, or flame sense lockout may occur.
2. Assume two 45° elbows equal one 90° elbow. Long radius elbows are desirable and may be required in some cases.
3. Elbows and pipe sections within the furnace casing and at the vent termination should not be included in vent length or elbow count.
4. The minimum pipe length is 5 ft for all applications.

**MAXIMUM ALLOWABLE EXPOSED VENT PIPE LENGTH (FT) WITH INSULATION
IN WINTER DESIGN TEMPERATURE AMBIENT***

UNIT SIZE	WINTER DESIGN TEMP °F	MAXIMUM PIPE DIA (IN.)	INSULATION THICKNESS (IN.)†				
			0	3/8	1/2	3/4	1
024040 036040	20	1-1/2	31	56	63	70	70
	0	1-1/2	16	34	39	47	54
	20	1-1/2	9	23	27	34	39
024060 036060 048060	20	2	45	70	70	70	70
	0	2	25	51	58	70	70
	20	2	16	36	42	51	60
036080 048080 060080	20	2-1/2	55	70	70	70	70
	0	2-1/2	31	61	69	70	70
	20	2-1/2	20	43	49	61	70
048100 060100	20	3	61	70	70	70	70
	0	3	33	65	70	70	70
	20	3	20	45	52	65	70
060120	20	3	70	70	70	70	70
	0	3	40	70	70	70	70
	20	3	26	55	64	70	70

* Pipe length (ft) specified for maximum vent pipe lengths located in unconditioned spaces. Vent pipes located in unconditioned space cannot exceed the total allowable pipe length as specified in Maximum Allowable Pipe Length table.

† Insulation thickness based on R value of 3.5 per in.

This forced air furnace is equipped for use with natural gas at altitudes 0 - 10,000 ft (0 - 3,050m), except 140 size Furnaces are only approved for altitudes 0 - 7,000 ft. (0 - 2,135m).

An accessory kit, supplied by the manufacturer, shall be used to convert to propane gas use or may be required for some natural gas applications.

This furnace is for indoor installation in a building constructed on site. This furnace may be installed in a manufactured (mobile) home when stated on rating plate and using factory authorized kit.

This furnace may be installed on combustible flooring in alcove or closet at minimum clearance from combustible material.

This appliance requires a special venting system. Refer to the installation instructions for parts list and method of installation. This furnace is for use with schedule-40 PVC, PVC-DWV, or ABS-DWV pipe, and must not be vented in common with other gas-fired appliances. Construction through which vent/air intake pipes may be installed is maximum 24 inches (600 mm), minimum 3/4 inches (19 mm) thickness (including roofing materials).

MINIMUM INCHES CLEARANCE TO COMBUSTIBLE CONSTRUCTION

ALL POSITIONS:

* Minimum front clearance for service 30 inches (762mm).

†† 140 size furnaces require 1 inch back clearance to combustible materials.

DOWNFLOW POSITIONS:

† For installation on combustible floors only when installed on special base No. KGASB0201ALL, Coil Assembly, Part No. CD5 or CK5, or Coil Casing, Part No. KCAKC.

HORIZONTAL POSITIONS:

§ Clearance shown is for air inlet and air outlet end.

Line contact is permissible only between lines formed by intersections of top and two sides of furnace jacket, and building joists, studs, or framing.

∅ 120 and 140 size Furnaces require 1 inch bottom clearance to combustible materials.

323857-101 REV. C (LIT)

This furnace is approved for UPFLOW, DOWNFLOW and HORIZONTAL installations.

Clearance arrows do not change with furnace orientation.

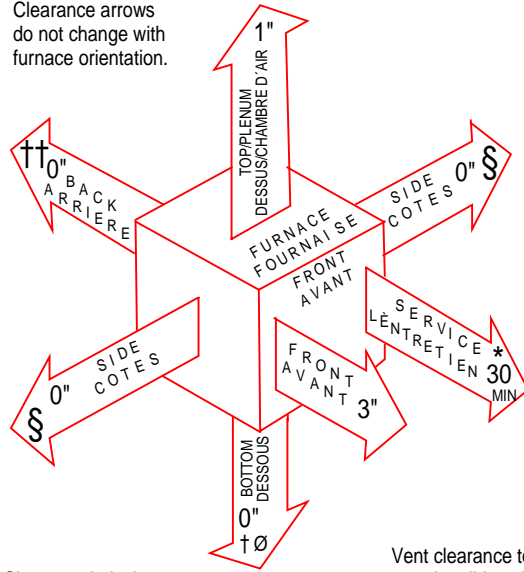

Clearance in inches

Vent clearance to combustibles 0".

ACCESSORIES

RETURN FILTER PLENUM*

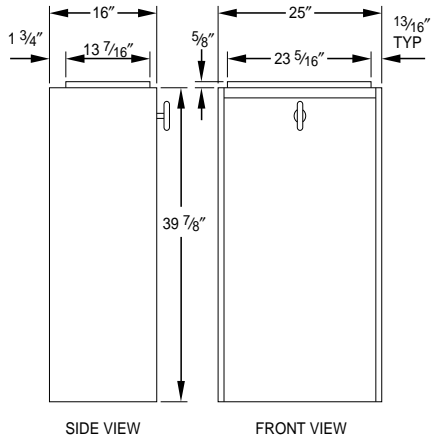

A93078

*Includes two 20 x 25 x 1 in. washable filters.

SIDE FILTER RACK*

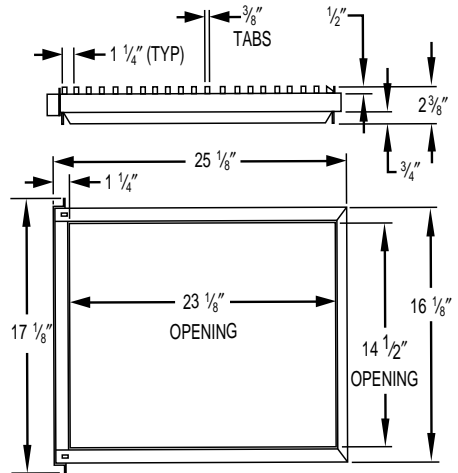

A80199

*Accepts one 16 x 25 x 1 in. filter.

AIR DELIVERY—CFM (With Filter)*

UNIT SIZE	RETURN-AIR SUPPLY	SPEED	EXTERNAL STATIC PRESSURE (In. wc)							
			0.1	0.2	0.3	0.4	0.5	0.6	0.7	0.8
024040	1 side or bottom	High	1075	1040	995	945	895	840	760	670
		Med-Low	850	825	780	740	685	635	560	480
		Low	740	700	650	620	565	515	455	385
036040	1 side or bottom	High	1470	1415	1400	1285	1215	1120	995	890
		Med-High	1315	1280	1235	1180	1115	1035	930	825
		Med-Low	1125	1110	1085	1045	990	915	830	740
024060	1 side or bottom	High	1100	1065	1005	945	900	805	730	610
		Med-Low	890	865	810	765	705	620	540	475
		Low	745	710	670	625	565	505	425	360
036060	1 side or bottom	High	1430	1375	1325	1275	1200	1135	1040	935
		Med-High	1270	1260	1215	1160	1105	1035	950	850
		Med-Low	1070	1055	1045	1015	975	920	850	750
048060	1 side or bottom	High	1700	1695	1640	1580	1545	1450	1380	1310
		Med-High	1500	1465	1435	1385	1355	1300	1250	1185
		Med-Low	1325	1295	1265	1230	1190	1150	1105	1050
048080	1 side or bottom	High	1750	1685	1635	1575	1525	1445	1380	1310
		Med-High	1495	1455	1405	1355	1305	1250	1185	1120
		Med-Low	1310	1260	1225	1170	1125	1095	1040	980
060080	bottom only	High	2200	2175	2085	2025	1925	1820	1735	1635
		Med-High	2100	2025	1945	1865	1785	1700	1620	1540
		Med-Low	1815	1760	1720	1670	1620	1550	1480	1405
048100	1 side or bottom	High	2360	2280	2210	2130	2035	1960	1875	1790
		Med-High	1965	1925	1870	1830	1760	1710	1670	1575
		Low	1560	1555	1515	1460	1435	1390	1340	1270
060100	bottom only	High	2250	2175	2090	2020	1930	1855	1760	1670
		Med-High	2020	1950	1900	1840	1790	1710	1640	1545
		Med-Low	1725	1690	1660	1630	1575	1520	1460	1370
060120	bottom only	High	2360	2315	2265	2200	2130	2055	1965	1890
		Med-High	1960	1940	1930	1900	1850	1800	1740	1660
		Low	1490	1480	1460	1440	1380	1340	1295	1230
060120	both sides or 1 side and bottom	High	2350	2250	2160	2070	2000	1885	1790	1635
		Med-High	2100	2015	1955	1875	1810	1710	1650	1540
		Med-Low	1770	1720	1675	1620	1575	1515	1450	1365
060120	both sides or 1 side and bottom	High	2435	2360	2285	2220	2130	2050	1965	1875
		Med-High	2040	2000	1950	1905	1835	1790	1725	1650
		Low	1545	1520	1465	1415	1365	1325	1265	1185

* Air delivery above 1800 CFM requires that both sides, a combination of 1 side and bottom, or bottom only of the furnace be used for return air. A filter is required for each return-air supply.

SERVICE TRAINING

Packaged Service Training programs are an excellent way to increase your knowledge of the equipment discussed in this manual, including:

- Unit Familiarization
- Maintenance
- Installation Overview
- Operating Sequence

A large selection of product, theory, and skills programs is available, using popular video-based formats and materials. All include video and/or slides, plus companion book.

Classroom Service Training plus "hands-on" the products in our labs can mean increased confidence that really pays dividends in faster troubleshooting, fewer callbacks. Course descriptions and schedules are in our catalog.

CALL FOR FREE CATALOG 1-800-962-9212

Packaged Service Training

Classroom Service Training

A94328

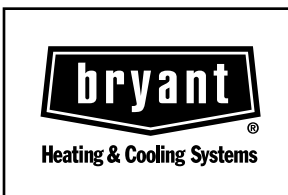

SPECIFICATIONS SUBJECT TO CHANGE WITHOUT NOTICE

UNIT MUST BE INSTALLED IN ACCORDANCE
WITH INSTALLATION INSTRUCTIONS

Cancels: 345M.40.1B