

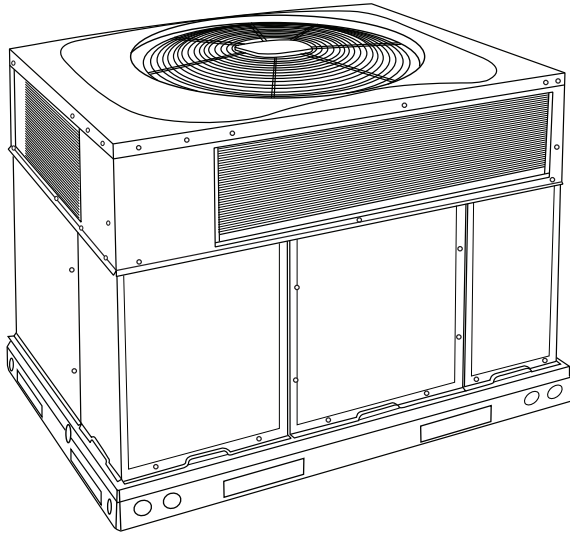

PH3G--A SINGLE PACKAGED HEAT PUMP SYSTEM WITH R-410A REFRIGERANT SINGLE AND THREE PHASE 2 - 5 NOMINAL TONS (SIZES 24-60)

Product Data



A09183

Fig. 1 - Unit PH3G--A

Single-Packaged Products with Energy-Saving Features and R-410A refrigerant.

- Up to 13.5 SEER
- Up to 7.7 HSPF
- Up to 11.5 EER at 95°F OD
- Factory-Installed TXV
- Multi-Speed High Efficiency DC Blower-Standard
- Dehumidification Feature

FEATURES/BENEFITS

One-piece Heat Pump unit with optional electric heater, low installation cost, dependable performance and easy maintenance.

Efficient operation High-efficiency design with SEERs (Seasonal Energy Efficiency Ratio) of up to 13.5.

Easy Installation

Factory-assembled package is a compact, fully self-contained, heat pump unit that is prewired, pre-piped, and pre-charged for minimum installation expense. These units are available in a variety of standard capacity ranges with voltage options to meet residential and light commercial requirements. Units are lightweight and install easily on a rooftop or at ground level. The high tech composite base eliminates rust problems associated with ground level applications.

Innovative Unit Base Design

On the inside a high-tech composite material will not rust and incorporates a sloped drain pan which improves drainage and helps inhibit mold, algae and bacterial growth. On the outside metal base rails provide added stability as well as easier handling and rigging.

Durable, dependable components Compressors are designed for high efficiency. Each compressor is hermetically sealed against contamination to help promote longer life and dependable operation. Each compressor also has vibration isolation to provide

quieter operation. All compressors have internal high pressure and overcurrent protection.

Direct-drive multi-speed brushless DC blower motor is standard on all PH3G--A models. Direct-drive, PSC (Permanent Split Capacitor) condenser-fan motors are designed to help reduce energy consumption and provide for cooling operation down to 40°F (4.4°C) outdoor temperature. Motormaster® II low ambient kit is available as a field installed accessory.

Thermostat controls designed to work as a system with Payne's small packaged product.

Thermostatic Expansion Valve - A hard shutoff, balance port TXV maintains a constant superheat at the evaporator exit (cooling cycle) resulting in higher overall system efficiency.

Refrigerant system is designed to provide dependability. Liquid filter driers are used to promote clean, unrestricted operation. Each unit leaves the factory with a full refrigerant charge. Refrigerant service connections make checking operating pressures easier.

High and Low Pressure Switches provide added reliability for the compressor.

Indoor and Outdoor coils are computer-designed for optimum heat transfer and efficiency. The indoor coil is fabricated from copper tube and aluminum fins and is located inside the unit for protection against damage. The outdoor coil is internally mounted on the top tier of the unit.

Low sound ratings ensure a quiet indoor and outdoor environment.

Easy to service cabinets provide easy 3-panel accessibility to serviceable components during maintenance and installation. The base with integrated drain pan provides easy ground level installation with a mounting pad. A nesting feature ensures a positive basepan to roof curb seal when the unit is roof mounted. A convenient 3/4-in. wide perimeter flange makes frame mounting on a rooftop easy.

Convertible duct configuration

Unit is designed for use in either downflow or horizontal applications. Each unit can be converted from horizontal to downflow and includes two horizontal duct covers. Downflow operation is provided in the field to allow vertical ductwork connections. The basepan seals on the bottom openings to ensure a positive seal in the vertical airflow mode.

Cabinets are constructed of heavy duty, phosphated, zinc-coated prepainted steel capable of withstanding 500 hours in salt spray. Interior surfaces of the evaporator and electric heater compartments are insulated with cleanable semi-rigid insulation board, which keeps the conditioned air from being affected by the outdoor ambient temperature and provides improved indoor air quality. (Conforms to American Society of Heating, Refrigeration and Air Conditioning Engineers No. 62P.) The sloped drain pan minimizes standing water in the drain. An external drain is provided.

Short-Cycling protection for the compressor is incorporated into our defrost control board ensuring a five minute delay (+/-2 minutes) before restarting compressor after shutdown for any reason.

TABLE OF CONTENTS

- FEATURES/BENEFITS 1-2
- MODEL NUMBER NOMENCLATURE 2
- ARI CAPACITIES 3
- PHYSICAL DATA 4
- OPTIONS AND ACCESSORIES 5
- BASE UNIT DIMENSIONS 7-8
- ACCESSORY DIMENSIONS 9
- SELECTION PROCEDURE 10
- PERFORMANCE DATA 11-19
- TYPICAL PIPING AND WIRING 20
- APPLICATION DATA 21
- ELECTRICAL DATA 22-23
- TYPICAL WIRING SCHEMATICS 24-26
- CONTROLS 27
- GUIDE SPECIFICATIONS 28-29

PH3G --A

MODEL NUMBER NOMENCLATURE

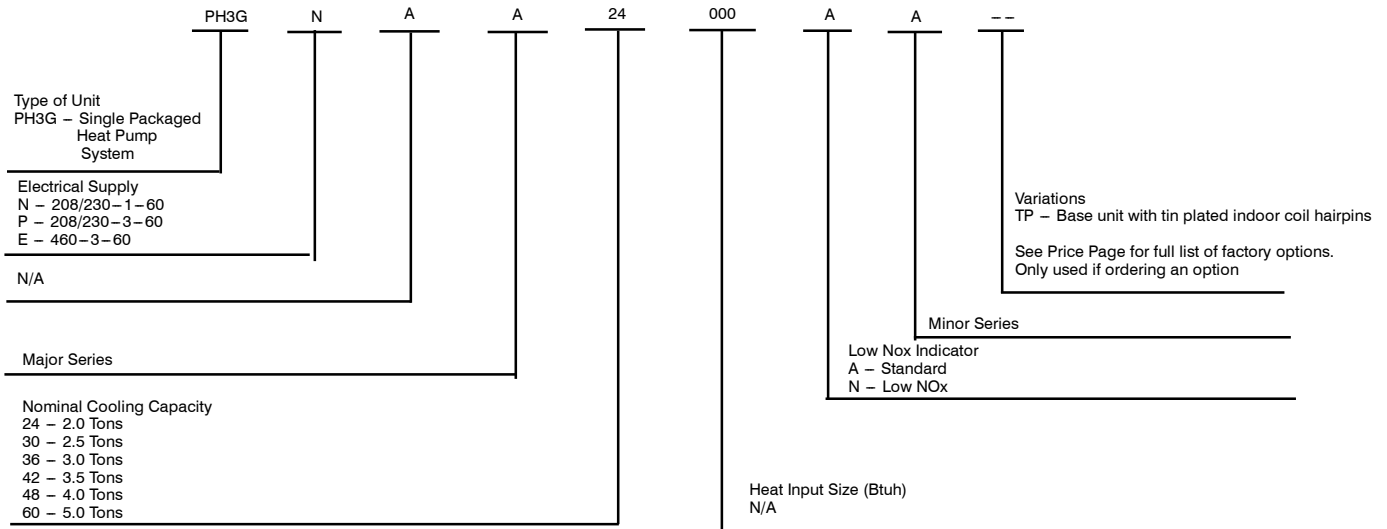

ARI* CAPACITIES

COOLING CAPACITIES AND EFFICIENCIES

UNIT PH3G--A	NOMINAL TONS	STANDARD CFM	COOLING CAPACITIES (Btuh)	EER**	SEER†
24	2	800	23,800	11.5	13.5
30	2-1/2	1000	29,000	11.5	13.5
36	3	1200	35,000	11.5	13.5
42	3-1/2	1400	40,000	11.5	13.2
48	4	1600	47,000	11.5	13.5
60	5	1850	57,000	11.5	13.5

HEAT PUMP HEATING CAPACITIES AND EFFICIENCIES

UNIT PH3G--A	HEATING CAPACITY (Btuh) @ 47°F (8.3°C)	COP @ 47°F (8.3°C)	HEATING CAPACITY (Btuh) @ 17°F (-8.3°C)	COP @ 17°F (-8.3°C)	HSPF†
24	23,400	3.5	10,800	2.2	7.7
30	29,000	3.5	15,900	2.2	7.7
36	35,000	3.4	20,400	2.3	7.7
42	40,000	3.4	22,000	2.2	7.7
48	46,500	3.6	26,200	2.3	7.7
60	57,000	3.5	31,000	2.3	7.7

PH3G--A

LEGEND

dB—Sound Levels (decibels)

db—Dry Bulb

SEER—Seasonal Energy Efficiency Ratio

wb—Wet Bulb

COP—Coefficient of Performance

HSPF—Heating Season Performance Factor

* Air Conditioning & Refrigeration Institute.

**At "A" conditions—80°F (26.7°C) indoor db/67°F (19.4°C) indoor wb & 95°F (35°C) outdoor db.

† Rated in accordance with U.S. Government DOE Department of Energy) test procedures and/or ARI Standards 210/240.

Notes:

1. Ratings are net values, reflecting the effects of circulating fan heat.

Ratings are based on:

Cooling Standard: 80°F (26.7°C) db, 67°F (19.4°C) wb indoor entering—air temperature and 95°F (35°C) db outdoor entering—air temperature.

2. Before purchasing this appliance, read important energy cost and efficiency information available from your retailer.

PHYSICAL DATA - UNIT PH3G--A

UNIT SIZE	PH3G--A24	PH3G--A30	PH3G--A36	PH3G--A42	PH3G--A48	PH3G--A60
NOMINAL CAPACITY (ton)	2	2.5	3	3.5	4	5
SHIPPING WEIGHT† (lb)	327	340	343	419	437	462
(kg)	148	154	156	190	198	210
COMPRESSOR QUANTITY	1					
TYPE	SCROLL COMPRESSOR					
REFRIGERANT	R-410A					
Refrigerant (R-410A) Quantity (lb)	9.6	10.2	7.9	10.0	9.6	12.3
Quantity (kg)	4.4	4.6	3.6	4.5	4.4	5.6
METERING DEVICE ID	TXV					
ORIFICE OD (in.) (mm)	0.032 (2) .81	0.035 (2) .89	0.037 (2) .94	0.038 (Left OD Coil) 0.040 (Right OD Coil) .97/1.02	0.046 (2) 1.2	0.052 (2) 1.3
OUTDOOR COIL Rows... Fins/in. face area (sq. ft.)	2...21 11.9	2...21 11.9	2...21 11.9	2...21 13.6	2...21 13.6	2...21 17.5
OUTDOOR FAN Nominal Airflow (CFM) Fan Diameter (in.) Fan Diameter (mm) Diameter Motor HP (RPM)	2700 24 610 1/5 (810)	2700 24 610 1/5 (810)	2700 24 610 1/5 (810)	3100 26 660 1/5 (810)	3100 26 660 1/5 (810)	3100 26 660 1/5 (810)
INDOOR COIL Rows... Fins/in. face area (sq. ft.)	3...17 3.7	3...17 3.7	3...17 3.7	3...17 4.7	3...17 4.7	3...17 5.7
INDOOR BLOWER Nominal Cooling Airflow (CFM) Size (in.) (mm) Motor (HP)	800 10x10 254x254 1/2	1000 10x10 254x254 1/2	1200 11x10 279x254 3/4	1400 11x10 279x254 3/4	1600 11x10 279x254 1.0	1850 11x10 279x254 1.0
HIGH-PRESSURE SWITCH (psig) Cutout Reset (Auto)	650±15 420±25					
LOSS-OF-CHARGE/LOW-PRESSURE SWITCH (Liquid Line) (psig) Cutout Reset (Auto)	20±5 45±10 20±5 45±10					
RETURN-AIR FILTERS*† throwaway (in.) (mm)	20x20x1 508x508x25	20x24x1 508x610x25	24x30x1 610x762x25		24x36x1 610x914x25	

*Required filter sizes shown are based on the larger of the ARI (Air conditioning and Refrigeration Institute) rated cooling airflow or the heating airflow velocity of 300 ft/minute for throwaway type or 450 ft/minute for high-capacity type. Air filter pressure drop for non-standard filters must not exceed 0.08 IN. W.C.

† If using accessory filter rack refer to the filter rack installation instructions for correct filter size and quantity.

‡ For 460 volt units, add 14 lb (6.4 kg) to the weight.

A-Weighted Sound Power Level (dBA)

MODEL PH3G--A	STANDARD RATING (dBA)	TYPICAL OCTAVE BAND SPECTRUM (dBA) (without tone adjustment)						
		125	250	500	1000	2000	4000	8000
24	76	57.0	65.5	72.0	71.0	67.0	62.0	53.0
30	76	60.5	67.5	72.0	70.0	67.0	61.0	51.5
36	77	63.0	68.0	73.0	71.0	67.0	62.0	55.0
42	78	65.0	68.5	74.5	72.5	69.5	64.5	56.5
48	78	62.0	68.5	74.0	72.5	70.0	64.0	56.0
60	76	63.0	66.5	69.5	71.0	66.0	65.0	59.0

NOTE: Tested in accordance with ARI Standard 270 (not listed in ARI).

OPTIONS AND ACCESSORIES

ITEM	DESCRIPTION	FACTORY INSTALLED OPTION	FIELD INSTALLED ACCESSORY
Coil Options	Base unit with tin plated indoor coil hairpins	X	
Compressor Start Kit	Compressor Start Kit assists compressor start-up by providing additional starting torque on sing phase units only.		X
Corporate Thermostats	Thermostats provide control for the system heating and cooling functions.		X
Crankcase Heater	Crankcase Heater provides anti-floodback protection for low-load cooling applications.		X*
Economizer	Horizontal Economizer with solid state controls and barometric relief dampers includes filter racks and provide outdoor air during cooling and reduce compressor operation.		X
	Vertical Economizer with solid state controls and barometric relief dampers includes filter racks and provide outdoor air during cooling and reduce compressor operation.		X
Electric Heaters	Electric Heat Supplement		X
Filter Rack	Filter Rack features easy installation, serviceability, and high-filtering performance for vertical applications. Includes 1-in. (25 mm) filter.		X
Flat Roof Curbs	Flat Roof Curbs in both 11-in (279 mm) and 14-in. (356 mm) sizes are available for roof mounted applications.		X
Low Ambient Kit	Low Ambient Kit (Motormaster II Control) allows the use of mechanical cooling down to outdoor temperatures as low as 0°F (-18°C) when properly installed.		X
Louver Metal Outdoor Coil Grilles	Louver Metal Outdoor Coil Grilles provides hail and vandalism protection.		X
Manual Outside Air Damper	Manual Outside Air Damper includes hood and filter rack with adjustable damper blade for up to 25% outdoor air.		X
Square-to-Round Duct Transition Kit	Square-to-Round Duct Transition Kit enable 24-48 size units to be fitted to 14 in. (356 mm) round ductwork.		X
Curb Adapter	Adapter curb for new unit with base rail installed on existing curb		X
Gasket Kit	For field modified existing roof curb with new base rail unit.		X

*Refer to Price Page for application detail.

PH3G--A

ELECTRIC HEATERS

ORDERING NO.	NOMINAL CAPACITY (kW @ 240 or 480 VOLTS)	USED WITH SIZES					
		24	30	36	42	48	60
208/230 – SINGLE PHASE – 60 HZ							
CPHEATER052A00	5.0	X	X	X			
CPHEATER064A00	5.0	X	X	X	X	X	X
CPHEATER070A00	7.2	X	X	X	X	X	X
CPHEATER050A00	10.0	X	X	X	X	X	X
CPHEATER066A00	15.0		X	X	X	X	X
CPHEATER054A00	20.0				X	X	X
208/230 – THREE PHASE – 60 HZ							
CPHEATER055A00	5.0		X	X	X	X	X
CPHEATER056A00	10.0		X	X	X	X	X
CPHEATER068A00	10.0		X	X	X	X	X
CPHEATER058A00	15.0		X	X	X	X	X
CPHEATER059A01	20.0				X	X	X
460 – THREE PHASE – 60 HZ							
CPHEATER060A00	5.0			X	X	X	X
CPHEATER061A00	10.0			X	X	X	X
CPHEATER062A00	15.0			X	X	X	X
CPHEATER063A00	20.0				X	X	X

NOTE: Electric heaters are rated at 240v. Refer to Multiplication Factors table for other voltages.

X = Approved combination

Minimum Airflow for Reliable Electric Heater Operation (CFM)

SIZE	PH3G--A24	PH3G--A30	PH3G--A36	PH3G--A42	PH3G--A48	PH3G--A60
AIRFLOW (CFM)	800	1025	1250	1400	1710	1800

ECONOMIZER

PH3G--A

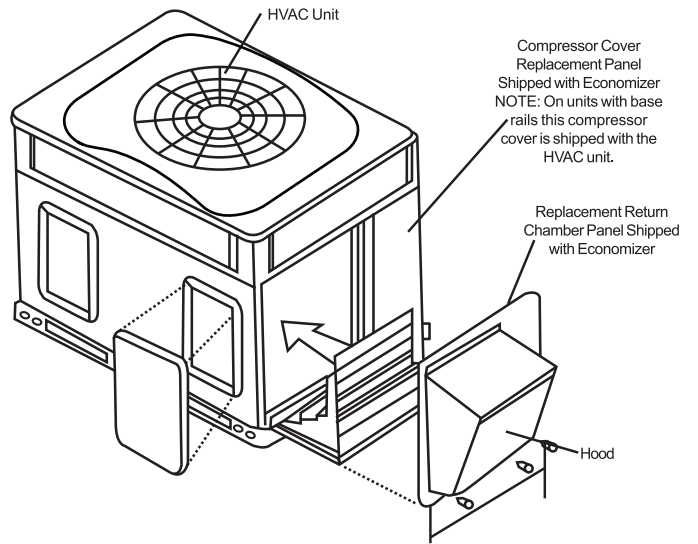
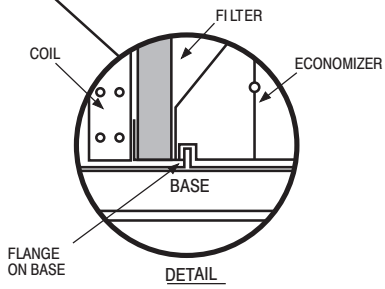
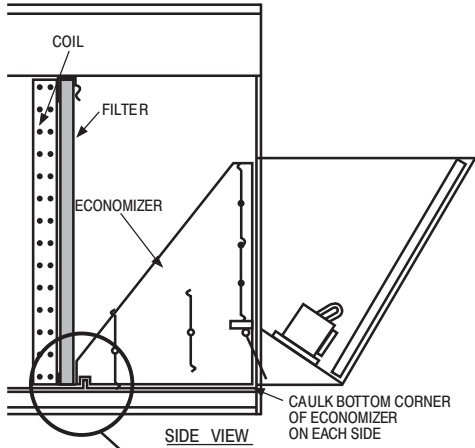

Vertical Economizer

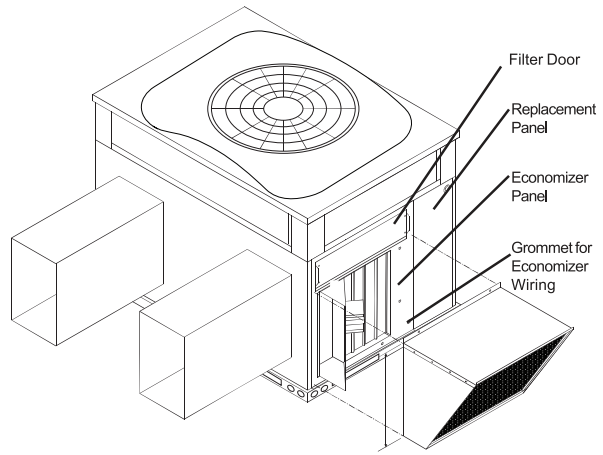

Horizontal Economizer

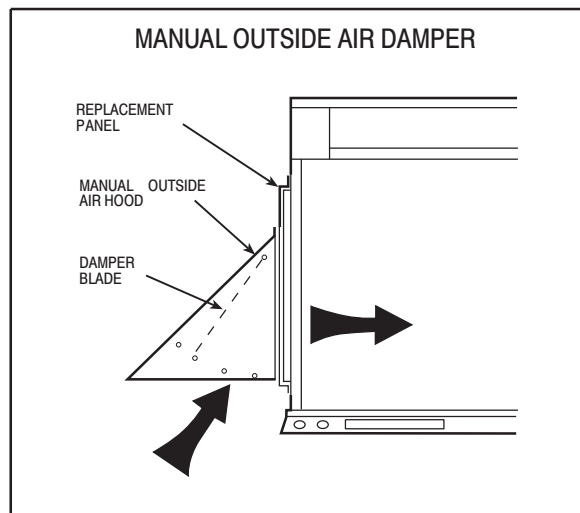
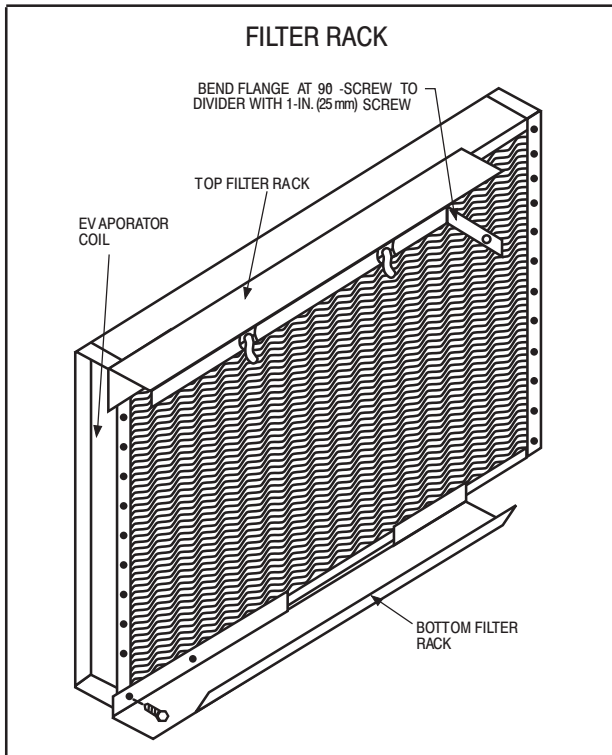

A09421

UNIT DIMENSIONS - PH3G--A24-36

UNIT	ELECTRICAL CHARACTERISTICS	UNIT WT. LB. KG.	UNIT HEIGHT IN/MM			CENTER OF GRAVITY IN/MM		
			"A"	X	Y	Z		
PH3GNA24000AA	208/230-1-60	320 145.0	42-1/8 (1070)	19-3/4 (501.7)	14-3/4 (374.7)	17-1/2 (444.5)		
PH3G(N.P.)AA30000AA	208/230-1, 208/230-3-60	332 150.7	42-1/8 (1070)	19-3/4 (501.7)	14-3/4 (374.7)	17-7/8 (454.0)		
PH3G(N.P.)AA36000AA	208/230-1, 208/230-3-60	336 152.3	42-1/8 (1070)	19-3/4 (501.7)	14-3/4 (374.7)	18 (457.2)		
PH3GEAA36000AA	460-3-60	350 158.6	42-1/8 (1070)	19-3/4 (501.7)	14-3/4 (374.7)	18-1/2 (469.3)		

UNITS	VOLTAGE	CORNER WEIGHT LB/KG	
		"1"	"4"
PH3GNA24000AA	208/230	64.0 (29.0)	51.2 (23.2)
PH3G(N.P.)AA30000AA	208/230	66.5 (30.2)	53.2 (24.1)
PH3G(N.P.)AA36000AA	208/230	67.2 (30.5)	53.7 (24.4)
PH3GEAA36000AA	460	67.2 (30.5)	53.7 (24.4)

NOTE: ALL TABLE DATA RELEVANT FOR ALL FACTORY INSTALLED OPTIONS EXCEPT ECONOMIZER

- REQUIRED CLEARANCES TO COMBUSTIBLE MATL.
- INCHES (MM)
- TOP OF UNIT.....1 (25.4)
 - DUCT SIDE OF UNIT.....2 (50.8)
 - SIDE OPPOSITE DUCTS.....14 (355.6)
 - BOTTOM OF UNIT.....0 (0.0)
 - ELECTRICAL PANEL.....36 (914.4)
- NEC. REQUIRED CLEARANCES.
- INCHES (MM)
- BETWEEN UNITS, POWER ENTRY SIDE.....42 (1066.8)
 - UNIT AND UNGROUNDED SURFACES, POWER ENTRY SIDE.....36 (914.0)
 - UNIT AND BLOCK OR CONCRETE WALLS AND OTHER GROUNDED SURFACES, POWER ENTRY SIDE.....42 (1066.8)
- REQUIRED CLEARANCE FOR OPERATION AND SERVICING
- INCHES (MM)
- EVAP. COIL, ACCESS SIDE.....36 (914.0)
 - CONDENSER COIL, ACCESS SIDE.....42 (1066.8)
 - (EXCEPT FOR NEC REQUIREMENTS)
 - UNIT TOP.....48 (1219.2)
 - SIDE OPPOSITE DUCTS.....36 (914.0)
 - DUCT PANEL.....12 (304.8)
- MINIMUM DISTANCES: IF UNIT IS PLACED LESS THAN 12 (304.8) FROM WALL SYSTEM, THEN SYSTEM PERFORMANCE MAYBE COMPROMISED.

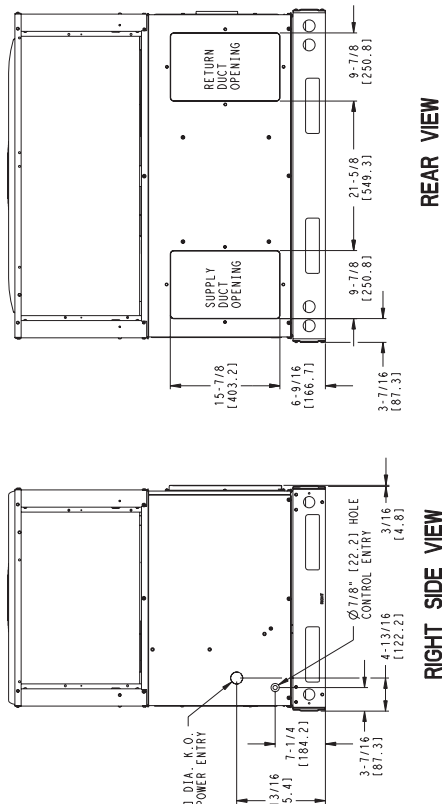
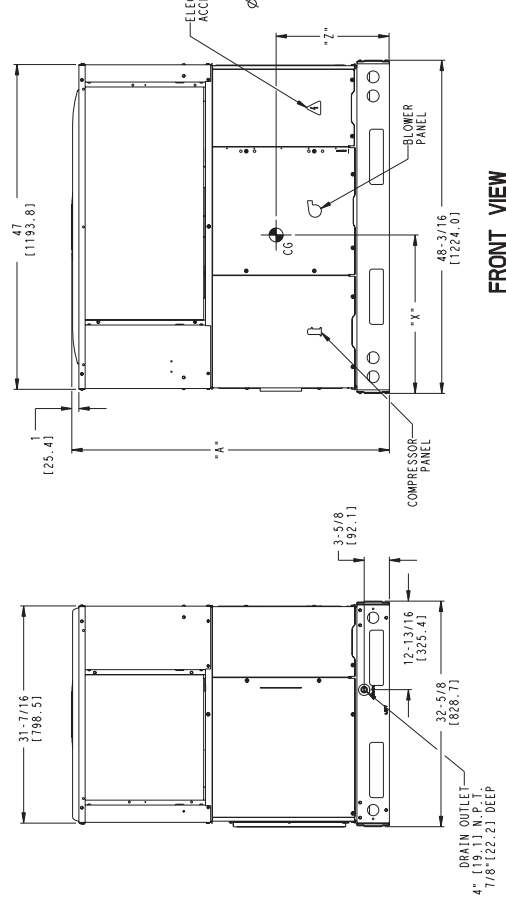
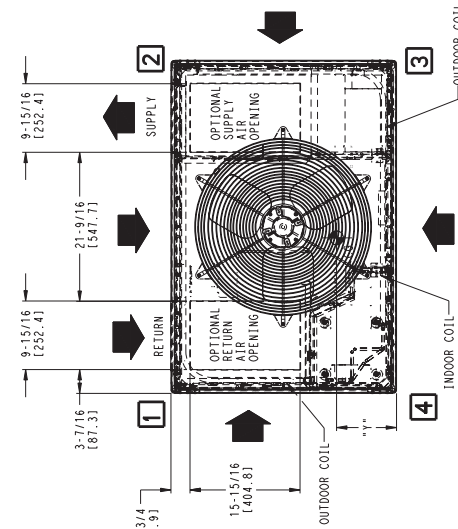

50E2500508
REV 3.0

PH3G--A

UNIT DIMENSIONS - PH3G--A42-60

PH3G--A

UNIT	ELECTRICAL CHARACTERISTICS	UNIT WT.		UNIT HEIGHT IN/MM		CENTER OF GRAVITY IN/MM					
		LB	KG	"A"	"A"	X	Y	Z	Z		
PH3G(N.P1A42000AA)	208/230-1, 208/230-3-60	411	186.3	44-3/4	1137	19-1/2	495.3	16-1/2	419.1	17	431.8
PH3G(AA42000AA)	460-3-60	425	192.7	44-3/4	1137	19-1/2	495.3	16-1/2	419.1	17	431.8
PH3G(N.P1A448000AA)	208/230-1, 208/230-3-60	429	194.7	44-3/4	1137	19-1/2	495.3	16-1/2	419.1	17	431.8
PH3G(AA48000AA)	460-3-60	443	201.1	44-3/4	1137	19-1/2	495.3	16-1/2	419.1	17	431.8
PH3G(N.P1A46000AA)	208/230-1, 208/230-3-60	454	206.0	48-3/4	1238	19-1/2	495.3	16-1/2	419.1	18	457.2
PH3G(AA60000AA)	460-3-60	468	212.4	48-3/4	1238	19-1/2	495.3	16-1/2	419.1	18	457.2

UNITS	CORNER WEIGHT LB/KG								
	"1"	"2"	"3"	"4"					
PH3G(N.P1A42000AA)	209/230	82.1	37.3	65.7	29.8	98.6	44.8	164.3	74.6
PH3G(AA2000AA)	460	82.1	37.3	65.7	29.8	107.6	48.8	169.3	76.9
PH3G(N.P1A448000AA)	209/230	85.8	39.0	68.7	31.2	103.0	46.8	171.7	71.9
PH3G(AA48000AA)	460	85.8	39.0	68.7	31.2	112.0	50.8	176.7	80.2
PH3G(N.P1A46000AA)	209/230	90.8	41.2	72.7	33.0	109.0	49.3	181.7	82.5
PH3G(AA6000AA)	460	90.8	41.2	72.7	33.0	118.0	53.6	186.7	84.8

NOTE: ALL TABLE DATA RELEVANT FOR ALL FACTORY INSTALLED OPTIONS EXCEPT ECONOMIZER

REQUIRED CLEARANCES TO COMBUSTIBLE MATL.

	INCHES (MM)
TOP OF UNIT	2 (50.8)
DUCT SIDE OF UNIT	14 (355.6)
SIDE OPPOSITE DUCT	14 (355.6)
BOTTOM OF UNIT	0 (0.0)
ELECTRICAL PANEL	36 (914.4)

NEC - REQUIRED CLEARANCES.

	INCHES (MM)
BETWEEN UNITS, POWER ENTRY SIDE	42 (1066.8)
UNIT AND UNGROUND SURFACES, POWER ENTRY SIDE	36 (914.4)
BETWEEN UNITS, CONDENSATE DRAIN AND OTHER GROUND SURFACES, POWER ENTRY SIDE	42 (1066.8)

	INCHES (MM)
EVAP. COIL ACCESS SIDE	42 (1066.8)
POWER ENTRY SIDE	42 (1066.8)
(EXCEPT FOR NEC REQUIREMENTS)	48 (1219.2)
UNIT TOP	36 (914.4)
SIDE OPPOSITE DUCTS	12 (304.8)
DUCT PANEL	12 (304.8)

*MINIMUM DISTANCES: IF UNIT IS PLACED LESS THAN 12 (304.8) FROM WALL SYSTEM, THEN SYSTEM PERFORMANCE MAYBE COMPROMISED.

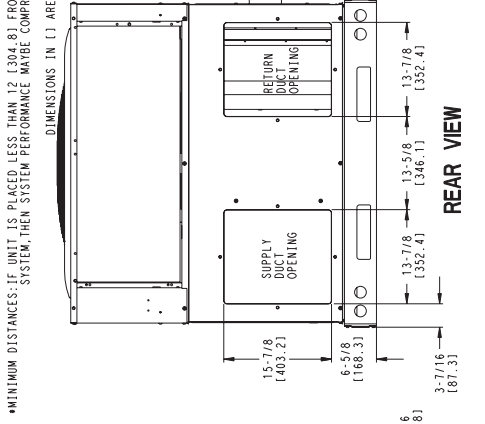
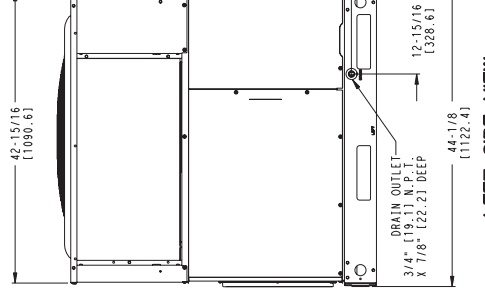
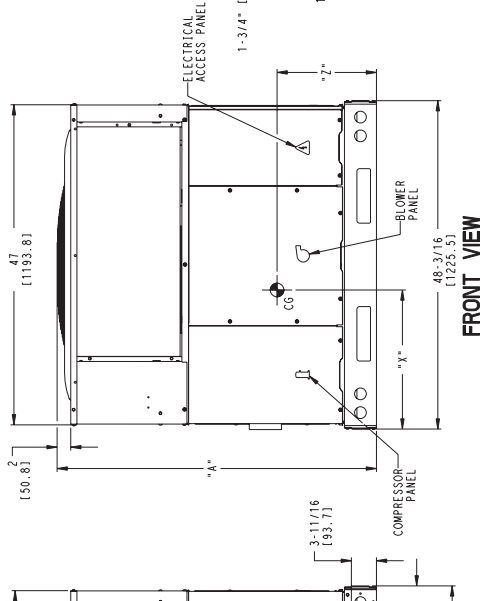
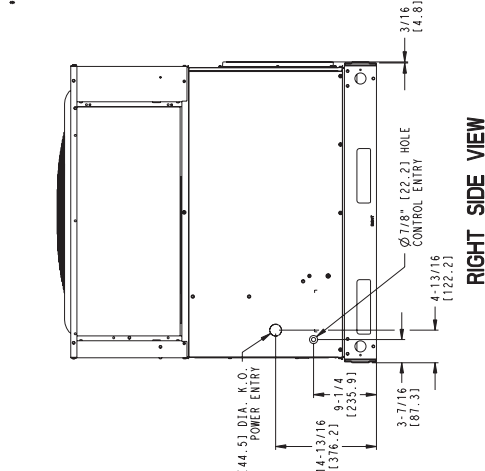
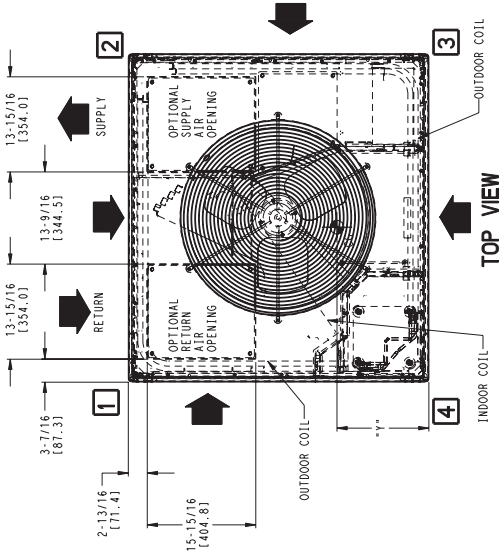

50EZ500509
REV 3.0

ACCESSORY DIMENSIONS

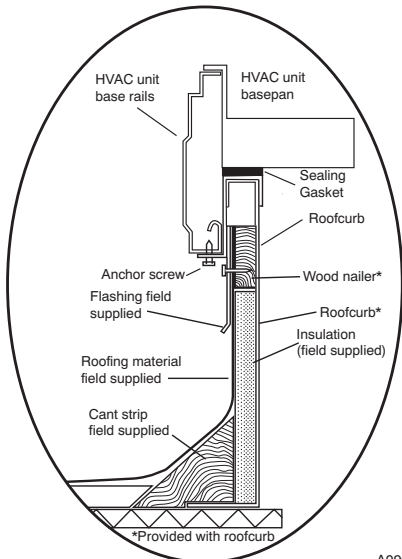

A09090

ROOF CURB DETAIL

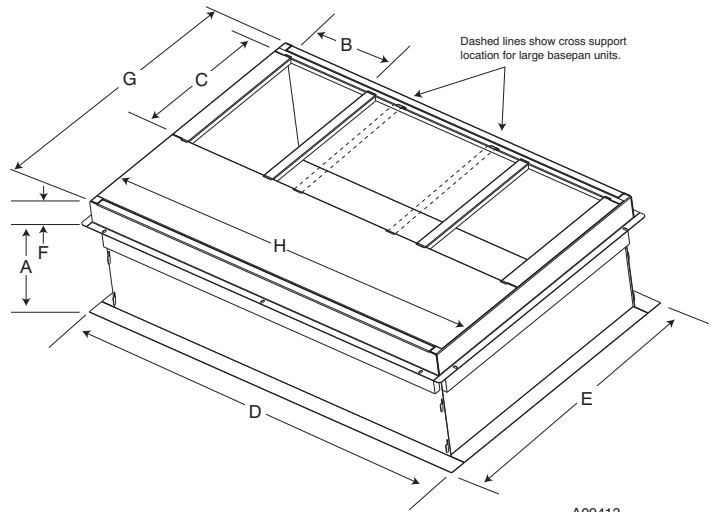

SMALL/COMMON CURB

A09413

PH3G--A

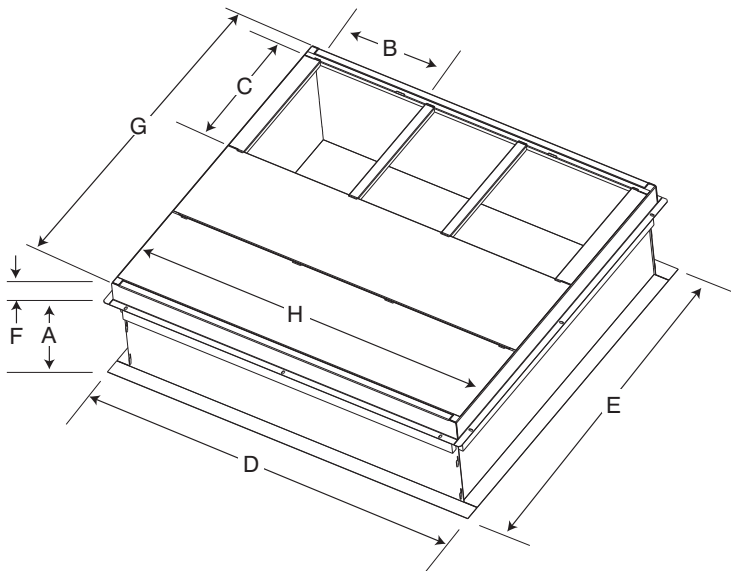

LARGE CURB

A09415

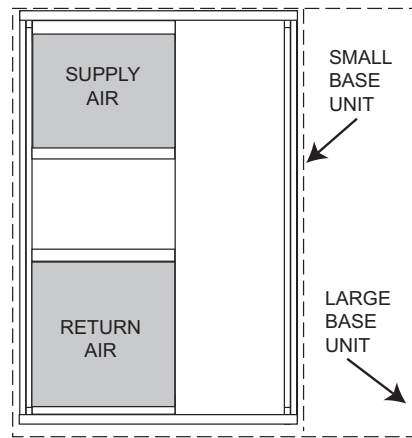

UNIT PLACEMENT ON COMMON CURB

A09094

SMALL OR LARGE BASE UNIT

A09414

UNIT SIZE	CATALOG NUMBER	A IN. (mm)	B (small/common base) IN. (mm)*	B (large base) IN. (mm)*	C IN. (mm)	D IN. (mm)	E IN. (mm)	F IN. (mm)	G IN. (mm)	H IN. (mm)
Small or Large	CPRFCURB010A00	11 (279)	10 (254)	14 (356)	16 (406)	47.8 (1214)	32.4 (822)	2.7 (69)	30.6 (778)	46.1 (1170)
	CPRFCURB011A00	14 (356)								
Large	CPRFCURB012A00	11 (279)	14 (356)	14 (356)	16 (406)	47.8 (1214)	43.9 (1116)	2.7 (69)	42.2 (1072)	46.1 (1170)
	CPRFCURB013A00	14 (356)								

* Part Numbers CPRFCURB010A00 and CPRFCURB011A00 can be used on both small and large basepan units. The cross supports must be located based on whether the unit is a small basepan or a large basepan.

NOTES:

1. Roof curb must be set up for unit being installed.
2. Seal strip must be applied, as required, to unit being installed.
3. Roof curb is made of 16-gauge steel.
4. Attach ductwork to curb (flanges of duct rest on curb).
5. Insulated panels: 1-in. (25.4 mm) thick fiberglass 1 lb. density.

SELECTION PROCEDURE (WITH EXAMPLE)

1. Determine cooling and heating requirements at design conditions:

Given:

Required Cooling Capacity (TC) 34,500 Btuh
 Sensible Heat Capacity (SHC) 26,000 Btuh
 Required Heating Capacity 60,000 Btuh
 Condenser Entering Air Temperature 95°F (35°C)
 Indoor-Air Temperature 80°F (27°C) edb 67°F (19°C) ewb
 Evaporator Air Quantity 1200 CFM
 External Static Pressure 0.200 IN.W.C.
 Electrical Characteristics 208-1-60

2. Select unit based on required cooling capacity.

Enter Net Cooling Capacities table at condenser entering temperature of 95°F (35°C). Unit 036 at 1200 cfm and 67°F (19°C) ewb (entering wet bulb) will provide a total capacity of 35,000 Btuh and a SHC of 26,200 Btuh. Calculate SHC correction, if required, using Note 4 under Cooling Capacities tables.

3. Select heating capacity of unit to provide design condition requirement.

In the Heating Capacities and Efficiencies table, note that the 36 size unit will deliver 35,000 BTUH at the ARI high temp rating point. To achieve 60,000 BTUH, accessory electric heat will be required. Use the Balance Point Worksheet to plot the load line with the unit capacity. The difference between the load line and unit capacity at the design heating temperature is the amount of electric heat that will be required.

4. Determine fan speed and power requirements at design conditions.

Before entering the air delivery tables, calculate the total static pressure required. From the given example, the Wet Coil Pressure Drop Table, and the Filter Pressure Drop Table:

External Static Pressure	0.200 IN. W.C.
Filter	0.130 IN. W.C.
Wet Coil Pressure Drop	<u>0.18</u> IN. W.C.
Total Static Pressure	0.51 IN. W.C.

Enter the table for Dry Coil Air Delivery— At 0.50 IN. W.C. ESP (external static pressure) and MEDIUM speed the motor delivers 1209 cfm.

5. Select unit that corresponds to power source available.

The Electrical Data Table shows that the unit is designed to operate at 208/230-1-60.

PERFORMANCE DATA

24 Cooling Extended Performance Table

EVAPORATOR AIR		CONDENSER ENTERING AIR TEMPERATURES °F (°C)																	
CFM / BF	EWB °F (°C)	75 (23.9)			85 (29.4)			95 (35)			105 (40.5)			115 (46.1)			125 (51.7)		
		Capacity MBtuh	Total Sys KW	Capacity MBtuh	Total Sys KW	Capacity MBtuh	Total Sys KW	Capacity MBtuh	Total Sys KW	Capacity MBtuh	Total Sys KW	Capacity MBtuh	Total Sys KW	Capacity MBtuh	Total Sys KW	Capacity MBtuh	Total Sys KW		
		Total	Sens	Total	Sens	Total	Sens	Total	Sens	Total	Sens	Total	Sens	Total	Sens	Total	Sens		
700 / 0.11	57 (13.9)	22.38	22.38	21.54	21.54	20.63	20.63	2.01	19.64	19.64	18.54	18.54	2.27	18.54	18.54	2.56	17.33	17.33	2.88
	62 (16.7)	23.32	21.00	22.26	20.45	19.85	19.85	2.02	19.92	19.18	18.63	18.50	2.27	18.63	18.50	2.56	17.36	17.36	2.88
	63* (17.2)	23.73	17.21	22.64	16.69	16.14	21.47	2.02	20.21	15.55	18.82	14.89	2.27	18.82	14.89	2.56	14.19	14.19	2.88
	67 (19.4)	25.65	17.94	24.48	17.42	16.87	23.23	2.04	21.88	16.28	20.41	15.64	2.30	20.41	15.64	2.58	18.80	14.93	2.89
	72 (13.9)	28.26	14.67	26.98	14.19	13.68	25.61	2.08	24.14	13.14	22.52	12.55	2.34	22.52	12.55	2.62	20.77	11.88	2.93
	57 (13.9)	23.50	23.50	22.59	22.59	21.61	21.77	2.04	20.54	20.54	19.37	19.37	2.30	19.37	19.37	2.58	18.07	18.07	2.90
	62 (16.7)	24.02	22.63	22.92	22.02	18.1	21.32	2.04	20.58	20.58	19.40	19.40	2.30	19.40	19.40	2.58	18.10	18.10	2.90
800 / 0.15	63* (17.2)	24.39	18.39	23.24	17.85	17.28	22.02	2.04	20.69	16.67	19.25	15.98	2.30	19.25	15.98	2.58	17.68	15.23	2.90
	67 (19.4)	26.34	19.21	25.11	18.67	18.10	23.80	2.07	22.38	17.48	20.84	16.81	2.32	20.84	16.81	2.60	19.17	16.06	2.92
	72 (13.9)	29.00	15.54	27.64	15.04	14.53	26.19	2.12	24.66	13.93	22.98	13.29	2.37	22.98	13.29	2.65	21.15	12.59	2.95
	57 (13.9)	24.45	24.45	23.48	23.48	22.45	22.45	2.07	21.31	21.31	20.06	20.06	2.32	20.06	20.06	2.61	18.69	18.69	2.93
	62 (16.7)	24.64	24.10	23.54	23.54	22.49	22.49	2.07	21.34	21.34	20.10	20.10	2.32	20.10	20.10	2.61	18.71	18.71	2.93
	63* (17.2)	24.92	19.53	23.72	18.97	18.37	22.45	2.07	21.07	17.72	19.58	17.01	2.32	19.58	17.01	2.60	17.97	16.22	2.92
	67 (19.4)	26.89	20.43	25.60	19.87	18.63	24.25	2.10	22.78	18.63	21.18	17.93	2.35	21.18	17.93	2.63	19.46	17.14	2.94
72 (13.9)	29.56	16.36	28.16	15.83	15.26	26.67	2.15	25.07	14.65	23.33	13.99	2.40	23.33	13.99	2.67	21.45	13.27	2.98	

*At 75°F (23.9 °C) entering dry bulb—Tennessee Valley Authority [TVA] rating conditions; all others at 80°F (26.7 °C) entering dry bulb. See Legend and Notes.

24 Heating Extended Performance Table -10-60 (-23.3-15.6 °C)

INDOOR AIR		OUTDOOR COIL ENTERING AIR TEMPERATURES °F (°C)																							
EDB °F (°C)	CFM	-10 (-23.3)			0 (-17.8)			10 (-12.2)			20 (-6.7)			30 (-1.1)			40 (4.4)			50 (10)			60 (15.6)		
		Capacity MBtuh	Total Sys KW	Capacity MBtuh	Total Sys KW	Capacity MBtuh	Total Sys KW	Capacity MBtuh	Total Sys KW	Capacity MBtuh	Total Sys KW	Capacity MBtuh	Total Sys KW	Capacity MBtuh	Total Sys KW	Capacity MBtuh	Total Sys KW	Capacity MBtuh	Total Sys KW	Capacity MBtuh	Total Sys KW	Capacity MBtuh	Total Sys KW		
		Total	Sens	Total	Sens	Total	Sens	Total	Sens	Total	Sens	Total	Sens	Total	Sens	Total	Sens	Total	Sens	Total	Sens	Total	Sens		
65	700	7.81	7.18	1.51	10.21	9.39	1.62	13.03	11.96	1.71	15.49	14.05	1.76	18.20	15.95	1.81	21.29	21.29	1.87	24.98	24.98	1.97	29.37	29.37	2.13
	800	7.93	7.29	1.51	10.35	9.52	1.62	13.17	12.09	1.70	15.63	14.18	1.74	18.38	16.11	1.78	21.53	21.53	1.83	25.30	25.30	1.92	29.63	29.63	2.05
	900	8.02	7.38	1.52	10.45	9.62	1.62	13.28	12.19	1.89	15.76	14.29	1.73	18.54	16.24	1.76	21.73	21.73	1.80	25.52	25.52	1.89	29.60	29.60	2.02
70	700	7.49	6.89	1.59	9.88	9.10	1.70	12.47	11.44	1.79	15.29	13.87	1.86	17.96	15.74	1.91	20.99	20.99	1.97	24.59	24.59	2.07	28.92	28.92	2.23
	800	7.61	7.00	1.59	10.04	9.24	1.70	12.72	11.68	1.78	15.43	14.00	1.83	18.14	15.89	1.87	21.22	21.22	1.93	24.90	24.90	2.02	29.27	29.27	2.16
	900	7.71	7.09	1.59	10.16	9.35	1.70	12.88	11.82	1.77	15.55	14.10	1.85	18.28	16.02	1.85	21.42	21.42	1.90	25.15	25.15	1.99	29.31	29.31	2.12
75	700	7.14	6.57	1.67	9.56	8.80	1.79	12.14	11.14	1.88	15.07	13.67	1.96	17.72	15.52	2.01	20.69	20.69	2.08	24.22	24.22	2.18	28.47	28.47	2.34
	800	7.25	6.67	1.67	9.71	8.93	1.78	12.31	11.30	1.86	15.22	13.81	1.93	17.89	15.68	1.98	20.92	20.92	2.03	24.53	24.53	2.12	28.86	28.86	2.28
	900	7.37	6.78	1.67	9.83	9.04	1.78	12.46	11.43	1.86	15.35	13.92	1.92	18.04	15.81	1.95	21.11	21.11	2.00	24.76	24.76	2.09	28.98	28.98	2.22

PERFORMANCE DATA (CONT)
30 Cooling Extended Performance Table

EVAPORATOR AIR		CONDENSER ENTERING AIR TEMPERATURES °F (°C)																									
		75 (23.9)			85 (29.4)			95 (35)			105 (40.5)			115 (46.1)			125 (51.7)										
		CFM / BF	EWB °F (°C)	Capacity MBtuh	Total Sys KW	Capacity MBtuh	Total Sys KW	Capacity MBtuh	Total Sys KW	Capacity MBtuh	Total Sys KW	Capacity MBtuh	Total Sys KW	Capacity MBtuh	Total Sys KW	Capacity MBtuh	Total Sys KW	Capacity MBtuh	Total Sys KW								
		27.44	27.44	2.00	26.40	2.22	25.31	2.47	24.13	2.75	22.83	3.07	21.42	3.44	27.44	27.44	2.00	26.40	2.22	25.31	2.47	24.13	2.75	22.83	3.07	21.42	3.44
		28.39	25.49	2.00	24.83	2.22	25.75	2.47	24.34	2.75	22.88	3.07	21.45	3.44	28.39	25.49	2.00	24.83	2.22	25.75	2.47	24.34	2.75	22.88	3.07	21.45	3.44
		28.86	20.79	2.00	20.17	2.22	26.13	2.47	24.63	2.75	23.00	3.07	21.25	3.44	28.86	20.79	2.00	20.17	2.22	26.13	2.47	24.63	2.75	23.00	3.07	21.25	3.44
		31.27	21.73	2.02	21.10	2.24	28.33	2.49	26.73	2.76	25.00	3.08	23.14	3.45	31.27	21.73	2.02	21.10	2.24	28.33	2.49	26.73	2.76	25.00	3.08	23.14	3.45
		34.57	17.68	2.04	17.10	2.26	31.32	2.51	29.56	2.79	27.68	3.10	25.66	3.46	34.57	17.68	2.04	17.10	2.26	31.32	2.51	29.56	2.79	27.68	3.10	25.66	3.46
		28.78	28.78	2.04	27.67	2.26	26.49	2.50	25.23	2.78	23.84	3.11	22.33	3.47	28.78	28.78	2.04	27.67	2.26	26.49	2.50	25.23	2.78	23.84	3.11	22.33	3.47
		29.25	27.45	2.04	26.71	2.26	26.55	2.50	25.27	2.79	23.88	3.11	22.37	3.47	29.25	27.45	2.04	26.71	2.26	26.55	2.50	25.27	2.79	23.88	3.11	22.37	3.47
		29.64	22.24	2.04	21.59	2.26	26.76	2.51	25.20	2.78	23.51	3.10	21.89	3.47	29.64	22.24	2.04	21.59	2.26	26.76	2.51	25.20	2.78	23.51	3.10	21.89	3.47
		32.09	23.29	2.05	22.64	2.28	29.00	2.52	27.32	2.80	25.54	3.12	23.60	3.48	32.09	23.29	2.05	22.64	2.28	29.00	2.52	27.32	2.80	25.54	3.12	23.60	3.48
		35.47	18.74	2.08	18.14	2.30	32.02	2.55	30.20	2.82	26.25	3.14	26.14	3.49	35.47	18.74	2.08	18.14	2.30	32.02	2.55	30.20	2.82	26.25	3.14	26.14	3.49
		29.95	29.95	2.07	28.75	2.29	27.50	2.54	26.15	2.82	24.69	3.14	23.10	3.51	29.95	29.95	2.07	28.75	2.29	27.50	2.54	26.15	2.82	24.69	3.14	23.10	3.51
		30.03	30.03	2.07	28.81	2.30	27.55	2.54	26.20	2.82	24.73	3.14	23.14	3.51	30.03	30.03	2.07	28.81	2.30	27.55	2.54	26.20	2.82	24.73	3.14	23.14	3.51
		30.27	23.63	2.07	22.96	2.29	27.27	2.54	25.65	2.82	23.91	3.14	22.05	3.50	30.27	23.63	2.07	22.96	2.29	27.27	2.54	25.65	2.82	23.91	3.14	22.05	3.50
		32.74	24.80	2.09	24.11	2.31	29.54	2.56	27.80	2.83	25.95	3.15	23.97	3.51	32.74	24.80	2.09	24.11	2.31	29.54	2.56	27.80	2.83	25.95	3.15	23.97	3.51
		36.13	19.76	2.11	19.10	2.34	32.80	2.58	30.70	2.86	26.69	3.17	26.51	3.53	36.13	19.76	2.11	19.10	2.34	32.80	2.58	30.70	2.86	26.69	3.17	26.51	3.53

*At 75°F (23.9 °C) entering dry bulb—ennessee Valley Authority [IVA] rating conditions; all others at 80°F (26.7 °C) entering dry bulb. See Legend and Notes.

30 Heating Extended Performance Table -10-60 (-23.3-15.6 °C)

INDOOR AIR		OUTDOOR COIL ENTERING AIR TEMPERATURES °F (°C)																							
		-10 (-23.3)			0 (-17.8)			10 (-12.2)			20 (-6.7)			30 (-1.1)			40 (4.4)			50 (10)			60 (15.6)		
		EDB °F (°C)	CFM	Capacity MBtuh	Total Sys KW	Capacity MBtuh	Total Sys KW	Capacity MBtuh	Total Sys KW	Capacity MBtuh	Total Sys KW	Capacity MBtuh	Total Sys KW	Capacity MBtuh	Total Sys KW	Capacity MBtuh	Total Sys KW	Capacity MBtuh	Total Sys KW	Capacity MBtuh	Total Sys KW	Capacity MBtuh	Total Sys KW	Capacity MBtuh	Total Sys KW
		8.58	7.89	1.91	11.60	10.67	1.98	14.83	13.61	2.04	18.37	16.66	2.12	22.35	19.58	2.21	26.08	26.08	2.29	30.29	30.29	2.39	35.28	35.28	2.52
		8.75	8.05	1.92	11.81	10.87	1.99	15.07	13.83	2.05	18.71	16.97	2.11	22.60	19.80	2.19	26.39	26.39	2.26	30.70	30.70	2.35	35.83	35.83	2.47
		8.92	8.20	1.95	11.99	11.04	2.00	15.28	14.02	2.06	19.32	17.52	2.12	22.81	19.98	2.18	26.65	26.65	2.24	31.04	31.04	2.32	36.29	36.29	2.43
		8.06	7.42	1.98	11.12	10.23	2.06	14.37	13.19	2.13	17.90	16.23	2.21	22.07	19.33	2.31	25.74	25.74	2.40	29.87	29.87	2.50	34.73	34.73	2.64
		8.24	7.58	2.00	11.33	10.42	2.07	14.62	13.42	2.14	18.19	16.49	2.20	22.30	19.54	2.29	26.03	26.03	2.36	30.27	30.27	2.46	35.27	35.27	2.58
		8.40	7.73	2.02	11.51	10.59	2.09	14.83	13.61	2.15	18.43	16.71	2.21	22.51	19.72	2.28	26.29	26.29	2.35	30.57	30.57	2.43	35.70	35.70	2.54
		7.50	6.90	2.06	10.60	9.76	2.15	13.88	12.74	2.22	17.41	15.79	2.31	21.72	19.03	2.42	25.38	25.38	2.51	29.46	29.46	2.62	34.18	34.18	2.75
		7.68	7.06	2.08	10.81	9.95	2.16	14.13	12.97	2.23	17.69	16.05	2.30	21.99	19.27	2.40	25.68	25.68	2.48	29.83	29.83	2.57	34.70	34.70	2.69
		7.84	7.21	2.11	11.00	10.12	2.18	14.34	13.16	2.24	17.94	16.27	2.30	22.21	19.46	2.39	25.93	25.93	2.46	30.13	30.13	2.54	35.14	35.14	2.66

PERFORMANCE DATA (CONT)

36 Cooling Extended Performance Table

EVAPORATOR AIR		CONDENSER ENTERING AIR TEMPERATURES °F (°C)																	
		75 (23.9)			85 (29.4)			95 (35)			105 (40.5)			115 (46.1)			125 (51.7)		
		Capacity MBtuh	Total Sys KW	Sens	Capacity MBtuh	Total Sys KW	Sens	Capacity MBtuh	Total Sys KW	Sens	Capacity MBtuh	Total Sys KW	Sens	Capacity MBtuh	Total Sys KW	Sens	Capacity MBtuh	Total Sys KW	Sens
1050 / 0.12	57 (13.9)	33.59	2.41	32.25	2.67	30.82	2.96	29.24	29.24	29.24	29.24	27.50	3.66	25.58	25.58	25.58	25.58	25.58	4.08
	62 (16.7)	34.77	2.42	29.87	2.67	31.33	2.96	29.46	29.46	29.46	29.46	27.56	3.66	25.82	25.82	25.82	25.82	25.82	4.08
	63* (17.2)	35.34	2.42	24.23	2.68	31.81	2.96	29.83	29.83	29.83	29.83	21.55	3.66	25.33	25.33	25.33	25.33	25.33	4.08
	67 (19.4)	38.13	2.44	25.28	2.70	34.33	2.99	32.20	32.20	32.20	32.20	22.59	3.68	27.36	27.36	27.36	27.36	27.36	4.10
	72 (13.9)	41.96	2.47	39.94	2.74	37.75	3.03	35.39	35.39	35.39	35.39	18.70	3.71	30.05	30.05	30.05	30.05	30.05	4.12
	57 (13.9)	35.11	2.47	33.69	2.73	32.14	3.02	30.45	30.45	30.45	30.45	30.45	28.57	3.71	26.49	26.49	26.49	26.49	4.14
	62 (16.7)	35.71	2.47	33.97	2.73	32.20	3.02	30.50	30.50	30.50	30.50	30.50	28.61	3.71	26.53	26.53	26.53	26.53	4.14
1200 / 0.18	63* (17.2)	36.21	2.47	26.69	2.73	32.47	3.02	30.40	30.40	30.40	30.40	24.10	3.71	25.72	25.72	25.72	25.72	25.72	4.13
	67 (19.4)	38.99	2.50	37.07	2.76	35.00	3.04	32.76	32.76	32.76	25.27	3.73	27.71	27.71	27.71	27.71	27.71	4.15	
	72 (13.9)	42.86	2.53	40.74	2.79	38.42	3.08	35.93	35.93	35.93	19.82	3.76	30.40	30.40	30.40	30.40	30.40	4.17	
	57 (13.9)	36.41	2.52	34.89	2.78	33.23	3.07	31.42	31.42	31.42	31.42	29.41	3.77	27.22	27.22	27.22	27.22	4.19	
	62 (16.7)	36.54	2.53	34.95	2.79	33.28	3.07	31.47	31.47	31.47	31.47	29.45	3.77	27.25	27.25	27.25	27.25	4.19	
	63* (17.2)	36.85	2.53	34.96	2.78	32.97	3.07	30.82	30.82	30.82	30.82	25.61	3.76	26.00	26.00	26.00	26.00	4.18	
	67 (19.4)	39.63	2.55	37.64	2.81	35.49	3.10	33.16	33.16	33.16	33.16	26.89	3.78	27.98	27.98	27.98	27.98	4.20	
72 (13.9)	43.50	2.58	41.27	2.85	38.89	3.13	36.32	36.32	36.32	36.32	20.81	3.82	30.82	30.82	30.82	30.82	4.22		

*AT 75°F (23.9 °C) entering dry bulb—Tennessee Valley Authority [TVA] rating conditions; all others at 80°F (26.7 °C) entering dry bulb. See Legend and Notes.

36 Heating Extended Performance Table -10-60 (-23.3-15.6 °C)

INDOOR AIR		OUTDOOR COIL ENTERING AIR TEMPERATURES °F (°C)																							
		-10 (-23.3)			0 (-17.8)			10 (-12.2)			20 (-6.7)			30 (-1.1)			40 (4.4)			50 (10)			60 (15.6)		
		Capacity MBtuh	Total Sys KW	Sens	Capacity MBtuh	Total Sys KW	Sens	Capacity MBtuh	Total Sys KW	Sens	Capacity MBtuh	Total Sys KW	Sens	Capacity MBtuh	Total Sys KW	Sens	Capacity MBtuh	Total Sys KW	Sens	Capacity MBtuh	Total Sys KW	Sens	Capacity MBtuh	Total Sys KW	Sens
65	1050	12.15	11.18	2.30	15.31	14.08	2.39	19.19	17.61	2.49	22.68	20.57	2.58	26.68	23.38	2.68	31.28	28.00	2.80	36.70	33.40	2.96	42.99	39.70	3.16
	1200	12.38	11.39	2.32	15.57	14.32	2.40	19.41	17.82	2.50	22.96	20.82	2.58	27.01	23.66	2.67	31.68	28.38	2.78	37.20	33.90	2.94	43.06	39.76	3.12
	1350	12.59	11.58	2.35	15.79	14.53	2.43	19.62	18.01	2.52	23.19	21.03	2.59	27.29	23.91	2.75	32.01	28.71	2.83	37.51	34.21	2.93	42.82	39.52	3.10
70	1050	11.71	10.77	2.41	14.88	13.69	2.50	18.76	17.22	2.61	22.39	20.31	2.70	26.32	23.06	2.80	30.81	28.00	2.93	36.14	33.40	3.09	42.42	39.72	3.31
	1200	11.94	10.99	2.44	15.13	13.93	2.52	19.13	17.55	2.62	22.65	20.54	2.70	26.63	23.34	2.79	31.21	28.40	2.91	36.62	33.90	3.06	42.62	39.92	3.25
	1350	12.15	11.18	2.47	15.37	14.14	2.54	19.35	17.76	2.64	22.88	20.75	2.71	26.91	23.58	2.80	31.54	28.80	2.91	37.00	34.30	3.06	42.49	39.79	3.24
75	1050	11.23	10.33	2.53	14.42	13.27	2.62	18.01	16.53	2.72	22.09	20.03	2.84	25.96	22.75	2.94	30.36	27.58	3.06	35.58	32.80	3.23	41.77	39.03	3.46
	1200	11.46	10.55	2.56	14.68	13.51	2.64	18.31	16.81	2.73	22.36	20.27	2.83	26.27	23.02	2.92	30.74	28.00	3.04	36.04	33.30	3.19	42.15	39.40	3.40
	1350	11.67	10.74	2.59	14.91	13.72	2.67	18.61	17.08	2.75	22.59	20.48	2.84	26.53	23.24	2.93	31.07	28.30	3.03	36.43	33.70	3.19	42.11	39.38	3.38

PERFORMANCE DATA (CONT)
42 Cooling Extended Performance Table

EVAPORATOR AIR		CONDENSER ENTERING AIR TEMPERATURES °F (°C)																	
		75 (23.9)			85 (29.4)			95 (35)			105 (40.5)			115 (46.1)			125 (51.7)		
		Capacity MBtuh		Total Sys KW	Capacity MBtuh		Total Sys KW	Capacity MBtuh		Total Sys KW	Capacity MBtuh		Total Sys KW	Capacity MBtuh		Total Sys KW	Capacity MBtuh		Total Sys KW
CFM / BF	EWB °F (°C)	Total	Sens	Total	Sens	Total	Sens	Total	Sens	Total	Sens	Total	Sens	Total	Sens	Total	Sens	Total	Sens
		1225 / 0.14	57 (13.9)	38.29	38.29	2.70	36.78	36.78	3.00	35.17	35.17	3.35	33.43	33.43	3.76	31.55	31.55	4.23	29.53
62 (16.7)	39.60		35.26	2.71	37.74	34.27	3.01	35.79	33.19	3.36	33.74	32.00	3.76	31.62	31.62	4.24	29.58	29.58	4.78
63* (17.2)	40.17		28.70	2.72	38.23	27.80	3.02	36.20	26.84	3.37	34.04	25.81	3.77	31.75	24.73	4.24	29.30	23.57	4.77
67 (19.4)	43.43		29.99	2.76	41.34	29.07	3.07	39.13	28.10	3.42	36.80	27.07	3.83	34.33	25.98	4.30	31.69	24.82	4.85
72 (13.9)	47.71		24.52	2.83	45.36	23.64	3.14	42.91	22.89	3.50	40.34	21.70	3.91	37.63	20.65	4.40	34.75	19.54	4.95
57 (13.9)	40.11		40.11	2.76	38.48	38.48	3.06	36.73	36.73	3.42	34.85	34.85	3.83	32.83	32.83	4.31	30.65	30.65	4.86
62 (16.7)	40.77		37.93	2.77	38.83	36.81	3.07	36.82	36.82	3.42	34.91	34.91	3.83	32.88	32.88	4.31	30.69	30.69	4.86
1400 / 0.17	63* (17.2)	41.23	30.65	2.77	39.19	29.70	3.07	37.04	28.70	3.42	34.77	27.63	3.83	32.38	26.48	4.29	29.83	25.25	4.83
	67 (19.4)	44.54	32.09	2.82	42.33	31.12	3.12	40.00	30.10	3.48	37.55	29.02	3.89	34.97	27.89	4.37	32.23	26.64	4.91
	72 (13.9)	48.87	25.87	2.89	46.39	24.92	3.20	43.82	23.93	3.56	41.13	22.89	3.98	38.30	21.80	4.46	35.30	20.64	5.02
	57 (13.9)	41.67	41.67	2.82	39.92	39.92	3.13	38.04	38.04	3.48	36.04	36.04	3.90	33.89	33.89	4.38	31.57	31.57	4.93
	62 (16.7)	41.78	41.78	2.82	40.00	40.00	3.13	38.10	38.10	3.49	36.09	36.09	3.90	33.94	33.94	4.38	31.61	31.61	4.94
	63* (17.2)	42.07	32.53	2.83	39.93	31.53	3.13	37.70	30.48	3.48	35.35	29.35	3.88	32.87	28.13	4.35	30.26	26.81	4.89
	67 (19.4)	45.42	34.11	2.87	43.10	33.11	3.18	40.66	32.04	3.53	38.14	30.89	3.95	35.47	29.68	4.43	32.65	28.36	4.97
72 (13.9)	49.79	27.12	2.95	47.20	26.14	3.26	44.53	25.11	3.62	41.74	24.03	4.04	38.81	22.90	4.53	35.71	21.70	5.08	

*AT 75°F (23.9 °C) entering dry bulb—Tennessee Valley Authority [TVA] rating conditions; all others at 80°F (26.7 °C) entering dry bulb. See Legend and Notes.

42 Heating Extended Performance Table -10-60 (-23.3-15.6°C)

INDOOR AIR		OUTDOOR COIL ENTERING AIR TEMPERATURES °F (°C)																							
		-10 (-23.3)			0 (-17.8)			10 (-12.2)			20 (-6.7)			30 (-1.1)			40 (4.4)			50 (10)			60 (15.6)		
		Capacity MBtuh		Total Sys KW	Capacity MBtuh		Total Sys KW	Capacity MBtuh		Total Sys KW	Capacity MBtuh		Total Sys KW	Capacity MBtuh		Total Sys KW	Capacity MBtuh		Total Sys KW	Capacity MBtuh		Total Sys KW	Capacity MBtuh		Total Sys KW
EDB °F (°C)	CFM	Total	Integ	Total	Integ	Total	Integ	Total	Integ	Total	Integ	Total	Integ	Total	Integ	Total	Integ	Total	Integ	Total	Integ	Total	Integ		
		65	1225	13.54	12.46	2.47	17.47	16.08	2.63	21.96	21.78	2.78	25.98	23.56	2.88	30.54	26.76	2.98	35.78	35.78	3.11	42.01	42.01	3.30	48.77
1400	13.72		12.62	2.48	17.88	16.26	2.64	22.14	20.32	2.77	26.21	23.77	2.86	30.85	27.03	2.95	36.18	36.18	3.07	42.43	42.43	3.24	48.15	48.15	3.46
1575	13.88		12.77	2.50	17.85	16.43	2.65	22.30	20.47	2.78	26.41	23.95	2.86	31.10	27.25	2.95	36.50	36.50	3.17	42.12	42.12	3.22	47.19	47.19	3.42
70	1225	13.21	12.15	2.61	17.11	15.75	2.77	21.74	19.96	2.92	25.70	23.30	3.02	30.15	26.42	3.12	35.27	35.27	3.25	41.37	41.37	3.44	48.32	48.32	3.70
	1400	13.40	12.33	2.62	17.33	15.95	2.78	21.94	20.14	2.91	25.93	23.52	3.00	30.45	26.68	3.10	35.67	35.67	3.22	41.86	41.86	3.40	47.84	47.84	3.62
	1575	13.57	12.48	2.64	17.52	16.12	2.79	22.13	20.31	2.92	26.14	23.71	3.09	30.72	26.91	3.09	35.97	35.97	3.21	41.84	41.84	3.37	47.03	47.03	3.59
75	1225	12.79	11.77	2.75	16.70	15.37	2.91	21.03	19.31	3.05	25.41	23.05	3.17	29.76	26.07	3.27	34.76	34.76	3.41	40.75	40.75	3.61	47.80	47.80	3.89
	1400	12.99	11.95	2.76	16.93	15.58	2.92	21.59	19.82	3.05	25.64	23.25	3.15	30.06	26.34	3.24	35.15	35.15	3.37	41.24	41.24	3.56	47.49	47.49	3.80
	1575	13.17	12.12	2.79	17.13	15.76	2.93	21.86	20.07	3.08	25.85	23.44	3.15	30.31	26.56	3.23	35.46	35.46	3.35	41.48	41.48	3.53	46.79	46.79	3.76

PERFORMANCE DATA (CONT)
48 Cooling Extended Performance Table

EVAPORATOR AIR		CONDENSER ENTERING AIR TEMPERATURES °F (°C)																	
		75 (23.9)			85 (29.4)			95 (35)			105 (40.5)			115 (46.1)			125 (51.7)		
		CFM / BF	EWB °F (°C)	Capacity MBtuh		Total Sys KW	Capacity MBtuh		Total Sys KW	Capacity MBtuh		Total Sys KW	Capacity MBtuh		Total Sys KW	Capacity MBtuh		Total Sys KW	
Total	Sens			Total	Sens		Total	Sens		Total	Sens		Total	Sens					
1400 / 0.15	57 (13.9)	45.56	45.56	3.20	43.64	43.64	3.58	41.62	41.62	3.98	39.47	39.47	4.41	37.15	37.15	4.90	34.64	34.64	5.46
	62 (16.7)	47.12	41.32	3.21	44.75	40.06	3.59	42.33	38.74	3.99	39.81	37.27	4.42	37.23	37.23	4.91	34.69	34.69	5.46
	63* (17.2)	47.82	33.66	3.21	45.36	32.52	3.59	42.84	31.34	3.99	40.19	30.11	4.42	37.38	28.81	4.91	34.39	27.41	5.46
	67 (19.4)	51.57	35.10	3.22	48.88	33.93	3.62	46.13	32.74	4.02	43.25	31.49	4.46	40.21	30.17	4.95	36.94	28.75	5.49
	72 (13.9)	56.55	28.57	3.23	53.52	27.50	3.64	50.45	26.34	4.06	47.26	25.12	4.51	43.85	23.83	4.99	40.27	22.48	5.53
	57 (13.9)	47.60	47.60	3.26	45.50	45.50	3.65	43.31	43.31	4.05	40.98	40.98	4.49	38.48	38.48	4.98	35.76	35.76	5.53
	62 (16.7)	48.40	44.34	3.26	45.91	42.93	3.65	43.41	43.41	4.05	41.04	41.04	4.49	38.53	38.53	4.98	35.81	35.81	5.53
	63* (17.2)	48.97	35.87	3.27	46.36	34.67	3.65	43.69	33.44	4.05	40.92	32.15	4.49	37.98	30.76	4.97	34.88	29.27	5.52
	67 (19.4)	52.75	37.49	3.27	49.90	36.26	3.68	47.00	35.00	4.09	43.98	33.69	4.52	40.79	32.28	5.01	37.41	30.77	5.55
	72 (13.9)	57.75	30.14	3.28	54.58	28.93	3.70	51.36	27.71	4.13	48.01	26.44	4.57	44.45	25.09	5.06	40.74	23.89	5.59
1600 / 0.18	57 (13.9)	49.32	49.32	3.32	47.06	47.06	3.71	44.71	44.71	4.12	42.23	42.23	4.56	39.55	39.55	5.05	36.65	36.65	5.59
	62 (16.7)	49.55	49.16	3.32	47.14	47.14	3.71	44.77	44.77	4.12	42.28	42.28	4.56	39.60	39.60	5.05	36.70	36.70	5.59
	63* (17.2)	49.85	38.00	3.32	47.12	36.74	3.71	44.35	35.44	4.11	41.47	34.07	4.55	38.44	32.60	5.03	35.24	30.98	5.57
	67 (19.4)	53.64	39.78	3.32	50.67	38.49	3.73	47.66	37.17	4.15	44.52	35.78	4.59	41.22	34.28	5.07	37.75	32.65	5.60
	72 (13.9)	58.69	31.53	3.33	55.39	30.29	3.76	52.04	29.02	4.18	48.54	27.70	4.63	44.88	26.31	5.12	41.06	24.85	5.65

*At 75°F (23.9°C) entering dry bulb—Tennessee Valley Authority [VA] rating conditions; all others at 80°F (26.7°C) entering dry bulb. See Legend and Notes.

48 Heating Extended Performance Table -10-60 (-23.3-15.6°C)

INDOOR AIR		OUTDOOR COIL ENTERING AIR TEMPERATURES °F (°C)																							
		-10 (-23.3)			0 (-17.8)			10 (-12.2)			20 (-6.7)			30 (-1.1)			40 (4.4)			50 (10)			60 (15.6)		
		EDB °F (°C)	CFM	Capacity MBtuh		Total Sys KW	Capacity MBtuh		Total Sys KW	Capacity MBtuh		Total Sys KW	Capacity MBtuh		Total Sys KW	Capacity MBtuh		Total Sys KW	Capacity MBtuh		Total Sys KW				
Total	Integ			Total	Integ		Total	Integ		Total	Integ		Total	Integ		Total	Integ								
65 (18.3)	1400	15.76	14.50	2.95	20.36	18.74	3.07	25.22	23.15	3.20	31.05	28.16	3.36	36.22	31.73	3.50	41.94	41.94	3.65	48.55	48.55	3.83	56.41	56.41	4.05
	1800	16.01	14.73	2.98	20.64	18.99	3.09	25.55	23.46	3.21	31.36	28.44	3.35	36.59	32.06	3.48	42.42	42.42	3.61	49.17	49.17	3.77	57.12	57.12	3.95
	1800	16.24	14.94	3.02	20.90	19.23	3.12	25.85	23.73	3.23	31.63	28.69	3.38	36.92	32.35	3.48	42.84	42.84	3.60	49.72	49.72	3.74	57.48	57.48	3.90
70 (21.1)	1400	15.26	14.04	3.08	19.85	18.27	3.20	24.68	22.85	3.33	30.13	27.92	3.48	35.80	31.37	3.65	41.40	41.40	3.81	47.87	47.87	4.00	55.58	55.58	4.24
	1800	15.52	14.28	3.11	20.14	18.53	3.22	25.04	22.98	3.34	30.99	28.11	3.50	36.16	31.68	3.63	41.87	41.87	3.78	48.48	48.48	3.94	56.38	56.38	4.15
	1800	15.76	14.50	3.15	20.41	18.78	3.25	25.33	23.25	3.36	31.28	28.37	3.51	36.49	31.97	3.63	42.28	42.28	3.76	49.01	49.01	3.91	56.82	56.82	4.09
75 (23.9)	1400	14.68	13.51	3.22	19.29	17.74	3.34	24.12	22.14	3.47	29.34	26.61	3.63	35.38	31.00	3.82	40.85	40.85	3.98	47.21	47.21	4.18	54.77	54.77	4.43
	1800	14.95	13.76	3.25	19.59	18.03	3.36	24.47	22.46	3.48	29.76	26.99	3.62	35.73	31.31	3.79	41.31	41.31	3.94	47.80	47.80	4.12	55.56	55.56	4.35
	1800	15.19	13.98	3.29	19.85	18.27	3.39	24.78	22.74	3.51	30.19	27.38	3.63	36.07	31.60	3.79	41.72	41.72	3.93	48.30	48.30	4.09	56.12	56.12	4.28

PERFORMANCE DATA (CONT) 60 Cooling Extended Performance Table

EVAPORATOR AIR		CONDENSER ENTERING AIR TEMPERATURES °F (°C)																	
		75 (23.9)			85 (29.4)			95 (35)			105 (40.5)			115 (46.1)			125 (51.7)		
		Capacity MBtuh	Total Sys KW	Sens	Capacity MBtuh	Total Sys KW	Sens	Capacity MBtuh	Total Sys KW	Sens	Capacity MBtuh	Total Sys KW	Sens	Capacity MBtuh	Total Sys KW	Sens	Capacity MBtuh	Total Sys KW	Sens
1750 / 0.19	57 (13.9)	56.42	3.97	54.09	4.39	51.60	4.86	48.89	5.40	45.87	6.01	42.60	6.70	39.25	7.10	36.06	8.00	32.26	8.90
	62 (16.7)	58.00	3.99	55.15	4.40	52.19	4.87	49.10	5.40	45.94	6.01	42.66	6.70	38.67	7.10	35.94	8.00	32.26	8.90
	63* (17.2)	58.78	4.00	55.87	4.41	52.77	4.88	49.45	5.41	45.84	6.01	42.01	6.69	38.06	7.10	35.06	8.00	32.26	8.90
	67 (19.4)	63.34	4.05	60.17	4.47	56.78	4.94	49.27	5.46	49.23	6.06	45.09	6.74	37.77	7.10	35.96	8.00	32.26	8.90
	72 (13.9)	69.39	4.13	65.81	4.55	62.02	5.02	51.19	5.54	53.69	6.13	49.14	6.80	42.88	7.10	39.56	8.00	32.26	8.90
	57 (13.9)	56.94	3.99	54.57	4.41	52.03	4.88	49.27	5.42	46.23	6.03	42.88	6.72	39.56	7.10	35.96	8.00	32.26	8.90
	62 (16.7)	58.33	4.01	55.44	4.42	52.47	4.89	49.36	5.42	46.30	6.03	42.94	6.72	39.56	7.10	35.96	8.00	32.26	8.90
1850 / 0.20	63* (17.2)	59.07	4.02	56.12	4.43	53.00	4.90	49.63	5.42	45.98	6.03	42.13	6.71	38.25	7.10	35.74	8.00	32.26	8.90
	67 (19.4)	63.63	4.08	60.42	4.49	57.00	4.96	53.31	5.48	49.37	6.08	45.20	6.75	40.02	7.10	38.31	8.00	32.26	8.90
	72 (13.9)	69.68	4.15	66.07	4.57	62.25	5.04	58.17	5.56	53.84	6.15	49.25	6.82	42.88	7.10	39.56	8.00	32.26	8.90
	57 (13.9)	60.87	4.19	58.14	4.61	55.23	5.08	52.05	5.62	48.61	6.22	44.88	6.90	40.02	7.10	38.31	8.00	32.26	8.90
	62 (16.7)	60.95	4.19	58.23	4.61	55.31	5.08	52.12	5.62	48.67	6.22	44.93	6.90	40.02	7.10	38.31	8.00	32.26	8.90
	63* (17.2)	61.07	4.19	57.83	4.61	54.45	5.07	50.81	5.60	46.95	6.19	42.89	6.87	40.02	7.10	38.31	8.00	32.26	8.90
	67 (19.4)	65.61	4.25	62.14	4.67	58.42	5.13	54.47	5.66	50.28	6.25	45.90	6.92	40.02	7.10	38.31	8.00	32.26	8.90
72 (13.9)	71.73	4.33	67.82	4.75	63.70	5.21	59.34	5.74	54.72	6.32	49.88	6.98	40.02	7.10	38.31	8.00	32.26	8.90	

*At 75°F (23.9 °C) entering dry bulb—Tennessee Valley Authority [TVA] rating conditions; all others at 80°F (26.7 °C) entering dry bulb. See Legend and Notes.

60 Heating Extended Performance Table -10-60 (-23.3-15.6 °C)

INDOOR AIR		OUTDOOR COIL ENTERING AIR TEMPERATURES °F (°C)																							
		-10 (-23.3)			0 (-17.8)			10 (-12.2)			20 (-6.7)			30 (-1.1)			40 (4.4)			50 (10)			60 (15.6)		
		Capacity MBtuh	Total Sys KW	Sens	Capacity MBtuh	Total Sys KW	Sens	Capacity MBtuh	Total Sys KW	Sens	Capacity MBtuh	Total Sys KW	Sens	Capacity MBtuh	Total Sys KW	Sens	Capacity MBtuh	Total Sys KW	Sens	Capacity MBtuh	Total Sys KW	Sens			
65	1750	19.26	17.72	3.62	24.88	22.89	3.77	30.79	28.26	3.91	37.20	33.74	4.06	44.98	39.41	4.26	51.96	45.43	4.43	60.02	50.02	4.64	69.62	58.82	4.91
	1800	19.34	17.79	3.63	24.98	22.98	3.78	30.90	28.37	3.92	37.33	33.85	4.07	45.09	39.50	4.26	52.09	45.42	4.42	60.19	50.19	4.62	69.84	59.04	4.89
	2250	20.06	18.45	3.75	25.74	23.69	3.88	31.75	29.14	4.00	38.31	34.75	4.12	45.93	40.25	4.28	53.12	45.41	4.41	61.48	51.48	4.58	71.51	61.51	4.81
70	1750	18.37	16.90	3.77	24.01	22.09	3.92	30.00	27.54	4.08	36.36	32.98	4.24	44.47	38.96	4.46	51.32	45.43	4.63	59.22	59.22	4.85	68.63	58.63	5.12
	1800	18.45	16.97	3.78	24.11	22.18	3.93	30.11	27.64	4.09	36.49	33.09	4.24	44.58	39.06	4.45	51.43	45.43	4.63	59.39	59.39	4.85	68.85	58.85	5.10
	2250	19.15	17.62	3.90	24.92	22.93	4.04	30.96	28.41	4.17	37.44	33.95	4.30	45.42	39.80	4.47	52.45	46.41	4.61	60.65	60.65	4.79	70.47	60.47	5.02
75	1750	17.44	16.04	3.93	23.12	21.27	4.09	29.18	26.78	4.26	35.57	32.26	4.43	43.08	37.74	4.63	50.66	45.44	4.85	58.44	58.44	5.07	67.67	57.67	5.35
	1800	17.52	16.12	3.94	23.22	21.36	4.10	29.28	26.88	4.27	35.70	32.37	4.43	43.34	37.97	4.64	50.78	45.44	4.84	58.60	58.60	5.05	67.87	57.87	5.33
	2250	18.19	16.73	4.06	23.99	22.07	4.21	30.13	27.65	4.35	36.62	33.31	4.48	44.87	39.31	4.68	51.79	46.41	4.82	59.83	59.83	5.00	69.45	59.45	5.24

LEGEND

- BF — Bypass Factor
- edb — Entering Dry – Bulb
- EWb — Entering Wet – Bulb
- kw — Total Unit Power Input
- SHC — Sensible Heat Capacity (1000 Btuh)
- TC — Total Capacity (1000 Btuh) (net)
- rh — Relative Humidity

COOLING NOTES:

1. Ratings are net; they account for the effects of the evaporator – fan motor power and heat.
2. Direct interpolation is permissible. Do not extrapolate.
3. The following formulas may be used:

$$t_{db} = t_{edb} - \frac{\text{Sensible capacity (Btuh)}}{1,10 \times \text{cfm}}$$

$$t_{wb} = \text{Wet-bulb temperature corresponding to enthalpy of air leaving evaporator coil (} t_{lwb} \text{)}$$

$$h_{lwb} = h_{ewb} - \frac{\text{total capacity (Btuh)}}{4.5 \times \text{cfm}}$$

Where: h_{ewb} = Enthalpy of air entering evaporator coil

4. The SHC is based on 80°F (26.7 °C) edb temperature of air entering evaporator coil. Below 80°F (26.7°C) edb, subtract (corr factor x cfm) from SHC. Above 80°F (26.7°C) edb, add (corr factor x cfm) to SHC. Correction Factor = 1,10 x (1 + BF) x (edb – 80).

5. Integrated capacity is maximum (instantaneous) capacity less the effect of frost on the outdoor coil and the heat required to defrost it.

PERFORMANCE DATA (CONT)

Wet Coil Air Delivery (CFM)- Downflow - High Speed with 1-in. (25 mm) Filter and Economizer

UNIT SIZE	EXTERNAL STATIC PRESSURE (IN. W.C.)									
	0.1	0.2	0.3	0.4	0.5	0.6	0.7	0.8	0.9	1.0
36	1333	1289	1256	1214	1152	1118	1076	1035	997	950
42	1612	1569	1527	1481	1451	1393	1351	1317	1278	1242
48	2166	2085	2002	1919	1798	1709	1582	1467	1270	988
60	2298	2239	2180	2110	2044	1951	1862	1777	1697	1591

Economizer 1-in. Filter Pressure Drop (IN. W.C.)

UNIT/PH3G--A	PRESSURE DROP
24-36	0.20
42-60	0.25

Multiplication Factors

HEATER KW RATING	VOLTAGE DISTRIBUTION	MULTIPLICATION FACTOR
240	200	0.69
	208	0.75
	230	0.92
	240	1.00
	460	0.92
480		

Electric Heat Pressure Drop Table IN. W.C.)

Small Cabinet: 24-36 CFM

HEATER CAPACITY	STANDARD CFM (S.C.F.M)											
	500	600	700	800	900	1000	1100	1200	1300	1400	1500	1600
5kw	0.00	0.00	0.00	0.00	0.00	0.00	0.00	0.00	0.02	0.04	0.06	0.07
7.5 kw	0.00	0.00	0.00	0.00	0.00	0.00	0.02	0.03	0.05	0.07	0.08	0.09
10 kw	0.00	0.00	0.00	0.00	0.00	0.02	0.04	0.06	0.07	0.09	0.10	0.11
15 kw	0.00	0.00	0.00	0.02	0.04	0.06	0.08	0.10	0.12	0.14	0.16	0.18
20 kw	0.00	0.00	0.02	0.04	0.06	0.08	0.09	0.11	0.13	0.15	0.17	0.19

Large Cabinet 42-60 CFM

HEATER CAPACITY	STANDARD CFM (S.C.F.M)														
	1100	1200	1300	1400	1500	1600	1700	1800	1900	2000	2100	2200	2300	2400	2500
5kw	0.00	0.00	0.00	0.01	0.02	0.03	0.04	0.05	0.06	0.07	0.08	0.09	0.10	0.11	0.12
7.5 kw	0.00	0.00	0.01	0.02	0.03	0.04	0.05	0.06	0.07	0.08	0.09	0.10	0.11	0.12	0.13
10 kw	0.00	0.00	0.01	0.02	0.03	0.04	0.05	0.06	0.07	0.08	0.09	0.10	0.11	0.12	0.13
15 kw	0.00	0.02	0.03	0.04	0.05	0.06	0.07	0.08	0.09	0.10	0.11	0.12	0.13	0.14	0.15
20 kw	0.02	0.03	0.04	0.05	0.06	0.07	0.08	0.09	0.10	0.11	0.12	0.13	0.14	0.15	0.16

PH3G--A Horizontal Wet Coil Pressure Drop (IN. W.C.)

UNIT SIZE	STANDARD CFM (S.C.F.M)															
	500	600	700	800	900	1000	1100	1200	1300	1400	1500	1600	1700	1800	1900	2000
24		0.06	0.07	0.08	0.09	0.1										
30				0.12	0.15	0.19	0.23	0.27								
36						0.07	0.11	0.18	0.26	0.35						
42								0.04	0.07	0.1	0.15	0.21				
48										0.11	0.14	0.17	0.22	0.28		
60												0.1	0.17	0.23	0.31	0.36

Horizontal Filter Pressure Drop Table (IN. W.C.)

FILTER SIZE in. (mm)	STANDARD CFM (S.C.F.M)																		
	500	600	700	800	900	1000	1100	1200	1300	1400	1500	1600	1700	1800	1900	2000	2100	2200	2300
20X20X1 (508X508X25)	0.05	0.07	0.08	0.1	0.12	0.13	0.14	0.15	—	—	—	—	—	—	—	—	—	—	—
20X24X1 (508X610X25)	—	—	—	.09	.10	.11	.13	.14	.15	.16	—	—	—	—	—	—	—	—	—
24X30X1 (610X762X25)	—	—	—	0.04	0.05	0.06	0.07	0.07	0.08	0.09	0.1	—	—	—	—	—	—	—	—
24X36X1 (610X914X25)	—	—	—	—	—	—	—	0.06	0.07	0.07	0.08	0.09	0.09	0.10	0.11	0.12	0.13	0.14	0.14

Dry Coil Air Delivery* - Horizontal and Downflow Discharge - Unit PH3G--A24-60

UNIT	MOTOR SPEED	WIRE COLOR		EXTERNAL STATIC PRESSURE (IN. W.C.)									
				0.1	0.2	0.3	0.4	0.5	0.6	0.7	0.8	0.9	
PH3G--A24	Low	Blue	CFM	754	650	538	429	---	---	---	---	---	---
	Med-Low	Pink	CFM	851	777	675	591	475	---	---	---	---	---
	Medium ¹	Red	CFM	941	851	774	684	576	479	---	---	---	---
	Med-High	Orange	CFM	1009	917	840	759	667	577	447	---	---	---
	High	Black	CFM	1241	1167	1111	1036	969	881	818	731	640	---
PH3G--A30	Low	Blue	CFM	741	638	547	415	---	---	---	---	---	---
	Med-Low	Pink	CFM	973	887	823	733	665	538	451	---	---	---
	Medium ¹	Red	CFM	1088	1023	954	881	800	723	658	563	461	---
	Med-High ¹	Orange	CFM	1140	1064	996	915	840	758	687	564	480	---
	High	Black	CFM	1202	1140	1082	1015	961	881	810	732	631	---
PH3G--A36	Low	Blue	CFM	1234	1168	1093	1021	961	894	825	759	687	---
	Med-Low	Pink	CFM	1290	1223	1154	1090	1027	977	894	828	762	---
	Medium ¹	Red	CFM	1354	1290	1226	1158	1102	1046	981	918	843	---
	Med-High	Orange	CFM	1606	1546	1489	1430	1371	1316	1258	1208	1140	---
	High	Black	CFM	1630	1580	1517	1463	1407	1339	1277	1210	1131	---
PH3G--A42	Low	Blue	CFM	1295	1234	1182	1126	1075	1016	955	898	857	---
	Med-Low	Pink	CFM	1345	1282	1235	1194	1140	1095	1027	974	921	---
	Medium ¹	Red	CFM	1505	1452	1413	1358	1323	1282	1234	1169	1130	---
	Med-High ¹	Orange	CFM	1545	1492	1449	1411	1362	1313	1278	1231	1188	---
	High	Black	CFM	1705	1643	1607	1568	1518	1483	1448	1404	1360	---
PH3G--A48	Low	Blue	CFM	1402	1351	1311	1263	1224	1172	1136	1080	1041	---
	Med-Low	Pink	CFM	1457	1404	1367	1318	1284	1233	1197	1144	1104	---
	Medium ¹	Red	CFM	1736	1695	1642	1601	1553	1512	1465	1427	1381	---
	Med-High	Orange	CFM	2149	2111	2062	2026	1980	1945	1905	1864	1793	---
	High	Black	CFM	2344	2306	2259	2203	2141	2070	1991	1902	1803	---
PH3G--A60	Low	Blue	CFM	1445	1389	1341	1281	1236	1189	1139	1072	1027	---
	Med-Low	Pink	CFM	1678	1635	1602	1558	1513	1474	1438	1404	1349	---
	Medium ¹	Red	CFM	1927	1893	1858	1824	1791	1759	1720	1689	1640	---
	Med-High	Orange	CFM	2131	2088	2065	2013	1982	1941	1888	1860	1785	---
	High	Black	CFM	2461	2409	2339	2286	2192	2140	2062	1968	1874	---

* Air delivery values are without air filter and are for dry coil (See PH3G--A Horizontal Wet Coil Pressure Drop Table).

¹ Factory-shipped cooling speed

NOTE: For horizontal applications deduct field-supplied air filter pressure drop and wet coil pressure drop to obtain external static pressure available for ducting. For downflow applications see Wet Coil Air Delivery Table for available static including wet coil, 1-in. (25 mm) filter and economizer.

Shaded areas indicate speed/static combinations that are not permitted for dehumidification speed.

PH3G--A

TYPICAL PIPING AND WIRING

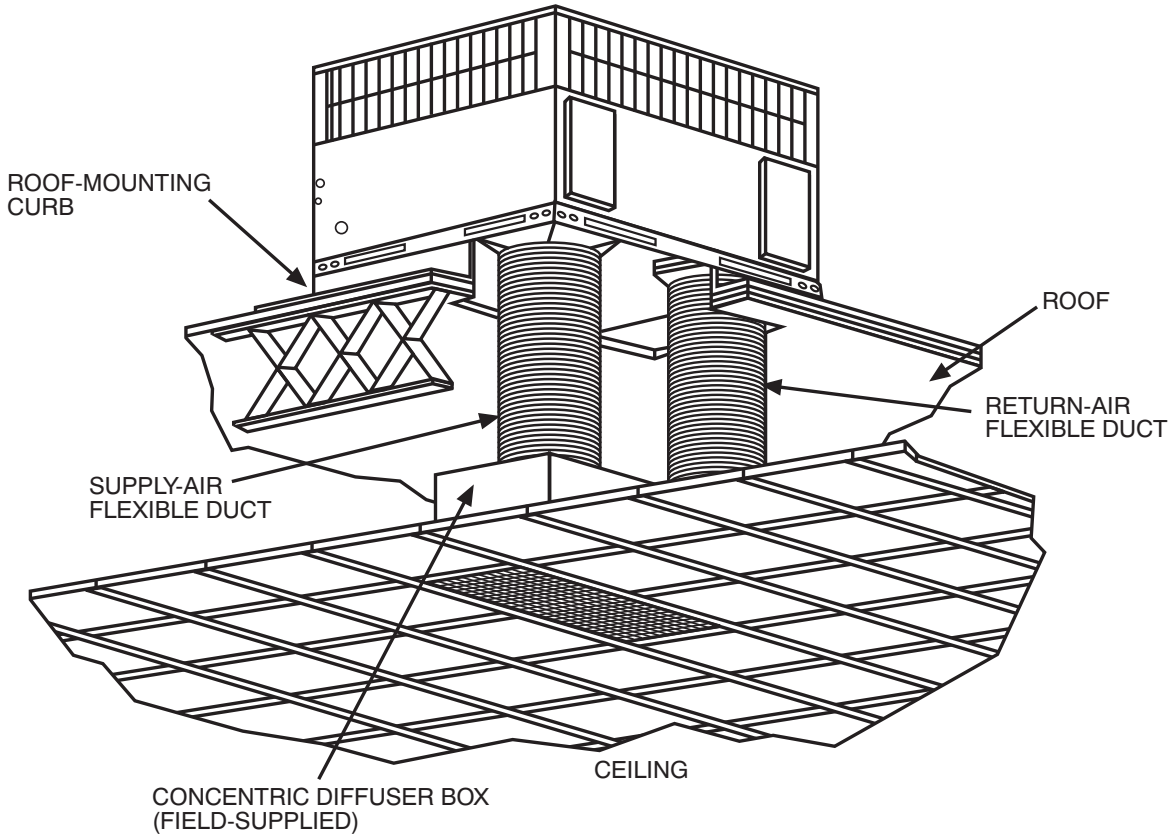

A09230

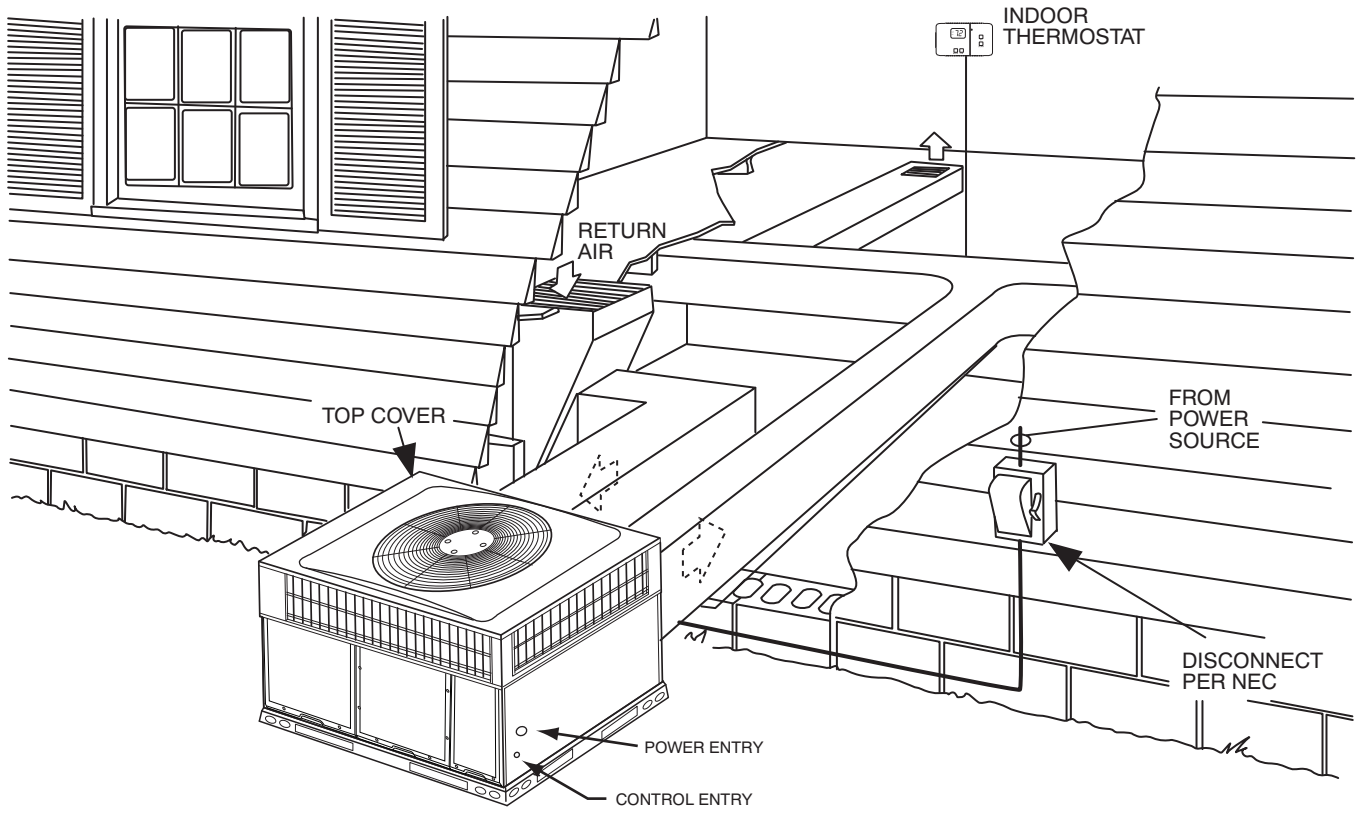

A09240

PH3G--A

APPLICATION DATA

Condensate trap — A 2-in. (51 mm) condensate trap must be field supplied.

Ductwork — Secure downflow discharge ductwork to roof curb. For horizontal discharge applications, attach ductwork to unit with flanges.

To convert a unit to downflow discharge — Units are equipped with factory-installed inserts in the downflow openings. Removal of the inserts is similar to removing an electrical knock-out. Units installed in horizontal discharge orientation do not require duct covers.

Maximum cooling airflow — To minimize the possibility of condensate blow-off from the evaporator, airflow through the units should not exceed 450 cfm per ton.

Minimum cooling airflow — Minimum cooling airflow is 350 cfm per ton in cooling mode. Airflow can be lower in certain modes when humidity removal is an issue.

Minimum ambient cooling operation temperature — All standard units have a minimum ambient cooling operating temperature of 40°F (4.4°C). With accessory low ambient temperature kit, units can operate at temperatures down to 0°F (17.8°C).

Maximum operating outdoor air temperature for cooling is 125°F (51.7°C).

BALANCE POINT WORKSHEET

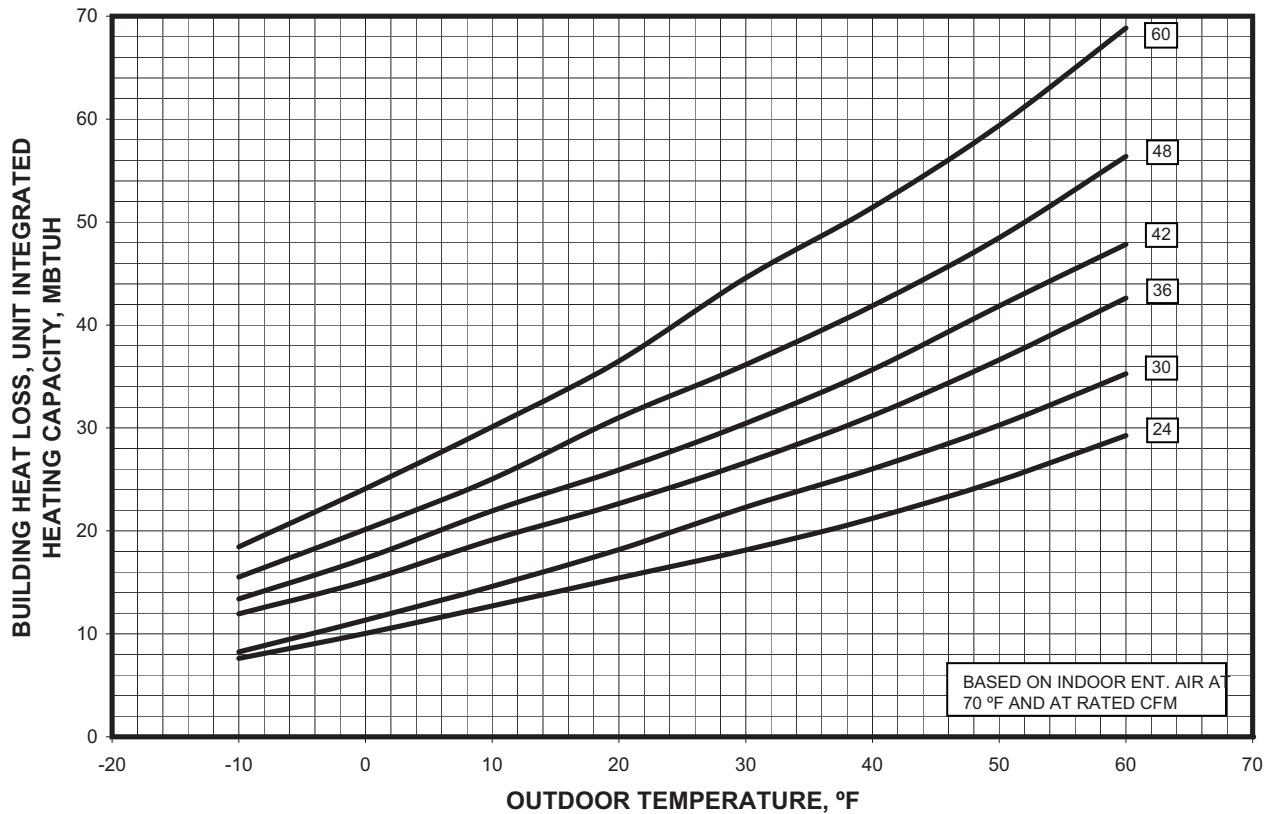

A09269

PH3G--A

ELECTRICAL DATA

PH3G--A

UNIT	NOMINAL V-PH-HZ	VOLTAGE RANGE		COMPRESSOR		OFM	IFM	ELECTRIC HEAT		POWER SUPPLY	
		MIN	MAX	RLA	LRA	FLA	FLA	NOMINAL kW	FLA	MCA	MOCP
PH3G--A24	208/230-1-60	197	253	13.5	58.3	1.2	4.1	-/-	-/-	22.2	30
								3.8/5	18.1/20.8	44.8/48.2	45/50
								5.4/7.2	25.9/30	54.6/59.7	60/60
								7.5/10	36.1/41.7	67.3/74.3	70/80
PH3G--A30	208/230-1-60	197	253	16	73	1.2	4.1	-/-	-/-	25.3	40
								3.8/5	18.1/20.8	47.9/51.3	50/60
								5.4/7.2	25.9/30	57.7/62.8	60/70
								7.5/10	36.1/41.7	70.4/77.4	80/80
	208/230-3-60	197	253	10.9	58	1.2	4.1	-/-	-/-	18.9	25
								3.8/5	10.4/12	31.9/33.9	35/35
								7.5/10	20.8/24.1	44.9/49.1	45/50
								11.3/15	31.2/36.1	57.9/64.1	60/70
PH3G--A36	208/230-1-60	197	253	19.3	79	1.2	6.0	-/-	-/-	31.3	45
								3.8/5	18.1/20.8	54/57.3	60/60
								5.4/7.2	25.9/30	63.7/68.8	70/70
								7.5/10	36.1/41.7	76.5/83.5	80/90
	208/230-3-60	197	253	13	73	1.2	6.0	-/-	-/-	23.5	30
								3.8/5	10.4/12	36.5/38.5	40/40
								7.5/10	20.8/24.1	49.5/53.6	50/60
								11.3/15	31.2/36.1	62.5/68.6	70/70
	460-3-60	414	506	6	38	0.5	3.0	-/-	-/-	11	15
								3.8/5	6	18.5/18.5	20
								7.5/10	12	26/26	30
								11.3/15	18	33.5/33.5	35
PH3G--A42	208/230-1-60	197	253	20.9	112	1.2	6.0	-/-	-/-	33.3	50
								3.8/5	18.1/20.8	56/59.3	60/60
								5.4/7.2	25.9/30	65.7/70.8	70/80
								7.5/10	36.1/41.7	78.5/85.5	80/90
	208/230-3-60	197	253	13.5	88	1.2	6.0	-/-	-/-	24.1	35
								3.8/5	10.4/12	37.1/39.1	40/40
								7.5/10	20.8/24.1	50.1/54.2	60/60
								11.3/15	31.2/36.1	63.1/69.2	70/70
	460-3-60	414	506	6.2	44	0.5	3.0	-/-	-/-	11.3	15
								3.8/5	6	18.8/18.8	20
								7.5/10	12	26.3/26.3	30
								11.3/15	18	33.8/33.8	35
PH3G--A48	208/230-1-60	197	253	23.5	117	1.2	7.6	-/-	-/-	38.2	50
								3.8/5	18.1/20.8	60.8/64.2	70/70
								5.4/7.2	25.9/30	70.6/75.7	80/80
								7.5/10	36.1/41.7	83.3/90.3	90/100
	208/230-3-60	197	253	14.8	83.1	1.2	7.6	-/-	-/-	27.3	40
								3.8/5	10.4/12	40.3/42.3	45/45
								7.5/10	20.8/24.1	53.3/57.4	60/60
								11.3/15	31.2/36.1	66.3/72.4	70/80
	460-3-60	414	506	6.5	41	0.5	3.8	15/19.91	41.4/47.9	79.1/87.2	80/90
								-/-	-/-	12.4	15
								3.8/5	6	19.9/19.9	20
								7.5/10	12	27.4/27.4	30
								11.3/15	18	34.9/34.9	35
								15/20	24.1	42.6/42.6	45

ELECTRICAL DATA (CONT)

UNIT	NOMINAL V-PH-HZ	VOLTAGE RANGE		COMPRESSOR		OFM	IFM	ELECTRIC HEAT		POWER SUPPLY	
		MIN	MAX	RLA	LRA	FLA	FLA	NOMINAL kW	FLA	MCA	MOCP
PH3G--A60	208/230-1-60	197	253	27.4	134	1.2	7.6	-/-	-/-	43.1	60
								3.8/5	18.1/20.8	65.7/69.1	70/70
								5.4/7.2	25.9/30	75.4/80.6	80/90
								7.5/10	36.1/41.7	88.2/95.2	90/100
								11.3/15	54.2/62.5	110.8/121.2	125/125
	15/20	72.2/83.3	133.3/147.2	150/150							
	208/230-3-60	197	253	18.4	110	1.2	7.6	-/-	-/-	31.8	45
								3.8/5	10.4/12	44.8/46.8	45/50
								7.5/10	20.8/24.1	57.8/61.9	60/70
								11.3/15	31.2/36.1	70.8/76.9	80/80
								15/19.91	41.4/47.9	83.6/91.7	90/100
	460-3-60	414	506	8	52	0.5	3.8	-/-	-/-	14.3	20
								3.8/5	6	21.8/21.8	25
								7.5/10	12	29.3/29.3	30
								11.3/15	18	36.8/36.8	40
15/20								24.1	44.4/44.4	45	

See Legend and Notes below.

LEGEND

- FLA -- Full Load Amps
- LRA -- Locked Rotor Amps
- MCA -- Minimum Circuit Amps
- MOCP -- Maximum Overcurrent Protection
- RLA -- Rated Load Amps

NOTES:

- In compliance with NEC (National Electrical Code) requirements for multimotor and combination load equipment (refer to NEC Articles 430 and 440), the overcurrent protective device for the unit shall be Power Supply fuse or circuit breaker.
- Minimum wire size is based on 60 C copper wire. If other than 60 C wire is used, or if length exceeds wire length in table, determine size from NEC.
- Unbalanced 3-Phase Supply Voltage
Never operate a motor where a phase imbalance in supply voltage is greater than 2%. Use the following formula to determine the percentage of voltage imbalance

$$\% \text{ Voltage imbalance} = 100 \times \frac{\text{max voltage deviation from average voltage}}{\text{average voltage}}$$

EXAMPLE: Supply voltage is 230-3-60.

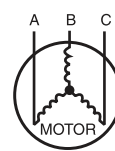

- AB = 228 v
- BC = 231 v
- AC = 227 v

$$\begin{aligned} \text{Average Voltage} &= \frac{228 + 231 + 227}{3} \\ &= \frac{686}{3} \\ &= 229 \end{aligned}$$

Determine maximum deviation from average voltage.

- (AB) 229 - 228 = 1 v
- (BC) 231 - 229 = 2 v
- (AC) 229 - 227 = 2 v

Maximum deviation is 2 v.

Determine percent of voltage imbalance

$$\begin{aligned} \% \text{ Voltage Imbalance} &= 100 \times \frac{2}{229} \\ &= 0.8\% \end{aligned}$$

This amount of phase imbalance is satisfactory as it is below the maximum allowable 2%.

IMPORTANT: If the supply voltage phase imbalance is more than 2%, contact your local electric utility company immediately.

A06564

PH3G--A

LADDER WIRING DIAGRAM
DANGER: ELECTRICAL SHOCK HAZARD DISCONNECT POWER BEFORE SERVICING

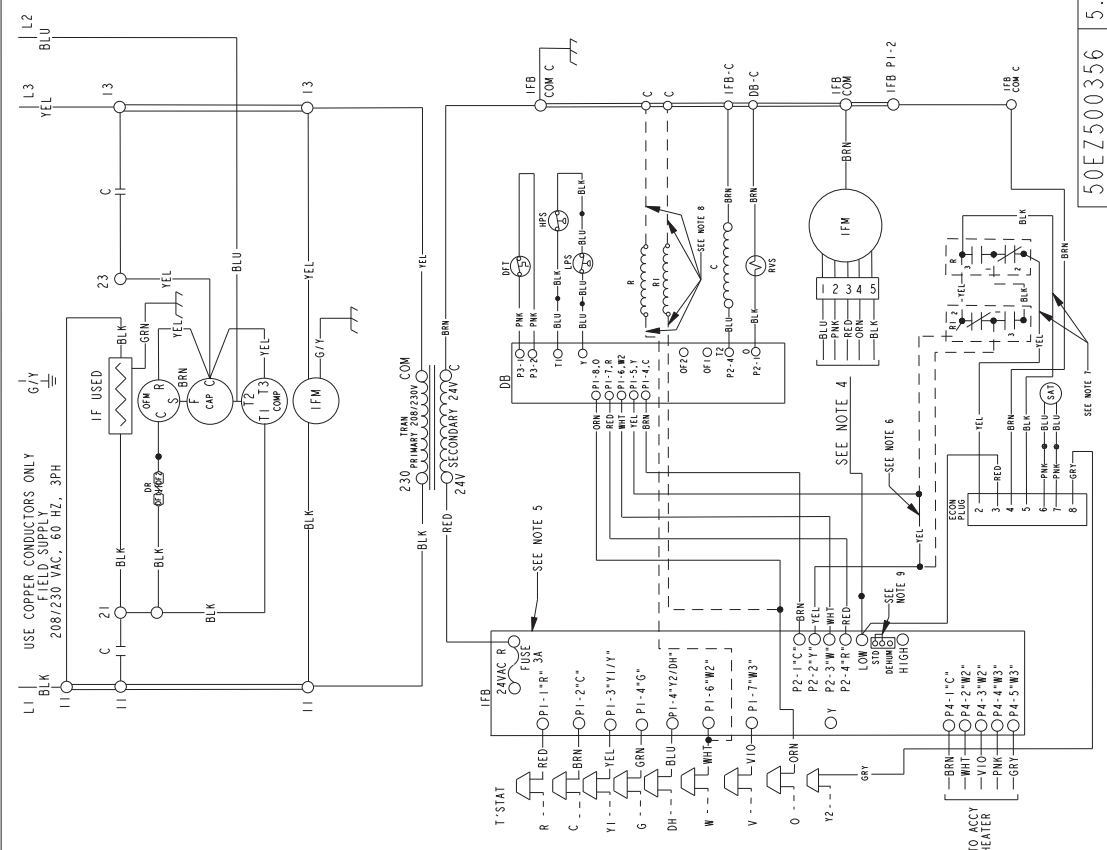

50EZ500356 5.0

CONNECTION WIRING DIAGRAM
DANGER: ELECTRICAL SHOCK HAZARD DISCONNECT POWER BEFORE SERVICING

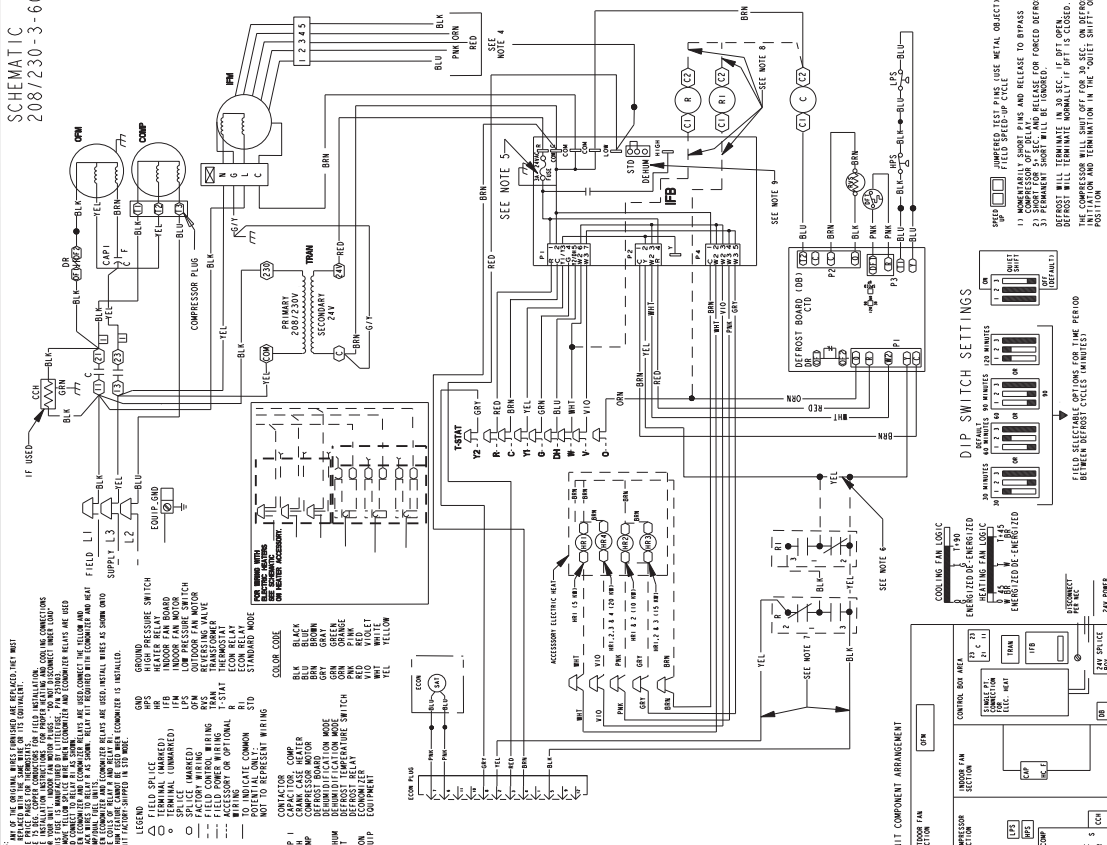

CONTROLS

Operating sequence

When power is supplied to unit, the transformer (TRAN) is energized.

On units with crankcase heater, heater is also energized.

Cooling — With the thermostat in the cooling position, the thermostat makes circuit “R” to “O”. This energizes the reversing valve solenoid (RVS) and places the unit in standby condition for cooling.

As the space temperature rises, the thermostat closes circuit “R” to “Y”. A circuit is made to contactor (C), starting the compressor (COMP) and outdoor-fan motor (OFM). Circuit “R” to “G” is made at the same time and starts the indoor-fan motor (IFM).

When the thermostat is satisfied, contacts open, deenergizing C. The COMP and OFM stop, and the IFM stops after the preselected time delay.

On the loss of the thermostat call for cooling, 24 V is removed from both the “Y1/Y” and “G” terminals (provided the fan switch is in the “AUTO” position) de-energizing the compressor contactor and opening the contacts supplying power to compressor/OFM. After a 90-second delay, the IFM shuts off. If the thermostat fan selector switch is in the “ON” position, the IFM will run continuously.

Heating — On a call for heat, thermostat makes circuits “R” to “Y” and “R” to “G”.

A circuit is made to C, starting COMP and OFM. Circuit “R” to “G” also is completed, energizing IFR and starting IFM after the selected time delay.

Should room temperature continue to fall, circuit “R” to “W” is made through second-stage thermostat. If optional electric heat package is used, a relay is energized, bringing on first bank of supplemental electric heat. When thermostat is satisfied, contacts open, deenergizing contactor and relay; motors and heaters deenergize.

Defrost — Defrost board (DB) is a time and temperature control, which includes a field-selectable time period (dip switch 1 and 2 on the board) between checks for defrost (30, 60, 90, or 120 minutes). Electronic timer and defrost cycle start only when contactor is energized and defrost thermostat (DFT) is closed.

The defrost board is also equipped with a third dip switch for selecting Quiet Shift operation. The Quiet Shift operation turns compressor off at defrost initiation and termination. Unit is factory shipped with quiet shift turned off.

Defrost mode is identical to cooling mode, except outdoor fan motor stops and a bank of optional electric heat turns on to warm air supplying the conditioned space.

NOTE:

1. Compressor time delay occurs through the defrost control board.
2. Defrost control board has built in 5 minute compressor delay; once the compressor has started and then stopped, it cannot be restarted again until 5 minutes have elapsed.

GUIDE SPECIFICATIONS

Packaged Heat Pumps

HVAC Guide Specifications

Size Range: **2 to 5 Tons, Nominal Cooling**

Model Number: **PH3G--A**

Part 1—General

SYSTEM DESCRIPTION

Outdoor, packaged, air-to-air heat pump unit utilizing a hermetic scroll compressor for cooling duty and optional electric heating. Unit shall discharge supply air vertically or horizontally as shown on contract drawings. Outdoor fan/coil section shall have a draw-thru design with vertical discharge for minimum sound levels.

QUALITY ASSURANCE

- A. Unit shall be rated in accordance with ARI Standards 210/240 and 270.
- B. Unit shall be designed in accordance with UL Standard 1995.
- C. Unit shall be manufactured in a facility registered to ISO 9001 manufacturing quality standard.
- D. Unit shall be UL listed and c-UL certified as a total package for safety requirements.
- E. Roof curb shall be designed to conform to NRCA Standards.
- F. Insulation and adhesives shall meet NFPA 90A requirements for flame spread and smoke generation.
- G. Cabinet insulation shall meet ASHRAE Standard 62P.

DELIVERY, STORAGE AND HANDLING

Unit shall be stored and handled per manufacturer's recommendations.

Part 2 — Products

EQUIPMENT

A. General:

Factory-assembled, single-piece, heat pump unit. Contained within the enclosure shall be all factory wiring, piping, controls, refrigerant charge (R-22), and special features required prior to field start-up.

B. Unit Cabinet:

- 1. Unit cabinet shall be constructed of phosphated, zinc-coated, pre-painted steel capable of withstanding 500 hours of salt spray.
- 2. Normal service shall be through a single removable cabinet panel.
- 3. The unit shall be constructed on a rust proof unit base that has an externally trapped, integrated sloped drain.
- 4. Indoor fan compartment top surface shall be insulated with a minimum 1/2-in. (12.7 mm) thick, flexible fiberglass insulation, coated on the air side and retained by adhesive and mechanical means. The indoor wall sections will be insulated with a minimum semi-rigid, foil-faced board capable of being wiped clean. Aluminum foil-faced fiberglass insulation shall be used in the entire indoor air cavity section.
- 5. Unit shall have a field-supplied condensate trap.
- 6. Metal Insulated Duct Covers for side discharge will be standard on all sizes.
- 7. Unit insulation conforms to ASHRAE 62P.

C. Fans:

- 1. The indoor fan shall be 5-speed, direct-drive, as shown on equipment drawings.

- 2. Fan wheel shall be made from steel and shall be double-inlet type with forward-curved blades with corrosion resistant finish. Fan wheel shall be dynamically balanced.
- 3. Outdoor fan shall be direct-drive, propeller-type with aluminum blades riveted to corrosion resistant steel spiders, be dynamically balanced, and discharge air vertically.

D. Compressor:

- 1. Fully hermetic compressors with factory-installed vibration isolation.
- 2. Scroll compressors shall be standard on all units.
- 3. Compressor Protection:
Defrost control shall protect compressor by preventing "short cycling."

E. Coils:

Indoor and outdoor coils shall have aluminum plate fins mechanically bonded to seamless copper tubes with all joints brazed. (Copper/copper and vinyl-coated construction available as option.) Tube sheet openings shall be belled to prevent tube wear.

F. Refrigerant Metering Device:

Refrigerant metering device shall be thermostatic expansion valve for cooling, and fixed orifice for heating.

G. Filters:

Filter section shall consist of field-installed, throwaway, 1-in. (25 mm) - thick fiberglass filters of commercially available sizes.

H. Controls and Safeties:

- 1. Unit controls shall be complete with a self-contained, low-voltage control circuit.
- 2. Units shall incorporate an internal compressor protector that provides reset capability.

I. Operating Characteristics:

- 1. Unit shall be capable of starting and running at 125°F (51.7°C) ambient outdoor temperature.
- 2. Compressor with standard controls shall be capable of operation down to 40°F (4.4°C) ambient outdoor temperature in cooling mode.
- 3. Unit shall be provided with 60-second fan time delay after the thermostat is satisfied.

J. Electrical Requirements:

All unit power wiring shall enter the unit cabinet at a single location.

K. Motors:

- 1. Compressor motors shall be of the refrigerant-cooled type with line-break thermal and current overload protection.
- 2. All fan motors shall have permanently lubricated bearings, and inherent, automatic reset, thermal overload protection.
- 3. Condenser fan motor shall be totally enclosed.
- 4. Evaporator Fan Motor to be high-efficiency brushless DC motor.
- 5. Condenser fan motor shall be totally enclosed.

GUIDE SPECIFICATIONS (CONT)

L. Special Features Available:

1. Coil Options:
Base unit with tin plated indoor coil hairpins.
2. Compressor Start Kit (single phase units only)
Shall provide additional starting torque for single-phase compressors.
3. Thermostat:
To provide for two-stage heating and one-stage cooling in addition manual or automatic changeover and indoor fan control.
4. Crankcase Heater:
Shall provide anti-floodback protection for lowload cooling applications.
5. Economizer:
 - a. Economizer controls capable of providing free cooling using outside air.
 - b. Equipped with low leakage dampers not to exceed 3% leakage, at 1.0 in. wc pressure differential.
 - c. Spring return motor shuts off outdoor damper on power failure.
6. Electric heaters:
 - a. Electric heater shall be available as a field installed option.
 - b. Heater elements shall be open wire type, adequately supported and insulated with ceramic bushings.
 - c. Electric heater packages must provide single point power connection capability.
7. Filter Rack Kit:
Shall provide filter mounting for downflow applications.
8. Flat Roof Curb:
Curbs shall have seal strip and a wood nailer for flashing and shall be installed per manufacturer's instructions.
9. Low Ambient Package:
Shall consist of a solid-state control and outdoor coil temperature sensor for controlling outdoor-fan motor operation, which shall allow unit to operate down to 0°F (-17.7°C) outdoor ambient temperature.
10. Louvered Grille:
Wire grille shall be standard on all units. Louvered grille shall be available as a field-installed option to provide hail guard and vandalism protection.
11. Manual Outdoor Air Damper:
Package shall consist of damper, birdscreen, and rainhood which can be preset to admit outdoor air for year-round ventilation.
12. Square-To-Round Duct Transitions (24-48 size):
Shall have the ability to convert the supply and return openings from rectangular to round.

