

LM Model

Water Source Heat Pump

2 to 6 ton

The new fully featured LM with two capacity scroll compressor and electronically commutated motor for best-in-class efficiency and comfort.

NEW	ASHRAE/AHRI/ISO 13256-1, English (I-P) Units Water Loop Heat Pump			
	LM MODEL	PART LOAD UP TO 22.5 EER	UP TO 6.5 COP	FULL LOAD UP TO 19.3 EER



Made in
the U.S.A.



Commercial Sales Catalog
fhp-mfg.com



BOSCH
Invented for life

Table of Contents

MODEL NOMENCLATURE.....	2	Horizontal Unit Installation	15
FHP MANUFACTURING	2	Ductwork and Sound Attenuation Considerations....	15
ADVANTAGES OF FHP’s TECHNOLOGY	2	Piping.....	16
LM MODEL 024 – 070	2	Condensate Drain Piping	16
STANDARD FEATURES.....	2	Thermostats	16-17
Cabinet	2	Hose Kits.....	17
Quiet Operation	3	Operating Limits – Cooling & Heating.....	17
Serviceability	3	UNIT SELECTION	18
Unit Configurations.....	3	PHYSICAL DATA	19
Filter Racks and Unit Options	3	HORIZONTAL CABINET CORNER WEIGHTS	20
Optional MERV 13 Filter	3	CERTIFIED PERFORMANCE DATA.....	20
FAN MOTOR OPTIONS.....	4	CAPACITY DATA	21
Constant Torque ECM.....	4	LM024 – Part Load.....	21
Constant Airflow ECM.....	4	LM024 – Full Load.....	22
Hanging Brackets	4	LM036 – Part Load	23
Water Connections.....	4	LM036 – Full Load	24
Two-Position Water Valve	4	LM048 – Part Load	25
Refrigerant Circuit	5	LM048 – Full Load	26
Evaporator Coil	5	LM060 – Part Load	27
Blower Housing.....	5	LM060 – Full Load	28
Unit Protection Module.....	6	LM070 – Part Load.....	29
UPM Control Board Features	6-7	LM070 – Full Load.....	30
UNIT OPTIONS	7	WATER PRESSURE DROP.....	31
Hot Gas Reheat	7	ANTIFREEZE CORRECTION DATA	31
Hot Gas Reheat Control Options	8	ELECTRICAL DATA	32
Special Considerations	8	Constant Torque and Constant CFM ECM	32
Low Temperature Well Water	8	Factory Installed Electric Heat Option	32
Indoor Pool Dehumidifying During Winter Months....	8	Units with EH option – Constant Torque ECM ...	33
Psychometric Chart	8	Units with EH option – Constant CFM ECM.....	33
DDC Controls	9	BLOWER PERFORMANCE	34
Combo Controls.....	9-10	ECM Constant Torque	34
ADDITIONAL FACTORY INSTALLED OPTIONS	10	ECM Constant CFM.....	35
SYSTEMS.....	11	VERTICAL UNIT DIMENSIONS.....	36
Water Source Cooling Tower/Boiler Systems.....	11	Vertical Top Discharge Water Source Heat Pump..	36
Geothermal Systems.....	11	LM024	37
Earth Coupling Options	11	LM036/048	38
Vertical Ground Loop System	12	LM060/070	39
Horizontal Ground Loop System	12	HORIZONTAL UNIT DIMENSIONS.....	40-42
Surface Water, Lake or Pond System	13	Horizontal Water Source Heat Pump.....	40-42
Well Water System	13	LM024 – Right Hand	43
TYPICAL HEAT PUMP OPERATING MODES	13	LM024 – Left Hand	44
Cooling Mode.....	13	LM036/048 – Right Hand.....	45
Heating Mode.....	13	LM036/048 – Left Hand.....	46
TYPICAL UNIT INSTALLATION	14	LM060/070 – Right Hand.....	47
Water-to-Air Heat Pump Cycle - Cooling.....	14	LM060/070 – Left Hand.....	48
Water-to-Air Heat Pump Cycle - Heating.....	14	SPECIFICATION GUIDE.....	49-52
Unit Location.....	14	NOTES	53-54
Vertical Unit Installation.....	14		

Model Nomenclature

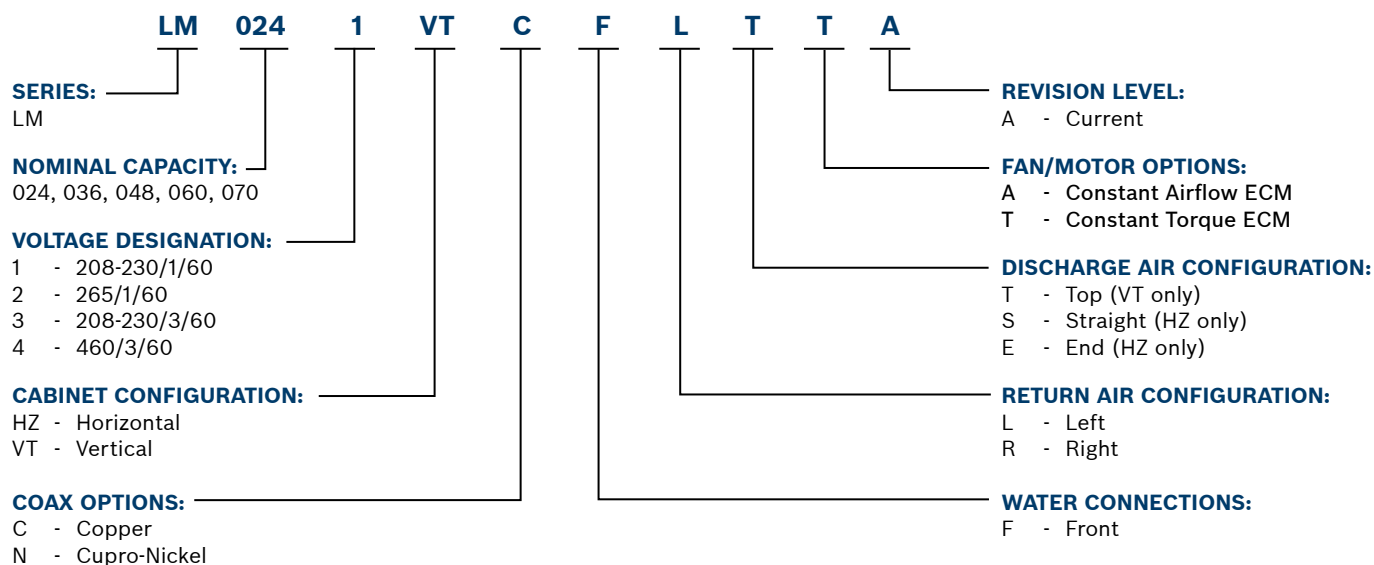

FHP Manufacturing

Specializing in efficient green technology for commercial heating and cooling products, FHP is one of the leading manufacturers of Geothermal and Water Source heat pumps, which assures that you are buying a unit you can trust. We are part of Bosch Thermotechnology Ltd., a Robert Bosch Group unit dedicated to providing highly efficient heating and cooling solutions to the private and public sector.

FHP headquarters has a state of the art facility with the latest manufacturing technology available. Each unit is factory tested according to Bosch quality standards in order to ensure our customers the highest level of satisfaction and comfort. We carefully select our suppliers in order to equip our products with the best components available.

Advantages of FHP Technology

- ▶ Best in class efficiency
- ▶ Best in class sound
- ▶ 2-stage capacity compressor
- ▶ Field configurable supply air
- ▶ Multiple humidity control options available
- ▶ Simple installation and operation



LM Model 024 - 070

- ▶ 5 Models 2 through 6 tons
- ▶ Horizontal, Vertical

The LM Series is a cost-effective two stage water source heat pump designed for commercial retrofit and new construction applications.

Standard Features

Cabinet

The LM unit cabinetry is constructed using heavy-gauge, G90 galvanized steel. This steel provides superior corrosion protection for units located indoors.

All interior surfaces are lined with 1/2" thick, 1.5 lb./cu. ft. density, Micromat insulation for thermal insulation and acoustical attenuation. This insulation is non-combustible, non-hydroscopic and does not support fungal growth. Insulation meets UL 181 erosion certification, NFPA 90A and 90B for fire protection and is certified to meet the GREENGUARD Indoor Air Quality Standard for Low Emitting Products.

Protection against corrosion is a feature in the LM series. A stainless steel drain pan will last the lifetime of the unit and resist corrosion and cracking that may occur with steel or plastic materials.

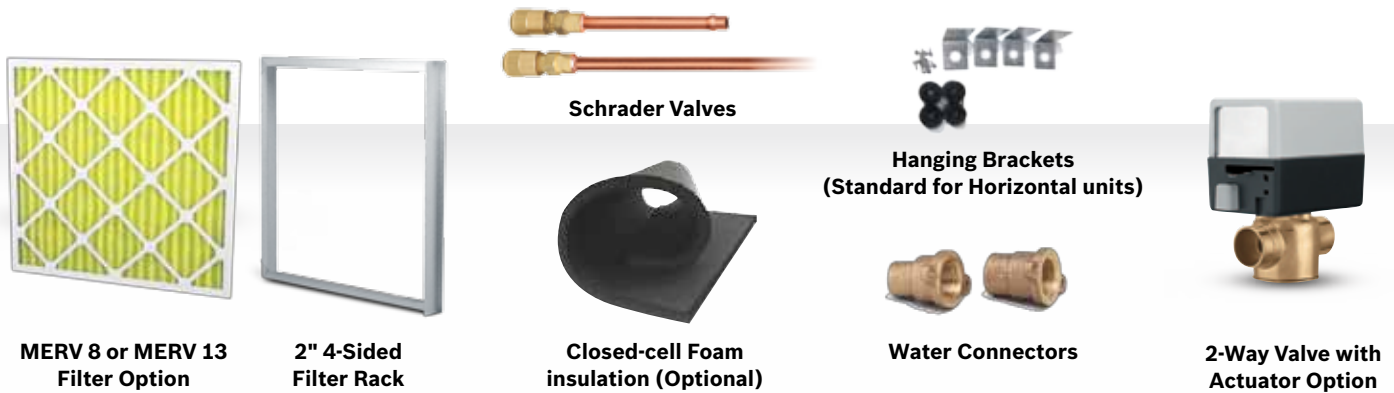

Standard Features

Quiet Operation

All panels are insulated with 1/2" thick, 1.5 lb./cu.ft. density micromat fiberglass insulation as standard for both thermal insulation and noise reduction.

Noise reduction is a critical consideration of the unit design. All LM units have a unique floating base. The Compressor is mounted on a heavy steel plate which rests on a high density rubber pad on the base of the unit. In addition, compressors are mounted on rubber grommets. This double isolation, unique to FHP, is standard in all LM series units preventing vibration and noise transmission from the compressor to the unit structure resulting in exceptionally quiet operation.

The LM offers an optional 1/2" thick, closed-cell foam insulation to help aid indoor air quality (IAQ) and to further attenuate low frequency noise from the compressor compartment. The closed-cell foam insulation option is available in all unit sizes.

For additional sound attenuation, an optional compressor blanket is available on unit sizes.



Standard



Optional

Serviceability

All units are designed to be serviced from the front of the unit. Schrader valves for high and low pressure gauges and the electrical box components are easily accessible for diagnosing and servicing the unit.

Insulated bulkheads in all units, separate the compressor section from the blower section, allowing the unit to be serviced during operation.

Large removable panels aid in servicing the unit, when necessary. Separate electrical knockouts in the unit corner post allow for easy and safe routing of high and low voltage lines to the inside of the cabinet.

Unit Configurations

All units are available in horizontal and vertical configurations. Additionally, several options of return air and supply air are offered as standard, providing configuration flexibility.

Filter Racks and Unit Options

Units come standard with a 1" MERV 5 construction filter. A 2" four-sided filter rack and pleated filter is optional and greatly improves air filtration. Filter doors allow for easy routine maintenance and changing of the air filter. A 1" return duct collar is integral to the filter rack eliminating the need for field mounted duct collars.

Optional MERV 13 Filter

The optional MERV 13 filter is the optimal choice for premium air filtration on commercial HVAC projects. The MERV 13 filter is a cost effective way of upgrading

air quality while maintaining low pressure drop and sustaining long service life. This filter effectively removes 96% of airborne matter, such as fine particulates, bacteria, smoke, gases and odors, and allergens including dust mites, pollen, mold spores, dust and smog. ECM motors can handle higher external pressure drops and are required when using high efficiency MERV 13 filters.

Fan Motor Options

Constant Torque ECM (Standard)

The LM's constant-torque blower motor option offers improved efficiency (up to 33%) over the standard PSC motor. This Constant Torque Motor is similar in function to a PSC, but can handle up to 1 in.w.g. external static pressure making it a wise choice for high filtration applications. The 460 Volt constant torque motors do not require a neutral wire.



**Constant Airflow
ECM Option**



**Constant Torque
ECM Option**

Constant Airflow ECM

The LM's new high efficiency Constant Airflow ECM option, available in 1/3hp to 1hp, provides constant airflow in a wide static pressure range up to 1 in.w.g. These motors are a great choice in high filtration applications, such as MERV 13. The Constant Airflow ECM motor has a soft start/stop feature, keeping noise to a minimum.

Passive Dehumidification can be achieved with the Constant Airflow ECM by reducing nominal airflow by 15%. This control feature lowers air coil temperature and prevents over-cooling of the space when in dehumidification mode. The 460 V constant airflow ECM requires a neutral wire.

Hanging Brackets

All horizontal units come standard with hanging bracket kits for suspending the unit from field supplied hanger rods. These kits include heavy duty steel brackets and rubber grommets for sound and vibration isolation from the building structure.

Water Connections

All water connections are heavy duty bronze FPT fittings securely fastened to the unit corner post. This allows connecting to a flexible hose kit without the use of a backup wrench making for easier, faster installation.

Two-Position Water Valve (internal)

The two-position motorized water valve is optional on all unit sizes and is a great energy savings option. The valve opens to allow 100% fluid flow through the coaxial heat exchanger only when there is a call for cooling or heating. Closing off fluid flow to the unit when there is no call for cooling or heating reduces system operating costs, when using variable speed pumping, by reducing the speed of the primary loop pumps.

Internal Pump

The internal pump cannot be used in conjunction with the two position water valve. The internal pump option is an internally mounted on/off circulating pump.

Smart Start

The SmartStart control assists the unit's start up and improves start up efficiency as much as 65%. with ease of compressor start up. SmartStart is for single phase scroll compressors.

- ▶ Reduce wear and tear on compressor during start up
- ▶ Integrated current limit
- ▶ Rated operational voltage: 230 VACrms, 50/60 Hz
- ▶ Rated operational current: up to 32A: AC-53b
- ▶ Integral bypassing of semiconductors
- ▶ Built-in transient over-voltage protection
- ▶ Under-voltage protection after ramp up
- ▶ Factory installed or field installed accessory
- ▶ EMC Compliant
- ▶ Optional auxiliary alarm relay output
- ▶ Relay Protection
- ▶ UL, cUL listed
- ▶ Optimized algorithm for high pressure starts
- ▶ Integrated protection against short-cycling.



Coax Coil



Two Capacity Scroll Compressor



Duo Guard – Tin Plated with Coated Fin Evaporator Coil (Optional)

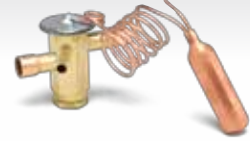

TXV Valve (Standard)

Refrigerant Circuit

LM Series units are designed using the optimum combination of compressor, water and air coils to provide peak performance.

LM Series units are rated to withstand 600 PSIG working refrigerant pressure and 400 PSIG working water pressure.

Heavy duty heat pump compressors are used in all units. These high efficient two capacity compressors unload when the demand is low in heating or cooling; matching your capacity requirements at the highest efficiency level possible. At the same time delivering the best comfort possible for both latent and sensible requirements. When demand is high the compressor switches to full capacity matching the load demand for heating or cooling.

Refrigerant to water heat exchangers are coaxial tube-in-tube type providing a robust construction, ensuring years of trouble free operation. Coaxial coils are selected and designed for peak performance, offering the best combination of low water pressure drop and maximum heat transfer in both the cooling and heating modes. Standard coaxial coils have a copper interior water tube and a steel outer shell. Optional Cupro-Nickel coils are available for applications where the water is of lower quality.

In geothermal applications where fluid temperatures can drop below the dew point of the surrounding air, optional insulation is available to prevent water coils and refrigerant piping from sweating.

A pilot operated four-way reversing valve in the refrigeration circuit allows the unit to operate in either the heating or cooling mode. All FHP units have the reversing valve energized in cooling mode. This will ensure you are not left without heat in the middle of winter, should the reversing valve coil fail.

Evaporator Coil

LM comes standard with a copper coil aluminum fin evaporator coil. These evaporator coils employ lanced fin and rifled tubing for maximum heat transfer. Large face areas result in lower face velocity reducing sound while ensuring high latent heat removal for maximum dehumidification in the cooling mode.

Available as an option is the Duo-Guard evaporator coil protection. Duo-Guard Protection® - Tin Electro-Plated Copper Tubing with High-Tech Polymer Coated Aluminum Fins will protect the evaporator coil from all forms of corrosive elements in the airstream.

Refrigerant flow to the air coil is metered by a Bi-Flow Balance Port Thermostatic Expansion Valve (TXV) as standard in LM units. TXV's provide unit optimization and a more stable control over a wider range of operating conditions. This is especially important with two capacity scroll compressor technologies.

Blower Housing

A removable inlet ring is a standard feature of the blower housing on all unit sizes. The removable inlet ring helps facilitate motor removal without having to remove the fan housing from the cabinet.



**Blower Housing
(with Removable Inlet Ring
for Serviceability)**



UPM Control Board

Unit Protection Module

Each LM unit is factory provided with a Unit Protection Module (UPM) that controls the unit operation and monitors the safety controls that protect the unit. Powered by a standard 75 VA transformer, the UPM interfaces with the thermostat or direct digital controller. The main purpose of the UPM is to protect the compressors by monitoring the different states of switches and sensors. This module provides time delays and protects the unit against freezing of the water to refrigerant and air to refrigerant heat exchangers as well as condensate overflow when the appropriate sensors are installed.

Standard safety controls include the following:

- ▶ High pressure switch located in the refrigerant discharge line.
- ▶ Low pressure switch located in the unit refrigerant suction line.
- ▶ Standard low fluid temperature (freeze) protection sensor. The freeze protection sensor, located on the refrigerant liquid line entering the coaxial heat exchanger is designed to disable compressor operation when the unit is in the heating mode, should the refrigerant temperature fall below either 30°F (-1.1°C) or 15°F (-9.4°C).
- ▶ Condensate overflow protection sensor is standard and factory mounted in the drain pan of the unit.
- ▶ Low air coil temperature (freeze) protection sensor disables the compressor when the refrigerant entering the air coil drops below 30°F (-1.1°C).

UPM Control Board Features

- ▶ **Anti-Short Cycle Timer**—5 minute delay on break timer to prevent compressor short cycling.
- ▶ **Random Start**—Each controller has a unique random start delay ranging from 270 to 300 seconds after power is applied to the board. This will prevent the simultaneous start of multiple units after a power outage.
- ▶ **Low Pressure Bypass Timer**—The low pressure switch is bypassed for 120 seconds after a call for compressor operation to prevent nuisance low pressure lockouts during cold start-up in the heating mode.
- ▶ **Brownout/Surge/Power Interruption Protection**—Prevents compressor operation should the voltage drop below 10% of unit rated value. The unit will restart once the voltage is within tolerance and the random start has timed out.
- ▶ **Malfunction (Alarm) Output**—The controller has a set of contacts for remote fault indication. This can be either a steady output or can be set to pulse with the fault code. Two connections are available - one to provide a 24 volt output, the other to provide a dry contact.
- ▶ **Test Service Mode**—A dip switch setting is provided to reduce all time delay settings to 10 seconds maximum during troubleshooting for verification of unit operation.
- ▶ **L.E.D. Fault Indication**—Two L.E.D. indicators are provided as follows:
 - ▶ **Green:** Power L.E.D. indicates 18 – 30 VAC present at the board.

► **Red:** Fault indicator with blink codes identifying the particular fault. This information is available via the malfunction (alarm) output contacts.

1 Blink - High Pressure

2 Blinks - Low Pressure

3 Blinks - Low Fluid Temperature (Freeze Protection)

4 Blinks - Condensate Overflow

5 Blinks - Brownout condition

► **Intelligent Reset**—If a fault condition is initiated, the 5 minute delay on break time period is initiated and the unit will restart after this delay expires. The UPM is configurable for either 2 or 4 fault occurrences before going into a hard lockout. The selection is made through a dip switch setting on the board. If the fault condition still exists or reoccurs twice or four times within one hour, the unit will go into a hard lockout and requires a manual lockout reset. A condensate overflow fault will, however, put the unit into a hard lockout immediately.

► **Lockout Reset**—A hard lockout can be reset by turning the unit thermostat off and then back on or by shutting off unit power at the circuit breaker. The method of reset is selectable by the dip switch on the board.

Additional Unit Options

Hot Gas Reheat

Hot gas reheat (HGR) allows the user to not only control space temperature, but also humidity levels within the conditioned space. Excessive moisture in the space can promote mold growth leading to damage in the structure or interior surfaces, as well as reducing the air quality and creating an unhealthy environment.

Possible causes of excess humidity could be a byproduct of the unit having to operate under a widely varying load, an oversized short cycling unit, a high percentage of unconditioned outside air being introduced into the space, a high latent load in the space or any location where humidity infiltration is a problem.

Typical unit control is by a wall mounted thermostat that senses temperature in the occupied space. By utilizing a humidistat in addition to the thermostat, LM units with Hot Gas Reheat are able to control the humidity levels in the space as well. The Hot Gas Reheat option allows cooling and dehumidification to satisfy both the thermostat and humidistat while preventing over-cooling of the space while in the dehumidification mode.

Once the thermostat reaches set point temperature, and is above humidity set point, the unit controller will energize the reheat valve operating the unit in hot gas reheat mode, first cooling and dehumidifying, then reheating the air (using hot refrigerant gas) before delivering it to the space, usually 2° to 5°F below room temperature. The unit operates like a dehumidifier by reheating the air along a constant sensible heat line, while the relative humidity of the leaving air is reduced. This option offers significant energy savings over reheating air with electric heating coils.

The moisture removal capacity of a specific heat pump is determined by the unit latent capacity rating. A heat pump's latent capacity can be determined by reviewing the heat pump specification data sheets. Depending upon the entering water and air conditions, a total and sensible capacity can be interpolated from the data sheets. Subtracting sensible capacity from total capacity yields latent capacity. Dividing the latent capacity by 1069 converts the amount of moisture removal from BTU/Hr. to Pounds Per/Hr.

A hot gas reheat valve and a reheat coil are included in the refrigerant circuit. The refrigerant circuit in the cooling and heating modes are identical to a standard heat pump.

In the reheat mode, the compressor discharge gas is diverted through the reheat valve to the reheat coil which is located downstream of the cooling coil. The superheated refrigerant gas reheats the air leaving the cooling coil. The hot refrigerant gas then passes through the water to refrigerant coil where it is condensed to a liquid. From this point

the rest of the cooling cycle is completed as in a regular heat pump. There are check valves to prevent refrigerant flow into the reheat coil during standard cooling/heating cycles.

Hot Gas Reheat Control Options

There are several ways to control heat pumps with hot gas reheat. You should choose the means that best suits your specific application. Please refer to the Hot Gas Reheat wiring diagrams for typical thermostat wiring. Most heat pump compatible thermostats in conjunction with a humidistat are acceptable for use, (Note: “O” output for reversing valve energized in cooling mode is required.) Combination thermostat/humidistats are also available.

Special Considerations

Some applications require special attention to maximize the performance of the hot gas reheat function:

- ▶ Low Temperature Well Water
- ▶ Indoor Pool Dehumidifying During Winter Months (Re: Heating Mode)

Consult the factory for special application considerations.

Low Temperature Well Water

When low temperature well water is utilized as the water source (below 55°F), a means of establishing two flow rates, one for the cooling/reheat mode and one for heating mode is recommended. In the cooling mode at low entering water temperatures and standard flow rates, discharge pressures and corresponding discharge gas temperatures are relatively low. At these conditions, when the reheat mode is initiated, the low temperature discharge gas can reduce reheat capacity. A means to reduce the water flow rate and elevate the discharge pressure/temperature in cooling/reheat mode should be provided. Conversely, at low entering water temperatures in the heating mode, system suction pressure is reduced causing a loss in heating capacity. A means of providing higher flow in the heating mode should be supplied. The simplest way to accomplish the above is to install water regulating valves.

Indoor Pool Dehumidifying During Winter Months

It is important to remember that when in the reheat/dehumidification mode the heat pump is cooling and reheating. A secondary means of heating the space during the dehumidification mode should be provided. For indoor pool environments, the indoor space temperature should be kept at least two (2) degrees F above the pool water temperature. If this is not done the warm pool water attempts to heat the space and the humidity levels increase exponentially. The heat pump is normally sized to handle the design latent load moisture removal. A second heat pump or resistance heat should be provided to handle the structure’s shell loss load. Duo-Guard Evaporator Coil Option is required for this type of application.



Protective coatings are highly recommended for all pool applications, due to the highly corrosive chemical environment.

Psychrometric Chart

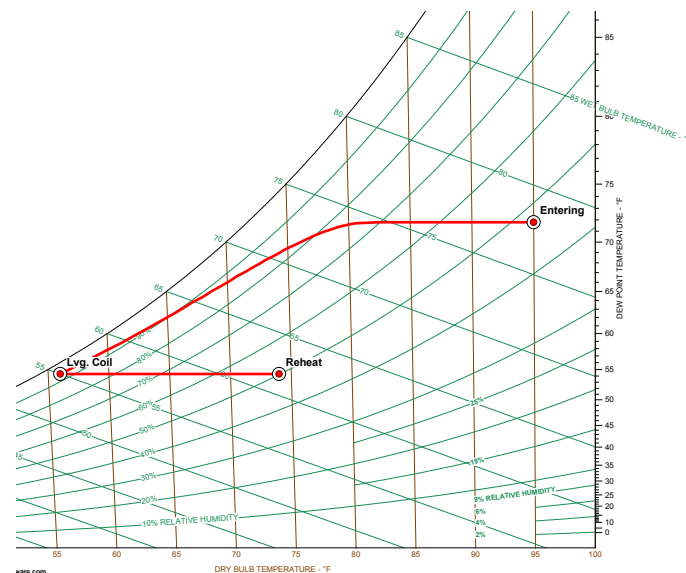

Figure 1



DDC Control Board

DDC Controls (Option)

The optional FHP factory mounted DDC Controller is preprogrammed and installed in the unit with the Unit Protection Module (UPM) to be job site ready. The unit will operate in a 100% stand-alone control mode or connect to a Building Automation System (BAS) using open protocols BACnet, Modbus, N2 or LonWorks (with an optional Lon card). Stand-alone DDC modules must use remote intelligent sensors and are to be programmed by the FHP BACView controller only.

Zone temperatures, leaving air temperatures and water temperatures can be monitored from the central control computer and unit fault indication displayed.

Available inputs/outputs include:

- ▶ Discharge air temperature
- ▶ Leaving water temperature
- ▶ Fan run time
- ▶ Override time remaining
- ▶ Night setback status
- ▶ Percent of units cooling
- ▶ Percent of units heating
- ▶ Cooling set point
- ▶ Heating set point
- ▶ Status of all the alarms

- ▶ Space temperature
- ▶ Occupied heating and cooling set points
- ▶ Continuous or cycle fan during occupied mode
- ▶ Command for occupied or unoccupied mode
- ▶ Command for override of the unoccupied mode (unit resorts to occupied set points)
- ▶ Set point adjustment

To complement the controller, FHP offers a line of intelligent space sensors, which provide precision measurement and communication capabilities in an attractive low profile enclosure. A hidden communications jack provides access to the HVAC control system for commissioning and maintenance.

Models available include:

- ▶ The RS Standard which has no local temperature set point adjustment.
- ▶ The RS Plus offers a local set point adjustment and override to an occupied mode and LED indication of current status.
- ▶ The RS Pro has a large LCD display and easy-to-use occupant controls for set point adjustment.

A BACView hand held diagnostic tool is available to allow local access to display and modify user defined properties without any computer software.



**Combo Base
DDC Control**



**Plus DDC
Control/Sensor**



**Combo Pro DDC
Control/Sensor**

Combo Controls

The Combo Pro DDC control/sensor has a LCD screen that can display the current temperature and set temperature. It can also display relative humidity and CO₂ settings as well as their current readings. It comes with a button for additional information that can be displayed.

You can order it as:

- ▶ Temperature setting only
- ▶ Temperature with relative humidity settings
- ▶ Temperature, relative humidity, and CO₂ settings

The Plus DDC control/sensor has a little different look to it. It has a occupied indicator that identifies the control to be operating in occupied conditions. It comes with a slide bar of for some manual temperature control in the occupied mode +/- setting can be adjusted during commissioning.

The Combo Base DDC control is a read only sensor and has no adjustments to any set point.

It can be ordered as:

- ▶ Temperature sensor
- ▶ Temperature and relative humidity sensor

Additional Factory Installed Options

- ▶ 5, 10, 15, 20 Kw Electric Heaters
- ▶ Differential Pressure Switch
- ▶ Energy Management Switch (on / off)
- ▶ Blower Motor Current Sensor
- ▶ Compressor Monitor Relay
- ▶ Freeze Sensor Antifreeze Setting
- ▶ Pump Relay
- ▶ Phase Monitor
- ▶ Flow Proving Switch
- ▶ 40 Amp Disconnect Switch (1 or 3 phase)
- ▶ Comfort Alert Module
- ▶ Start Assist Kit
- ▶ Two Way Solenoid Valve
- ▶ Circulating Pump
- ▶ Wire for 208 Volt

Systems

LM Series may be used in a variety of different applications depending on the system design. An overview of tower/boiler and geothermal systems is given below. There could be several variations and combinations of these systems.

Cooling Tower/Boiler Systems



Water source heat pumps with cooling tower/boiler systems have been used for many years and are recognized as having a low installation cost and providing more energy efficient operation than most other systems on the market.

In a typical building, each office or space would receive its own heat pump. This ensures that the unit will independently satisfy the heating or cooling requirements for that space irrespective of the requirements of any other space. Unlike some other systems, this offers individual control and enhanced comfort in all areas.

All the units are connected to a common water loop containing, in addition to the heat pumps, a cooling tower, boiler, a primary and standby pump and a loop water temperature controller. In the summer cooling mode, the units are cooling and rejecting heat to the water loop. This heat is then rejected to the atmosphere through a cooling tower. In winter, heat is taken from the loop and, together with the compressor's heat of compression, used to heat the space. The heat removed from the loop is then replenished by the boiler. The loop water tempera-

ture controller will keep the fluid within certain temperature limits typically 70°F in winter and 85°F in summer by cycling either the cooling tower or boiler operation.

In today's modern buildings the interior core usually has a net cooling requirement year round irrespective of the outside temperature. This is due to the internal heat gains from people, office equipment and lighting. The heat from heat pumps operating in cooling is rejected to the common water loop and is absorbed by heat pumps on the building's perimeter that are in the heating mode. In effect the system is transferring energy around the building areas from where it is in excess to those areas where it is needed. In many instances we find a balanced system where the heat generated in the interior space is sufficient to heat the perimeter, resulting in neither the cooling tower nor boiler operating. This concept, unique to a water source system, provides the most energy efficient system on the market.

Geothermal Systems

The earth has a tremendous capacity of storing thermal energy, which can be utilized to heat or cool a building.

A geothermal system offers all the benefits of a cooling tower and boiler system with the additional advantage of having overall greater energy efficiency. As the cost of energy increases, geothermal installations are becoming the system of choice by developers and design engineers.

There are several alternative methods of utilizing the energy contained in a geothermal system, giving the design engineer several options for selecting the one that is right for a particular application.

Earth Coupling Options

Ground Loop Systems (Closed Loop)

Lengths of high density polyethylene piping are buried in the earth either in vertical bore holes or horizontal trenches depending on the space available.

Fluid from the loop inside the building circulates through these pipes either rejecting heat to the ground when there is a net cooling requirement or absorbing heat from the ground when heating is the dominant requirement.

The temperature of the earth below 6 feet is relatively constant and is not affected by the ambient temperature. For this reason, the ground temperature is cooler than the summer ambient and warmer than the winter ambient in most regions. Geothermal systems are able to operate effectively in extreme ambient conditions exceeding 100°F in summer and -30°F in winter. This is one of the reasons why geothermal systems have such an advantage over other systems. An additional advantage is that no fossil fuels are used, reducing the carbon emission of the building.

Even in areas which are cooling or heating dominant a hybrid system can be used with a downsized cooling tower or boiler. This system will reduce the installed cost significantly with only a modest impact on overall operating efficiency.

Geothermal systems may cost more to install but the savings in energy and low maintenance costs more than off set this with payback times typically five years or even less.

Vertical Ground Loop System



This method is used mainly in commercial buildings or where space for a loop field is limited. Vertical holes 100 to 400 feet deep are drilled in the ground, and a single loop of high density polyethylene pipe with a U-tube at the bottom is installed. The bore hole is then sealed with grout to ensure good contact for heat transfer with the soil. The size of the project will determine how many bore holes are required. The vertical ground loops are then connected to a horizontal header pipe that carries fluid to the building and circulated to each heat pump. The Earth's temperature is stable below the surface which is an advantage for this system and provides for the greater efficiency. Vertical ground loop fields may be located under buildings or parking lots. The life expectancy is in excess of 50 years.

Horizontal Ground Loop System



This type is cost effective on smaller projects or where there is sufficient space for the loop field. Trenches, three to six feet deep are dug in which a series of high density polyethylene pipes are laid. These loops are manifolded and connected to the loop inside the building which feeds the heat pumps. The fluid is then circulated, absorbing or rejecting heat to the earth depending on the requirement for heating or cooling.

Typical Heat Pump System

Surface Water, Lake or Pond System



This type of design is economical when a project is located near a body of water. Fluid circulates through polyethylene piping in a closed system, just as it does through ground loops, but in this case, underwater. The pipes may be coiled in a slinky to fit more surface into a given amount of space. The lake needs to be a minimum size and depth depending on the building load. Lake loops have no adverse impact on the aquatic system. Specialized lake heat exchangers are also available for this application. New technology is emerging for stainless steel and titanium heat exchangers.

Well Water System



This type of installation is only possible if there is sufficient ground water available in a well. The water must be of good quality. Local codes may limit the use of this system in certain areas. The arrangement is referred to as an open system which means that water

is pumped directly from the source into the geothermal unit and then discharged either into a return well or a body of water. The water quality is unaffected other than a change in the temperature. Refer to the installation manuals for water quality guidelines.

Typical Heat Pump Operation

Cooling Mode

In the cooling mode, hot high pressure refrigerant gas is pumped from the compressor to the water-to-refrigerant heat exchanger via the reversing valve.

Water, or an anti-freeze solution, flowing through the water-to-refrigerant heat exchanger transfers heat from the refrigerant to the fluid raising the fluid temperature while condensing the hot gas into a liquid. This liquid refrigerant then flows through a metering device, where the refrigerant is expanded to a cold liquid, to the air-to-refrigerant heat exchanger coil.

The air-to-refrigerant heat exchanger cools and dehumidifies air by evaporating the liquid refrigerant. The cooling cycle is completed when the refrigerant flows as a low pressure gas through the reversing valve and back to the suction side of the compressor.

Cool dehumidified air is circulated to the space maintaining comfort conditions.

Heating Mode

During the heating mode, the high pressure refrigerant gas is pumped from the compressor to the air-to-refrigerant heat exchanger coil via the reversing valve.

In the air-to-refrigerant heat exchanger coil, the heat is removed by the air that passes over the coil surface, and the hot gas condenses into a liquid.

The heated air is ducted to the space and provides heating for the building.

The refrigerant liquid then flows through a metering device to the water-to-refrigerant heat exchanger.

Typical Unit Installation

Water-to-Air Heat Pump Cycle – Cooling

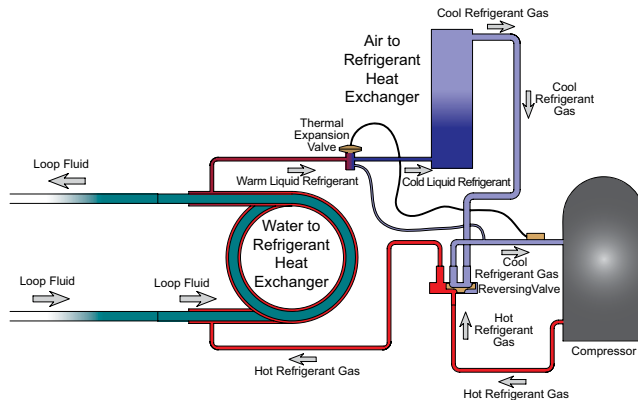

Water-to-Air Heat Pump Cycle – Heating

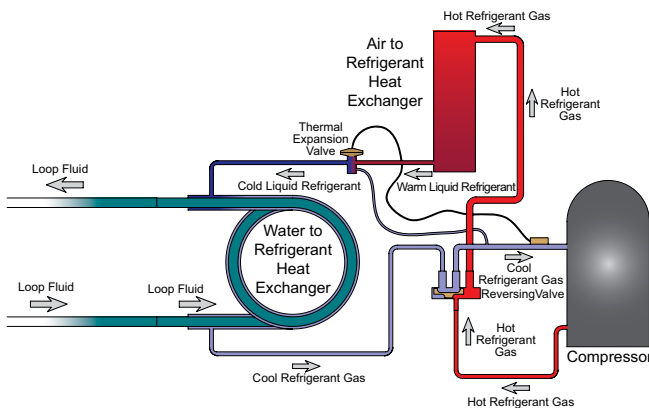

Water, or an anti-freeze solution, circulates through this heat exchanger and is cooled by the evaporating refrigerant which evaporates into a gas. The heating cycle is completed when the refrigerant flows as a low pressure gas through the reversing valve and back to the suction side of the compressor.

Unit Location

Any mechanical device will, at some point in time require servicing and repair.

With this in mind sufficient space must be provided around the unit for service personnel to perform maintenance or repair.

Units are not designed for outdoor installation. Avoid locations where the unit may be exposed to freezing conditions or where the humidity levels could cause condensation on the unit panels, for example, when exposed to outdoor ambient conditions.

Vertical Unit Installation

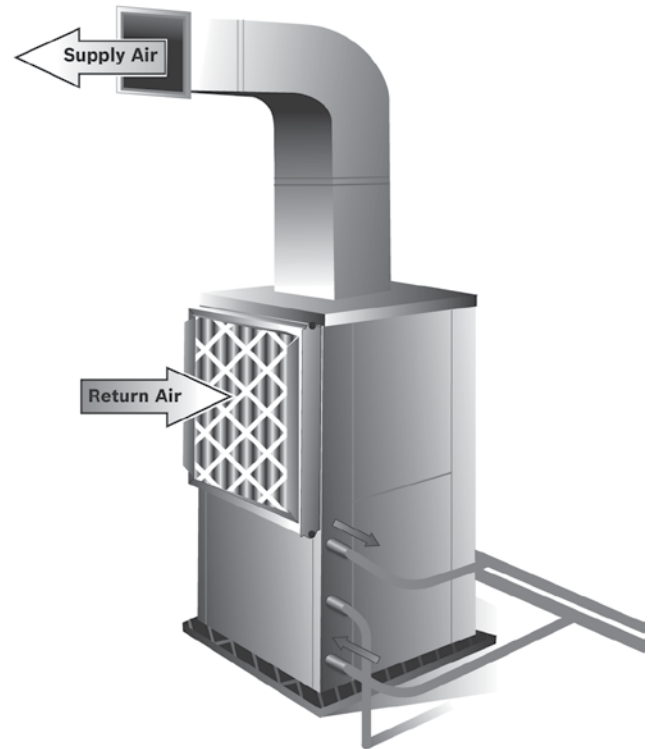

Figure 3

Vertical units are normally installed in a closet or mechanical plant room.

If installed in a closet or other confined space, ensure adequate space for return air to the unit.

Sufficient space must be provided for filter replacement and access to the compressor and blower for service.

Units should be set on a piece of rubber, neoprene or other vibration absorbing material at least 1/3" to 1/2" thick. The pad should extend 3/4" over the entire base of the unit.

Avoid direct line of sight to the unit. Install a sound baffle over any door that has a return air grille.

Typical Unit Installation

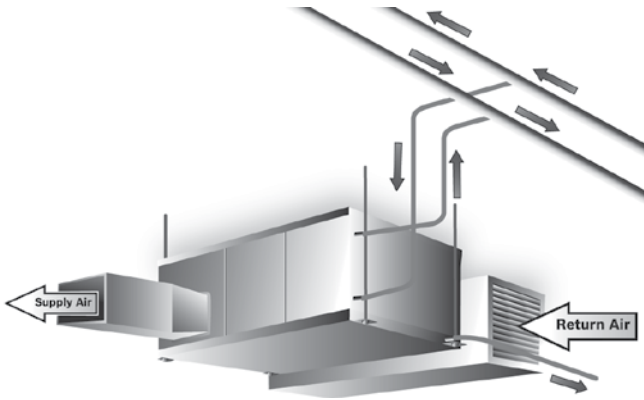

Horizontal Unit Installation

Horizontal units are typically suspended above the ceiling by four (field supplied) 3/8" threaded rods fastened to the unit by the factory supplied hanger bracket kits. The kits include rubber isolators to help prevent transmission of vibration and noise to the building structure. Units should be located directly below a structural member, so that it is securely anchored.

A horizontal unit should be positioned to allow for removal of the filters and access panels. Allow at least 18" clearance on each side of the unit for service and 36" in front of the unit for maintenance access. The filter needs to be slid out and sufficient space must be provided to allow this.

Do not install the unit above any piping or electrical raceways. The unit should be able to be removed to the floor without major rearrangement of other mechanical or ceiling components.

Consideration needs to be made as to the location of the units. Avoid installing units directly above occupied spaces (e.g. above office desks or classrooms). This will minimize possible disruption to the occupants if maintenance or service is required as well as keeping a potential source of noise out of the area. If possible, units should be installed above the hallway drop ceiling in schools, and the supply and return air is routed directly into classrooms. Local code may require fire dampers to be used in this application.

Ductwork and Sound Attenuation Considerations

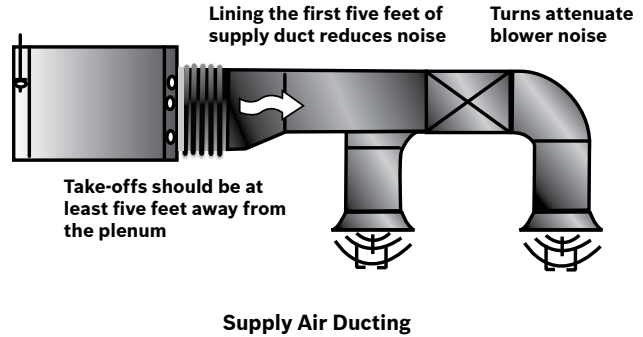

Sound is becoming an increasingly important factor in all HVAC installations. The LM Model has been designed to minimize sound, but sound acoustical design plays an important part of the sound level in the space.

Most of the problems associated with HVAC generated sound can be avoided by paying close attention to duct design and equipment placement.

A discharge flange is provided on all horizontal unit models for fastening of ductwork. We recommend using a flexible collar between the discharge flange and the duct transformation to reduce vibration transmission from the cabinet and to simplify disconnection of the unit from the ceiling ductwork.

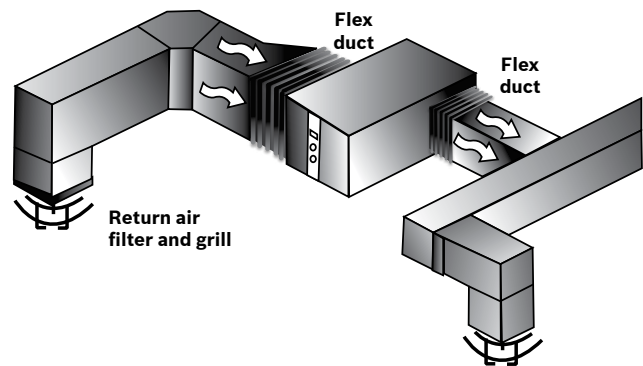

Return air to the unit could be either free return or ducted. The filter rack is provided with a 1" flange should a ducted return be used. We recommend using a flexible collar between the return flange and the duct transformation to reduce vibration transmission

from the cabinet and to simplify disconnection of the unit from the ductwork.

Sound is transmitted down the ductwork and it is important to avoid direct line of sight between the unit and the space, both on the return or supply side. To accomplish this, design the duct runs with two 90° turns.

As a general recommendation, duct interiors should have an acoustic / thermal lining of least 1/2" thick over the entire duct run or a minimum of the first 5 feet of the supply trunk.

Line the last five diameters of duct before each outlet with a one-inch thick sound blanket. Line elbows and transition pieces, as well as a short distance upstream and downstream of the fittings.

Elbows, tees and dampers can create turbulence or distortion in the airflow. Using aerodynamic fittings will help in reducing this effect. Place a straight length of duct, 5 to 10 times the duct width, before the next fitting to smooth out airflow.

Diffusers that are located in the bottom of a trunk duct can also produce noise.

Balancing dampers should be located several duct widths upstream from an air outlet.

Ductwork should be mounted and supported using isolation devices that absorb vibration.

Applications such as Hotel, Motel, Dormitory or Nursing Home that use a single duct discharge are susceptible to noise. These applications typically have low static pressures and short duct lengths. In these applications the discharge duct must be fully lined and have a square elbow without turning vanes. A velocity not exceeding 500 to 600 fpm is recommended. Return air for these applications should enter through a sidewall grille and route up the stud space to a ceiling plenum.

For horizontal heat pumps mounted in the ceiling plenum, an insulated return plenum is sometimes placed at the return air opening to further attenuate line-of-sight sound transmission through return openings.

Piping

The water loop system is typically designed using a "reverse return" piping system which includes a flow control device so that flow requirements are met for each zone.

A high pressure stainless steel flexible hose kit is recommended to connect the unit to the building's hard piping and acts as a sound attenuator for both the unit operating noise and hydraulic pumping noise. One end of the hose has a swivel fitting to facilitate removal of the unit for replacement or service.

Hose kits come in several configurations, but in all cases should include supply and return shutoff ball valves to allow removal of a unit without the need to shut down the entire heat pump system. The hose kit may contain either a manual or automatic flow control that may be preset to ensure correct water flow to the unit.

Pressure / Temperature ports should be included in these fittings to allow the service technician to measure water flow and temperatures when checking unit operation.

Condensate Drain Piping

Condensate piping can be made of steel, copper or PVC pipe. In most cases, PVC pipe eliminates the need to wrap insulation around the pipe to prevent sweating.

A 3/4" FPT condensate drain connection is installed in the unit. The condensate piping must be trapped at the unit and pitched away from the unit not less than 1/4" per foot. A vent is required after the trap so that the condensate will drain away from the unit. The vent can also act as a cleanout if the trap becomes clogged. The condensate drain should not be directly piped to a drain/waste/vent stack. See local codes for the correct application of condensate piping to drains.

Thermostats

The unit control may be as simple as a single stage thermostat or the unit may have a DDC controller integrated into the building management system.



Multiple Stage Thermostats

All external low voltage control wiring is made to the thermostat terminal located in the unit electrical box.

Thermostats may be manual change over, auto change over, programmable or non-programmable depending on the requirements of the project. A full line of thermostats are available from FHP as an accessory.

Hose Kits

Hose kits are recommended between the unit and system loop piping. This will help eliminate the transmission of vibration and noise from the unit to the space.

Hoses are fire rated fiber reinforced EPDM Stainless Steel braid hoses with swivel connections.

Maximum working pressure 400 PSI for sizes 1/2" – 1" and 300 PSI for sizes 1 1/4" – 2".

A variety of hose kits are available depending on the job requirement.

- ▶ **Kit 1** – Hose kit only either 24" or 36" long.
- ▶ **Kit 2** – Hose kit with ball valves on the supply and return hoses. Valves have P/T (pressure/temperature) ports to facilitate pressure and temperature readings.
- ▶ **Kit 3** – Hose kit with automatic flow control valve. The design flow rate is preset at the factory per the design conditions and will automatically limit the flow to this value. This will greatly facilitate balancing of the fluid loop and ensuring each unit gets the required flow.



Hose Kit

- ▶ **Kit 4** – Hose kit with a Y-strainer and blow down valve on the supply side. The filter screen is 20 mesh, 304 stainless steel to help prevent dirt and debris from entering the water coil.
- ▶ **Kit 5** – Hose kit with 24 v 2 position solenoid valve. This could be used to shut off flow to the unit when there is not a call for heating or cooling. A typical application would be with VFD pumping.
- ▶ **Kit 6** – Hose kit with 23 v 2 position solenoid valve. Hose kit options are available in the accessories section of the BST selection software.

Operating Limits

LM Series are capable of operating over a wide range of conditions. For operation in a geothermal application or any other installation where the loop fluid temperature may drop below the ambient dew point, the extended range option is recommended. This consists of additional insulation on the piping to prevent condensation.

- ▶ Maximum and minimum fluid conditions are at unit rated flow rate.
- ▶ Maximum and minimum operating limits may not be combined. If one value is at either maximum or minimum, the other two should be at normal operating range.
- ▶ Entering fluid temperatures below 45°F in the heating mode require antifreeze.

Unit Selection

To ensure that you get the optimal performance from your FHP heat pump, it is important that they be selected accurately to match your design conditions.

Prior to making equipment selections the zone conditions need to be determined. FHP Manufacturing recommends using a building load program to determine the heating and cooling loads.

The catalog provides a wide range of entering air and water conditions that will meet most applications. The unit performance can be determined by referring to the data tables beginning on page 20 to page 35.

Our Bosch Select Tools Selection Software (BST) is designed to provide you with a fast and accurate selection based on your specific conditions. This software is available through the commercial website. You may click on the BST link and request an account. www.fhp-mfg.com

The following is a typical example for a unit selection. Design conditions are given as follows:

Total Cooling Load	= 37.8 MBTUH
Sensible Cooling Load	= 29.5 MBTUH
Total Heating Load	= 41.4 MBTUH
Air Flow Required	= 1140 CFM
Entering Air Temp Cooling (db/wb)	= 75°F / 63°F
Entering Air Temp Heating	= 60°F
Entering Water Temp Cooling	= 80°F
Entering Water Temp Heating	= 70°F
Fluid Flow Required	= 9 GPM

FHP model LM036 would not be sufficient given these conditions as it provides a total cooling capacity of 38.0 MBTUH and a sensible capacity of 28.6 MBTUH. This meets the design conditions as closely as possible.

Please be aware that interpolation between ratings within a table is allowed, but extrapolation is a method of estimating new data by expanding outside a known range of data points and should not be considered accurate.

Operating Limits – Cooling & Heating	Standard Unit	Extended Range Option
Cooling		
Minimum ambient air temperature °F	50	50
Maximum ambient air temperature °F	100	100
Minimum evaporator entering air db/wb °F	68/57	68/57
Rated air coil entering air db/wb °F	80/67	80/67
Maximum evaporator entering air db/wb °F	95/85	95/85
Minimum water coil entering fluid temperature °F	70	40
Water loop typical coil entering fluid range temperature °F	70/90	70/90
Maximum water coil entering fluid temperature °F	110	110
Heating		
Minimum ambient air temperature °F	50	40
Maximum ambient air temperature °F	100	85
Minimum evaporator entering air db °F	50	50
Rated air coil entering air °F	68	68
Maximum evaporator entering air db °F	80	80
Normal water coil entering fluid range °F	50-80	25-80*
Minimum water coil entering Fluid °F	50	20*

* = antifreeze solution is required at these fluid temperatures.

Physical Data

Series LM Water Source Heat Pump

LM Series	LM024	LM036	LM048	LM060	LM070
Compressor Type (Qty 1)	Scroll	Scroll	Scroll	Scroll	Scroll
Refrigeration Charge VT (oz)	58	98	88	110	114
Refrigeration Charge HZ only (oz)	64	85	77	100	114
Max Water Working Pressure (PSIG/kPa)	450/3100	450/3100	450/3100	450/3100	450/3100
ECM Constant Torque					
Fan Motor Type/Speeds	ECM Const Torque / 5 speed	ECM Const Torque / 5 speed	ECM Const Torque / 5 speed	ECM Const Torque / 5 speed	ECM Const Torque / 5 speed
Fan Motor (HP)	0.33	0.75	0.75	1.00	1.00
Blower Wheel Size (Dia. x W)	10 X 8	11 X 9	11 X 9	11 X 11	11 X 11
ECM Constant CFM					
Fan Motor Type/Speeds	ECM Const Air Flow	ECM Const Air Flow	ECM Const Air Flow	ECM Const Air Flow	ECM Const Air Flow
Fan Motor (HP)	0.33	0.75	0.75	1.00	1.00
Blower Wheel Size (Dia. x W)	10 X 8	11 X 9	11 X 9	11 X 11	11 X 11
Water Connection Size					
FPT	3/4"	1.0"	1.0"	1.0"	1.0"
Coaxial Coil Volume (gal)	0.33	1.18	0.62	1.07	1.12
Vertical Cabinet					
Air Coil Dimensions (H x W)	24 X 20	32 X 26	32 X 26	38 X 26	38 x 26
Nominal size of Standard Filter - 1" MERV 5 (L x H)	24 X 24 (1)	16 X 30 (2)	16 X 30 (2)	20 X 30 (2)	20 X 30 (2)
Weight - Operating (lbs)	250	360	340	410	440
Weight - Shipping (lbs)	350	475	450	530	560
Horizontal Cabinet					
Air Coil Dimensions (H x W)	18 X 31.5	20 X 42	20 X 42	20 X 49	20 X 49
Nominal size of Standard Filter - 1" MERV 5 (L x H)	18 X 18 (2)	20 X 24 (2)	20 X 24 (2)	18 X 20 (3)	18 X 20 (3)
Weight - Operating (lbs)	260	375	355	430	460
Weight - Shipping (lbs)	360	495	470	550	580

Horizontal Cabinet Corner Weights

Configuration			Left Hand Evaporator				Right Hand Evaporator			
Model		Total	Left Front*	Right Front*	Left Back	Right Back	Left Front*	Right Front*	Left Back	Right Back
LM024	Lbs	283	60	74	68	61	60	74	61	68
	kg	128	27	34	31	28	27	33	28	31
LM036	Lbs	385	94	104	95	92	94	104	92	95
	kg	174	43	47	43	42	42	47	42	43
LM048	Lbs	361	84	109	88	81	84	109	81	88
	kg	164	38	49	40	37	38	49	37	40
LM060	Lbs	440	107	124	104	105	107	124	105	104
	kg	199	48	56	47	48	48	56	47	47
LM070	Lbs	469	117	136	105	111	117	136	111	105
	kg	212	53	62	48	50	53	62	50	48

NOTE: * Front is control box end.

Certified Performance Data

ASHRAE / AHRI / ISO 13256-1. English (I-P) Units													
Model		Water Loop Heat Pump				Ground Water Heat Pump				Ground Loop Heat Pump			
		Cooling 86 °F		Heating 68 °F		Cooling 59 °F		Heating 50 °F		Cooling 77 °F		Heating 32 °F	
		Capacity Btuh	EER Btuh/W	Capacity Btuh	COP	Capacity Btuh	EER Btuh/W	Capacity Btuh	COP	Capacity Btuh	EER Btuh/W	Capacity Btuh	COP
Full Load	LM024	25500	17.4	29200	5.6	29000	26.5	23500	4.9	26600	19.9	18000	4.1
	LM036	39000	19.0	42800	5.6	43300	28.0	35900	5.1	40800	22.0	28400	4.3
	LM048	49200	16.6	56100	5.3	55300	25.3	46300	4.7	51300	19.3	36900	4.0
	LM060	63800	17.0	73300	5.2	70200	24.4	60300	4.6	65100	18.9	48000	3.9
	LM070	71600	16.3	84000	5.1	78700	23.1	70000	4.5	73700	18.5	55300	3.8

Model	Cooling 86 °F		Heating 68 °F		Cooling 59 °F		Heating 50 °F		Cooling 68 °F		Heating 41 °F		
Part Load	LM024	18500	18.9	21200	6.5	21700	33.6	16700	5.1	21000	28.1	14400	4.4
	LM036	29000	22.2	31000	6.5	32600	37.0	25200	5.2	31900	32.0	22400	4.7
	LM048	36700	18.9	40900	6.2	42000	33.8	33700	5.2	39900	27.8	29800	4.5
	LM060	47500	18.7	53600	5.8	53300	31.2	44300	4.8	51600	26.5	39800	4.4
	LM070	55200	17.8	64900	5.7	60800	28.5	52900	4.8	60300	25.4	46900	4.3

Subject to change without prior notice.

Capacity Data

LM024 – Part Load (650 CFM @ 0.34" ESP)

COOLING									HEATING								
Entering Fluid Temp (°F)	Water Flow (GPM)	Pressure Drop PSI (FOH)	Entering Air Temp (db/wb) °F	Total Capacity (MBTUH)	Sensible Capacity (MBTUH)	Heat of Rejection (MBTUH)	Power Input (kW)	EER	Entering Fluid Temp (°F)	Pressure Drop PSI (FOH)	Entering Air Temp (°F)	Total Capacity (MBTUH)	Heat of Absorption (MBTUH)	Power Input (kW)	COP		
50	3	0.7 (1.7)	75/63	20.0	15.8	22.5	0.77	25.8	30	0.8 (1.8)	60	12.8	9.7	1.01	3.7		
			80/67	21.3	16.3	23.8	0.76	27.8			70	12.4	8.9	1.13	3.2		
			85/71	22.7	16.7	25.1	0.76	30.0			80	12.1	8.1	1.26	2.8		
	4	1.3 (2.9)	75/63	20.4	16.0	22.8	0.74	27.4		60	13.2	10.0	1.01	3.8			
			80/67	21.8	16.5	24.1	0.73	29.7		70	12.7	9.2	1.13	3.3			
			85/71	23.1	16.9	25.5	0.72	31.9		80	12.3	8.4	1.26	2.9			
	6	2.6 (5.9)	75/63	20.8	16.1	23.1	0.71	29.1		60	13.6	10.4	1.02	3.9			
			80/67	22.2	16.7	24.5	0.70	31.5		70	13.1	9.5	1.14	3.4			
			85/71	23.7	17.1	26.0	0.69	34.2		80	12.7	8.7	1.27	2.9			
60	3	0.7 (1.6)	75/63	19.0	15.4	21.7	0.86	22.1	40	0.8 (1.8)	60	14.8	11.6	1.03	4.2		
			80/67	20.3	15.9	22.9	0.85	23.9			70	14.4	10.8	1.15	3.7		
			85/71	21.5	16.3	24.2	0.84	25.5			80	14.0	9.9	1.28	3.2		
	4	1.2 (2.8)	75/63	19.4	15.6	22.0	0.82	23.5		60	15.3	12.0	1.03	4.4			
			80/67	20.7	16.1	23.3	0.81	25.4		70	14.9	11.1	1.15	3.8			
			85/71	22.0	16.5	24.6	0.80	27.3		80	14.3	10.3	1.28	3.3			
	6	2.5 (5.7)	75/63	19.8	15.7	22.3	0.79	24.9		60	15.7	12.5	1.03	4.5			
			80/67	21.1	16.2	23.6	0.78	27.0		70	15.3	11.5	1.15	3.9			
			85/71	22.5	16.7	25.0	0.77	29.3		80	14.7	10.7	1.29	3.4			
70	3	0.7 (1.6)	75/63	18.0	15.0	21.0	0.96	18.7	50	0.7 (1.7)	60	16.9	13.7	1.04	4.8		
			80/67	19.2	15.5	22.2	0.95	20.1			70	16.4	12.7	1.16	4.2		
			85/71	20.4	16.0	23.4	0.94	21.6			80	16.0	11.9	1.29	3.6		
	4	1.2 (2.7)	75/63	18.3	15.1	21.2	0.92	19.8		60	17.5	14.2	1.04	5.0			
			80/67	19.6	15.6	22.4	0.91	21.4		70	16.9	13.2	1.16	4.3			
			85/71	20.8	16.1	23.7	0.90	23.0		80	16.5	12.3	1.30	3.7			
	6	2.4 (5.5)	75/63	18.7	15.3	21.5	0.89	21.0		60	18.0	14.7	1.04	5.1			
			80/67	20.0	15.8	22.8	0.87	22.8		70	17.4	13.7	1.16	4.4			
			85/71	21.3	16.3	24.0	0.86	24.7		80	17.0	12.8	1.30	3.8			
80	3	0.6 (1.5)	75/63	17.0	14.5	20.2	1.08	15.8	60	0.7 (1.6)	60	19.1	15.8	1.04	5.4		
			80/67	18.1	15.1	21.4	1.07	16.9			70	18.5	14.8	1.17	4.7		
			85/71	19.2	15.6	22.5	1.06	18.1			80	18.1	13.9	1.31	4.1		
	4	1.1 (2.6)	75/63	17.3	14.7	20.5	1.04	16.6		60	19.7	16.4	1.04	5.6			
			80/67	18.4	15.2	21.6	1.03	17.9		70	19.1	15.4	1.17	4.8			
			85/71	19.6	15.7	22.8	1.02	19.2		80	18.6	14.4	1.31	4.2			
	6	2.3 (5.4)	75/63	17.6	14.8	20.7	1.00	17.6		60	20.4	17.1	1.04	5.8			
			80/67	18.9	15.3	21.9	0.99	19.1		70	19.7	16.0	1.17	5.0			
			85/71	20.1	15.9	23.1	0.97	20.6		80	19.1	14.9	1.31	4.3			
85	3	0.6 (1.5)	75/63	16.4	14.3	19.9	1.14	14.3	70	0.7 (1.6)	60	21.3	18.0	1.04	6.0		
			80/67	17.5	14.8	21.0	1.14	15.4			70	20.7	17.0	1.17	5.2		
			85/71	18.7	15.3	22.2	1.13	16.5			80	20.1	15.9	1.32	4.5		
	4	1.1 (2.5)	75/63	16.7	14.4	20.1	1.10	15.1		60	22.0	18.7	1.04	6.2			
			80/67	17.9	15.0	21.2	1.09	16.3		70	21.3	17.6	1.17	5.3			
			85/71	19.1	15.5	22.4	1.08	17.6		80	20.7	16.5	1.32	4.6			
	6	2.3 (5.3)	75/63	17.1	14.6	20.3	1.06	16.1		60	22.8	19.5	1.04	6.4			
			80/67	18.2	15.1	21.5	1.05	17.3		70	22.0	18.3	1.17	5.5			
			85/71	19.5	15.7	22.7	1.04	18.8		80	21.4	17.1	1.32	4.7			
90	3	0.6 (1.5)	75/63	15.9	14.1	19.5	1.21	13.1	80	0.7 (1.5)	60	23.5	20.3	1.04	6.7		
			80/67	17.0	14.6	20.6	1.21	14.1			70	22.9	19.2	1.17	5.8		
			85/71	18.0	15.2	21.7	1.20	15.0			80	22.3	18.0	1.32	4.9		
	4	1.1 (2.5)	75/63	16.2	14.2	19.7	1.17	13.8		60	24.4	21.1	1.03	6.9			
			80/67	17.3	14.7	20.9	1.16	14.9		70	23.6	19.9	1.17	5.9			
			85/71	18.5	15.2	22.0	1.15	16.0		80	22.9	18.7	1.32	5.1			
	6	2.3 (5.2)	75/63	16.5	14.3	19.9	1.13	14.6		60	25.2	22.1	1.03	7.2			
			80/67	17.7	14.9	21.1	1.12	15.8		70	24.4	20.8	1.16	6.2			
			85/71	18.9	15.4	22.3	1.11	17.1		80	23.7	19.5	1.32	5.3			
100	3	0.6 (1.4)	75/63	14.8	13.6	18.9	1.36	10.8	Extended Range - Anti-freeze required	AHR/ISO13256-1 certified performance is rated at entering air conditions of 80.6°F DB and 66.2°F WB in cooling and 68°F DB in heating. Tabulated unit performance does not include fan or pump power corrections required for AHR/ISO standard performance ratings. Unit performance may be interpolated. Extrapolation is not allowed. For conditions other than rating conditions provided, consult the FHP BST selection software. Ratings below 40°F are with a methanol solution. Due to variations in installation, actual performance may vary from the tabulated data. Performance contained herein are as a result of extensive testing by FHP and are not express warranties between the parties and may be changed at any time. Continuous research and development to improve our products may result in a change to the current design and specifications without notice.	1.0 (2.4)	75/63	13.7	13.2	18.3	1.53	8.9
			80/67	15.8	14.2	19.9	1.36	11.6				80/67	14.6	13.8	19.2	1.53	9.5
			85/71	16.8	14.8	21.0	1.35	12.4				85/71	15.6	14.3	20.3	1.53	10.2
	4	1.0 (2.4)	75/63	15.1	13.7	19.0	1.32	11.4			75/63	13.9	13.3	18.4	1.49	9.3	
			80/67	16.1	14.3	20.1	1.31	12.2			80/67	14.9	13.9	19.4	1.48	10.0	
			85/71	17.2	14.9	21.2	1.31	13.1			85/71	15.9	14.5	20.4	1.48	10.7	
	6	2.2 (5)	75/63	15.3	13.9	19.2	1.28	11.9			75/63	14.2	13.4	18.5	1.45	9.8	
			80/67	16.5	14.4	20.3	1.27	13.0			80/67	15.2	14.0	19.6	1.44	10.5	
			85/71	17.6	15.0	21.5	1.26	14.0			85/71	16.3	14.5	20.7	1.43	11.4	
110	3	0.6 (1.4)	75/63	13.7	13.2	18.3	1.53	8.9	110	2.1 (4.9)	75/63	14.2	13.4	18.5	1.45	9.8	
			80/67	14.6	13.8	19.2	1.53	9.5			80/67	15.2	14.0	19.6	1.44	10.5	
			85/71	15.6	14.3	20.3	1.53	10.2			85/71	16.3	14.5	20.7	1.43	11.4	
	4	1.0 (2.4)	75/63	13.9	13.3	18.4	1.49	9.3		75/63	14.2	13.4	18.5	1.45	9.8		
			80/67	14.9	13.9	19.4	1.48	10.0		80/67	15.2	14.0	19.6	1.44	10.5		
			85/71	15.9	14.5	20.4	1.48	10.7		85/71	16.3	14.5	20.7	1.43	11.4		
	6	2.1 (4.9)	75/63	14.2	13.4	18.5	1.45	9.8		75/63	14.2	13.4	18.5	1.45	9.8		
			80/67	15.2	14.0	19.6	1.44	10.5		80/67	15.2	14.0	19.6	1.44	10.5		
			85/71	16.3	14.5	20.7	1.43	11.4		85/71	16.3	14.5	20.7	1.43	11.4		

Extended Range - Anti-freeze required
 AHR/ISO13256-1 certified performance is rated at entering air conditions of 80.6°F DB and 66.2°F WB in cooling and 68°F DB in heating.
 Tabulated unit performance does not include fan or pump power corrections required for AHR/ISO standard performance ratings.
 Unit performance may be interpolated. Extrapolation is not allowed.
 For conditions other than rating conditions provided, consult the FHP BST selection software.
 Ratings below 40°F are with a methanol solution.
 Due to variations in installation, actual performance may vary from the tabulated data. Performance contained herein are as a result of extensive testing by FHP and are not express warranties between the parties and may be changed at any time.
 Continuous research and development to improve our products may result in a change to the current design and specifications without notice.



Capacity Data

LM024 – Full Load (825 CFM @ 0.23" ESP)

COOLING									HEATING						
Entering Fluid Temp (°F)	Water Flow (GPM)	Pressure Drop PSI (FOH)	Entering Air Temp (db/wb) °F	Total Capacity (MBTUH)	Sensible Capacity (MBTUH)	Heat of Rejection (MBTUH)	Power Input (kW)	EER	Entering Fluid Temp (°F)	Pressure Drop PSI (FOH)	Entering Air Temp (°F)	Total Capacity (MBTUH)	Heat of Absorption (MBTUH)	Power Input (kW)	COP
50	3	0.7 (1.7)	75/63	27.1	20.7	31.3	1.27	21.4	30	0.8 (1.8)	18.1	13.6	1.38	3.8	3.8
			80/67	28.8	21.2	33.1	1.29	22.4			17.7	12.7	1.52	3.4	3.4
			85/71	30.5	21.8	34.9	1.30	23.4			17.4	11.8	1.67	3.0	3.0
	4	1.3 (2.9)	75/63	27.8	21.0	31.8	1.21	23.1		1.3 (3.1)	18.7	14.1	1.39	3.9	3.9
			80/67	29.5	21.6	33.6	1.22	24.2			18.2	13.2	1.53	3.5	3.5
			85/71	31.4	22.1	35.6	1.24	25.4			17.9	12.2	1.68	3.1	3.1
	6	2.6 (5.9)	75/63	28.5	21.3	32.3	1.14	25.1		2.8 (6.4)	19.4	14.7	1.41	4.0	4.0
			80/67	30.3	21.9	34.2	1.15	26.3			18.8	13.8	1.54	3.6	3.6
			85/71	32.3	22.4	36.2	1.16	27.8			18.4	12.7	1.69	3.2	3.2
60	3	0.7 (1.6)	75/63	25.9	20.1	30.4	1.38	18.8	40	0.8 (1.8)	20.5	15.8	1.43	4.2	4.2
			80/67	27.5	20.8	32.0	1.40	19.7			20.0	14.8	1.57	3.7	3.7
			85/71	29.2	21.3	33.9	1.42	20.7			19.6	13.9	1.72	3.3	3.3
	4	1.2 (2.8)	75/63	26.5	20.4	30.9	1.32	20.1		1.3 (3.0)	21.2	16.5	1.44	4.3	4.3
			80/67	28.2	21.0	32.6	1.34	21.1			20.7	15.5	1.58	3.8	3.8
			85/71	30.0	21.6	34.5	1.35	22.2			20.2	14.5	1.74	3.4	3.4
	6	2.5 (5.7)	75/63	27.2	20.7	31.3	1.26	21.6		2.7 (6.1)	22.1	17.3	1.46	4.4	4.4
			80/67	29.0	21.3	33.2	1.27	22.8			21.5	16.2	1.60	3.9	3.9
			85/71	30.9	21.9	35.1	1.28	24.1			20.9	15.2	1.75	3.5	3.5
70	3	0.7 (1.6)	75/63	24.6	19.6	29.4	1.50	16.5	50	0.7 (1.7)	23.1	18.2	1.48	4.6	4.6
			80/67	26.2	20.2	31.1	1.52	17.3			22.6	17.2	1.62	4.1	4.1
			85/71	27.8	20.8	32.7	1.53	18.2			22.2	16.2	1.78	3.6	3.6
	4	1.2 (2.7)	75/63	25.2	19.9	29.9	1.44	17.6		1.2 (2.9)	24.0	19.1	1.50	4.7	4.7
			80/67	26.8	20.5	31.6	1.46	18.4			23.4	18.0	1.64	4.2	4.2
			85/71	28.6	21.0	33.4	1.47	19.5			23.0	16.8	1.80	3.7	3.7
	6	2.4 (5.5)	75/63	25.9	20.1	30.4	1.38	18.8		2.6 (5.9)	25.1	20.0	1.52	4.8	4.8
			80/67	27.5	20.8	32.1	1.39	19.8			24.4	18.9	1.66	4.3	4.3
			85/71	29.3	21.4	33.9	1.40	20.9			23.8	17.7	1.82	3.8	3.8
80	3	0.6 (1.5)	75/63	23.3	19.1	28.5	1.63	14.4	60	0.7 (1.6)	25.9	20.8	1.54	4.9	4.9
			80/67	24.8	19.7	30.1	1.65	15.1			25.3	19.8	1.68	4.4	4.4
			85/71	26.3	20.2	31.7	1.66	15.9			24.9	18.6	1.84	4.0	4.0
	4	1.1 (2.6)	75/63	23.9	19.3	28.9	1.57	15.3		1.2 (2.8)	27.0	21.9	1.56	5.1	5.1
			80/67	25.4	19.9	30.5	1.58	16.1			26.3	20.8	1.70	4.5	4.5
			85/71	27.1	20.5	32.3	1.60	17.0			25.8	19.5	1.85	4.1	4.1
	6	2.3 (5.4)	75/63	24.5	19.5	29.4	1.51	16.3		2.5 (5.7)	28.2	23.1	1.58	5.2	5.2
			80/67	26.1	20.2	31.0	1.52	17.2			27.5	21.8	1.72	4.7	4.7
			85/71	27.8	20.8	32.8	1.53	18.2			26.8	20.5	1.87	4.2	4.2
85	3	0.6 (1.5)	75/63	22.7	18.8	28.1	1.70	13.4	70	0.7 (1.6)	28.9	23.6	1.59	5.3	5.3
			80/67	24.1	19.4	29.6	1.72	14.1			28.2	22.5	1.73	4.8	4.8
			85/71	25.6	20.1	31.1	1.73	14.8			27.6	21.3	1.89	4.3	4.3
	4	1.1 (2.5)	75/63	23.2	19.1	28.4	1.64	14.2		1.2 (2.7)	30.1	24.8	1.61	5.5	5.5
			80/67	24.7	19.6	30.0	1.65	15.0			29.4	23.7	1.75	4.9	4.9
			85/71	26.3	20.2	31.7	1.67	15.8			28.7	22.3	1.91	4.4	4.4
	6	2.3 (5.3)	75/63	23.8	19.3	28.9	1.57	15.2		2.4 (5.5)	31.6	26.2	1.63	5.7	5.7
			80/67	25.4	19.9	30.5	1.59	16.0			30.7	24.9	1.78	5.1	5.1
			85/71	27.1	20.5	32.3	1.60	17.0			29.9	23.4	1.93	4.5	4.6
90	3	0.6 (1.5)	75/63	22.0	18.6	27.6	1.77	12.4	80	0.7 (1.5)	31.9	26.5	1.64	5.7	5.8
			80/67	23.4	19.1	29.1	1.79	13.1			31.1	25.3	1.78	5.1	5.1
			85/71	24.9	19.7	30.7	1.81	13.8			30.5	24.0	1.94	4.6	4.6
	4	1.1 (2.5)	75/63	22.6	18.7	28.0	1.71	13.2		1.1 (2.6)	33.4	27.9	1.66	5.9	5.9
			80/67	24.0	19.4	29.5	1.73	13.9			32.5	26.6	1.81	5.3	5.3
			85/71	25.5	20.0	31.1	1.74	14.7			31.7	25.1	1.97	4.7	4.7
	6	2.3 (5.2)	75/63	23.1	19.0	28.3	1.65	14.1		2.3 (5.4)	35.0	29.5	1.69	6.1	6.1
			80/67	24.6	19.6	30.0	1.66	14.8			34.0	28.0	1.83	5.4	5.4
			85/71	26.3	20.2	31.7	1.67	15.8			33.1	26.4	2.00	4.9	4.9
100	3	0.6 (1.4)	75/63	20.6	18.0	26.8	1.94	10.6	Extended Range - Anti-freeze required	AHRI/ISO 13256-1 certified performance is rated at entering air conditions of 80.6°F DB and 66.2°F WB in cooling and 68°F DB in heating. Tabulated unit performance does not include fan or pump power corrections required for AHRI/ISO standard performance ratings. Unit performance may be interpolated. Extrapolation is not allowed. For conditions other than rating conditions provided, consult the FHP BST selection software. Ratings below 40°F are with a methanol solution. Due to variations in installation, actual performance may vary from the tabulated data. Performance contained herein are as a result of extensive testing by FHP and are not express warranties between the parties and may be changed at any time. Continuous research and development to improve our products may result in a change to the current design and specifications without notice.	AHRICERTIFIED™ www.ahrirectory.org	Intertek			
			80/67	22.0	18.7	28.2	1.96	11.3							
			85/71	23.4	19.3	29.7	1.97	11.9							
	4	1.0 (2.4)	75/63	21.1	18.2	27.1	1.88	11.3							
			80/67	22.5	18.9	28.6	1.89	11.9							
			85/71	24.0	19.5	30.1	1.90	12.7							
	6	2.2 (5)	75/63	21.7	18.4	27.4	1.81	12.0							
			80/67	23.2	19.0	29.0	1.82	12.8							
			85/71	24.6	19.7	30.5	1.83	13.5							
110	3	0.6 (1.4)	75/63	19.3	17.5	26.0	2.14	9.1							
			80/67	20.6	18.2	27.4	2.15	9.6							
			85/71	22.0	18.7	28.9	2.17	10.2							
	4	1.0 (2.4)	75/63	19.8	17.7	26.3	2.07	9.6							
			80/67	21.1	18.3	27.7	2.08	10.2							
			85/71	22.5	19.0	29.2	2.09	10.8							
	6	2.1 (4.9)	75/63	20.2	17.9	26.5	2.00	10.1							
			80/67	21.7	18.5	28.1	2.00	10.9							
			85/71	23.2	19.1	29.6	2.01	11.6							

Extended Range - Anti-freeze required

AHRI/ISO 13256-1 certified performance is rated at entering air conditions of 80.6°F DB and 66.2°F WB in cooling and 68°F DB in heating.

Tabulated unit performance does not include fan or pump power corrections required for AHRI/ISO standard performance ratings.

Unit performance may be interpolated. Extrapolation is not allowed.

For conditions other than rating conditions provided, consult the FHP BST selection software.

Ratings below 40°F are with a methanol solution.

Due to variations in installation, actual performance may vary from the tabulated data. Performance contained herein are as a result of extensive testing by FHP and are not express warranties between the parties and may be changed at any time.

Continuous research and development to improve our products may result in a change to the current design and specifications without notice.



Capacity Data

LM036 – Part Load (800 CFM @ 0.58" ESP)

COOLING									HEATING						
Entering Fluid Temp (°F)	Water Flow (GPM)	Pressure Drop PSI (FOH)	Entering Air Temp (db/wb) °F	Total Capacity (MBTUH)	Sensible Capacity (MBTUH)	Heat of Rejection (MBTUH)	Power Input (kW)	EER	Entering Fluid Temp (°F)	Pressure Drop PSI (FOH)	Entering Air Temp (°F)	Total Capacity (MBTUH)	Heat of Absorption (MBTUH)	Power Input (kW)	COP
50	4.5	1.4 (3.2)	75/63	29.9	21.8	33.2	1.01	29.6	30	1.5 (3.4)	60	18.4	13.6	1.46	3.7
			80/67	32.0	22.5	35.3	1.00	32.1			70	18.0	12.6	1.65	3.2
			85/71	34.2	23.0	37.4	0.98	34.9			80	17.7	11.5	1.86	2.8
	6	2.3 (5.4)	75/63	30.4	22.0	33.6	0.99	30.9			60	18.9	14.0	1.47	3.8
			80/67	32.5	22.7	35.7	0.97	33.6			70	18.4	12.9	1.65	3.3
			85/71	34.8	23.2	37.9	0.95	36.7			80	18.0	11.7	1.87	2.8
	9	4.8 (11.1)	75/63	30.8	22.2	34.0	0.96	32.0			60	19.3	14.5	1.47	3.8
			80/67	33.1	22.9	36.2	0.94	35.1			70	18.9	13.4	1.65	3.3
			85/71	35.4	23.5	38.5	0.92	38.5			80	18.3	12.4	1.87	2.9
60	4.5	1.3 (3.1)	75/63	28.5	21.2	32.1	1.11	25.7	40	1.4 (3.3)	60	21.3	16.4	1.48	4.2
			80/67	30.5	21.9	34.1	1.10	27.9			70	20.8	15.3	1.67	3.7
			85/71	32.7	22.4	36.2	1.08	30.3			80	20.4	14.1	1.88	3.2
	6	2.3 (5.2)	75/63	29.0	21.4	32.5	1.07	27.0			60	21.9	17.0	1.49	4.3
			80/67	31.0	22.1	34.5	1.06	29.3			70	21.3	15.8	1.67	3.7
			85/71	33.3	22.6	36.7	1.04	32.0			80	20.8	14.6	1.89	3.2
	9	4.6 (10.7)	75/63	29.4	21.6	32.8	1.04	28.2			60	22.5	17.6	1.49	4.4
			80/67	31.6	22.3	34.9	1.02	30.9			70	21.9	16.3	1.68	3.8
			85/71	33.8	22.9	37.2	1.00	33.7			80	21.4	15.1	1.89	3.3
70	4.5	1.3 (3)	75/63	27.1	20.6	31.0	1.24	22.0	50	1.4 (3.2)	60	24.4	19.5	1.50	4.8
			80/67	29.1	21.2	33.0	1.23	23.8			70	23.8	18.2	1.69	4.1
			85/71	31.1	21.9	35.0	1.21	25.7			80	23.4	17.0	1.91	3.6
	6	2.2 (5)	75/63	27.5	20.8	31.3	1.19	23.0			60	25.1	20.2	1.51	4.9
			80/67	29.6	21.4	33.4	1.18	25.1			70	24.4	18.8	1.70	4.2
			85/71	31.6	22.1	35.4	1.16	27.2			80	23.9	17.5	1.92	3.6
	9	4.5 (10.4)	75/63	27.9	21.0	31.6	1.16	24.2			60	25.9	20.9	1.51	5.0
			80/67	30.0	21.6	33.7	1.14	26.4			70	25.1	19.5	1.70	4.3
			85/71	32.2	22.2	35.9	1.12	28.8			80	24.6	18.1	1.92	3.7
80	4.5	1.3 (2.9)	75/63	25.7	19.9	30.1	1.39	18.5	60	1.3 (3.1)	60	27.6	22.6	1.52	5.3
			80/67	27.5	20.6	31.9	1.38	19.9			70	26.9	21.2	1.72	4.6
			85/71	29.5	21.3	33.9	1.38	21.5			80	26.4	19.8	1.94	4.0
	6	2.1 (4.8)	75/63	26.1	20.1	30.3	1.35	19.4			60	28.5	23.5	1.52	5.5
			80/67	28.0	20.8	32.2	1.33	21.0			70	27.7	22.0	1.72	4.7
			85/71	30.0	21.4	34.3	1.32	22.7			80	27.0	20.5	1.95	4.0
	9	4.4 (10.1)	75/63	26.4	20.3	30.6	1.30	20.3			60	29.4	24.4	1.53	5.6
			80/67	28.5	20.9	32.6	1.29	22.2			70	28.5	22.8	1.73	4.8
			85/71	30.5	21.6	34.6	1.27	24.1			80	27.8	21.3	1.96	4.2
85	4.5	1.2 (2.8)	75/63	24.9	19.6	29.6	1.48	16.8	70	1.3 (3.0)	60	30.9	25.9	1.54	5.9
			80/67	26.8	20.3	31.5	1.48	18.2			70	30.0	24.3	1.74	5.0
			85/71	28.7	20.9	33.4	1.47	19.6			80	29.6	22.6	1.98	4.4
	6	2.1 (4.8)	75/63	25.3	19.8	29.8	1.43	17.7			60	31.9	26.9	1.54	6.1
			80/67	27.2	20.5	31.7	1.42	19.1			70	31.0	25.3	1.75	5.2
			85/71	29.1	21.2	33.7	1.41	20.7			80	30.3	23.6	1.99	4.5
	9	4.3 (9.9)	75/63	25.7	19.9	30.1	1.39	18.5			60	33.0	28.0	1.55	6.3
			80/67	27.6	20.7	32.0	1.37	20.1			70	32.0	26.3	1.76	5.3
			85/71	29.7	21.3	34.0	1.36	21.9			80	31.2	24.4	2.00	4.6
90	4.5	1.2 (2.8)	75/63	24.2	19.3	29.1	1.58	15.3	80	1.2 (2.9)	60	34.2	29.0	1.55	6.5
			80/67	25.9	20.0	30.9	1.57	16.5			70	33.2	27.6	1.77	5.5
			85/71	27.8	20.7	32.8	1.57	17.8			80	32.8	25.8	2.02	4.8
	6	2.0 (4.7)	75/63	24.5	19.5	29.3	1.53	16.0			60	35.4	30.5	1.56	6.7
			80/67	26.4	20.1	31.2	1.52	17.4			70	34.4	28.6	1.78	5.7
			85/71	28.3	20.8	33.2	1.51	18.8			80	33.8	27.1	2.03	4.9
	9	4.2 (9.7)	75/63	24.9	19.5	29.6	1.49	16.7			60	36.7	31.8	1.56	6.9
			80/67	26.8	20.3	31.5	1.47	18.3			70	35.6	29.9	1.79	5.8
			85/71	28.8	21.0	33.4	1.45	19.9			80	34.7	27.7	2.04	5.0
100	4.5	1.2 (2.7)	75/63	22.7	18.7	28.3	1.80	12.6	Extended Range - Anti-freeze required	1.1 (2.6)	60	37.7	33.4	1.57	7.1
			80/67	24.4	19.4	30.0	1.79	13.6			70	36.7	31.8	1.79	6.1
			85/71	26.1	20.1	31.8	1.79	14.6			80	35.7	30.2	2.01	5.1
	6	2.0 (4.6)	75/63	23.0	18.9	28.5	1.75	13.2			60	38.7	34.4	1.57	7.1
			80/67	24.8	19.6	30.2	1.74	14.3			70	37.7	32.8	1.79	6.1
			85/71	26.6	20.2	32.1	1.73	15.4			80	36.7	31.2	2.01	5.1
	9	4.1 (9.5)	75/63	23.3	18.9	28.6	1.71	13.6			60	40.7	36.0	1.57	7.1
			80/67	25.1	19.7	30.4	1.68	14.9			70	39.7	34.4	1.79	6.1
			85/71	27.1	20.3	32.4	1.67	16.3			80	38.7	32.8	2.01	5.1
110	4.5	1.1 (2.6)	75/63	21.1	18.1	27.5	2.05	10.3	Extended Range - Anti-freeze required	1.1 (2.6)	60	41.7	37.4	1.57	7.1
			80/67	22.8	18.8	29.2	2.04	11.2			70	40.7	35.8	1.79	6.1
			85/71	24.5	19.5	30.9	2.04	12.0			80	39.7	34.2	2.01	5.1
	6	1.9 (4.4)	75/63	21.4	18.2	27.7	1.99	10.7			60	43.7	39.1	1.57	7.1
			80/67	23.1	18.9	29.4	1.98	11.7			70	42.7	37.5	1.79	6.1
			85/71	24.9	19.6	31.1	1.97	12.6			80	41.7	35.9	2.01	5.1
	9	4.0 (9.2)	75/63	21.7	18.3	27.8	1.95	11.1			60	45.7	41.0	1.57	7.1
			80/67	23.4	19.0	29.5	1.94	12.1			70	44.7	39.4	1.79	6.1
			85/71	25.2	19.8	31.2	1.92	13.2			80	43.7	37.8	2.01	5.1

Extended Range - Anti-freeze required
 AHR/ISO13256-1 certified performance is rated at entering air conditions of 80.6°F DB and 66.2°F WB in cooling and 68°F DB in heating.
 Tabulated unit performance does not include fan or pump power corrections required for AHR/ISO standard performance ratings.
 Unit performance may be interpolated. Extrapolation is not allowed.
 For conditions other than rating conditions provided, consult the FHP BST selection software.
 Ratings below 40°F are with a methanol solution.
 Due to variations in installation, actual performance may vary from the tabulated data. Performance contained herein are as a result of extensive testing by FHP and are not express warranties between the parties and may be changed at any time.
 Continuous research and development to improve our products may result in a change to the current design and specifications without notice.



Capacity Data

LM036 – Full Load (1100 CFM @ 0.25" ESP)

COOLING									HEATING						
Entering Fluid Temp (°F)	Water Flow (GPM)	Pressure Drop PSI (FOH)	Entering Air Temp (db/wb) °F	Total Capacity (MBTUH)	Sensible Capacity (MBTUH)	Heat of Rejection (MBTUH)	Power Input (kW)	EER	Entering Fluid Temp (°F)	Pressure Drop PSI (FOH)	Entering Air Temp (°F)	Total Capacity (MBTUH)	Heat of Absorption (MBTUH)	Power Input (kW)	COP
50	4.5	1.4 (3.2)	75/63	40.8	29.9	46.4	1.69	24.1	30	1.5 (3.4)	60	26.0	19.5	1.93	3.9
			80/67	43.5	30.6	49.2	1.74	25.1			70	25.6	18.4	2.15	3.5
			85/71	46.3	31.4	52.2	1.78	26.1			80	25.4	17.2	2.40	3.1
	6	2.3 (5.4)	75/63	41.6	30.2	47.0	1.64	25.4		2.5 (5.7)	60	26.8	20.3	1.95	4.0
			80/67	44.4	31.0	49.9	1.69	26.4			70	26.4	19.1	2.17	3.6
			85/71	47.3	31.7	53.0	1.73	27.4			80	26.1	17.9	2.42	3.2
	9	4.8 (11.1)	75/63	42.3	30.5	47.6	1.60	26.5		5.2 (11.9)	60	27.8	21.2	1.97	4.1
			80/67	45.2	31.4	50.7	1.64	27.6			70	27.2	19.9	2.19	3.6
			85/71	48.3	32.1	53.9	1.69	28.7			80	26.8	18.6	2.43	3.2
60	4.5	1.3 (3.1)	75/63	39.2	29.1	45.1	1.82	21.6	40	1.4 (3.3)	60	29.7	22.9	2.01	4.3
			80/67	41.7	30.0	47.8	1.86	22.5			70	29.2	21.7	2.23	3.8
			85/71	44.5	30.6	50.7	1.89	23.5			80	28.7	20.4	2.48	3.4
	6	2.3 (5.2)	75/63	39.9	29.4	45.7	1.76	22.7		2.4 (5.5)	60	30.7	23.9	2.03	4.4
			80/67	42.6	30.3	48.5	1.80	23.7			70	30.1	22.5	2.25	3.9
			85/71	45.4	31.0	51.4	1.83	24.8			80	29.6	21.2	2.50	3.5
	9	4.6 (10.7)	75/63	40.7	29.8	46.2	1.71	23.9		5.0 (11.5)	60	31.9	25.0	2.05	4.6
			80/67	43.4	30.5	49.2	1.74	24.9			70	31.2	23.5	2.28	4.0
			85/71	46.3	31.4	52.2	1.78	26.1			80	30.5	22.0	2.52	3.5
70	4.5	1.3 (3)	75/63	37.5	28.4	43.9	1.98	19.0	50	1.4 (3.2)	60	33.6	26.6	2.09	4.7
			80/67	39.9	29.2	46.5	2.01	19.9			70	33.0	25.2	2.32	4.2
			85/71	42.6	29.9	49.3	2.04	20.9			80	32.5	23.7	2.57	3.7
	6	2.2 (5)	75/63	38.1	28.7	44.3	1.91	20.0		2.3 (5.4)	60	34.9	27.8	2.12	4.8
			80/67	40.8	29.5	47.1	1.94	21.1			70	34.2	26.3	2.34	4.3
			85/71	43.4	30.3	49.9	1.97	22.1			80	33.6	24.7	2.59	3.8
	9	4.5 (10.4)	75/63	38.8	29.0	44.8	1.85	21.0		4.8 (11.1)	60	36.3	29.1	2.15	4.9
			80/67	41.5	29.8	47.7	1.87	22.2			70	35.5	27.5	2.37	4.4
			85/71	44.3	30.7	50.6	1.90	23.3			80	34.8	25.9	2.62	3.9
80	4.5	1.3 (2.9)	75/63	35.7	27.6	42.6	2.16	16.5	60	1.3 (3.1)	60	37.8	30.5	2.18	5.1
			80/67	38.1	28.4	45.2	2.19	17.4			70	37.0	28.9	2.40	4.5
			85/71	40.6	29.2	47.9	2.22	18.3			80	36.4	27.4	2.65	4.0
	6	2.1 (4.8)	75/63	36.4	27.8	43.2	2.09	17.4		2.2 (5.2)	60	39.4	31.9	2.21	5.2
			80/67	38.9	28.7	45.7	2.11	18.4			70	38.4	30.2	2.43	4.6
			85/71	41.4	29.6	48.4	2.14	19.4			80	37.7	28.5	2.68	4.1
	9	4.4 (10.1)	75/63	37.0	28.1	43.6	2.02	18.3		4.6 (10.7)	60	41.1	33.5	2.25	5.4
			80/67	39.5	29.0	46.2	2.04	19.4			70	40.0	31.7	2.47	4.8
			85/71	42.3	29.9	49.0	2.06	20.6			80	39.1	29.8	2.71	4.2
85	4.5	1.2 (2.8)	75/63	34.8	27.2	42.1	2.27	15.3	70	1.3 (3.0)	60	42.2	34.6	2.27	5.4
			80/67	37.1	28.1	44.5	2.30	16.2			70	41.3	32.9	2.49	4.9
			85/71	39.6	28.8	47.2	2.32	17.1			80	40.5	31.1	2.75	4.3
	6	2.1 (4.8)	75/63	35.4	27.5	42.5	2.19	16.2		2.2 (5.0)	60	44.0	36.3	2.31	5.6
			80/67	37.9	28.3	45.1	2.22	17.1			70	42.9	34.4	2.53	5.0
			85/71	40.5	29.1	47.8	2.24	18.1			80	41.9	32.5	2.78	4.4
	9	4.3 (9.9)	75/63	36.0	27.5	42.9	2.13	16.9		4.5 (10.4)	60	46.0	38.1	2.36	5.7
			80/67	38.6	28.6	45.6	2.14	18.0			70	44.7	36.1	2.57	5.1
			85/71	41.3	29.5	48.3	2.16	19.2			80	43.6	34.0	2.82	4.5
90	4.5	1.2 (2.8)	75/63	33.9	26.8	41.6	2.39	14.2	80	1.2 (2.9)	60	46.7	38.8	2.37	5.8
			80/67	36.2	27.6	44.0	2.41	15.0			70	45.7	36.9	2.59	5.2
			85/71	38.6	28.6	46.4	2.43	15.9			80	44.7	35.0	2.85	4.6
	6	2.0 (4.7)	75/63	34.6	27.1	42.0	2.30	15.0		2.1 (4.8)	60	48.8	40.7	2.42	5.9
			80/67	36.9	27.9	44.5	2.33	15.9			70	47.5	38.7	2.64	5.3
			85/71	39.5	28.8	47.1	2.34	16.9			80	46.4	36.6	2.89	4.7
	9	4.2 (9.7)	75/63	35.1	27.4	42.2	2.23	15.8		4.4 (10.1)	60	51.1	42.8	2.48	6.0
			80/67	37.6	28.2	44.9	2.25	16.7			70	49.6	40.6	2.69	5.4
			85/71	40.2	29.1	47.5	2.26	17.8			80	48.3	38.4	2.94	4.8
100	4.5	1.2 (2.7)	75/63	32.0	26.1	40.5	2.64	12.1	Extended Range - Anti-freeze required	1.2 (2.9)	60	46.7	38.8	2.37	5.8
			80/67	34.3	26.9	42.9	2.67	12.9			70	45.7	36.9	2.59	5.2
			85/71	36.5	27.8	45.2	2.69	13.6			80	44.7	35.0	2.85	4.6
	6	2.0 (4.6)	75/63	32.7	26.3	40.9	2.56	12.8		2.1 (4.8)	60	48.8	40.7	2.42	5.9
			80/67	35.0	27.1	43.2	2.58	13.6			70	47.5	38.7	2.64	5.3
			85/71	37.4	28.0	45.7	2.59	14.5			80	46.4	36.6	2.89	4.7
	9	4.1 (9.5)	75/63	33.2	26.5	41.1	2.49	13.4		4.4 (10.1)	60	51.1	42.8	2.48	6.0
			80/67	35.5	27.3	43.6	2.51	14.2			70	49.6	40.6	2.69	5.4
			85/71	38.0	28.3	46.0	2.50	15.2			80	48.3	38.4	2.94	4.8
110	4.5	1.1 (2.6)	75/63	30.2	25.3	39.6	2.93	10.3	Extended Range - Anti-freeze required	1.2 (2.9)	60	46.7	38.8	2.37	5.8
			80/67	32.4	26.2	41.8	2.95	11.0			70	45.7	36.9	2.59	5.2
			85/71	34.6	27.1	44.1	2.97	11.6			80	44.7	35.0	2.85	4.6
	6	1.9 (4.4)	75/63	30.7	25.5	39.8	2.85	10.8		2.1 (4.8)	60	48.8	40.7	2.42	5.9
			80/67	32.9	26.5	42.1	2.86	11.5			70	47.5	38.7	2.64	5.3
			85/71	35.2	27.4	44.5	2.87	12.3			80	46.4	36.6	2.89	4.7
	9	4.0 (9.2)	75/63	31.3	25.7	40.1	2.77	11.3		4.4 (10.1)	60	51.1	42.8	2.48	6.0
			80/67	33.5	26.7	42.4	2.78	12.1			70	49.6	40.6	2.69	5.4
			85/71	35.9	27.5	44.9	2.79	12.9			80	48.3	38.4	2.94	4.8

Extended Range - Anti-freeze required
 AHRI/ISO13256-1 certified performance is rated at entering air conditions of 80.6°F DB and 66.2°F WB in cooling and 68°F DB in heating.
 Tabulated unit performance does not include fan or pump power corrections required for AHRI/ISO standard performance ratings.
 Unit performance may be interpolated. Extrapolation is not allowed.
 For conditions other than rating conditions provided, consult the FHP BST selection software.
 Ratings below 40°F are with a methanol solution.
 Due to variations in installation, actual performance may vary from the tabulated data. Performance contained herein are as a result of extensive testing by FHP and are not express warranties between the parties and may be changed at any time.
 Continuous research and development to improve our products may result in a change to the current design and specifications without notice.



Capacity Data

LM048 – Part Load (1300 CFM @ 0.27" ESP)

COOLING									HEATING						
Entering Fluid Temp (°F)	Water Flow (GPM)	Pressure Drop PSI (FOH)	Entering Air Temp (db/wb) °F	Total Capacity (MBTUH)	Sensible Capacity (MBTUH)	Heat of Rejection (MBTUH)	Power Input (kW)	EER	Entering Fluid Temp (°F)	Pressure Drop PSI (FOH)	Entering Air Temp (°F)	Total Capacity (MBTUH)	Heat of Absorption (MBTUH)	Power Input (kW)	COP
50	6	1.1 (2.6)	75/63	39.7	31.6	44.4	1.44	27.5							
			80/67	42.4	32.5	47.1	1.42	29.9							
			85/71	45.2	33.4	49.8	1.39	32.5							
	8	1.9 (4.4)	75/63	40.6	31.9	45.1	1.37	29.7							
			80/67	43.4	32.9	47.8	1.34	32.5							
			85/71	46.2	33.9	50.5	1.30	35.4							
	12	3.9 (9.1)	75/63	41.6	32.3	45.8	1.29	32.3							
			80/67	44.5	33.3	48.6	1.25	35.6							
			85/71	47.4	34.3	51.4	1.21	39.1							
30	1.2 (2.8)	60	25.7	19.3	1.95	3.9									
		70	24.9	17.7	2.18	3.4									
		80	24.1	16.1	2.43	2.9									
	2.0 (4.7)	60	26.4	20.0	1.95	4.0									
		70	25.5	18.3	2.18	3.4									
		80	24.7	16.6	2.44	3.0									
	4.2 (9.8)	60	27.2	20.8	1.95	4.1									
		70	26.2	19.0	2.18	3.5									
		80	25.2	17.2	2.44	3.0									
40	1.2 (2.7)	60	29.4	22.9	1.96	4.4									
		70	28.5	21.2	2.20	3.8									
		80	27.6	19.4	2.46	3.3									
40	2.0 (4.6)	60	30.3	23.8	1.96	4.5									
		70	29.3	22.0	2.20	3.9									
		80	28.3	20.1	2.47	3.4									
40	4.1 (9.5)	60	31.3	24.8	1.96	4.7									
		70	30.2	22.8	2.21	4.0									
		80	29.1	20.9	2.47	3.4									
50	1.1 (2.6)	60	33.3	26.8	1.97	5.0									
		70	32.4	25.0	2.22	4.3									
		80	31.4	23.1	2.49	3.7									
	1.9 (4.4)	60	34.4	27.9	1.97	5.1									
		70	33.3	25.9	2.22	4.4									
		80	32.4	24.0	2.50	3.8									
	4.0 (9.1)	60	35.6	29.1	1.97	5.3									
		70	34.4	27.0	2.23	4.5									
		80	33.4	25.0	2.51	3.9									
60	1.1 (2.5)	60	37.6	31.0	1.98	5.6									
		70	36.5	29.1	2.24	4.8									
		80	35.5	27.1	2.51	4.1									
	1.8 (4.3)	60	38.9	32.3	1.98	5.7									
		70	37.7	30.2	2.24	4.9									
		80	36.6	28.2	2.52	4.3									
	3.8 (8.8)	60	40.3	33.8	1.98	6.0									
		70	39.0	31.6	2.24	5.1									
		80	37.8	29.4	2.52	4.4									
70	1.1 (2.5)	60	42.1	35.5	1.99	6.2									
		70	40.9	33.4	2.25	5.3									
		80	39.8	31.3	2.53	4.6									
	1.8 (4.1)	60	43.6	37.1	1.99	6.4									
		70	42.3	34.8	2.25	5.5									
		80	41.1	32.6	2.54	4.7									
	3.7 (8.6)	60	45.3	38.8	1.99	6.7									
		70	43.9	36.4	2.25	5.7									
		80	42.5	34.0	2.54	4.9									
80	1.0 (2.4)	60	46.8	40.2	1.99	6.9									
		70	45.5	38.0	2.25	5.9									
		80	44.3	35.8	2.55	5.1									
	1.7 (4.0)	60	48.5	42.0	1.99	7.2									
		70	47.1	39.6	2.26	6.1									
		80	45.8	37.3	2.56	5.3									
	3.6 (8.3)	60	50.5	44.0	1.99	7.5									
		70	48.9	41.4	2.26	6.3									
		80	47.4	38.9	2.56	5.4									
100	6	1.0 (2.2)	75/63	28.7	27.0	37.0	2.66	10.8							
			80/67	30.8	28.2	39.2	2.65	11.6							
			85/71	33.1	29.4	41.4	2.63	12.6							
8	1.6 (3.8)	75/63	29.3	27.2	37.4	2.58	11.4								
		80/67	31.5	28.4	39.6	2.56	12.3								
		85/71	33.8	29.6	41.9	2.54	13.3								
12	3.4 (7.8)	75/63	29.9	27.4	37.8	2.49	12.0								
		80/67	32.1	28.7	40.0	2.47	13.0								
		85/71	34.5	29.9	42.3	2.44	14.1								
110	6	1.0 (2.2)	75/63	26.4	26.1	35.8	2.98	8.8							
			80/67	28.4	27.4	37.8	2.97	9.6							
			85/71	30.5	28.5	39.9	2.96	10.3							
	8	1.6 (3.6)	75/63	27.0	26.3	36.1	2.90	9.3							
			80/67	29.1	27.6	38.2	2.88	10.1							
			85/71	31.4	28.7	40.4	2.86	11.0							
	12	3.3 (7.6)	75/63	27.5	26.6	36.3	2.82	9.8							
			80/67	29.8	27.8	38.6	2.79	10.7							
			85/71	32.1	28.9	40.9	2.76	11.6							

Extended Range - Anti-freeze required
 AHR/ISO13256-1 certified performance is rated at entering air conditions of 80.6°F DB and 66.2°F WB in cooling and 68°F DB in heating.
 Tabulated unit performance does not include fan or pump power corrections required for AHR/ISO standard performance ratings.
 Unit performance may be interpolated. Extrapolation is not allowed.
 For conditions other than rating conditions provided, consult the FHP BST selection software.
 Ratings below 40°F are with a methanol solution.
 Due to variations in installation, actual performance may vary from the tabulated data. Performance contained herein are as a result of extensive testing by FHP and are not express warranties between the parties and may be changed at any time.
 Continuous research and development to improve our products may result in a change to the current design and specifications without notice.



Capacity Data

LM048 – Full Load (1600 CFM @ 0.6" ESP)

COOLING									HEATING						
Entering Fluid Temp (°F)	Water Flow (GPM)	Pressure Drop PSI (FOH)	Entering Air Temp (db/wb) °F	Total Capacity (MBTUH)	Sensible Capacity (MBTUH)	Heat of Rejection (MBTUH)	Power Input (kW)	EER	Entering Fluid Temp (°F)	Pressure Drop PSI (FOH)	Entering Air Temp (°F)	Total Capacity (MBTUH)	Heat of Absorption (MBTUH)	Power Input (kW)	COP
50	6	1.1 (2.6)	75/63	52.3	40.1	60.4	2.48	21.1							
			80/67	55.6	41.3	63.9	2.50	22.2							
			85/71	59.2	42.3	67.6	2.53	23.4							
	8	1.9 (4.4)	75/63	53.6	40.6	61.4	2.36	22.7							
			80/67	57.1	41.8	64.9	2.38	24.0							
			85/71	60.8	42.8	68.8	2.40	25.3							
	12	3.9 (9.1)	75/63	54.9	41.3	62.3	2.24	24.5							
			80/67	58.7	42.4	66.2	2.26	26.0							
			85/71	62.5	43.5	70.1	2.27	27.6							
50	6	1.1 (2.5)	75/63	49.9	39.1	58.7	2.69	18.5							
			80/67	53.2	40.3	62.1	2.72	19.6							
			85/71	56.7	41.4	65.7	2.75	20.6							
	8	1.9 (4.3)	75/63	51.2	39.6	59.6	2.57	19.9							
			80/67	54.6	40.9	63.1	2.59	21.1							
			85/71	58.1	42.0	66.7	2.61	22.3							
	12	3.8 (8.8)	75/63	52.5	40.2	60.5	2.46	21.4							
			80/67	56.1	41.3	64.3	2.47	22.7							
			85/71	59.8	42.5	68.0	2.48	24.1							

Extended Range - Anti-freeze required
 AHRI/ISO13256-1 certified performance is rated at entering air conditions of 80.6°F DB and 66.2°F WB in cooling and 68°F DB in heating.
 Tabulated unit performance does not include fan or pump power corrections required for AHRI/ISO standard performance ratings.
 Unit performance may be interpolated. Extrapolation is not allowed.
 For conditions other than rating conditions provided, consult the FHP BST selection software.
 Ratings below 40°F are with a methanol solution.
 Due to variations in installation, actual performance may vary from the tabulated data. Performance contained herein are as a result of extensive testing by FHP and are not express warranties between the parties and may be changed at any time.
 Continuous research and development to improve our products may result in a change to the current design and specifications without notice.



Capacity Data

LM060 – Part Load (1600 CFM @ 0.6" ESP)

COOLING									HEATING						
Entering Fluid Temp (°F)	Water Flow (GPM)	Pressure Drop PSI (FOH)	Entering Air Temp (db/wb) °F	Total Capacity (MBTUH)	Sensible Capacity (MBTUH)	Heat of Rejection (MBTUH)	Power Input (kW)	EER	Entering Fluid Temp (°F)	Pressure Drop PSI (FOH)	Entering Air Temp (°F)	Total Capacity (MBTUH)	Heat of Absorption (MBTUH)	Power Input (kW)	COP
50	7.5	1.2 (2.8)	75/63	51.0	39.6	57.1	1.86	27.4							
			80/67	54.3	40.9	60.3	1.83	29.7							
			85/71	57.8	42.0	63.7	1.80	32.1							
	10	2.0 (4.7)	75/63	52.0	40.1	57.8	1.78	29.2							
			80/67	55.5	41.3	61.2	1.74	31.8							
			85/71	59.2	42.4	64.8	1.71	34.6							
	15	4.2 (9.7)	75/63	53.1	40.6	58.7	1.70	31.3							
			80/67	56.8	41.7	62.3	1.66	34.2							
			85/71	60.4	43.0	65.8	1.62	37.4							
60	7.5	1.1 (2.6)	75/63	48.1	38.5	54.9	2.09	23.0							
			80/67	51.4	39.8	58.2	2.06	24.9							
			85/71	54.9	40.9	61.6	2.03	27.0							
	10	1.9 (4.4)	75/63	49.1	38.9	55.7	2.00	24.5							
			80/67	52.5	40.2	59.0	1.97	26.7							
			85/71	56.0	41.4	62.4	1.93	29.0							
	15	3.9 (9.1)	75/63	50.2	39.3	56.4	1.92	26.2							
			80/67	53.8	40.5	59.9	1.88	28.6							
			85/71	57.4	41.8	63.5	1.84	31.3							
70	7.5	1.1 (2.6)	75/63	45.4	37.2	53.0	2.35	19.3							
			80/67	48.5	38.6	56.0	2.32	20.9							
			85/71	51.7	39.9	59.2	2.29	22.5							
	10	1.9 (4.4)	75/63	46.2	37.7	53.5	2.26	20.4							
			80/67	49.6	38.9	56.8	2.23	22.2							
			85/71	52.9	40.3	60.1	2.19	24.1							
	15	3.9 (9.1)	75/63	47.2	38.1	54.3	2.17	21.7							
			80/67	50.7	39.4	57.6	2.13	23.8							
			85/71	54.1	40.7	60.9	2.09	25.9							
80	7.5	1.1 (2.5)	75/63	42.4	36.1	50.9	2.65	16.0							
			80/67	45.5	37.5	53.9	2.62	17.3							
			85/71	48.6	38.8	57.0	2.59	18.7							
	10	1.8 (4.2)	75/63	43.3	36.5	51.5	2.56	16.9							
			80/67	46.4	37.8	54.5	2.52	18.4							
			85/71	49.7	39.2	57.8	2.49	20.0							
	15	3.8 (8.8)	75/63	44.2	36.8	52.2	2.47	17.9							
			80/67	47.5	38.2	55.3	2.42	19.6							
			85/71	50.9	39.4	58.7	2.38	21.4							
85	7.5	1.1 (2.5)	75/63	41.1	35.5	50.1	2.81	14.6							
			80/67	44.0	36.9	52.9	2.79	15.8							
			85/71	47.0	38.2	55.9	2.76	17.0							
	10	1.8 (4.2)	75/63	41.8	35.9	50.5	2.72	15.4							
			80/67	44.9	37.3	53.5	2.68	16.7							
			85/71	48.0	38.6	56.6	2.65	18.1							
	15	3.7 (8.5)	75/63	42.8	36.2	51.2	2.62	16.3							
			80/67	45.8	37.6	54.2	2.58	17.7							
			85/71	49.1	39.0	57.4	2.54	19.3							
90	7.5	1.0 (2.4)	75/63	39.6	35.0	49.1	2.98	13.3							
			80/67	42.4	36.4	51.9	2.96	14.3							
			85/71	45.4	37.7	54.9	2.93	15.5							
	10	1.8 (4.1)	75/63	40.4	35.3	49.6	2.89	14.0							
			80/67	43.3	36.7	52.5	2.86	15.1							
			85/71	46.4	38.0	55.5	2.82	16.4							
	15	3.7 (8.5)	75/63	41.2	35.6	50.1	2.79	14.7							
			80/67	44.3	36.9	53.2	2.75	16.1							
			85/71	47.4	38.4	56.2	2.71	17.5							
100	7.5	1.0 (2.4)	75/63	36.7	33.8	47.3	3.34	11.0							
			80/67	39.4	35.2	50.0	3.33	11.8							
			85/71	42.3	36.6	52.9	3.30	12.8							
	10	1.7 (4)	75/63	37.4	34.1	47.8	3.25	11.5							
			80/67	40.2	35.5	50.5	3.22	12.5							
			85/71	43.2	36.9	53.5	3.20	13.5							
	15	3.6 (8.3)	75/63	38.1	34.4	48.2	3.16	12.1							
			80/67	41.0	35.8	51.1	3.13	13.1							
			85/71	44.1	37.2	54.0	3.08	14.3							
110	7.5	1.0 (2.3)	75/63	33.8	32.6	45.7	3.74	9.0							
			80/67	36.5	34.2	48.4	3.72	9.8							
			85/71	38.7	35.4	50.6	3.71	10.4							
	10	1.7 (3.9)	75/63	34.5	32.8	46.1	3.65	9.4							
			80/67	37.2	34.4	48.8	3.62	10.3							
			85/71	39.6	35.7	51.2	3.60	11.0							
	15	3.5 (8)	75/63	35.1	33.2	46.4	3.56	9.9							
			80/67	38.0	34.6	49.2	3.53	10.8							
			85/71	40.9	36.1	52.1	3.49	11.7							

Extended Range - Anti-freeze required
 AHR/ISO13256-1 certified performance is rated at entering air conditions of 80.6°F DB and 66.2°F WB in cooling and 68°F DB in heating.
 Tabulated unit performance does not include fan or pump power corrections required for AHR/ISO standard performance ratings.
 Unit performance may be interpolated. Extrapolation is not allowed.
 For conditions other than rating conditions provided, consult the FHP BST selection software.
 Ratings below 40°F are with a methanol solution.
 Due to variations in installation, actual performance may vary from the tabulated data. Performance contained herein are as a result of extensive testing by FHP and are not express warranties between the parties and may be changed at any time.
 Continuous research and development to improve our products may result in a change to the current design and specifications without notice.



Capacity Data

LM060 – Full Load (2000 CFM @ 0.6" ESP)

COOLING									HEATING							
Entering Fluid Temp (°F)	Water Flow (GPM)	Pressure Drop PSI (FOH)	Entering Air Temp (db/wb) °F	Total Capacity (MBTUH)	Sensible Capacity (MBTUH)	Heat of Rejection (MBTUH)	Power Input (kW)	EER	Entering Fluid Temp (°F)	Pressure Drop PSI (FOH)	Entering Air Temp (°F)	Total Capacity (MBTUH)	Heat of Absorption (MBTUH)	Power Input (kW)	COP	
50	7.5	1.2 (2.8)	75/63	66.7	50.5	77.1	3.16	21.1	30	1.3 (3.0)	60	45.9	34.1	3.51	3.8	
			80/67	70.9	52.0	81.5	3.21	22.1			70	45.2	32.1	3.87	3.4	
			85/71	75.3	53.4	86.2	3.27	23.0			80	44.6	30.2	4.25	3.1	
	10	2.0 (4.7)	75/63	68.0	51.2	78.1	3.04	22.3		60	2.2 (5.0)	60	47.4	35.5	3.54	3.9
			80/67	72.6	52.6	82.9	3.10	23.4				70	46.6	33.4	3.90	3.5
			85/71	77.2	53.9	87.7	3.15	24.5				80	45.8	31.3	4.28	3.1
	15	4.2 (9.7)	75/63	69.5	51.8	79.2	2.94	23.7		60	4.5 (10.4)	60	49.1	36.8	3.57	4.0
			80/67	74.0	53.4	84.0	2.98	24.8				70	48.1	34.8	3.93	3.6
			85/71	78.9	54.7	89.0	3.04	26.0				80	47.3	32.7	4.31	3.2
60	7.5	1.1 (2.6)	75/63	63.8	49.4	75.0	3.40	18.8	40	1.3 (2.9)	60	52.0	39.7	3.64	4.2	
			80/67	68.0	50.9	79.4	3.45	19.7			70	51.2	37.7	3.99	3.8	
			85/71	72.4	52.1	84.0	3.51	20.6			80	50.5	35.6	4.38	3.4	
	10	1.9 (4.4)	75/63	65.3	49.8	76.1	3.28	19.9		60	2.1 (4.9)	60	53.9	41.5	3.67	4.3
			80/67	69.6	51.3	80.6	3.32	20.9				70	52.9	39.3	4.03	3.9
			85/71	73.9	52.9	85.1	3.37	21.9				80	52.1	37.1	4.42	3.5
	15	3.9 (9.1)	75/63	66.6	50.5	77.1	3.16	21.1		60	4.4 (10.1)	60	56.0	43.2	3.71	4.4
			80/67	71.0	52.1	81.6	3.20	22.2				70	54.9	40.8	4.07	4.0
			85/71	75.8	53.4	86.6	3.24	23.4				80	53.9	38.8	4.46	3.5
70	7.5	1.1 (2.6)	75/63	61.0	48.2	73.0	3.68	16.6	50	1.2 (2.8)	60	58.8	45.9	3.76	4.6	
			80/67	65.1	49.6	77.4	3.73	17.4			70	57.9	43.6	4.13	4.1	
			85/71	69.0	51.1	81.5	3.78	18.3			80	57.0	41.3	4.53	3.7	
	10	1.9 (4.4)	75/63	62.4	48.6	74.0	3.55	17.6		60	2.0 (4.7)	60	61.1	48.5	3.81	4.7
			80/67	66.4	50.3	78.2	3.59	18.5				70	59.9	45.8	4.17	4.2
			85/71	70.7	51.7	82.7	3.63	19.5				80	58.8	43.4	4.57	3.8
	15	3.9 (9.1)	75/63	63.7	49.2	74.9	3.42	18.6		60	4.2 (9.7)	60	63.6	50.5	3.86	4.8
			80/67	68.0	50.7	79.4	3.46	19.7				70	62.3	48.1	4.22	4.3
			85/71	72.5	52.2	84.1	3.49	20.7				80	61.0	45.4	4.62	3.9
80	7.5	1.1 (2.5)	75/63	58.0	47.0	71.1	4.01	14.5	60	1.2 (2.7)	60	65.9	52.9	3.91	4.9	
			80/67	61.8	48.5	75.1	4.05	15.2			70	64.7	50.3	4.27	4.4	
			85/71	65.7	50.0	79.2	4.10	16.0			80	63.7	48.2	4.69	4.0	
	10	1.8 (4.2)	75/63	59.3	47.5	71.9	3.87	15.3		60	2.0 (4.5)	60	68.8	55.7	3.96	5.1
			80/67	63.4	48.9	76.2	3.90	16.2				70	67.3	52.8	4.33	4.6
			85/71	67.3	50.5	80.3	3.94	17.1				80	66.0	50.0	4.74	4.1
	15	3.8 (8.8)	75/63	60.6	47.9	72.9	3.73	16.2		60	4.1 (9.4)	60	71.8	58.1	4.02	5.2
			80/67	64.7	49.6	77.0	3.76	17.2				70	70.1	55.2	4.39	4.7
			85/71	69.1	50.9	81.6	3.79	18.2				80	68.7	52.4	4.80	4.2
85	7.5	1.1 (2.5)	75/63	56.6	46.2	70.3	4.19	13.5	70	1.1 (2.6)	60	73.5	60.0	4.06	5.3	
			80/67	60.4	47.8	74.3	4.24	14.2			70	72.1	57.2	4.43	4.8	
			85/71	64.1	49.4	78.2	4.28	15.0			80	70.8	54.4	4.86	4.3	
	10	1.8 (4.2)	75/63	57.8	46.8	71.0	4.05	14.3		60	1.9 (4.4)	60	76.8	63.0	4.13	5.5
			80/67	61.6	48.4	75.0	4.08	15.1				70	75.1	60.0	4.50	4.9
			85/71	65.7	49.8	79.3	4.12	16.0				80	73.6	57.0	4.92	4.4
	15	3.7 (8.5)	75/63	59.0	47.2	71.8	3.91	15.1		60	3.9 (9.1)	60	80.4	66.2	4.21	5.6
			80/67	63.0	48.9	75.9	3.93	16.0				70	78.4	62.7	4.58	5.0
			85/71	67.2	50.5	80.2	3.96	17.0				80	76.8	59.4	5.00	4.5
90	7.5	1.0 (2.4)	75/63	55.1	45.6	69.4	4.39	12.5	80	1.1 (2.5)	60	81.5	67.3	4.23	5.7	
			80/67	58.5	47.2	72.9	4.43	13.2			70	79.8	64.3	4.61	5.1	
			85/71	62.3	48.8	77.0	4.48	13.9			80	78.2	61.2	5.04	4.5	
	10	1.8 (4.1)	75/63	56.3	46.1	70.1	4.24	13.3		60	1.8 (4.2)	60	85.2	70.9	4.31	5.8
			80/67	60.1	47.7	74.1	4.27	14.1				70	83.2	67.5	4.69	5.2
			85/71	63.9	49.3	78.1	4.30	14.8				80	81.3	64.1	5.12	4.7
	15	3.7 (8.5)	75/63	57.3	46.7	70.7	4.09	14.0		60	3.8 (8.8)	60	89.3	74.5	4.40	5.9
			80/67	61.4	48.1	74.9	4.12	14.9				70	87.1	71.7	4.79	5.3
			85/71	65.5	49.7	79.1	4.14	15.8				80	84.8	67.3	5.21	4.8
100	7.5	1.0 (2.4)	75/63	51.9	44.5	67.6	4.82	10.8	Extended Range - Anti-freeze required	1.0 (2.3)	60	93.5	78.5	4.20	6.2	
			80/67	55.2	46.0	71.0	4.86	11.4			70	91.5	75.5	4.58	5.6	
			85/71	58.8	47.5	74.8	4.91	12.0			80	89.5	72.5	5.00	5.0	
	10	1.7 (4)	75/63	53.1	44.8	68.3	4.67	11.4		60	1.7 (3.9)	60	97.5	83.5	4.18	6.6
			80/67	56.7	46.5	72.0	4.69	12.1				70	95.5	80.5	4.56	6.0
			85/71	60.3	48.1	75.8	4.73	12.8				80	93.5	77.5	5.00	5.4
	15	3.6 (8.3)	75/63	54.0	45.3	68.7	4.51	12.0		60	1.6 (3.8)	60	101.5	89.5	4.16	7.2
			80/67	57.9	47.0	72.7	4.53	12.8				70	99.5	86.5	4.54	6.6
			85/71	61.8	48.6	76.7	4.56	13.6				80	97.5	83.5	5.00	6.0
110	7.5	1.0 (2.3)	75/63	48.7	43.2	66.0	5.33	9.1	Extended Range - Anti-freeze required	1.0 (2.3)	60	109.5	95.5	4.14	7.8	
			80/67	51.8	44.7	69.3	5.37	9.6			70	107.5	92.5	4.52	7.2	
			85/71	55.3	46.3	73.0	5.41	10.2			80	105.5	89.5	5.00	6.6	
	10	1.7 (3.9)	75/63	49.8	43.5	66.6	5.16	9.6		60	1.6 (3.8)	60	117.5	101.5	4.12	8.4
			80/67	53.2	45.2	70.1	5.19	10.3				70	115.5	98.5	4.50	7.8
			85/71	56.7	46.8	73.7	5.22	10.9				80	113.5	95.5	5.00	7.2
	15	3.5 (8)	75/63	50.8	43.9	67.1	5.01	10.1		60	1.5 (3.7)	60	125.5	107.5	4.10	9.0
			80/67	54.2	45.6	70.6	5.02	10.8				70	123.5	104.5	4.48	8.4
			85/71	57.9	47.2	74.3	5.03	11.5				80	121.5	101.5	5.00	7.8

Extended Range - Anti-freeze required
 AHRI/ISO 13256-1 certified performance is rated at entering air conditions of 80.6°F DB and 66.2°F WB in cooling and 68°F DB in heating.
 Tabulated unit performance does not include fan or pump power corrections required for AHRI/ISO standard performance ratings.
 Unit performance may be interpolated. Extrapolation is not allowed.
 For conditions other than rating conditions provided, consult the FHP BST selection software.
 Ratings below 40°F are with a methanol solution.
 Due to variations in installation, actual performance may vary from the tabulated data. Performance contained herein are as a result of extensive testing by FHP and are not express warranties between the parties and may be changed at any time.
 Continuous research and development to improve our products may result in a change to the current design and specifications without notice.



Capacity Data

LM070 – Part Load (1850 CFM @ 0.6" ESP)

COOLING									HEATING						
Entering Fluid Temp (°F)	Water Flow (GPM)	Pressure Drop PSI (FOH)	Entering Air Temp (db/wb) °F	Total Capacity (MBTUH)	Sensible Capacity (MBTUH)	Heat of Rejection (MBTUH)	Power Input (kW)	EER	Entering Fluid Temp (°F)	Pressure Drop PSI (FOH)	Entering Air Temp (°F)	Total Capacity (MBTUH)	Heat of Absorption (MBTUH)	Power Input (kW)	COP
50	9	0.9 (2.1)	75/63	58.7	45.7	66.2	2.28	25.7	30	1.0 (2.3)	60	39.9	29.3	3.05	3.8
			80/67	62.5	47.1	70.0	2.28	27.4			70	38.9	26.8	3.38	3.4
			85/71	66.4	48.4	73.9	2.27	29.2			80	37.5	24.5	3.76	2.9
	12	1.5 (3.5)	75/63	59.8	46.2	67.0	2.18	27.4		1.6 (3.8)	60	40.0	30.1	3.05	3.8
			80/67	63.9	47.5	71.0	2.17	29.5			70	39.4	28.9	3.39	3.4
			85/71	67.9	48.8	75.1	2.15	31.6			80	38.9	25.9	3.78	3.0
	18	3.2 (7.3)	75/63	61.1	46.6	68.0	2.08	29.4		3.4 (7.9)	60	42.2	30.5	3.06	4.0
			80/67	65.1	48.1	71.9	2.05	31.7			70	40.9	29.6	3.40	3.5
			85/71	69.5	49.3	76.2	2.03	34.3			80	40.0	27.4	3.80	3.1
60	9	0.9 (2)	75/63	55.9	44.6	64.3	2.55	21.9	40	0.9 (2.2)	60	45.2	35.1	3.09	4.3
			80/67	59.6	46.0	68.0	2.55	23.4			70	44.3	32.5	3.44	3.8
			85/71	63.5	47.2	71.9	2.54	24.9			80	43.1	31.7	3.83	3.3
	12	1.5 (3.4)	75/63	57.1	44.9	65.1	2.44	23.4		1.6 (3.7)	60	46.8	36.3	3.10	4.4
			80/67	61.0	46.4	68.9	2.43	25.1			70	44.9	33.0	3.44	3.8
			85/71	64.9	47.7	72.9	2.42	26.8			80	45.1	32.1	3.84	3.4
	18	3.1 (7.1)	75/63	58.2	45.5	65.8	2.33	25.0		3.3 (7.6)	60	45.7	38.3	3.06	4.4
			80/67	62.1	46.9	69.8	2.31	26.9			70	46.8	34.8	3.46	4.0
			85/71	66.2	48.3	73.8	2.29	28.9			80	45.7	32.8	3.85	3.5
70	9	0.9 (2.0)	75/63	53.1	43.4	62.3	2.85	18.6	50	0.9 (2.1)	60	51.4	41.2	3.14	4.8
			80/67	56.7	44.8	66.0	2.85	19.9			70	50.3	38.1	3.48	4.2
			85/71	60.3	46.2	69.6	2.85	21.1			80	49.8	36.6	3.89	3.8
	12	1.4 (3.3)	75/63	54.2	43.8	63.0	2.73	19.8		1.5 (3.5)	60	53.2	42.9	3.15	5.0
			80/67	57.8	45.3	66.7	2.73	21.2			70	52.3	40.7	3.51	4.4
			85/71	61.6	46.7	70.5	2.72	22.6			80	50.8	39.9	3.91	3.8
	18	3.0 (6.9)	75/63	55.3	44.2	63.9	2.62	21.1		3.2 (7.3)	60	55.3	44.8	3.16	5.1
			80/67	59.1	45.7	67.6	2.60	22.7			70	53.8	42.1	3.52	4.5
			85/71	63.1	47.0	71.6	2.59	24.4			80	52.0	38.4	3.91	3.9
80	9	0.8 (1.9)	75/63	50.3	42.1	60.6	3.19	15.8	60	0.9 (2.0)	60	58.2	47.3	3.18	5.4
			80/67	53.7	43.6	64.1	3.19	16.8			70	56.9	44.6	3.55	4.7
			85/71	57.2	45.0	67.7	3.20	17.9			80	55.8	41.9	3.95	4.1
	12	1.4 (3.2)	75/63	51.3	42.5	61.2	3.07	16.7		1.5 (3.4)	60	60.4	49.3	3.19	5.6
			80/67	54.7	44.1	64.7	3.06	17.8			70	58.8	47.0	3.56	4.8
			85/71	58.3	45.5	68.3	3.06	19.0			80	58.8	45.1	3.98	4.3
	18	2.9 (6.6)	75/63	52.3	42.9	61.9	2.95	17.7		3.1 (7.1)	60	63.1	52.0	3.21	5.8
			80/67	55.9	44.5	65.4	2.94	19.0			70	58.1	47.7	3.51	4.9
			85/71	59.6	46.0	69.2	2.92	20.4			80	59.3	45.4	3.99	4.4
85	9	0.8 (1.9)	75/63	48.8	41.5	59.7	3.37	14.5	70	0.9 (2.0)	60	65.3	54.3	3.22	5.9
			80/67	52.1	43.1	63.0	3.38	15.4			70	63.7	51.4	3.61	5.2
			85/71	55.4	44.5	66.4	3.39	16.3			80	62.1	48.8	4.02	4.5
	12	1.3 (3.1)	75/63	49.7	42.0	60.2	3.25	15.3		1.4 (3.3)	60	67.6	57.3	3.24	6.1
			80/67	53.2	43.4	63.8	3.25	16.4			70	66.2	53.6	3.63	5.4
			85/71	56.7	45.0	67.3	3.25	17.4			80	66.0	50.9	4.07	4.8
	18	2.8 (6.5)	75/63	50.7	42.4	60.8	3.13	16.2		3.0 (6.9)	60	70.7	59.3	3.26	6.4
			80/67	54.3	43.9	64.4	3.12	17.4			70	68.9	55.5	3.65	5.5
			85/71	57.9	45.4	68.1	3.11	18.6			80	67.3	53.7	4.09	4.8
90	9	0.8 (1.8)	75/63	47.4	40.9	58.9	3.57	13.3	80	0.8 (1.9)	60	72.6	61.5	3.28	6.5
			80/67	50.6	42.4	62.2	3.58	14.1			70	71	58.2	3.67	5.7
			85/71	53.9	44.0	65.5	3.59	15.0			80	70.6	57.2	4.12	5.0
	12	1.3 (3.1)	75/63	48.2	41.4	59.3	3.45	14.0		1.4 (3.2)	60	75.7	64.2	3.30	6.7
			80/67	51.5	42.9	62.7	3.45	14.9			70	73.7	60.7	3.70	5.8
			85/71	54.9	44.3	66.1	3.45	15.9			80	73.3	59.2	4.15	5.2
	18	2.8 (6.4)	75/63	49.2	41.7	59.9	3.32	14.8		2.9 (6.6)	60	78.9	68.0	3.32	7.0
			80/67	52.7	43.2	63.5	3.31	15.9			70	76.6	64.8	3.73	6.0
			85/71	56.2	44.8	67.0	3.30	17.0			80	70.0	66.5	4.09	5.0
100	9	0.8 (1.8)	75/63	44.2	39.8	57.1	4.01	11.0	Extended Range - Anti-freeze required	1.0 (2.3)	60	39.9	29.3	3.05	3.8
			80/67	47.3	41.3	60.3	4.01	11.8			70	38.9	26.8	3.38	3.4
			85/71	50.5	42.8	63.5	4.03	12.5			80	37.5	24.5	3.76	2.9
	12	1.3 (3)	75/63	45.2	40.0	57.7	3.88	11.6		1.6 (3.8)	60	40.0	30.1	3.05	3.8
			80/67	48.4	41.7	60.9	3.88	12.5			70	39.4	28.9	3.39	3.4
			85/71	51.6	43.2	64.2	3.88	13.3			80	38.9	25.9	3.78	3.0
	18	2.7 (6.2)	75/63	46.0	40.5	58.1	3.75	12.3		3.4 (7.9)	60	42.2	30.5	3.06	4.0
			80/67	49.3	42.0	61.4	3.74	13.2			70	40.9	29.6	3.40	3.5
			85/71	52.8	43.6	64.9	3.73	14.1			80	40.0	27.4	3.80	3.1
110	9	0.7 (1.7)	75/63	41.1	38.4	55.5	4.51	9.1	40	0.9 (2.2)	60	45.2	35.1	3.09	4.3
			80/67	44.1	40.1	58.6	4.50	9.8			70	44.3	32.5	3.44	3.8
			85/71	47.4	41.8	61.9	4.48	10.6			80	43.1	31.7	3.83	3.3
	12	1.3 (2.9)	75/63	41.9	38.8	56.0	4.37	9.6		1.6 (3.7)	60	46.8	36.3	3.10	4.4
			80/67	45.1	40.4	59.2	4.37	10.3			70	44.9	33.0	3.44	3.8
			85/71	48.4	42.1	62.4	4.34	11.1			80	45.1	32.1	3.84	3.4
	18	2.6 (6.1)	75/63	42.8	39.1	56.4	4.24	10.1		3.3 (7.6)	60	45.7	38.3	3.06	4.4
			80/67	45.9	40.8	59.5	4.23	10.9			70	46.8	34.8	3.46	4.0
			85/71	49.3	42.4	62.9	4.20	11.7			80	45.7	32.8	3.85	3.5

Extended Range - Anti-freeze required
 AHR/ISO13256-1 certified performance is rated at entering air conditions of 80.6°F DB and 66.2°F WB in cooling and 68°F DB in heating.
 Tabulated unit performance does not include fan or pump power corrections required for AHR/ISO standard performance ratings.
 Unit performance may be interpolated. Extrapolation is not allowed.
 For conditions other than rating conditions provided, consult the FHP BST selection software.
 Ratings below 40°F are with a methanol solution.
 Due to variations in installation, actual performance may vary from the tabulated data. Performance contained herein are as a result of extensive testing by FHP and are not express warranties between the parties and may be changed at any time.
 Continuous research and development to improve our products may result in a change to the current design and specifications without notice.



Capacity Data

LM070 – Full Load (2350 CFM @ 0.6" ESP)

COOLING									HEATING							
Entering Fluid Temp (°F)	Water Flow (GPM)	Pressure Drop PSI (FOH)	Entering Air Temp (db/wb) °F	Total Capacity (MBTUH)	Sensible Capacity (MBTUH)	Heat of Rejection (MBTUH)	Power Input (kW)	EER	Entering Fluid Temp (°F)	Pressure Drop PSI (FOH)	Entering Air Temp (°F)	Total Capacity (MBTUH)	Heat of Absorption (MBTUH)	Power Input (kW)	COP	
50	9	0.9 (2.1)	75/63	74.7	56.2	86.9	3.69	20.2	30	1.0 (2.3)	60	52.6	38.2	4.16	3.7	
			80/67	79.4	58.1	91.8	3.74	21.2			70	51.6	35.9	4.56	3.3	
			85/71	84.4	59.7	97.0	3.79	22.2			80	51.1	34.0	4.99	3.0	
	12	1.5 (3.5)	75/63	76.3	56.9	88.1	3.54	21.6		60	1.6 (3.8)	60	54.0	39.6	4.19	3.8
			80/67	81.4	58.5	93.3	3.59	22.7				70	53.2	37.6	4.59	3.4
			85/71	86.5	60.5	98.6	3.63	23.9				80	52.8	35.7	5.03	3.1
	18	3.2 (7.3)	75/63	78.1	57.6	89.3	3.38	23.1		60	3.4 (7.9)	60	55.8	41.8	4.24	3.9
			80/67	83.4	59.3	94.8	3.42	24.4				70	55.4	40.3	4.64	3.5
			85/71	88.9	60.9	100.5	3.46	25.7				80	54.5	37.2	5.07	3.2
60	9	0.9 (2)	75/63	71.6	54.8	84.7	3.99	18.0	40	0.9 (2.2)	60	59.3	44.5	4.29	4.0	
			80/67	76.1	56.8	89.4	4.03	18.9			70	58.5	42.3	4.70	3.7	
			85/71	81.1	58.2	94.6	4.08	19.9			80	57.9	40.1	5.14	3.3	
	12	1.5 (3.4)	75/63	73.2	55.5	85.8	3.83	19.1		60	1.6 (3.7)	60	61.7	46.6	4.33	4.2
			80/67	78.1	57.2	90.9	3.87	20.2				70	60.8	44.6	4.74	3.8
			85/71	83.2	58.8	96.2	3.91	21.3				80	60.2	42.0	5.19	3.4
	18	3.1 (7.1)	75/63	74.9	56.3	87.0	3.67	20.4		60	3.3 (7.6)	60	64.3	49.3	4.38	4.3
			80/67	79.8	58.3	92.1	3.70	21.5				70	63.1	47.1	4.79	3.9
			85/71	85.1	60.0	97.6	3.73	22.8				80	62.4	43.4	5.23	3.5
70	9	0.9 (2.0)	75/63	68.4	53.4	82.5	4.32	15.8	50	0.9 (2.1)	60	67.3	52.1	4.44	4.4	
			80/67	72.7	55.5	87.1	4.36	16.7			70	66.4	49.9	4.85	4.0	
			85/71	77.4	57.0	92.0	4.41	17.6			80	65.3	46.9	5.31	3.6	
	12	1.4 (3.3)	75/63	69.8	54.4	83.4	4.15	16.8		60	1.5 (3.5)	60	69.9	54.4	4.48	4.6
			80/67	74.4	56.2	88.3	4.19	17.7				70	68.7	51.8	4.90	4.1
			85/71	79.3	58.0	93.2	4.22	18.8				80	67.7	49.1	5.36	3.7
	18	3.0 (6.9)	75/63	71.5	54.8	84.7	3.99	17.9		60	3.2 (7.3)	60	73.2	58.0	4.55	4.7
			80/67	76.3	56.9	89.5	4.02	19.0				70	71.9	54.7	4.96	4.2
			85/71	81.6	58.2	95.0	4.05	20.1				80	70.2	51.5	5.42	3.8
80	9	0.8 (1.9)	75/63	64.9	52.3	80.2	4.69	13.8	60	0.9 (2.0)	60	75.7	59.7	4.59	4.8	
			80/67	69.2	54.0	84.8	4.74	14.6			70	74.6	57.1	5.01	4.4	
			85/71	73.8	55.5	89.5	4.78	15.4			80	73.6	54.6	5.49	3.9	
	12	1.4 (3.2)	75/63	66.5	52.7	81.3	4.52	14.7		60	1.5 (3.4)	60	78.8	62.8	4.65	5.0
			80/67	70.8	54.8	85.8	4.55	15.5				70	77.4	59.8	5.08	4.5
			85/71	75.3	57.1	90.4	4.58	16.4				80	76.1	56.8	5.55	4.0
	18	2.9 (6.6)	75/63	68.0	53.3	82.3	4.35	15.6		60	3.1 (7.1)	60	82.7	66.8	4.73	5.1
			80/67	72.6	55.4	87.0	4.38	16.6				70	79.0	61.1	5.12	4.5
			85/71	77.5	57.1	92.0	4.40	17.6				80	79.5	60.1	5.62	4.1
85	9	0.8 (1.9)	75/63	63.3	51.6	79.3	4.88	13.0	70	0.9 (2.0)	60	84.2	67.8	4.75	5.2	
			80/67	67.4	53.5	83.6	4.93	13.7			70	82.6	64.7	5.19	4.7	
			85/71	71.7	55.2	88.1	4.98	14.4			80	81.4	61.8	5.67	4.2	
	12	1.3 (3.1)	75/63	64.8	51.9	80.2	4.72	13.7		60	1.4 (3.3)	60	88.6	72.2	4.84	5.4
			80/67	69.0	54.1	84.6	4.75	14.5				70	86.9	69.2	5.27	4.8
			85/71	73.6	55.6	89.4	4.78	15.4				80	84.8	64.9	5.74	4.3
	18	2.8 (6.5)	75/63	66.2	52.5	81.2	4.55	14.5		60	3.0 (6.9)	60	92.8	75.8	4.92	5.5
			80/67	70.8	54.3	85.9	4.58	15.5				70	90.9	72.2	5.36	5.0
			85/71	75.4	56.6	90.5	4.59	16.4				80	88.6	68.8	5.83	4.5
90	9	0.8 (1.8)	75/63	61.6	51.0	78.3	5.09	12.1	80	0.8 (1.9)	60	93.3	76.4	4.93	5.5	
			80/67	65.7	52.8	82.6	5.14	12.8			70	91.6	73.1	5.37	5.0	
			85/71	69.9	54.5	86.9	5.18	13.5			80	90.0	69.7	5.86	4.5	
	12	1.3 (3.1)	75/63	63.0	51.6	79.1	4.92	12.8		60	1.4 (3.2)	60	97.9	80.6	5.03	5.7
			80/67	67.2	53.4	83.5	4.96	13.6				70	95.8	77.0	5.46	5.1
			85/71	71.5	55.4	87.9	4.99	14.3				80	94.5	74.0	5.96	4.6
	18	2.8 (6.4)	75/63	64.4	51.9	79.9	4.76	13.5		60	2.9 (6.6)	60	103.2	85.5	5.13	5.9
			80/67	68.8	54.0	84.5	4.78	14.4				70	100.7	81.4	5.57	5.3
			85/71	73.5	55.5	89.4	4.80	15.3				80	98.2	77.3	6.05	4.8
100	9	0.8 (1.8)	75/63	58.3	49.6	76.4	5.55	10.5	Extended Range - Anti-freeze required	0.8 (1.8)	60	100.7	81.4	5.57	5.3	
			80/67	62.2	51.5	80.5	5.60	11.1			70	98.2	77.3	6.05	4.8	
			85/71	66.1	53.2	84.7	5.64	11.7			80	96.7	74.4	6.54	4.3	
	12	1.3 (3)	75/63	59.5	50.2	77.1	5.37	11.1		60	1.3 (3)	60	103.2	85.5	5.13	5.9
			80/67	63.6	52.0	81.3	5.41	11.8				70	101.7	81.4	5.57	5.3
			85/71	67.8	53.7	85.6	5.44	12.5				80	100.2	78.5	6.05	4.8
	18	2.7 (6.2)	75/63	60.9	50.5	77.9	5.20	11.7		60	2.7 (6.2)	60	106.7	88.6	5.27	6.1
			80/67	65.1	52.4	82.3	5.22	12.5				70	105.2	84.7	5.74	5.6
			85/71	69.5	54.2	86.7	5.25	13.2				80	103.7	80.8	6.21	5.1
110	9	0.7 (1.7)	75/63	54.9	48.1	74.8	6.10	9.0	Extended Range - Anti-freeze required	0.7 (1.7)	60	106.7	88.6	5.27	6.1	
			80/67	58.4	50.1	78.5	6.14	9.5			70	105.2	84.7	5.74	5.6	
			85/71	64.9	52.2	83.3	6.21	10.4			80	103.7	80.8	6.21	5.1	
	12	1.3 (2.9)	75/63	56.1	48.6	75.3	5.90	9.5		60	1.3 (2.9)	60	110.7	91.4	5.40	6.4
			80/67	60.0	50.1	79.4	5.93	10.1				70	109.2	87.5	5.87	5.9
			85/71	64.6	51.1	84.2	5.97	10.8				80	107.7	83.6	6.34	5.4
	18	2.6 (6.1)	75/63	57.1	49.5	75.7	5.71	10.0		60	2.6 (6.1)	60	115.7	98.6	5.50	6.7
			80/67	61.3	50.9	80.1	5.74	10.7				70	114.2	94.7	5.97	6.2
			85/71	65.3	53.0	84.1	5.75	11.3				80	112.7	90.8	6.44	5.7

Extended Range - Anti-freeze required
 AHRI/ISO 13256-1 certified performance is rated at entering air conditions of 80.6°F DB and 66.2°F WB in cooling and 68°F DB in heating.
 Tabulated unit performance does not include fan or pump power corrections required for AHRI/ISO standard performance ratings.
 Unit performance may be interpolated. Extrapolation is not allowed.
 For conditions other than rating conditions provided, consult the FHP BST selection software.
 Ratings below 40°F are with a methanol solution.
 Due to variations in installation, actual performance may vary from the tabulated data. Performance contained herein are as a result of extensive testing by FHP and are not express warranties between the parties and may be changed at any time.
 Continuous research and development to improve our products may result in a change to the current design and specifications without notice.



Water Pressure Drop mixture of 15% methonal / water solution.

Model	Water Flow Rate (GPM)	Water Side Pressure Drop without Internal Valve (PSI)	Water Side Pressure Drop with Internal Valve (PSI)	Water Side Pressure Drop without Internal Valve (FOH)	Water Side Pressure Drop with Internal Valve (FOH)
LM024	3	0.7	2.1	1.59	4.92
	4	1.2	3.7	2.67	8.58
	5	1.7	5.7	3.99	13.23
	6	2.4	8.2	5.54	18.85
	7	3.2	11.0	7.31	25.42
LM036	8	4.0	14.3	9.30	32.95
	4.5	1.3	2.1	2.98	4.85
	6	2.2	3.6	5.01	8.33
	7.5	3.2	5.5	7.48	12.68
	9	4.5	7.7	10.39	17.87
LM048	10.5	5.9	10.3	13.71	23.89
	12	7.5	13.3	17.43	30.74
	6	1.1	2.5	2.46	5.78
	8	1.8	4.3	4.12	10.03
	10	2.7	6.7	6.16	15.40
LM060	12	3.7	9.5	8.55	21.86
	14	4.9	12.7	11.28	29.40
	16	6.2	16.5	14.35	38.01
	7.5	1.1	2.1	2.61	4.92
	10	1.9	3.7	4.39	8.49
LM070	12.5	2.8	5.6	6.56	12.97
	15	3.9	7.9	9.10	18.34
	17.5	5.2	10.6	12.01	24.59
	20	6.6	13.7	15.28	31.70
	9	0.9	2.3	1.97	5.29
LM070	12	1.4	4.0	3.30	9.21
	15	2.1	6.1	4.93	14.17
	18	3.0	8.7	6.84	20.15
	21	3.9	11.7	9.03	27.14
	24	5.0	15.2	11.49	35.14

NOTE: Based on 77 deg

Antifreeze Correction Data

Antifreeze Type	Antifreeze % volume	Cooling			Heating		WPD Correction Factor EWT 30 ° F
		EWT 90 ° F			EWT 30 ° F		
		Total Cap.	Sens. Cap	Power	Htg. Cap	Power	
Propylene Glycol	0	1.000	1.000	1.000	1.000	1.000	1.000
	5	0.997	0.997	1.004	0.989	0.997	1.060
	10	0.994	0.994	1.006	0.986	0.995	1.125
	15	0.990	0.990	1.009	0.978	0.988	1.190
	25	0.983	0.983	1.016	0.960	0.979	1.300
Methanol	5	0.997	0.997	1.003	0.990	0.997	1.060
	10	0.996	0.996	1.005	0.979	0.993	1.100
	15	0.994	0.994	1.008	0.970	0.990	1.140
Ethanol	5	0.998	0.998	1.002	0.981	0.994	1.160
	10	0.996	0.996	1.004	0.960	0.988	1.230
	15	0.992	0.992	1.006	0.944	0.983	1.280
	25	0.986	0.986	1.009	0.917	0.974	1.400
Ethylene Glycol	5	0.997	0.997	1.003	0.993	0.998	1.060
	10	0.995	0.995	1.004	0.986	0.996	1.120
	15	0.992	0.992	1.005	0.980	0.993	1.190
	25	0.988	0.988	1.009	0.970	0.990	1.330
	30	0.985	0.985	1.012	0.965	0.987	1.400

Subject to change without prior notice.

Electrical Data

Constant Torque and Constant CFM ECM

Model	Voltage Code	Rated Voltage	Voltage Min/Max	Compressor			Total Unit ECM Const Torque motor (Standard)			Total Unit ECM Const Air Flow motor (Option)		
				Quantity	RLA	LRA	FLA	Min Circuit Amps	Max Fuse/HACR	FLA	Min Circuit Amps	Max Fuse/HACR
LM024	1	208-230/1/60	197/253	1	11.7	58.3	2.8	17.4	25	2.8	17.4	25
	2	265-277/1/60	238-292	1	9.1	54.0	2.6	14.0	20	2.6	14.0	20
	3	208-230/3/60	197/253	1	6.5	55.4	2.8	10.9	15	2.8	10.9	15
	4	460/3/60	414/506	1	3.5	28.0	2.1	6.4	15	2.6	6.9	15
LM036	1	208-230/1/60	197/253	1	15.3	83.0	2.8	25.1	35	6.8	25.9	35
	2	265-277/1/60	238-292	1	13.0	72.0	2.6	21.2	30	5.5	21.8	35
	3	208-230/3/60	197/253	1	11.6	73.0	2.8	20.5	30	6.8	21.3	30
	4	460/3/60	414/506	1	5.7	38.0	2.1	10.4	15	5.5	12.6	15
LM048	1	208-230/1/60	197/253	1	21.2	104.0	2.8	32.4	50	6.8	33.2	50
	3	208-230/3/60	197/253	1	14.0	83.1	2.6	23.5	35	6.8	24.3	35
	4	460/3/60	414/506	1	6.4	41.0	2.8	11.3	15	5.5	13.5	15
LM060	1	208-230/1/60	197/253	1	27.1	152.9	4.1	41.5	60	9.1	43.0	70
	3	208-230/3/60	197/253	1	16.5	110.0	3.9	28.3	40	9.1	29.8	45
	4	460/3/60	414/506	1	7.2	52.0	4.1	13.1	20	6.9	16.0	20
LM070	1	208-230/1/60	197/253	1	29.7	179.2	6.0	44.7	70	9.1	46.2	70
	3	208-230/3/60	197/253	1	17.6	136.0	6.0	29.6	45	9.1	31.1	45
	4	460/3/60	414/506	1	8.5	66.1	4.6	14.6	20	6.9	17.5	25

For units with Factory Installed Electric Heat Option, the unit will have two separate electrical connections. There will be two separate data tags; one for each electrical circuit. The 1st data tag is for the compressor power connection, the second is for the fan motor and electric heat strips.

Model	Voltage Code	Voltage/Phase/Hz	Voltage Min/Max	Compressor			Compressor Electrical Sizing	
				Quantity	RLA	LRA	Min Circuit Amps	Max Fuse/HACR
LM024	1	208-230/1/60	197/253	1	11.7	58.3	14.6	25
LM036	1	208-230/1/60	197/253	1	15.3	83.0	19.1	30
LM048	1	208-230/1/60	197/253	1	21.2	104.0	26.5	45
LM060	1	208-230/1/60	197/253	1	27.1	152.9	33.9	60
LM070	1	208-230/1/60	197/253	1	29.7	179.2	37.1	60

Electrical Data

For Units with EH Option – Constant Torque ECM

Model	EH Rated kW	Stage	Heater Watts		Heater AMPS			Circuit Fuses	MCA		MOP	
			240	208	240V	280V	Motor FLA (A)		240V	208V	240V	208V
LM024	4.8	1	4,800	3,600	20.0	17.3	2.8	-	28.5	25.1	30	30
LM036	4.8	1	4,800	3,600	20.0	17.3	6.0	-	32.5	29.1	35	30
LM036	9.6	1	9,600	7,200	40.0	34.6	6.0	-	57.5	50.8	60	60
LM048	4.8	1	4,800	3,600	20.0	17.3	6.0	-	32.5	29.1	35	30
LM048	9.6	1	9,600	7,200	40.0	34.6	6.0	-	57.5	50.8	60	60
LM048	14.4	2	14400	10800	60	51.9	6	F1/F2 F3/F4	82.5	72.4	90	80
LM060	4.8	1	4,800	3,600	20.0	17.3	7.6	-	34.5	31.1	35	35
LM060	9.6	1	9,600	7,200	40.0	34.6	7.6	-	59.5	52.8	60	60
LM060	14.4	2	14400	10800	60	51.9	7.6	F1/F2 F3/F4	84.5	74.4	90	80
LM060	19.2	2	19200	14000	80	69.2	7.6	F1/F2 F3/F4	109.5	96.0	110	100
LM070	4.8	1	4,800	3,600	20.0	17.3	7.6	-	34.5	31.1	35	35
LM070	9.6	1	9,600	7,200	40.0	34.6	7.6	-	59.5	52.8	60	60
LM070	14.4	2	14400	10800	60	51.9	7.6	F1/F2 F3/F4	84.5	74.4	90	80
LM070	19.2	2	19200	14000	80	69.2	7.6	F1/F2 F3/F4	109.5	96.0	110	100

* PLEASE NOTE: Electric heat is not available for horizontal-straight through airflow configuration. Use a Bosch flanged duct heater in this application.

For Units with EH Option – Constant CFM ECM

Model	EH Rated kW	Stage	Heater Watts		Heater AMPS			Circuit Fuses	MCA		MOP	
			240	208	240V	280V	Motor FLA (A)		240V	208V	240V	208V
LM024	4.8	1	4,800	3,600	20.0	17.3	2.8	-	28.5	25.1	30	30
LM036	4.8	1	4,800	3,600	20.0	17.3	6.8	-	33.5	30.1	35	35
LM036	9.6	1	9,600	7,200	40.0	34.6	6.8	-	58.5	51.8	60	60
LM048	4.8	1	4,800	3,600	20.0	17.3	6.8	-	33.5	30.1	35	35
LM048	9.6	1	9,600	7,200	40.0	34.6	6.8	-	58.5	51.8	60	60
LM048	14.4	2	14400	10800	60	51.9	6.8	F1/F2 F3/F4	83.5	73.4	90	80
LM060	4.8	1	4,800	3,600	20.0	17.3	9.1	-	36.4	33.0	40	35
LM060	9.6	1	9,600	7,200	40.0	34.6	9.1	-	61.4	54.6	70	60
LM060	14.4	2	14400	10800	60	51.9	9.1	F1/F2 F3/F4	86.4	76.3	90	80
LM060	19.2	2	19200	14000	80	69.2	9.1	F1/F2 F3/F4	111.4	97.9	125	100
LM070	4.8	1	4,800	3,600	20.0	17.3	9.1	-	36.4	33.0	40	35
LM070	9.6	1	9,600	7,200	40.0	34.6	9.1	-	61.4	54.6	70	60
LM070	14.4	2	14400	10800	60	51.9	9.1	F1/F2 F3/F4	86.4	76.3	90	80
LM070	19.2	2	19200	14000	80	69.2	9.1	F1/F2 F3/F4	111.4	97.9	125	100

* PLEASE NOTE: Electric heat is not available for horizontal-straight through airflow configuration. Use a Bosch flanged duct heater in this application.

Blower Performance

ECM Constant Torque

Model	External Static Pressure (in of Water)														
	Motor Speed	Rated Airflow	Factory Setting	0.10	0.20	0.30	0.40	0.50	0.60	0.70	0.80	0.90	1.00	1.10	1.20
LM024	5	950		1154	1117	1077	1034	988	938	886	830	-	-	-	-
	4	825	Full Load	1072	1018	966	915	866	818	772	727	-	-	-	-
	3	725		976	920	867	815	766	719	674	631	-	-	-	-
	2	650	Part Load/ Fan Only	906	844	785	730	678	630	585	544	-	-	-	-
	1	500		829	750	676	610	551	498	451	412	-	-	-	-
LM036	5	1300		1506	1469	1430	1390	1347	1300	1249	1193	1130	1061	-	-
	4	1100	Full Load	1425	1326	1250	1190	1142	1100	1056	1005	942	860	-	-
	3	950		1354	1233	1138	1063	1002	950	901	850	791	719	-	-
	2	800	Part Load/ Fan Only	1294	1157	1041	946	866	800	744	696	653	611	-	-
	1	750		1213	1084	976	886	812	750	698	653	612	573		
LM048	5	1800		1950	1911	1880	1852	1826	1800	1770	1736	1695	1644	-	-
	4	1600	Full Load	1774	1737	1703	1669	1635	1599	1562	1520	1474	1422	-	-
	3	1400		1565	1526	1493	1462	1432	1400	1363	1318	1265	1199	-	-
	2	1300	Part Load/ Fan Only	1506	1468	1430	1389	1346	1300	1249	1192	1130	1061	-	-
	1	1100		1425	1326	1250	1190	1142	1100	1056	1005	942	860	-	-
LM060	5	2200		2475	2402	2338	2283	2237	2199	2171	2152	2142	2141	2148	2165
	4	2000	Full Load	2169	2134	2099	2065	2032	2000	1968	1936	1906	1876	1847	1819
	3	1800		1942	1914	1886	1857	1829	1799	1770	1740	1710	1679	1648	1617
	2	1600	Part Load/ Fan Only	1766	1728.6	1693	1660	1629	1600	1573	1548	1525	1505	1486	1470
	1	1400		1561	1520	1483	1451	1423	1399	1380	1366	1356	1350	1348	1351
LM070	5	2500		2723	2670	2622	2577	2537	2500	2466	2437	2411	2390	2372	2357
	4	2350	Full Load	2565	2528	2488	2445	2399	2349	2297	2242	2183	2122	2057	1989
	3	2100		2255	2230	2202	2171	2137	2100	2060	2017	1971	1922	1870	1815
	2	1850	Part Load/ Fan Only	2003	1975	1945	1914	1882	1850	1816	1781	1744	1707	1669	1629
	1	1600		1765	1728	1693	1660	1629	1600	1573	1548	1525	1505	1486	1470

Blower Performance

ECM Constant CFM

Model	External Static Pressure (in of Water)													
	Motor Speed	Rated Airflow	Adjust	Tap	0.10	0.20	0.30	0.40	0.50	0.60	0.70	0.80	0.90	1.00
LM024 Part Load	Low	725	+	A	725	725	725	725	725	725	725	725	-	-
	Medium	650	Normal	A	650	650	650	650	650	650	650	650	-	-
	High	500	-	A	500	500	500	500	500	500	500	500	-	-
LM024 Full Load	Low	950	+	A	950	950	950	950	950	950	950	950	-	-
	Medium	825	Normal	A	825	825	825	825	825	825	825	825	-	-
	High	725	-	A	725	725	725	725	725	725	725	725	-	-
LM036 Part Load	Low	950	+	A	950	950	950	950	950	950	950	950	950	950
	Medium	800	Normal	A	800	800	800	800	800	800	800	800	800	800
	High	750	-	A	750	750	750	750	750	750	750	750	750	750
LM036 Full Load	Low	1300	+	A	1300	1300	1300	1300	1300	1300	1300	1300	1300	1300
	Medium	1100	Normal	A	1100	1100	1100	1100	1100	1100	1100	1100	1100	1100
	High	950	-	A	950	950	950	950	950	950	950	950	950	950
LM048 Part Load	Low	1400	+	A	1400	1400	1400	1400	1400	1400	1400	1400	1400	1400
	Medium	1300	Normal	A	1300	1300	1300	1300	1300	1300	1300	1300	1300	1300
	High	1100	-	A	1100	1100	1100	1100	1100	1100	1100	1100	1100	1100
LM048 Full Load	Low	1800	+	A	1800	1800	1800	1800	1800	1800	1800	1800	1800	1800
	Medium	1600	Normal	A	1600	1600	1600	1600	1600	1600	1600	1600	1600	1600
	High	1400	-	A	1400	1400	1400	1400	1400	1400	1400	1400	1400	1400
LM060 Part Load	Low	1800	+	A	1800	1800	1800	1800	1800	1800	1800	1800	1800	1800
	Medium	1600	Normal	A	1600	1600	1600	1600	1600	1600	1600	1600	1600	1600
	High	1400	-	A	1400	1400	1400	1400	1400	1400	1400	1400	1400	1400
LM060 Full Load	Low	2200	+	A	2200	2200	2200	2200	2200	2200	2200	2200	2200	2200
	Medium	2000	Normal	A	2000	2000	2000	2000	2000	2000	2000	2000	2000	2000
	High	1800	-	A	1800	1800	1800	1800	1800	1800	1800	1800	1800	1800
LM070 Part Load	Low	2100	+	A	2100	2100	2100	2100	2100	2100	2100	2100	2100	2100
	Medium	1850	Normal	A	1850	1850	1850	1850	1850	1850	1850	1850	1850	1850
	High	1600	-	A	1600	1600	1600	1600	1600	1600	1600	1600	1600	1600
LM070 Full Load	Low	2500	+	A	2500	2500	2500	2500	2500	2500	2500	2500	2500	2500
	Medium	2350	Normal	A	2350	2350	2350	2350	2350	2350	2350	2350	2350	2350
	High	2100	-	A	2100	2100	2100	2100	2100	2100	2100	2100	2100	2100

Vertical Unit Dimensions

Vertical Top Discharge Water Source Heat Pump

Model	A		B		C		D		E		F		G		H		J		K		L		M		N		P		T		U		V		W		WATER CONNECTIONS	FILTER SIZE			
	WIDTH	DEPTH	HEIGHT	DEPTH	WIDTH	HEIGHT	RETURN AIR DUCT HEIGHT	WIDTH	DEPTH	WIDTH	HEIGHT	WATER OUT	DRAIN PORT	WATER IN	ELECTRICAL KNOCKOUT	HEATER KNOCKOUT	LH	RH	LH	RH	LH	RH	LH	RH	LH	RH	LH	RH	LH	RH	LH	RH	LH	RH							
LM024-VT	24.0	27.4	44.4	24.5	24.9	22.4	22.3	3.3	24.5	3.3	12.1	5.8	3.1	11.7	8.1	5.7	8.7	8.7	10	10	1.9	8	10.8	10.8	10.8	10.8	10.8	10.8	10.8	10.8	10.8	10.8	10.8	10.8	10.8	10.8	10.8	10.8	3/4" F.P.T	24X24X2 (1)	
LM036-VT	25.8	33.4	52.4	30.5	32.9	30.6	28.4	3.3	30.5	3.3	14.9	5.8	3.1	11.7	8.1	5.7	10.8	10.8	11.7	11.7	1.9	8.9	13	13	13	13	13	13	13	13	13	13	13	13	13	13	13	13	13	1"	16X30X2 (2)
LM048-VT	25.8	33.4	52.4	30.5	32.9	30.6	28.4	3.3	30.5	3.3	14.9	5.8	3.1	11.7	8.1	5.7	10.8	10.8	11.7	11.7	1.9	8.9	13	13	13	13	13	13	13	13	13	13	13	13	13	13	13	13	1"	16X30X2 (2)	
LM060-VT	27.0	33.4	61.8	30.5	41.0	38.7	28.4	3.3	30.5	3.3	14.9	5.8	3.1	11.7	8.1	5.7	9.6	9.6	14.1	14.1	1.9	8.9	14.1	14.1	14.1	14.1	14.1	14.1	14.1	14.1	14.1	14.1	14.1	14.1	14.1	14.1	14.1	14.1	1"	20X30X2 (2)	
LM070-VT	27.0	33.4	61.8	30.5	41.0	38.7	28.4	3.3	30.5	3.3	14.9	5.8	3.1	11.7	8.1	5.7	9.6	9.6	14.1	14.1	1.9	8.9	14.1	14.1	14.1	14.1	14.1	14.1	14.1	14.1	14.1	14.1	14.1	14.1	14.1	14.1	14.1	14.1	1"	20X30X2 (2)	

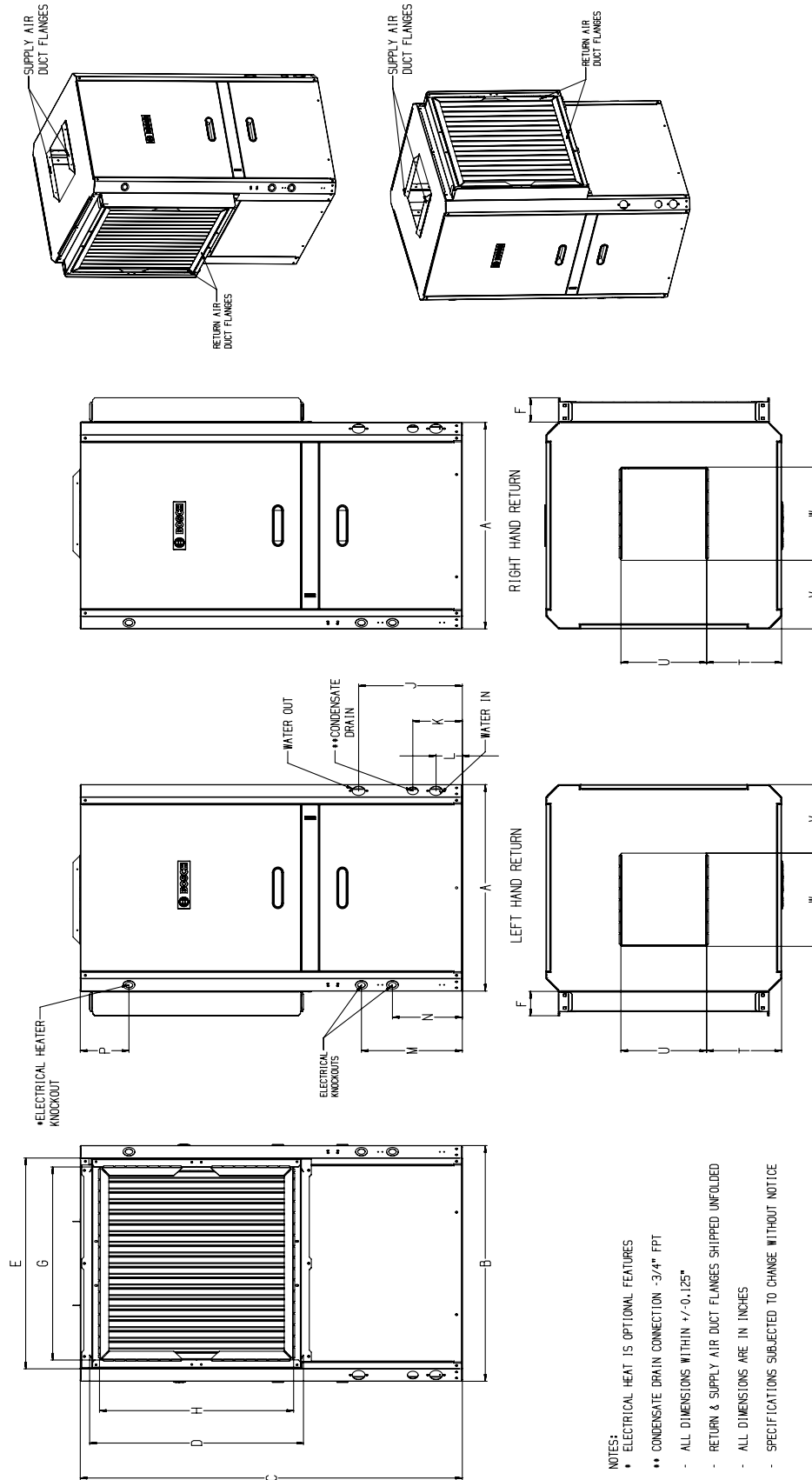

- NOTES:
- ELECTRICAL HEAT IS OPTIONAL FEATURE
 - CONDENSATE DRAIN CONNECTION -3/4" FPT
 - ALL DIMENSIONS WITHIN +/-0.125"
 - RETURN & SUPPLY AIR DUCT FLANGES SHIPPED UNFOLDED
 - ALL DIMENSIONS ARE IN INCHES
 - SPECIFICATIONS SUBJECT TO CHANGE WITHOUT NOTICE

Vertical Unit Dimensions

LM024 – Vertical Top Discharge Water Source Heat Pump

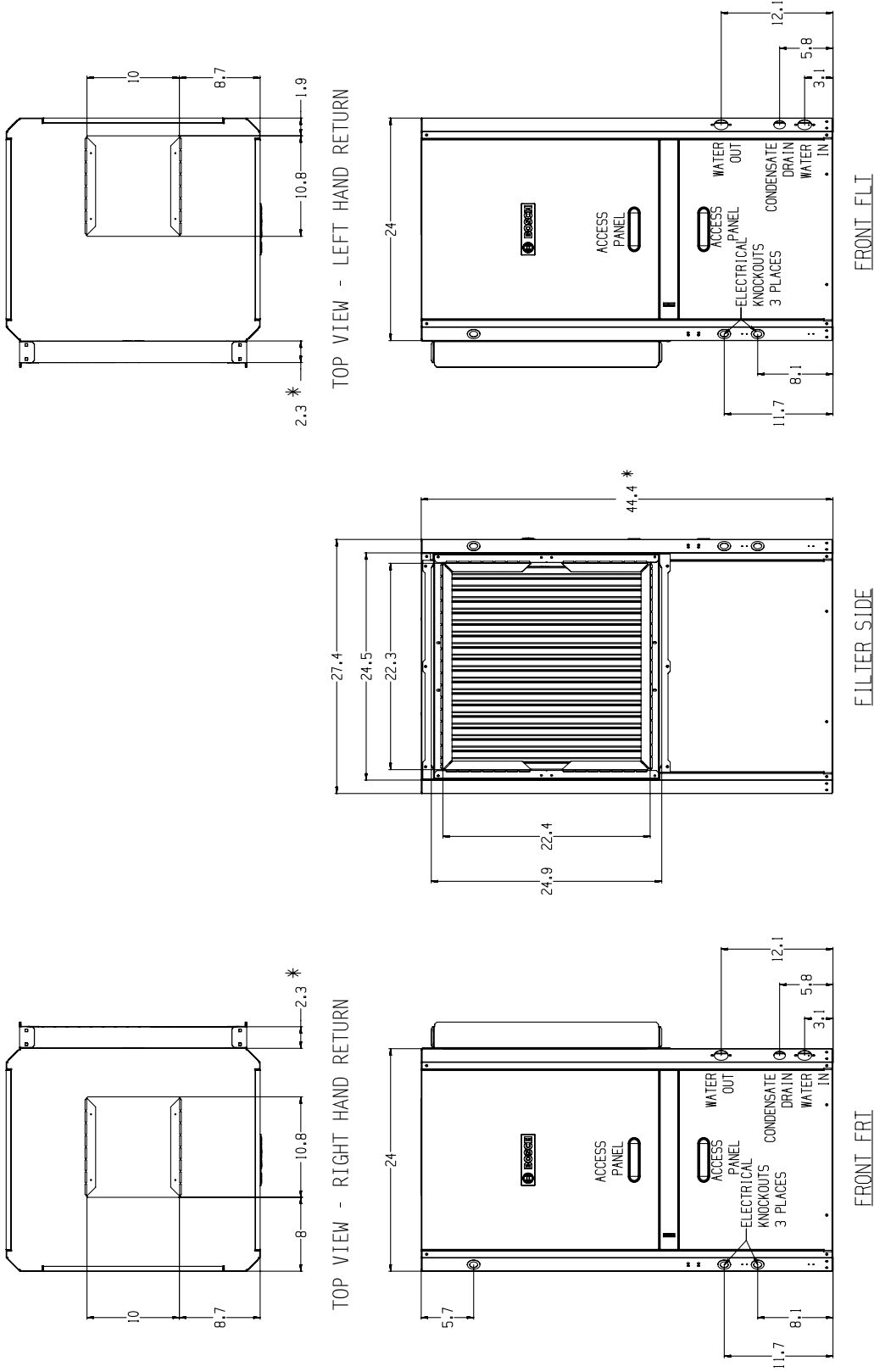

LM-024 RIGHT & LEFT HAND VERTICAL CERTIFIED DRAWING
 ROBERT BOSCH LLC RESERVES THE RIGHT TO MAKE CONTINUOUS IMPROVEMENTS THAT MAY AFFECT THE DIMENSIONS SHOWN

NOTE:
 * ADD .1" FOR DUCT COLLAR/RETURN AIR DUCT FLANGE SHOWN UNBENT

Vertical Unit Dimensions

LM036/048 – Vertical Top Discharge Water Source Heat Pump

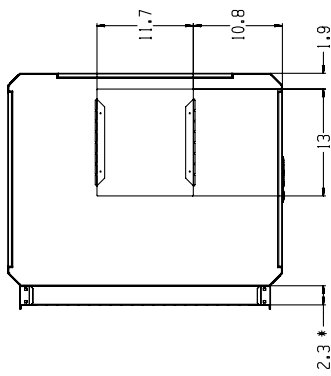

TOP VIEW - LEFT HAND RETURN

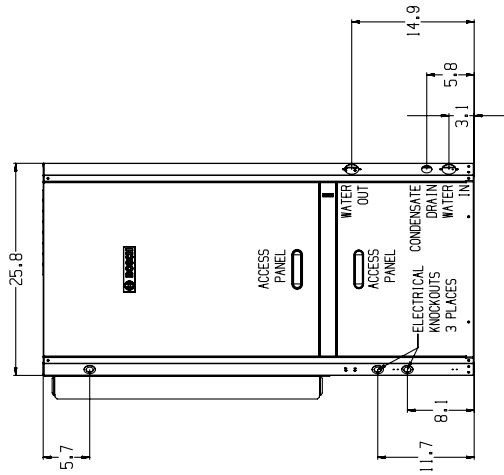

FRONT FLT

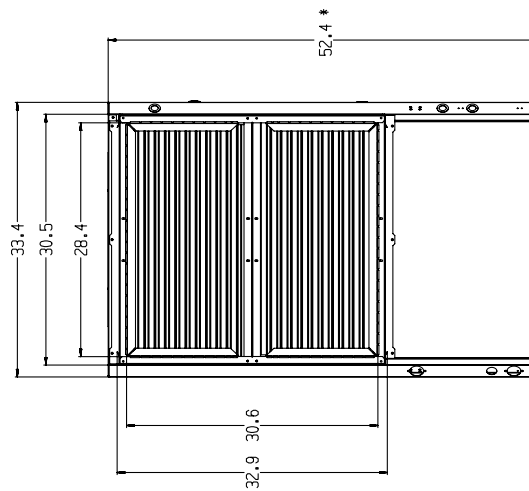

ELLER SIDE

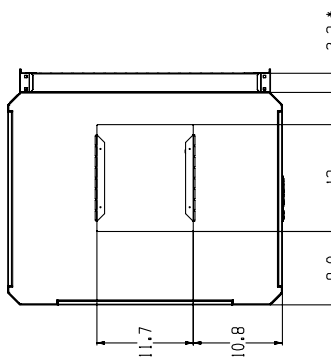

TOP VIEW - RIGHT HAND RETURN

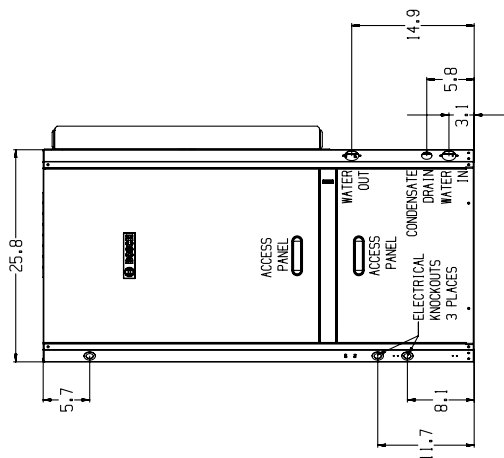

FRONT FRT

LM036-048 RIGHT & LEFT HAND VERTICAL CERTIFIED DRAWING
ROBERT BOSCH LLC RESERVES THE RIGHT TO MAKE CONTINUOUS IMPROVEMENTS THAT MAY AFFECT THE DIMENSIONS SHOWN

NOTE:
* ADD 1" FOR DUCT COLLAR/RETURN AIR DUCT FLANGE SHOWN UNBENT

Vertical Unit Dimensions

LM060/070– Vertical Top Discharge Water Source Heat Pump

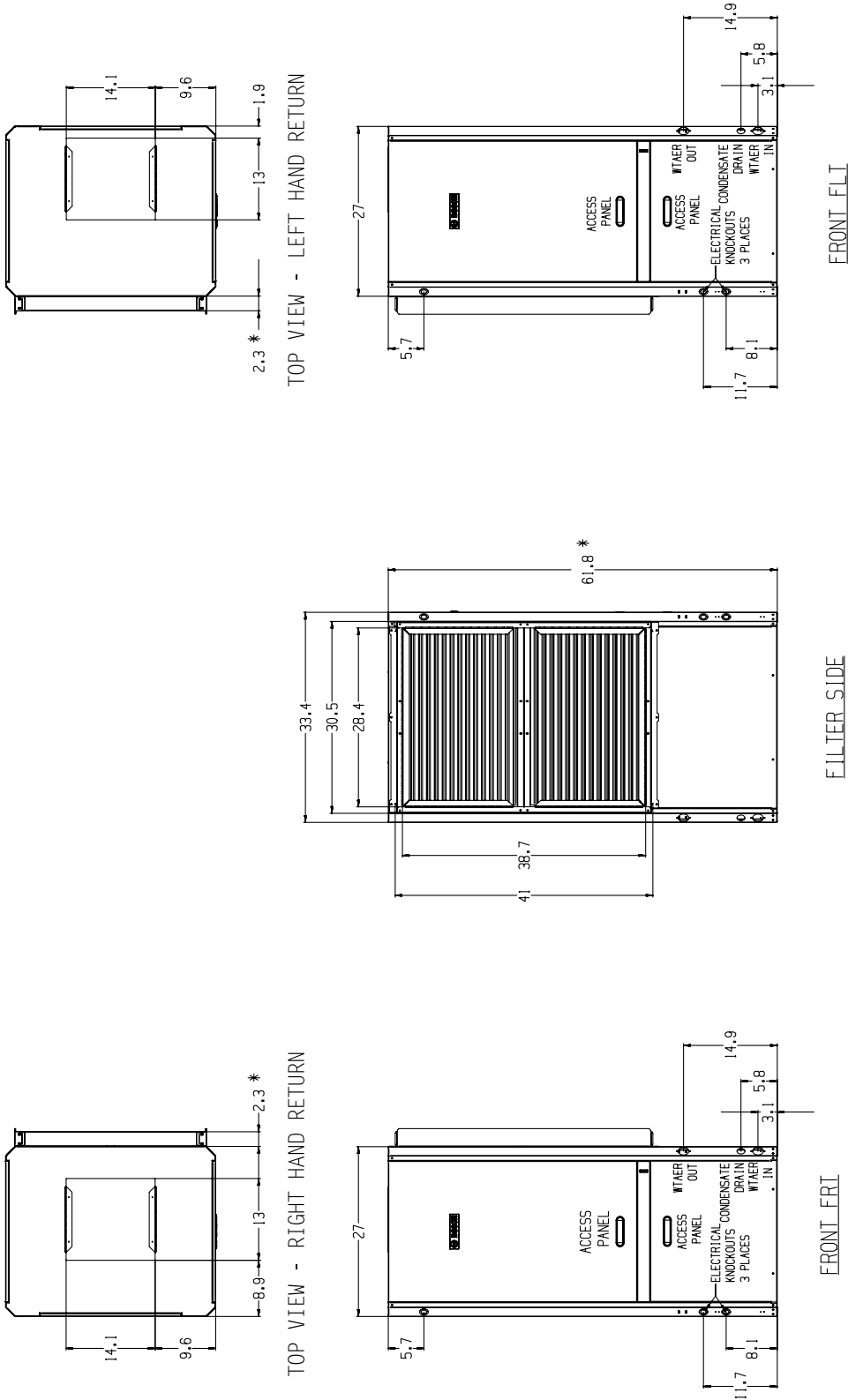

LM060-070 RIGHT & LEFT HAND VERTICAL CERTIFIED DRAWING
 ROBERT BOSCH LLC RESERVES THE RIGHT TO MAKE CONTINUOUS IMPROVEMENTS THAT MAY AFFECT THE DIMENSIONS SHOWN

NOTE:
 * ADD 1" FOR DUCT COLLAR/RETURN AIR DUCT FLANGE SHOWN UNBENT

Horizontal Unit Dimensions

Horizontal Water Source Heat Pump

Model	A WIDTH	B DEPTH	C HEIGHT	D FILTER RACK HEIGHT	E FILTER RACK WIDTH	F FILTER RACK DEPTH	G RETURN AIR DUCT WIDTH	H RETURN AIR DUCT HEIGHT	J WATER OUT	K DRAIN PORT	L WATER IN	M ELECTRICAL KNOCKOUT	N ELECTRICAL KNOCKOUT	O HEATER KNOCKOUT	SUPPLY AIR DUCT OPENING			S FILTER SIZE					
															P (RH)	Q (LH)	R (RH)		WATER CONNECTIONS				
LM024-HZ	25.1	64.1	19.7	19.5	36.1	3.4	34.0	16.2	17.2	1.3	15.1	2.5	8.1	11.7	9.9	6.5	2.0	10.0	7.5	7.5	10.8	3/4" F.P.T.	18X18X1 (2)
LM036-HZ	28.0	76.0	22.7	22.1	48.1	3.4	46.0	18.2	20.2	1.3	15.1	2.5	8.1	11.7	11.4	7.5	2.0	11.7	9.0	7.7	13.0	1" F.P.T.	20X24X1 (2)
LM048-HZ	28.0	76.0	22.7	22.1	48.1	3.4	46.0	18.2	20.2	1.3	15.1	2.5	8.1	11.7	11.4	7.5	2.0	11.7	9.0	7.7	13.0	1" F.P.T.	20X24X1 (2)
LM060-HZ	28.0	83.0	22.7	22.1	54.1	3.4	52.0	18.3	20.2	1.3	15.1	2.5	8.1	11.7	11.4	7.5	2.0	14.2	6.5	6.5	13.0	1" F.P.T.	18X20X1 (3)
LM070-HZ	28.0	83.0	22.7	22.1	54.1	3.4	52.0	18.3	20.2	1.3	15.1	2.5	8.1	11.7	11.4	7.5	2.0	14.2	6.5	6.5	13.0	1" F.P.T.	18X20X1 (3)

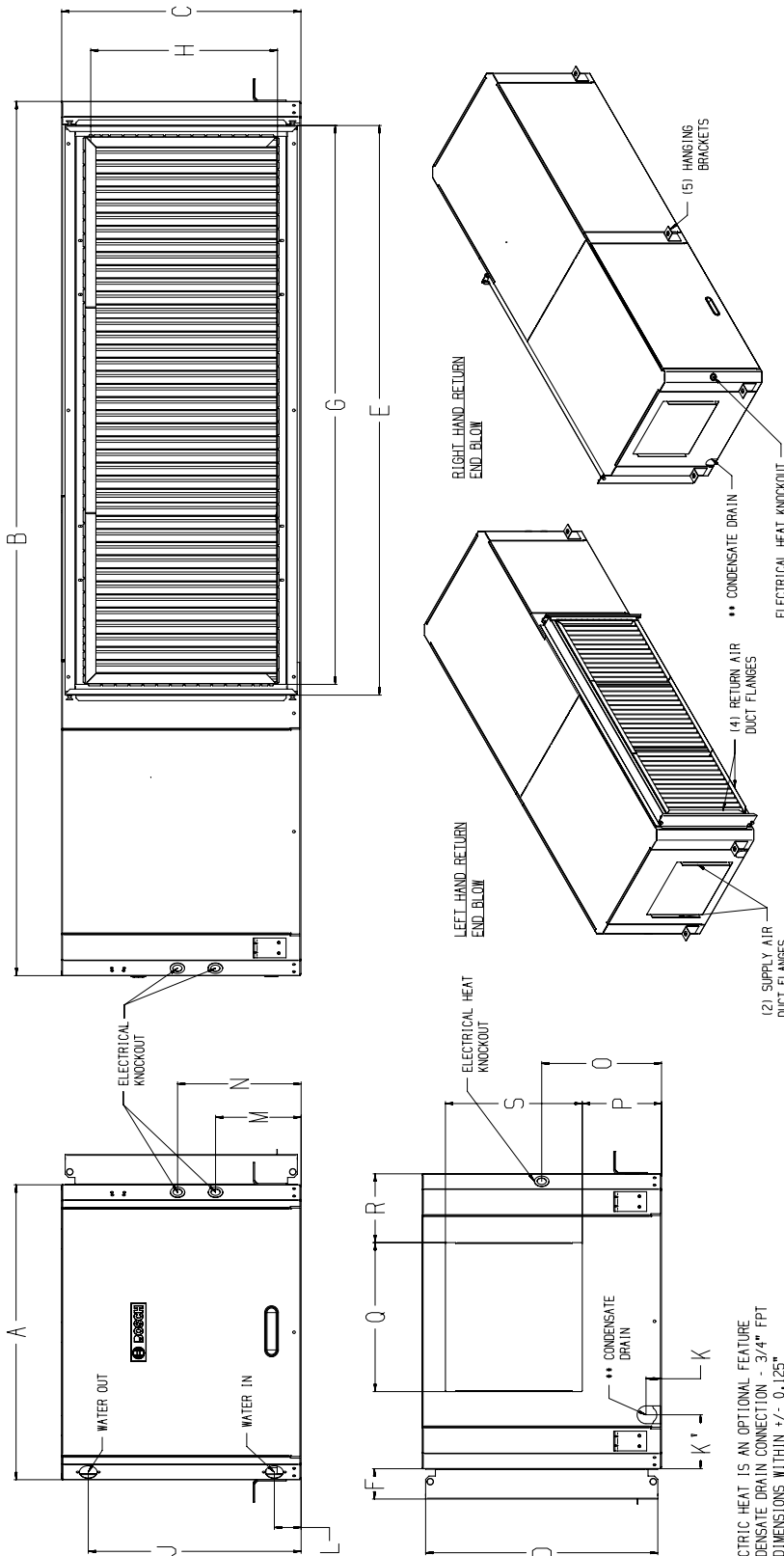

- NOTES
- ELECTRIC HEAT IS AN OPTIONAL FEATURE
 - CONDENSATE DRAIN CONNECTION - 3/4" FPT
 - ALL DIMENSIONS WITHIN +/- 0.125"
 - RETURN AIR & SUPPLY AIR DUCT FLANGES SHIPPED UNFOLDED
 - ALL DIMENSIONS ARE IN INCHES
 - SPECIFICATIONS SUBJECT TO CHANGE WITHOUT NOTICE
 - ADD 0.5" TO THE HEIGHT FOR BASE SUPPORT RAILS (NOT SHOWN)
 - UNITS CAN BE FIELD CONVERTED BETWEEN END BLOW AND STRAIGHT THROUGH SUPPLY AIR CONFIGURATIONS WITH KITS

SUPPLY AIR CONFIGURATION: END BLOW

Horizontal Unit Dimensions

Horizontal Water Source Heat Pump

Model	A WIDTH	B DEPTH	C HEIGHT	D FILTER RACK HEIGHT	E FILTER RACK WIDTH	F RETURN AIR DUCT WIDTH	G RETURN AIR DUCT HEIGHT	H WATER OUT	J WATER OUT	K DRAIN PORT	K' WATER IN	L WATER IN	M ELECTRICAL KNOCKOUT	N ELECTRICAL KNOCKOUT	O HEATER KNOCKOUT	SUPPLY AIR DUCT OPENING			S WATER CONNECTIONS	FILTER SIZE			
																P*(LH)	Q	R*(LH)					
LM024-HZ	25.1	64.1	19.7	19.5	36.1	3.4	34.0	16.2	17.2	1.3	5.1	2.5	8.1	11.7	9.9	2.0	6.5	10.0	11.8	10.8	3/4" F.P.T.	18X18X1 (2)	
LM036-HZ	28.0	76.0	22.7	22.1	48.1	3.4	46.0	18.2	20.2	1.3	5.1	2.5	8.1	11.7	11.4	2.0	7.5	11.7	12.9	13.0	1" F.P.T.	20X24X1 (2)	
LM048-HZ	28.0	76.0	22.7	22.1	48.1	3.4	46.0	18.2	20.2	1.3	5.1	2.5	8.1	11.7	11.4	2.0	7.5	11.7	12.9	13.0	1" F.P.T.	20X24X1 (2)	
LM060-HZ	28.0	83.0	22.7	22.1	54.1	3.4	52.0	18.3	20.2	1.3	5.1	2.5	8.1	11.7	11.4	2.0	7.5	14.2	15.1	15.1	13.0	1" F.P.T.	18X20X1 (3)
LM070-HZ	28.0	83.0	22.7	22.1	54.1	3.4	52.0	18.3	20.2	1.3	5.1	2.5	8.1	11.7	11.4	2.0	7.5	14.2	15.1	15.1	13.0	1" F.P.T.	18X20X1 (3)

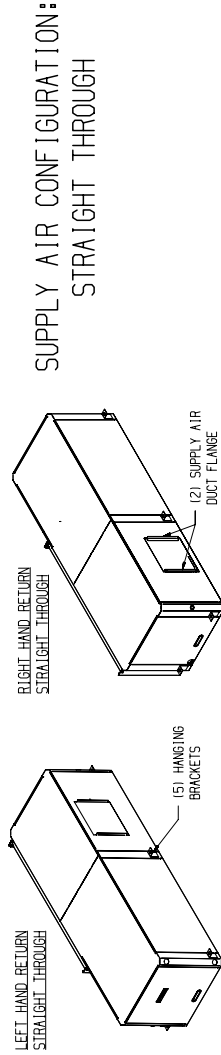
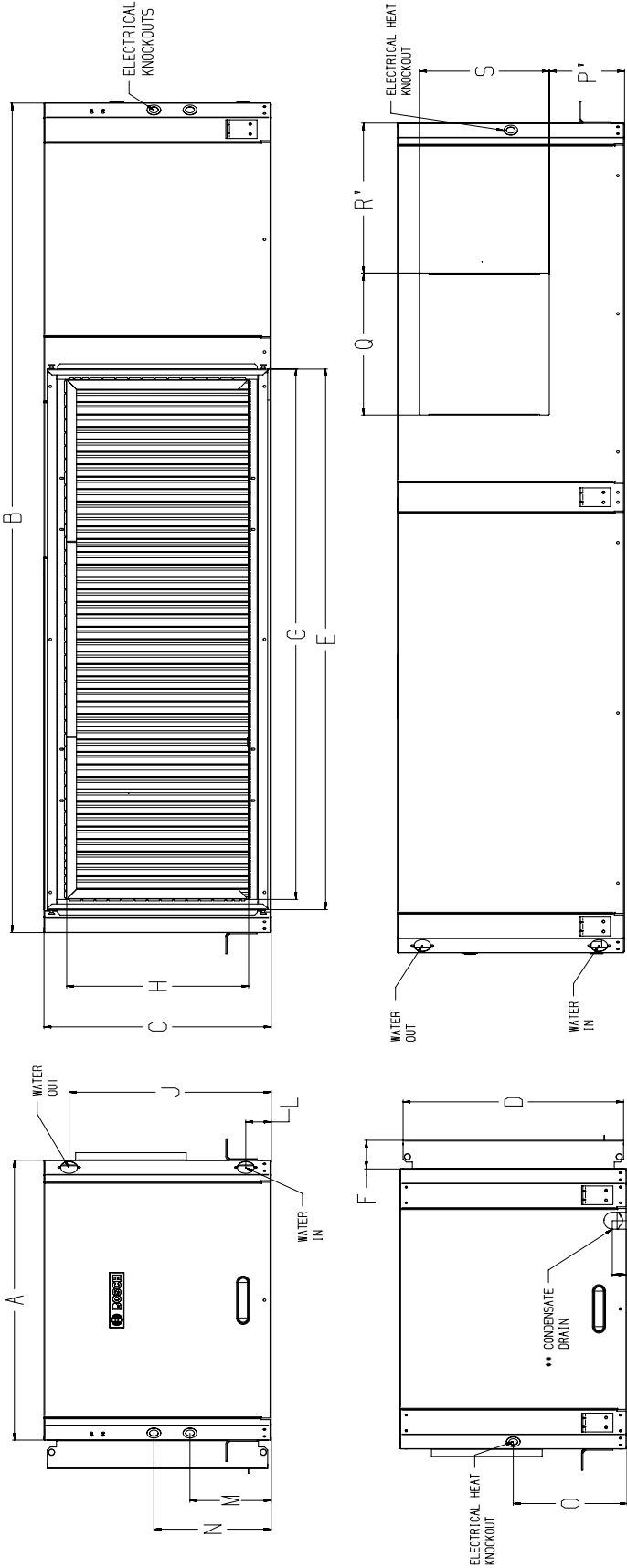

- NOTES**
- ELECTRIC HEAT IS AN OPTIONAL FEATURE
 - CONDENSATE DRAIN CONNECTION - 3/4" FPT
 - ALL DIMENSIONS WITHIN +/- 0.125"
 - RETURN AIR & SUPPLY AIR DUCT FLANGES SHIPPED UNFOLDED
 - ALL DIMENSIONS ARE IN INCHES
 - SPECIFICATIONS SUBJECT TO CHANGE WITHOUT NOTICE
 - ADD 0.5" TO THE HEIGHT FOR BASE SUPPORT RAILS (NOT SHOWN)
 - UNITS CAN BE FIELD CONVERTED BETWEEN END BLOW AND STRAIGHT THROUGH SUPPLY AIR CONFIGURATIONS WITH KITS

Horizontal Unit Dimensions

Horizontal Water Source Heat Pump

Model	A	B	C	D	E
LM024-HZ	2.634	32.817	65.225	2.634	1.125
LM036-HZ	2.634	33.972	77.125	2.634	1.125
LM048-HZ	2.634	33.972	77.125	2.634	1.125
LM060-HZ	2.634	45.573	84.125	2.634	1.125
LM070-HZ	2.634	45.573	84.125	2.634	1.125

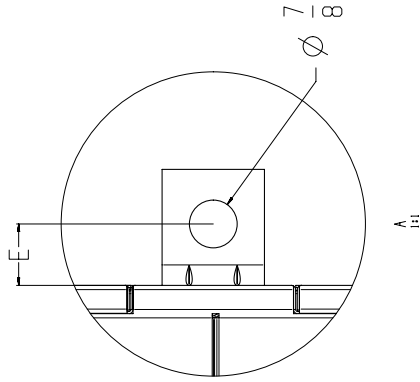

NOTES
 -ALL DIMENSIONS WITHIN +/- 0.125"
 -ALL DIMENSIONS ARE IN INCHES
 -SPECIFICATIONS SUBJECT TO CHANGE WITHOUT NOTICE
 -DIMENSION "E" IS TYPICAL FOR ALL MODELS, CONFIGURATIONS AND BRACKET POSITIONS

HANGING BRACKET LOCATION SPECIFICATIONS

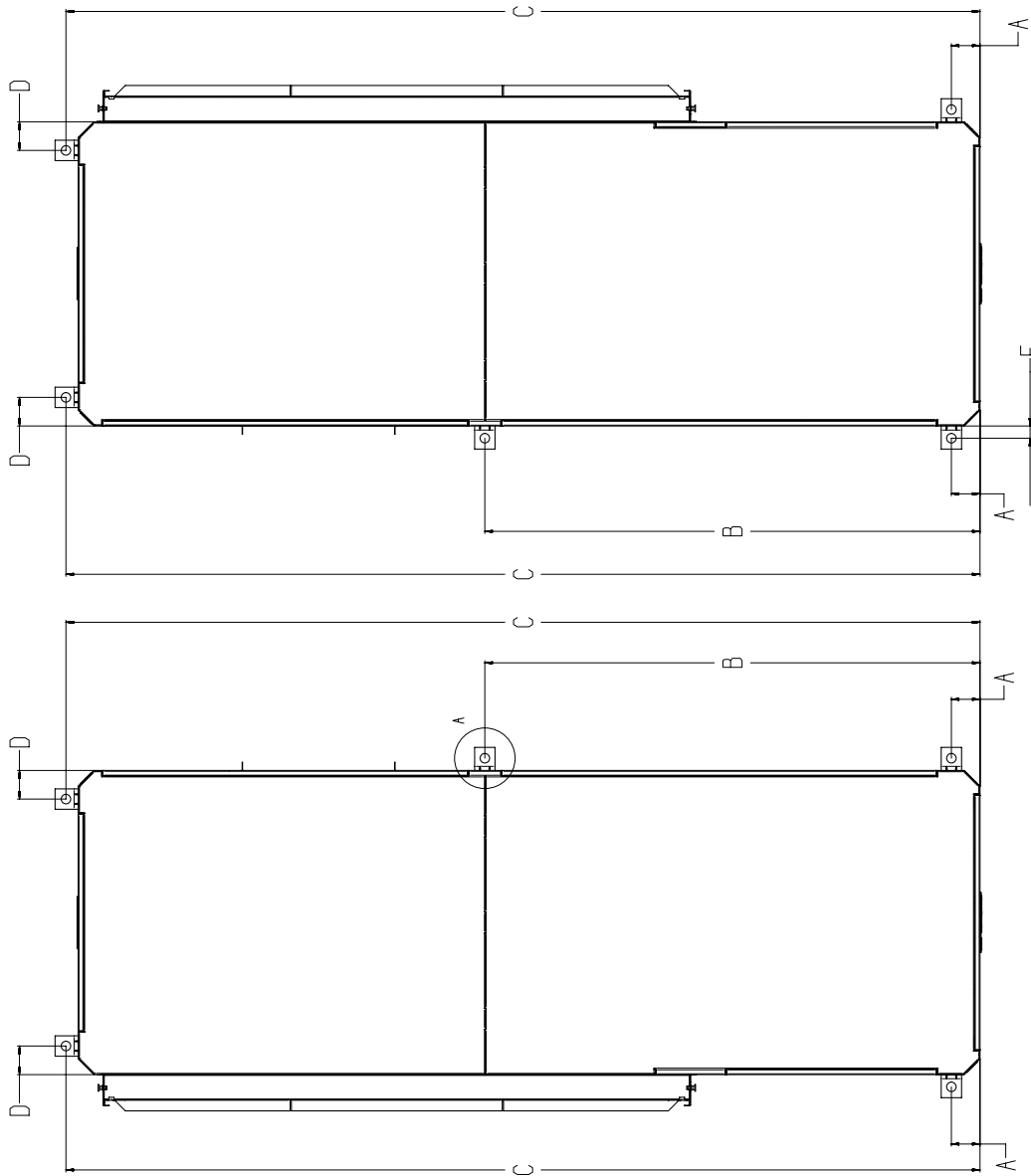

Horizontal Unit Dimensions

LM024 – Right Hand Horizontal Water Source Heat Pump

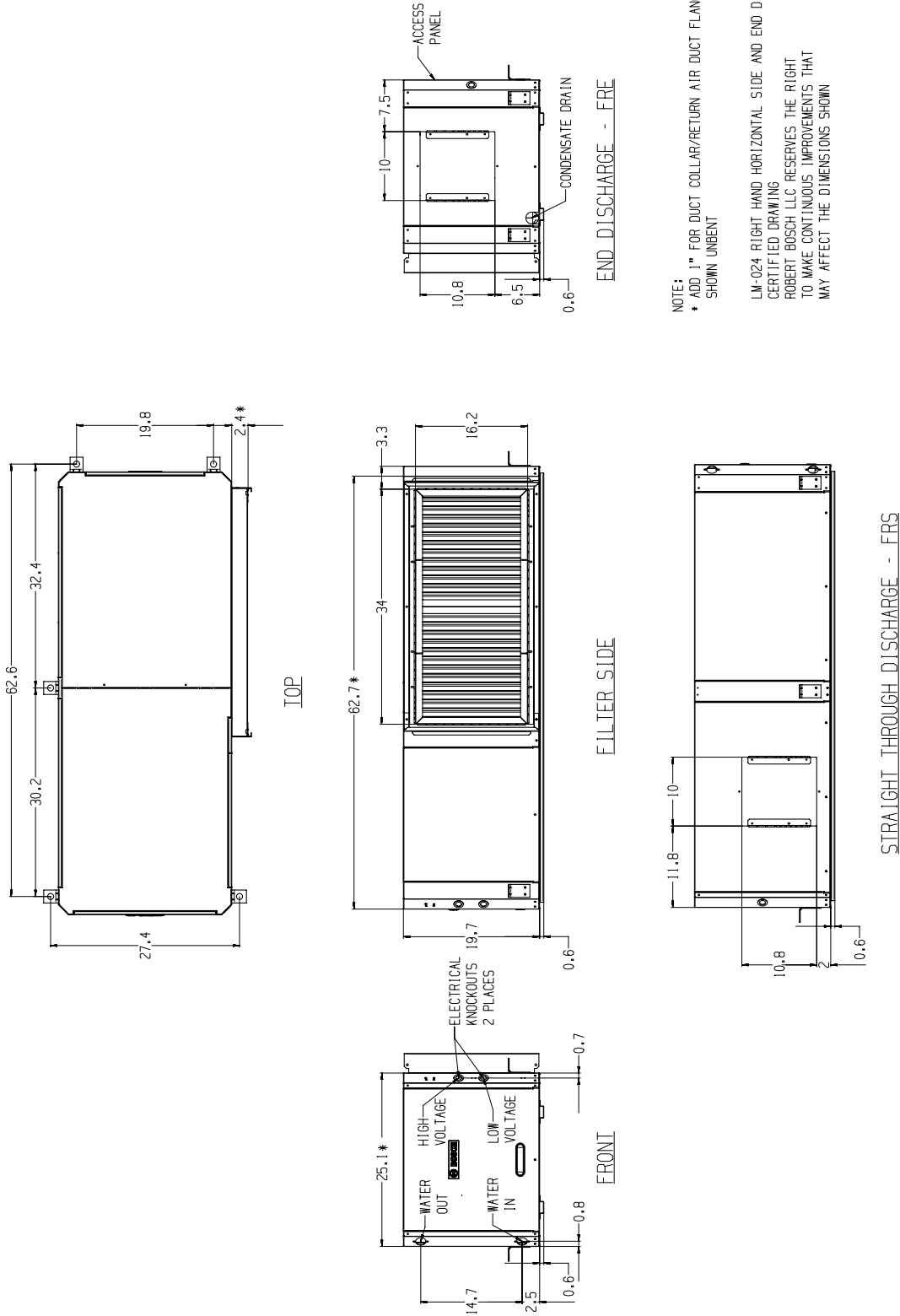

NOTE:
* ADD 1" FOR DUCT COLLAR/RETURN AIR DUCT FLANGE SHOWN UNBENT

LM-024 RIGHT HAND HORIZONTAL SIDE AND END DISCHARGE CERTIFIED DRAWING
ROBERT BOSCH LLC RESERVES THE RIGHT TO MAKE CONTINUOUS IMPROVEMENTS THAT MAY AFFECT THE DIMENSIONS SHOWN

Horizontal Unit Dimensions

LM024 – Left Hand Horizontal Water Source Heat Pump

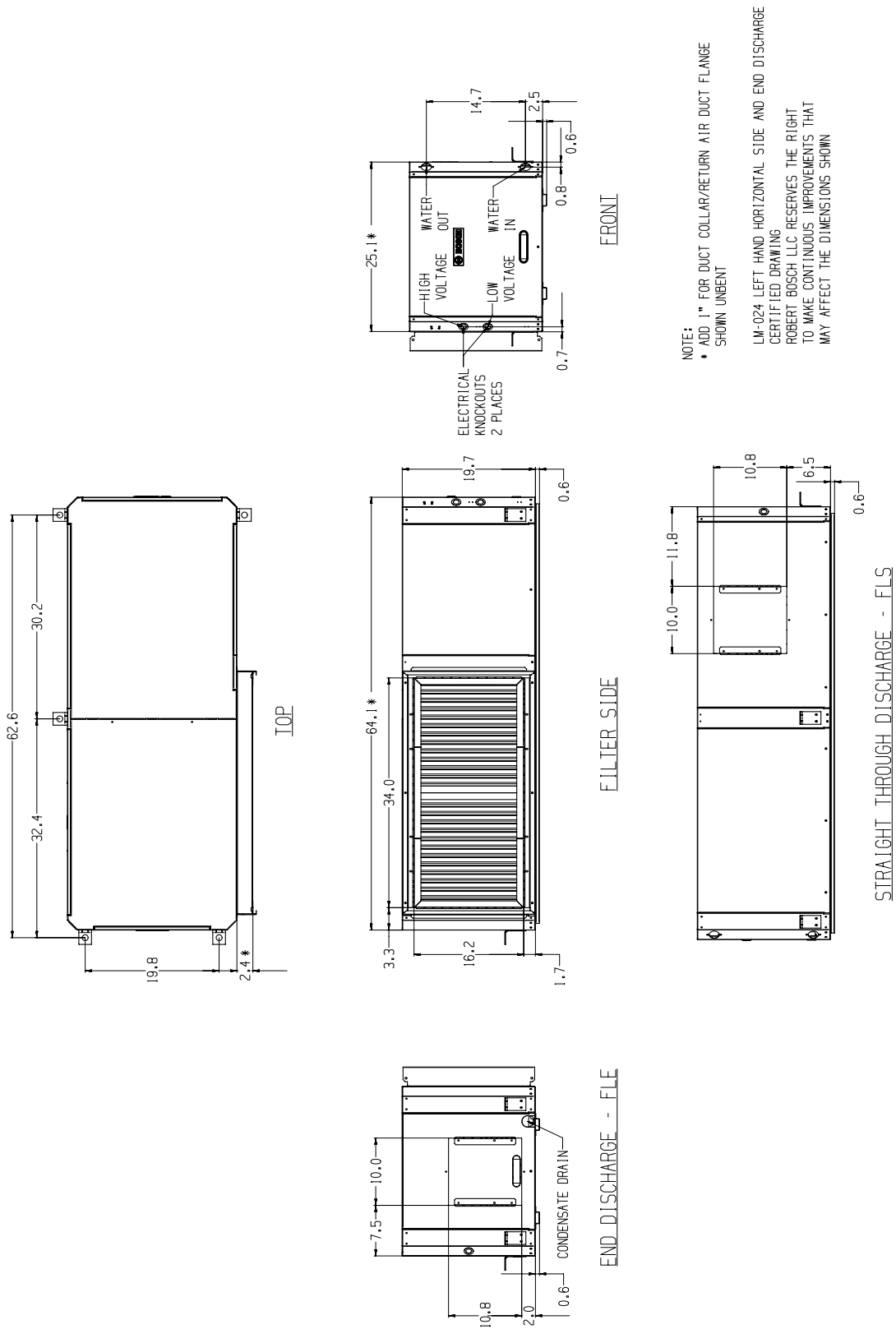

Horizontal Unit Dimensions

LM036/048 – Right Hand Horizontal Water Source Heat Pump

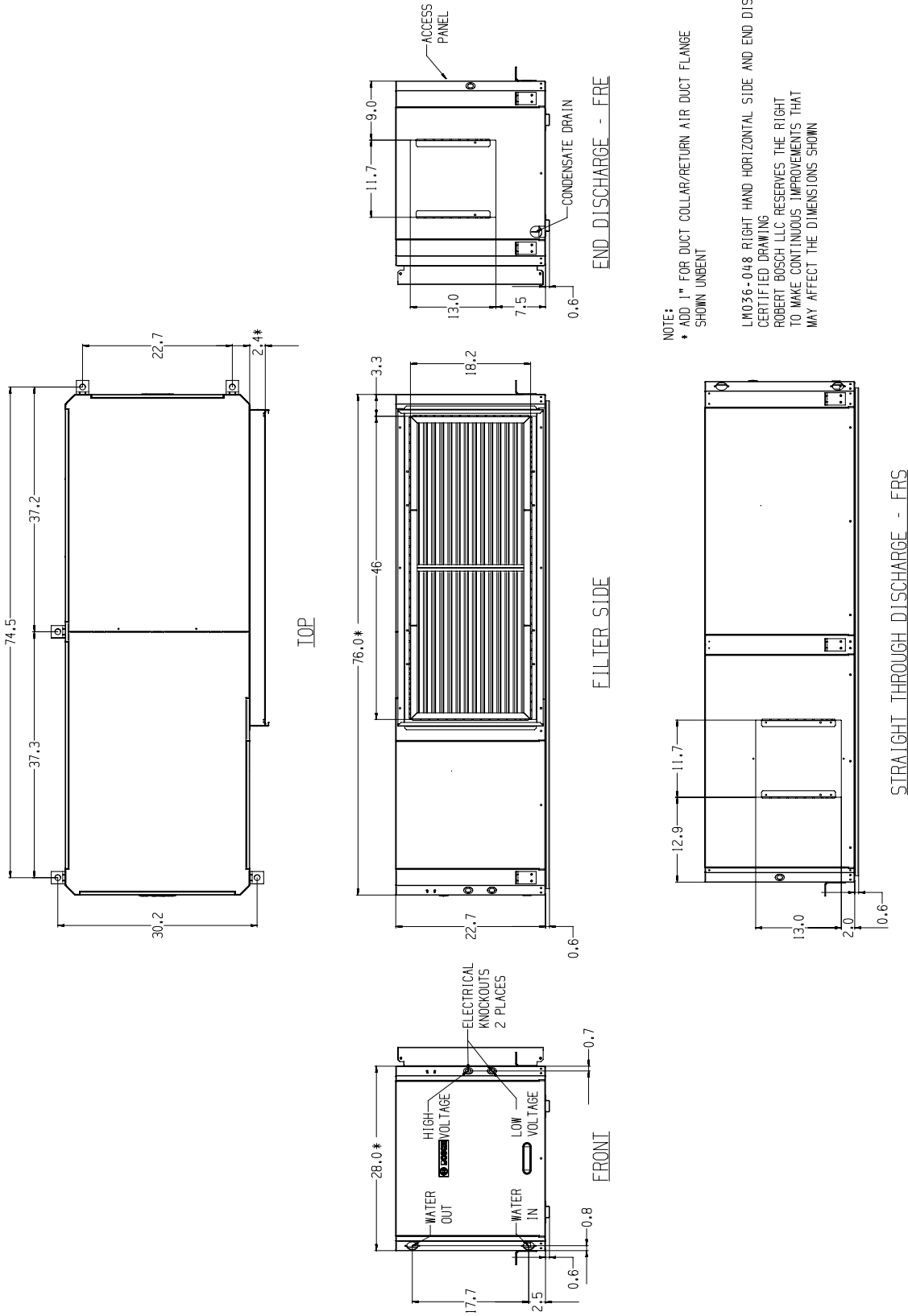

NOTE:
 * ADD .1" FOR DUCT COLLAR/RETURN AIR DUCT FLANGE SHOWN UNBENT
 LM036-048 RIGHT HAND HORIZONTAL SIDE AND END DISCHARGE CERTIFIED DRAWING
 ROBERT BOSCH LLC RESERVES THE RIGHT TO MAKE CONTINUOUS IMPROVEMENTS THAT MAY AFFECT THE DIMENSIONS SHOWN

Horizontal Unit Dimensions

LM036/048 – Left Hand Horizontal Water Source Heat Pump

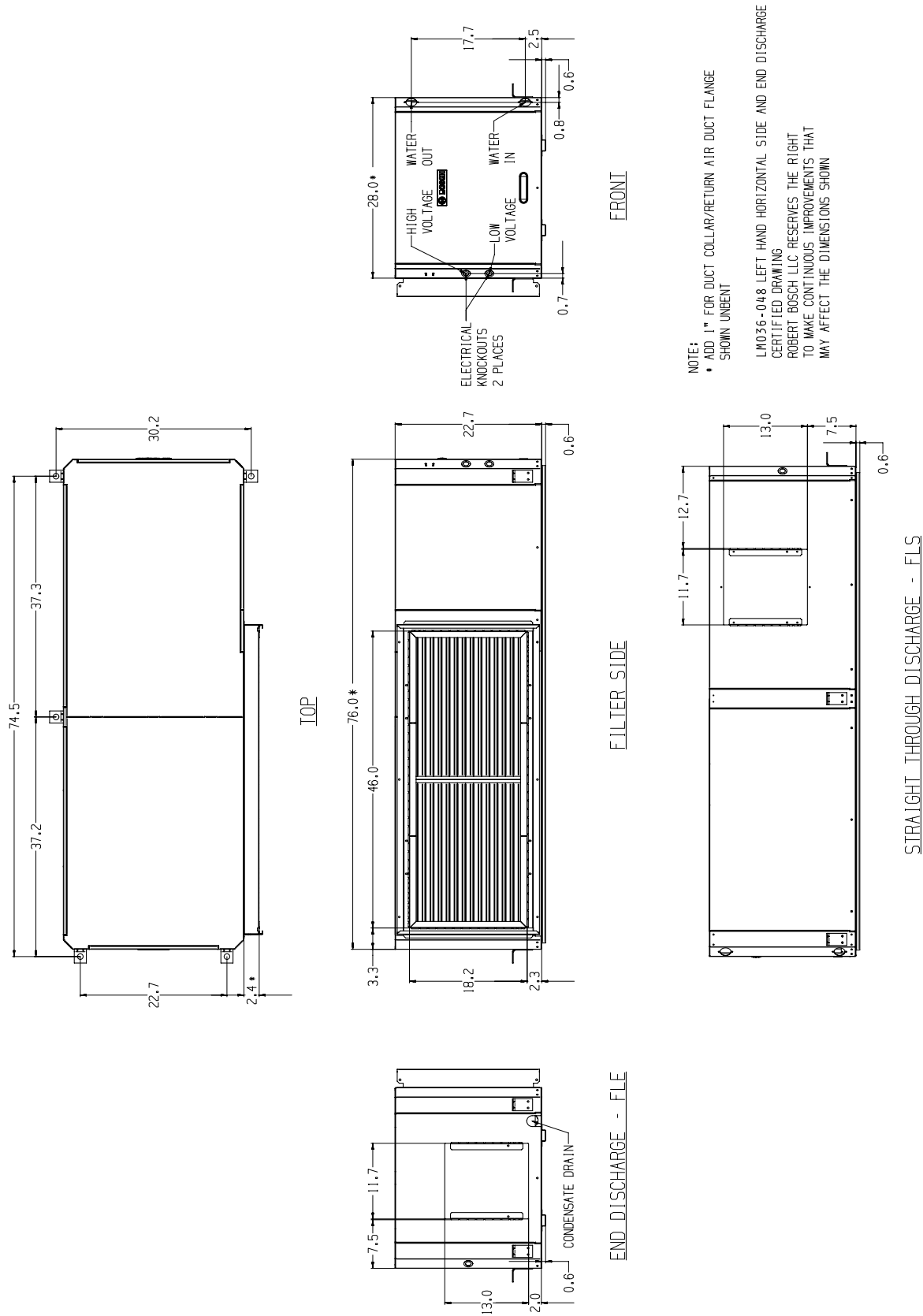

Horizontal Unit Dimensions

LM060/070 – Right Hand Horizontal Water Source Heat Pump

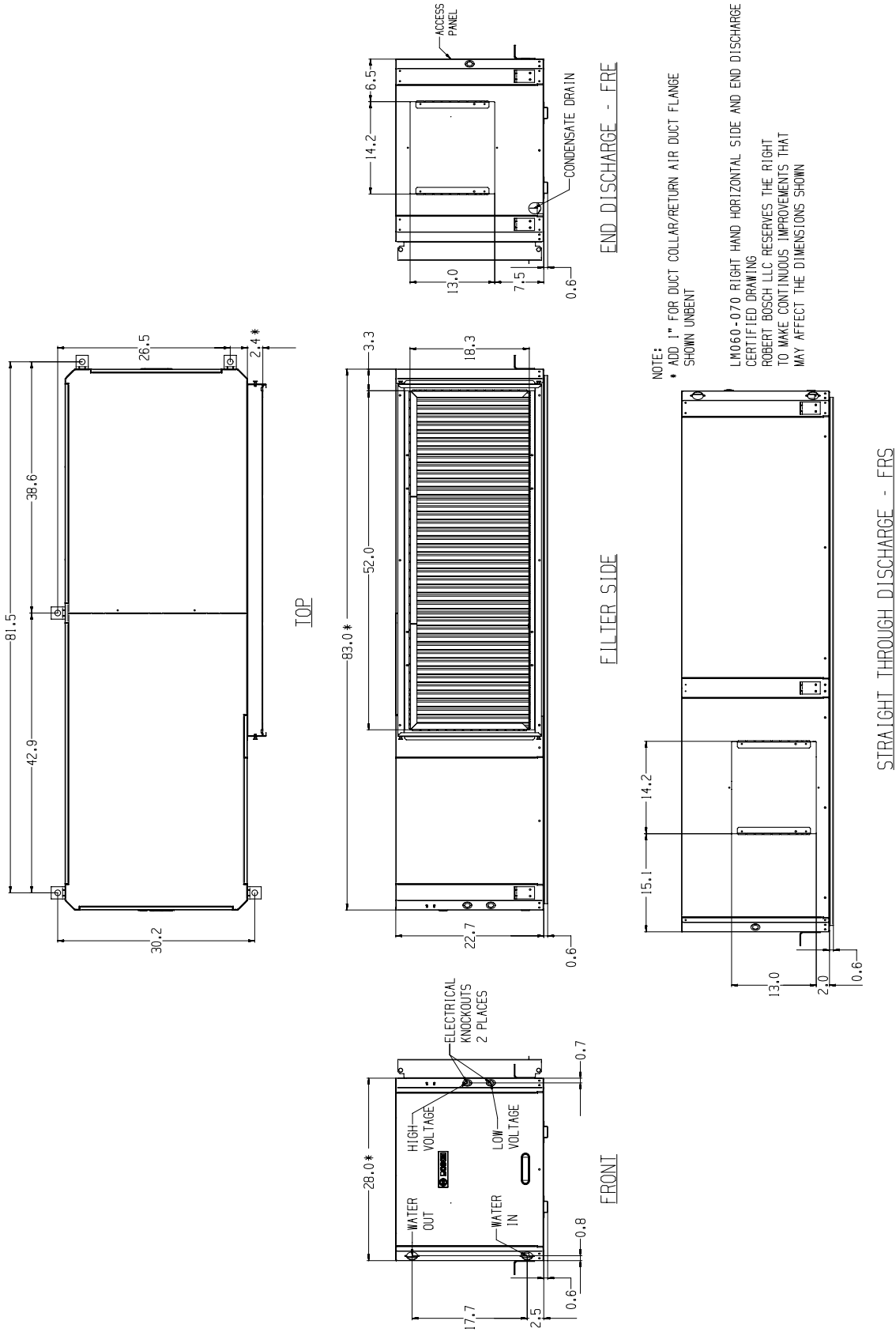

Horizontal Unit Dimensions

LM060/070 – Left Hand Horizontal Water Source Heat Pump

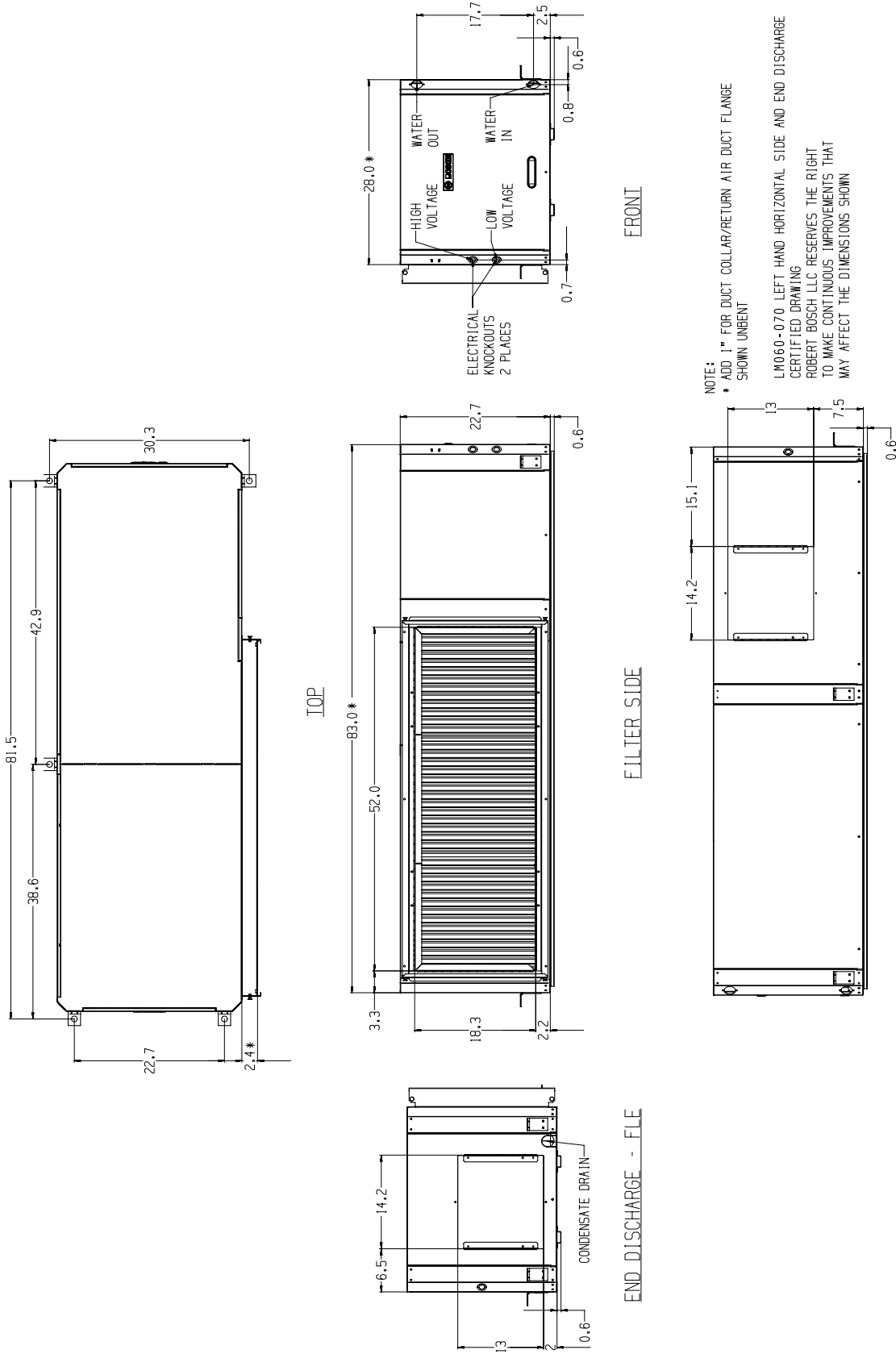

Specification Guide

1.0 General

Furnish and install LM series water source heat pumps as indicated on the plans with capacities and characteristics as listed in the schedule and the specifications that follow. The units shall be manufactured in an ISO 9001:2000 certified facility.

2.0 Horizontal/Vertical Water Source Heat Pumps

Units shall be designed to operate throughout the range of entering fluid temperature of 40°F to 120°F in the cooling mode and 20°F to 90°F in the heating mode. Equivalent units from other manufacturers can be proposed provided approval to bid is given 10 days prior to bid closing. All equipment with a nominal capacity of 134,000 BTUH Total Cooling or lower must be listed in the current AHRI Applied Equipment Directory under the AHRI Standard ARIISO- 13256-1, WLHP, GWHP and GLHP Rating. All equipment in this section must meet or exceed the national standard minimum EER and COP as listed in ASHRAE 90.1 All units shall conform to UL1995 standard and certified to CAN/CSA C22.1 No 236 by Intertek-ETL.

All units shall have ARI-13256-1 labels, and ETL/UL or NRTL or CSA labels.

2.01 Basic Construction

- A. Units shall have the air flow arrangement as shown on the plans. If units with these arrangements are not used, the contractor supplying the water source heat pumps is responsible for any extra costs incurred by other trades and must submit detailed mechanical drawings showing ductwork requirements and changes or relocation of any other mechanical or electrical system. If other arrangements make servicing difficult the contractor must provide access panels and clear routes to ease service. The architect must approve all changes 10 days prior to bid.
- B. All units shall have stainless steel drain pans to comply with this project's IAQ requirements. No exceptions shall be allowed.
- C. All water source heat pumps shall be fabricated from sheet metal finished with G90 galvanized steel. All interior surfaces shall be lined with 1/2 inch thick, multi density acoustic insulation. All insulation must meet NFPA 90A and be certified to meet the GREENGUARD Indoor Air Quality Standard for Low Emitting Products. One blower access panel and two compressor compartment access panels shall be removable with supply and return air ductwork in place.

Option to C: All interior surfaces shall be lined with ½" thick closed cell foam insulation
- D. Unit shall have a floating base pan consisting of a ½" (12 mm) thick high density rubber pad between the compressor base plate and the unit base pan to prevent transmission of vibration to the structure.
- E. All units shall have a factory installed four sided filter rack capable of accepting either one or two inch filters. Units shall have a 1 inch thick throwaway type glass fiber filter as standard. The filter rack shall incorporate a 1 inch duct flange. The contractor shall purchase one spare set of filters and replace factory-shipped filters upon completion of start-up.

Option to E: All units shall have a factory installed four sided filter rack with 2" MERV8 filters.

Option to E: All units shall have a factory installed four sided filter rack with 2" MERV13 filters.
- F. Cabinets shall have separate holes and knockouts for entrance of line voltage and low voltage control wiring. Supply and return water connections shall be brass FPT fittings and shall be securely mounted flush to the cabinet allowing for connection to a flexible hose without the use of a back-up wrench. Water connections which protrude through the cabinet shall not be allowed.
- G. Hanging brackets shall be provided as standard for horizontal units
- H. All units shall have condensate overflow switch, Air-Coil and Water-Coil Freeze sensor as standard.

Specification Guide

2.02 Fan and Motor Assembly

- A. Units shall have a direct-drive centrifugal fan. The fan motor shall be a factory pre-programmed high efficiency constant torque ECM type.

The fan motor shall be isolated from the fan housing by torsionally flexible isolation.

Option for A: The fan motor shall be a pre-programmed high efficient constant CFM ECM type

- B. The fan and motor assembly must be capable of overcoming the external static pressures as shown on the schedule. External static pressure rating of the unit shall be based on a wet coil. Ratings based on a dry coil shall NOT be acceptable.
- C. All units shall have removable blower inlet ring as standard for ease of service and maintenance.

2.03 Refrigerant Circuit

Units shall use R-410A refrigerant. All units shall have a factory sealed and fully charged refrigerant circuit with the following components:

- A. Two stage hermetic compressor specifically designed for heat pump operation and shall be internally protected) with thermal overload protection and mounted on rubber vibration isolators.
- B. Bi directional refrigerant metering thermal expansion valves
- C. Finned tube refrigerant to air heat exchanger not exceeding 14 fins per inch. Refrigerant to air heat exchangers shall utilize enhanced aluminum fins and rifled copper tube construction rated to withstand 600 PSIG refrigerant working pressure. All air coils shall have non-ferrous aluminum end plates.
- Option for C Coils shall have Duo-Guard coating for enhanced protection against formicary and other corrosion. Copper tubes shall be tin coated and aluminum fins coated to pass 1000 hour ASTM B117 salt fog testing.
- D. Reversing valve. Reversing valves shall be four way solenoid activated refrigerant valves

which shall fail to the heating operation should the solenoid fail to function. Reversing valves which fail to the cooling operation shall not be allowed.

- E. Coaxial (tube in tube) refrigerant to water heat exchanger. Refrigerant to water heat exchangers shall be insulated and with copper inner water tube and steel outer refrigerant tube design rated to withstand 600 PSIG working refrigerant pressure and 400 PSIG working water pressure. Shell and Tube style refrigerant to water heat exchangers shall be treated as pressure vessels and shall require refrigerant pressure relief valves piped to the exterior of the building. The contractor supplying the water source heat pumps with Shell and Tube heat exchangers shall be responsible for any additional installation costs. Brazed Plate water to refrigerant heat exchangers shall require additional centrifugal separators added to the supply water piping at each unit. Each separator shall have an automated clean out valve piped to a waste line. The contractor supplying water source heat pumps with Brazed Plate heat exchangers shall be responsible for any additional costs.

Option for E: Cupro-Nickel water coil – The refrigerant to water heat exchanger shall be of cupro-nickel inner water tube construction.

- F. Safety controls including both a high pressure and low pressure switch. Temperature sensors shall not replace these safety switches. See the controls section of this specification for additional information.
- G. Access fittings shall be factory installed on high and low pressure refrigerant lines to facilitate field service.
- H. Activation of any safety device shall prevent compressor operation via a lockout circuit. The lockout circuit shall be reset at the thermostat or at the contractor supplied disconnect switch. Units which may be reset at the disconnect switch only shall not be acceptable. Refer to solid state safety circuit below.

Specification Guide

2.04 Electrical

A control box shall be located within the unit and shall contain a transformer, controls for the compressor, reversing valve and fan motor operation and shall have a terminal block for low voltage field wiring connections. The transformer shall be rated for a minimum 75 VA. All units shall be name-plated for use with time delay fuses or HACR circuit breakers. Unit controls shall be 24 volts.

2.05 Solid-State Safety Circuit

All units shall have a solid-state UPM safety control circuit with the following features:

1. Anti-short cycle time delay on compressor operation.
2. Random start on power up mode.
3. Brown out/Surge/Power Interruption protection.
4. Low Pressure Switch 120 second bypass timer.
5. Shutdown on the following fault indications:
 - a. high or low refrigerant pressure safety switches inputs.
 - b. Freeze sensors shall monitor refrigerant temperature to the water coil in the heating mode and refrigerant coil in the cooling mode.
 - c. condensate sensor input.
6. Alarm output which closes for selectable dry contact closure or 24 VAC remote fault indication.
7. Alarm output selectable for constant output for general alarm notification, or pulse output for annunciation of the specific fault alarm
8. Selectable reset of unit at thermostat or disconnect.
9. Automatic intelligent reset. Unit shall automatically reset after a safety shut down and restart the unit after the anti-short cycle timer and random start timer expire. Should a fault re-occur within 60 minutes after reset, then a permanent lockout will occur. Reset attempts shall be selectable for either 2 or 4 tries. A condensate overflow will place the unit in an immediate hard lockout.
10. Ability to defeat time delays for servicing.
11. A light emitting diode (LED) to indicate safety alarms. The LED shall annunciate the following alarms:
 - a. high refrigerant pressure,
 - b. low refrigerant pressure,
 - c. low refrigerant temperature to the water coil in the heating operation,
 - d. high level of condensate in the drain pan,
 - e. brown out/surge/ power interruption.
12. The LED will display each fault condition as soon as the fault occurs. If a permanent lockout occurs, then the fault LED will display the type of fault until the unit is reset.
13. UL listed, CUL listed, and RFI, ESD, and transient protected.

Freeze Protection: A freeze stat shall sense the entering refrigerant temperature to the coaxial coil (in the heating mode) and shall activate the compressor lockout circuit when the refrigerant temperature drops below either 15°F or 30°F. The factory default is 30°F and the temperature setting may be set at 15°F by cutting the resistor (R42) located above dip switch. The freeze stat may not provide protection in the case of loss of flow in the heating mode. A flow switch or pressure differential switch is recommended to prevent unit operation in case of loss of flow. A second freeze sensor shall be mounted at the refrigerant inlet to the air coil. Should the refrigerant temperature drop below 30°F the unit will go into a soft lockout.

Specification Guide

2.06 Options

- A. Extra quiet construction: Optional compressor blanket shall be provided on units having a capacity above 24,000 BTUH.
- B. Hot Gas Reheat: Units as noted on the schedule shall be equipped with optional Hot Gas Reheat (HGRH).
On/Off HGRH shall be controlled by a humidistat connected to the unit H terminal and shall start the unit in the reheat mode should the humidity be above set point once the thermostat control is satisfied. Cooling or heating requirements shall take precedent over HGRH.
- C. Water Differential Switch. A water differential switch shall be factory piped between the fluid inlet and outlet piping to prevent unit operation if there is no fluid flow.
- D. DDC Controls: Unit shall be equipped with a factory installed DDC control capable of interfacing with BACnet, Modbus, N2 and Lonworks. The controller shall be pre-programmed to control the unit and monitor the safety controls. The unit shall be able to operate as a standalone or be incorporated into a building management system. A leaving water and leaving air sensor shall be installed in the unit. Wall sensors shall be available for controlling zone temperature.
- E. Unit mounted disconnect. A non fused factory mounted disconnect shall be installed on the unit.
- F. Two Way Motorized Water valve: A two way motorized water valve shall be mounted in the interior of the unit. The valve shall cycle open whenever there is a call for compressor operation. The valve shall be equipped with an end switch.
- G. Internal Load Match Pump: An internal load match pump shall be installed in the unit. 208-230 volt units only
- H. Conversion Kit for horizontal discharge configuration shall be available should the discharge arrangement need to be field changed.
- I. Electric Heat: Factory installed UL listed electric heater packages shall be available for the units. Available only on vertical units with top discharge and horizontal units with end blow configuration.
- J. The following relays shall be factory installed in the unit
 - a) EMS Relay for remote enabling of the unit.
 - b) Auxiliary pump relay to enable a pump operation when calling for compressor operation.
 - c) Compressor monitoring relay – provides a contact closure whenever the compressor contactor is energized
- L. Soft Start shall be installed to limit inrush current on startup. 208/230 V units only.
- M. Phase Loss and reversal protection shall be provided on the unit to protect the compressor from operating in reverse rotation.
- N. A Comfort alert module shall be installed in the units to assist in service diagnostics.

3.0 Hose Kits

All units shall be connected by hoses and have a maximum working pressure 400 PSI for sizes ½" – 1" and 300 PSI for sizes 1 ¼ – 2". The hoses shall be either 2 or 3 feet long, with steel constructed fittings and assembly as "fire rated" tested according to UL 94 with a VO rating of ASTM 84. Non-fire rated hoses are not acceptable. Optional ball valves with P/T ports, flow controller, Y strainer and electric valve shall be included as specified in the schedule.

Bosch Thermotechnology Corp.

601 N.W. 65th Court, Fort Lauderdale, FL 33309

Phone: 954-776-5471 | Fax: 954-776-5529

fhp-mfg.com

BTC 760404301 A 1.2014

