

WW and WT Models



BOSCH

Installation, Operation and Maintenance Manual

Contents

Model Nomenclature	2	Cooling Mode	12
Initial Inspection	3	Auto Changeover Mode.....	12
General Description.....	3	Unit Protection	12
Moving And Storage.....	3	Brownout Protection	13
Safety Considerations.....	3	Manual Lockout	13
Location	3	Lead -Lag	13
Installation.....	3	Pump Cycling.....	13
Minimal System Volume.....	3	Operating Instructions.....	13
Electrical.....	3	User Interface	13
Piping.....	3	Up Button	13
Cooling Tower / Boiler Application	5	Down Button.....	14
Well Water Systems	6	Led Indicators	
Earth Coupled Geothermal Systems.....	7	User Adjustable Set Tings Chart.....	14
Typical Load Side Applications	7	Setting Up The Controller.....	14
Some Typical Uses Are As Follows.....	7	Initial Configuration.....	14
Considerations	9	System Checkout.....	15
Sequence of Operation.....	9	Unit Start-Up.....	15
Water To Water Unit Controller (Optional)	11	Chiller Mode	16
Features.....	11	Boiler Mode	16
Unit Sensors	11	Wiring Diagrams	17
Modes Of Operation	11	Troubleshooting.....	26
Off Mode.....	11	Unit Check-Out Sheet	27
Heating Mode	11		

MODEL NOMENCLATURE

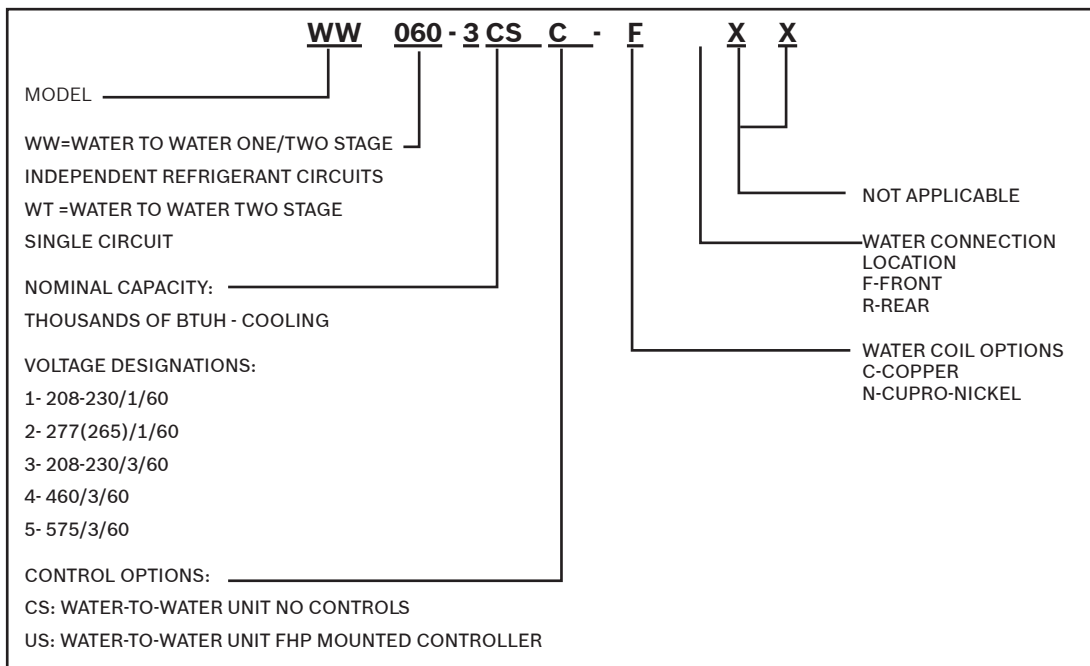

INITIAL INSPECTION

Be certain to inspect all cartons or crates on each unit as received at the job site before signing the freight bill. Verify that all items have been received and that there are no visible damages; note any shortages or damages on all copies of the freight bill. In the event of damage or shortage, remember that the purchaser is responsible for filing the necessary claims with the carrier. Concealed damages not discovered until after removing the units from the packaging must be reported to the carrier within 24 hours of receipt.

GENERAL DESCRIPTION

The Water-to-Water series unit is a refrigeration machine that provides the best combination of performance and efficiency available. Safety devices are built into each unit to provide the maximum system protection possible when properly installed and maintained.

The Water-to-Water series units are Underwriters Laboratories (UL) and (cUL) listed for safety. The Water-to-Water series units are designed to operate with entering liquid temperature between 25° F and 110° F. (see specifications data sheets for limits).



NOTE: 50°F Min. EWT for well water applications with sufficient water flow to prevent freezing. Antifreeze solution is required for all closed loop applications. Cooling Tower/Boiler and Earth Coupled (Geo Thermal) applications should have sufficient antifreeze solution to protect against extreme conditions and equipment failure. Frozen water coils are not covered under warranty.

MOVING AND STORAGE

If the equipment is not needed for immediate installation upon its arrival at the job site, it should be left in its shipping carton and stored in a clean, dry area. Units must only be stored or moved in the normal upright position as indicated by the “UP” arrows on each carton at all times.

SAFETY CONSIDERATIONS

Installation and servicing of this equipment can be hazardous due to system pressure and electrical components. Only trained and qualified personnel should install, repair, or service the equipment.



WARNING: Before performing service or maintenance operations on the system, turn off main power to the unit. Electrical shock could cause personal injury or death.

When working on equipment, always observe precautions described in the literature, tags, and labels attached to the unit. Follow all safety codes. Wear safety glasses and work gloves. Use a quenching cloth for

brazing, and place a fire extinguisher close to the work area.

LOCATION

The unit should be centrally located with respect to the distribution system. The unit should be installed in an indoor area that allows easy removal of the access panels, and has enough room for service personnel to perform maintenance or repair. Provide sufficient room to make fluid, and electrical connections. These units are not approved for outdoor installation; therefore, they must be installed inside the conditioned structure. Do not locate in areas that are subject to freezing.

INSTALLATION

The Water-to-Water series unit should be mounted level on a vibration absorbing pad slightly larger than the base to minimize vibration transmission to the building structure. It is not necessary to anchor the unit to the floor.

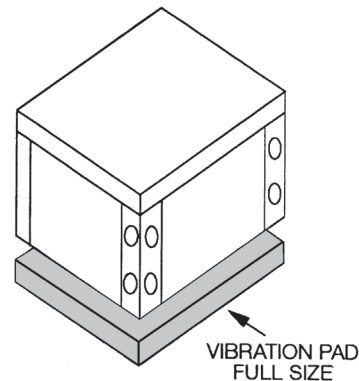

If the unit is installed on a floor over a crawl space, it should not rest on long, unsupported floor joists. Vibrations may be created in the joists with the crawl space acting as an amplifier box resulting in undesirable noise. A drain pan is recommended where water released during start-up or maintenance could cause damage below the unit.

MINIMAL SYSTEM VOLUME

FHP recommends that the total fluid volume in the system be not less than 6 gallons per nominal ton of cooling capacity.

ELECTRICAL



WARNING: Always disconnect power to the unit before servicing to prevent injury or death due to electrical shock.

All field wiring must comply with local and national fire, safety and electrical codes. Power to the unit must be within the operating voltage range indicated on the unit's nameplate. On three phase units, phases must be balanced within 2%.

Properly sized fuse or HACR circuit breakers must be installed for branch circuit protection. See equipment rating plate for maximum size. The unit is supplied with an opening for attaching conduit. Be certain to connect the ground lead to the ground lug in the control box. Connect the power leads as indicated on the unit wiring diagram.

PIPING

Supply and return piping must be as large as the unit connections on the heat pump (larger on long runs). Never use flexible hoses of a smaller inside diameter than that of the water connections on the unit. The Water-to-Water series units are supplied with either a copper or optional cupro-nickel condenser. Should your well driller express concern regarding the quality of the well water available or should any known hazards exist in your area, we recommend proper testing to assure the well water quality is suitable for use with water source equipment. In conditions anticipating moderate scale formation or in brackish water a cupro-nickel heat exchanger is recommended.



CAUTION: Galvanized pipe or fittings are not recommended for use with these units due to the possible galvanic corrosion.

Both the supply and discharge water lines will sweat if subject to low water temperature. These lines should be insulated to prevent damage from condensation.

All manual flow valves used in the system must be ball valves. Globe and gate valves must not be used due to high pressure drop and poor throttling characteristics.

Never exceed the recommended water flow rates. Serious damage or erosion of the water to refrigerant heat exchanger could occur.



CAUTION: Improper heat exchanger fluid flow due to piping, valving or improper pump operation is hazardous to the unit and constitutes abuse which will void the heat exchanger and compressor warranty.

Always check carefully for water leaks and repair appropriately. Units are equipped with female pipe thread fittings. Consult the specification sheets for sizes. Thread sealant should be used when connecting water piping connections to the units to insure against leaks and possible heat exchanger fouling. Do not overtighten the connections. Flexible hoses should be used between the unit and the rigid system to avoid possible vibration. Ball valves should be installed in the supply and return lines for unit isolation and unit flow balancing.

COOLING TOWER / BOILER APPLICATION

(Figure #1)

To assure adequate cooling and heating performance, the cooling tower and boiler fluid loop temperature should be maintained between 50° F to 100° F. In the cooling mode, heat is rejected from the unit into the condenser water loop. A cooling tower provides evaporative cooling to the loop water ; thus, maintaining a constant supply temperature to the unit. When utilizing an open cooling tower, chemical water treatment is mandatory to ensure the water is free of corrosive materials. A secondary heat exchanger (plate frame between the unit and the open cooling tower) may also be used. It is imperative that all air is eliminated from the closed loop side of the heat exchanger to prevent condenser fouling.

In the heating mode, heat is absorbed from the condenser water loop to the unit. A boiler can be utilized to maintain the loop within the proper temperature range. In milder climates a “flooded tower ” concept is often used. This concept involves adding make -up water to the cooling tower sump to maintain the desired loop temperature. No unit should be connected to the supply or return piping until the water system has been completely cleaned and flushed to remove any dirt, piping chips or other foreign material. Supply and return hoses should be connected together during this process to ensure the entire system is properly flushed. After the cleaning and flushing has taken place, the unit may be connected to the water loop and should have all valves wide open.

Pressure/temperature ports are recommended in both the supply and return lines for system flow balancing. Water flow can be accurately set by measuring the refrigerant-to- water heat exchangers water side pressure drop. See specification sheets for water flow and pressure drop information.

COOLING TOWER/BOILER APPLICATION (SOURCE SIDE)

1. BALL VALVES
2. HOSE KITS
3. P/T PLUGS
4. LOAD SIDE CONNECTIONS*
5. LOW VOLTAGE CONTROL CONNECTION*
6. VIBRATION PAD
7. LINE VOLTAGE DISCONNECT
8. SUPPLY AND RETURN LINES OF CENTRAL SYSTEM

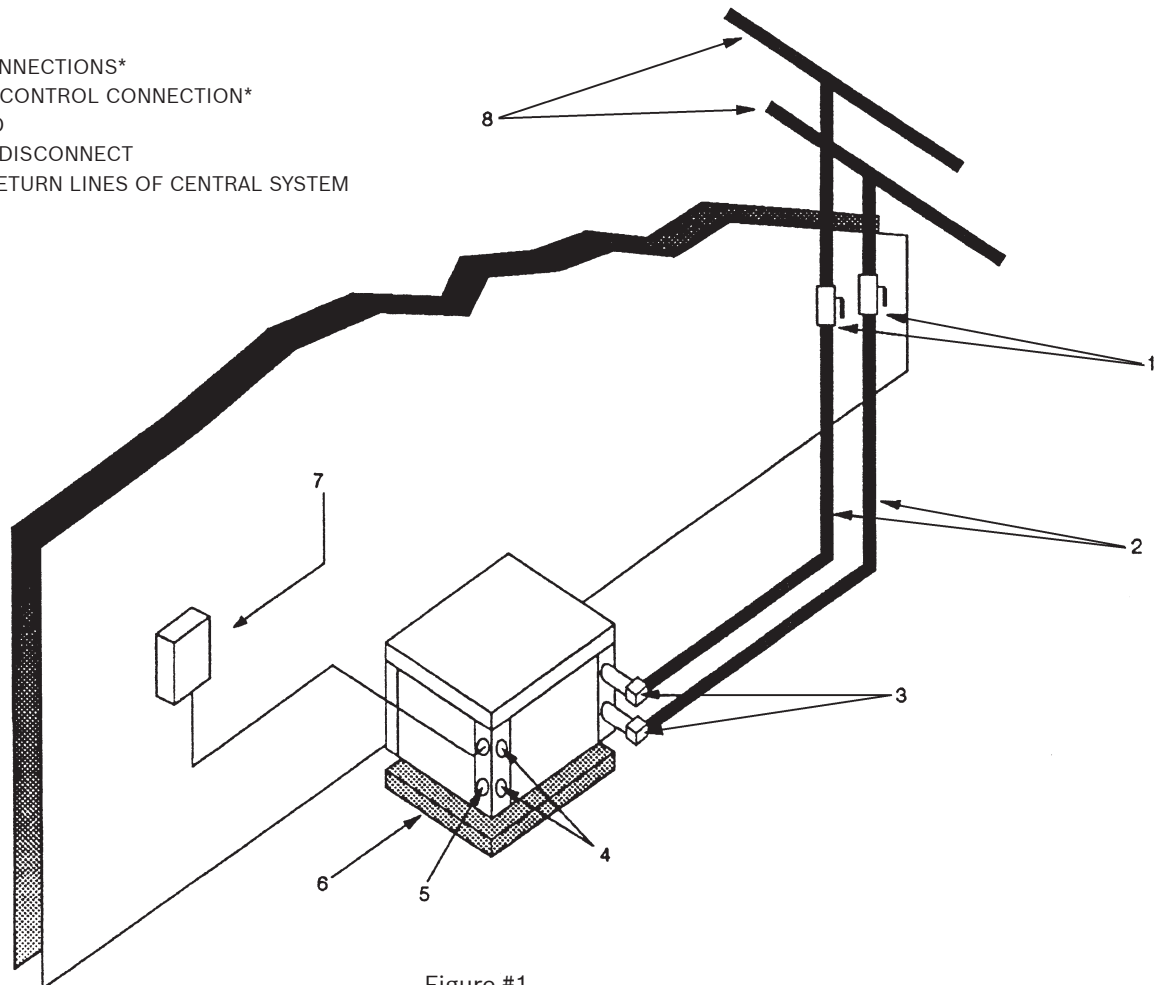

Figure #1

* NOTE: Water and electrical connection locations vary depending on model. Connect as required per unit labels.

WELL WATER SYSTEMS

(Figure #2)

Water quantity should be plentiful, between 1.5 and 2.5 gpm per ton of cooling, and of good quality. To avoid the possibility of freezing the well water should be above 50°F.

Water pressure must always be maintained in the heat exchanger by placing a water control valve on the outlet of the water-to-water unit. A bladder type expansion tank may be used to maintain pressure on the system.

Avoid using low voltage (24Volt) solenoids, using them may overload the unit transformer or interfere with the lock-out circuit. Line voltage solenoids connected across the load side (T1, T2) of the compressor contactor are preferred. Pilot operated or slow closing valves are recommended to reduce water hammer.

The discharge water from the water-to-water unit is not contaminated in any manner and can be disposed of in various ways depending on the local codes (i.e. discharge well, dry well, storm sewer, drain field, stream, pond, etc.)

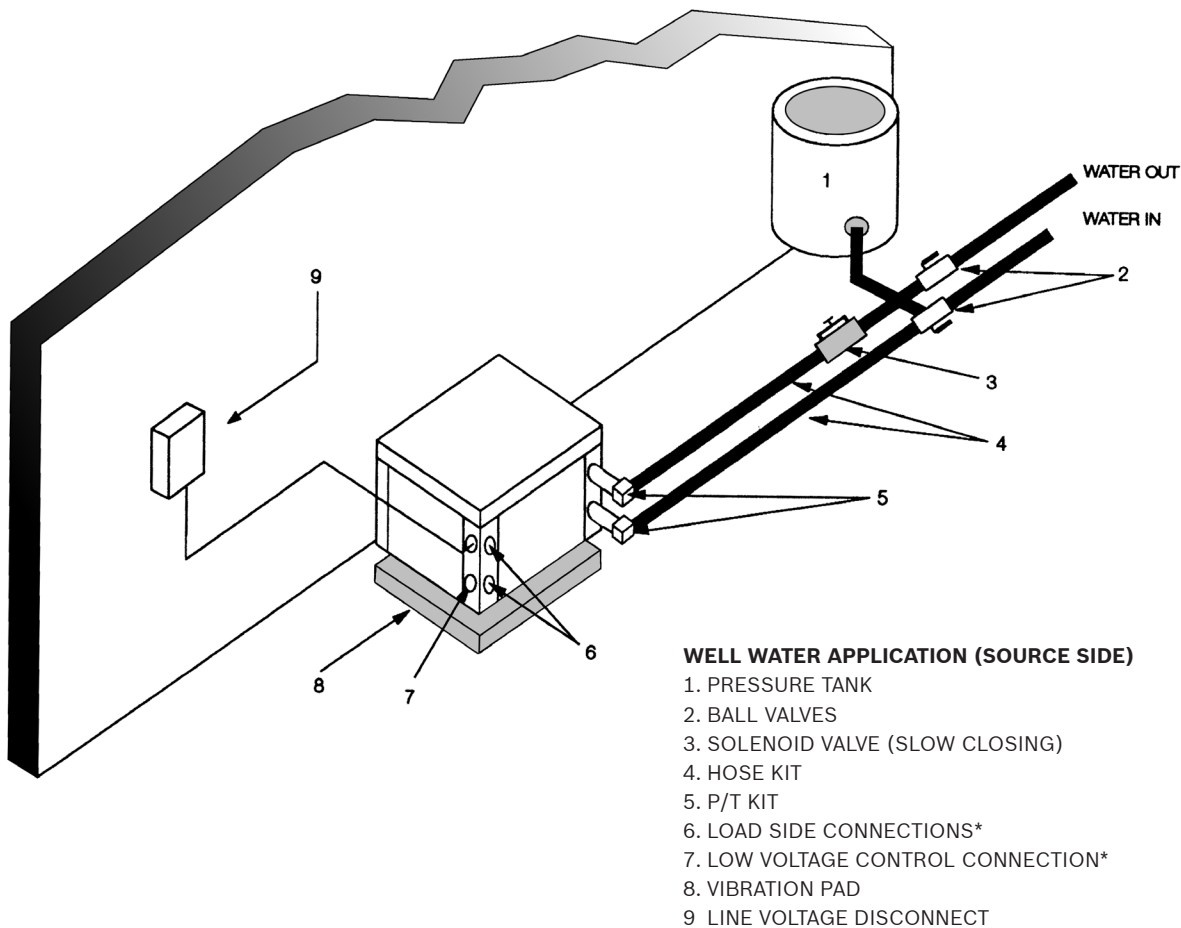

Figure #2

* NOTE: Water and electrical connection locations vary depending on model. Connect as required per unit labels.

EARTH COUPLED GEOTHERMAL SYSTEMS

(Figure #3)

Closed loop and pond applications require specialized design knowledge. No attempt at these installations should be made unless the dealer has received specialized training.

Utilizing the Ground Loop Pumping Package (GLP), makes the installation easy. Anti-freeze solutions are utilized when entering loop temperatures drop below 40°F or where piping will be routed through areas subject to freezing. A flow rate between 2.5 to 3.0 gpm per nominal ton of cooling is recommended for this application. See GLP Pump Curve for sizing information.

TYPICAL LOAD SIDE APPLICATIONS

There are many load side applications for which the water- to-water heat pump/ liquid chiller is ideally suited.

SOME TYPICAL USES ARE AS FOLLOWS

Hydronic baseboard heating, hydronic in-slab floor heating, forced air fan coil heating or cooling, ice and snow melting, heating potable water, (when allowed by code) heating swimming pool and spa*, process fluid heating or cooling.

When specifying load side fluid volume it is important to consider the heat pump output capacities and flow rates. Insufficient load side fluid volume may cause unstable heat pump operation. (short cycling) Pressure/ temperature ports should be used to set flow rates.



NOTE: A water-to-water series Heat Pump/ Liquid Chiller can be utilized for direct pool/spa heating without a secondary heat exchanger. In this application cupro-nickel heat exchangers must be used. Automatic chemical feeders must never be installed up stream of the unit. An external bypass should be installed to avoid over-flowing the heat exchanger to prevent coil erosion. The pool pH levels and chemical balances must be maintained to avoid possible heat exchanger damage.

EARTH COUPLED APPLICATION (SOURCE SIDE)

1. POLYBUTYLENE OR POLYETHELENE WITH INSULATION
2. GROUND LOOP PUMPING PACKAGE (GLP)
3. GROUND LOOP CONNECTION KIT
4. P/T PLUGS
5. LOAD SIDE CONNECTIONS*
6. LOW VOLTAGE CONTROL CONNECTION*
7. VIBRATION PAD
8. LINE VOLTAGE DISCONNECT

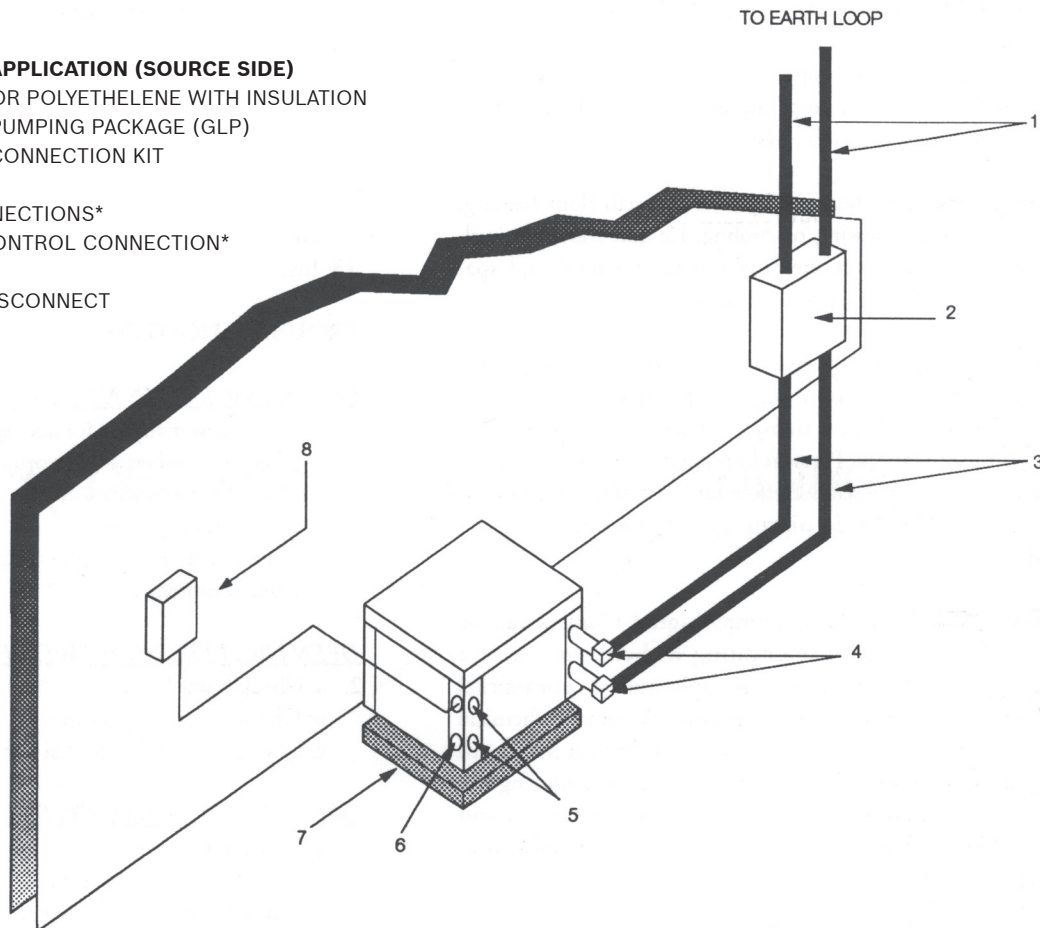

Figure #3

* NOTE: Water and electrical connection locations vary depending on model. Connect as required per unit labels.

SAFETY DEVICES AND THE UPM CONTROLLER

Each unit is factory provided with a Unit Protection Module (UPM) that controls the compressor operation and monitors the safety controls that protect the unit.

Safety controls include the following:

- High pressure switch located in the refrigerant discharge line and wired across the HPC terminals on the UPM
- Low pressure switch located in the unit refrigerant suction line and wired across terminals LPC1 and LPC2 on the UPM.
- Optional freeze protection sensor, mounted close to condensing water coil, monitors refrigerant temperature between condensing water coil and thermal expansion valve. If temperature drops below or remains at freeze limit trip for 30 seconds, the controller will shut down the compressor and enter into a soft lockout condition. The default freeze limit trip is 30°F, however this can be changed to 15°F by cutting the R42 resistor located on top of DIP switch SW1.
- The optional condensate over flow protection sensor (standard on horizontal units) is located in the drain pan of the unit and connected to the 'COND' terminal on the UPM board.

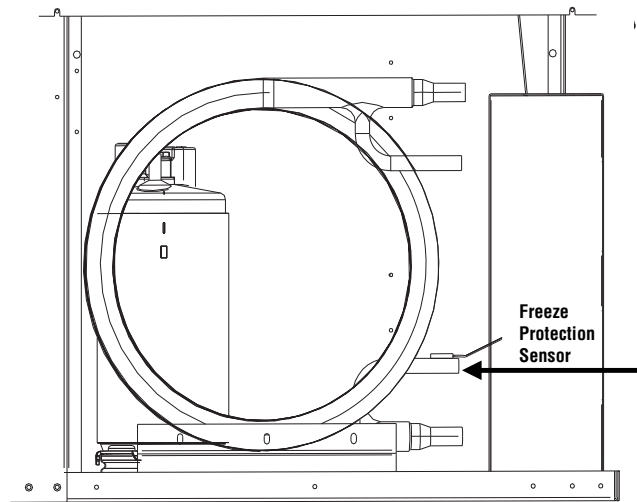

Freeze Protection Sensor



NOTE: If freeze protection sensor is not installed, a jumper between freeze contacts must be installed on the UPM board otherwise unit will not start.

The UPM includes the following features:

- **ANTI-SHORT CYCLE TIME**—5 minute delay on break timer to prevent compressor short cycling.
- **RANDOM START**—Each controller has a unique random start delay ranging from 270 to 300 seconds to reduce the chances of multiple units simultaneously starting after initial power up or after a power interruption, creating a large electrical spike.
- **LOW PRESSURE BYPASS TIMER**—If the compressor is running and the low pressure switch opens, then the control will keep the compressor on for 120 seconds. After 2 minutes if the low pressure switch remains open, the control will shut down the compressor and enter a soft lockout. The compressor will not be energized until the low pressure switch closes and the anti-short cycle time delay expires. If the low pressure switch opens 2–4 times in 1 hour, the unit will enter a hard lock out and need to be reset.
- **BROWNOUT/SURGE/POWER INTERRUPTION PROTECTION**—The brownout protection in the UPM board will shut down the compressor if the incoming power falls below 18 VAC. The compressor will remain off till the voltage goes above 18 VAC and the anti short cycle timer (300 seconds) times out. The unit will not go into a hard lockout.
- **MALFUNCTION OUTPUT**—Alarm output is Normally Open (NO) dry contact. If 24 VAC output is needed R must be wired to the ALR-COM terminal; 24VAC will be available on the ALR-OUT terminal when the unit is in alarm condition. If pulse is selected the alarm output will be pulsed. The fault output will depend

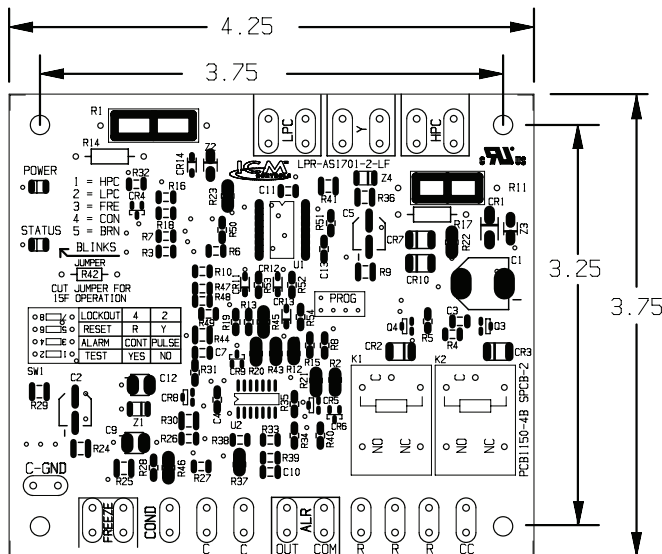

on the dip switch setting for “ALARM”. If it set to “CONST”, a constant signal will be produced to indicate a fault has occurred and the unit requires inspection to determine the type of fault. If it is set to “PULSE”, a pulse signal is produced and a fault code is detected by a remote device indicating the fault. See L.E.D. Fault Indication below for blink code explanations. The remote device must have a malfunction detection capability when the UPM board is set to “PULSE”.

- **TEST DIP SWITCH**—A test dip switch is provided to reduce all time delay settings to 10 seconds during troubleshooting or verification of unit operation. Note that operation of the unit while in test mode can lead to accelerated wear and premature failure of the unit. The “TEST” switch must be set back to “NO” for normal operation.
- **FREEZE SENSOR**—The freeze sensor input is active all the time, if a freeze option is not selected the freeze terminals will need a jumper. There are 2 configurable freeze points, 30°F & 15°F. The unit will enter a soft lock out until the temperature climbs above the set point and the anti-short cycle time delay has expired. The freeze sensor will shut the compressor output down after 90 seconds of water flow loss and report a freeze condition. It is recommended to have a flow switch to prevent the unit from running if water flow is lost.



NOTE: If unit is employing a fresh water system (no anti-freeze protection), it is extremely important to have the “Freeze” jumper R42 resistor set to 30°F in order to shut down the unit at the appropriate leaving water temperature and protect your heat pump from freezing if a freeze sensor is included.

- **L.E.D. FAULT INDICATION**—Two L.E.D. indicators are provided:
- Green: Power L.E.D. indicates 18–30 VAC present at the board.
- Red: Fault indicator with blink codes as follows:
 - One blink—High pressure lockout
 - Two blinks—Low pressure lockout
 - Three blinks—Freeze sensor lockout
 - Four blinks—Condensate over flow
 - Five blinks—Brownout
- **INTELLIGENT RESET**—If a fault condition is initiated, the 5 minute delay on break time period is initiated and the unit will restart after these delays expire. During this period the fault LED will indicate the cause of the fault. If the fault condition still exists or occurs 2 or 4 times (depending on 2 or 4 setting for Lockout dip switch) before 60 minutes, the unit will go into a hard lockout and requires a manual lockout

reset. A single condensate overflow fault will cause the unit to go into a hard lockout immediately, and will require a manual lockout reset.

- **LOCKOUT RESET**—A hard lockout can be reset by turning the unit thermostat off and then back on when the “RESET” dip switch is set to “Y” or by shutting off unit power at the circuit breaker when the “RESET” dip switch is set to “R”.



NOTE: The blower motor will remain active during a lockout condition.

- **UPM BOARD DEFAULT SET TINGS**—Your UPM board will come from the factory with the following default settings:
 - **Freeze**—“Terminals not jumped” on all the time
 - **Temp**—30°F
 - **Lockout**—2
 - **Reset**—“Y”
 - **Alarm**—“PULSE”
 - **Test**—“NO”
 - **Dr y Contact**—“Normally Open (NO)”

CONSIDERATIONS

1. Always check incoming line voltage power supply and secondary control voltage for adequacy. Transformer primaries are dual tapped for 208 and 230 volts. Connect the appropriate tap to ensure a minimum of 18 volts secondary control voltage. 24 volts is ideal for best operation.
2. Long length thermostat and control wiring leads may create voltage drop. Increase wire gauge or up-size transformers may be required to insure minimum secondary voltage supply.
3. FHP recommends the following guidelines for wiring between a thermostat and the unit: 18 GA up to 60 foot, 16 GA up to 100 ft and 14 GA up to 140 ft.
4. Do not apply additional controlled devices to the control circuit power supply without consulting the factory. Doing so may void equipment warranties.
5. Check with all code authorities on requirements involving condensate disposal/over flow protection criteria.

SEQUENCE OF OPERATION

Cooling Mode

See Typical Wiring Diagram page 24. Energizing the “O” terminal energizes the unit reversing valve in the cooling mode. The fan motor starts when the “G” terminal is energized.

UPM SEQUENCE OF OPERATION (SOO) FLOW CHART

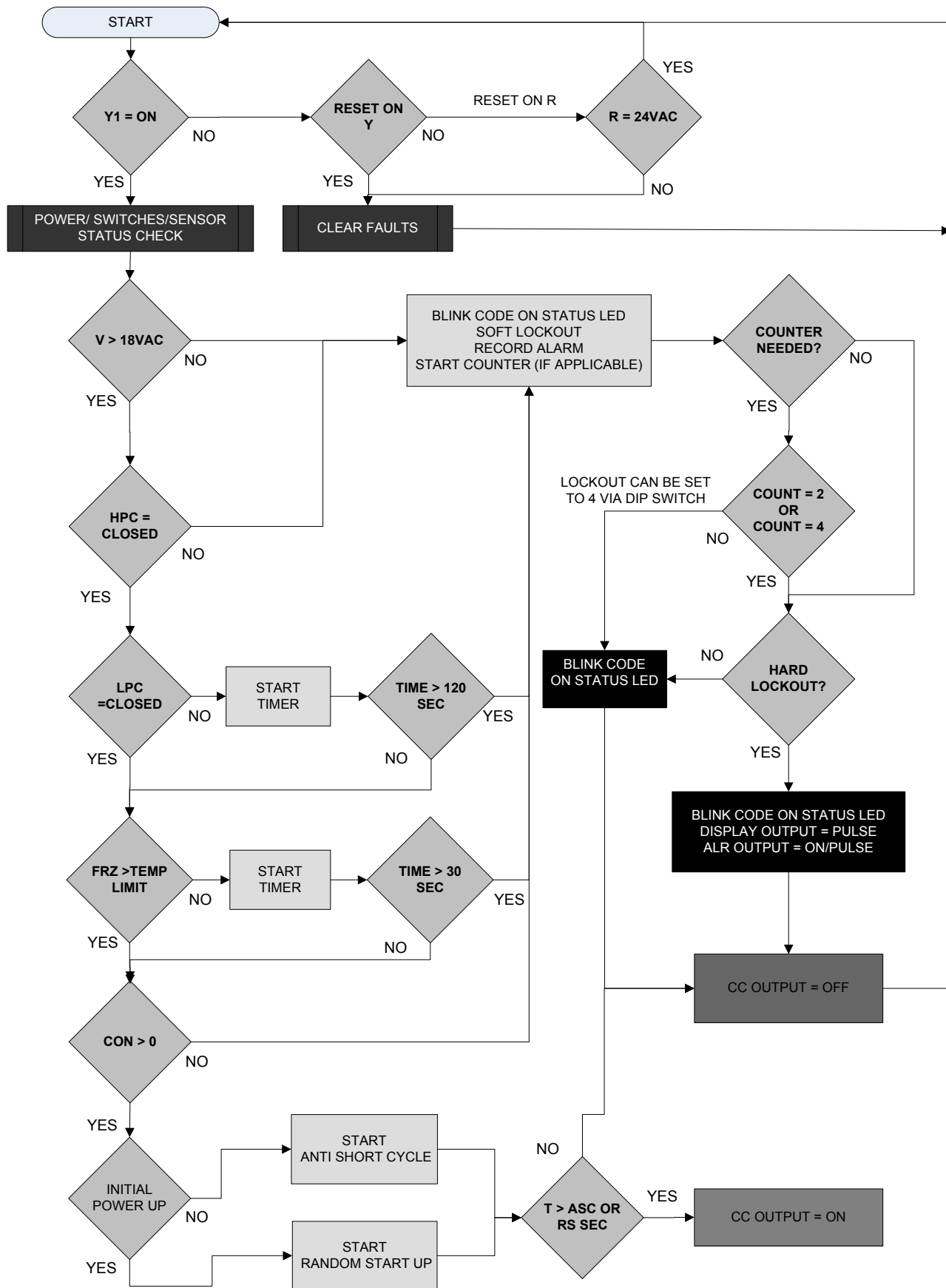

When the thermostat calls for cooling (Y), the loop pump or solenoid valve if present is energized and compressor will start.

Once the thermostat is satisfied, the compressor shuts down accordingly and the fan ramps down to either fan only mode or off over a span of 30 seconds (ECM Motors).



Note that a fault condition initiating a lockout will de-energize the compressor.

Heating Mode

Heating operates in the same manner as cooling, but with the reversing valve de-energized. The compressor will run until the desired setpoint temperature on the thermostat is achieved.

Once the thermostat is satisfied, the compressor shuts down and the fan ramps down in either fan only mode or turns off over a span of 30 seconds. Auxiliary electric heating coils are not available on the AP product line.

WATER TO WATER UNIT CONTROLLER (OPTIONAL)

FHP’s newly developed water to water heat pump controller offers a low cost, simple solution to the control of a water to water heat pump unit. The control is configurable to provide cooling only, heating only or auto change over control strategies based on the application of the unit in a given system.

FEATURES

- Selectable mode of operation. Cooling, Heating or Auto Changeover.
- Adjustable temperature differential for heating and cooling set point.
- Adjustable auto changeover set point with adjustable dead band setting.
- Intelligent auto reset of a fault condition avoids nuisance hard lockouts.
- LED display of control temperature and set points.
- °F or °C Display.
- 50\60 Hertz operation.
- Pump operation configurable for continuous or cycling operation with the compressor.
- Compressor lead-lag operation on units with dual compressors.
- Malfunction output and service LED can be set to steady or pulsing to indicate fault condition.
- Color LED’s indication of mode of operation.
- Set points retention in non volatile memory in the event of a power failure.

- Five minute delay on break or power interruption for compressor short cycling protection.
- Brown out low voltage protection

All of the unit’s safeties are tied back into the controller for system protection.

UNIT SENSORS

The unit controller is provided with two sensors:

Water Sensor: This sensor will control unit operation in the cooling or heating mode based on the water temperature. It may be field mounted for example on the return water line or in a water tank when provided with a field supplied immersion well. The location will depend on the specific requirements of the job.

Changeover Sensor: This sensor will put the unit in either the heating or cooling mode depending on the set point. It may be mounted in a location that would be indicative if the unit should be in either the heating or cooling mode, for example outdoors. The sensor may be located up to 1000 feet from the unit (additional field supplied wiring required).

MODES OF OPERATION

The controller will memorize the last mode used before power is removed and will run in that mode after it is turned on. In all modes the control will display temperature degree differential setting for five seconds once it is powered and this setting may be adjusted during this time. Thereafter the display will switch to the monitored water temperature. When switching from one mode to another the set point (the decimal point is used to distinguish it from water temperature) for the new mode is displayed for

5 seconds and then monitored water temperature. During this time the set point may be adjusted.

OFF MODE

In the OFF mode all outputs are disabled and mode indication LED’s will be off.

The control will first display temperature differential setting with the ability for the user to adjust it and then will display “OFF” and finally water temperature.

HEATING MODE

BLINK CODE	FAULT CONDITION
One blink	High pressure circuit 1
Two blinks	Low pressure circuit 1
Three blinks	High pressure circuit 2
Four blinks	Low pressure circuit 2

When the unit is operated in the heating mode and the controlled water temperature is below the set point minus the differential setting, terminal Y1 will close and the unit will operate (first stage compressor in a two stage unit). When the set point is satisfied the compressor is turned off.

In a two stage unit after the first stage activation if the water temperature drops an additional two degrees below the set point, the second stage (terminal Y2) will be activated (if control is configured for both compressors). Both stages will be on until the set point is satisfied.

When the unit runs after power is applied or the mode is changed from cooling to heating, if the fluid temperature is below set point and doesn't change for 3 minutes, the second stage of heating will be activated. This only applies for a two stage machine.

There will be 5 minutes delay on break after the unit cycles off on temperature, a power interruption or because of a fault condition. At any point in time the control will ignore a low pressure switch condition for 120 seconds before turning off the compressor.

COOLING MODE

When the unit is operated in the cooling mode and the leaving water temperature is above the temperature set point plus the differential setting, terminals Y1 will close (first stage compressor of a two stage unit) and the unit will operate in the cooling mode. When the set point is satisfied the compressor is turned off. The reversing valve is always activated when the unit is in the cooling mode.

On two stage units, after first stage activation if water temperature increases two degrees above the set point, the second stage (terminal Y2) will be activated (if control is configured for both compressors). Both stages will remain on until the set point is satisfied.

When the unit runs after power is applied or the mode is changed from heating to cooling, if the fluid temperature is above cooling point and doesn't change for 3 minutes, the second stage will be activated. This only applies for a two stage machine.

There will be 5 minutes delay on break after the unit cycles off on temperature, a power interruption or because of a fault condition.

AUTO CHANGEOVER MODE

In the auto changeover mode control will switch from the heating mode to cooling mode and vice versa based on the setting of the change over sensor. There will be a dead-band where the control will not call for either heat or cool. The dead-band setting is adjustable in the configuration mode. When the auto changeover mode is selected the changeover set point will be displayed for 5 seconds however this set point is only adjustable when the controller is in the configuration mode. Once the control has switched to either the heating or cooling

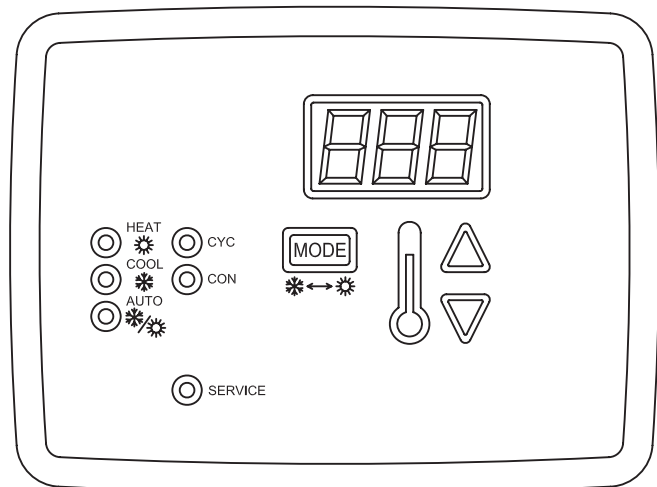

mode, pressing the Up or Down buttons will display the set point for that particular mode.

When the reading from the changeover sensor is above the changeover set point plus the dead-band setting, the unit will operate in the cooling mode and will maintain the cooling set point temperature. While in the cooling mode the user can adjust the cooling set point. Likewise when the changeover sensor is below the changeover set point minus the dead-band setting, the unit will switch to the heating mode and will maintain the heating set point temperature. While in the heating mode the user can adjust the heating set point.

Once the reading from the sensor enters the dead-band zone it will terminate the call for cooling or heating even if the set points are not satisfied.

The controller will ignore the Auto changeover mode and set points when the changeover sensor (sensor S2) is shorted. Mode switching will be HEAT – COOL – OFF in a closed loop. If the changeover sensor is shorted when the control is in Auto changeover mode then the control will switch to the OFF mode. If no sensor is connected the controller will indicate a sensor error code.

UNIT PROTECTION

The unit controller will protect the unit against a high or low pressure condition and brownout. To avoid nuisance lockouts an intelligent reset function is built into the controller to allow the unit to restart one time in the event of a fault condition.

If a fault condition is initiated on any circuit the corresponding compressor will be turned off and the 5 minute delay on break time period timer is initiated. After the delay expires the unit will attempt to restart. If the fault condition still exists or reoccurs within the next 60 minutes, the unit will go into a hard lockout and requires a manual lockout reset. During this period the fault LED will indicate the cause of the fault.

A 120 second time delay is built into the low pressure switch to avoid nuisance trips with low fluid temperatures.

MODE	INDICATION
	HEAT Red LED to indicate that the control is in the HEATING mode
COOL	Green LED to indicate that the control is in the COOLING mode
AUTO	Yellow LED to indicate that the control is in AUTO mode
CON	Red LED to indicate that pump(s) are selected for continuous operation
CYC	Red LED to indicate that pump(s) are selected for cycling operation
SERVICE	Red LED will turn steady on or blink to indicate that a pressure switch has opened

SETTING	RANGE	DEFAULT
Temp Setting	40-120° F Heating and Cooling	
Differential	1-3°F DEGREES	1°F
Mode	HEAT, COOL, AUTO, OFF	OFF
Temp Scale	F, C	F
Pump Mode	con (continuous), cyc (cycle)	con
Dead Band	1-6°F DEGREES	3°F
Auto Change Over	55-85°F	65°F
Test Mode	De (delay), or Nd (No delay)	De
Compressor	Si (Single), Du (Dual)	Si
Lead Lag	0 - 14 Days	0
Malfunction	St (steady), Pu (pulsing)	St

While in a soft lockout condition the display will show the specific fault (for example LP1) and the “service” LED will turn on according to the malfunction mode. If the setting for malfunction mode is “steady,” the service LED will turn and remain on. If the setting is “pulse,” the service LED will blink according to the blink code as follows:

BROWNOUT PROTECTION

The control will disable all outputs if the supply voltage drops below 17 VAC. The outputs will be enabled if the supply voltage rises and remains above 17 VAC for the 5 minutes time delay. During that time control will display “bro.”

MANUAL LOCKOUT

The unit or refrigeration circuit will go into a manual lockout if the HPS or LPS opens (LPS open more than 120 seconds each time) twice within one hour.

During manual lockout the compressor(s) is turned off and locked out and the display will show the fault (for example LP1) and the “service” LED “malfunction” output will either be steady or blink according to the malfunction mode as described above.

If selection for compressor is “Du” (see configuration) and one compressor has locked out, the control will switch the call to the other compressor. If compressor setting is “Si”, the control shall not switch the call to the other compressor.

To reset a unit after a hard lockout the user needs to recycle power or switch the controller to the OFF mode.

LEAD -LAG

The Controller has the capability to lead-lag compressors on a dual compressor unit.

The lead-lag between the compressors is active only when both compressors are in use (and the compressor setting is “Du”).

When the setting for lead-lag is other than 00, compressor setting is “Du” and one compressor has locked out; control will switch the call to the other compressor and stop the timing for lead-lag. The lead lag setting remains in the memory

If control has called for the second stage three times in a row, and compressor setting is “Du”; regardless of the lead- lag setting control will switch the call to the other compressor. The lead-lag timer is reset and the lead-lag setting still applies.

PUMP CYCLING

When ordered with the optional pump relay the controller will cycle either the load, source or both pumps with the compressor operation. Please see the typical wiring diagram for details.

OPERATING INSTRUCTIONS

USER INTERFACE

The following parameters are displayed on the screen:

- Control fluid temperature when in normal mode
- Settings within the configuration mode
- Individual operating mode temperature set points
- Fault display

UP BUTTON

- Press once to display the current set point temperature.
- After current set point temperature is displayed, pressing again will increment the set point 1 degree for every push. Pressing and holding the up button will increment the set point at a rate of 4 degrees per second.
- When pressed with the down arrow for 5-seconds, the control will display the current temperature scale (Fahrenheit or Celsius).
- Used to change the settings for: temperature scale, dead band, test mode, initial delay, compressor, pump, and malfunction settings.

DOWN BUTTON

- Press once to display the current set point temperature.
- After current set point temperature is displayed, pressing again will decrement the set point 1 degree for every push. Pressing and holding the down button will decrement the set point at a rate of 4 degrees per second
- When pressed with the up arrow for 5- seconds, the control will display the current temperature scale (Fahrenheit or Celsius).
- Used to change the settings for: temperature scale, dead band, test mode, initial delay, compressor, pump, and malfunction settings.

LED INDICATORS USER ADJUSTABLE SETTINGS CHART

SETTING UP THE CONTROLLER

On unit power up the LED display will show the software version, temperature differential setting with the ability for the user to change it for ten seconds then will display "OFF" and then finally will display the control temperature of the fluid being measured (entering fluid, leaving fluid, tank, etc.) The default setting of the differential is 1 degree F and can be adjusted from 1 – 3 degrees F at start up.

The differential setting is the differential between set point temperature and actual on/off temperature of the machine.

For example:

Cooling set point = 45°F
Differential = 1°F

The heat pump will cycle on in cooling at 46°F. If a two stage machine, stage 2 will come on at 48°F or 2°F degrees above set point and one degree differential. The unit will shut off at set point.

Heating set point = 120°F
Differential = 1°F

Stage one will come on at 119°F and stage 2 will come at 117°F. Both stages will remain running until set point is achieved. Stage 1 and stage 2 will cycle on and off according to the lead/lag programmed interval.

Whenever there is a demand for heating and cooling and during the first stage of operation the temperature isn't changing, then the control will activate the second stage after a three minute delay from the first stage activation. This logic will apply when the control is powered up, on a power interruption, when the mode function is set to OFF and then back to either HEAT or COOL and when switching from heating to cooling or vice versa in the auto changeover mode.

Heating and cooling set points are adjusted by selecting each mode on the key pad and then using the up-down

arrows to select the set point. Thus, push cool mode button and use down arrow to 45°F. Push heat mode button and use up arrow to 120°F.

The controller can be set to control heating only, cooling only, or auto change modes. The mode button is pushed until the circular LED is lit next to the chosen control mode.



CAUTION: If the change over (S2) sensor terminals are shorted (jumped) auto changeover mode is disabled. If the auto changeover sensor terminals are not connected the controller will show a sensor error.

INITIAL CONFIGURATION

After power up and the steps above are completed the configuration default settings may be changed. Holding down the up and down arrow buttons simultaneously for 10 seconds will put the controller into the configuration mode. This mode will be exited if no other commands are given within a 10 second period.

Please review all the following steps and enter the values you want to set at each display field to avoid a time out period while configuring. This will also provide a record of the initial configuration settings.

FIRST DISPLAY FIELD:

Temperature scale OC or OF. This is selectable by using the up or down arrows. Once selected hit "mode" key to advance.

Scale: _____

SECOND DISPLAY FIELD

Pump operation: Continuous or cyclic. This is the load or source or both pumps output relay. This may be set to continuous pump or cyclic pump mode to cycle with the compressor by using the up or down arrows. Once selected hit "mode" key to advance.

Mode: _____

THIRD DISPLAY FIELD

Change over dead band setting: This is selectable from 1 to 6 degrees. This is adjustable from 1-6 degrees by using the up or down arrows. The dead band setting is only used in the auto change mode and defines the band where the unit will not operate. This helps eliminate the possibilities of the unit cycling from one mode to the other too quickly. For example, on a heating/cooling residential application this could be set as wide as 6 degrees. On a pool heater application this could be set as tight as 1 degree. Once selected hit the "mode" key to advance.

Value: _____

FOURTH DISPLAY FIELD:

Auto change over set point (S2). Adjustable from 55 to 85 degrees. Use up or down arrows to adjust. Hit the “mode” key to advance. The auto changeover sensor should be located in an area that will be indicative of whether the unit should be in the heating or cooling mode.

Value: _____

FIFTH DISPLAY FIELD:

Test mode setting, (DE) delay or (ND) no delay: This is utilized for testing the outputs of the controller by eliminating the time delays. Use the up or down arrows to select. The controller will automatically revert to DE after one cycle to insure safety timings are restored if installer/commissioner forgets to reset to DE. The ND setting could be selected at start-up to avoid prolonged waiting periods during commissioning.

Once selected hit the “mode” key to advance.

Setting: _____

SIXTH DISPLAY FIELD:

Compressor setting, (Si) single or (Du) dual. Use the up or down arrows to select. Hit the “mode” key to advance. This is only applicable on multi stage units. If set to Si on a dual circuit unit the second stage will not come on.

Setting: _____

SEVENTH DISPLAY FIELD:

Lead/lag setting (dual compressor only). Set point is 0 to 14 days on lead compressor rotation sequence. Use up or down arrows to select. Hit “mode” key to advance.

Setting: _____

EIGHTH DISPLAY FIELD:

Malfunction output setting, (Pu) pulsed or (St) standard constant on. This sets the malfunction output relay to mimic the fault blink code that is causing the safety lock-out. This can be used for remote monitoring and remote trouble shooting. Use the up or down arrows to select. Hit the “mode” key to advance.

Setting: _____

The controller is now configured and is fully operational.

A copy of this configuration sheet should be left with the home owner or building manager for their records of initial control settings.

SYSTEM CHECKOUT

After completing the installation, and before energizing the unit, the following system checks should be made:

- Verify that the supply voltage to the unit is in accordance with the nameplate ratings.

- Make sure that all electrical connections are tight and secure.
- Check that the field wiring and the electrical fusing are the correct size.
- Verify that the low voltage wiring between the primary controller and the unit is correct.
- Verify that the water piping is complete and correct.
- Check that the water flow is correct, adjust if necessary.
- Verify that vibration isolation has been provided.
- Be certain that the unit is serviceable, and all access panels are secured in place.

UNIT START-UP

1. Set the primary controller to the highest setting.
2. Set the primary controller system switch to “COOL”. The reversing valve solenoid should energize. The compressor should not run.
3. Reduce the primary controller setting approximately 5 degrees below return fluid temperature.
4. Verify the heat pump is operating in the cooling mode.
5. Check the cooling refrigerant pressures against the values listed in Table #3 for WW Units.
6. Turn the primary controller system switch to the “OFF” position. The unit should stop running and the reversing valve should de-energize.
7. Leave the unit off for approximately (5) minutes to allow for system equalization.
8. Turn the primary controller to the lowest setting.
9. Set the primary controller switch to “HEAT”.
10. Increase the primary controller setting approximately 5 degrees above the return fluid temperature.
11. Verify the heat pump is operating in the heating mode.
12. Check the heating refrigerant pressures against the values listed in Table #4 for WW.
13. Set the primary controller to maintain the desired return fluid temperature.
14. Check for vibrations, leaks, etc...
15. Instruct the owner on the unit and control operation.

14

CHILLER MODE

COOLING MODE OPERATING PRESSURES (PSIG)

ENTERING LOAD/EVAP TEMP. °F.	ENTERING SOURCE CONDENSER TEMPERATURE DEG. F.					
	75°F		85°F		95°F	
	SUCTION PRESSURE	DISCHARGE PRESSURE	SUCTION PRESSURE	DISCHARGE PRESSURE	SUCTION PRESSURE	DISCHARGE PRESSURE
65	99-116	290-320	107-123	325-358	107-123	370-400
55	91-107	265-311	91-107	303-350	99-116	370-400
45	76-91	265-311	76-91	295-345	83-99	358-390

TABLE #3 – WT/WW R410A Units

BOILER MODE

HEATING MODE OPERATING PRESSURES (PSIG)

ENTERING LOAD DEG. °F.	ENTERING SOURCE	SUCTION PRESSURE	DISCHARGE PRESSURE
70	0	68-83	255-290
	60	99-116	270-305
	80	130-145	290-325
90	40	76-91	350-380
	60	99-116	358-390
	80	130-165	370-400
110	40	76-91	455-480
	60	99-116	470-500
	80	139-165	480-575

TABLE #4 – WT/WW R410A Units

NOTE: Above ratings are based on water flow rates stated in specification sheets. 2.4 GPM/ton on evaporator side and 10°F Δ T on condenser side when in the chiller mode. Boiler mode conditions are 2.4 GPM/ton on the source side and 10°F Δ T on load side. The values are typical and may vary between models.

WIRING DIAGRAM

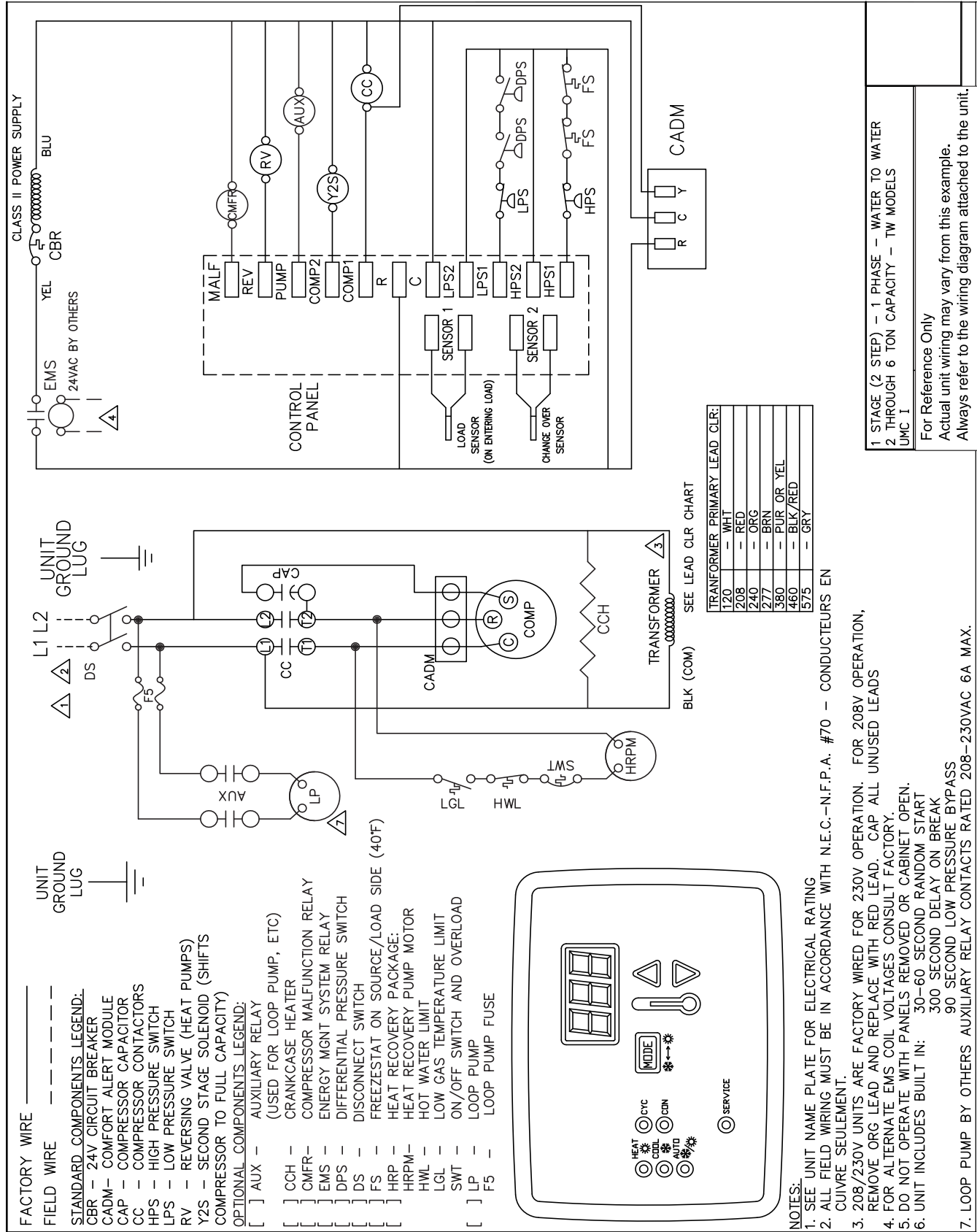

1. STAGE (2 STEP) — 1 PHASE — WATER TO WATER
 2. THROUGH 6 TON CAPACITY — TW MODELS UMC 1
- For Reference Only
 Actual unit wiring may vary from this example.
 Always refer to the wiring diagram attached to the unit.

- FACTORY WIRE** ———
FIELD WIRE - - - - -
- STANDARD COMPONENTS LEGEND:**
 CBR — 24V CIRCUIT BREAKER
 CADM — COMFORT ALERT MODULE
 CAP — COMPRESSOR CAPACITOR
 CC — COMPRESSOR CONTACTORS
 HPS — HIGH PRESSURE SWITCH
 LPS — LOW PRESSURE SWITCH
 RV — REVERSING VALVE (HEAT PUMPS)
 Y2S — SECOND STAGE SOLENOID (SHIFTS COMPRESSOR TO FULL CAPACITY)
- OPTIONAL COMPONENTS LEGEND:**
 [] AUX — AUXILIARY RELAY (USED FOR LOOP PUMP, ETC)
 [] CCH — CRANKCASE HEATER
 [] CMFR — COMPRESSOR MALFUNCTION RELAY
 [] EMS — ENERGY MGMT SYSTEM RELAY
 [] DPS — DIFFERENTIAL PRESSURE SWITCH
 [] DS — DISCONNECT SWITCH
 [] FS — FREEZE/STAT ON SOURCE/LOAD SIDE (40°F)
 [] HRP — HEAT RECOVERY PACKAGE
 [] HRPM — HEAT RECOVERY PUMP MOTOR
 [] HWL — HOT WATER LIMIT
 [] LGL — LOW GAS TEMPERATURE LIMIT
 [] SWT — ON/OFF SWITCH AND OVERLOAD
 [] LP — LOOP PUMP
 [] F5 — LOOP PUMP FUSE

- NOTES:**
1. SEE UNIT NAME PLATE FOR ELECTRICAL RATING
 2. ALL FIELD WIRING MUST BE IN ACCORDANCE WITH N.E.C.—N.F.P.A. #70 — CONDUCTEURS EN CUIVRE SEULEMENT.
 3. 208/230V UNITS ARE FACTORY WIRED FOR 230V OPERATION. FOR 208V OPERATION, REMOVE ORG LEAD AND REPLACE WITH RED LEAD. CAP ALL UNUSED LEADS
 4. FOR ALTERNATE EMS COIL VOLTAGES CONSULT FACTORY.
 5. DO NOT OPERATE WITH PANELS REMOVED OR CABINET OPEN.
 30-60 SECOND RANDOM START
 300 SECOND DELAY ON BREAK
 90 SECOND LOW PRESSURE BYPASS
 7. LOOP PUMP BY OTHERS AUXILIARY RELAY CONTACTS RATED 208-230VAC 6A MAX.

WIRING DIAGRAM

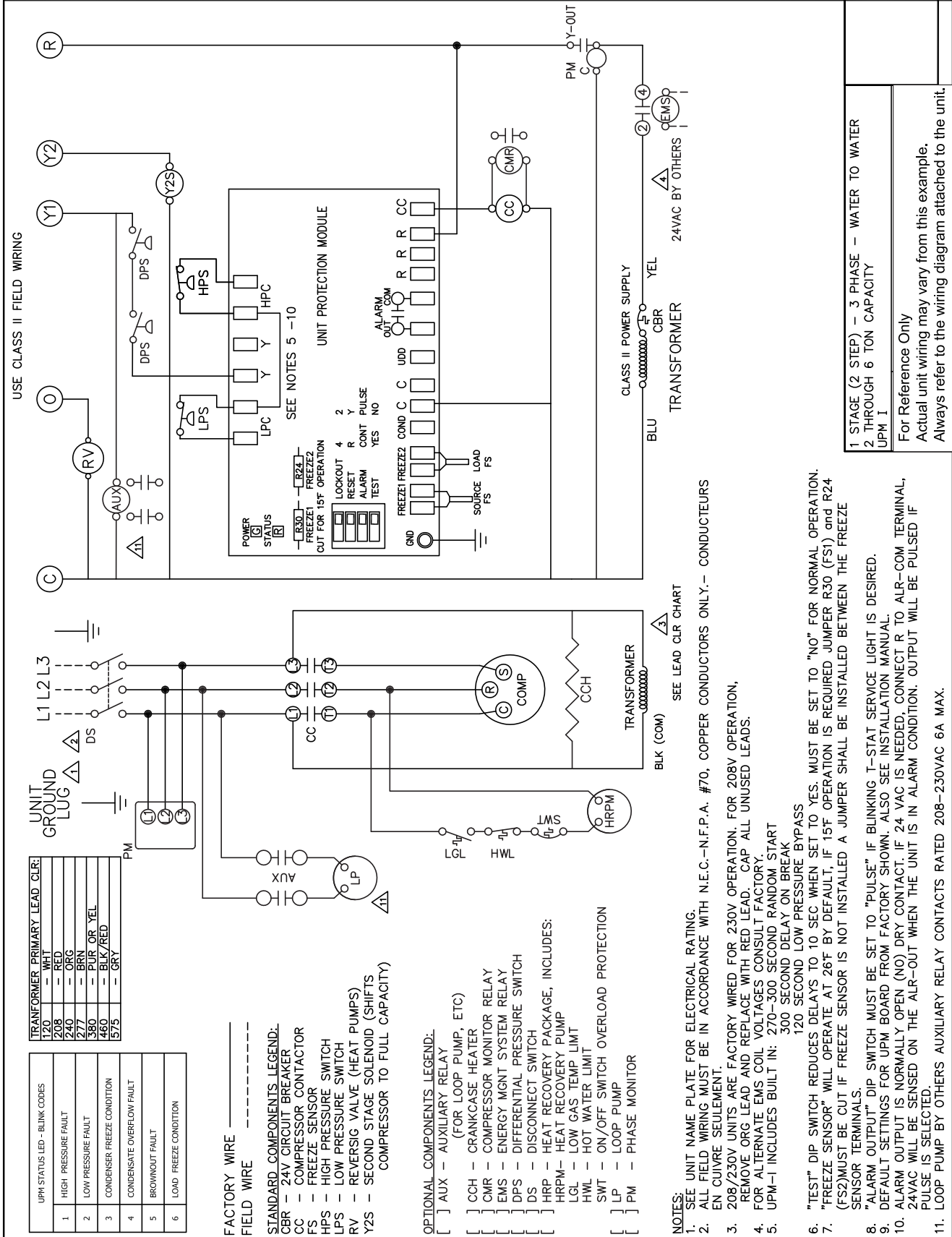

WIRING DIAGRAM

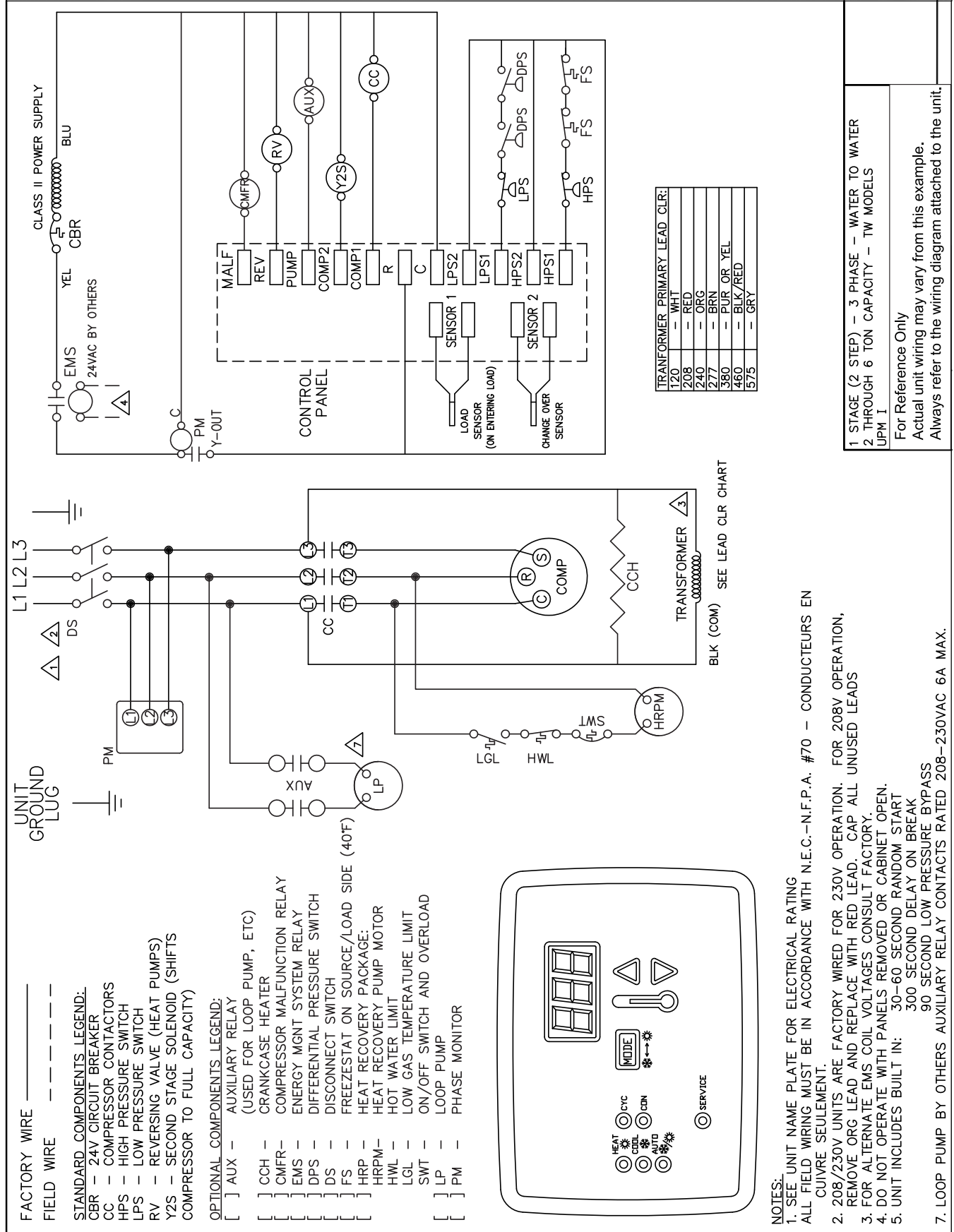

WIRING DIAGRAM

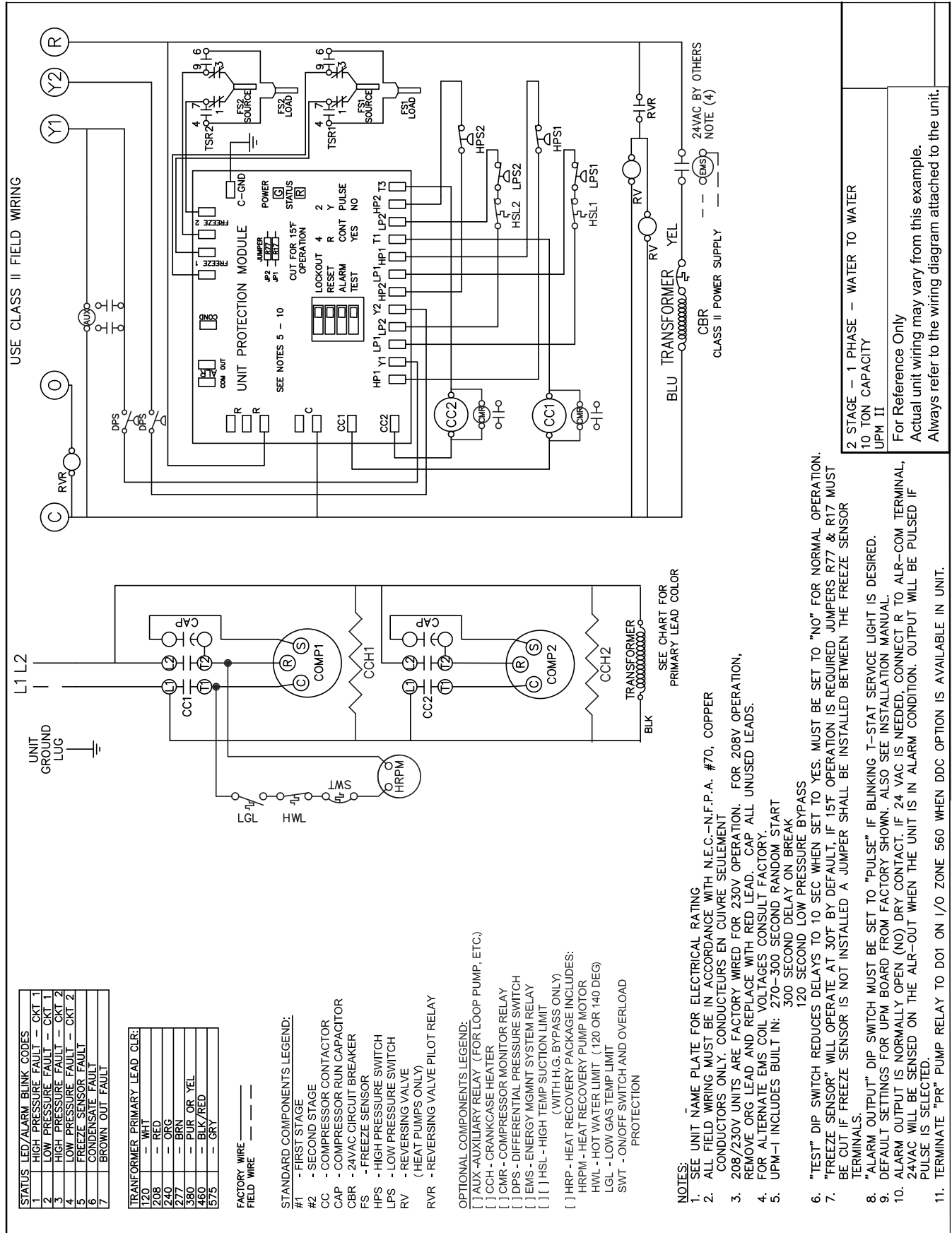

WIRING DIAGRAM

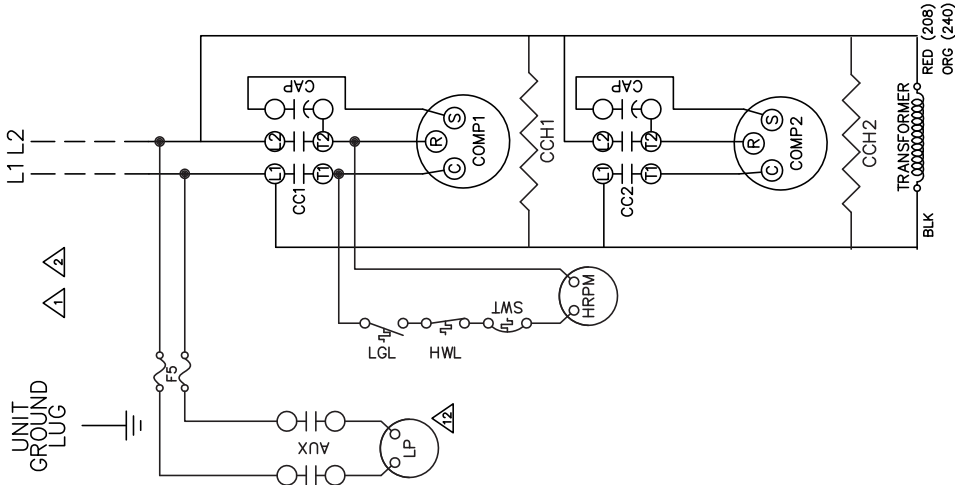
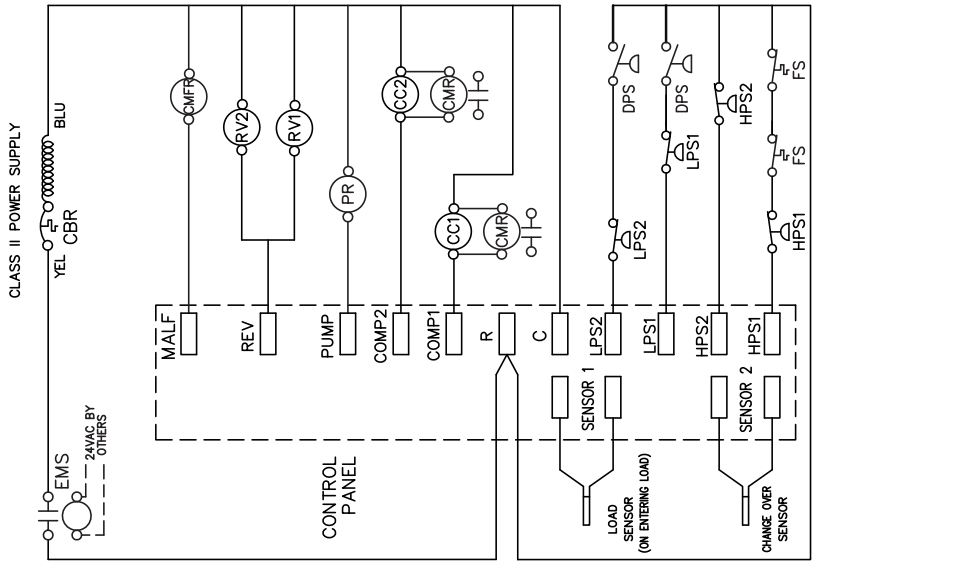

STANDARD COMPONENTS LEGEND:

- #1 - COMPRESSOR FIRST STAGE
- #2 - COMPRESSOR SECOND STAGE
- CAP - COMPRESSOR CAPACITOR
- CBR - 24 VAC CIRCUIT BREAKER
- CC - COMPRESSOR CONTACTOR
- HPS - HIGH PRESSURE SWITCH
- LPS - LOW PRESSURE SWITCH
- RV - REVERSING VALVE (HEAT PUMPS)

OPTIONAL COMPONENTS LEGEND:

- [] CCH - CRANKCASE HEATER
- [] CMFR - COMPRESSOR MALFUNCTION RELAY
- [] CMR - COMPRESSOR MONITOR RELAY
- [] DPS - DIFFERENTIAL PRESSURE SWITCH
- [] EMS - ENERGY MGMT SYSTEM RELAY
- [] FS - FREEZE STAT
- [] HGL - HOT GAS LIMIT (BYPASS ONLY)
- [] HRP - HEAT RECOVERY PACKAGE INCLUDES:
- [] HRP - HEAT RECOVERY PUMP MOTOR
- [] HWL - HOT WATER LIMIT (120 OR 140 DEG)
- [] LGL - LOW GAS TEMP LIMIT
- [] SWT - ON/OFF SWITCH AND OVERLOAD PROTECTION
- [] PR - PUMP RELAY

FACTORY WIRE ———

FIELD WIRE - - - - -

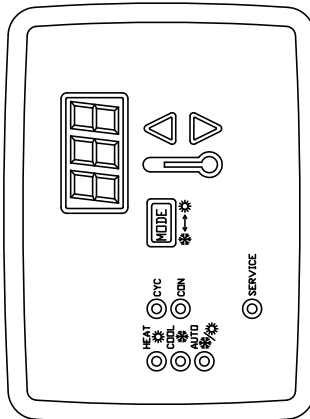

NOTES:

1. SEE UNIT NAME PLATE FOR ELECTRICAL RATING. ALL FIELD WIRING MUST BE IN ACCORDANCE WITH N.E.C.-N.F.P.A. #70, COPPER CONDUCTORS ONLY. CONDUCTEURS EN CUIVRE SEULEMENT
2. 208/230V UNITS ARE FACTORY WIRED FOR 230V OPERATION. FOR 208V OPERATION, REMOVE ORG LEAD AND REPLACE WITH RED LEAD. CAP ALL UNUSED LEADS.
5. DO NOT OPERATE WITH ACCESS PANELS REMOVED OR CABINET OPEN.
6. FOR ALTERNATE EMS COIL VOLTAGES CONSULT FACTORY.
7. UMC INCLUDES BUILT IN: 300 SECOND RANDOM START
120 SECOND DELAY ON BREAK
300 SECOND LOW PRESSURE BYPASS
8. SETTING THE TEST MODE JUMPER TO YES REDUCES ALL TIME DELAYS TO 5 SECONDS
9. "FREEZE" PINS ON UMC MUST BE JUMPED TOGETHER IF FREEZE SENSOR IS NOT INSTALLED
10. BLINK CODES FOR HARD LOCK OUT:

1	-	HIGH PRESSURE FAULT
2	-	LOW PRESSURE FAULT
3	-	HIGH PRESSURE 2 FAULT
4	-	LOW PRESSURE 2 FAULT

2 STAGE - 1 PHASE (ALL VOLTAGES)
WATER TO WATER - SOLID STATE UNIT CONTROLLER
UPM 1

For Reference Only
Actual unit wiring may vary from this example.
Always refer to the wiring diagram attached to the unit.

WIRING DIAGRAM

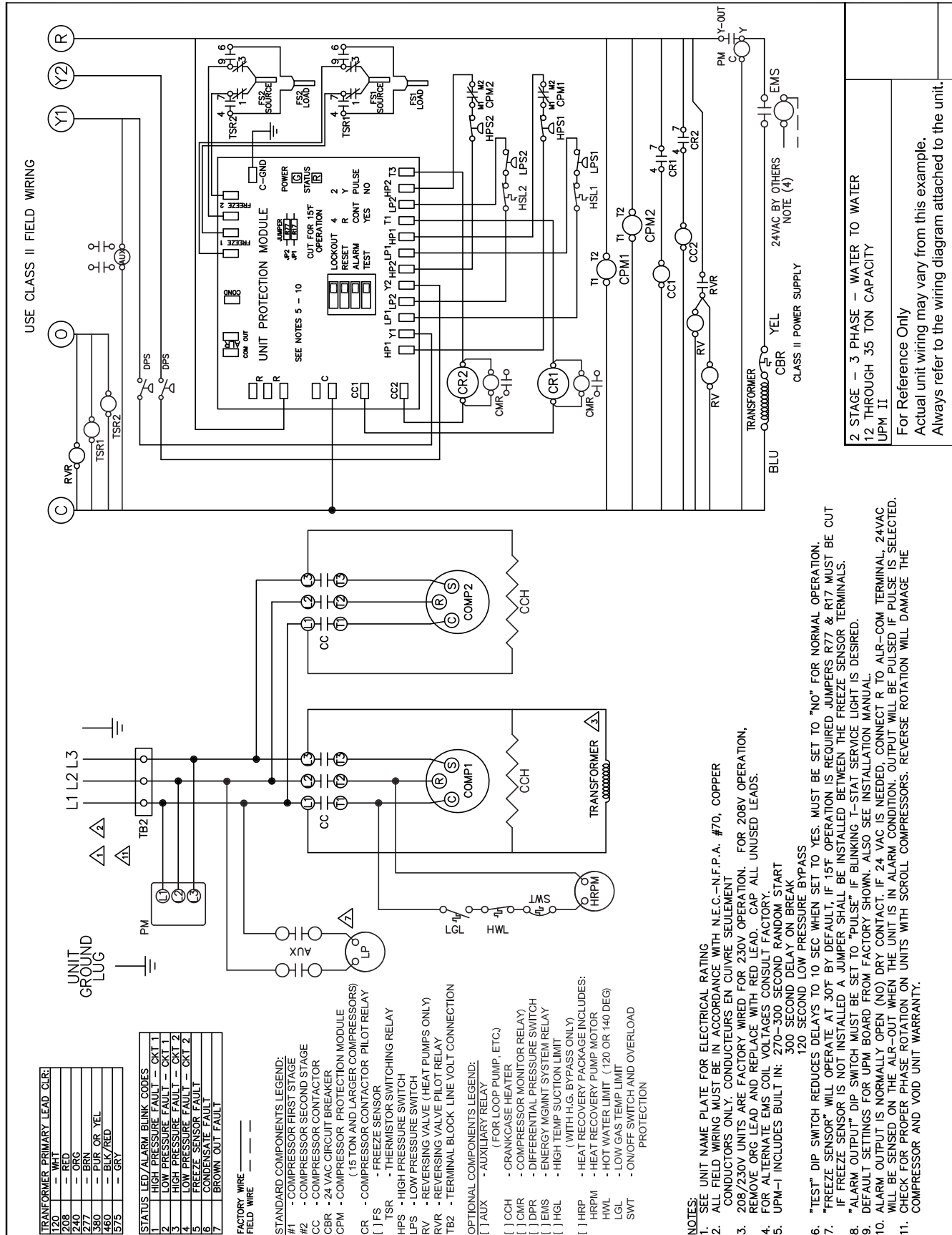

WIRING DIAGRAM

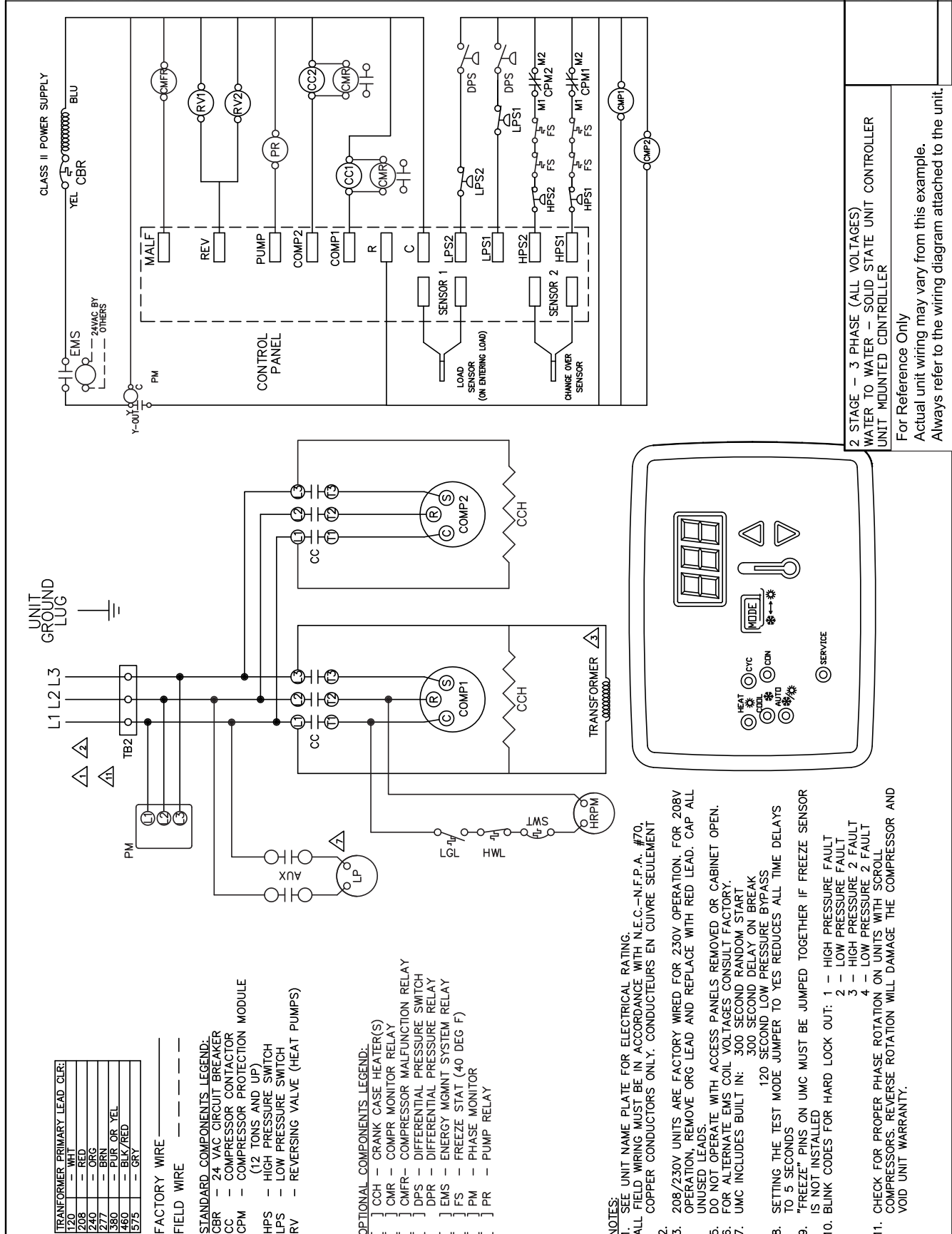

TRANSFORMER PRIMARY LEAD CLR.	UNIT
170	WT
208	RED
240	ORG
277	BRN
380	PUR OR YEL
460	BLK/RED
575	GRY

- FACTORY WIRE ———
 FIELD WIRE - - - - -
- STANDARD COMPONENTS LEGEND:
 CBR - 24 VAC CIRCUIT BREAKER
 CC - COMPRESSOR CONTACTOR
 CPM - COMPRESSOR PROTECTION MODULE
 (12 TONS AND UP)
 HPS - HIGH PRESSURE SWITCH
 LPS - LOW PRESSURE SWITCH
 RV - REVERSING VALVE (HEAT PUMPS)

- OPTIONAL COMPONENTS LEGEND:
 CCH - CRANK CASE HEATER(S)
 CMR - COMPRESSOR MONITOR RELAY
 CMFR - COMPRESSOR MALFUNCTION RELAY
 DPS - DIFFERENTIAL PRESSURE SWITCH
 DPR - DIFFERENTIAL PRESSURE RELAY
 EMS - ENERGY MGMT SYSTEM RELAY
 FS - FREEZE STAT (40 DEG F)
 PM - PUMP MONITOR
 PR - PUMP RELAY

- NOTES:
 1. SEE UNIT NAME PLATE FOR ELECTRICAL RATING. ALL FIELD WIRING MUST BE IN ACCORDANCE WITH N.E.C.—N.F.P.A. #70. COPPER CONDUCTORS ONLY. CONDUCTEURS EN CUIVRE SEULEMENT
 2. 208/230V UNITS ARE FACTORY WIRE FOR 230V OPERATION. FOR 208V OPERATION, REMOVE ORG LEAD AND REPLACE WITH RED LEAD. CAP ALL UNUSED LEADS.
 3. DO NOT OPERATE WITH ACCESS PANELS REMOVED OR CABINET OPEN.
 4. FOR ALTERNATE EMS COIL VOLTAGES CONSULT FACTORY.
 5. UMC INCLUDES BUILT IN: 300 SECOND RANDOM START
 300 SECOND DELAY ON BREAK
 120 SECOND LOW PRESSURE BYPASS
 6. SETTING THE TEST MODE JUMPER TO YES REDUCES ALL TIME DELAYS TO 5 SECONDS
 7. "FREEZE" PINS ON UMC MUST BE JUMPED TOGETHER IF FREEZE SENSOR IS NOT INSTALLED
 8. BLINK CODES FOR HARD LOCK OUT: 1 - HIGH PRESSURE FAULT
 2 - LOW PRESSURE FAULT
 3 - HIGH PRESSURE 2 FAULT
 4 - LOW PRESSURE 2 FAULT
 9. CHECK FOR PROPER PHASE ROTATION ON UNITS WITH SCROLL COMPRESSORS. REVERSE ROTATION WILL DAMAGE THE COMPRESSOR AND VOID UNIT WARRANTY.
 10. SETTING THE TEST MODE JUMPER TO YES REDUCES ALL TIME DELAYS TO 5 SECONDS
 11. "FREEZE" PINS ON UMC MUST BE JUMPED TOGETHER IF FREEZE SENSOR IS NOT INSTALLED
 12. BLINK CODES FOR HARD LOCK OUT: 1 - HIGH PRESSURE FAULT
 2 - LOW PRESSURE FAULT
 3 - HIGH PRESSURE 2 FAULT
 4 - LOW PRESSURE 2 FAULT

2 STAGE - 3 PHASE (ALL VOLTAGES)
 WATER TO WATER - SOLID STATE UNIT CONTROLLER
 UNIT MOUNTED CONTROLLER
 For Reference Only
 Actual unit wiring may vary from this example.
 Always refer to the wiring diagram attached to the unit.

TROUBLESHOOTING

Problem	Possible Cause	Checks and Corrections
COMPRESSOR DOES NOT OPERATE	Power supply off	Apply power, close disconnect.
	Blown fuse	Replace fuse or reset circuit breaker. Check for correct fuses.
	Broken or loose wires	Replace or tighten the wires. Check for loose or broken wires at compressor, capacitor, or contactor.
	Voltage supply low	If voltage is below minimum voltage specified on unit data plate, contact local power company.
	Controller	Set controller to "COOL" and lowest temperature setting, the unit should run in the cooling mode (reversing valve energized). Set unit to "HEAT" and the highest temperature setting, the unit should run in the heating mode. If the compressor does not run in all cases, the controller could be miswired or faulty. To ensure miswired or faulty thermostat verify 24 volts is available on the unit section low voltage terminal strip between "R" and "C", "Y" and "C", and "O" and "C". Replace the controller if defective.
	Safety controls	Reset the controller to "OFF". After a few minutes turn to "COOL" or "HEAT". If the compressor runs, unit was off on one of the safety controls. (See problem for possible causes)
	Compressor overload open	If the compressor is cool and the overload will not reset, replace compressor.
	Compressor motor grounded	Internal winding grounded to the compressor shell. Replace compressor. If compressor burnout, install suction filter dryer.
Compressor windings open	After compressor has cooled, check continuity of the compressor windings. If the windings are open, replace the compressor.	
UNIT OFF ON HIGH PRESSURE SWITCH	Discharge pressure too high	In "COOLING" mode: SOURCE COIL - Lack of or inadequate water flow. Entering water temperature too warm. Scaled or plugged condenser. In "HEATING" mode: LOAD COIL - Lack of or inadequate water flow. Entering water temperature too warm. Scaled or plugged load coil.
	Refrigerant charge	The unit is overcharged with refrigerant. Reclaim refrigerant, evacuate and recharge with factory recommended charge.
	High pressure switch	Check for defective or improperly calibrated high pressure switch.
UNIT OFF ON LOW PRESSURE SWITCH	Suction pressure too low	In "COOLING" mode: LOAD COIL - Lack of or inadequate fluid flow. Entering water temperature too cold. Scaled or plugged load coil. In "HEATING" mode: SOURCE COIL - Lack of or inadequate fluid flow. Entering water temperature too cold. Scaled or plugged source coil.
	Refrigerant charge	The unit is low on refrigerant. Check for refrigerant leak, repair, evacuate and recharge with factory recommended charge.
	Low pressure switch	Check for defective or improperly calibrated low-pressure switch.
UNIT SHORT CYCLES	Unit oversized	Recalculate heating and or cooling loads.
	Wiring and controls	Loose connections in the wiring or a defective compressor contactor.
	Fluid Volume	Inadequate load side fluid volume.
INSUFFICIENT COOLING OR HEATING	Unit undersized	Recalculate heating and or cooling loads. If excessive, possibly adding insulation and shading will rectify the problem. Unit may be short of refrigerant.
	Refrigerant charge	Unit may be short on refrigerant charge.
	Compressor	Check for defective compressor. If discharge is too low and suction pressure is too high, compressor is not pumping properly. Replace compressor.
	Reversing valve	Defective reversing valve creating bypass of refrigerant from discharge to suction side of compressor. Replace reversing valve.
	Operating pressures	Compare unit operating pressures to the pressure / temperature chart for the unit.
	TXV	Check TXV for possible restriction or defect. Replace if necessary
	Moisture, noncondensables	The refrigerant system may be contaminated with moisture or noncondensables. Reclaim refrigerant, evacuate and recharge with factory recommended charge. Note: a liquid line dryer may be required.

UNIT CHECK-OUT SHEET

Customer Data

Customer Name _____ Date _____
 Address _____
 Phone _____ Unit Number _____

Unit Nameplate Data

Unit Make _____
 Model Number _____ Serial Number _____
 Refrigerant Charge (oz) _____
 Compressor: RLA _____ LRA _____
 Blower Motor: FLA (or NPA) _____ HP _____
 Maximum Fuse Size (Amps) _____
 Minimum Circuit Ampacity (Amps) _____

Operating Conditions

	Cooling Mode	Heating Mode
Entering / Leaving Air Temp	_____ / _____	_____ / _____
Entering Air Measured at:	_____	_____
Leaving Air Measured at:	_____	_____
Entering / Leaving Fluid Temp	_____ / _____	_____ / _____
Fluid Flow (gpm)	_____	_____
Compressor Volts / Amps	_____ / _____	_____ / _____
Blower Motor Volts / Amps	_____ / _____	_____ / _____
Source Fluid Type	_____	_____
Fluid Flow (gpm)*	_____	_____
Fluid Side Pressure Drop*	_____	_____
Suction / Discharge Pressure (psig)*	_____ / _____	_____ / _____
Suction / Discharge Temp*	_____ / _____	_____ / _____
Suction Superheat*	_____	_____
Entering TXV / Cap Tube Temp*	_____	_____
Liquid Subcooling*	_____	_____

* Required for Troubleshooting ONLY

Auxiliary Heat

Unit Make _____
 Model Number _____ Serial Number _____
 Max Fuse Size (Amps) _____
 Volts / Amps _____ / _____
 Entering Air Temperature _____
 Leaving Air Temperature _____

Bosch Group 601 NW 65th Court Fort Lauderdale, FL 33309
 Phone: 866-642-3198 Fax: 800-776-5529
www.bosch-climate.us

601 N.W. 65th Court
Ft. Lauderdale, FL 33309
Phone: 866-642-3198
Fax: 954-776-5529
www.bosch-climate.us

970-294 (2014/06)

