

# INSTALLATION, OPERATING and SERVICE MANUAL

THE INSTALLATION OF THE UNIT SHALL BE IN ACCORDANCE WITH THE REGULATIONS OF THE AUTHORITIES HAVING JURISDICTION.

**OIL-FIRED LO-BOY – HEAVY DUTY FURNACES  
MODELS: NL2, NL3, NLF, NMR, NV2, NV3**

**HEAD OFFICE  
MARKETING / PRODUCTION  
Newmac Mfg. Inc.**

208 LANCASTER CRESCENT  
P.O. BOX 9, DEBERT  
NOVA SCOTIA, BOM 1G0  
PHONE: 902-662-3840  
FAX: 902-662-2581

**WAREHOUSE  
Newmac Mfg. Inc.**

430 SPRINGBANK AVE., SOUTH  
WOODSTOCK, ONTARIO  
N4V 1B2  
PHONE: 519-539-6147  
FAX: 519-539-0048



EMAIL: [newmac@newmacfurnaces.com](mailto:newmac@newmacfurnaces.com)  
WEB SITE: [newmacfurnaces.com](http://newmacfurnaces.com)  
**NOTICE TO HOMEOWNER:  
READ AND SAVE THESE INSTRUCTIONS**



2210049 Revised August 2009

**FIG. 1 - DELHI 'G' SERIES BLOWER PERFORMANCE DATA**

HP includes drive losses for belt drive blowers

MODEL	CAPACITY CFM	OUTLET VEL FPM	1/8" SP		1/4" SP		3/8" SP		1/2" SP		5/8" SP		3/4" SP		1" SP	
			RPM	HP	RPM	HP	RPM	HP	RPM	HP	RPM	HP	RPM	HP	RPM	HP
<b>Max HP 3/4</b>  <b>G9</b>	600	713	355	.03	495	.05	625	.08	745	.11	845	.15	925	.19	1060	.24
	800	951	395	.05	495	.07	605	.10	700	.13	800	.17	905	.22	1065	.30
	1000	1189	455	.09	525	.11	615	.14	700	.17	775	.20	855	.24	1010	.33
	1200	1427	515	.14	575	.16	640	.19	710	.22	780	.25	855	.29	995	.38
	1400	1665	580	.21	640	.24	685	.26	745	.30	805	.34	865	.37	990	.46
<b>Max HP 3/4</b>  <b>G9 DD</b>	600	713	460	.03	600	.06	725	.08	815	.10	935	.13	1005	.16	1155	.23
	800	951	475	.05	600	.08	730	.11	820	.13	925	.18	1005	.19	1175	.28
	1000	1189	510	.08	620	.11	740	.15	835	.17	940	.22	1005	.25	1165	.34
	1200	1427	560	.12	655	.16	760	.19	850	.23	945	.28	1015	.31	1170	.41
	1400	1665	630	.19	705	.22	800	.27	870	.30	960	.35	1025	.39	1180	.50
<b>Max HP 3/4</b>  <b>G10-8 DD</b>	600	724	400	.03	500	.04	625	.07	710	.09	810	.12	885	.14	1010	.20
	800	965	410	.06	515	.07	630	.10	700	.12	800	.11	870	.18	1010	.25
	1000	1206	465	.08	550	.11	640	.13	710	.16	800	.20	865	.23	1005	.30
	1200	1448	500	.12	595	.16	670	.19	735	.22	805	.26	875	.30	1000	.37
	1400	1689	585	.20	640	.23	700	.26	770	.30	840	.34	900	.38	1010	.47
<b>Max HP 3/4</b>  <b>G10</b>	800	378	320	.04	445	.06	545	.08	635	.11	710	.14	790	.18	915	.25
	1000	472	345	.06	450	.08	540	.11	630	.14	705	.17	780	.21	905	.29
	1200	566	395	.08	460	.11	545	.15	630	.19	705	.22	775	.25	905	.34
	1400	661	440	.13	485	.15	555	.19	630	.23	705	.28	775	.31	900	.40
	1600	755	485	.20	535	.22	580	.25	645	.29	710	.34	770	.38	900	.47
	1800	850	525	.27	575	.30	620	.33	665	.37	720	.41	780	.46	900	.57
<b>Max HP 1 1/2</b>  <b>G12</b>	1200	823	300	.06	400	.11	500	.16	595	.23	705	.34	765	.41	870	.57
	1400	960	310	.08	400	.13	495	.18	570	.24	660	.32	750	.43	895	.65
	1600	1097	340	.12	410	.16	495	.21	565	.27	640	.35	710	.43	875	.67
	1800	1235	360	.15	425	.20	500	.26	565	.31	635	.38	700	.46	820	.64
	2200	1509	420	.26	470	.31	515	.36	580	.43	640	.50	700	.58	805	.75
	2600	1783	485	.40	525	.46	565	.51	605	.58	655	.65	705	.74	805	.92
	3000	2058	540	.60	585	.66	620	.73	650	.78	685	.86	725	.94	815	1.14

Twin Blowers have double the CFM capacity for the same RPM and SP and require double the horsepower

DD Designates Direct Drive

Note – Specifications may change without notice

## FIG. 2A - GENERAL INSTRUCTIONS

It is the responsibility of the consignee to the unit to examine the packages for damage and, if found to note the same on the Carrier's Bill of Lading. The furnace is shipped in two (2) packages:

1. Furnace complete with combustion chamber, circulating blower, combination fan-limit control, air filters and draft regulator.
2. Oil burner complete with primary relay, photo-cell, and nozzle.

MODEL	NL2-77	NL2-89	NL2-101	NL2-118	NLF-77	NLF-89	NLF-101	NLF-118	NMR-77	NMR-89	NMR-101	NMR-118
B.T.U.H. INPUT (USGPH)	90,610 (.65)	104,550 (.75)	118,490 (.85)	139,400 (1.0)	90,610 (.65)	104,550 (.75)	118,490 (.85)	139,400 (1.0)	90,610 (.65)	104,550 (.75)	118,490 (.85)	139,400 (1.0)
B.T.U.H. OUTPUT	77,000	89,000	101,000	118,000	77,000	89,000	101,000	118,000	77,000	89,000	101,000	118,000
% AFUE RATING (ETL)	84.8	84.6	84.6	83.8	82.4	82.1	82.6	81.6	83.9	83.7	83	80.1
BURNER	AERO HF-US-2X				BECKETT AFG-AF81WPHS				BECKETT AF-AF81WPHS			
INSERTION	6-7/8"	6-7/8"	6-7/8"	6-7/8"	7-7/8"	7-7/8"	7-7/8"	7-7/8"	7-7/8"	7-7/8"	7-7/8"	7-7/8"
NOZZLE DELAVAN 70 A / 80 W	0.65	0.75	0.85	1	0.65	0.75	0.85	1	0.65	0.75	0.85	1
NOZZLE MONARCH 70 NS / 80 R	0.65	0.75	0.85	1	0.65	0.75	0.85	1	0.65	0.75	0.85	1
PUMP PRESSURE (P.S.I.)	100	100	100	100	100	100	100	100	100	100	100	100
BURNER: RIELLO R40-F3-10	6.75" T.F. INSERTION PLUS CERAMIC SLEEVE				7.75" T.F. INSERTION PLUS CERAMIC SLEEVE				7.75" T.F. INSERTION PLUS CERAMIC SLEEVE			
NOZZLE DELAVAN 60 W	0.60	0.65	0.75	0.85	0.60	0.65	0.75	0.85	0.60	0.65	0.75	0.85
PUMP PRESSURE (P.S.I.)	120	135	130	140	120	135	130	140	120	135	130	140
REG. STOP GATE SETTING	0.5	1	2.4	3	0.5	1	2	3	0.5	1	2	3
APPROX. AIR GATE SETTING	2.4	3	4	5	2.4	3	3.6	4.5	2.4	3	4	5
BURNER : RIELLO R35.3.07	6.75" T.F. INSERTION PLUS CERAMIC SLEEVE				7.75" T.F. INSERTION PLUS CERAMIC SLEEVE				7.75" T.F. INSERTION PLUS CERAMIC SLEEVE			
NOZZLE DELAVAN 60 W	0.60	0.65	0.75	0.85	0.60	0.65	0.75	0.85	0.60	0.65	0.75	0.85
PUMP PRESSURE (P.S.I.)	120	135	130	140	120	135	130	140	120	135	130	140
REG. STOP GATE SETTING	1	1	2.5	3	1	1	3	3.5	1	1	2.5	3
APPROX. AIR GATE SETTING	1	2.5	3	4	2	2.5	3	4	2	2.5	3.5	4
MIN. OVER-FIRE PRESSURE	-.005"	-.005"	-.005"	-.005"	-.005"	-.005"	-.005"	-.005"	-.005"	-.005"	-.005"	-.005"
CFM	1,100	1,200	1,350	1,500	1,025	1,200	1,300	1,400	1,025	1,150	1,250	1,350
FLUE PRESSURE	-.02" W.C.	-.02" W.C.	-.02" W.C.	-.02" W.C.	-.02" W.C.	-.02" W.C.	-.02" W.C.	-.02" W.C.	-.02" W.C.	-.02" W.C.	-.02" W.C.	-.02" W.C.
<b>BELT DRIVE MODELS</b>												
BLOWER	DELHI G-10 OR LAU-1010 OR TORIN BC1020				DELHI G-10				DELHI G-10			
BLOWER MOTOR	1/3 HP	1/3 HP	1/3 HP	1/3 HP	1/3 HP	1/3 HP	1/3 HP	1/3 HP	1/3 HP	1/3 HP	1/3 HP	1/3 HP
@ .20" W.C. STATIC PRESSURE												
MOTOR PULLEY	3-1/4"	3-1/4"	3-1/4"	3-1/4"	3-1/4"	3-1/4"	3-1/4"	3-1/4"	3-1/4"	3-1/4"	3-1/4"	3-1/4"
# OF PULLEY TURNS OPEN	3-1/2 T.O.	2 1/2 T.O.	1 1/2 T.O.	1/2 T.O.	5-1/2 T.O.	4-1/2 T.O.	3-1/2 T.O.	2-1/2 T.O.	4 T.O.	3 T.O.	2 T.O.	0 T.O.
BLOWER PULLEY	7"	7"	7"	7"	7"	7"	7"	7"	7"	7"	7"	7"
BELT SIZE	1/2" x 41"	1/2" X 41"	1/2" X 41"	1/2" X 41"	1/2" X 43"	1/2" X 43"	1/2" X 43"	1/2" X 43"	1/2" X 41"	1/2" X 41"	1/2" X 41"	1/2" X 41"
@ .50" W.C. STATIC PRESSURE												
MOTOR PULLEY	3-1/2"	3-1/2"	3-1/2"	3-1/2"	3-1/4"	3-1/4"	3-1/4"	3-1/4"	3-1/4"	3-1/4"	3-1/4"	3-1/4"
# OF PULLEY TURNS OPEN	3-1/2 T.O.	3 T.O.	2-1/2 T.O.	1-1/2 T.O.	3 T.O.	2-1/2 T.O.	2 T.O.	1-1/2 T.O.	2-1/2 T.O.	1-1/2 T.O.	1 T.O.	0 T.O.
BLOWER PULLEY	6"	6"	6"	6"	6"	6"	6"	6"	6"	6"	6"	6"
BELT SIZE	1/2" X 38"	1/2" X 38"	1/2" X 38"	1/2" X 38"	1/2" X 40"	1/2" X 40"	1/2" X 40"	1/2" X 40"	1/2" X 38"	1/2" X 38"	1/2" X 38"	1/2" X 38"
<b>DIRECT DRIVE MODELS</b>												
BLOWER	DELHI G10-8DD				DELHI G10-8DD				DELHI G10-8DD			
4 SPEED BLOWER MOTOR	1/2 HP	1/2 HP	1/2 HP	1/2 HP	1/2 HP	1/2 HP	1/2 HP	1/2 HP	1/2 HP	1/2 HP	1/2 HP	1/2 HP
@ .20" W.C. STATIC PRESSURE												
SPEED TAP	LOW	MED-LOW	MED-LOW	MED-HIGH	LOW	MED-LOW	MED-LOW	MED-HIGH	MED-LOW	MED-LOW	MED-HIGH	MED-HIGH
@ .50" W.C. STATIC PRESSURE												
SPEED TAP	LOW	MED-LOW	MED-HIGH	HIGH	LOW	MED-LOW	MED-LOW	HIGH	MED-LOW	MED-LOW	HIGH	HIGH
FILTERS (QTY)	16" X 24" (2)	16" X 24" (2)	16" X 24" (2)	16" X 24" (2)	16" X 24" (2)	16" X 24" (2)	16" X 24" (2)	16" X 24" (2)	16" X 24" (1)	16" X 24" (1)	16" X 24" (1)	16" X 24" (1)
									12" X 24" (1)	12" X 24" (1)	12" X 24" (1)	12" X 24" (1)

Use burner air settings as a guide only. Set burner air to give a trace of smoke. Re-adjust burner air to reduce CO<sub>2</sub> reading by 1 to 1.5 percent. Take measurements with the burner cover & air ducts installed (if any). See burner manufacturer's instructions for more information. If settings differ, use those on the appliance label. Blower Speeds are based on a maximum temperature rise of 85°F. Adjust speed to suit specific installation. Select high speed for maximum cooling capacity. Air temperature rise can be lowered by increasing blower speed, lowering firing rate, or increasing supply or return outlets.

## FIG. 2B - GENERAL INSTRUCTIONS

It is the responsibility of the consignee to the unit to examine the packages for damage and, if found to note the same on the Carrier's Bill of Lading. The furnace is shipped in two (2) packages :

1. Furnace complete with combustion chamber, circulating blower, combination fan-limit control, air filters and draft regulator.
2. Oil burner complete with primary relay, photo-cell, and nozzle.

MODEL	NL3-121	NL3-149	NL3-160	NL3-177
B.T.U.H. INPUT (USGPH)	139,400 (1.00)	174,250 (1.25)	188,190 (1.35)	209,100 (1.50)
B.T.U.H. OUTPUT	121,000	149,000	160,000	177,000
% AFUE RATING (ETL)	83.0	81.0	82.1	80.4
BURNER	AERO HF-US-3 OR BECKETT AFG-AF81YYHS INSERTION 7-7/8"			
NOZZLE DELAVAN 70 B/A 80 W	1.00	1.25	1.35	1.50
NOZZLE MONARCH 70 NS/80 R	1.00	1.25	1.35	1.50
PUMP PRESSURE (psi)	100	100	100	100
BURNER	RIELLO R40-F5-10 INSERTION 7.75" T.F. PLUS CERAMIC SLEEVE			
NOZZLE DELAVAN 60 B/A/W	0.85	1.00	1.10	1.25
PUMP PRESSURE (psi)	145	150	150	145
REG. STOP GATE SETTING	2	2	2	2
APPROX. AIR GATE SETTING	2.1	2.65	2.82	3.5
MINIMUM OVER-FIRE PRESSURE	-.005" W.C.	-.005" W.C.	-.005" W.C.	-.005" W.C.
MINIMUM FLUE PRESSURE	-.02" W.C.	-.02" W.C.	-.02" W.C.	-.02" W.C.
CFM	1,500	1,800	1,950	2,100
BLOWER	DELHI G-12 OR *LAU-A12-12 OR *TORIN-BC1220 (SEE NOTE)			
BLOWER MOTOR	1/2 HP	1/2 HP	1/2 HP	1/2 HP
@ .20" W.C. STATIC PRESSURE	1,500 CFM	1,800 CFM	1,950 CFM	2,100 CFM
PULLEY COMBINATION	3-1/4" X 8"	3-1/4" X 8"	3-1/4" X 8"	3-1/4" X 8"
# PULLEY TURNS OPEN	4-1/2 T.O.	3 T.O.	2 T.O.	1 T.O.
BELT SIZE	1/2" X 47"	1/2" X 47"	1/2" X 47"	1/2" X 47"
BLOWER	DELHI G-12	DELHI G-12	DELHI G-12	DELHI G-12
@ .50" W.C. STATIC PRESSURE				
BLOWER MOTOR	3/4 HP	3/4 HP	3/4 HP	3/4 HP
PULLEY COMBINATION	3-1/2" X 7"	3-1/2" X 7"	3-1/2" X 7"	3-1/2" X 7"
# PULLEY TURNS OPEN	3-1/2 T.O.	2 T.O.	2 T.O.	1 T.O.
BELT SIZE	44"	44"	44"	44"
FILTERS (QTY)	16" X 25" (1)	16" X 25" (1)	16" X 25" (1)	16" X 25" (1)
	20" X 25" (1)	20" X 25" (1)	20" X 25" (1)	20" X 25" (1)
*For 0.50" W.C. static pressure use Delhi Blower and 3/4 HP motor.				
Note : With 1.50 nozzles Lau and Torin blowers require 3/4 HP motors.				
Delhi blower : 3/4 HP motor is "optional equipment."				

Use burner air settings as a guide only. Set burner air to give a trace of smoke. Re-adjust burner air to reduce CO<sub>2</sub> by 1 to 1.5 percent. Take measurements with the burner cover & air ducts installed (if any). See burner manufacturer's instructions for more information. If settings differ, use those on the appliance label. Blower Speeds are based on a maximum temperature rise of 85°F. Adjust speed to suit specific installation. Select high speed for maximum cooling capacity. Air temperature rise can be lowered by increasing blower speed, lowering firing rate, or increasing supply or return outlets.

**FIG. 2C - GENERAL INSTRUCTIONS – NV2**

MODEL	BECKETT BURNER	SVS	B.T.U.H. OUTPUT	B.T.U.H. INPUT (USGPH)	AFUE %	NOZZLE	PUMP p.s.i.	INSERTION inches	BURNER AIR SETTING		CHIMNEY FLUE PRESSURE (in. w.c.)	GROSS STACK F <sup>0</sup>	FILTER SIZE (QTY)	DIRECT DRIVE SPEED TAP		BELT		EXTERNAL STATIC PRESSURE (in. w.c.)
									SHUTTER	AIR BAND				12" BLOWER	10" BLOWER	PULLEY COMBINATION	TURNS OPEN	
NV2-121V	AF81WPHS	Yes	120,000	139,400 (1.00)	83.8	Delavan Monarch 1.00 X 70° A 1.00 X 70° NS	100	6-7/8"	10	0	-0.02	510	16" X 24" (2)	MED	MED-HI	3-1/4" X 7"	1/2	0.2
														MED-HI	HI	3-1/2" X 6"	2	0.50
NV2-104V	AF81WPHS	Yes	104,000	118,490 (0.85)	84.6	Delavan Monarch 0.85 X 70° A 0.85 X 70° NS	100	6-7/8"	9	0	-0.02	460	16" X 24" (2)	MED-LO	MED-LO	3-1/4" X 7"	1-1/2	0.2
														MED	MED-HI	3-1/2" X 6"	3	0.50
NV2-92V	AF81WPHS	Yes	92,000	104,550 (0.75)	84.6	Delavan Monarch 0.75 X 70° A 0.75 X 70° NS	100	6-7/8"	6	0	-0.02	430	16" X 24" (2)	MED-LO	MED-LO	3-1/4" X 7"	2-1/2	0.2
														MED-LO	MED-LO	3-1/2" X 6"	3-1/2	0.50
NV2-79V	AF81WPHS	Yes	79,000	90,610 (0.65)	84.8	Delavan Monarch 0.65 X 70° A 0.65 X 70° NS	100	6-7/8"	5	0	-0.02	400	16" X 24" (2)	LO	LO	3-1/4" X 7"	3-1/2	0.2
														LO	LO	3-1/2" X 6"	4	0.50

MODEL	RIELLO BURNER	SVS	B.T.U.H. OUTPUT	B.T.U.H. INPUT (USGPH)	AFUE %	NOZZLE	PUMP p.s.i.	INSERTION inches	BURNER AIR SETTING		CHIMNEY FLUE PRESSURE (in. w.c.)	GROSS STACK F <sup>0</sup>	FILTER SIZE (QTY)	DIRECT DRIVE SPEED TAP		BELT		EXTERNAL STATIC PRESSURE (in. w.c.)
									TURBULATOR	AIR DAMPER				12" BLOWER	10" BLOWER	PULLEY COMBINATION	TURNS OPEN	
NV2-125	40F3	---	126,000	144,976 (1.04)	83.8	Delavan 0.85 X 60° W	150	6-3/4"	3	5.5	-0.02	520	16" X 24" (2)	MED-HI	MED-HI	3-1/4" X 7"	0	0.2
														MED-HI	HI	3-1/2" X 6"	1	0.50
NV2-112	40F3	---	112,000	128,248 (0.92)	84.6	Delavan 0.75 X 60° W	150	6-3/4"	3	4.3	-0.02	480	16" X 24" (2)	MED	MED-LO	3-1/4" X 7"	1	0.2
														MED	MED-HI	3-1/2" X 6"	2	0.50
NV2-98	40F3	---	98,000	111,520 (0.80)	84.6	Delavan 0.65 X 60° W	150	6-3/4"	3	3.6	-0.02	450	16" X 24" (2)	MED-LO	MED-LO	3-1/4" X 7"	2	0.2
														MED-LO	MED-LO	3-1/2" X 6"	3	0.50
NV2-93	40F3	---	90,000	101,762 (0.73)	84.8	Delavan 0.60 X 60° W	150	6-3/4"	3	3.4	-0.02	425	16" X 24" (2)	MED-LO	MED-LO	3-1/4" X 7"	3	0.2
														MED-LO	MED-LO	3-1/2" X 6"	3	0.50

MODEL	RIELLO BURNER	SVS	B.T.U.H. OUTPUT	B.T.U.H. INPUT (USGPH)	AFUE %	NOZZLE	PUMP p.s.i.	INSERTION inches	BURNER AIR SETTING		CHIMNEY FLUE PRESSURE (in. w.c.)	GROSS STACK F <sup>0</sup>	FILTER SIZE (QTY)	DIRECT DRIVE SPEED TAP		BELT		EXTERNAL STATIC PRESSURE (in. w.c.)
									TURBULATOR	AIR DAMPER				12" BLOWER	10" BLOWER	PULLEY COMBINATION	TURNS OPEN	
NV2-111V	BF3	Yes	110,000	125,460 (0.90)	84.6	Delavan 0.75 X 60° W	145	6-3/4"	3	7	-0.02	480	16" X 24" (2)	MED	MED-LO	3-1/4" X 7"	1	0.2
														MED	MED-HI	3-1/2" X 6"	2	0.50
NV2-97V	BF3	Yes	97,000	108,732 (0.78)	84.6	Delavan 0.65 X 60° W	145	6-3/4"	3	5	-0.02	450	16" X 24" (2)	MED-LO	MED-LO	3-1/4" X 7"	2	0.2
														MED-LO	MED-LO	3-1/2" X 6"	3	0.50
NV2-88V	BF3	Yes	89,000	100,368 (0.72)	84.8	Delavan 0.60 X 60° W	145	6-3/4"	3	4.4	-0.02	425	16" X 24" (2)	MED-LO	MED-LO	3-1/4" X 7"	3	0.2
														MED-LO	MED-LO	3-1/2" X 6"	3	0.50

Models with the suffix V are certified and listed for use with the Newmac SVS sealed direct vent system

Use burner air settings as a guide only. Set burner air to give a trace of smoke. Re-adjust burner air to reduce CO<sub>2</sub> by 1 to 1.5 percent. Take measurements with the burner cover & air ducts installed (if any).

The maximum allowable temperature rise is 85° F. Select speed to suit specific installation requirements. Air temperature can be lowered by the blower speed; lowering the firing rate; or increasing supply & return outlets.

The minimum recommended temperature rise is 65° F.

**FIG. 2C - GENERAL INSTRUCTIONS – NV2 (continued)**

MODEL	AERO BURNER	SVS	B.T.U.H. OUTPUT	B.T.U.H. INPUT (USGPH)	AFUE %	NOZZLE		PUMP p.s.i.	INSERTION inches	BURNER AIR SETTING		CHIMNEY FLUE PRESSURE (in. w.c.)	GROSS STACK F <sup>0</sup>	FILTER SIZE (QTY)	DIRECT DRIVE SPEED TAP		BELT DRIVE		EXTERNAL STATIC PRESSURE (in. w.c.)
															12" BLOWER	10" BLOWER	PULLEY COMBINATION	TURNS OPEN	
NV2-120	HF-US-2X	---	121,000	139,400 (1.00)	83.8	Delavan Monarch	1.00 X 70° A	100	6-7/8"			-0.02	510	16" X 24" (2)	MED	MED-HI	3-1/4" X 7"	1/2	0.20
							1.00 X 70° NS								MED-HI	HI	3-1/2" X 6"	2	0.50
NV2-105	HF-US-2X	---	104,000	118,490 (0.85)	84.6	Delavan Monarch	0.85 X 70° A	100	6-7/8"			-0.02	460	16" X 24" (2)	MED-LO	MED-LO	3-1/4" X 7"	1-1/2	0.20
							0.85 X 70° NS								MED	MED-HI	3-1/2" X 6"	3	0.50
NV2-91	HF-US-2X	---	92,000	104,550 (0.75)	84.6	Delavan Monarch	0.75 X 70° A	100	6-7/8"			-0.02	430	16" X 24" (2)	MED-LO	MED-LO	3-1/4" X 7"	2-1/2	0.20
							0.75 X 70° NS								MED-LO	MED-LO	3-1/2" X 6"	3-1/2	0.50
NV2-76	HF-US-2X	---	79,000	90,610 (0.65)	84.8	Delavan Monarch	0.65 X 70° A	100	6-7/8"			-0.02	400	16" X 24" (2)	LO	LO	3-1/4" X 7"	3-1/2	0.20
							0.65 X 70° NS								LO	LO	3-1/2" X 6"	4	0.50

MODEL	AERO BURNER	SVS	B.T.U.H. OUTPUT	B.T.U.H. INPUT (USGPH)	AFUE %	NOZZLE		PUMP p.s.i.	INSERTION inches	BURNER AIR SETTING		CHIMNEY FLUE PRESSURE (in. w.c.)	GROSS STACK F <sup>0</sup>	FILTER SIZE (QTY)	DIRECT DRIVE SPEED TAP		BELT DRIVE		EXTERNAL STATIC PRESSURE (in. w.c.)
															12" BLOWER	10" BLOWER	PULLEY COMBINATION	TURNS OPEN	
NV2-103	F-AFC-2	---	102,000	118,490 (0.85)	84.6	Delavan Monarch	0.85 X 70° A	100	6-7/8"			-0.02	460	16" X 24" (2)	MED-LO	MED-LO	3-1/4" X 7"	1-1/2	0.20
							0.85 X 70° NS								MED	MED-HI	3-1/2" X 6"	3	0.50
NV2-89	F-AFC-2	---	91,000	104,550 (0.75)	84.6	Delavan Monarch	0.75 X 70° A	100	6-7/8"			-0.02	430	16" X 24" (2)	MED-LO	MED-LO	3-1/4" X 7"	2-1/2	0.20
							0.75 X 70° NS								MED-LO	MED-LO	3-1/2" X 6"	3-1/2	0.50
NV2-77	F-AFC-2	---	79,000	90,610 (0.65)	84.8	Delavan Monarch	0.65 X 70° A	100	6-7/8"			-0.02	400	16" X 24" (2)	LO	LO	3-1/4" X 7"	3-1/2	0.20
							0.65 X 70° NS								LO	LO	3-1/2" X 6"	4	0.50

MODEL	CARLIN BURNER	SVS	B.T.U.H. OUTPUT	B.T.U.H. INPUT (USGPH)	AFUE %	NOZZLE		PUMP p.s.i.	INSERTION inches	BURNER AIR SETTING		CHIMNEY FLUE PRESSURE (in. w.c.)	GROSS STACK F <sup>0</sup>	FILTER SIZE (QTY)	DIRECT DRIVE SPEED TAP		BELT DRIVE		EXTERNAL STATIC PRESSURE (in. w.c.)
										POSITIONING BAR	AIR BAND				12" BLOWER	10" BLOWER	PULLEY COMBINATION	TURNS OPEN	
NV2-119V	EZ-1	Yes	119,000	139,400 (1.00)	83.8	Delavan	1.00 X 70° A	100	6-7/8"	0.85-1.00 GPH	1.00	-0.02	510	16" X 24" (2)	MED	MED-HI	3-1/4" X 7"	1/2	0.20
											MED-HI				HI	3-1/2" X 6"	2	0.50	
NV2-102V	EZ-1	Yes	102,000	118,490	84.6	Delavan	0.85 X 70° A	100	6-7/8"	0.85/1.00 GPH	0.85	-0.02	460	16" X 24" (2)	MED-LO	MED-LO	3-1/4" X 7"	1-1/2	0.20
											MED				MED-HI	3-1/2" X 6"	3	0.50	
NV2-90V	EZ-1	Yes	91,000	104,550 (0.75)	84.6	Delavan	0.75 X 70° A	100	6-7/8"	0.75 GPH	0.75	-0.02	430	16" X 24" (2)	MED-LO	MED-LO	3-1/4" X 7"	2-1/2	0.20
											MED-LO				MED-LO	3-1/2" X 6"	3-1/2	0.50	
NV2-78V	EZ-1	Yes	79,000	90,610 (0.65)	84.8	Delavan	0.65 X 70° A	100	6-7/8"	0.60-0.65 GPH	0.65	-0.02	400	16" X 24" (2)	LO	LO	3-1/4" X 7"	3-1/2	0.20
											LO				LO	3-1/2" X 6"	4	0.50	

Models with the suffix V are certified and listed for use with the Newmac SVS sealed direct vent system

Use burner air settings as a guide only. Set burner air to give a trace of smoke. Re-adjust burner air to reduce CO<sub>2</sub> by 1 to 1.5 percent. Take measurements with the burner cover & air ducts installed (if any).

The maximum allowable temperature rise is 85° F. Select speed to suit specific installation requirements. Air temperature can be lowered by the blower speed; lowering the firing rate; or increasing supply & return outlets.

The minimum recommended temperature rise is 65° F.

**FIG. 2D - GENERAL INSTRUCTIONS – NV3**

Model	Beckett Burner	SVS	B.T.U.H. Output	B.T.U.H. Input (USGPH)	AFUE %	Nozzle	Pump p.s.i.	Insertion inches	Burner Air Setting		Chimney Flue Pressure (in w.c.)	Gross Stack °F	Filter Size (qty)	Direct Drive	Belt Drive		External Static Pressure (in w.c.)
									12" Blower	Pulley Combination				Turns Open			
NV3-177V*	AF81YYHS	Yes	177,000	209,100 (1.50)	80.4	Delavan 1.50 X 70° A/B Monarch 1.50 X 70° NS	100	7-7/8"			-0.02	540	16" X 25" (1) 20" X 25" (1)	HI	3-1/4" X 8"	1/2	0.20
														HI	3-1/2" X 7"	1-1/2	0.50
NV3-159V	AF81YYHS	Yes	164,000	188,190 (1.35)	82.1	Delavan 1.35 X 70° A/B Monarch 1.35 X 70° NS	100	7-7/8"			-0.02	500		HI	3-1/4" X 8"	1-1/2	0.20
														HI	3-1/2" X 7"	2-1/2	0.50
NV3-148V	AF81YYHS	Yes	151,000	174,250 (1.25)	81.0	Delavan 1.25 X 70° A/B Monarch 1.25 X 70° NS	100	7-7/8"			-0.02	465		MED-HI	3-1/4" X 8"	2	0.20
														MED-HI	3-1/2" X 7"	2-1/2	0.50
NV3-118V	AF81YYHS	Yes	120,000	140,000 (1.00)	83.0	Delavan 1.00 X 70° A/B Monarch 1.00 X 70° NS	100	7-7/8"			-0.02	400		MED	3-1/4" X 8"	3-1/2	0.20
														MED	3-1/2" X 7"	3-1/2	0.50

Model	Riello Burner	SVS	B.T.U.H. Output	B.T.U.H. Input (USGPH)	AFUE %	Nozzle	Pump p.s.i.	Insertion inches	Burner Air Setting		Chimney Flue Pressure (in w.c.)	Gross Stack °F	Filter Size (qty)	Direct Drive	Belt Drive		External Static Pressure (in w.c.)
									12" Blower	Pulley Combination				Turns Open			
NV3-181	40F5	-	180,000	214,676 (1.54)	80.4	Delavan 1.25 X 60° A/B/W	150	7-3/4"	2	4.3	-0.02	550	16" X 25" (1) 20" X 25" (1)	HI	3-1/4" X 8"	1/2	0.20
														HI	3-1/2" X 7"	1-1/2	0.50
NV3-160	40F5	-	164,000	188,190 (1.35)	82.1	Delavan 1.10 X 60° A/B/W	150	7-3/4"	2	3.5	-0.02	500		HI	3-1/4" X 8"	1-1/2	0.20
														HI	3-1/2" X 7"	2-1/2	0.50
NV3-144	40F5	-	145,000	170,068 (1.22)	81.0	Delavan 1.00 X 60° A/B/W	150	7-3/4"	2	2.9	-0.02	455		MED-HI	3-1/4" X 8"	2	0.20
														MED-HI	3-1/2" X 7"	2-1/2	0.50
NV3-123	40F5	-	124,000	144,976 (1.04)	83.0	Delavan 0.85 X 60° A/B/W	150	7-3/4"	2	2.6	-0.02	410		MED	3-1/4" X 8"	3-1/2	0.20
														MED	3-1/2" X 7"	3-1/2	0.50

Model	Riello Burner	SVS	B.T.U.H. Output	B.T.U.H. Input (USGPH)	AFUE %	Nozzle	Pump p.s.i.	Insertion inches	Burner Air Setting		Chimney Flue Pressure (in w.c.)	Gross Stack °F	Filter Size (qty)	Direct Drive	Belt Drive		External Static Pressure (in w.c.)
									12" Blower	Pulley Combination				Turns Open			
NV3-155V	BF5	Yes	156,000	184,008 (1.32)	82.1	Delavan 1.10 X 60° A/B/W	145	7-3/4"	2	5	-0.02	500	16" X 25" (1) 20" X 25" (1)	HI	3-1/4" X 8"	1-1/2	0.20
														HI	3-1/2" X 7"	2-1/2	0.50
NV3-142V	BF5	Yes	143,000	167,280 (1.20)	81.0	Delavan 1.00 X 60° A/B/W	145	7-3/4"	2	4.5	-0.02	455		MED-HI	3-1/4" X 8"	2	0.20
														MED-HI	3-1/2" X 7"	2-1/2	0.50
NV3-121V	BF5	Yes	122,000	142,188 (1.02)	83.0	Delavan 0.85 X 60° A/B/W	145	7-3/4"	2	4.2	-0.02	410		MED	3-1/4" X 8"	3-1/2	0.20
														MED	3-1/2" X 7"	3-1/2	0.50

Models with the suffix V are certified and listed for use with the Newmac SVS sealed direct vent system

Use burner air settings as a guide only. Set burner air to give a trace of smoke. Re-adjust burner air to reduce CO<sub>2</sub> by 1 to 1.5 percent. Take measurements with the burner cover & air ducts installed (if any).

The maximum allowable temperature rise is 85° F. Select speed to suit specific installation requirements. Air temperature can be lowered by the blower speed; lowering the firing rate; or increasing supply & return outlets.

The minimum recommended temperature rise is 65° F.

\*Maximum installed vent length 15'

**FIG. 2D - GENERAL INSTRUCTIONS – NV3 (continued)**

Model	Aero Burner	SVS	B.T.U.H. Output	B.T.U.H. Input (USGPH)	AFUE %	Nozzle	Pump p.s.i.	Insertion inches	Burner Air Setting		Chimney Flue Pressure (in w.c.)	Gross Stack °F	Filter Size (qty)	Direct Drive	Belt Drive		External Static Pressure (in w.c.)
									12" Blower	Pulley Combination				Turns Open			
NV3-176	HF-US-3	-	177,000	209,100 (1.50)	80.4	Delavan 1.50 X 70° A Monarch 1.50 X 70° NS	100	7-7/8"			-0.02	540	16" X 25" (1) 20" X 25" (1)	HI	3-1/4" X 8"	1/2	0.20
														HI	3-1/2" X 7"	1-1/2	0.50
NV3-158	HF-US-3	-	164,000	188,190 (1.35)	82.1	Delavan 1.35 X 70° A Monarch 1.35 X 70° NS	100	7-7/8"		-0.02	500	HI		3-1/4" X 8"	1-1/2	0.20	
												HI		3-1/2" X 7"	2-1/2	0.50	
NV3-147	HF-US-3	-	151,000	174,250 (1.25)	81.0	Delavan 1.25 X 70° A Monarch 1.25 X 70° NS	100	7-7/8"		-0.02	465	MED-HI		3-1/4" X 8"	2	0.20	
												MED-HI		3-1/2" X 7"	2-1/2	0.50	
NV3-117	HF-US-3	-	120,000	139,400 (1.00)	83.0	Delavan 1.00 X 70° A Monarch 1.00 X 70° NS	100	7-7/8"		-0.02	400	MED		3-1/4" X 8"	3-1/2	0.20	
												MED		3-1/2" X 7"	3-1/2	0.50	

Model	Aero Burner	SVS	B.T.U.H. Output	B.T.U.H. Input (USGPH)	AFUE %	Nozzle	Pump p.s.i.	Insertion inches	Burner Air Setting		Chimney Flue Pressure (in w.c.)	Gross Stack °F	Filter Size (qty)	Direct Drive	Belt Drive		External Static Pressure (in w.c.)
									12" Blower	Pulley Combination				Turns Open			
NV3-175	F-AFC-3	-	177,000	209,100 (1.50)	80.4	Delavan 1.50 X 70° A Monarch 1.50 X 70° NS	100	7-7/8"			-0.02	540	16" X 25" (1) 20" X 25" (1)	HI	3-1/4" X 8"	1/2	0.20
														HI	3-1/2" X 7"	1-1/2	0.50
NV3-157	F-AFC-3	-	164,000	188,190 (1.35)	82.1	Delavan 1.35 X 70° A Monarch 1.35 X 70° NS	100	7-7/8"		-0.02	500	HI		3-1/4" X 8"	1-1/2	0.20	
												HI		3-1/2" X 7"	2-1/2	0.50	
NV3-146	F-AFC-3	-	151,000	174,250 (1.25)	81.0	Delavan 1.25 X 70° A Monarch 1.25 X 70° NS	100	7-7/8"		-0.02	465	MED-HI		3-1/4" X 8"	2	0.20	
												MED-HI		3-1/2" X 7"	2-1/2	0.50	
NV3-116	F-AFC-3	-	120,000	139,400 (1.00)	83.0	Delavan 1.00 X 70° A Monarch 1.00 X 70° NS	100	7-7/8"		-0.02	400	MED		3-1/4" X 8"	3-1/2	0.20	
												MED		3-1/2" X 7"	3-1/2	0.50	

Model	Carlin Burner	SVS	B.T.U.H. Output	B.T.U.H. Input (USGPH)	AFUE %	Nozzle	Pump p.s.i.	Insertion inches	Burner Air Setting		Chimney Flue Pressure (in w.c.)	Gross Stack °F	Filter Size (qty)	Direct Drive	Belt Drive		External Static Pressure (in w.c.)
									Positioning Bar	Air Band				12" Blower	Pulley Combination	Turns Open	
NV3-174	EZ-1	---	177,000	209,100 (1.50)	80.4	Delavan 1.50 X 70° A Monarch 1.50 X 70° NS	100	7-7/8"	1.35 / 1.50	1.50	-0.02	540	16" X 25" (1) 20" X 25" (1)	HI	3-1/4" X 8"	1/2	0.20
														HI	3-1/2" X 7"	1-1/2	0.50
NV3-156V	EZ-1	Yes	164,000	188,190 (1.35)	82.1	Delavan 1.35 X 70° A Monarch 1.35 X 70° NS	100	7-7/8"	1.35 / 1.50	1.35	-0.02	500		MED-HI	3-1/4" X 8"	1-1/2	0.20
														HI	3-1/2" X 7"	2-1/2	0.50
NV3-145V	EZ-1	Yes	151,000	174,250 (1.25)	81.0	Delavan 1.25 X 70° A Monarch 1.25 X 70° NS	100	7-7/8"	1.10 / 1.25	1.25	-0.02	465		MED-HI	3-1/4" X 8"	2	0.20
														MED-HI	3-1/2" X 7"	2-1/2	0.50
NV3-115V	EZ-1	Yes	120,000	139,400 (1.00)	83.0	Delavan 1.00 X 70° A Monarch 1.00 X 70° NS	100	7-7/8"	0.85 / 1.00	1.00	-0.02	400		MED	3-1/4" X 8"	3-1/2	0.20
														MED	3-1/2" X 7"	3-1/2	0.50

Models with the suffix V are certified and listed for use with the Newmac SVS sealed direct vent system

Use burner air settings as a guide only. Set burner air to give a trace of smoke. Re-adjust burner air to reduce CO<sub>2</sub> by 1 to 1.5 percent. Take measurements with the burner cover & air ducts installed (if any).

The maximum allowable temperature rise is 85° F. Select speed to suit specific installation requirements. Air temperature can be lowered by the blower speed; lowering the firing rate; or increasing supply & return outlets.

The minimum recommended temperature rise is 65° F.



### NV2-5 BLOWER PERFORMANCE

DIRECT DRIVE BLOWER	BLOWER MOTOR	SPEED TAP	RPM	STATIC PRESSURE (IN W.C.)	CFM	A/C TONS
DELHI G12-10 DD	3/4 HP 5 SPD	HIGH	1,075	0.50	2,000	5.00
		MED-HI	900		1,500	3.75
		MEDIUM	815		1,200	2.75
		MED-LO	750		1,000	2.50
		LO	690		800	2.00
DELHI G12-10 DD	3/4 HP 5 SPD	HIGH	1,025	0.20	2,300	
		MED-HI	800		1,700	
		MEDIUM	685		1,300	
		MED-LO	630		1,150	
		LO	550		950	

### NV2 BLOWER PERFORMANCE

DIRECT DRIVE BLOWER	BLOWER MOTOR	SPEED TAP	RPM	STATIC PRESSURE (IN W.C.)	CFM	A/C TONS
DELHI G10-8 DD	1/2 HP 4 SPD	HIGH	1,050	0.50	1,400	3.50
		MED-HI	950		1,200	3.00
		MED-LO	880		1,000	2.50
		LO	810		800	2.00
DELHI G10-8 DD	1/2 HP 4 SPD	HIGH	1,030	0.20	1,600	
		MED-HI	950		1,400	
		MED-LO	800		1,175	
		LO	650		875	

BELT DRIVE BLOWER	BLOWER MOTOR	PULLEY TURNS OPEN	RPM	STATIC PRESSURE (IN W.C.)	CFM	A/C TONS
DELHI G10, LAU 1010 or TORIN BC1020	1/2 HP 6 x 3-1/2"	1	965	0.50	1,450	3.50
		2	925		1,275	3.00
		3	875		1,125	2.75
		4	830		925	2.00
DELHI G10, LAU 1010 or TORIN BC1020	1/3 HP 7 x 3-1/4"	0	790	0.20	1,375	
		1	750		1,250	
		2	710		1,050	
		3	670		950	
		4	610		800	

### NV3 DIRECT DRIVE BLOWER PERFORMANCE

DIRECT DRIVE BLOWER	BLOWER MOTOR	SPEED TAP	RPM	STATIC PRESSURE (IN W.C.)	CFM	A/C TONS
DELHI G12-9 DD	3/4 HP 5 SPD	HIGH	1,050	0.50	2,050	5.00
		MED-HI	875		1,525	3.75
		MEDIUM	800		1,225	2.75
		MED-LO	750		1,075	2.50
		LO	700		850	2.00
DELHI G12-9 DD	3/4 HP 5 SPD	HIGH	1,000	0.20	2,200	
		MED-HI	750		1,525	
		MEDIUM	650		1,250	
		MED-LO	600		1,100	
		LO	550		900	

### NV3 BELT DRIVE BLOWER PERFORMANCE

BELT DRIVE BLOWER	BLOWER MOTOR	PULLEY TURNS OPEN	RPM	STATIC PRESSURE (IN W.C.)	CFM	A/C TONS
DELHI G12, LAU A12-12 OR TORIN BC1220	3/4 HP 7 x 3-1/2"	1/2	875	0.50	2,200	5.50
		1-1/2	840		1,900	4.75
		2-1/2	780		1,650	4.00
		3-1/2	730		1,350	3.25
		4-1/2	680		1,050	2.50
DELHI G12, LAU A12-12* OR TORIN BC1020*	1/2 HP* 8 x 3-1/4"	1/2	690	0.20	1,900	
		1-1/2	650		1,775	
		2-1/2	600		1,600	
		3-1/2	550		1,325	
		4-1/2	500		1,050	

\*Note: Lau and Torin blowers require a 3/4 hp belt drive motor for oil inputs of 1.50 USGPH and above.

# INSTALLATION

## INSTALLATION REGULATIONS

This unit should be installed in accordance with the regulations of the authority having jurisdiction. In Canada the installation must conform to CSA Standard B139, "The Installation Code for Oil Burning Equipment." In the United States, the National Fire Protection Association Standard NFPA 31 should be followed. Check with provincial, state, or local codes concerning clearances, chimney requirements and other regulations governing installation. The unit must also be installed in accordance with the National Warm Air Heating and Air Conditioning Association Standards or generally accepted equivalent standards. Some codes may vary from the requirements set forth in this manual. All components and ancillary equipment should be marked CSA Certified or UL Listed.

## FOUNDATION

To ensure the furnace is on a level foundation and above any possible dampness, a cement pad is recommended.

## CLEARANCES

The minimum clearances are as follows:

	NL2/NL3/NLF/NMR	NV2	NV3
Top of Plenum	2"	1"	1"
Side	6"	6"	6"
Other Side (Walkway)	24"	18"	24"
Front	24"	24"	24"
Rear	30" or sufficient room for servicing	18" or sufficient room for servicing	30" or sufficient room for servicing
Flue	9"	9"	9"
Approved Floor Type	Non Combustible	Non Combustible	Non Combustible

**FOR YOUR SAFETY: DO NOT STORE OR USE GASOLINE OR FLAMMABLE VAPORS AND LIQUIDS IN THE VICINITY OF THIS OR ANY OTHER APPLIANCE.**

## PROPER CHIMNEY

Locate the furnace as close to the chimney or flue as possible. The maximum draft will be obtained by keeping elbows and pipe length to a minimum. Install the flue pipe with a gradual rise of at least 1/4" per foot from the furnace to the flue. Do not extend the flue pipe beyond the inside wall of the chimney. Refer to Fig.12 for proper sizing and Fig. 16 for optimizing chimney draft.

The owner shall provide a chimney constructed to comply with the following specifications:

- (a) The chimney must be absolutely smoke tight throughout its entire length, and must extend at least three feet (3') above a flat roof or two feet above the ridges of peak roofs.
- (b) If built of a single thickness of brick or of cement blocks, it shall be lined throughout its entire length with fire clay lining, having not less than three-fourths inch (3/4") thickness. Flue lining is to be laid in mortar and made air tight. If the chimney is of the prefabricated type, it must be an approved class "A" chimney or type "L" Vent for interior.
- (c) The chimney or furnace flue must not have any other openings for attaching any fireplace, stove, range, gas or ventilating connection unless that equipment is appropriately certified.
- (d) If it is necessary to offset the flue, it must be done in such a manner as not to reduce the gross cross-sectional area or create a ledge or obstruction, where loose material may lodge.
- (e) Flue pipe connections must be secured with metal screws. Make sure the flue pipe does not extend inside the furnace blower compartment.

**CAUTION: Oil-fired appliances shall be connected to flues having sufficient draft at all times to ensure safe and proper operation of the appliance.**

## THROUGH THE WALL VENTING

Newmac Oil Furnaces are certified for use with Field Controls SWG-5 Through the Wall Venter. The following furnaces have approval at the following firing rates :

<u>FURNACE MODEL</u>	<u>FIRING RATE</u>
NL2	.65 – 1.00
NLF	.65 – 1.00
NMR	.65 – 1.00
NL3	1.00 Only

**DRAFT REGULATOR**

The draft regulator is shipped with the furnace. The draft regulator must be installed between the appliance and the chimney, within easy reach for adjustment and free from obstruction. The recommended draft is -0.02" of water column. Follow the manufacturer’s instructions located with the draft regulator for proper installation.

**PROPER DUCT SIZING**

Locate the furnace as close as possible to the center of the heat distribution system and make sure the top is level. Refer to the DUCT SIZING TABLES FOR DUCT SYSTEMS – Fig. 13.

**ELECTRICAL CONNECTIONS**

See certification label for electrical rating. Follow the National Electrical Code as well as provincial, state, and local regulations. Fig. 11 shows wiring schematics.

**FUEL SYSTEMS**

Fuel not heavier than No. 2 furnace oil must be used. The oil tank must be of an approved type - ULC labelled in Canada and ULI labelled in the United States. Install the oil storage tank or tanks according to local codes and regulations. The supply tank should be kept at least 1/4 full. Suction and return lines should be of the same diameter and extend to the same depth in the tank. Suction line should be looped to reduce vibration when copper line is connected directly to oil pump. An emergency oil shut-off valve should be installed as required by local ordinance. This can be manual, electric solenoid, or vacuum operated. An oil safety valve that cuts the fuel supply unless a vacuum is created by the pump recommended. Any leaks in the system will prevent oil from flowing. Suntec PRV or Webster OSV valves are recommended.

**COMBUSTION AIR REQUIREMENTS**

Free air for combustion and ventilation must be permanently provided to the furnace room. Combustion air refers to the total air requirements of the fuel-burning appliance. This includes air for the combustion process and air to provide chimney draft (dilution air). Ventilation air provides free circulation of air in the room where the appliance is located to keep ambient temperatures within safe limits under normal conditions.

Furnaces installed in tight houses, in houses which have air-handling devices with unbalanced airflows, or in enclosed spaces are very likely to have homeowners complain of smoke, fumes, burner lockouts, and excessive fuel consumption. This is more prevalent in post 1985 construction due to the tighter building construction as prescribed by the latest building codes. Regulations are relatively specific on the minimum allowable quantities of ventilation and combustion air required once the space category is determined. However, every house is subject to different internal and external conditions and regulations vary among localities. With this in mind, Newmac recommends provision for combustion and ventilation air as specified in Fig. 3. Fig. 3 is based on relevant commonly available codes and regulations.

Values are based on the maximum input rating for this single appliance. However, in making combustion and ventilation analysis the aggregate input rating of all appliances in the space must be considered. The installation of additional oil-fired appliances may require more combustion and ventilation air. When sizing combustion and ventilation air ducts, allowance must also be made for the blocking effect of louvers, grilles and screens. If the design and free area is unknown, wood louvers generally have 20-25% free area and metal louvers or grilles have 60-75% free area. Screens should not be less than 1/4 inch mesh.

**FIG. 3 - COMBUSTION & VENTILATION AIR SIZING**

Appliance	Floor Area (square feet)	Space Category	Vertical Ducts & Direct Opening Sizes			Horizontal Duct Sizes (in.)		
			Free Area (in. <sup>2</sup> )	L X W (QTY) (in. X in.)	Dia. (QTY) (in.)	Free Area (in. <sup>2</sup> )	L X W (QTY) (in. X in.)	Dia.(QTY) (in.)
NMR, NL2 NLF, NV2	More than 725	Unconfined	30	4 X 8 (1)	6 (1)	30	4 X 8 (1)	6 (1)
	725 or less	Confined	72	4 X 9 (2)	7 (2)	145	4 X 8 (2)	10 (2)
NL3, NV3	More than 725	Unconfined	42	6 X 7 (1)	8 (1)	42	6 X 7 (1)	8 (1)
	725 or less	Confined	105	7 X 8 (2)	8 (2)	210	11 X 10 (2)	12 (2)

Notes: Minimum combustion air requirements may be specified on the appliance certification label.

comairreqnl205062006.xls

The following should be kept in mind when using Fig. 3:

- All applicable codes and regulations must be followed.
- Free duct area is for ducts and opening to outdoors.
- Unconfined free area values are based on 1 sq. in per 5,000 Btu/hr of the maximum input rating.
- Confined free area of vertical ducts is based on 1 sq. in per 4,000 Btu/hr of the maximum input rating.
- Confined free area of horizontal ducts is based on 1 sq. in per 2,000 Btu/hr of the maximum input rating.
- Two openings of equal size are required for confined spaces.
- Maximum length of run for ducts is 50 ft. Duct size allowances must be made for longer runs.
- Ducts should be designed or insulated to prevent condensation. If insulating, a minimum insulation value of R-3 is required.
- In the case where one opening or duct is specified and combustion and ventilation air is still inadequate, a second duct may be required. Locate one high and the other low for air circulation.

It is particularly important to duct the cold air as close to the appliance as possible. A means of closing the air openings when the appliance is not operating may be required. Except for an SVS sealed vent installation, outside air ducts should not be connected either to the burner or to the appliance.

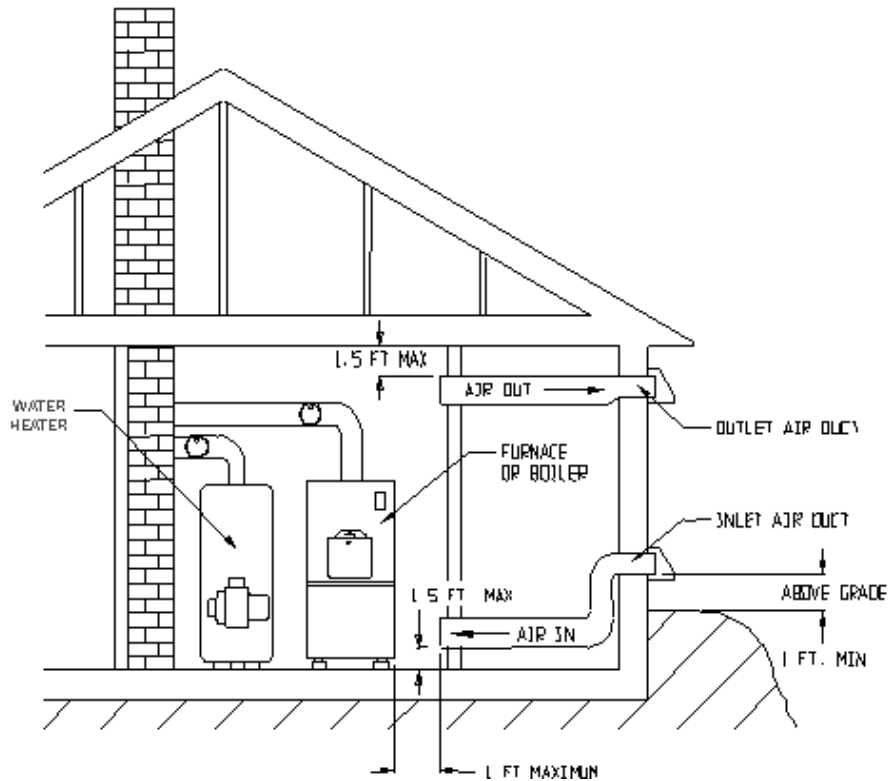
Guidelines to determine the need for additional combustion and ventilation air may not be adequate for every situation. If in doubt, it is advisable to err on the safe side and provide additional air.

Fig. 4 shows a typical appliance installation. In this case there is a furnace and a water heater in an enclosed space--both require ventilation and combustion air which is delivered by the top and bottom air ducts.

As long as adequate combustion and ventilation air is supplied, the confined appliance room with ducted air offers several advantages:

- The incoming cold air is confined to the furnace room. Therefore, the residence occupants are less susceptible to drafts. Cool outdoor air will be tempered by the ambient temperature of the furnace room before it enters habitable spaces.
- Noise levels may be reduced.
- The furnace will be less susceptible to combustion spillage and back-drafting in low draft situations reducing odor and smoke. Moderate amounts of smoke and fumes will be contained and expelled safely outdoors.
- Incomplete combustion of any carbon-based fuel may produce deadly carbon monoxide. Ventilation may dilute any carbon monoxide produced under abnormal operating conditions.
- Adequate air for combustion will help maintain the proper air-fuel ratio. Appliances, which are burning fuel rich, will produce soot and burn excessive fuel. A 1/8 inch thick deposit of soot on the surface of the heat exchanger is equivalent to 1 inch of fiberglass insulation.
- Modern efficient oil burning appliances tend to be physically smaller than are their predecessors are. As a result, hot surfaces such as those on flue connectors are not as high off the ground or floor as they used to be. A separate furnace room with a "child proof" door is an important safety precaution.

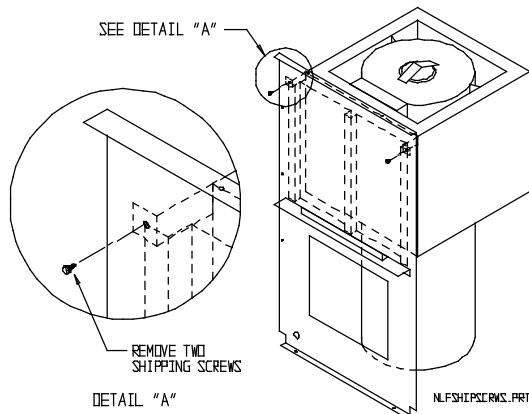
**FIG. 4 - APPLIANCE LOCATED IN CONFINED SPACE WITH ALL AIR FROM OUTDOORS**



**COMBUSTION CHAMBER**

Make sure the combustion chamber was not damaged during shipping. If replacement of the combustion chamber becomes apparent, instructions are available from the manufacturer.

**FIG.5 - NLF MODEL: REMOVE SHIPPING SCREWS**



**AIR CONDITIONING**

This furnace is designed to accommodate air conditioning equipment. It is factory wired for single speed heating only. Conversion to heating-cooling on direct drive models requires an optional fan relay, thermostat, and thermostat subbase. Refer to the wiring diagram for multi-speed air conditioning found in this manual or the label inside the blower access door. For cooling capacity, select the required speed on the motor. Take care not to short the speed connections. This will damage the motor and void the warranty. The GENERAL INSTRUCTIONS section of this manual and the label inside the blower access door give recommended pulley combinations and direct speeds required to handle the higher duct static pressures associated with air conditioning units.

**HUMIDIFIER**

If a humidifier is installed, ensure water cannot drip on the heat exchanger. This will damage the furnace and void the warranty.

## OIL BURNER OPERATING INSTRUCTIONS

### BURNER CARE

This burner is fully automatic in operation. All adjustments should be made by a qualified technician. Keep the burner free from excess dirt and moisture. Oil leaks should be tended to immediately. The motor should be given a few drops of SAE 20 non-detergent oil at least two or three times a year if equipped with oil plugs. No other parts require lubrication.

**CAUTION:** *Do not use gasoline, crankcase or any oil containing gasoline. Do not tamper with the unit or controls - call the serviceman. Do not attempt to start the burner when excess oil has accumulated, when the unit is full of vapor or when the combustion chamber is very hot. Do not start the burner unless the blower access door is secured in place. Do not burn garbage or paper in the heating system. Never leave paper or rags near the unit.*

### OIL BURNER INSTALLATION

Install the oil nozzle in the burner firing assembly, and check the adjustments according to the BURNER INFORMATION, CERTIFICATION LABEL and GENERAL INSTRUCTIONS in the manual for your particular burner. Set the blast tube to the correct insertion length as specified in the GENERAL INSTRUCTIONS, FIG.6 AND THE CERTIFICATION LABEL. Mount the oil burner on the lugs of the burner plate carefully centering it in the combustion chamber port. If the insertion is correct, the end of the blast tube should be no more than 3/8" back from the inside of the surface of the combustion chamber. Riello burners are equipped with a 3-1/3" diameter blast tube. To compensate for this a ceramic fibre sleeve needs to be used. It should be flush with the end of the burner tube or extend not more than 1/4" beyond the end of the tube. Carefully install the burner to avoid damaging the sleeve and the chamber.

## START-UP AND ADJUSTMENT

### SET-UP INSTRUMENTS

It is recommended the installer have a suitable draft gauge, smoke tester, carbon dioxide tester, 0-750 F stack thermometer, 0-200 psi oil pressure gauge, 0-30 in. Hg. vacuum gauge, and 0-220 F thermometer.

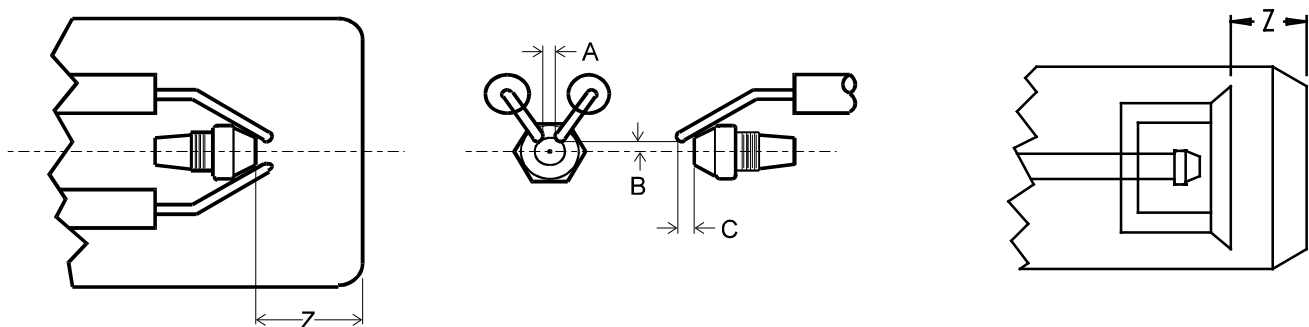
1. Turn on supply power and set the thermostat above room temperature.
2. Open all oil lines and valves.
3. Bleed the oil pump (refer to pump manufactures instructions).
4. Adjust the air band on the burner until a # 1 smoke or less is reached using a smoke tester. Slowly increase the air until a small amount of smoke is observed at the flame tips.

-If the burner fails to start, check: (a) oil supply; (b) ignition electrodes and transformer; (c) cad cell.

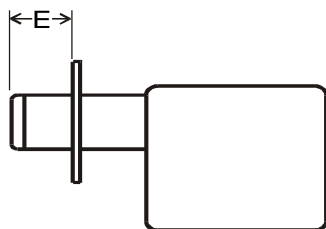
-If the burner goes off on safety, do not push the reset button on the primary control for at least 10 minutes. **Do not push the reset button more than once before correcting the cause.** If the burner still does not start, press the reset on the burner motor.

5. Using a draft meter, adjust the barometric draft regulator to measure -0.02 inch water column. This requires that a 5/16" diameter sampling hole be made between the flue collar and the draft regulator.

FIG. 6A - ELECTRODE SETTINGS



**FIG. 6B - BURNER INSERTION**



**FIG. 6C - DIMENSIONAL RELATIONSHIPS**

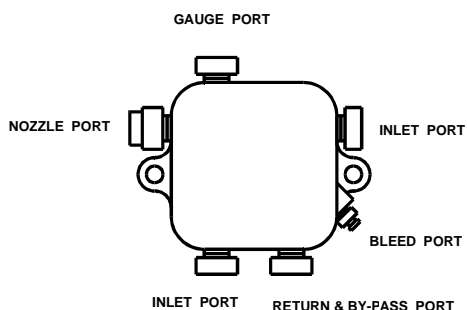
	Riello				Beckett AFG		Aero	Carlin
	F3	F5	BF3	BF5			HF-US	EZ-1
A	5/32"				5/32"	5/32"	1/8"	1/8" to 5/32"
B	13/64"				7/16"	7/16"	7/32"	5/16"
C	5/64" to 7/64"				1/16"	1/16"	1/8"	1/16"
Z	Refer to Turbulator Setting				1-3/8"	1-3/4"	1-1/8"	Use Positioning Bar
E	See General Instructions & Certification Label for Insertion							

**BURNER OIL PRESSURE CHECK**

Install the pressure gauge directly on the gauge or nozzle port. Adjust to the pressure specified by Newmac for the nozzle input rating. Refer to **GENERAL INSTRUCTIONS** in this manual or the certification label on the appliance.

Each oil burner should have its own suction line. A common return line can be used as long as the diameter is large enough. Check valves are not required on properly installed systems. Service on fuel units should not be attempted without a suitable vacuum and pressure gage.

**FIG. 7 - TYPICAL OIL PUMP**



**SEASONAL OR EXTENDED SHUT DOWN PERIODS**

When the burner is not to be used for an extended period of time, set the thermostat at its lowest value, turn off the main switch and close the oil burner supply valve. If the heating unit room is damp, protect the burner against dirt and moisture with a light cover. To resume operation, remove the cover and inspect the burner. Remove any dirt and debris gently to avoid the need to adjustment the air band. Open the supply valve and turn on the main switch. If the burner fails to operate see Fig. 17.

**BLOWER ADJUSTMENT**

This unit is designed for a maximum temperature rise through the furnace of 85° F at 0.20" and 0.50" static pressures. However, due to the wide range of static pressures found in duct systems, it is the responsibility of the installer to obtain a temperature rise of no more than 85°F. To determine the actual temperature rise let the unit operate for at least five minutes. Insert a thermometer and note the temperature of the warm air supply at a point at least 24" upstream from the heat exchanger surface. Next measure the temperature at the return air grill and take the difference. Air temperature rise can be lowered by increasing the blower speed, lowering the firing rate, or increasing supply or return outlets. Use the airflow data given in the General Instructions as a guide only. The furnace will not operate properly and its life will be decreased if not enough air passes over the heat exchanger.

**Belt Drive Models**

The air delivery (CFM) and temperature rise can be varied by adjusting the motor pulley. Closing the pulley increases blower speed (decreases temperature rise), while opening the pulley decreases blower speed (increases temperature rise). Pulley combinations vary according to the nozzle size and duct static pressure. Recommended pulley combinations are found in Fig. 2 - GENERAL INSTRUCTIONS section of this manual and on a label inside the access door. Misalignment of the motor and blower pulley may result in excessive noise. Correct belt tension



allows 1" of flexing midway between the pulleys. Too much tension will overload the motor - too little will cause slippage. Premature belt wear will result from incorrect belt tension or pulley alignment.

**Direct Drive Models**

The motor speed will automatically change over a range of duct static pressures. The motor has multiple speeds - the installer should select the best speed for the specific installation. Recommended speeds are found in Fig.2 - GENERAL INSTRUCTIONS section of this manual and on a label inside the blower access door. The speed can be changed by disconnecting the non-white lead and reconnecting it to another winding speed tap.

**THERMOSTAT**

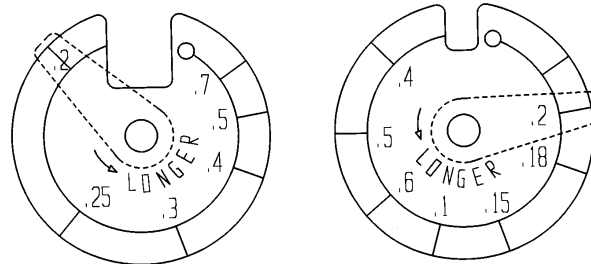
The thermostat should be located on an interior wall free from drafts approximately 5 feet above floor level. The operation of the burner is normally controlled by the room thermostat, which may be set for the temperature desired, typically 70 °F. If a higher or lower temperature is desired, the indicator should be set to the proper point of the scale. To shut down the burner at any time, turn the main power switch off. To prevent short cycling, the heat anticipator should be set as recommended in the specifications for the burner control. This is typically set at 0.2 amps as indicated in Fig.8A. This adjustment shuts the burner down to prevent the room temperature from exceeding the thermostat setting.

**FAN & LIMIT CONTROL**

This thermally operated control prevents dangerous overheating of the furnace by cutting power to the burner when the limit setting is reached. It also keeps the blower from starting until the burner has had sufficient time to warm the furnace. When the call for heat is satisfied, it allows the blower to run after the burner shuts down to cool the furnace. Refer to Fig.8 for the proper Fan Off and Fan On settings. A manual fan switch overrides these settings for continuous operation of the blower. Common faults causing this control to interrupt the power supply to the burner are blower failure, dirty filters, insufficient return air and supply air blockage. Make sure duct sizes meet the minimum requirements and that registers and grills are not covered with rugs.

Fan differential is adjustable between the Fan On and Fan Off settings, with a minimum of 15 deg F (8 deg C). For constant fan operation, push the Manual-Auto switch button to MAN position.

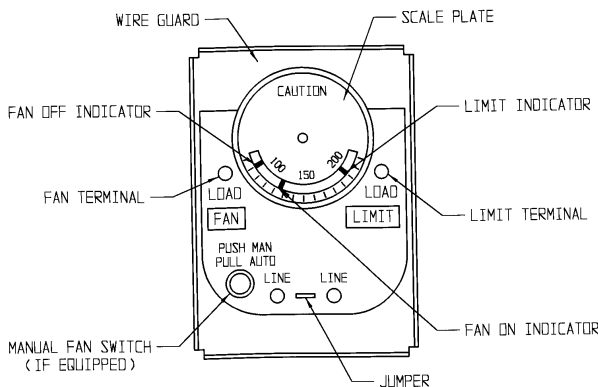
**FIG. 8A - Heat Anticipator**



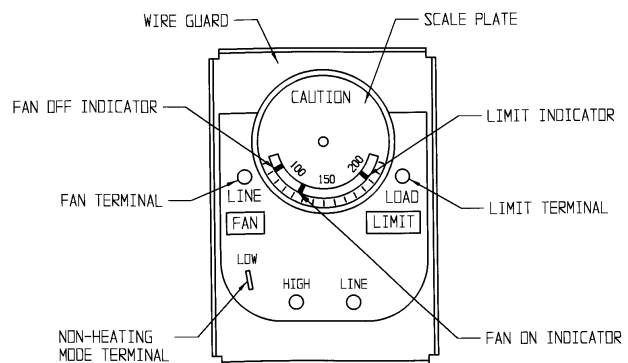
HONEYWELL T822

WHITE ROGERS TF30

**Fan differential (difference between the Fan On & Fan Off settings) should be at least 15°F (8°C).**



**FIG. 8B - TWO SPEED FAN & LIMIT**



**FIG. 8C - SINGLE SPEED FAN & LIMIT**



### **WMO-1 Blocked Vent Switch Check**

Note: take appropriate precautions - this test can produce soot, smoke and fumes. The appliance should not be left unattended during the test.

1. With the appliance shut down, block the vent pipe at the downstream (chimney) side of the barometric damper.
2. Start the appliance.
3. The WMO-1 switch should stop the oil burner in less than 10 minutes.
4. After the test, turn off the appliance and let it cool.
5. Remove the blockage from the vent pipe.
6. Reset the WMO-1 switch by pushing in the square red button until it clicks.
7. Ensure that the appliance is in a safe condition.

**Maintenance and Cleaning – WMO-1 Switch** – The WMO-1 switch assembly should be checked and cleaned at least once a year and after any time the switch has shut off the burner.

Cleaning Procedure:

1. Switch off the electrical power to the appliance.
2. Remove the WMO-1 cover.
3. Remove the two mounting screws for the thermodisc temperature sensor.
4. Carefully pull the sensor to one side.
5. Using a suitable soft brush or cloth carefully clean any soot from the surface of the sensor and the inside of the 5/8" diameter tube.
6. Replace the sensor and secure with its mounting screws.
7. Check that the wiring is in good condition and secure.
8. Check that the 5/8" diameter tube and its securing nuts are tight.
9. Replace the cover and tighten the mounting screws.
10. Check the operation of the WMO-1 switch as described above.

### **Troubleshooting – WMO-1 Switch**

If for any reason the WMO-1 switch shuts the appliance down during operation, the cause of the shut down should be investigated and corrected before resetting the switch and restarting the appliance. The blockage switch is reset by pushing the square red button until it clicks.

## **MAINTENANCE & SERVICE**

Maintenance and service should be done by a qualified burner technician, or shortened furnace life and poor efficiency may result. Under Tests and Observations and Requirements in CSA B139, the installer is required to perform tests to ensure proper and safe operating conditions. Newmac requires the installer to fill out the **INSTALLER INFORMATION** sheet found in this manual.

The heat exchanger should be inspected on an annual basis. If cleaning is required, remove panels to gain access to the cleanout covers - take care not to break gaskets. On some models the wire channel may have to be removed first. Use a wire brush (available from manufacturer) to loosen scale and soot. A vacuum cleaner should be used to remove the scale and soot. Replace gaskets if necessary before replacing the cleanout covers.

### **OIL FILTER**

The oil filter should be cleaned or replaced at least once a year by the serviceman. We recommend General Filters Model GF-CGF10 (refill GF-K10GF).

### **INSTALLATION & REPLACEMENT OF AIR FILTERS**

The air filter should be inspected monthly and changed as required. At least two changes are usually required during the heating season - more may be required if dusty conditions exist. Turn off the main power to the furnace before opening the blower access door. Remove the filter gently if necessary to prevent dust spillage in the blower compartment and install the new one according to the accompanying instruction. The filter size required is found in the **GENERAL INSTRUCTIONS** table of this manual.

Install filters of the same size and type with the correct side facing the blower.

If your furnace is equipped with an electronic air filter, clean it on a regular basis. Disconnect the electrical power and remove the filter completely from the furnace. Remove and install the filter as specified in the instructions for the unit.

### BLOWER REMOVAL

Disconnect power before removing or servicing the blower.

The blower is mounted to the base panel on the rubber isolation dampers with four screws. It is accessible through a panel on the rear of the furnace. With the filters and the mounting screws removed, disconnect the motor leads and ground wire and pull the blower back. Install in reverse order. The four mounting screws should be snug. Do not over tighten or the dampers will compress and vibration may occur.

**FIG. 10 – TYPICAL OIL TANK PIPE INSTALLATIONS**

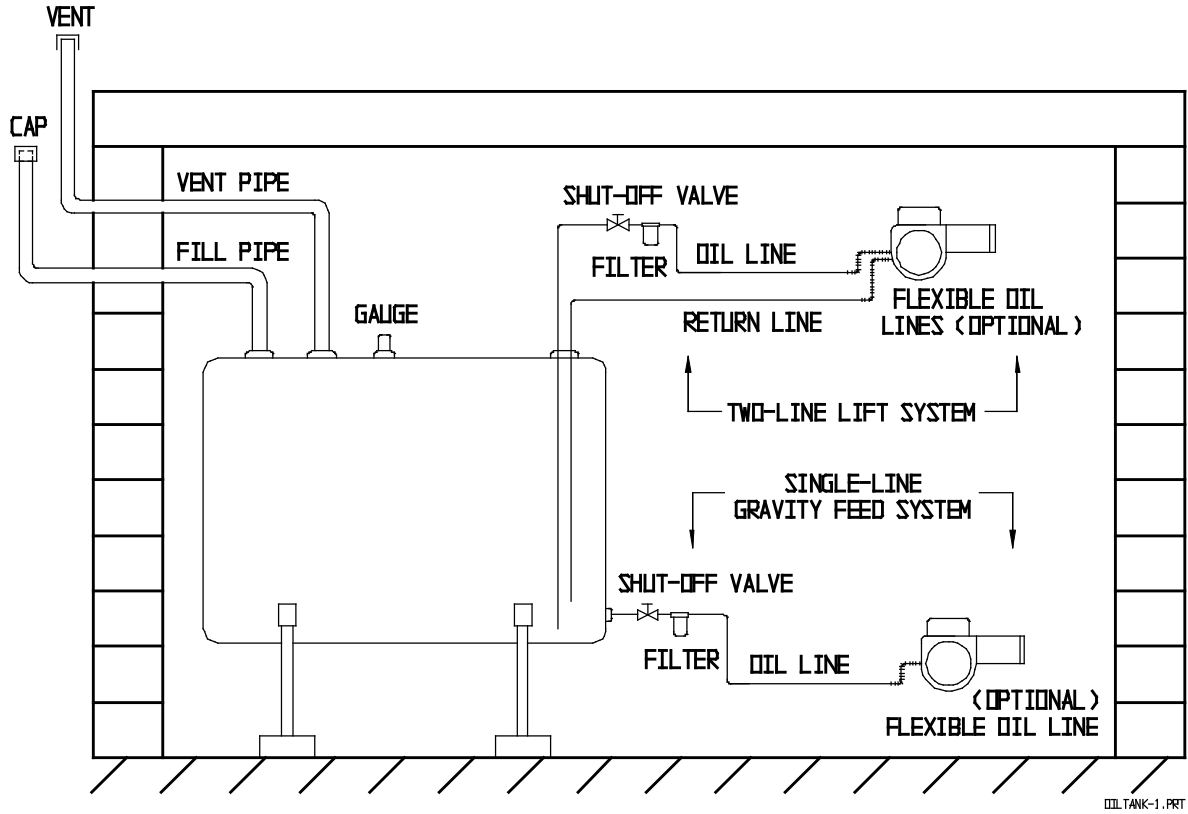
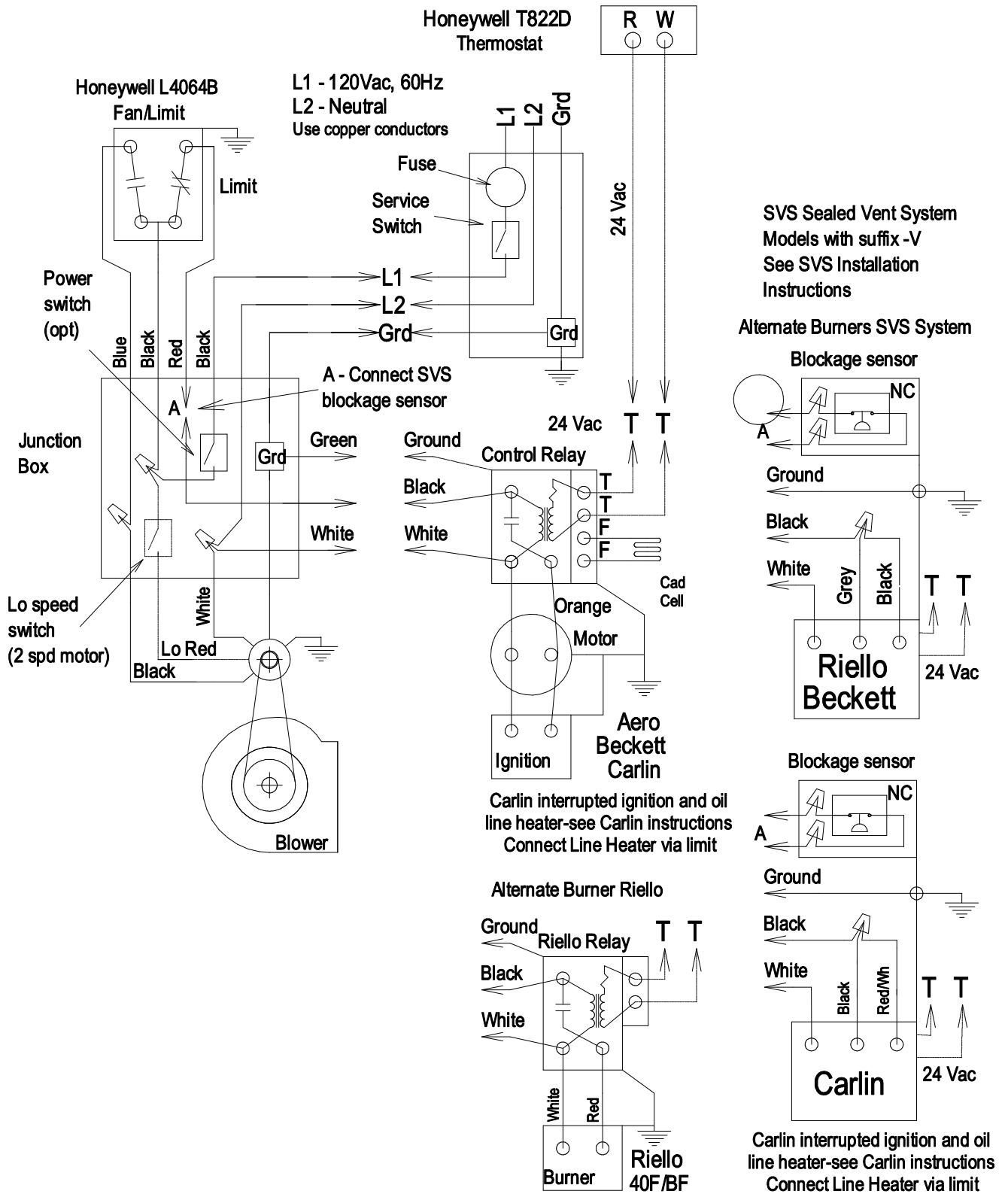
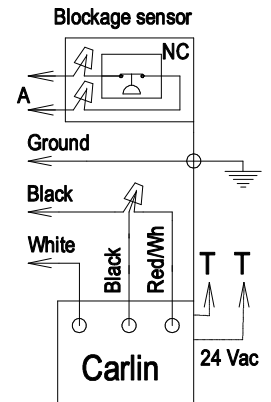
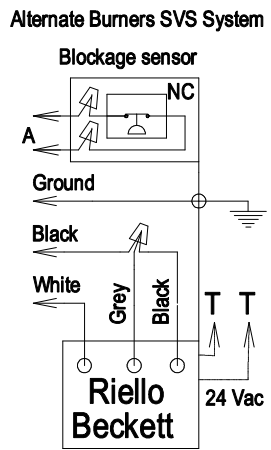
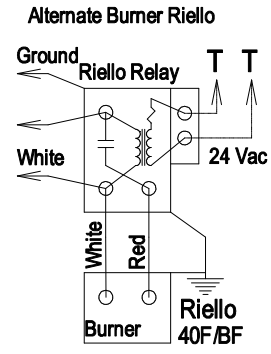
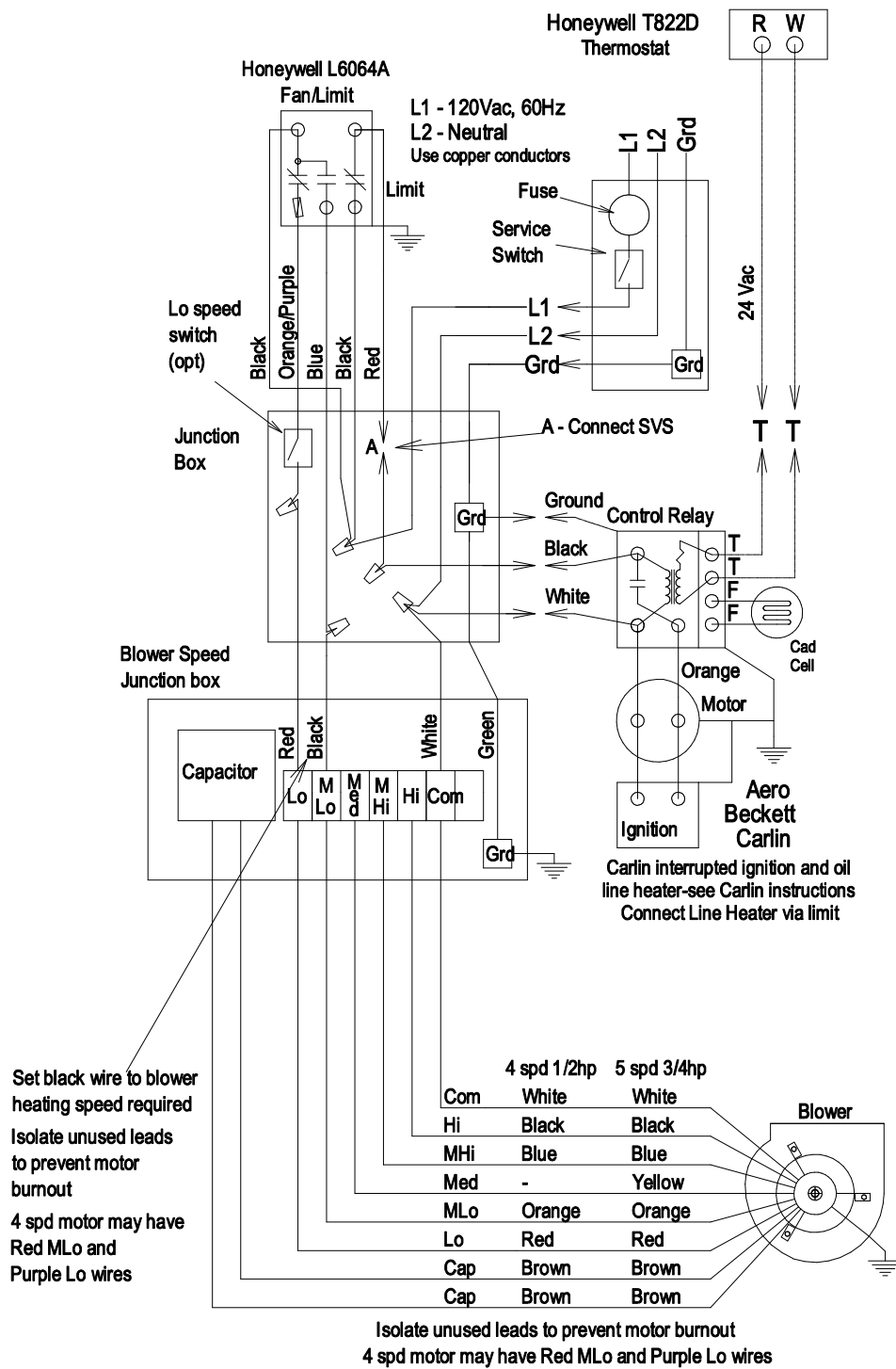


FIG. 11A - STANDARD WIRING - SINGLE SPEED BELT DRIVE



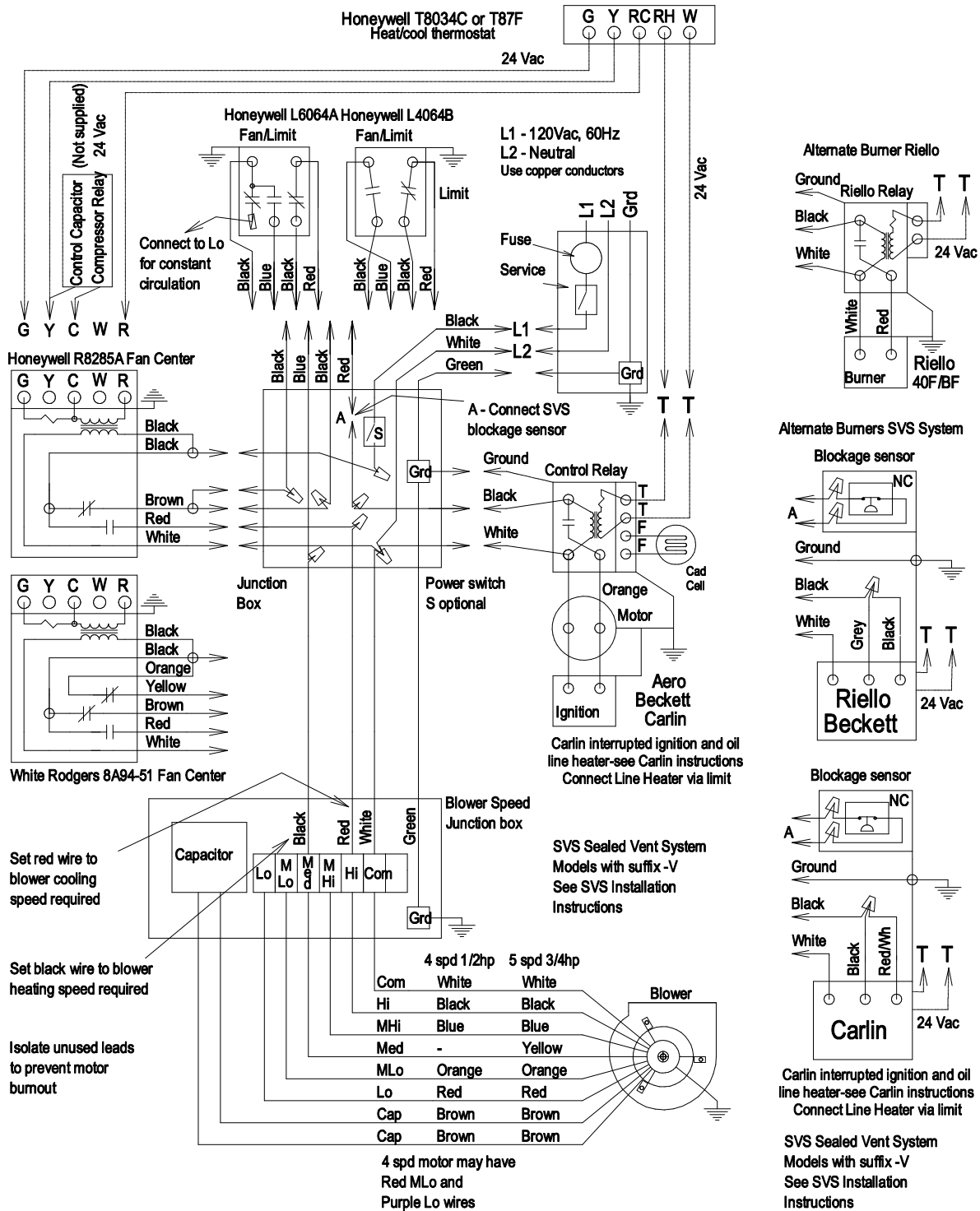
**FIG. 11B - STANDARD WIRING - MULTI SPEED DIRECT DRIVE**



Carlin interrupted ignition and oil line heater-see Carlin instructions  
 Connect Line Heater via limit

**SVS Sealed Vent System**  
 Models with suffix -V  
 See SVS Installation Instructions

**FIG. 11C - STANDARD WIRING SCHEMATIC - A/C READY DIRECT DRIVE**



**FIG. 13A - DUCT SIZING FOR HEATING WITHOUT A/C COIL**

Output Capacity (See Notes)	Min. Air Flow Req'd.	Supply Duct or Extended Plenum @ 800 FPM	Min. Sq. Inch Needed for Spec. CFM (Total Area of All Supply Duct)	Min. Number Supply Runs @ 600 FPM				Minimum Size	
				5" Runs 80 CFM	6" Runs 115 CFM	7" Runs 155 CFM	3 1/2" X 14" 170 CFM	Return Duct Furnace or Air Handler @ 800 FPM	Return Air Grille (or equivalent) @ Face Velocity of 500 FPM
45,000 to 55,000	500 CFM	14" X 8" or 12" round	100	7	5	4	3	14" X 8" or 12" round	12" X 12"
60,000 to 70,000	700 CFM	18" X 8" or 14" round	140	10	6	5	4	18" X 8" or 14" round	24" X 10"
75,000 to 85,000	800 CFM	22" X 8" or 14" round	170	10	7	5	5	22" X 8" or 14" round	24" X 12"
95,000 to 105,000	900 CFM	24" X 8" or 15" round	190	12	8	6	6	24" X 8" or 15" round	24" X 12"
105,000 to 115,000	1100 CFM	22" X 10" or 16" round	220	-	10	7	7	22" X 10" or 16" round	30" X 12"
125,000 to 150,000	1400 CFM	24" X 12" or 18" round	280	-	12	9	8	24" X 12" or 18" round	30" X 14"
155,000 to 160,000	1600 CFM	1 - 35" X 10" or 20" round or 2 - 22" X 8"	360	-	14	10	10	32" X 10" or 20" round	30" X 18"

- Notes:
1. BTUH with maximum temperature rise.
  2. Gas furnaces are rated in input capacity. Rated output capacity is 80 % of input.
  3. Oil and electric furnaces are rated in output capacity.

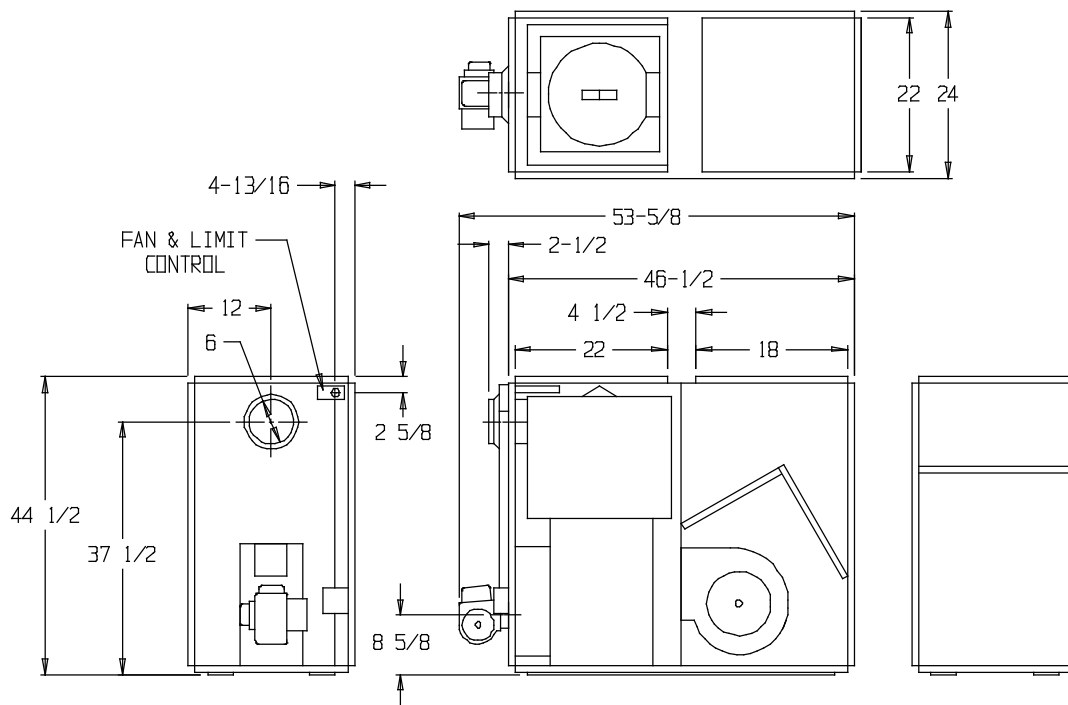
**FIG. 13B - DUCT SIZING FOR HEATING & COOLING WITH A/C COIL IN DUCT**

Air conditioning systems should never be sized on the basis of floor area alone. Knowledge of the approximate floor area (sq. ft.) that can be cooled with a ton of air conditioning will be of invaluable assistance to you in avoiding serious mathematical errors.

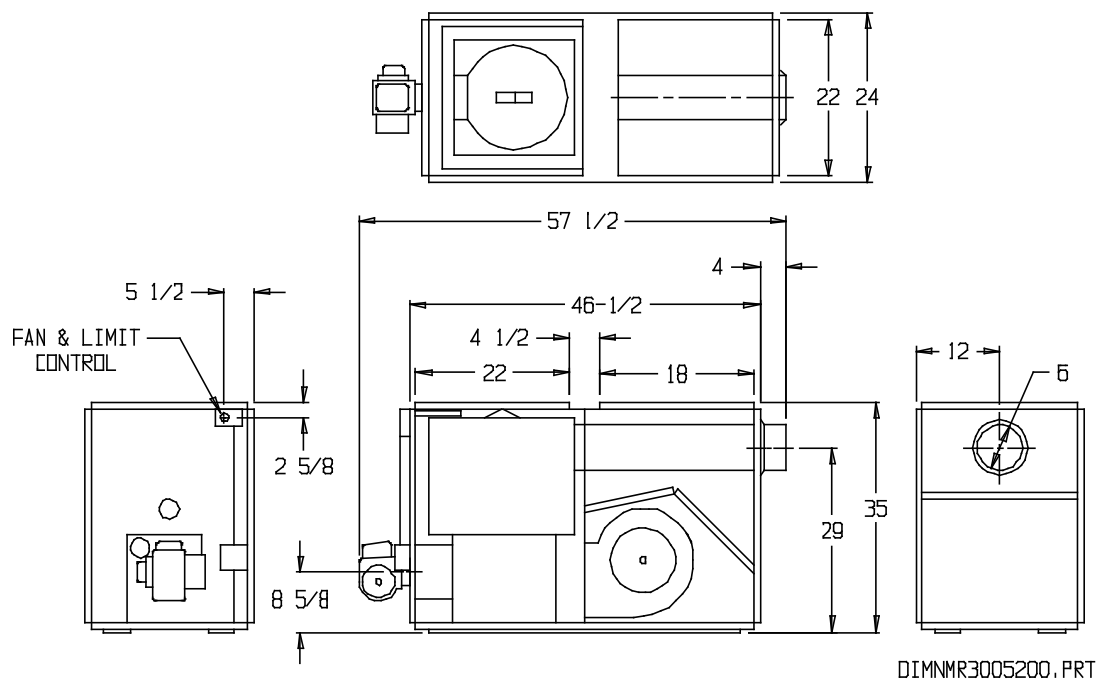
Size of O.D. Unit	Normal Air Flow Req'd @ 400 CFM per Ton	Furnace		Supply Duct or Extended Plenum @ 800 FPM	Min. Number Supply Runs @ 600 FPM				Min. Return Duct Size at Furnace or Air Handler @ 800 FPM	Min. Return Air Grille Size (or equivalent) @ Face Velocity of 500 FPM
		Blower Motor H.P.	Blower Wheel Dia. X Width		5" Runs 80 CFM	6" Runs 115 CFM	7" Runs 155 CFM	3 1/2" X 14" 170 CFM		
1 1/2 ton 18,000 BTUH	600 CFM	1/4 HP	9" X 8" 10" X 8"	16" X 8" or 12" round	8	5	4	4	16" X 8" or 12" round	24" X 8"
2 ton 24,000 BTUH	800 CFM	1/4 HP	9" X 9" 10" X 8"	22" X 8" or 14" round	10	7	5	5	22" X 8" or 14" round	22" X 12"
2 1/2 ton 30,000 BTUH	1000 CFM	1/3 HP	10" X 8" 10" X 10" 12" X 9"	20" X 10" or 16" round	13	9	7	6	20" X 10" or 18" round	30" X 12"
3 ton 36,000 BTUH	1200 CFM	1/3 HP	10" X 8" 10" X 10" 12" X 9"	24" X 10" or 18" round	-	11	8	7	24" X 10" or 18" round	30" X 12"
3 1/2 ton 42,000 BTUH	1400 CFM	1/2 HP 3/4 HP	10" X 8" 10" X 10" 12" X 9" 12" X 10"	24" X 12" or 18" round	-	12	9	8	24" X 12" or 18" round	30" X 14"
4 ton 48,000 BTUH	1600 CFM	1/2 HP 3/4 HP	12" X 7" 12" X 9" 12" X 10" 12" X 12"	32" X 10" or 20" round	-	14	11	10	32" X 10" or 20" round	30" X 18"



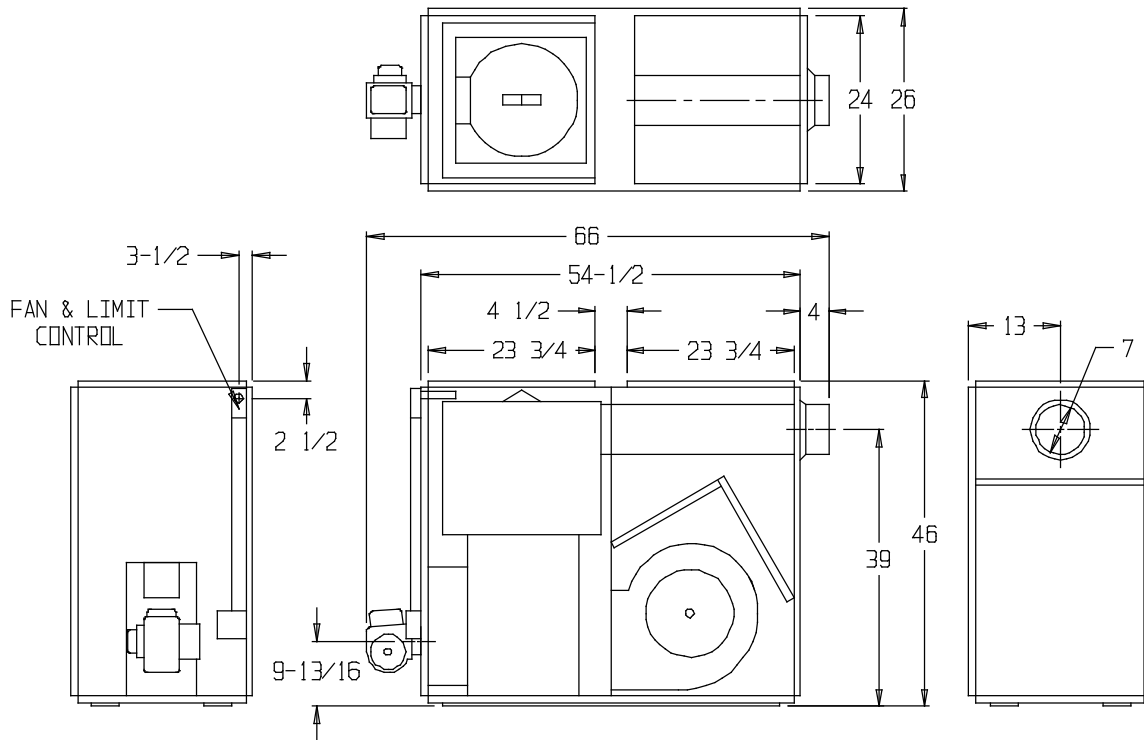
**FIG. 14A - DIMENSIONS & CONTROL LOCATIONS NLF**



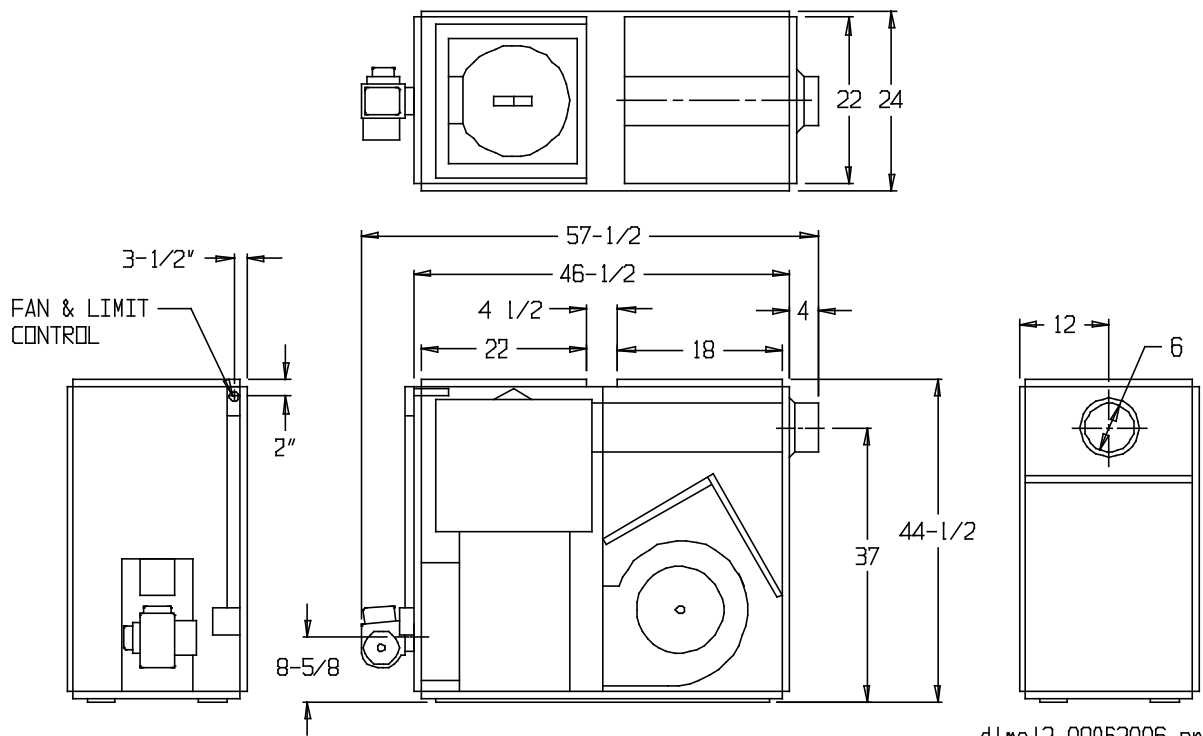
**FIG. 14B - DIMENSIONS & CONTROL LOCATIONS NMR**



**FIG. 14C - DIMENSIONS & CONTROL LOCATIONS NL3/NV3**

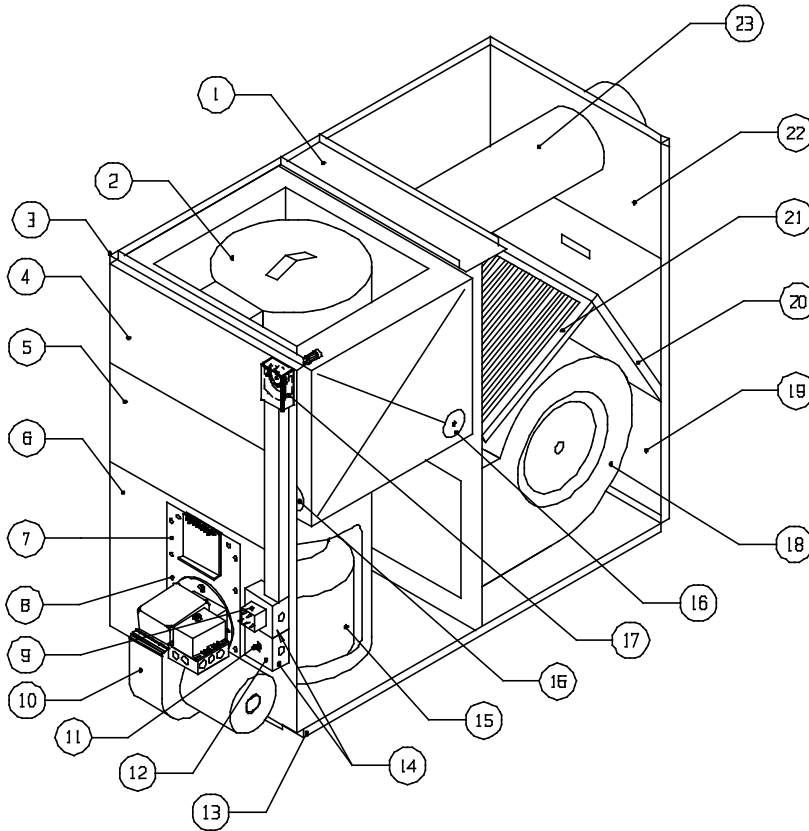


**FIG. 14D - DIMENSIONS & CONTROL LOCATIONS NL2/NV2**



d1 m12-09062006.prt

**FIG. 15-1A - NL2 ASSEMBLY**



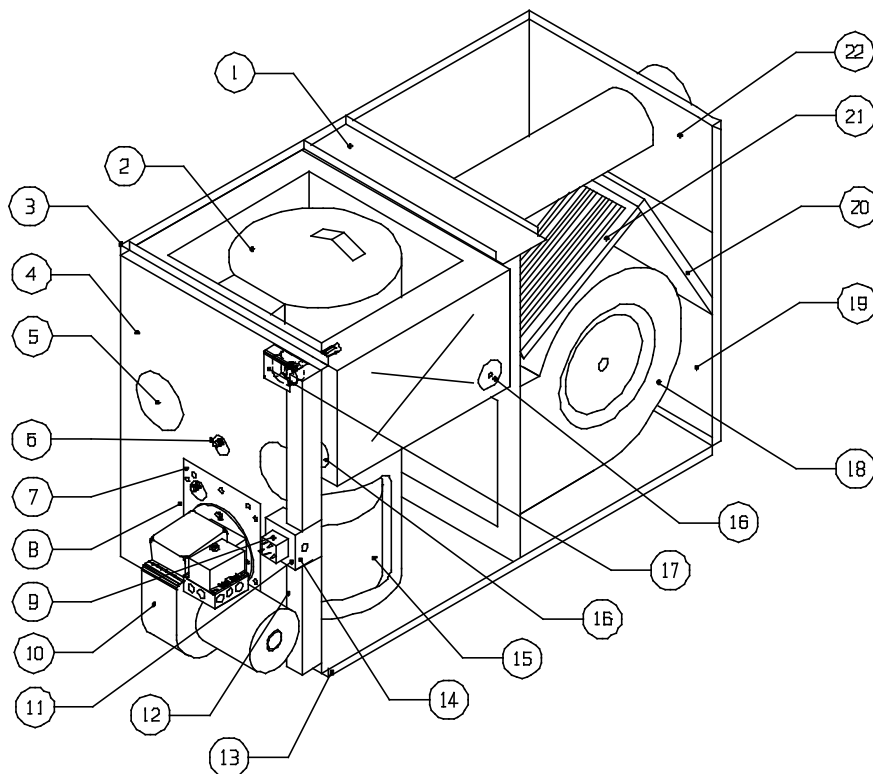
**FIG.15-1B - PARTS LIST NL2**

ITEM	PART NO.	DESCRIPTION
1	4120455G	TOP RAIL
2	4060144	HEAT EXCHANGER ASSEMBLY
3	4120451G	SIDE PANEL (L.H.)
	4120459G	SIDE PANEL (R.H.)
4	4120449G	TOP PANEL
5	4120448G	CENTER PANEL
6	4120446G	FRONT PANEL
7	4120340	BURNER PLATE
8	2080094	BURNER PLATE GASKET
	2080093	FRONT GASKET
	2080077	MOUSETRAP GASKET
9	2010041	A/C FAN CENTER - HW R8285A
10		OIL BURNER
		WIRE CHANNEL
	4100117	BURNER CABLE
11	2200256	SWITCH FOR ELECTRICAL BOX
12	2200106	BOX COVER 4 X 4 SWITCH
13		BASE PANEL
14	2200101	JUNCTION BOX 4 X 4
15	2030007	COMBUSTION CHAMBER
16	3090284	CLEANOUT COVER
	2080091	CLEANOUT COVER GASKET
	4080124	CLEANOUT COVER CONNECTOR
		PARTS BAG
	2200258	LOW SPEED SWITCH

ITEM	PART NO.	DESCRIPTION
17A	2010047	HW L6064A1094B (5") TWO SPD FAN & LIMIT - DD
17B	2010023	HW L4064B2640B (5") SINGLE SPD FAN & LIMIT - BD
		WHITE RODGERS 5D51-334 (5")
18A	2040106	G-10 AIR CIRC. BLOWER C/W 7" PULLEY (BD)
18B	2040115	G10-8 AIR CIRC. BLOWER (DD)
	2020002	1/3 HP BELT DRIVE MOTOR
	2020008	1/2 HP 4 SPD DIRECT DRIVE MOTOR
	2240002	7" PULLEY
	2240001	VARIABLE SPEED MTR PULLEY 3 1/4" X 1/2"
	2240041	FAN BELT 41" X 1/2"
	2200006-2	80" BLOWER WIRE HARNESS (4 WIRE)
	4120452G	FAN PARTITION
19	4120450G	ACCESS DOOR
20 & 21	2180004	16" X 24" FILTER
	4120453G	REAR FILTER SUPPORT
	4120454G	TOP FILTER SUPPORT
22	4120447G	SMALL PANEL
23	4080145	6" SS STACK ASSEMBLY(MAY/02)
	4110115	6" SMOKE COLLAR
	4080104	7" STACK ASSEMBLY
	4120206	7" SMOKE COLLAR
	2080043	SMOKE PIPE FLANGE GASKET
	2080059	SMOKE PIPE GASKET
	2040022	BAROMETRIC DRAFT REGULATOR

**\*\*Note – Gaskets changed to Lytherm or equivalent in 2009**

**FIG. 15-2A - NMR ASSEMBLY**



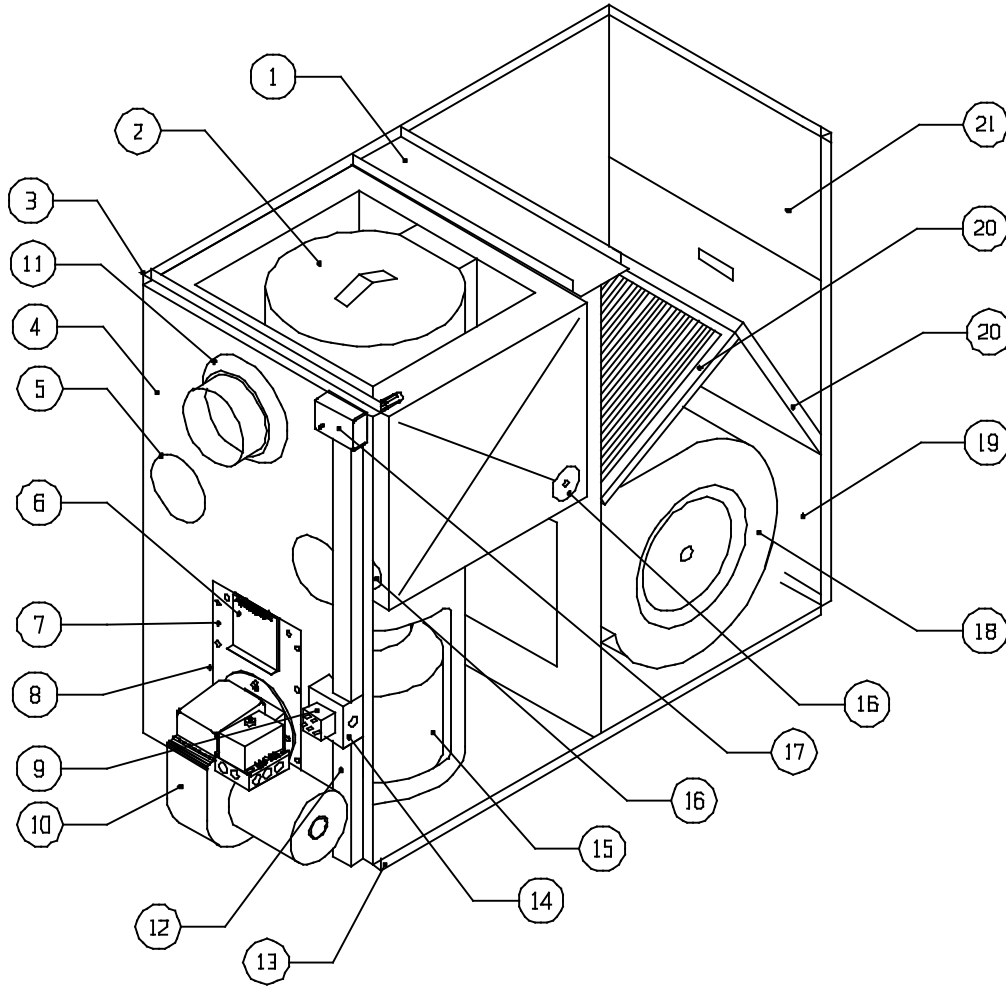
**FIG. 15-2B - PARTS LIST NMR**

ITEM	PART NO.	DESCRIPTION
1	4120333G	TOP RAIL
2	4060130	HEAT EXCHANGER
3	4120226G	SIDE PANEL (L.H.)
	4120225G	SIDE PANEL (R.H.)
4	4120111G	FRONT PANEL
5	4120486G	CLEANOUT COVER
	4080124	CLEANOUT COVER CONNECTOR
6	2080077	MOUSE TRAP GASKET
	4110524	VIEW PORT PLATE ASSLY
	3090186	VIEW PORT COVER
	2080106	VIEW PORT GASKET
7	4120471	BURNER PLATE
8	2080039	FRONT PANEL GASKET
	2080104	BURNER PLATE GASKET
9	2010041	A/C FAN CENTER -- HONEYWELL R28285A
10		OIL BURNER
11	2200103	ELECTRICAL BOX COVER
12	4120464G	WIRE CHANNEL
	4100117	18" BURNER CABLE
13		BASE PANEL
14	2200101	JUNCTION BOX 4 X 4
15	2030007	COMBUSTION CHAMBER
16	3090284	CLEANOUT COVER
	2080091	CLEANOUT COVER GASKET

ITEM	PART NO.	DESCRIPTION
17	2010025	HONEYWELL L4064B2608B (8") - BD
	2010024	HONEYWELL L6064A1086B (8") - DD
18	2040115	G10 DIRECT DRIVE BLOWER
	2040106	G10 AIR CIRC. BLOWER C/W 7" PULLEY (BD)
	2240041	FAN BELT 41" X 1/2"
	2020002	1/3 HP BELT DRIVE MOTOR
	2020008	1/2 HP 4 SPD DIRECT DRIVE MOTOR
	2240001	VARIABLE SPEED MTR PULLEY 3 1/4" X 1/2"
	2240002	7" PULLEY
	2200006-2	80" BLOWER WIRE HARNESS (4 WIRE)
	4120332G	FAN PARTITION
19	4120331G	ACCESS DOOR
	4120204	SMOKE PIPE PLATE
	2080059	SMOKE PIPE GASKET
	4110115	6" SMOKE COLLAR
20	2180001	12" x 24" FILTER
21	2180004	16" x 24" FILTER
	4120453G	FRONT FILTER SUPPORT
22	4120230G	SMALL PANEL
	2010040	5 MFD 370 V CAPACITOR
	2040022	7" BAROMETRIC DRAFT REGULATOR
	2080031	INSULATION 1/2" X 48" FOIL BACK
	4100115	PARTS BAG
	2200258	LOW SPEED SWITCH

**\*\*Note – Gaskets changed to Lytherm or equivalent in 2009**

**FIG. 15-3A - NLF ASSEMBLY**



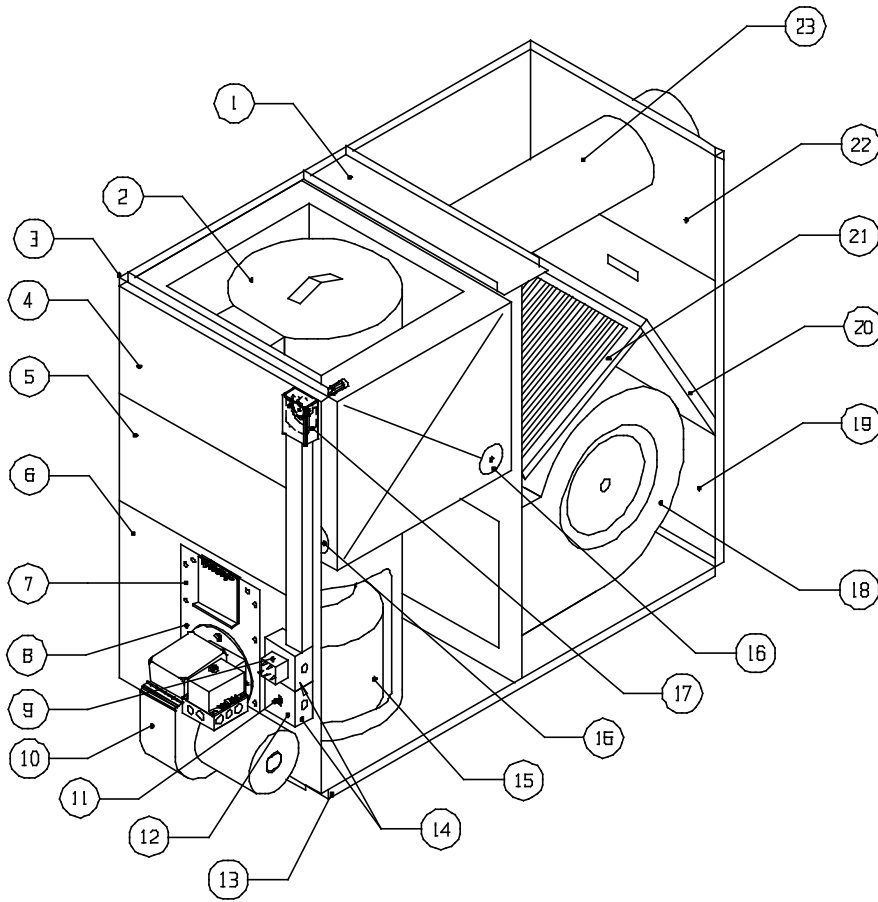
**FIG. 15-3B - PARTS LIST NLF**

ITEM	PART NO.	DESCRIPTION
1	4120455G	TOP RAIL
2	4060137	HEAT EXCHANGER
3	4120224G	SIDE PANEL (L.H.)
	4120223G	SIDE PANEL (R.H.)
4	4120114G	FRONT PANEL
5	4120486G	CLEANOUT COVER
	4080124	CLEANOUT COVER CONNECTOR
6	2080077	MOUSETRAP GASKET
7	4120340	BURNER PLATE
8	2080038	FRONT PANEL GASKET
	2080094	BURNER PLATE GASKET
9	2010041	A/C FAN CENTER - HONEYWELL R28285A
10		OIL BURNER
	4100117	18" BURNER CABLE
11	4110115	6" SMOKE COLLAR
12	4120464G	WIRE CHANNEL
	4120462G	WIRE COVER
13	4120493	BASE PANEL
	2200258	LOW SPEED SWITCH

ITEM	PART NO.	DESCRIPTION
14	2200101	JUNCTION BOX 4 X 4
	2200103	ELECTRICAL BOX COVER
15	2030007	COMBUSTION CHAMBER
16	3090284	CLEANOUT COVER
	2080091	CLEANOUT COVER GASKET
17	2010025	HONEYWELL L4064B2608B (8") - BD
	2010024	HONEYWELL L6064A1086B (8") - DD
18	2040115	G10-8 DIRECT DRIVE BLOWER
	2040111	G10 BELT DRIVE BLOWER C/W 7" PULLEY
	2020008	1/2 HP 4 SPD DIRECT DRIVE MOTOR
	2020002	1/3 HP BELT DRIVE MOTOR
	2240043	43" FAN BELT
	2200081-2	BLOWER WIRE 90"
19	4120450G	ACCESS DOOR
20	2180004	16" X 24" FILTER
	4120453G	FRONT FILTER SUPPORT
21	4120301G	SMALL PANEL
	4120485G	FAN PARTITION
	2010040	5 MFD 370 V CAPACITOR
	2040022	7" BAROMETRIC DRAFT REGULATOR

\*\*Note - Gaskets changed to Lytherm or equivalent in 2009

**FIG. 15-4A - NL3 ASSEMBLY**



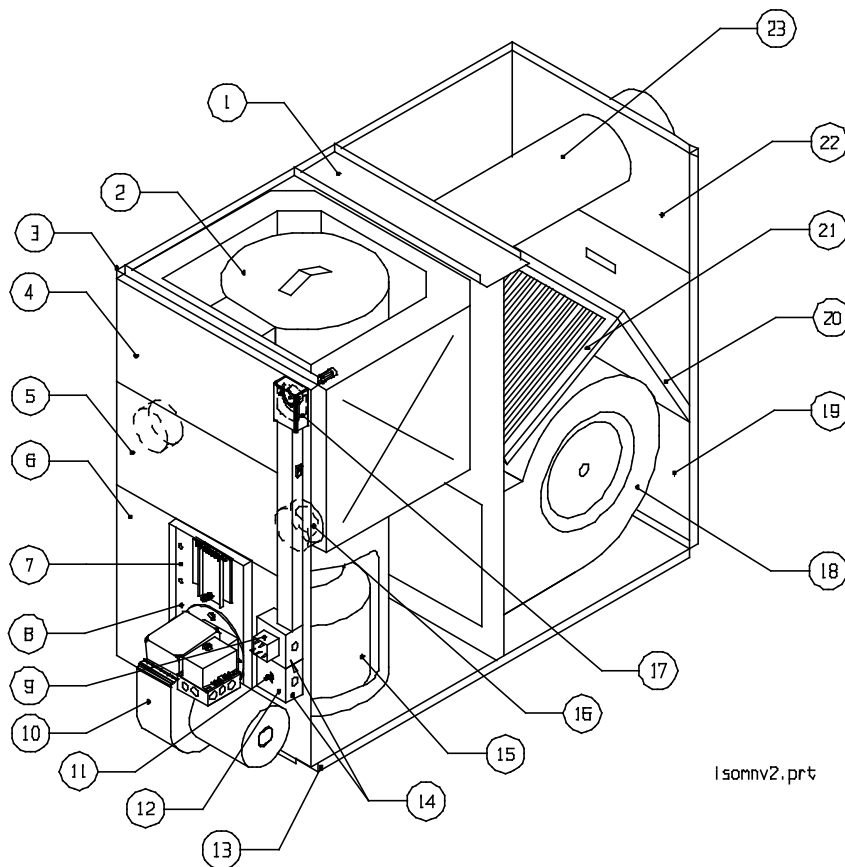
**FIG. 15-4B - PARTS LIST NL3**

ITEM	PART NO.	DESCRIPTION
1	4120422G	TOP RAIL
2	**4060149	HEAT EXCHANGER
3	4120222G	SIDE PANEL (L.H.)
	4120221G	SIDE PANEL (R.H.)
4	4120122G	TOP PANEL
5	4120302G	CENTER (CLEANOUT) PANEL
6	4120469G	LOWER FRONT PANEL
7	4120456	BURNER PLATE
8	2080015	BURNER PLATE GASKET
9	2010041	A/C FAN CENTER - HONEYWELL R28285A
		A/C FAN CENTER - PRODUCTS UNLIMITED - 57-01V08BC3E
		A/C FAN CENTER - WR - 8A94-2
10		OIL BURNER
		WIRE CHANNEL
	4100117	18" BURNER CABLE
11	2200256	SWITCH FOR ELECTRICAL BOX
12	2200106	BOX COVER 4 X 4 SWITCH
13	4120354	BASE PANEL
14	2200101	JUNCTION BOX 4 X 4
15	**2030006	COMBUSTION CHAMBER
16	3090284	CLEANOUT COVER
	2080091	CLEANOUT COVER GASKET
	4080124	CLEANOUT COVER CONNECTOR

ITEM	PART NO.	DESCRIPTION
	4120466G	ACCESS CLEANOUT COVER
17	2010023	HONEYWELL L4064B2640B (5")
		WHITE RODGERS 5051-334 (5")
18	2040103	G12 BLOWER C/W 8" PULLEY
	2020003	½ HP BELT DRIVE MOTOR
	2020020	¾ HP BELT DRIVE MOTOR
	2240002	7" PULLEY
	2240008	VARIABLE SPEED PULLEY 3 ½" X 5/8"
	2240047	47" FAN BELT
	2200081-2	BLOWER WIRE 90"
	4120310G	FAN PARTITION
19	4120324G	ACCESS DOOR
20	2180003	20" X 25" FILTER
21	2180002	16" X 25" FILTER
	4120468G	REAR FILTER SUPPORT
	4120467G	TOP FILTER SUPPORT
22	4120303G	SMALL PANEL
23	4080147	7" SS SMOKE PIPE
	4120457	7" SMOKE COLLAR
	2080043	SMOKE PIPE FLANGE GASKET
	2080057	SMOKE PIPE GASKET
	4080125	STACK BAFFLE
	2040022	7" BAROMETRIC DRAFT REGULATOR
	4100115	PARTS BAG

\*\*NL3 replacement heat exchangers or corbel chambers for units constructed prior to September 29/1994 must have the new burner plate and burner plate gasket listed above

FIG. 15-5A – NV2/NV2-5 ASSEMBLY



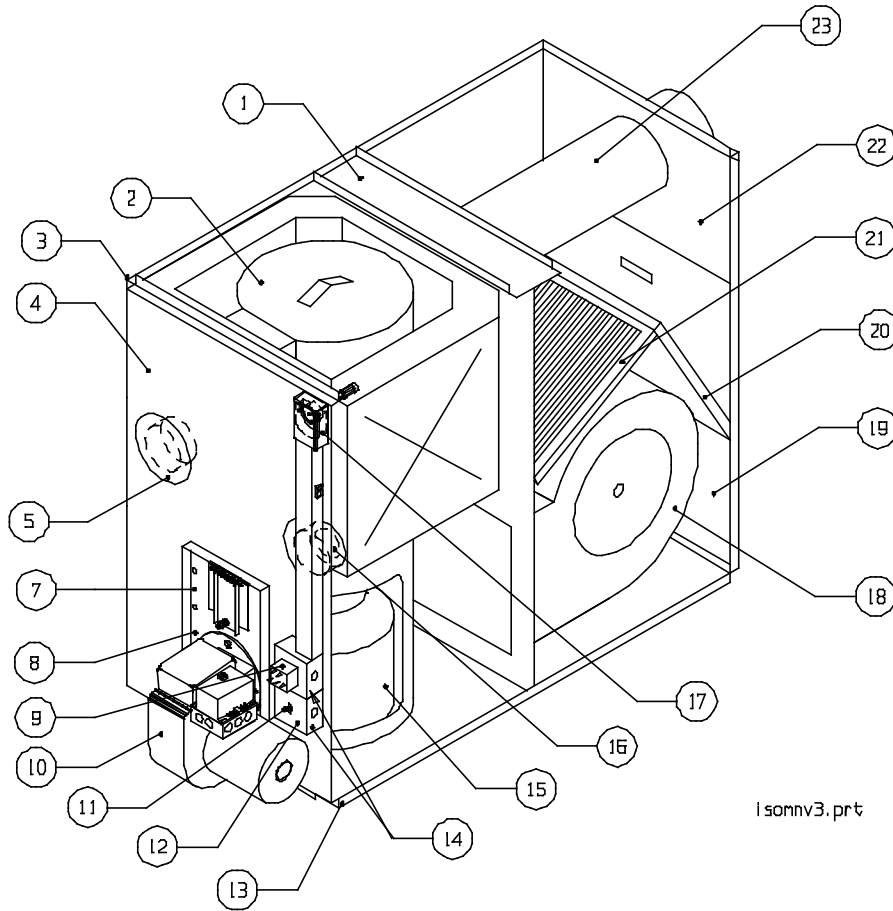
Isomnv2.prt

FIG. 15-5B - PARTS LIST NV2/NV2-5

ITEM	PART NO.	DESCRIPTION
1	4120455G	TOP RAIL
2	4060322	HEAT EXCHANGER ASSEMBLY
3	4120338	SIDE PANEL (L.H.)
	4120337	SIDE PANEL (R.H.)
4	4120449G	TOP PANEL
5	4120123	CENTER PANEL
6	4120446G	FRONT PANEL
7	4120340	BURNER PLATE
8	2080094	BURNER PLATE GASKET
	2080093	FRONT GASKET
9	2010041	A/C FAN CENTER - HW R8285A
	2010059	A/C FAN CENTER - HW R8239B
		A/C FAN CENTER - WR - 8A94-2
10		OIL BURNER
		WIRE CHANNEL
	4100117	BURNER CABLE
11	2200256	SWITCH FOR ELECTRICAL BOX
12	2200106	BOX COVER 4 X 4 SWITCH
13		BASE PANEL
14	2200101	JUNCTION BOX 4 X 4
15	2030007	COMBUSTION CHAMBER
16	3090284	CLEANOUT COVER
	2080029	CLEANOUT COVER GASKET
	4080124	CLEANOUT COVER CONNECTOR
		PARTS BAG
	2200258	LOW SPEED SWITCH

ITEM	PART NO.	DESCRIPTION
17A	2010047	HW L6064A1094B (5") TWO SPD FAN & LIMIT - DD
17B	2010023	HW L4064B2640B (5") SINGLE SPD F/L - BD & 5-Ton
		WHITE RODGERS 5D51-334 (5")
18A	2040106	G-10 AIR CIRC. BLOWER C/W 7" PULLEY (BD)
18B	2040115	G10-8 AIR CIRC. BLOWER (DD)
18C	2040144	G12-10 AIR CIRC. BLOWER (DD)
	2020002	1/3 HP BELT DRIVE MOTOR
	2020008	1/2 HP 4 SPD DIRECT DRIVE MOTOR
	2020022	3/4 HP DD 5 SPD DIRECT DRIVE MOTOR
	2240002	7" PULLEY
	2240001	VARIABLE SPEED MTR PULLEY 3 1/4" X 1/2"
	2240041	FAN BELT 41" X 1/2"
	2200006-2	80" BLOWER WIRE HARNESS (4 WIRE)
	4120336	FAN PARTITION
19	4120450G	ACCESS DOOR
20 & 21	2180004	16" X 24" FILTER
	4120453G	REAR FILTER SUPPORT
	4120454G	TOP FILTER SUPPORT
22	4120447G	SMALL PANEL
23	4080145	6" SS STACK ASSEMBLY(MAY/02)
	4110115	6" SMOKE COLLAR
	4080104	7" STACK ASSEMBLY
	4120206	7" SMOKE COLLAR
	2080043	SMOKE PIPE FLANGE GASKET
	2080059	SMOKE PIPE GASKET
	2040022	BAROMETRIC DRAFT REGULATOR

**FIG. 15-6A – NV3 ASSEMBLY**



lsonnv3.prt

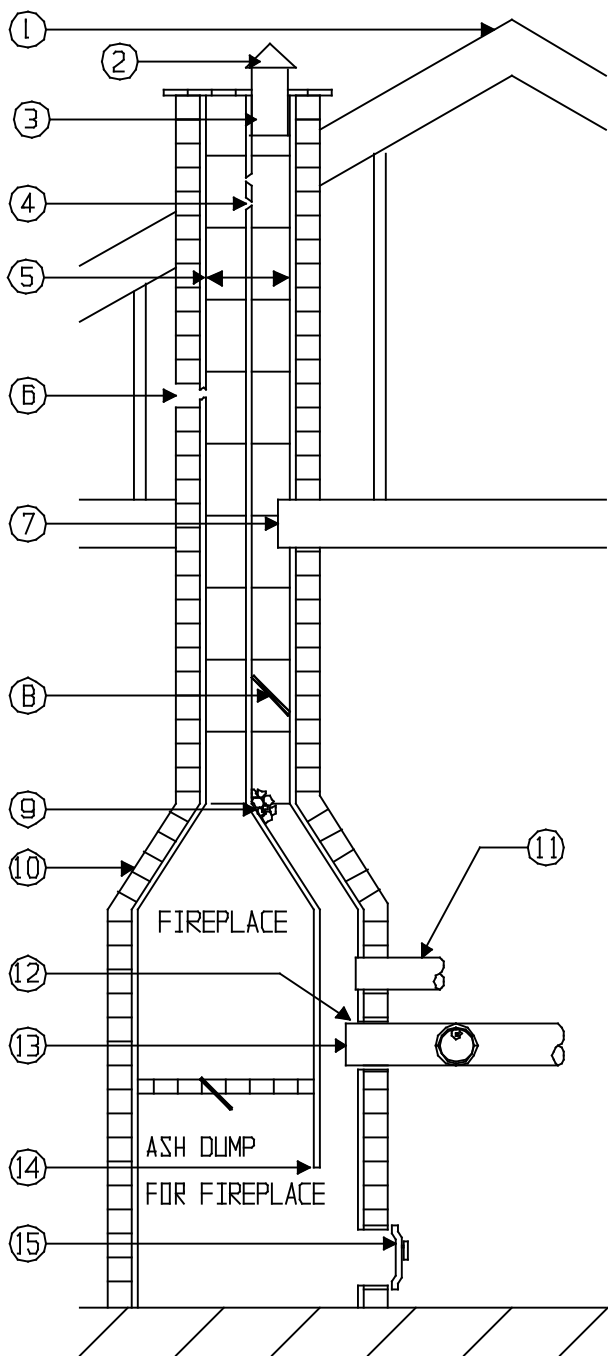
**FIG. 15-6B - PARTS LIST NV3**

ITEM	PART NO.	DESCRIPTION
1	4120422G	TOP RAIL
2	4060405	HEAT EXCHANGER
3	4120350	SIDE PANEL (L.H.)
	4120351	SIDE PANEL (R.H.)
4	4120349	FRONT PANEL
5	4120466G	CLEANOUT PANEL
7	4120348	BURNER PLATE
8	2080081	BURNER PLATE GASKET
	2080082	FRONT PANEL GASKET
9	2010041	A/C FAN CENTER – HONEYWELL R28285A
		A/C FAN CENTER - PRODUCTS UNLIMITED - 57-01V08BC3E
		A/C FAN CENTER - WR - 8A94-2
10		OIL BURNER
		WIRE CHANNEL
	4100117	18" BURNER CABLE
11	2200256	SWITCH FOR ELECTRICAL BOX
12	2200106	BOX COVER 4 X 4 SWITCH
13		BASE PANEL
14	2200101	JUNCTION BOX 4 X 4
15	2030006	COMBUSTION CHAMBER
16	3090284	CLEANOUT COVER
	2080029	CLEANOUT COVER GASKET
	4080124	CLEANOUT COVER CONNECTOR
	2040022	7" BAROMETRIC DRAFT REGULATOR
	4100115	PARTS BAG

ITEM	PART NO.	DESCRIPTION
17A	2010047	HW L6064A1094B (5") TWO SPD FAN & LIMIT - DD
17B	2010023	HONEYWELL L4064B2640B (5")
		WHITE RODGERS 5051-334 (5")
18	2040103	G12 BD BLOWER C/W 8" PULLEY
	2040117	G12-9 DD BLOWER
	2020003	½ HP BELT DRIVE MOTOR
	2020020	¾ HP BELT DRIVE MOTOR
	2020022	¾ HP DIRECT DRIVE MOTOR
	2240002	7" PULLEY
	2240008	VARIABLE SPEED PULLEY 3 ½" X 5/8"
	2240047	47" FAN BELT
	2200081-2	BLOWER WIRE 90"
	4120310G	FAN PARTITION
19	4120324G	ACCESS DOOR
20	2180003	20" X 25" FILTER
21	2180002	16" X 25" FILTER
	4120468G	REAR FILTER SUPPORT
	4120467G	TOP FILTER SUPPORT
22	4120303G	SMALL PANEL
23	4080147	7" SS SMOKE PIPE
	4120457	7" SMOKE COLLAR
	2080043	SMOKE PIPE FLANGE GASKET
	2080057	SMOKE PIPE GASKET
	4080125	STACK BAFFLE



**FIG. 16 - COMMON CHIMNEY DRAFT PROBLEMS**



chnprgreng16062006.prt

Cause		Correction
1	Roof peak buildings or trees higher than chimney	Extend chimney height
2	Downrafts	Install chimney cap
3	Coping restricts opening	Enlarge to chimney inside dimensions
4	Break in lining	Repair making sure connections are tight
5	Sized incorrectly	Size for appliance specifications
6	Outside Air Leak	Repair and seal all joints
7	Joist protrudes into chimney	Remove
8	Obstruction	Dislodge and remove
9	Soot accumulation in offset	Remove
10	Offset too short	Straighten or lengthen
11	More than one appliance connected to the same chimney flue	Use a "Y" for common vent connector. For two flue connectors, install smaller appliance on top with capped end and opening on top.
12	Loose seated pipe in flue opening	Seal air gaps
13	Smoke pipe extends into chimney	Make end flush with inside of chimney
14	Opening between flues	Extend flue partition to floor level
15	Loose cleanout door	Close tightly and seal all leaks
16	Open fireplace	Seal opening
17	New chimney	Allow 2 to 4 weeks for curing
18	Too little draft	Adjust draft regulator (close)
19	Back up of flue gas from draft diverter	Clean chimney and thoroughly inspect
20	Too much draft	Adjust draft regulator (open)
21	Too many appliances on the same flue	Remove appliances
22	Too much draft with draft regulator fully open	Install larger or multiple draft regulators
23	Smoke pipe extends to far into elbow	Pull the smoke pipe back
24	Smoke pipe too close to chimney base	Raise smoke pipe or extend inside. Cut on an angle with the opening facing up and clean regularly
25	Widely fluctuating draft and downrafts	Try a different type of chimney cap
26	Unused flue or vent connection	Remove and seal the opening
27	House depressurization	Provide additional combustion air
28	Flue pipe too long or too many elbows	Minimize flue pipe total equivalent length

chnprbengt16062006.xls

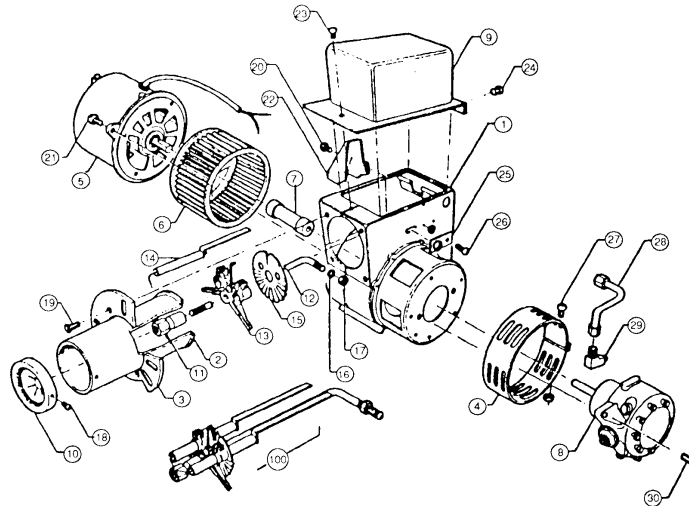
**FIG. 17A - TROUBLESHOOTING CHART**

<b>PROBLEM</b>	<b>CAUSE</b>	<b>CORRECTION</b>
Burner Motor Fails to Start	Thermostat	Check for Broken Wires
		Tighten Connections
		Clean Contacts
		Replace Thermostat
	Burner Motor Overload Tripped	Press Rest Button
Ceased Pump	Repair or Replace	
Faulty Primary Relay	Repair or Replace	
Burner Start--No Flame	Oil Supply	Check Oil Supply
	Air Leak in Oil Supply Line	Tighten Fittings or Replace Line
	Oil Line Plugged or Kinked	Clean or Repair
	Oil Filter Clogged	Replace or Clean
	Loss of Prime	Eliminate Teed Oil Lines
	Electrode Setting	Adjust Electrodes
	Loose or Dirty Nozzle	Replace Nozzle
	Ignition Transformer	Replace Transformer
	Burner Motor Overload Trips	Press Rest Button
	Ceased Pump	Repair or Replace
Faulty Primary Relay	Repair or Replace	
Burner Locks out on Safety	Cad Cell	Clean or Replace
	Oil Line Restricted	Clear Restriction
	Plugged Fuel Pump	Clean Strainer
	Loss of Prime	Eliminate Teed Oil Lines
	Cold Oil	Change to #1 Oil
		Convert to One Line System
Poor Combustion	Adjust Air Settings Ensure Draft is Adequate	
Burner Ignition Delayed	Air Leak in Oil Supply Line	Tighten Fittings or Replace Line
	Loose or Dirty Nozzle	Replace Nozzle
	Faulty Oil Pump	Repair or Replace Pump
	Oil Supply Line	Ensure Properly Designed
	Loss of Prime	Eliminate Teed Oil Lines
	Electrode Setting	Adjust Electrodes
	Cracked Electrodes	Replace Electrodes
	Wrong Nozzle	Use Specified Nozzle
	Low Oil Pressure	Adjust to Correct Setting
	Excess Air	Adjust Air Setting
Faulty Transformer	Replace Transformer	
Fumes & Odors From Burner	Insufficient Combustion Air	Provide Combustion Air
	Inadequate Flue Draft	Provide Specified Draft
	Pump Seal Leaking	Repair Pump
	Loss of Prime	Eliminate Teed Oil Lines
	Nozzle Assembly Adjustment	Ensure Setting is Correct
	Burner Adjustment	Check Using Instruments
	Blast Tube Burned Off	Check Blast Tube
	End Cone Wrong or Burned Off	Check End Cone
	Incorrect Insertion	Measure Insertion Depth
	Dirty Burner Fan	Clean Blades
	Damaged Chamber	Check Chamber
	Clogged Flue Passages	Clean Flue Passages
Nozzle After Drip	Check Fuel Delivery System	
Unspecified Nozzle	Replace Nozzle	

**FIG 17B - TROUBLESHOOTING CHART – continued**

<b>PROBLEM</b>	<b>CAUSE</b>	<b>CORRECTION</b>
Not Enough Heat	Firing Rate Too Low	Use Higher Input Nozzle
	Dirty Heat Exchanger	Clean Heat Exchanger
	Poor Combustion	Adjust Using Instruments
	Undersized Capacity	Size Based on Heat Loss
	Distribution System	Ensure Proper Design
	Faulty Thermostat or Location	Repair, Replace, or Relocate
Too Much Heat	Defective Primary Control	Repair or Replace
	Faulty Thermostat or Location	Repair, Replace, or Relocate
	Faulty Oil Pump	Check for Proper Pressure
	Firing Rate Too High	Reduce Nozzle Size
	Oversized Capacity	Size Based on Heat Loss
	Distribution System	Proper Duct Design
Excessive Oil Consumption	Poor Combustion	Adjust Using Instruments
	Excess Air	Adjust Air Setting
	Inadequate Flue Draft	Provide Specified Draft
	Insufficient Combustion Air	Provide Combustion Air
	Oil Supply	Check Oil Supply
	Electrode Setting	Adjust Electrodes
	Wrong Nozzle	Use Specified Nozzle
	Fuel System Leaking	Check Fuel System
	Faulty Oil Pump	Repair or Replace Pump
Short Cycle	Over-Firing	Use Specified Nozzle Size
	Tripping High Limit	Replace Dirty Filters
		Increase Blower Speed
		Increase Undersized R/A Ducts
		Clear Blocked Return Registers
		Increase Undersized S/A Ducts
		Clear Blocked Supply Grills
		Replace Faulty Blower Motor
	Clean Clogged Blower Wheel	
	Replace Broken Blower Belt	
	Faulty Thermostat or Location	Repair, Replace, or Relocate
Heat Anticipator Set Too Low	Adjust Heat Anticipator	
Defective Primary Relay	Repair or Replace Relay	
Noise	Burner Pump Whine	Eliminate Suction Line Air Leak
	Duct Expansion	Stiffen Plenum & Ducts
	Plenum Amplifies Noise	Install Plenum Apron
Burner Air Tube Burn-Off	Blocked Flue Passages	Clean Boiler
	Unspecified Burner	Replace Burner
	Unspecified Nozzle	Install Correct Nozzle
	Incorrect Head	Install Correct Head
	Wrong/Misaligned Static Plate	Install Correct Plate or Align
	Chimney Down Drafting	Install Chimney Cap
	Poor Over-Fire Draft	Increase Draft at Breech
		Correct Chimney Problems
	Over-Firing	Use Specified Nozzle
Use Specified Pressure		
Incorrect Insertion	Use Correct Air Tube Assembly	
	Adjust Flange	
Frequent Sooting	Reduced Draft	Add Combustion Air
	Delayed Ignition	Adjust Burner Settings
	Loss of Prime	Eliminate Teed Oil Lines
	Unspecified Burner	Replace Burner
	Unspecified Nozzle	Install Correct Nozzle
	Incorrect Head	Install Correct Head
Premature Corrosion	Temperature Rise Too Low	Reduce Motor Speed
		Use Higher Specified Nozzle

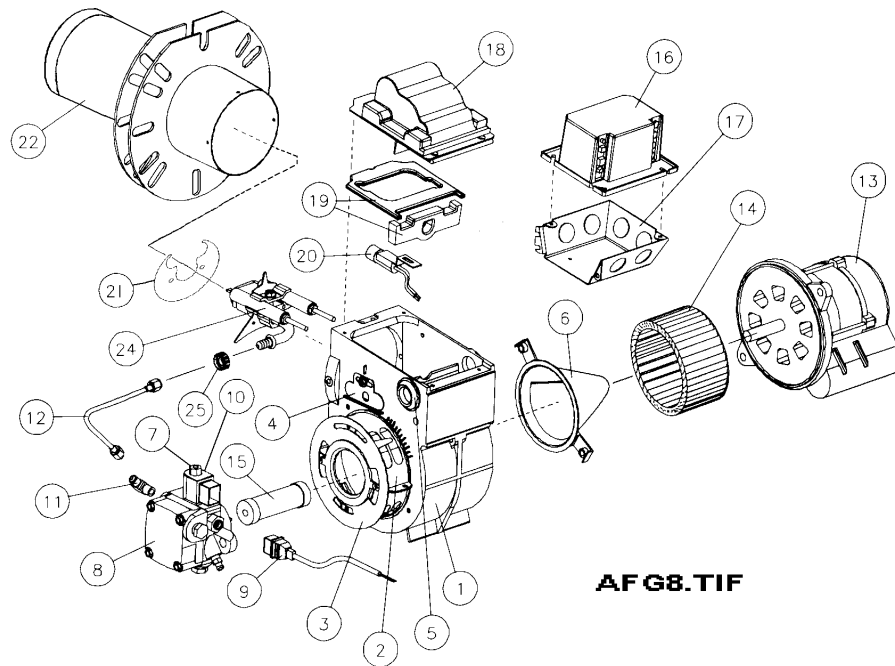
**FIG. 18-1A - AERO BURNER EXPLODED ASSEMBLY**



**FIG. 18-1B - AERO BURNER PARTS LIST**

ITEM NO.	PART NUMBER		DESCRIPTION
	AERO	NEWMAC	
1	65000		F Housing
2		2090003	Blast Tube 7" (NL2,NV2)
		2090006	Blast Tube 8" (NL3,NV3,NLF,NMR)
3	65004		Mounting Flange Standard
4	65518		Air Band Assembly 3 Hole
5		2020011	Motor, 1/7 HP 3450 RPM
6			Motor, 1/6 HP 3450 RPM
			Fan, 508-229
7	2433804813		Flexible Coupling Mini Pump
	2433833375		Flexible Coupling J Pump
8		2060004	A2VA-7116 Single Stage 3450 RPM
			Fuel Pump J2-CB-100 Single Stage 3450 RPM
			H3-CB-100 Two Stage 3450 RPM
			B2Va-8216 Two Stage 3450 RPM
9		2090066	Transformer Alanson 2275-456
		2090002	Transformer Alanson Iron Core 2721-456
			France 2LAY-567T
			Robertshaw S10-400
10		2110005	End Cone AFC-2X (NL2,NV2,NLF,NMR)
		2110003	End Cone AFC-3 (NL3,NV3)
11	30038		Nozzle Adapter
12			Oil Pipe, Aluminum (specify blast tube length)
13	65019		Electrode Holder
14		5300011	Electrode (with porcelain) (1pair)
14A			Bus Bars (specify length)
15			HF-US Turbo Static Disc 3 3/8"
16	30037		Jam Hex Nut
17	65018		Knurled Lock Nut
100 (11 to 17)		2090026	Electrode Assembly (NL2)
		2090027	Electrode Assembly (NL3,NLF,NMR)
18	30053		HF-US End Cone Screws
19			Blast Tube Screw (specify length)
20	65062		Raceway
21	30054		Motor Screws
22	30095		Raceway Screw
23	30063		Transformer Lock-down Screw
24	30067		Transformer Hinge Screw
25	65017		Slide Plate
26	65012		Slide Plate Pop Rivet
27	30054		Air Band Locking Screw
28	65524		Oil Line Assembly
30	30054		Fuel Pump Screws
		2100130	Nozzle, Delavan 0.65 X 70°A (NL2,NV2,NLF,NMR)
		2100131	Nozzle, Delavan 0.75 X 70°A (NL2,NV2,NLF,NMR)
		2100128	Nozzle, Delavan 0.85 X 70°A (NL2,NV2,NLF,NMR)
		2100132	Nozzle, Delavan 1.00 X 70°A (NL2,NV2,NLF,NMR,NL3,NV3)
		2100129	Nozzle, Delavan 1.25 X 70°A (NL3,NV3)
		2100133	Nozzle, Delavan 1.35 X 70°A (NL3,NV3)
		2100134	Nozzle, Delavan 1.50 X 70°A (NL3,NV3)

**FIG. 18-2A - BECKETT BURNER EXPLODED ASSEMBLY**

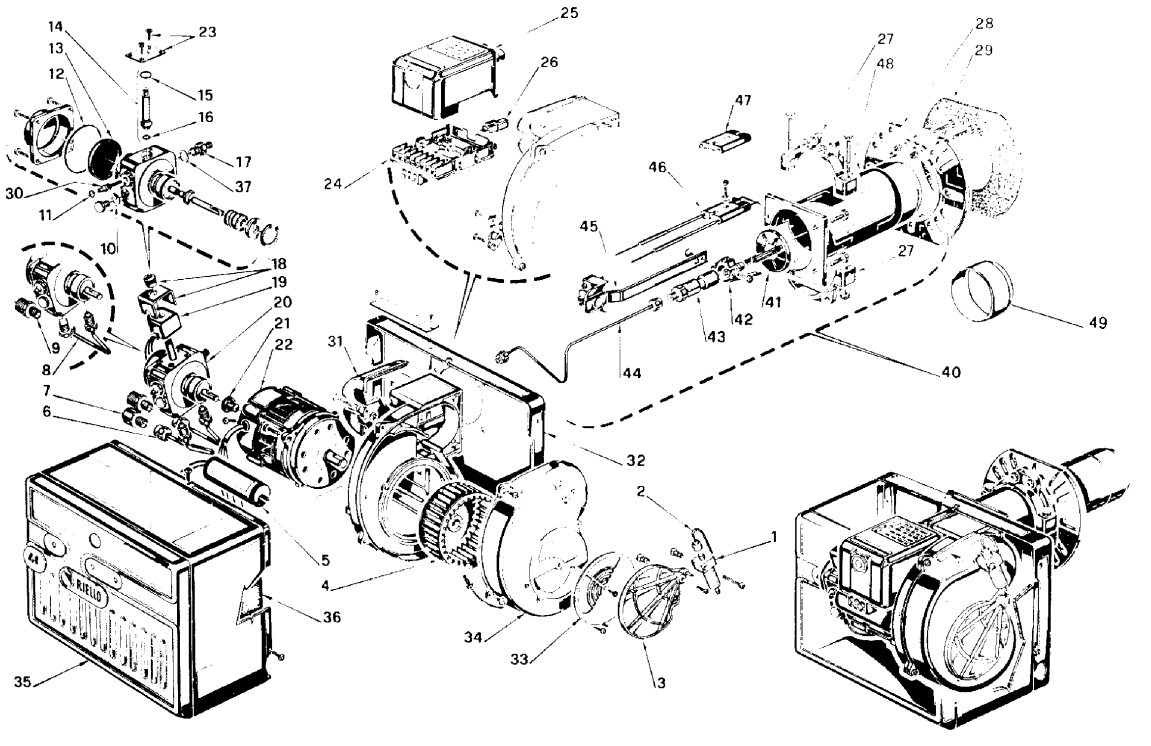


**AFG8.TIF**

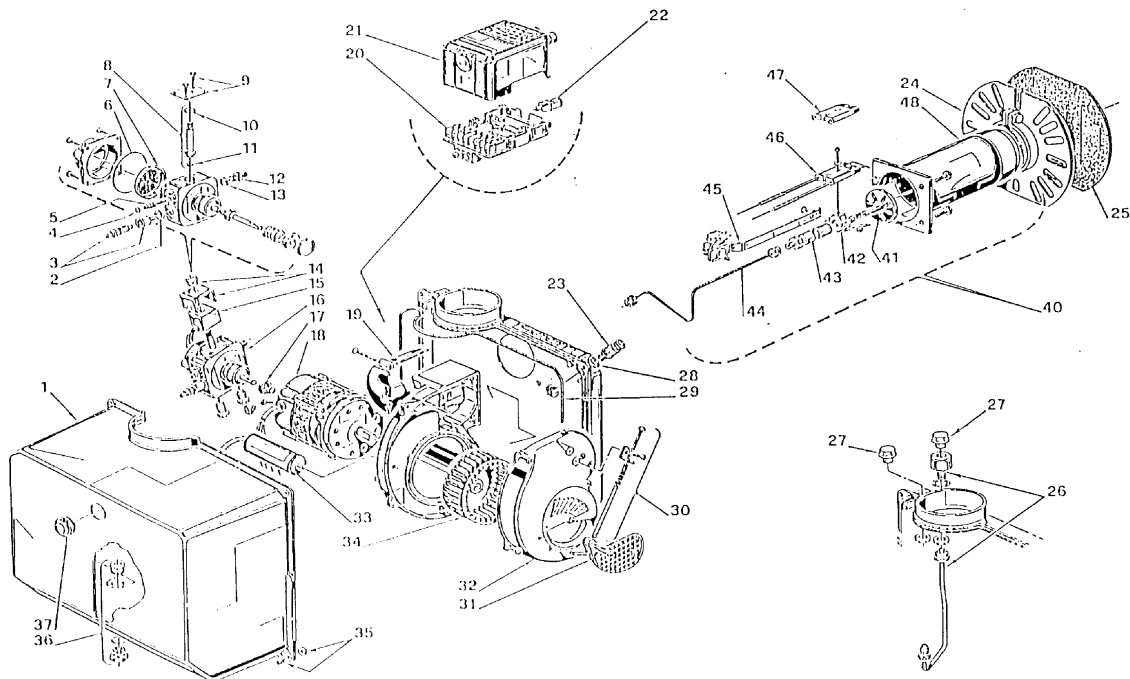
**FIG. 18-2B - BECKETT BURNER PARTS LIST**

ITEM NO.	PART NUMBER		NM501	NM502	NM503	NM505	NM506	DESCRIPTION
	BECKETT	NEWMAC						
1	5877	2090024	X	X	X	X	X	Burner Housing Assembly
2	3709		X	X	X	X	X	Air Shutter
3	3492		X	X	X	X	X	Air Band
4	3493		X	X	X	X	X	Escutcheon Plate
8	21844U	2060012	X	X	X	X	X	Pump Clean Cut A2EA - 6520
	51843U		X	X	X	X	X	Strainer & Gasket
10	21755U	2090065	X	X	X	X	X	Valve Coil (Suntec Part No. 3713824)
7	21877U	2090072	X	X	X	X	X	Valve Stem
	51573	2090058						Suntec Pump c/w Solenoid Valve
	51843U							Strainer & Gasket
	21755U							Valve Coil (Suntec Part No. 3713824)
								Valve Stem (Includes 2 O Rings) (Suntec Part No. 3773578)
								Solenoid Valve Repair Kit (Suntec Part No. 991375)
9	21807		X	X	X	X	X	Valve cordset
11	2256							Pump Nozzle Port Fitting
12	5394							Connector Tube Assembly
13	21805U	2020012	X	X	X	X	X	PSC Drive Motor, 3450 RPM
14	2999U	2090056	X	X	X	X	X	Blower Wheel
16A	7456U	2090069	X	X	X			Primary Relay, Honeywell R7184B
16B	7457U	2090067				X	X	Primary Relay, Honeywell R7184P
17	5770		X	X	X	X	X	Junction Box Kit
18	51771U	2090064	X	X	X	X	X	Electronic Ignitor (14,000 Volt)
20	7006U	2010006	X	X	X	X	X	Cad Cell C554A1455B Honeywell
21	3384		X	X	X	X	X	3-3/8U Static Plate
22A	5153632BK	2090038	X			X		Blast Tube c/w Welded Flange AFG (6 7/8")
22B	5153633BK	2090039		X	X		X	Blast Tube c/w Welded Flange AFG (7 7/8")
		2110007	X	X		X		Endcone, F4
		2110009			X		X	Endcone, F6
24		2090022	X	X	X	X	X	Electrode Assembly 8"
	31517	2110015	X	X	X	X	X	Ceramic Heat Shield
		2110016	X	X	X	X	X	Ceramic Heat Shield Holder
		2080051	X	X	X	X	X	Flange Gasket
	51770	2090061				X	X	Field Controls AirBoot
	5880	2090044	X	X	X	X	X	Low Firing Rate Baffle
	5941		X	X	X	X	X	Adjusting Plate Assy
		2100130	X	X		X		Nozzle, Delavan 0.65 X 70°A
		2100131	X	X		X		Nozzle, Delavan 0.75 X 70°A
		2100128	X	X		X		Nozzle, Delavan 0.85 X 70°A
		2100132	X	X	X	X	X	Nozzle, Delavan 1.00 X 70°A
		2100129			X		X	Nozzle, Delavan 1.25 X 70°A
		2100133			X		X	Nozzle, Delavan 1.35 X 70°A
		2100134			X		X	Nozzle, Delavan 1.50 X 70°A

**FIG. 18-3A RIELLO F3 & F5 EXPLODED ASSEMBLY**



**FIG. 18-3B - RIELLO BF3 & BF5 EXPLODED ASSEMBLY**

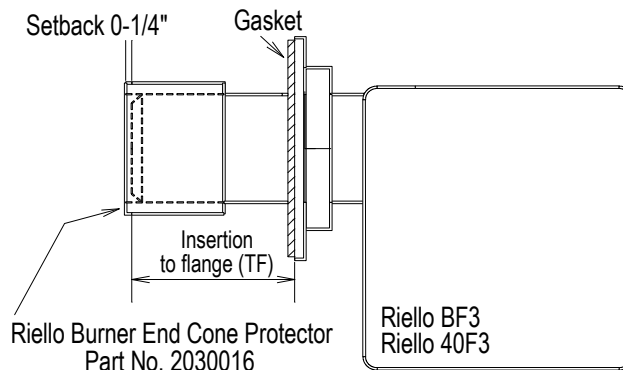


**Riello Burner End Cone Protector not shown. See FIG.18-3D for its location.**

**FIG. 18-3C - RIELLO BURNER PARTS LIST**

ITEM		PART NUMBER		BURNER MODEL				DESCRIPTION
F3 & F5	BF3 & BF5	RIELLO	NEWMAC	F3	F5	BF3	BF5	
1		3006911	2090055	X	X			Hydraulic jack
4	34	3005708		X	X	X	X	Fan
5	33	3005844	2090041	X	X	X	X	Capacitor 12.5 Uf
12	6	C7010002	2090043	X	X	X	X	O-ring - pump cover
19	15	3002279		X	X	X	X	Coil
20	16	3007802	2060007	X	X	X	X	Pump
22	18	3005843		X	X	X	X	Motor
25	21	3001157	2010048	X	X	X	X	Primary control 530 SE/C
26	22	3002280	2010045	X	X	X	X	Photo cell
28	24	3005855		X	X	X	X	Universal mounting flange
29	25	3005856	2080058	X	X	X	X	Mounting gasket
33		3007204		X	X			Manual Air Shutter
	1	3008019				X		Burner cover
	1	3008023					X	Burner Cover
40	40	3948873		X		X		Short combustion head - 6"
	40	3948973			X		X	Short combustion head - 6"
		3948874		X		X		Long combustion head - 10"
		3948973			X		X	Long combustion head - 10"
46	46	3006330		X		X		Electrode assembly - short
	46	3006329			X		X	Electrode assembly - short
		3005870		X		X		Electrode assembly - long
		3005880			X		X	Electrode assembly - long
47	47	3005869		X	X	X	X	Electrode porcelain
48	48	3007592		X		X		End cone assembly - short
	48	3007594			X		X	End cone assembly - short
		3007593		X		X		End cone assembly - long
		3007595			X		X	End cone assembly - long
	3	3007568				X	X	Bleeder
	27	3007901				X	X	Plug
	30	3000681				X	X	Manual air damper regulator
	31	3008021				X	X	Air damper
	35	3007707				X	X	Cover screw and washer
	37	3007627				X	X	Plug-cover opening-burner reset
		C7001025	2110172			X		Two line conversion kit
		C7001026	2110173				X	Two line conversion kit
			2010034	X	X			24V Relay, Switching (for Riello)

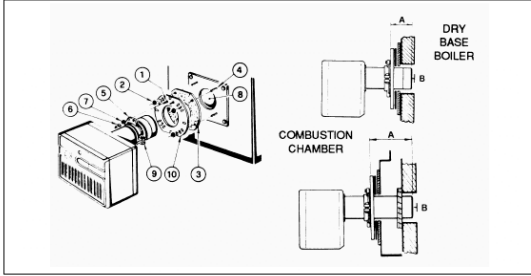
**FIG. 18-3D – RIELLO SLEEVE POSITION**



# RIELLO BURNER INSTRUCTIONS

## Universal Mounting Flange

- A) Insert the two BOLTS (1) into the UNIVERSAL MOUNTING FLANGE (10) from the flat side, ensuring the bolt heads are flush with the flat surface. Secure in place using two special CHROME NUTS (2) provided.



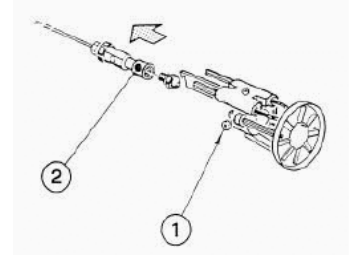
- B) Position the MOUNTING GASKET (3) between the flat surface of the UNIVERSAL MOUNTING FLANGE (10) and the appliance. Line up the holes in the UNIVERSAL MOUNTING FLANGE with the STUDS (4) on the appliance mounting plate and securely bolt the UNIVERSAL MOUNTING FLANGE to the plate.
- C) Secure the two semi-flanges of the ADJUSTABLE COLLAR (9) to the AIR TUBE using the two long BOLTS (6). Be sure that the ADJUSTABLE COLLAR (9) is properly positioned so the outside edge of the END CONE will be at least ¼ inch (6.5mm) back from the inside wall of the refractory of the combustion chamber (see dimension B above). The measured length (A) is to include MOUNTING GASKET and FLANGE, if used.
- D) The burner may now be attached to the heating unit by inseting the AIR TUBE through the BURNER ACCESS HOLE (8) and into the appliance, making sure the BOLTS (1) line up with the two HOLES (5) in the ADJUSTABLE COLLAR (9). Secure the burner in place using two NUTS (7).

A visual verification of the air tube insertion into the combustion chamber of the heating unit is suggested. Dimension B should be at least ¼" (see drawing).

**NOTE:** A suggested method for creating mounting bolt holes in the mounting gasket: Hold the gasket against the appliance mounting bolts using the mounting flange for proper positioning. Lightly tap the flange with a hammer to form the holes.

## Nozzle Placement

- A) Determine the proper firing rate for the boiler or furnace units, considering the specific application, and then use the Burner Setup charts on page 15 to select the proper nozzle and pump pressure to obtain the required input from the burner.
- B) Remove the NOZZLE ADAPTER (2) from the DRAWER ASSEMBLY by loosening the SCREW (1).
- C) Insert the proper NOZZLE into the NOZZLE ADAPTER and tighten securely (Do not over tighten).
- D) Replace adapter, with nozzle installed, into drawer assembly and secure with screw (1).



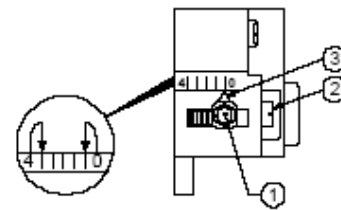
## Turbulator Setting

- A) Loosen NUT (1), and then turn SCREW (2) until the INDEX MARKER (3) is aligned with the correct index number as per the Burner Setup charts, or OEM specifications given with the appliance.
- B) Retighten the RETAINING NUT (1).

**NOTE: OEM specifications take priority over retrofit specifications shown (refer to General Instructions-Page 1).**

**MODEL F3 NOTE:** Zero and four are scale indicators only. From left to right the first line is 4 and the last line 0.

**MODEL F5:** Same as above, except, scale indicators are 0 and 3.

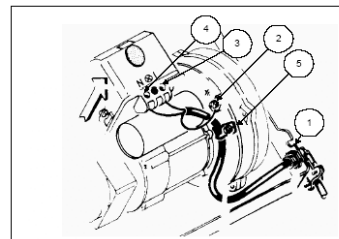


## Electrical Connections

It is advisable to leave the control box off the sub-base while completing the electrical connection to the burner.

- 1) Wire access hole (Use BX electrical connector)
- 2) Earth ground conductor terminal (Green wire)
- 3) Hot conductor terminal (Black wire)
- 4) Neutral conductor terminal (White wire)
- 5) Strain relief clamp

**WARNING: The hot (black) wire must be connected to the L terminal and the neutral (white) wire must be connected to the N terminal or the primary safety control will be damaged.**



The burner may be controlled using either a DIRECT LINE VOLTAGE control circuit (120V AC 60 cycle) OR a LOW VOLTAGE control switching relay.



Using the appropriate diagram below, make electrical connections to burner. All wiring must be done in accordance with existing electrical codes, both national and local.

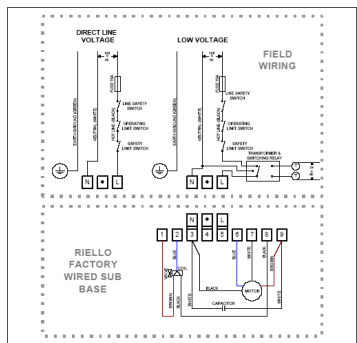
When all electrical connections have been made, the control box may be put back in place on the sub-base.

**WARNING: DO NOT activate burner until proper oil line connections have been made, or failure of the pump shaft seal may occur.**

**Application Field Wiring**

**REMOTE SENSING OF SAFETY LOCKOUT:** The SAFETY SWITCH in the 530SE CONTROL BOX is equipped with a contact allowing remote sensing of burner lockout. The electrical connection is made at terminal 4 (●) on the SUB-BASE. Should lockout occur the 530SE CONTROL BOX will supply a power source of 120Vac to the connection terminal. The maximum allowable current draw on this terminal (4) is 1 Amp.

**WARNING: If a neutral or ground lead is attached to this terminal, the CONTROL BOX on the burner will be damaged should lockout occur.**



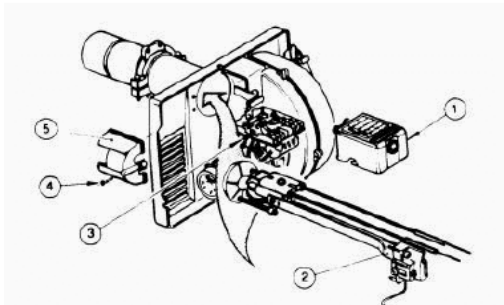
**Insertion/Removal of Drawer Assembly**

Removal:

- A) Loosen off oil delivery tube nut from pump.
- B) Loosen SCREW (3), and then unplug CONTROL BOX (1) by carefully pulling it back and then up.
- C) Remove the AIR TUBE COVER PLATE (5) by loosening the retaining SCREW (4) (Two SCREWS – Model F5).
- D) Loosen SCREW (2), and then slide the complete drawer assembly out of the combustion head as shown.

Insertion:

- E) To insert drawer assembly, reverse the procedure in items A to D above.

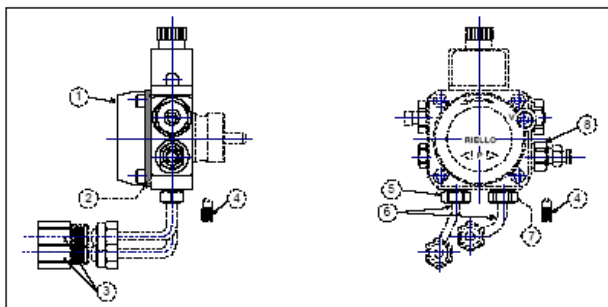


**Oil Line Connections**

This burner is shipped with the oil pump set to operate on a **single** line system. To operate on a **two-line** system the bypass plug must be installed.

**WARNING: Do not** operate a **single** line system with the by-pass plug installed. Operating a **single** line system with the by-pass plug installed will result in damage to the pump shaft seal.

**NOTE:** Pump pressure must be set at time of burner start-up. A pressure gauge is attached to the **PRESSURE PORT** (8) for pressure readings. Two **PIPE CONNECTORS** (6) are supplied with the burner for connection to either a single or two-line system. Also supplied are two **ADAPTORS** (3), two female 1/4" NPT, to adapt oil lines to burner pipe connectors. All pump port threads are **British Parallel Thread** design. Direct connection of NPT threads to the pump **will damage** the pump body. Riello manometers and vacuum gauges **do not** require any adapters, and can be safely connected to the pump ports. An NPT (metric) adapter **must** be used when connecting other gauge models.

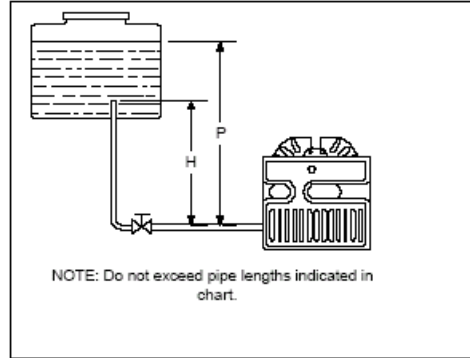


**Single Line (Gravity Feed)**

- A) The burner is shipped configured for use in single line applications. No changes to the oil pump are required for use in single line applications.

**NOTE:** If the **pump cover** (1) is removed for any reason, be sure the O-ring (2), is properly seated in the pump cover (1) before re-attaching the pump cover to the pump housing.

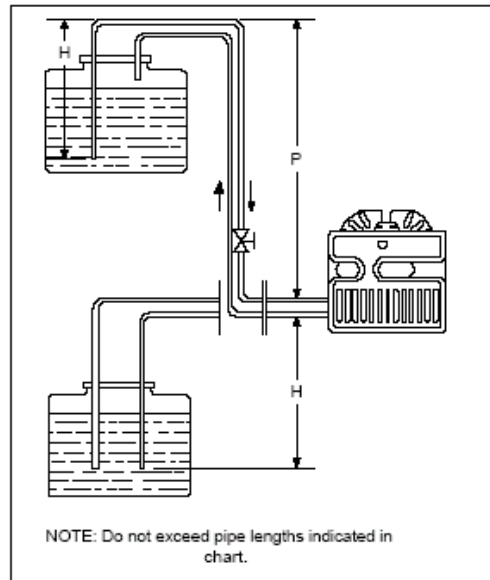
SINGLE LINE SYSTEM-PIPE LENGTHS					
H		3/8" OD		1/2" OD	
FT	M	FT	M	FT	M
1.5	0.5	33	10	65	20
3.0	1.0	65	20	130	40
5.0	1.5	130	40	260	80
6.5	2.0	195	60	325	100



- B) Connect the pipe connector to the SUPPLY PORT(5) of the pump. Attach the NPT adapter to the pipe connector. Attach the required piping to this pipe adapter. Be sure that the plug in the RETURN PORT (7) is tightened securely.

### Two Line (Lift System)

2 LINE (LIFT) SYSTEM-PIPE LENGTHS					
H		3/8" OD		1/2" OD	
FT	M	FT	M	FT	M
0.0	0.0	115	35	330	100
1.5	0.5	100	30	330	100
3.0	1.0	80	25	330	100
5.0	1.5	65	30	295	90
6.5	2.0	50	15	230	70
9.5	3.0	25	8	100	30
11	3.5	20	6	65	20



- A) If a two-line system is required, install the By-pass plug provided. The by-pass plug is installed in the return port of the pump. A 2.5-mm hexagonal key provided with the by-pass plug is to be used to install the plug. DO NOT use an inch size hexagonal key; damage to the by-pass plug may result. When operating on a two-line system, supply and return lines should be the same diameter and both **should extend to the same depth inside the fuel tank**. Be sure there are no air leaks or blockages in the piping system. Any obstructions in the return line will cause failure of the pump shaft seal.

To install the by-pass plug:

- 1) Remove the return plug (7)
  - 2) Install the by-pass plug (4) using the 2.5 mm hexagonal key
- B) Attach the two PIPE CONNECTORS (6) to the pump SUPPLY and pump RETURN PORTS (5 and 7). Attach the required piping to these two pipe connectors using the NPT/ METRIC ADAPTERS that are supplied with the burner.

**WARNING:** Pipe dope or Teflon tapes are NOT to be used on any direct oil connection to the fuel pump.

**WARNING:** The height 'P' in Pipe Length Charts should not exceed 13 feet (4 m).

**WARNING:** The vacuum should not exceed 11.44 inches of mercury.

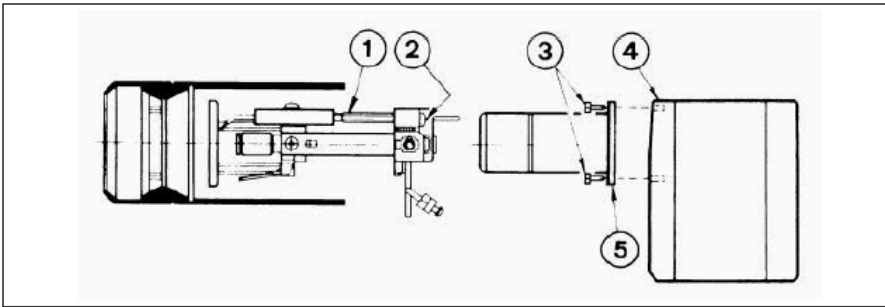
**IMPORTANT:** An external, appropriately listed and certified oil filter must be placed in the fuel line between the fuel tank and the burner pump.

### Assembly of Air Tube to Burner Chassis

The air tube and drawer assembly are shipped in a carton separate from the burner chassis. Choose the proper air tube length to obtain the tube insertion for the specific installation.

- Remove the AIR TUBE and BURNER CHASSIS from their respective cartons.
- Remove the DRAWER ASSEMBLY (1) from inside the AIR TUBE by loosening the screw (2). Carefully pull the DRAWER ASSEMBLY out of the AIR TUBE, install the required nozzle (see page 8) and set aside.

- C) Remove the two BOLTS (3) from FRONT PLATE (4) of the BURNER CHASSIS. Align the two holes on the AIR TUBE HOLDING PATE (5) with the two holes on the BURNER CHASSIS FRONT PLATE with the BOLTS (3) removed. Replace the BOLTS and fingers tighten only. Re-install DRAWER ASSEMBLY into AIR TUBE. Tighten SCREW (2) securely (see page 8).
- D) Tighten the two bolts (3) securely.

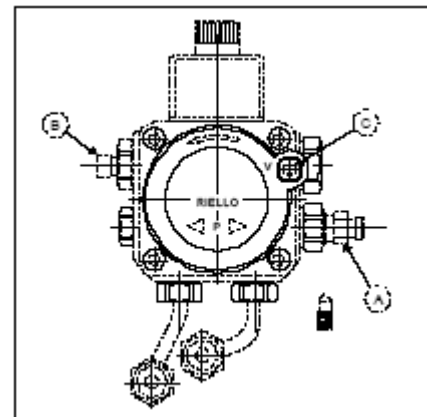


### Pump Purge

NOTE: To protect the pump gears, it is advisable to lubricate the pump prior to purging a lift system. Apply oil through the VACUUM PORT (C).

#### A) SINGLE LINE (GRAVITY FEED SYSTEM)

- I. Loosen the bleeder valve (A) until oil flows out. Tighten the bleeder valve securely and start burner.
- II. When bleeding the pump by pressure:
  - 1) Loosen the bleeder valve (A).
  - 2) Disconnect nozzle oil supply line at the pump nozzleport (B).
  - 3) Attach a flexible plastic tube to the pump nozzle, port directing the oil flow into a bucket.
  - 4) Loosen the screw(s) securing the air tube cover, allowing it to be removed freely.
  - 5) Holding the air tube cover in its proper location start the burner.
  - 6) When the solenoid valve is engaged approximately 10 seconds after starting, remove the air tube cover and shine a light source on the photocell, allowing it to see false light.
  - 7) Run the burner until the fuel pump has been purged of air, then tighten the bleeder valve and immediately shut down the burner.
  - 8) Reinstall the air tube cover and nozzle line
  - 9) The burner can now be started normally.



**WARNING:** Omitting steps 2 and 3 will result in a collection of unburned oil in the combustion chamber creating a hazardous situation upon burner startup.

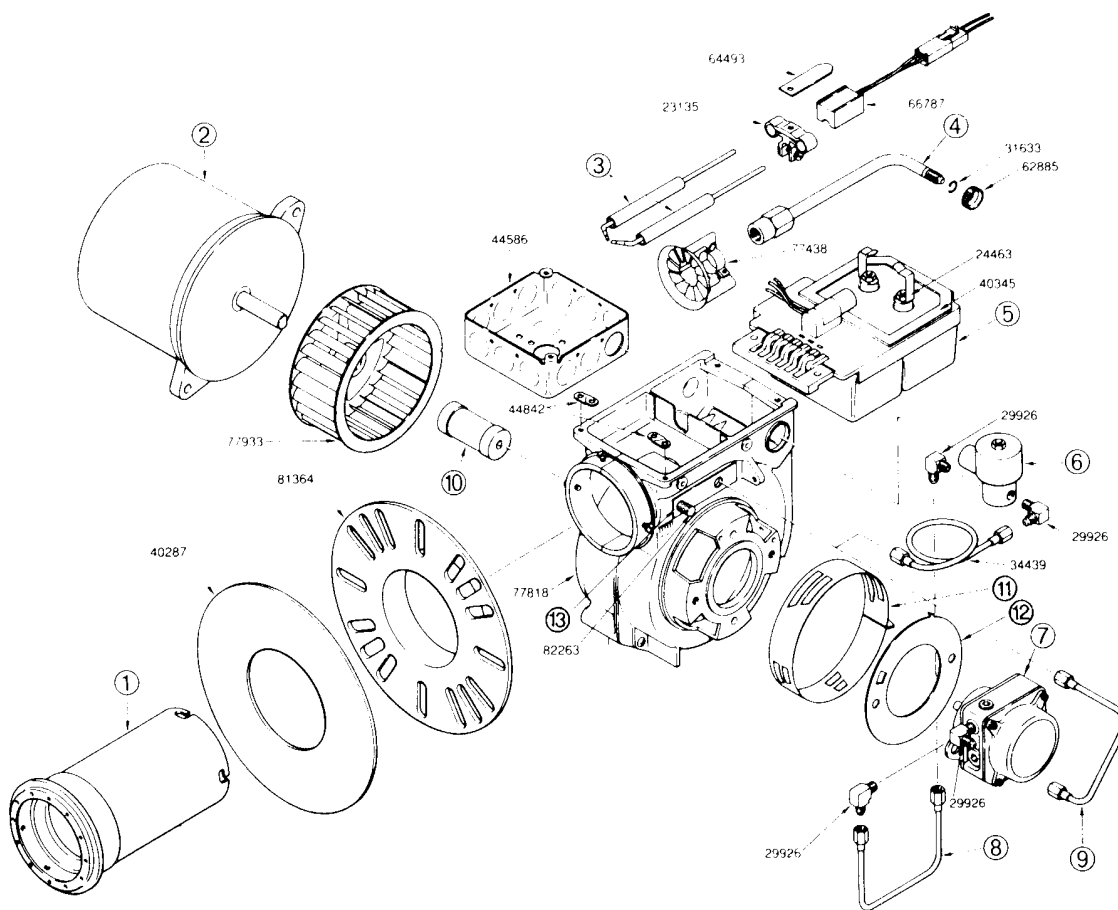
#### B) TWO LINE (LIFT SYSTEM)

Turn off the main power source to the burner and remove the air tube cover. Shines a light source on the photocell (now visible where the air tube cover was removed), return power to the burner and activate the burner. With the light source in place, the burner will operate in prepurge only. When the pump is sufficiently purged, the hydraulic air shutter will open. Once the burner is purged, turn off the power source and replace the air tube cover. Return power to the burner. The burner is now ready to operate.

**ATTENTION:** It is important that the fuel line be completely sealed and free from air leaks or any internal blockages.

**WARNING!** WHEN THE BYPASS PLUG IS INSTALLED, A TWO-PIPE SYSTEM MUST BE USED OR FAILURE OF THE PUMP SHAFT WILL OCCUR.

**FIG. 18-4A - CARLIN BURNER EXPLODED ASSEMBLY**



**FIG. 18-4B - CARLIN BURNER PARTS LIST**

ITEM NO.	PART NUMBER		QTY REQ'D		DESCRIPTION
	CARLIN	NEWMAC	EZ-1	EZ-1 PP	
1	77743		X	X	9" Air Tube c/w Welded Flange
2	98022		X	X	Motor, 1/6 hp, 3450 rpm
3			X	X	Electrode Wire, Set of 2
4			X	X	Nozzle Line / Adapter Assembly
5	41000SOCAS		X	X	14 kV Transformer / Ignitor
	40200-02		X		Primary Control, Interrupted Duty
	60200-02			X	Primary Control, Interrupted Duty, pre & post purge
6				X	Oil Valve ( in pump)
7	22996	2060004	X		Fuel Unit, Std. Single Stage, Suntec A2VA-7116
8	34397			X	Oil Line, 3/16 OD, Std. Fuel Unit to Oil Valve
9	34470		X		Oil Line, 3/16 OD, Std. Fuel Unit to Nozzle Line
10	75564		X	X	Coupling, For Std. Fuel Unit, Approx. 2-3/8" OAL
11	77594		X		Air Band
12	77586		X		Air Shutter
13	81570		X	X	Head Positioning Bar Kit
	4015300K		X	X	Flame Detector
	81695		X	X	CAD Cell Assembly c/w Harness
	77933		X	X	Blower Wheel
	40212		X	X	Flange Gasket
		2090063		X	Field Controls AirBoot (Field Controls p/n 4626802)

## IMPORTANT HOMEOWNER INSTRUCTIONS

1. AN EMERGENCY POWER SWITCH IS REQUIRED TO BE INSTALLED IN A CONVENIENT LOCATION AT A SAFE DISTANCE FROM THE BURNER. THIS SWITCH INTERRUPTS THE ELECTRICAL SUPPLY CIRCUIT TO THE APPLIANCE. MAKE SURE YOU ARE AWARE OF ITS LOCATION AND THE OFF POSITION IS CLEARLY MARKED.
2. KEEP THE SPACE CLEAR AROUND THE APPLIANCE WITHIN THE SPECIFIED CLEARANCES TO COMBUSTIBLES.
3. ENSURE THE SUPPLY OF COMBUSTION AIR TO THE APPLIANCE IS NOT OBSTRUCTED OR CUT-OFF.
4. MAINTAIN PROPER VENTILATION OF THE APPLIANCE AREA.
5. MAINTAIN FREE AIR FLOW THROUGH THE RETURN AIR REGISTERS. \*
6. CONTACT SERVICE PERSONNEL BEFORE REMODELLING.
7. CONTACT SERVICE PERSONNEL FOR ANNUAL SERVICE AND MAINTENANCE.
8. CONTACT SERVICE PERSONNEL FOR AIR FILTER REPLACEMENT. \*
9. CONTACT SERVICE PERSONNEL BEFORE AND AFTER EXTENDED PERIODS OF APPLIANCE INOPERATION.
10. THE BURNER IS FULLY AUTOMATIC IN OPERATION. ALL ADJUSTMENTS SHOULD BE MADE BY A QUALIFIED TECHNICIAN. DO NOT PUSH THE RESET BUTTON MORE THAN ONCE.

CAUTION : DO NOT ATTEMPT TO START THE BURNER WHEN EXCESS OIL HAS ACCUMULATED, WHEN THE APPLIANCE IS FULL OF VAPOUR, OR WHEN THE COMBUSTION CHAMBER IS VERY HOT.

11. **CAUTION : DO NOT TAMPER WITH THE APPLIANCE OR CONTROLS—CALL YOUR SERVICE PERSONNEL.**
12. **DO NOT USE GASOLINE, CRANKCASE OIL, OR ANY OIL CONTAINING GASOLINE**
13. ALWAYS KEEP THE OIL SUPPLY VALVE SHUT OFF IF THE BURNER IS SHUT DOWN FOR AN EXTENDED PERIOD OF TIME.
14. DO NOT START THE BURNER UNLESS THE BLOWER ACCESS DOOR IS SECURED IN PLACE.
15. NEVER BURN GARBAGE OR PAPER IN THE HEATING SYSTEM, AND NEVER LEAVE PAPER OR RAGS AROUND THE APPLIANCE.

\* FURNACES ONLY

## INSTALLER INFORMATION

**NAME :** \_\_\_\_\_ **COMPANY** \_\_\_\_\_

The homeowner should telephone (\_\_\_\_\_) \_\_\_\_\_ for a service call or for additional information.

### APPLIANCE INITIAL TEST AND SERVICE INFORMATION

**MODEL :** \_\_\_\_\_ **INSTALLATION DATE :** \_\_\_\_\_

		DATE	
1	FUEL INPUT (GPH)		
2	FUEL PRESSURE (PSIG)		
3	DRAFT @ BREECH		
4	DRAFT @ OVERFIRE		
5	NOZZLE ANGLE/PATTERN		
6	CO <sub>2</sub> PERCENT		
7	BURNER MODEL		
8	FLUE GAS TEMP °F		
9	ROOM TEMP °F		
10	SMOKE DENSITY N°.		
11	FUEL GRADE N°.		
12	STATIC PRESSURE IN WC (BONNET)		
13	AIR TEMP. INLET °F		
14	AIR TEMP. OUTLET °F		
15	AIR TEMP RISE °F		
16	LIMIT CONTROLS FUNCTIONING PROPERLY		
17	PRIMARY CONTROL		
A	SHUT OFF TIME (FLAME FAILURE)		
B	SHUT OFF TIME (IGNITION FAILURE)		
18	PULLEY TURNS OPEN		

**OIL FIRED FURNACE - LIMITED LIFETIME WARRANTY**

Effective July 1, 1995 and subject to the following conditions Newmac Manufacturing Inc. warrants the Oil Fired Furnace, to the original owner purchaser, under normal use and repair against defects in workmanship and materials for a period of one calendar year from the date of original installation. This warranty does not cover nozzles, filters, belts etc.

The burner, blower, motors, controls or any other electrical or mechanical components not manufactured by Newmac are warranted for a period of one year from date of original installation by their respective manufacturers; burners 3-5 years.

Effective July 1, 1995 and on the date of original installation Newmac warrants to the original purchaser during his or her lifetime that the primary heat exchanger of all Oil Fired Furnaces will be free from defects in material and workmanship provided however, this warranty shall apply only to the original installation of the furnace in a single dwelling unit used without interruption by the purchaser as his or her principal residence. This warranty does not apply to solid fuel or combination furnaces and is subject to the conditions and exceptions of warranty listed below.

Under the above warranty Newmac Mfg. at its option will repair or replace the heat exchanger under the above terms or offer the then current applicable retail price of a heat exchanger towards a new equivalent furnace. Proof of original purchase will be required.

The warranty must be registered within 30 days of installation or the following pro-rated warranty "Twenty Year Warranty" applies.

Where the owner of the dwelling is not the original purchaser and in multi-family dwellings Newmac warrants the primary heat exchanger against defects in materials and workmanship under a 20 year Limited Warranty subject to the conditions and exceptions listed below and on a prorated basis as follows of the then current retail price

	<u>Years</u>	100%	<u>Warranty</u>	0	<u>of Retail Price</u>
	0-10				
	11-12	"	"	50%	"
	12-14	"	"	60%	"
	14-16	"	"	70%	"
	16-18	"	"	80%	"
	18-20	"	"	90%	"
	20 years and over			100%	"

The purchaser must pay all other costs of warranty service including labour costs involving diagnostic calls and or removing, servicing and or replacing warranty parts and or warehousing charges and or freight costs. All parts are supplied F.O.B. Debert, Nova Scotia and the defective parts must be returned freight prepaid for repair and or warranty consideration when requested by Newmac Mfg.

**CONDITIONS**

This warranty refers to the primary combustion heat exchanger.

In order for this warranty to be effective:

1. The furnace must be installed by a qualified licensed installer and in accordance with Newmac's installation instructions. The furnace must also be installed in accordance with all applicable, local states, or provincial codes and the National Warm Air Heating and Air Conditioning Association Standards or generally accepted equivalent standards.
2. The Furnace must operate in an environment not contaminated by halogens (such as but not limited to fluorine or chlorine) or chlorinated hydro carbons. These corrosive chemicals entering the combustion area cause rapid deterioration of inner surfaces leading to heat exchanger failures. The furnace must be maintained and cleaned on an annual basis by qualified personnel; air filters should be changed monthly. Oil filters and nozzles must be changed annually.
3. The furnace must be sized and fired correctly as stated on the label for the residence. The label must not have been defaced or removed.
4. The furnace must not be modified from its published design or purpose and or an air conditioning coil shall not be installed on the return air side of the furnace.
5. Furnace must not have been removed from the original installation site.
6. There must be adequate return air and or ductwork.
7. There must be adequate combustion air installed to the furnace room; and in the case of sidewall venting there must be adequate ventilation air in addition to combustion air to prevent depressurization of the home.
8. Warranty components may be replaced with reconditioned parts at the discretion of Newmac Mfg.
9. Proof of original purchase will be requested under this warranty.

**EXCEPTIONS**

1. All labour, freight or diagnostic calls, removal and replacement costs and warehousing charges are the responsibility of the purchaser including the return to Debert, Nova Scotia of defective parts.
2. Defects or damages caused by failure of the refractory chamber, improper installation, wiring, electrical current characteristics, accident, misuse or abuse, fire, flood, alteration and or misapplication of the product, default or delay in performance; caused by war, government restrictions, restraints, strikes, material or freezing.
3. Refractory chamber, nozzles, air filters, belts etc...
4. Defects or damages caused by nozzle failure and/or plugging and/or oil flow restrictions due to cold oil from outside tanks or misalignment of burner at installation.
5. This warranty in no way can be considered as a guarantee of workmanship of an installer connected with the installation of the Newmac Oil Fired Furnace or as imposing on Newmac any liability of any nature for unsatisfactory performance as a result of faulty workmanship in the installation which liability is expressly disclaimed.
6. This warranty will not be applicable if the furnace is damaged or a result of being improperly serviced or operated.

**LIMITATIONS ON WARRANTY**

Newmac will make no express warranties other than the warranty set forth above. All implied warranties including the implied warranties of a merchantability and fitness for a particular purpose are limited to the duration of the express warranty, set forth above. Liabilities for incidental and consequential damages are excluded regardless of the cause. Some provinces in Canada and some states in the U.S.A. do not allow limitations on how long an implied warranty lasts so the above may not apply to you. The expressed warranties made in this warranty are exclusive and may not be altered, enlarged or changed by any distributor, dealer or any other person whatsoever. All replacement parts whether new or remanufactured, assume as their warranty period on the remaining period of this warranty.

For routine service requirements contact the dealer who installed the equipment originally, or an alternate qualified and registered heating dealer or electrical.

To register your warranty, please complete form below, detach and mail to Newmac Mfg. Inc. P.O. Box 9, Lancaster Cr; Debert, N.S. B0M 1G0

LIMITED LIFETIME WARRANTY REGISTRATION

-----  
 Owner's Name Date of Installation

-----  
 Address of Installation

-----  
 Dealer's Name Dealer's Address

-----  
 Furnace Serial Number Furnace Model Number