

MEDIA AIR CLEANER

Models: FC8-1400, FC11-1400, FC11-1600, FC8-2000, FC11-2000, FCRA-2000



ITEMS INCLUDED IN KIT:

- 1- Cabinet
- 1- Media Filter
- 1- Installation Instruction Manual
- 1- Foam Gasket material (FCRA-2000 only)

GENERAL SYSTEM INFORMATION

Field Controls high efficiency series of media air cleaners are designed for installation into heating, ventilation, air conditioning (HVAC) systems to reduce the amount of airborne particulate (1.0 micron and larger) including pollen, dust and dander promoting better indoor air quality. The media air cleaner should be installed in the return air system duct, such that all of the circulated air passes through the filter. For maximum filtering performance, the air circulation fan should operate continuously.

Model	FC8 - 1400	FC11 - 1400	FC11 - 1600	FC8 - 2000	FC11 - 2000	FCRA - 2000
Nominal filter size	16" x 25" x 5"	16" x 25" x 5"	20" x 20" x 5"	20" x 25" x 5"	20" x 25" x 5"	20" x 25" x 5"
Air flow range	600-1400 CFM	600-1400 CFM	600-1600 CFM	600-2000 CFM	600-2000 CFM	600-2000 CFM
MERV rating	8	11	11	8	11	11
Filter Repl. P/N	46585900	46568500	46607000	46586000	46568600	46568600
Cabinet size	16- ¹ / ₄ x 24- ⁷ / ₈ x 7- ¹ / ₈	16- ¹ / ₄ x 24- ⁷ / ₈ x 7- ¹ / ₈	20- ¹ / ₄ x 21- ³ / ₈ x 7- ¹ / ₈	20- ¹ / ₄ x 24- ⁷ / ₈ x 7- ¹ / ₈	20- ¹ / ₄ x 24- ⁷ / ₈ x 7- ¹ / ₈	23- ³ / ₈ x 25- ⁵ / ₈ x 15- ¹ / ₂
Cabinet open.	13- ⁷ / ₈ " x 22- ¹ / ₂ "	13- ⁷ / ₈ " x 22- ¹ / ₂ "	17- ⁷ / ₈ " x 19"	17- ⁷ / ₈ " x 22- ¹ / ₂ "	17- ⁷ / ₈ " x 22- ¹ / ₂ "	13- ³ / ₈ " x 23"
Media UL listing	Class 2	Class 2	Class 2	Class 2	Class 2	Class 2

NOTE: FOR OPTIMUM PERFORMANCE, REPLACE THE MEDIA FILTER EVERY 6 TO 12 MONTHS.

READ THESE INSTRUCTIONS CAREFULLY AND COMPLETELY BEFORE PROCEEDING WITH THE INSTALLATION.

This device **MUST** be installed by a qualified agency in accordance with the manufacturer's installation instructions. The definition of a qualified agency is: any individual, firm, corporation or company which either in person or through a representative is engaged in, and is responsible for, the installation and operation of HVAC appliances, who is experienced in such work, familiar with all the precautions required, and has complied with all the requirements of the authority having jurisdiction.

Please retain these instructions after installation.

Installed By: _____ Phone: _____ Installation Date: _____



FIELD CONTROLS

www.fieldcontrols.com

MOUNTING OPTIONS

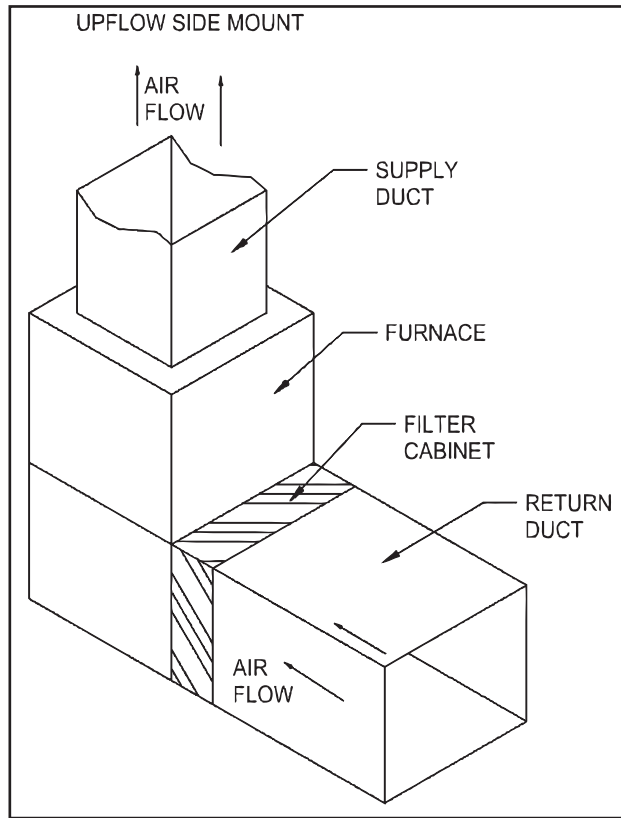

Figure 1

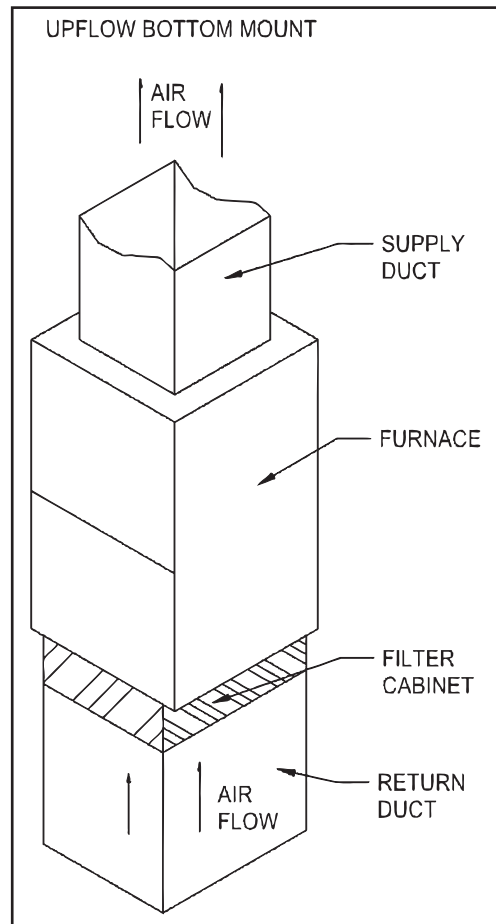

Figure 2

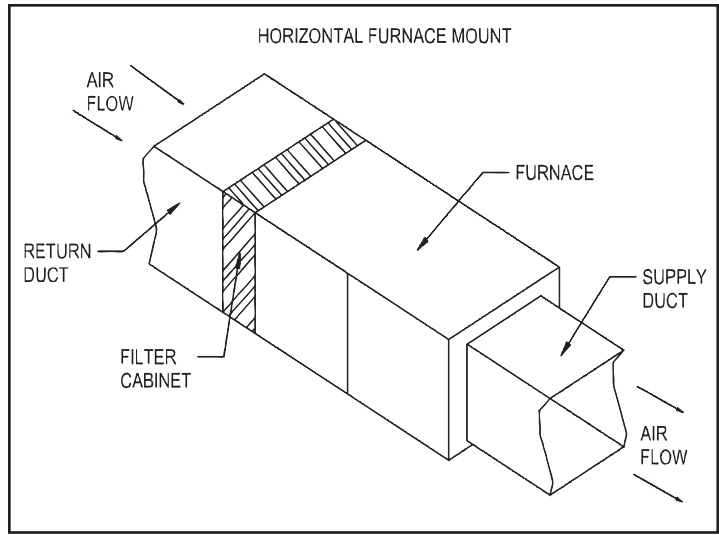

Figure 3

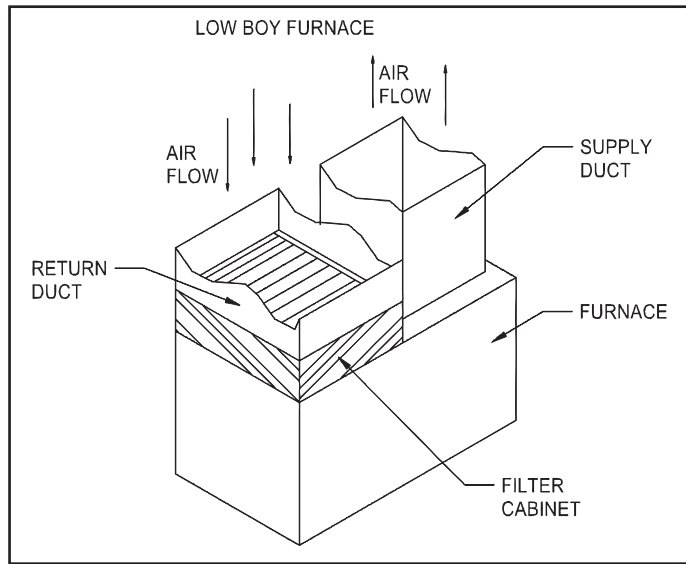

Figure 4

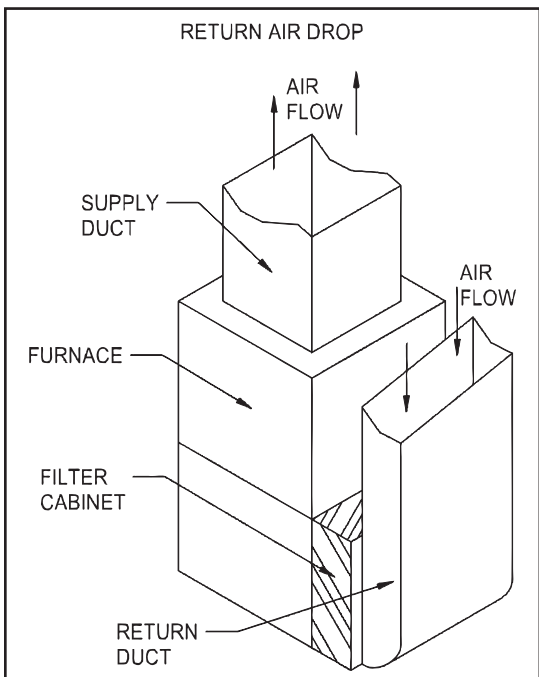

Figure 5

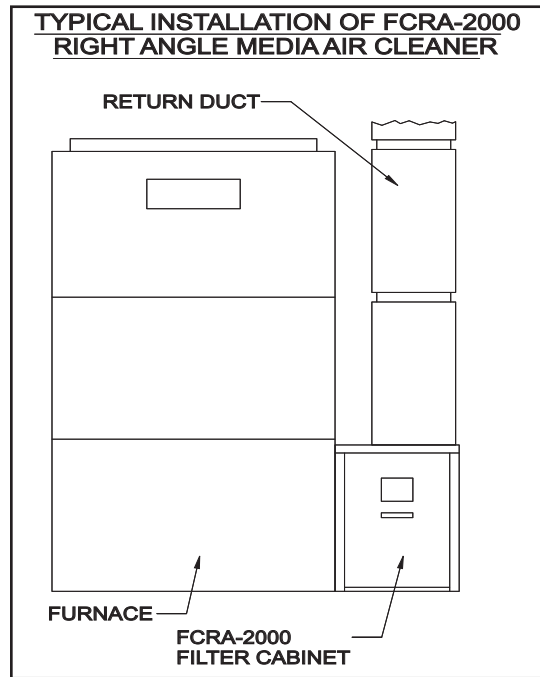

Figure 6

CAUTION

Before installing a media filter into the HVAC system, the Qualified Agency must consider the additional pressure drop being added to the HVAC system.

1. The filter must be installed on the return side of the HVAC system, between the return air duct and the intake of the system blower. **NEVER** install on the supply side of the HVAC system.
2. The filter access panel **MUST** be installed where there is at least 26" in front of it. This allows clearance for the replacement of the media filter.
3. Systems with UV lights: **DO NOT** expose the media filter directly to UV lights. Degradation of the filter material can occur.
4. Some installations may require a duct transition. Transitions may be needed to reduce pressure drop and maintain appliance efficiency. The appliance must operate within the manufacturer's recommended temperature and pressure drop requirements.
5. Check the flow capacity and pressure drop (Figure 7) to determine the filter is properly sized.

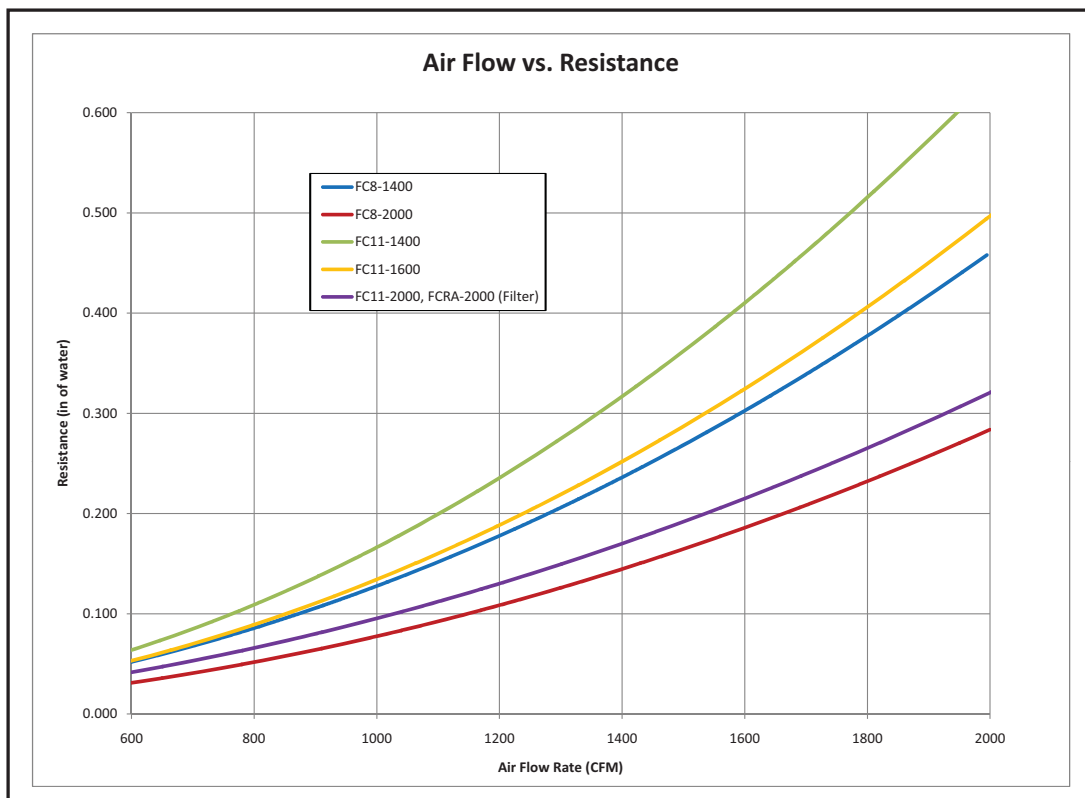

Figure 7

INSTALLATION



WARNING: Always shut off the electrical power supply before working on the appliance.

1. Refer to the typical mounting positions (Figures 1 to 6) for proper placement of the filter cabinet.
2. Remove the metal filter cabinet from the carton and plastic bag.
3. Remove the access panel door and pull the media filter (in plastic bag) out of the cabinet. DO NOT install the media filter with the plastic bag around it.
4. Position cabinet so access panel is available for easy media filter replacement. The access panel MUST be accessible to remove and replace the media filter. (**NOTE:** Minimum of twenty-six (26) inches for front clearance).
5. Position the filter cabinet onto return air side of the appliance (Figures 1 to 6). Duct transitions may be required to properly mount the filter cabinet. (**NOTE:** The FCRA-2000 is reversible and may be installed on either side of the appliance).
6. When the filter cabinet is mounted directly to the appliance or existing duct, mark the inside opening of the filter cabinet and all 12 mounting screw locations.
7. Drill the marked mounting holes with a 1/8" diameter drill bit. Remove the marked filter opening with metal cutting shears or equivalent.
8. Apply included foam gasket material to perimeter of appliance opening (FCRA-2000 only).
9. FCRA-2000 only: Install the access panel door without a handle on the rear opening of the cabinet, if necessary, adjust the inlet opening collar to the desired position (either 24" x 8" or 24" x 10") and reinstall securing screws.
10. Attach filter cabinet to the appliance or duct work using #8 X 1/2" long sheet metal screws or pop rivets. Seal the housing and/or duct connections with aluminum duct tape or equivalent.
11. Remove media filter from the plastic bag and discard the plastic bag. **TIP:** Write the installation date on filter next to directional arrow for future filter replacement reference. The media filter MUST be installed WITHOUT the plastic bag.
12. Install media filter into the filter cabinet. Insure the air flow direction arrow points downstream, in the direction of the appliance.
13. Install the filter cabinet access panel.
14. Place appliance back into service. Appliance must operate within the appliance manufacturer's recommended temperature and pressure drop requirements.

MAINTENANCE

The media filter **MUST** be replaced periodically. The reason is to maintain appliance operating efficiency by minimizing pressure drop through the HVAC system. The frequency of filter media replacement depends on the operational environment. The need for replacement is easily determined by a visual inspection. **NOTE:** For optimum performance, replace the media filter every 6 to 12 months.

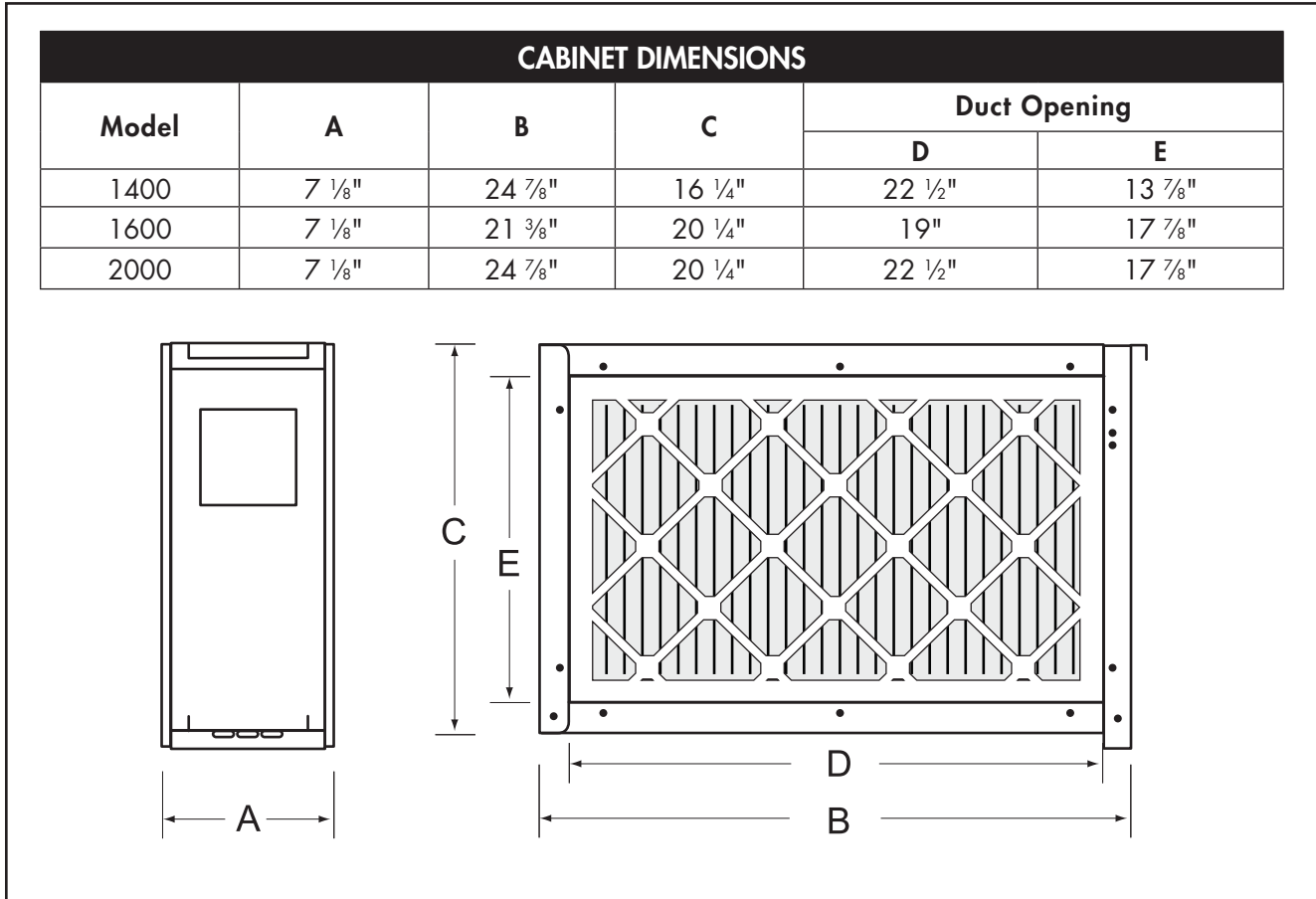

Figure 8

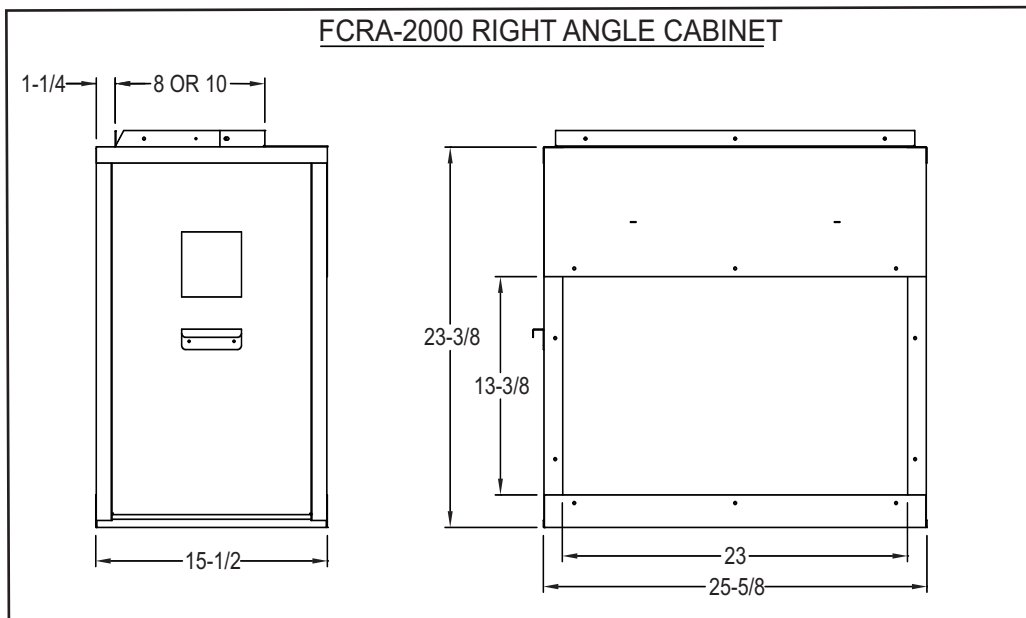

Figure 9

MEDIA FILTER REPLACEMENT PROCEDURE

1. Turn off electrical power to the HVAC system.
2. Remove the filter cabinet access panel. **NOTE:** "AIR FLOW" directional arrow, located on existing media filter (Figure 8 and 9).
3. Remove the existing filter media.
4. Remove the new media filter from the plastic bag. **TIP:** Re-use plastic bag to discard the used media filter.
5. Check media filter directional arrow (→)! The directional arrow **MUST** point in the direction of air flow.
TIP: Write the installation date on media filter next to directional arrow for future filter replacement reference.
6. Install the new media filter.
7. Install the filter cabinet access panel.
8. Turn on electrical power to the HVAC system.

REPLACEMENT PARTS LIST

AIR CLEANER MODEL	REPLACEMENT FILTER SIZE	REPLACEMENT FILTER PART NUMBER	NUMBER OF FILTERS PER CARTON
FC8 - 1400	16" x 25" x 5"	46585900	3
FC8 - 2000	20" x 25" x 5"	46586000	3
FC11 - 1400	16" x 25" x 5"	46568500	3
		46600401 (Flex-2)	6
FC11 - 1600	20" x 20" x 5"	46607000	3
		46600407 (Flex-1)	6
FC11 - 2000 FCRA - 2000	20" x 25" x 5"	46568600	3
		46600401 (Flex-2)	6

LIMITED WARRANTY

Field Controls, LLC ("Company") warrants that its products shall be free from defects in material and workmanship under normal use for the limited period indicated, **from the date of manufacture, subject to the provisions 1-8 below.**

Eighteen (18) months

All Field Controls Products (except for those listed below as 5 years or 90 days).

Five (5) years

Field Controls Direct Vent Systems (FDVS), Field Oil Vent Kits (FOVP), and ComboVents (CV).

Field Controls warrants that the products listed below shall be free from defects in material and workmanship under normal use for the limited period indicated, **from the date of purchase by the consumer, subject to the provisions 1-8 below.**

Ninety (90) days

UV lamps/bulbs

Provisions:

1. During the limited warranty period, Company, or its authorized service representative, will repair or replace, at Company's option, without charge, a defective Product. Product that is repaired may be repaired with new or refurbished replacement parts. Product that is replaced may be replaced with a new or refurbished product of the same or similar design. Company will return repaired or replacement Product to customer in working condition. Labor charges are not covered as part of the limited warranty.
2. With regard to UV lamps/bulbs, customer shall be required to include a "valid proof of purchase" (sales receipt) identifying the Product purchased (Product model or accurate date code information) and the date the Product(s) was purchased.
3. Product whose warranty/quality stickers, Product serial number plates or electronic serial numbers have been removed, altered or rendered illegible shall not be covered under the limited warranty.
4. Defective Product must be returned to Company, postage prepaid.
5. IN NO EVENT SHALL COMPANY BE LIABLE FOR ANY INDIRECT, SPECIAL, INCIDENTAL, CONSEQUENTIAL, OR SIMILAR DAMAGES (INCLUDING, BUT NOT LIMITED TO, LOST PROFITS OR REVENUE, INABILITY TO USE PRODUCT, OR OTHER ASSOCIATED EQUIPMENT, THE COST OF SUBSTITUTE EQUIPMENT, AND CLAIMS BY THIRD PARTIES) RESULTING FROM THE USE OF PRODUCT. Some states do not allow the exclusion or limitation of incidental or consequential damages, so the above limitation or exclusion may not apply to you.
6. THIS WARRANTY AND REMEDIES ARE EXCLUSIVE AND IN LIEU OF ALL OTHER WARRANTIES, REMEDIES AND CONDITIONS, WHETHER ORAL, WRITTEN, EXPRESS, STATUTORY OR IMPLIED. TO THE EXTENT PERMITTED BY LAW, COMPANY DISCLAIMS ALL IMPLIED AND STATUTORY WARRANTIES, INCLUDING WARRANTIES OF MERCHANTABILITY AND FITNESS FOR A PARTICULAR PURPOSE.
7. Company makes no warranty of any kind in regard to other manufacturer's products distributed by Company. Company will pass on all warranties made by the manufacturer and where possible, will expedite the claim on behalf of the customer, but ultimately, responsibility for disposition of the warranty claim lies with the manufacturer.
8. Product that has been subjected to misuse, accident, shipping or other physical damage, improper installation or application, abnormal operation or handling, neglect, fire, water or other liquid intrusion are not covered by the warranty.



FIELD CONTROLS

Phone: 252.522.3031 • Fax: 252.522.0214

www.fieldcontrols.com